

TRICITY BENDIX

*OPERATING & INSTALLATION
INSTRUCTIONS*



REFRIGERATOR

TB 584 R

**This instruction book contains safety precautions, information on use and helpful hints and tips.
To ensure you use this appliance effectively and safely, please read this instruction book carefully
before installing or using this appliance and retain for future reference.**

The symbols below help you to find things more easily:



Safety precautions

Warnings and Safety information



Hints, useful information



Environmental information

IMPORTANT SAFETY INSTRUCTIONS

These warnings are provided in the interests of your safety. Ensure that you understand them all before installing or using this appliance. Your safety is of paramount importance. If you are unsure about any of the meanings or these warnings contact the Customer Care Department.

Prior to installation

- Check the appliance for transport damage. Under no circumstances should a damaged appliance be installed. In the event of damage please contact your retailer.

Installation

- This appliance is heavy. Care should be taken when moving it.
- It is dangerous to alter the specifications or attempt to modify this product in any way.
- Ensure that the appliance does not stand on the electrical supply cable. If the supply cable is damaged, it must be replaced by a cable available from your local Service Force Centre.
- Any electrical work required to install this appliance should be carried out by a qualified electrician or competent person.
- Parts which heat up should not be exposed. Whenever possible, the back of the appliance should be close to a wall, but leaving the required distance for ventilation, as stated in the installation instructions.
- The appliance should be left for 2 hours after installation before it is turned on, in order to allow the refrigerant to settle.

Child Safety

- Do not allow children to tamper with the controls or play with the product.
- There is a risk of suffocation! Keep packaging material away from children!

During Use

- This appliance is designed for domestic use only, specifically for the storage of edible foodstuffs. It is not intended for commercial or industrial use.
- Containers with flammable gases or liquids can leak at low temperatures. Do not store any containers with flammable materials, such as spray cans, fire extinguisher refill cartridges etc.
- Frozen food should not be refrozen once it has thawed out.
- Do not place carbonated or fizzy drinks in the freezer compartment.
- Ice lollies can cause 'frost/freezer burns' if consumed straight from the freezer compartment.

- Do not remove items from the freezer compartment if your hands are damp/wet, as this could cause skin abrasions or frost/freezer burns.
- Bottles and cans must not be placed in the freezer compartment they can burst when the contents freeze.
- Manufacturers' recommended storage times should be adhered to. Refer to relevant instructions.

Maintenance and Cleaning

- Before cleaning, always switch off the appliance and disconnect from the electrical supply.
- When unplugging always pull the plug from the mains socket, do not pull on the cable.

Servicing

- This product should be serviced by an authorised engineer and only genuine spare parts should be used.
- Under no circumstances should you attempt to repair the appliance yourself. Repairs carried out by inexperienced persons may cause injury or serious malfunctioning. Contact your local Service Force Centre.

At the end of the Appliance Life

- When disposing of your appliance use an authorised disposal site.
- Remove the plug and ensure that any locks or catches are removed, to prevent young children being trapped inside.



The Appliance and the Environment

This appliance does not contain gasses which could damage the ozone layer.

Avoid damaging the cooling unit.

The packaging used on this appliance marked with the  symbol is recyclable.

Keep this instruction book for future reference and ensure it is passed on to any new owner.

CONTENTS

Instructions for the User

Guide to use the Instruction Book	2
Important Safety Instructions	3
Instructions for the User	5
General Information	5
Description of the Appliance, main parts	5
Using the Appliance	6
Before Use	6
To Start the Appliance	6
Thermostat Control	6
Hints for storage	6
Hints and Tips	7
Food Storage	7
Energy Saving Advice	7
Thawing	8
To make ice cubes	8
Storage Shelves	8
Maintenance and Cleaning	8
Internal cleaning	8
When the appliance is not in use	8
External cleaning	8
Defrosting	8
Changing the Light Bulb	9
Storage Chart (1)	10
Storage Chart (2)	10
Something Not Working	11
Guarantee Conditions	12

Instructions for the Installer

Technical Data	15
Installing the Appliance	15
Transportation, Unpacking	15
Cleaning	15
Location	15
Levelling	16
Ventilation Requirements	16
Door Reversal	17
Electrical Connection	19

INSTRUCTIONS FOR THE USER

General information

This appliance is designed for the refrigeration of food in a domestic home. It has a four-star frozen food compartment for ice making, frozen food storage and freezing fresh food.

To ensure correct operation, the appliance should be located where the ambient temperature is between 16-32 °C.

Description of the appliance, main parts

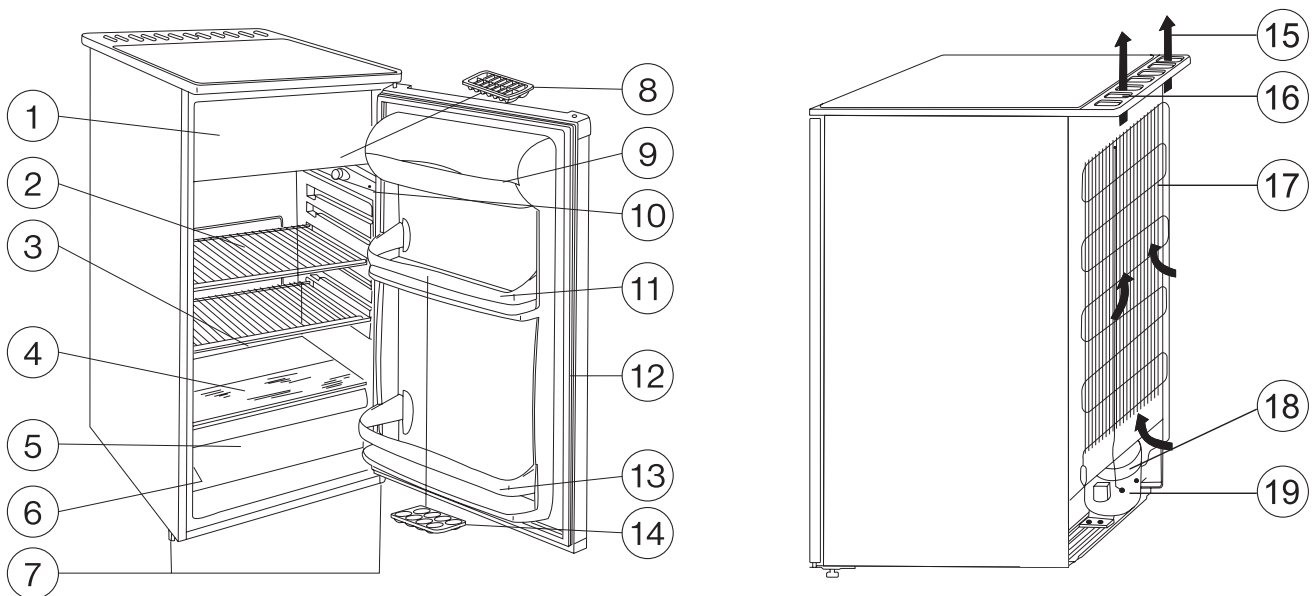

- | | |
|--|---------------------|
| 1. Frozen food compartment | 11. Door shelf |
| 2. Wire shelf | 12. Gasket |
| 3. Defrost water outlet | 13. Bottle shelf |
| 4. Glass shelf | 14. Egg tray |
| 5. Salad drawer | 15. Air circulation |
| 6. Rating plate | 16. Air Vent |
| 7. Adjustable feet | 17. Condenser |
| 8. Ice tray | 18. Evaporator tray |
| 9. Butter compartment | 19. Compressor |
| 10. Interior Light /Thermostat Control | |

Using the Appliance

Before Use

Remove all securing tapes.

Wash the inside of the appliance with lukewarm water with a little bicarbonate of soda added (5 ml to 0,5 litre of water). Do not use soap or detergent as the smell may linger. Dry the appliance thoroughly.

 **Do not use detergents, abrasive powders, highly perfumed cleaning products, wax polishes or products containing alcohol.**

To Start the Appliance

1. Allow the appliance to stand for 2 hrs after installation.
2. Plug in the appliance and switch on at the mains supply.
3. Turn the thermostat control to the required setting.
A setting of 3 is usually suitable for normal operation (see thermostat control).
4. Leave the appliance for approximately 4 hours for the correct temperature to be reached before placing food inside.

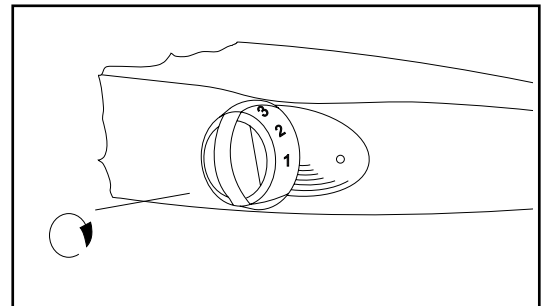

Thermostat Control

The thermostat control situated inside the refrigerator regulates the temperature of both compartments. Thermostat control is marked from 1-5 the higher the number, the colder the setting.

- Position „0” - Off
- Position 1 - Cold
- Position 5 - Coldest

With the control knob set at „3” the temperature inside the fresh food compartment is +5 °C or lower and the temperature inside the frozen food compartment is -18 °C or lower.

Hints for storage

Below is the recommended storage positions for various food types:

1. Storing frozen foods, making ice. Freezing fresh foods.
2. Confectionery, ready-cooked foods
3. Foods in dishes
4. Opened cans
5. Milk, dairy products
6. Fresh meat, cold cuts, sausages, etc.
7. Fruits, vegetables, salads
8. Cheese, butter
9. Eggs
10. Yoghurt, sour cream
11. Small bottles, soft drinks
12. Big bottles, drinks

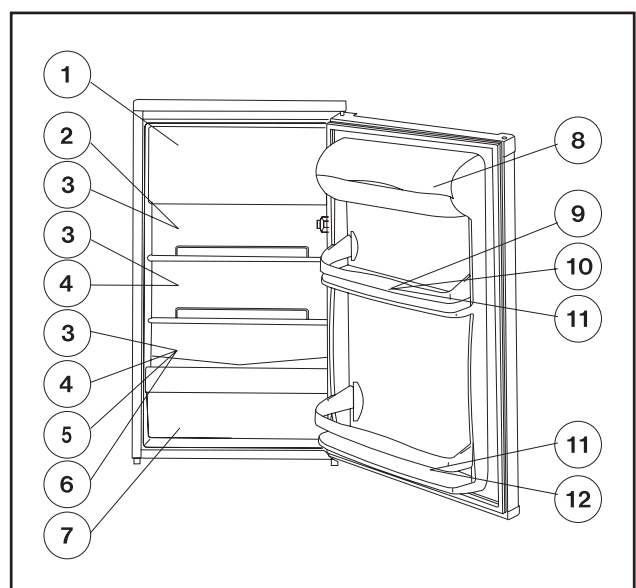

Hints & Tips

Normal Operating Sounds

- You may hear faint gurgling or bubbling sounds when the refrigerant is pumped through the coils or tubing.
- When the compressor is on, the refrigerant is being pumped round and you will hear a whirring sound or pulsating noise from the compressor.
- A thermostat controls the compressor and you will hear a faint 'click' when the thermostat cuts in and out.

Food Storage

To obtain the best performance from your appliance:

- Neither hot foods nor liquids which may evaporate, should be placed in the larder compartment.
- Keep the time between buying chilled food and placing it in your fridge as short as possible.
- Do not store warm food or evaporating liquid.
- Avoid buying frozen food if you cannot store it straight away. The use of an insulated container is advisable. When you arrive home, place the frozen food in the freezer immediately.
- Do not push food together too much, try to allow air to circulate around each item.
- Do not store food uncovered.
- Ensure that food placed in the freezer is dated and labelled and used in date order to ensure that food is consumed at its best.
- Lean food keeps better and longer than fatty food, salt reduces the storage time.
- Wrap the food in polythene or aluminium freezing bags or foil so that they adhere to the food and provide an airtight seal.
- Packaging which is swollen or has traces of refrozen water droplets on the pack could indicate that the product has not been kept at a suitable temperature and that it may have lost its original quality. Partially thawed food must not be refrozen, it must be consumed within 24 hours. Never exceed the storage times indicated by the manufacturer.

Energy Saving Advice

- Do not install the appliance close to sources of heat, such as a boiler or radiator.
- Locate the appliance in a cool well ventilated room and make sure that the air openings of the appliance are not obstructed.
- Avoid unnecessary frosting in the cabinet by packing all foodstuffs into airtight packages before placing them in the freezer.
- Food which is to be frozen (when cool) should be placed in the fridge before being transferred to the freezer.
- Try to avoid keeping the door open for long periods or opening the door too frequently as warm air will enter the cabinet and cause the compressor to switch on unnecessarily often.
- Ensure there are no obstructions preventing the door from closing properly.

In the Event of a Power Failure

If there is a power failure during the storage of frozen foods, keep the door closed. If the temperature within your freezer should rise, do not refreeze the food without checking its condition. The following guidelines should assist you:

Ice Cream: Once thawed should be discarded.

Fruits & Vegetables: If soft should be cooked and used up.

Breads & Cakes: Can be refrozen without danger.

Shellfish: Should be refrigerated and used up quickly.

Cooked Dishes: i.e. casseroles should be refrigerated and used up.

Large Pieces of Meat: Can be refrozen providing there are still ice crystals remaining within them.

Small Joints: Should be cooked and can then be refrozen as cooked dishes.

Chicken: Should also be cooked and refrozen as a fresh dish.

Thawing

Deep frozen or frozen food, prior to being used, can be thawed in the fridge or at room temperature, depending on the time available. Small food items may even be cooked from frozen, in this case cooking will take longer.

Any frozen food which is allowed to thaw accidentally should either be eaten as soon as possible, or thrown away. Alternatively, if the food is uncooked and has not been completely defrosted it can be cooked and then refrozen.



Defrosted cooked food must never be refrozen.



To Make Ice Cubes

1. Fill the ice cube tray $\frac{3}{4}$ full with cold water, place on the freezing compartment and leave to freeze.
2. To remove the cubes twist the tray or hold it under running water for a few seconds.



Never try to free an ice tray that is frozen to the freezer shelf by using pointed or sharp edged objects.

Storage Shelves

The shelves in the refrigerator compartment are adjustable to allow for the storage of large items.

The shelves can be re-arranged by opening the door to 90°

The door shelves are also adjustable.



To allow the air to circulate within the fridge compartment do not cover the wire shelves with paper or trays.

Do not remove items from the freezer if your hands are damp/wet, as this could cause skin abrasions or frost/freezer burns.

Maintenance and Cleaning



Before any maintenance or cleaning is carried out you must DISCONNECT the appliance from the electricity supply.

Internal Cleaning

Clean the inside and accessories with warm water and bicarbonate of soda (5 ml to 0.5 litre of water).

Rinse and dry thoroughly.



NEVER use detergents, abrasive powders, highly perfumed cleaning products or wax polishes to clean the interior as these will damage the surface and leave a strong odour.

External Cleaning

Wash the outer cabinet with warm soapy water.

Once or twice a year dust the condenser (black grille) and the compressor at the back of the appliance with a brush or vacuum cleaner, as an accumulation of dust will affect the performance of the appliance and cause excessive electricity consumption.

When the Appliance is not in Use

When the appliance is not in use for long periods, disconnect from the electricity supply, empty all of the food and clean the appliance, leaving the door ajar to prevent unpleasant smells.

Defrosting

Refrigerator

The refrigerator defrosts every time the compressor stops. The water is discharged, via the pipe, into a tray located at the back of the appliance above the compressor, where it evaporates.

Freezer

The freezer compartment will become progressively covered with frost. This should be removed with the special plastic scraper provided, whenever the thickness of the frost reaches $\frac{1}{4}$ ".

During this operation it is not necessary to switch of the power supply or to remove the foodstuffs.

However, when the ice becomes very thick on the inner liner, complete defrosting should be carried out and it is advisable to perform this operation when the appliance is empty.

For complete defrosting (once or twice a year) proceed as follows:

- 1 Turn the thermostat dial to the "OFF" position (O) or disconnect the appliance from the mains.
- 2 Remove any food from inside the freezer and fridge; wrap it in several sheets of newspaper and store in a cool, dry place.
- 3 When defrosting is complete, dry the interior thorough.
- 4 Reconnect the appliance to the mains or reset the thermostat to 5 (coldest) and leave to run for at least four hours.
- 5 Replace the previously removed food.
- 6 Return the thermostat to the normal position.

Important

A temperature rise of the frozen food packs during defrosting may shorten their safe storage life.

Never use sharp metal tools to scrape off frost from the evaporator as this could damage the appliance beyond repair.

Changing the Light Bulb

Should the light fail to work you can change it as below:

Disconnect the appliance from the electricity supply.

Remove the lamp cover retaining screws, then take the lamp cover off in the direction of arrow and the bulb can be changed. (Type of the bulb: 230 V, 15 W, E 14 thread)

After changing bulb replace the lamp cover and retaining screws and reconnect the appliance to the electricity supply.

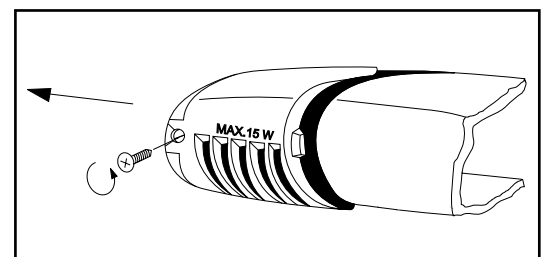
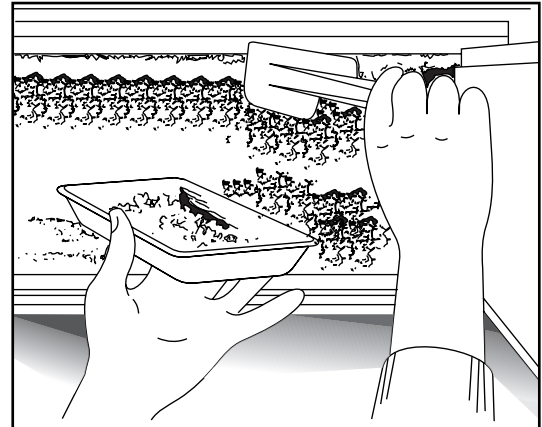

Storage time chart (1)

Time and method of storage of fresh foods in the refrigerator

Foods	Storage time in days							Method of packaging
	1	2	3	4	5	6	7	
Raw meat	X	X	x	x	x			cling film, airtight
Cooked meat	X	X	X	x	x	x		dish covered
Roasted meat	X	X	X	x	x			dish covered
Raw minced meat	X							dish covered
Cooked minced meat	X	X	x	x				dish covered
Cold cuts	X	X	x	x				cling film, cellophane, grease-proof paper
Fresh fish	X	x	x					cling film, airtight
Cooked fish	X	X	x	x				dish covered
Tinned fish, open	X	x	x					dish covered
Fresh chicken	X	X	X	x	x	x		cling film, airtight
Fried chicken	X	X	X	x	x	x		dish covered
Fresh duck, goose	X	X	X	x	x	x		cling film, airtight
Roasted duck, goose	X	X	X	X	x	x	x	dish covered
Butter unopened	X	X	X	X	X	X	X	original packaging
Butter opened	X	X	x	x	x	x	x	original packaging
Milk	X	X	X	x	x			original packaging
Cream	X	X	x	x				plastic box
Sour cream	X	X	X	X	x	x	x	plastic box
Cheese (hard)	X	X	X	X	X	X	X	aluminium foil
Cheese (soft)	X	X	X	X	x	x	x	cling film
Egg	X	X	X	X	X	X	X	
Spinach, sorrel	X	X	x	x				cling film
Green peas, green beans	X	X	X	X	x	x	x	cling film
Mushroom	X	X	x	x	x			cling film
Carrot	X	X	X	X	X	X	X	cling film
Tomato	X	X	X	X	X	X	X	cling film
Cabbage	X	X	X	X	X	x	x	cling film
Strawberry, raspberry, etc.	X	X	X	x	x			cling film
Tinned fruits opened	X	X	X	x	x			dish covered
Cakes filled with cream	X	X	x	x				dish covered

Notation:

- X recommended storage time
- x maximum recommended storage time

Storage time chart (2)

Storage time of deep-frozen and frozen products

Foods	In the fresh food compartment +2 - +7 °C	In the ****frozen food compartment -18 °C
Vegetables: green beans, green peas, mixed vegetables, marrow, corn, etc.	1 day	12 months
Ready-cooked foods: vegetable dish, trimmings, with meat, etc.	1 day	12 months
Ready-cooked foods: sirloin steaks, stews	1 day	6 months
Soups	1 day	6 months
Fruits: cherry, gooseberry, fruit cream	1 day	12 months
Meat: chicken, duck, goose, tuna fish	1 day	5 months
Ice-cream, Ice-lollies	1 day	3 weeks

Something Not Working

If the appliance is not working correctly, please carry out the following checks before contacting your local Tricity Bendix Service Force Centre.

Problem	Possible Cause	Solution
No power to the appliance	No power at the socket. There is a power cut. The fuse has blown. Thermostat control is set at „0“.	Check there is power at the socket. Check there is not a power cut by checking the household lights. Check the fuse has not blown. Check the thermostat setting.
The temperature in the appliance is too high	The appliance is located in an unsuitable position. The thermostat control is set too low.	Check the ambient temperature is within the appliances operating limits of 16 °C to 32 °C. Check that the thermostat control knob is turned to the correct setting relative to ambient conditions.
The temperature in the appliance is too low	The thermostat control is set too high.	Set the thermostat control knob to a lower position.
Excessive frost and ice has built up	The door has been left open. Something is obstructing the door. The door gasket is dirty.	Check the door has not been left open. Check nothing is preventing the door from closing. Check the door gasket is intact and clean.
The appliance is noisy.	The appliance is not level.	Check if the appliance stands stable (all four feet should be on the table top).

If after the above checks your appliance still does not operate correctly, contact your local Tricity Bendix Service Force Centre.

Please note that it will be necessary to provide proof of purchase for any in-guarantee service calls.

In-guarantee customers should ensure that the above checks have been made, as the engineer will make a charge if the fault is not a mechanical or electrical breakdown.

Service and Spare Parts

In the event of your appliance requiring service, or if you wish to purchase spare parts please contact your local Tricity Bendix Service Force Centre by telephoning:

0870 5 929929

Your call be routed the Service Force Centre covering your post code area.

For service in the **Republic of Ireland** contact Tricity Bendix
Long Mile Road
Dublin 12

Telephone: 01 4090752.

Before calling out an engineer, please ensure you have read the details under the heading „Something Not Working?“.

When you contact the Service Centre you will need to give the following details:

1. Your name, address and post code
2. Your telephone number
3. Clear and concise details of the fault
4. The model and serial number of the appliance (found on the rating plate)
5. The purchase date

Customer Care Department

For general enquiries concerning your Tricity Bendix appliance or for further information on Tricity Bendix products, you are invited to contact our Customer Care Department by letter or telephone as follows:

Customer Care Department
Tricity Bendix
55-77 High Street
Slough
Berkshire
SL1 1DZ

Tel: 08705 950950 calls to this number may be recorded for training purposes.

Guarantee Conditions

We Tricity Bendix undertake that if within 12 months of the date of the purchase this Tricity Bendix appliance or any part thereof is proved to be defective by reason only of faulty workmanship or materials, the company will, at our option repair or replace the same **FREE OF CHARGE** for labour, materials or carriage on condition that:

- The appliance has been correctly installed and used only on the electrical supply stated on the rating plate.
- The appliance has been used for normal domestic purposes only, and in accordance with the manufacturer's instructions.
- The appliance has not been serviced, maintained, repaired, taken apart or tampered with by any person not authorised by us.
- All service work under this guarantee must be undertaken by a Tricity Bendix Service Force Centre.
- Any appliance or defective part replaced shall become the Company's property.

Home visits are made between **8.30am** and **5.30pm Monday to Friday**. Visits may be available outside these hours in which case a premium will be charged.

EXCLUSIONS

This Guarantee does not cover:

- Damage or calls resulting from transportation, improper use or neglect, the replacement of any light bulbs or removable parts of glass or plastic.
- Costs incurred for calls to put right an appliance improperly installed or calls to appliances outside the United Kingdom.
- Appliances found to be in use within a commercial environment, plus those which are the subject of rental agreements.
- Products of Tricity Bendix manufacture which are not marked by Tricity Bendix.

The guarantee is in addition to your statutory and legal rights.

TRICITY BENDIX EUROPEAN GUARANTEE

If you should move to another country within Europe then your guarantee moves with you to your new home subject to the following qualifications:

- The guarantee starts from the date you first purchased your product.
- The guarantee is for the same period and to the same extent for labour and parts as exists in the new country of use for this brand or range of products.
- This guarantee relates to you and cannot be transferred to another user.
- Your new home is within the European Community (EC) or European Free Trade Area.
- The product is installed and used in accordance with our instructions and is only used domestically, i.e. a normal household.
- The product is installed taking into account regulations in your new country.

Before you move please contact your nearest Customer Care Centre, list below, to give them details of your new home. They will then ensure that the local Service Organisation is aware of your move and able to look after you and your appliances.

France	Senlis	+33 (0) 3 44 62 29 99
Germany	Nuremberg	+49 (0) 911 323 2600
Italy	Pordenone	+39 (0) 1678 47053
Sweden	Stockholm	+46 (0) 8 738 79 50
UK	Slough	+44 (0) 1753 219898

To contact your local Tricity Bendix Service Centre telephone 08705 929 929

CHANNEL ISLANDS		ORKNEY (M65) <i>Corsie Domestics</i> 7 King Street Kirkwall Orkney KW15	NORTH EAST
GUERNSEY	<i>Guernsey Electricity</i> PO Box 4 Vale, Guernsey Channel Islands	PERTH <i>Hydro Electrical</i> Inveralmond House Ruthvenfield Road Perth PH1 3AQ	GATESHEAD (M39) <i>Unit 356a</i> Dukesway Court Dukesway Team Valley Gateshead NE11 0BH
JERSEY	Jersey Electricity Company PO Box 45 Queens Road St Helier Jersey Channel Islands JE4 8NY	PERTH <i>Graham Begg</i> Unit 4 Airport Ind Estate Wick KW1 4QS	GRIMSBY (M42) <i>15 Hainton Avenue</i> Grimsby South Humberside DN32 9AS
SCOTLAND		(OWN SALES)	HULL (M41) <i>Unit 1</i> Boulevard Industrial Estate Hull HU3 4AY
ABERDEEN (M05)	<i>54 Claremont Street</i> Aberdeen AB10 6RA	SHETLAND <i>Tait Electronic Systems Ltd</i> Holmsgarth Road Lerwick Shetland ZE1 0PW	LEEDS (M37) <i>64-66 Cross Gates Road</i> Leeds LS15 7NN
AUCHTERMUCHY (M03)	<i>33a Burnside</i> Auchtermuchy Fife KY14 7AJ	SHETLAND <i>Bolts Shetland Ltd.</i> 26 North Road Lerwick Shetland ZE1 0PE	NEWTON AYCLIFFE (M45) <i>Unit 16</i> Gurney Way Aycliffe Industrial Estate Newton Aycliffe DL5 6UJ
BLANTYRE (M07)	<i>Unit 5</i> Block 2 Auchenraith Ind. Estate Rosendale Way Blantyre G72 0NJ	WHALSAY <i>Leask Electrical</i> Harisdale Symbister, Whalsay Shetland ZE2 9AA	SHEFFIELD (M38) <i>Pennine House</i> Roman Ridge Ind. Roman Ridge Road Sheffield S9 1GB
DUMFRIES (M01)	<i>93 Irish Street</i> Dumfries Scotland DG1 2PQ	NORTHERN IRELAND	
DUNOON (M67)	<i>Brair Hill</i> 7 Hill Street Dunoon Argyll PA23 7AL	BELFAST (M27) <i>Owenmore House</i> Kilwee Business Park Upper Dunmury Lane Belfast BT17 0HD	NORTH WEST
GLASGOW (M04)	<i>20 Cunningham Road</i> Clyde Estate Rutherglen Glasgow G73 1PP	WALES	
INVERNESS (M06)	<i>Unit 3B</i> Smithton Ind. Estate Smithton Inverness IV1 AJ	CARDIFF (M28) <i>Guardian Industrial Estate</i> Clydesmuir Road Tremorfa Cardiff CF2 2QS	CARLISLE (M10) <i>Unit 7</i> James Street Workshops James Street Carlisle Cumbria CA2 5AH
ISLE OF ARRAN (OWN SALES)	<i>Arran Domestics</i> Unit 4 The Douglas Centre Brodrick Isle of Arran KA27 8AJ	CLYWD (M14) <i>Unit 6-7 Coed – Parc</i> Abergele Road Rhuddlan Clwyd Wales LL18 5UG	ISLE OF MAN (M64) <i>South Quay Ind. Estate</i> Douglas Isle of Man IM1 5AT
ISLE OF BARRA (OWN SALES)	<i>J Zerfah</i> 244 Bruernish Isle of Barra Western Islands HS9 5QY	DYFED (M77) <i>Maes Y Coed</i> High Mead Llanybydder Carmarthenshire SA40 9UL	LIVERPOOL (M15) <i>Unit 1</i> Honeys Green Precinct Honeys Green Lane Liverpool L12 9JH
ISLES OF BUTE	<i>Walker Engineering</i> Glenmhor Upper Serpentine Road Rothesay Isle of Bute PA20 9EH	HAVERFORDWEST (M75) <i>Cromlech Lodge</i> Ambleston Haverfordwest Pembrokeshire SA62 5DS	MANCHESTER (M09) <i>Unit B</i> Central Industrial Estate St Marks Street Bolton BL3 6NR
ISLE OF LEWIS	<i>ND Macleod</i> 16 James Street Stornoway Isle of Lewis PA87 2QW	OSWESTRY (M17) <i>Plas Ffynnon</i> Warehouse Middleton Road Oswestry SY11 2PP	PRESTON (M13) <i>Unit 250</i> Dawson Place Walton Summit Bamber Bridge Preston Lancashire PR5 8AL
KELSO (M08)	<i>2-8 Wood Market</i> Kelso Borders TD5 7AX		STOCKPORT (M16) <i>Unit 20 Haigh Park</i> Haigh Avenue Stockport SK4 1QR

To contact your local Tricity Bendix Service Centre telephone 08705 929 929

MIDLANDS		LONDON & EAST ANGLIA		SUNBURY (M63)	Unit 1a The Summit Hanworth Road Hanworth Ind. Estate Sunbury on Thames TW16 5D
BIRMINGHAM (M18)	66 Birch Road East Wyrley Road Ind. Estate Witton Birmingham B6 6DB	BECKENHAM (M79)	11a Gardener Ind. Estate Kent House Lane Beckenham Kent BR3 1QZ	SOUTH EAST	
BOURNE (M44)	Manning Road Ind. Estate Pinfold Road Bourne PE10 9HT	CHELMSFORD (M47)	Hanbury Road Widford Ind. Estate Chelmsford Essex CM12 3AE	ASHFORD (M58)	Unit 2 Bridge Road Business Est. Bridge Road Ashford Kent TN2 1BB
BRIDGNORTH (M72)	68 St. Mary's Street Bridgnorth Shropshire WV16 4DR	COLINDALE (M53)	Unit 14 Capitol Park Capitol Way Colindale London NW9 0EQ	FLEET (M59)	Unit 1 Redsfield Ind. Estate Church Crookham Fleet Hampshire GU13 0RD
GLOUCESTER (M23)	101 Rycroft Street Gloucester GL1 4NB	ELTHAM (M78)	194 Court Road Mottingham Eltham London SE9 4EW	HAYWARDS HEATH (M55)	21-25 Bridge Road Haywards Heath Sussex RH16 1UA
HEREFORD (M31)	Unit 3 Bank Buildings Cattle market Hereford HE4 9HX	ENFIELD (M49)	284 Alma Road Enfield London EN3 7BB	SOUTH WEST	
HIGHAM FERRERS (M51)	30 High Street Higham Ferrers Northants NN10 8BB	GRAVESEND (M57)	Unit B4 Imperial Business Estate Gravesend Kent DA11 0DL	BARNSTAPLE (M30)	Main Road Fremington Barnstaple North Devon EX31 2NT
ILKESTON (M43)	Unit 2 Furnace Road Ilkeston DE7 5EP	HARPENDEN (M46)	Unit 4 Riverside Estate Coldharbour Lane Harpenden AL5 4UN	BOURNEMOUTH (M26)	63-65 Curzon Road Bournemouth Dorset BH1 4PW
LEICESTER (M22)	Unit 7 Oaks Ind. Estate Coventry Road Narborough Leicestershire LE0 5GF	LETCHWORTH (M50)	16-17 Woodside Ind. Estate Works Road Letchworth Herts SG6 1LA	BRIDGEWATER (M35)	6 Hamp Ind. Estate Bridgewater Somerset TA6 3NT
LINCOLN (M40)	Unit 8 Stonefield Park Clifton Street Lincoln LN5 8AA	LONDON (M76)	2/4 Royal Lane Yiewsley West Drayton Middlesex UB7 8DL	BRISTOL (M25)	11 Eldon Way Eldonwall Trading Bristol Avon BS4 3QQ
NEWCASTLE UNDER LYME (M12)	18-21 Croft Road Brampton Ind. Estate Newcastle under Lyme Staffordshire ST5 0TW	MAIDENHEAD (M60)	Reform Road Maidenhead Berkshire SL6 8BY	EMSWORTH (M33)	266 Main Road Southbourne Emsworth PO10 8JL
REDDITCH (M20)	13 Thornhill Road North Moons Moat Redditch Worcestershire B98 9ND	MOLESEY (M61)	10 Island Farm Avenue West Molesey Surrey KT8 2UZ	ISLE OF WIGHT (M34)	Unit 8 Enterprise Court Ryde Business Park Ryde Isle of Wight PO33 1DB
TAMWORTH (M19)	Unit 3 Sterling Park Claymore Tamworth B77 5DO	NEWBURY (M24)	9 Pipers Court Berkshire Drive Thatcham Berkshire RG19 4ER	NEWTON ABBOT (M29)	Unit 2 Zealley Ind. Estate Kingsteignton Newton Abbot S. Devon TQ12 3TD
WORCESTER (M73)	Units 1 & 2 Northbrook Close Gregorys Mill Ind. Estate Worcester WR3 8BP	IPSWICH (M48)	Unit 6C Elton Park Business Centre Hadleigh Road Ipswich IP2 0DD	REDRUTH (M36)	Unit 7D Pool Ind. Estate Wilson Way Redruth Cornwall TR15 3QW
		NORWICH (M52)	2b Trafalgar Street Norwich NR1 3HN		

Instructions for the Installer

Technical data

Model/Type	TB 584 R
Gross capacity (l)	Frozen food comp.: 18 Fresh food comp.: 128
Net capacity (l)	Frozen food comp.: 18 Fresh food comp.: 122
Width (mm)	550
Height (mm)	850
Depth (mm)	600
Energy consumption (kWh/24h) (kWh/year)	0,75 274
Energy class, according to EU standards	B
Star rating of frozen food compartment	****
Freezing capacity (kg/24h)	2
Rising time (h)	11
Rated power (W)	100
Weight (kg)	37

Installing the appliance

Transportation, unpacking

The appliance and the interior fitting are protected for transport.

- Remove all packaging and any adhesive tape.
- Any remnants of adhesive can be removed using white spirit.
- After transportation the appliance must not be switched on for 2 hours. This is to allow the refrigerant to settle.

Cleaning

Clean the accessories and the inside of the appliance with warm water and bicarbonate of soda (5 ml to 0.5 litres of water). Rinse and try thoroughly.

Do not use detergents, abrasive powders, highly perfumed cleaning products, wax polishes or cleaning products containing bleach or alcohol.

Location

The appliance should be positioned in a well ventilated, dry room.

Energy use is affected by the ambient temperature.

The appliance should therefore:

- not be installed next to radiators, cookers or other sources of heat
- only be installed at a location where the ambient temperature corresponds to the climate classification, for which the appliance is designed.

The climate classification can be found on the serial plate.

The following table shows which ambient temperature is correct for each climate classification:

Climate Classification	Ambient Temperature
SN	+10 to +32 °C
N	+16 to +32 °C
ST	+18 to +38 °C

Levelling

The appliance must be level. Level the appliance by adjusting the two adjustable feet (1) at the front of the appliance.

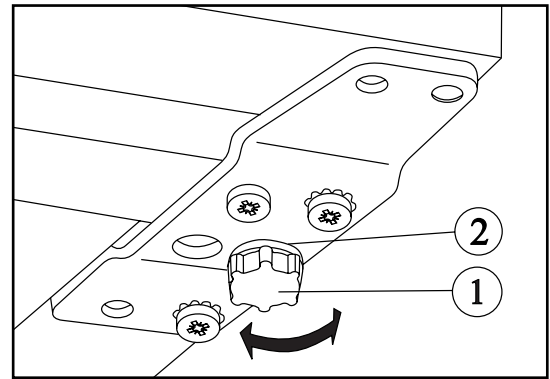

Ventilation Requirements

The appliance must have adequate ventilation to ensure correct operation.

Diagram shows the ventilation requirements when installed:

A:* Under a worktop, or cupboard.

*The clearance space of 10 cm above the appliance may be reduced to 5 cm providing a clearance space 2,5 cm is left on either side of the appliance.

B: When freestanding

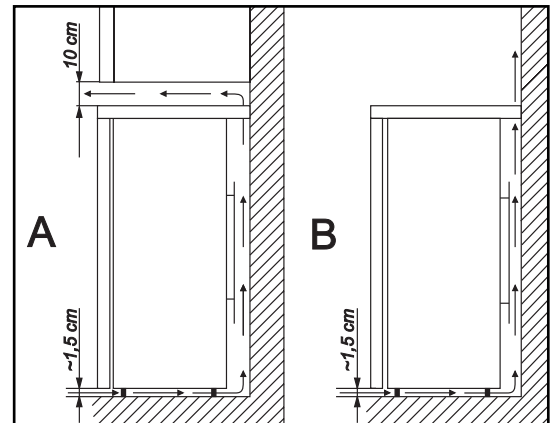

Door Reversal

If required the opening direction of the door can be changed as follows:

To reverse the bottom hinge assembly proceed as follows:

- Disconnect the appliance from the electricity supply.
- Tilt the appliance backwards, resting the top edge of the appliance on a stool or something similar.
- Unscrew the adjustable feet situated on both sides at the front (2 pieces). Remove the lower door hinge plate by unscrewing the 3 retaining screws.
- Remove the hinge pin from the bottom of the door.
- Slot the hinge pin into the hole in the hinge plate and relocate the hinge assembly to the opposite location and refit using the retaining screws.
- Refit the feet into their opposite location.
- Put the cabinet in the upright position.

To reverse the top hinge assembly proceed as follows:

- Remove the 2 worktop retaining screws from the back of the appliance.
- Slide the worktop towards the rear and lift clear of the appliance.
- Remove the 2 upper hinge plate retaining screws.
- Remove the hinge plate from the top of the door.
- Unscrew the hinge pin from the hinge plate and re-insert on the opposite side of the plate.
- Rotate the hinge assembly 180° and insert the hinge assembly into the opposite location.
- Refit the 2 hinge plate retaining screws.
- Relocate the worktop and refit the worktop retaining screws.

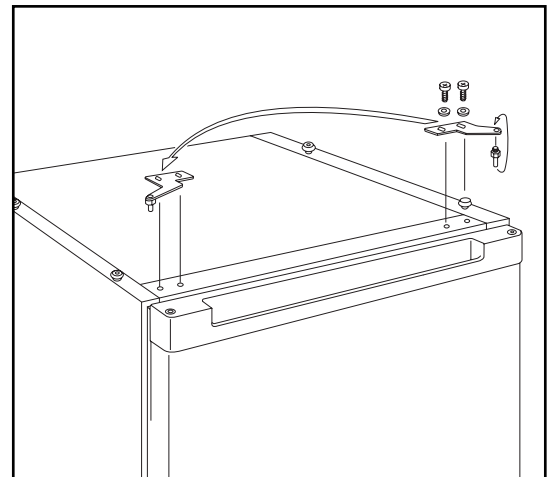
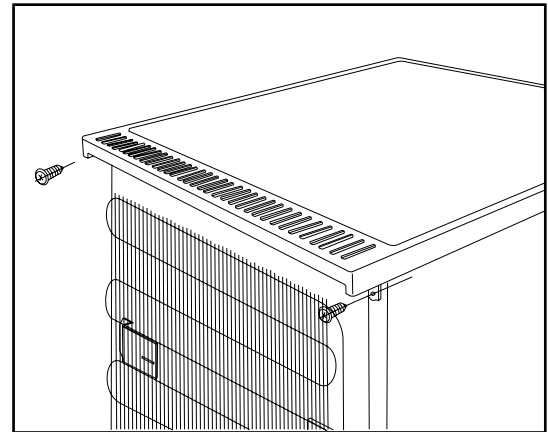
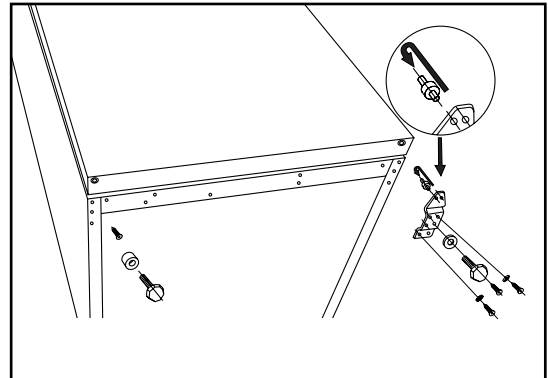

Change of door opening direction of frozen food compartment

After changing the outer door opening direction at this type it is necessary to remount the door of the frozen food compartment as well.

Proceed as follows.

- Pull out the bottom pin holding the door of the frozen food compartment (1).
- Open the door and remove it from the frame carefully (2).
- Take the distance sleeve out of the door and replace it to the other side (3).
- Pull the top pin out of the frame and put it back on the other side (4).
- Remove the door latch (5) and secure on the opposite side.
- Replace the door of the frozen food compartment and secure in place by refitting the bottom hinge pin (6).

In case you do not want to perform the procedures above, call the nearest brand-mark service. Technicians will accomplish the refitting expertly for charge.

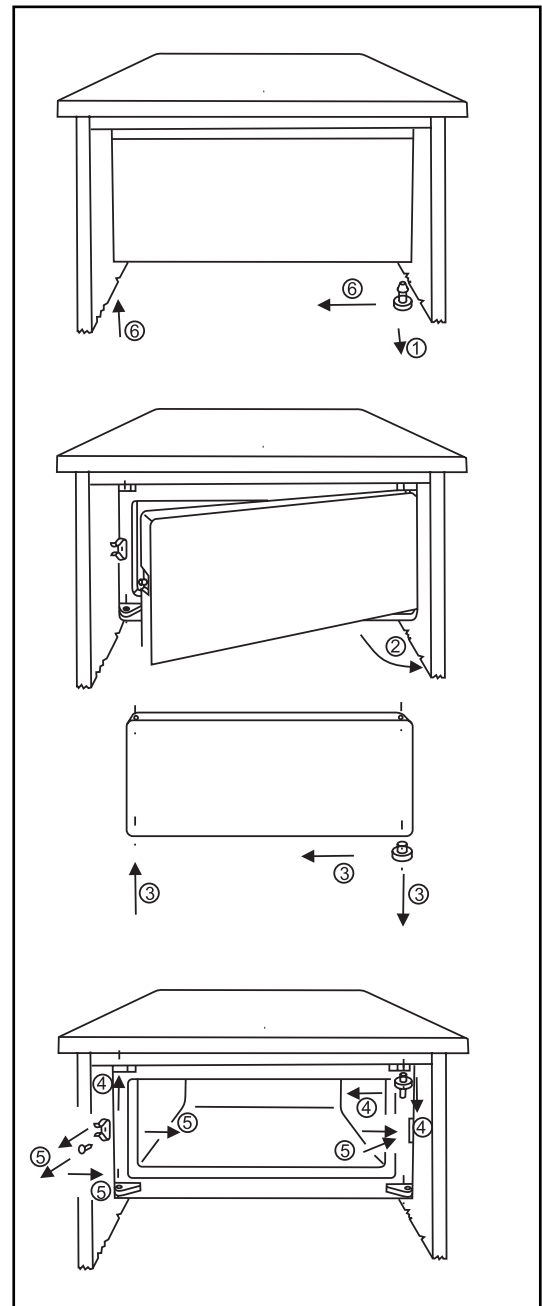

Electrical Connection

 Any electrical work required to install this appliance should be carried out by a qualified electrician or competent person.

This appliance must be earthed.

The manufacturer declines any liability should these safety measures not be observed.

Electrical Requirements

Before switching on, make sure the electricity supply voltage is the same as that indicated on the appliance rating plate.

The appliance is supplied with a 13 amp plug fitted. In the event of having to change the fuse in the plug supplied, a 13 amp ASTA approved (BS 1362) fuse must be used. Should the plug need to be replaced for any reason. The wires in the mains lead are coloured in accordance with the following code:

Green and Yellow: Earth
Blue: Neutral
Brown: Live

The wire coloured green and yellow must be connected to the terminal marked with the letter „E” or by the earth symbol  or coloured green and yellow.

The wire coloured blue must be connected to the terminal „N” or coloured black.

The wire coloured brown must be connected to the terminal marked „L” or coloured red.

Upon completion there must be no cut, or stray strands of wire present and the cord clamp must be secure over the outer sheath.

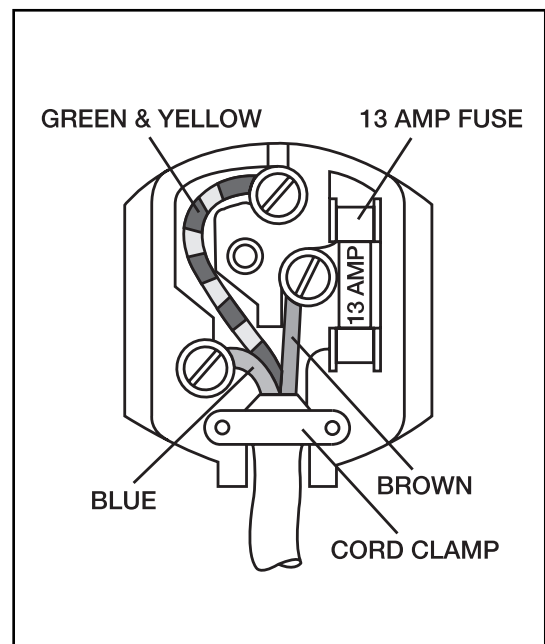

 This appliance complies with the following E.E.C. Directives:

- **73/23 EEC** of 19.02.73 (Low Voltage Directive) and subsequent modifications,
- **89/336 EEC** of 03.05.89 (Electromagnetic Compatibility Directive) and subsequent modifications.

Free Manuals Download Website

<http://myh66.com>

<http://usermanuals.us>

<http://www.somanuals.com>

<http://www.4manuals.cc>

<http://www.manual-lib.com>

<http://www.404manual.com>

<http://www.luxmanual.com>

<http://aubethermostatmanual.com>

Golf course search by state

<http://golfingnear.com>

Email search by domain

<http://emailbydomain.com>

Auto manuals search

<http://auto.somanuals.com>

TV manuals search

<http://tv.somanuals.com>