

Owner's Manual

PowerVerter[®]

APSINT612 (V. 3.0)

DC-to-AC Inverter/Charger



1111 W. 35th Street, Chicago, IL 60609 USA
Customer Support: (773) 869-1212
www.tripplite.com

	Input	Output
Invert:	12 VDC	230V, 50 Hz. AC
Charge:	230V, 50 Hz. AC	12 VDC

Reliable Emergency Backup Power

Congratulations! You've purchased the most advanced, feature-rich Inverter/Charger designed as an alternative energy source during utility power failures. Tripp Lite APS Inverter/Chargers keep your equipment constantly up and productive through all utility power problems (blackouts, brownouts and high voltages) by inverting DC power from user-supplied batteries into AC power. Built-in surge suppression provides an additional level of equipment protection. When utility power is present, APS Inverter/Chargers automatically pass through power to your equipment while simultaneously recharging your connected battery bank. APS Inverter/Chargers are the quiet alternative to gas generators during emergency backup applications—with no fumes, fuel or noise to deal with! You get AC electricity anywhere and anytime you need it.

Better for Your Equipment

Premium Protection Levels

- Built-In Surge Protection
- Automatic Overload Protection

Ideal Output for All Loads (including computers)

- Frequency-Controlled Output
- Fast Load Switching

Better for Your Batteries

Faster Battery Recharge

- High-Amp, 3-Stage Battery Charger (adjustable)

Critical Battery Protection

- High-Efficiency DC-to-AC Inversion

Better for You

Simple, Maintenance-Free Operation

- Multi-Function Lights & Switches
- Moisture-Resistant Construction*

Contents

Specifications/Warranty	2	Battery Selection	7
Safety Instructions	3	Mounting	8
Feature Identification	4	Battery Connection	9
Operation	5	AC Input/Output Connection	10
Configuration	6	Service/Maintenance	10
		Troubleshooting	11

* Inverter/Chargers are moisture-resistant, not waterproof.

Copyright © 2003. PowerVerter[®] is a registered trademark of Tripp Lite. All rights reserved.
Download from www.Somanuals.com. All Manuals Search And Download.

Specifications

MODEL NUMBER:
AC Input Connection:

APSINT612
Detachable Input Cord

INVERTER

Output Volts (Nominal):	230 VAC, ± 5%
Output Frequency (Nominal):	50 Hz, ± 0.5%
Efficiency:	88% to 94%, depending on load and temperature
Continuous Power (@ 20 C):	600
OverPower™ Peak Surge Power:*	900
Double Boost™ Peak Surge Power:*	1200
DC Input Volts (Nominal):	12 VDC
DC Input Voltage Range:	10-15 VDC
Minimum DC Fuse Rating:	100 A
DC Input Current @ Nominal V DC Full Load:	56 A

BATTERY CHARGER

Input Volts (Nominal):	230 VAC
Charging Capacity DC:	20 A
Acceptance Volts VDC Selectable (Wet**/Gel):	14.4 V (14.2 V)
Float Volts VDC (w/gel):	13.3 V (13.6 V)
Input Current AC (Maximum):	2.2 A

LINE VAC OPERATION

Minimum Input Volts (Transfer to Battery):	Selectable 144,** 163, 182 or 201 VAC
Maximum Input Volts (Transfer to Battery):	Selectable 259** or 278 VAC
Input Frequency (Nominal):	50 Hz, ±10%
Total Input AC Current (Continuous, Charger at Maximum):	4.8 A
Maximum Output Current (Continuous):	2.6 A

* OverPower duration (up to 1 hour), DoubleBoost duration (up to 10 seconds). Actual duration depends on battery age, battery charge level and ambient temperature. ** Factory setting. The policy of Tripp Lite is one of continuous improvement. Specifications are subject to change without notice.

Minimum Recommended Cable Sizing Charts†

Use in conjunction with DC wiring connection instructions in the Battery Connection section.

Inverter/Charger DC Volt: 12

Watts	Wire Gauge				
	6	4	2	0	00 (2/0)
500	4.8 m (15 ft)	7.6 m (25 ft)	11.9 m (39 ft)	18.9 m (62 ft)	24.1 m (79 ft)
700	3.4 m (11 ft)	5.5 m (18 ft)	8.5 m (28 ft)	13.4 m (44 ft)	17.1 m (56 ft)

† NOTE: Acceptable power is directly related to cable length (i.e. - the shorter the cable, the better the performance)

Note on Labeling

Two symbols are used on the APS labels.
V~: AC Voltage — : DC Voltage

Limited Warranty

Tripp Lite warrants its Inverter/Chargers to be free from defects in materials and workmanship for a period of one year (except for outside of U.S.A., Canada and Mexico—120 days) from the date of retail purchase by end user

Tripp Lite's obligation under this warranty is limited to repairing or replacing (at its sole option) any such defective products. To obtain service under this warranty you must obtain a Returned Material Authorization (RMA) number from Tripp Lite or an authorized Tripp Lite service center. Products must be returned to Tripp Lite or an authorized Tripp Lite service center with transportation charges prepaid and must be accompanied by a brief description of the problem encountered and proof of date and place of purchase. This warranty does not apply to equipment which has been damaged by accident, negligence or misapplication or has been altered or modified in any way, including opening of the unit's casing for any reason. This warranty applies only to the original purchaser who must have properly registered the product within 10 days of retail purchase.

EXCEPT AS PROVIDED HEREIN, TRIPP LITE MAKES NO WARRANTIES, EXPRESS OR IMPLIED, INCLUDING WARRANTIES OF MERCHANTABILITY AND FITNESS FOR A PARTICULAR PURPOSE. Some states do not permit limitation or exclusion of implied warranties; therefore, the aforesaid limitation(s) or exclusion(s) may not apply to the purchaser.

EXCEPT AS PROVIDED ABOVE, IN NO EVENT WILL TRIPP LITE BE LIABLE FOR DIRECT, INDIRECT, SPECIAL, INCIDENTAL OR CONSEQUENTIAL DAMAGES ARISING OUT OF THE USE OF THIS PRODUCT, EVEN IF ADVISED OF THE POSSIBILITY OF SUCH DAMAGE. Specifically, Tripp Lite is not liable for any costs, such as lost profits or revenue, loss of equipment, loss of use of equipment, loss of software, loss of data, costs of substitutes, claims by third parties, or otherwise.

Tripp Lite has a policy of continuous improvement. Specifications are subject to change without notice.



SAVE THESE INSTRUCTIONS!

This manual contains important instructions and warnings that should be followed during the installation, operation and storage of all Tripp Lite Inverter/Chargers.

Location Warnings

- Install your Inverter/Charger (whether for a mobile or stationary application) in a location or compartment that minimizes exposure to heat, dust, direct sunlight and moisture.
- Although your Inverter/Charger is moisture resistant, it is NOT waterproof. Flooding the unit with water will cause it to short circuit and could cause personal injury due to electric shock. Never immerse the unit, and avoid any area where standing water might accumulate. Mounting should be in the driest location available.
- Leave a minimum of 5 cm (2") clearance at front and back of the Inverter/Charger for proper ventilation. The heavier the load of connected equipment, the more heat will be generated by the unit.
- Do not install the Inverter/Charger directly near magnetic storage media, as this may result in data corruption.
- Do not install near flammable materials, fuel or chemicals.

Battery Connection Warnings

- The Inverter/Charger will not operate (with or without utility power) until batteries are connected.
- Multiple battery systems must be comprised of batteries of identical voltage, age, amp-hour capacity and type.
- Because explosive hydrogen gas can accumulate near batteries if they are not kept well ventilated, your batteries should not be installed (whether for a mobile or stationary application) in a “dead air” compartment. Ideally, any compartment would have some ventilation to outside air.
- Sparks may result during final battery connection. Always observe proper polarity as batteries are connected.
- Do not allow objects to contact the two DC input terminals. Do not short or bridge these terminals together. Serious personal injury or property damage could result.

Equipment Connection Warnings

Do not use a Tripp Lite APS Inverter/Charger in life support or healthcare applications where a malfunction or failure of a Tripp Lite APS Inverter/Charger could cause failure of or significantly alter the performance of, a life support device or medical equipment.

- Do not modify the Inverter/Charger's plug or receptacle in a way that eliminates its ground connection. Do not use power adapters that will eliminate the plug's ground connection.
- Connect your Inverter/Charger only to a properly grounded AC power outlet. Do not plug the unit into itself; this will damage the device and void your warranty.
- You may experience uneven performance results if you connect a surge suppressor, line conditioner or UPS system to the output of the Inverter/Charger.

Operation Warnings

- Your Inverter/Charger does not require routine maintenance. Do not open the device for any reason. There are no user serviceable parts inside.
- Potentially lethal voltages exist within the Inverter/Charger as long as the battery supply and/or AC input are connected. During any service work, the battery supply and AC input connection should therefore be disconnected.
- Do not connect or disconnect batteries while the Inverter/Charger is operating in either inverting or charging mode. Operating Mode Switch should be in the OFF position. Dangerous arcing may result.

Feature Identification

Identify the premium features on your specific model and quickly locate instructions on how to maximize their use.

- 1 Configuration DIP Switches:** optimize Inverter/Charger operation depending on your application. See page 6 for setting instructions.
- 2 Operating Mode Switch:** controls Inverter/Charger operation. The “AUTO/REMOTE” setting ensures your equipment receives constant, uninterrupted AC power. It also enables the Inverter/Charger to be remotely monitored and controlled with an optional remote module (Tripp Lite model APSRM2, sold separately). The “CHARGE ONLY” setting allows your batteries to return to full charge faster by turning the inverter off which halts battery discharging. See page 5 for setting instructions.
- 3 Operation Indicator Lights:** intuitive “traffic light” signals show whether the Inverter/Charger is operating from AC line power or DC battery power. It also warns you if the connected equipment load is too high. See page 5 for instructions on reading indicator lights.
- 4 Battery Indicator Lights:** intuitive “traffic light” signals show approximate charge level of your battery. See page 5 for instructions on reading indicator lights.
- 5 DC Power Terminals:** connect to your battery terminals. See page 9 for connection instructions.
- 6 AC Output Receptacles:** allow you to connect equipment that would normally be plugged into a utility outlet. A universal adapter, included, allows you to connect a wide variety of plug styles to the NEMA receptacle. See page 10 for connection instructions.
- 7 AC Input Receptacle:** connects the Inverter/Charger to any source of utility- or generator-supplied AC power. See page 10 for connection instructions.
- 8 Resettable Circuit Breakers:** protect your Inverter/Charger against damage due to overload. See page 5 for resetting instructions.
- 9 Remote Control Module Connector:** allows remote monitoring and control with an optional module (Tripp Lite model APSRM2, sold separately). See remote module owner’s manual for connection instructions.
- 10 Main Ground Lug:** properly grounds the Inverter/Charger to earth ground or to vehicle or boat grounding system. See page 9 for connection instructions.
- 11 Multi-Speed Cooling Fan:** quiet, efficient fan prolongs equipment service life.

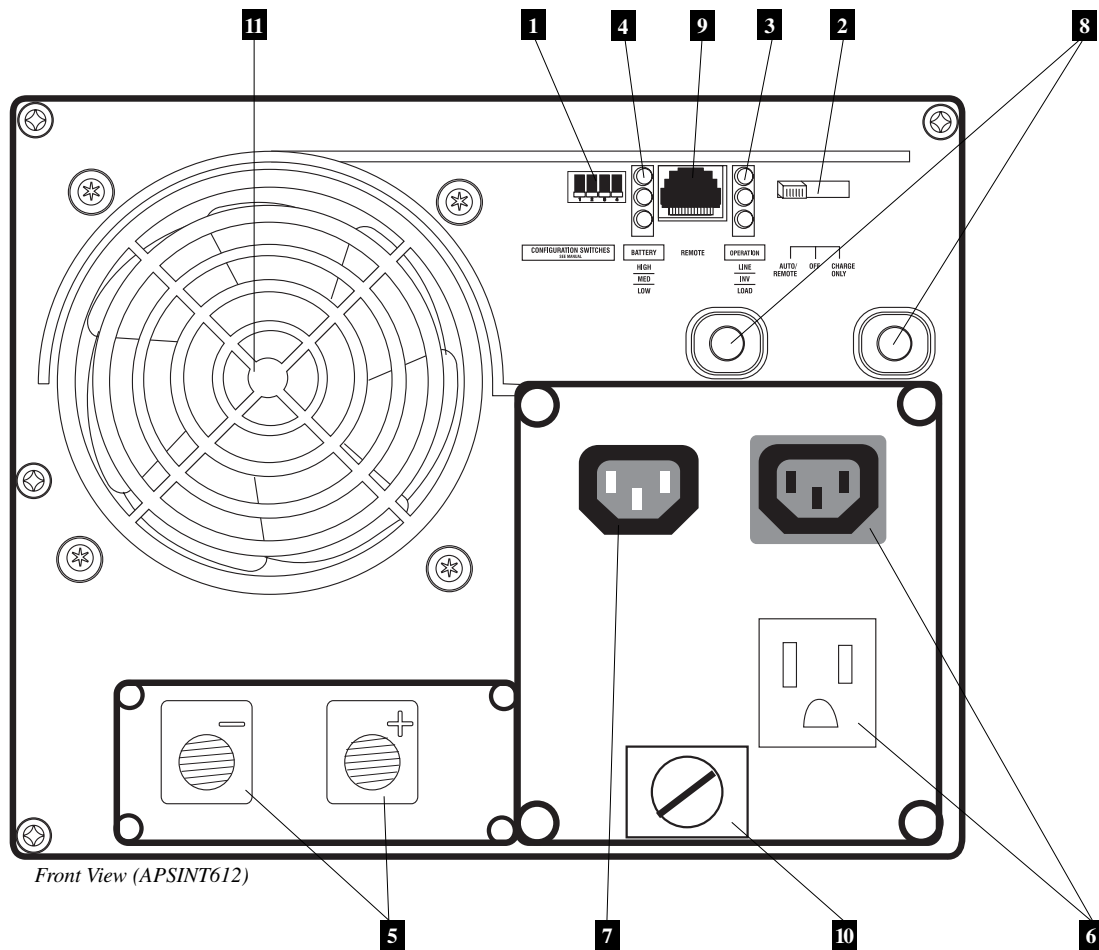

Operation

Switch Modes

After configuring, mounting and connecting your Inverter/Charger, you are able to operate it by switching between the following operating modes as appropriate to your situation:

AUTO/REMOTE: Switch to this mode when you need constant, uninterrupted AC power for connected appliances and equipment. The Inverter/Charger will continue to supply AC power to connected equipment and to charge your connected batteries while utility- or generator-supplied AC power is present. Since the inverter is ON (but in Standby) in this mode, it will automatically switch to your battery system to supply AC power to connected equipment in the absence of a utility/generator source or in over/under voltage situations. "AUTO/REMOTE" also enables an optional remote control module (Tripp Lite model APSRM2, sold separately) to function when connected to the unit.

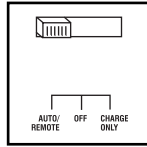

CHARGE ONLY: Switch to this mode when you are not using connected appliances and equipment in order to conserve battery power by disabling the inverter. The Inverter/Charger will continue to supply AC power to connected equipment and charge connected batteries while utility- or generator-supplied AC power is present. However, since the inverter is OFF in this mode, it WILL NOT supply AC power to connected equipment in the absence of a utility/generator source or in over/under voltage situations.

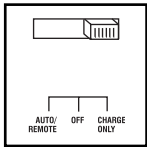

OFF: Switch to this mode to shut down the Inverter/Charger completely, preventing the inverter from drawing power from the batteries, and preventing utility AC from passing through to connected equipment or charging the batteries. Use this switch to automatically reset the unit if it shuts down due to overload or overheating. First remove the excessive load or allow the unit to sufficiently cool (applicable to your situation). Switch to "OFF", then back to "AUTO/REMOTE" or "CHARGE ONLY" as desired. If unit fails to reset, remove more load or allow unit to cool further and retry. Use an optional remote control module (Tripp Lite model APSRM2, sold separately) to reset unit due to overload only.

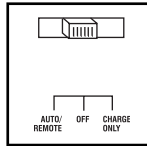

Indicator Lights

Your Inverter/Charger (as well as an optional Tripp Lite Remote Control Module, sold separately) is equipped with a simple, intuitive, user-friendly set of indicator lights. These easily-remembered "traffic light" signals will allow you, shortly after first use, to tell at a glance the charge condition of your batteries, as well as ascertain operating details and fault conditions.

LINE Green Indicator: If the operating mode switch is set to "AUTO/REMOTE," this light will ILLUMINATE CONTINUOUSLY when your connected equipment is receiving continuous AC power supplied from a utility/generator source.

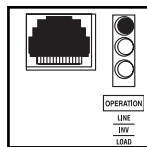

If the operating mode switch is set to "CHARGE ONLY," this light will FLASH to alert you that the unit's inverter is OFF and will NOT supply AC power in the absence of a utility/generator source or in over/under voltage situations.

INV (Inverting) Yellow Indicator: This light will ILLUMINATE CONTINUOUSLY whenever connected equipment is receiving battery-supplied, inverted AC power (in the absence of a utility/generator source or in over/under voltage situations). This light will be off when AC power is supplying the load.

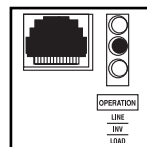

LOAD Red Indicator: This red light will ILLUMINATE CONTINUOUSLY whenever the inverter is functioning and the power demanded by connected appliances and equipment exceeds 100% of load capacity. The light will FLASH to alert you when the inverter shuts down due to a severe overload or overheating. If this happens, turn the operating mode switch "OFF"; remove the overload and let the unit cool. You may then turn the operating mode switch to either "AUTO/REMOTE" or "CHARGE ONLY" after it has adequately cooled. This light will be off when AC power is supplying the load.

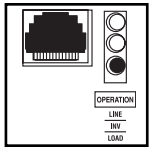

BATTERY Indicator Lights: These three lights will illuminate in several sequences to show the approximate charge level of your connected battery bank and alert you to two fault conditions:

Approximate Battery Charge Level*

Indicator Illuminated	Battery Capacity (Charging/Discharging)
1 Green	91%–Full
2 Green & Yellow	81%–90%
3 Yellow	61%–80%
4 Yellow & Red	41%–60%
5 Red	21%–40%
6 All three lights off	1%–20%
7 Flashing red	0% (Inverter shutdown)

* Charge levels listed are approximate. Actual conditions vary depending on battery condition and load.

Fault Condition

Indicator Illuminated	Fault Condition
1 All three lights flash slowly*	Excessive discharge (Inverter shutdown)
2 All three lights flash quickly**	Overcharge (Charger shutdown)

*Approximately 1/2 second on, 1/2 second off. See Troubleshooting section. **Approximately 1/4 second on, 1/4 second off. May also indicate a battery charger fault exists. See Troubleshooting section.

Resetting Your Inverter/Charger to Restore AC Power

Your Inverter/Charger may cease supplying AC power or DC charging power in order to protect itself from overload or to protect your electrical system. To restore normal functioning:

Overload Reset: Switch operating mode switch to "OFF" and remove some of the connected electrical load (ie: turn off some of the AC devices drawing power which may have caused the overload of the unit). Wait one minute, then switch operating mode switch back to either "AUTO/REMOTE" or "CHARGE ONLY."

Output Circuit Breaker Reset: Alternatively, check output circuit breaker(s) on the unit's front panel. If tripped, remove some of the electrical load, then wait one minute to allow components to cool before resetting the circuit breaker. See Troubleshooting for other possible reasons AC output may be absent.

Configuration

Set Configuration DIP Switches

Using a small tool, set the Configuration DIP Switches (located on the front panel of your unit, see diagram) to optimize Inverter/Charger operation depending on your application.

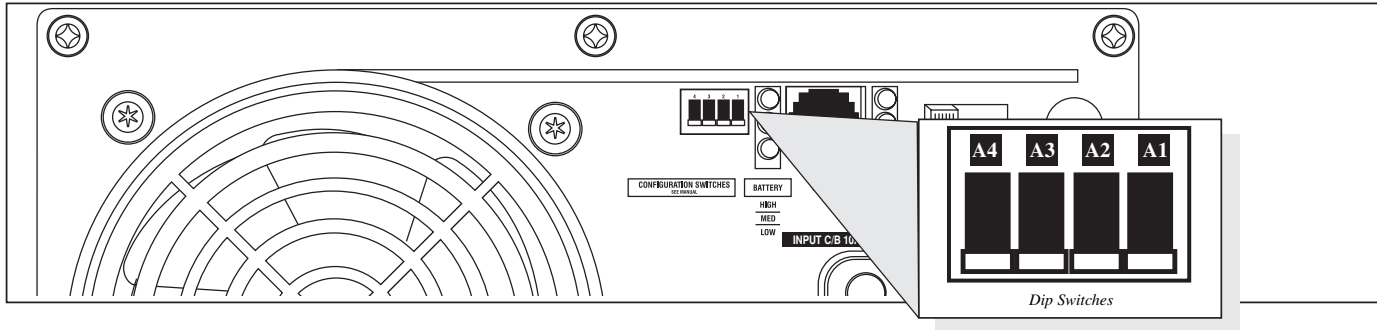

DIP Switches

A1 Select Battery Type—REQUIRED

CAUTION: The Battery Type DIP Switch setting must match the type of batteries you connect, or your batteries may be degraded or damaged over an extended period of time. See "Battery Selection," p. 7 for more information.

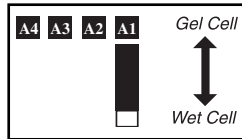

Battery Type	Switch Position
Gel Cell (Sealed) Battery	Up
Wet Cell (Vented) Battery	Down (factory setting)

A2 Select High AC Input Voltage Point for Switching to Battery—OPTIONAL*

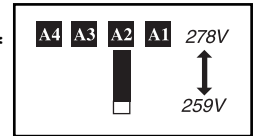

Voltage	Switch Position
278V	Up
259V	Down (factory setting)

A4 A3 Select Low AC Input Voltage Point for Switching to Battery—OPTIONAL*

Voltage	Switch Position
201V	#A4 Up & #A3 Up
182V	#A4 Up & #A3 Down
163V	#A4 Down & #A3 Up
144V	#A4 Down & #A3 Down (factory setting)

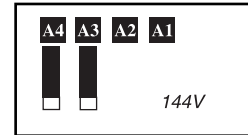
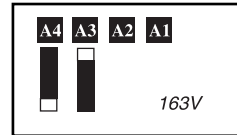
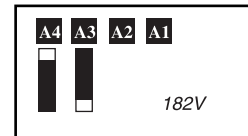
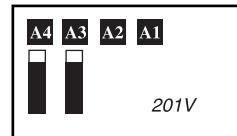

* Most of your connected appliances and equipment will perform adequately when your Inverter/Charger's High AC Input Voltage Point is left in the factory setting and its Low AC Voltage Input Point is set to 182V. However, if the unit frequently switches to battery power due to momentary high/low line voltage swings that would have little effect on equipment operation, you may wish to adjust these settings. By increasing the High AC Voltage Point and/or decreasing the Low AC Voltage Point, you will reduce the number of times your unit switches to battery due to voltage swings.

Connect Remote Control—Optional

All models feature an 8-conductor telephone style receptacle on the front panel for use with an optional remote control module (Tripp Lite model APSRM2, sold separately). The remote module allows the Inverter/Charger to be mounted in a compartment or cabinet out of sight, while operated conveniently from a remote location. See instructions packed with the remote control module.

Battery Selection

Select Battery Type

Select "Deep Cycle" batteries to enjoy optimum performance from your Inverter/Charger. Batteries of either Wet-Cell (vented) or Gel-Cell /Absorbed Glass Mat (sealed) construction are ideal. 6-volt "golf cart," Marine Deep-Cycle or 8D Deep-Cycle batteries are also acceptable. You must set the Inverter/Charger's Battery Type DIP Switch (see Configuration section for more information) to match the type of batteries you connect or your batteries may be degraded or damaged over an extended period of time.

Match Battery Amp-Hour Capacity to Your Application

Select a battery or system of batteries that will provide your Inverter/Charger with proper DC voltage and an adequate amp-hour capacity to power your application. Even though Tripp Lite Inverter/Chargers are highly-efficient at DC-to-AC inversion, their rated output capacities are limited by the total amp-hour capacity of connected batteries plus the output of an alternator when one is used.

• STEP 1) Determine Total Wattage Required

Add the wattage ratings of all equipment you will connect to your Inverter/Charger. Wattage ratings are usually listed in equipment manuals or on nameplates. If your equipment is rated in amps, multiply that number times AC utility voltage to estimate watts. (Example: a ¼ in. drill requires 1.3 amps. $1.3 \text{ amps} \times 230 \text{ volts} = 300 \text{ watts}$.)

NOTE: Your Inverter/Charger will operate at higher efficiencies at about 75% - 80% of nameplate rating.

Example

Tools

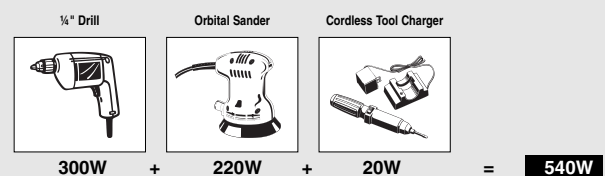

Appliances

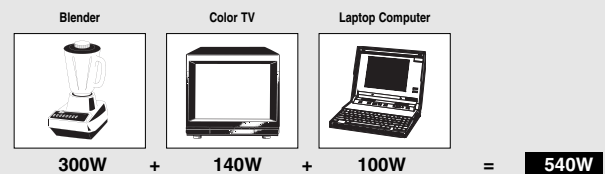

• STEP 2) Determine DC Battery Amps Required

Divide the total wattage required (from step 1, above) by the battery voltage (12) to determine the DC amps required.

$$540 \text{ watts} \div 12\text{V} = \mathbf{45 \text{ DC Amps}}$$

• STEP 3) Estimate Battery Amp-Hours Required

Multiply the DC amps required (from step 2, above) by the number of hours you estimate you will operate your equipment exclusively from battery power before you have to recharge your batteries with utility- or generator-supplied AC power. Compensate for inefficiency by multiplying this number by 1.2. This will give you a rough estimate of how many amp-hours of battery power (from one or several batteries) you should connect to your Inverter/Charger.

NOTE: Battery amp-hour ratings are usually given for a 20-hour discharge rate. Actual amp-hour capacities are less when batteries are discharged at faster rates. For example, batteries discharged in 55 minutes provide only 50% of their listed amp-hour ratings, while batteries discharged in 9 minutes provide as little as 30% of their amp-hour ratings.

$$45 \text{ DC Amps} \times 5 \text{ Hrs. Runtime} \\ \times 1.2 \text{ Inefficiency Rating} = \mathbf{270 \text{ Amp-Hours}}$$

• STEP 4) Estimate Battery Recharge Required, Given Your Application

You must allow your batteries to recharge long enough to replace the charge lost during inverter operation or else you will eventually run down your batteries. To estimate the minimum amount of time you need to recharge your batteries given your application, divide your required battery amp-hours (from step 3, above) by your Inverter/Charger's rated charging amps (see Specifications section).

NOTE: For Tripp Lite Inverter/Chargers providing 1000 watts or less of continuous AC power, a full-size battery will normally allow sufficient power for many applications before recharging is necessary. For mobile applications, if a single battery is continuously fed by an alternator at high idle or faster, then recharging from utility or generator power may not be necessary. Tripp Lite Inverter/Chargers will provide adequate power for ordinary usage within limited times without the assistance of utility or generator power. However, when operating extremely heavy electrical loads at their peak in the absence of utility power, you may wish to "assist your batteries" by running an auxiliary generator or vehicle engine, and doing so at faster than normal idling.

$$270 \text{ Amp-Hours} \div 20 \text{ Amps} \\ \text{Inverter/Charger Rating} = \mathbf{13.5 \text{ Hours Recharge}}$$

Mounting



WARNING! Mount your Inverter/Charger BEFORE DC battery and AC power connection. Failure to follow these instructions may lead to personal injury and/or damage to the Inverter/Charger and connected systems.

Tripp Lite manufactures a variety of different Inverter/Chargers with a variety of different mounting options for use in vehicular or non-vehicular applications. Tripp Lite recommends permanent mounting of your Inverter/Charger in any of the configurations illustrated below. User must supply mounting hardware and is responsible for determining if the hardware and mounting surface are suitable to support the weight of the Inverter/Charger. Contact Tripp Lite if you require further assistance in mounting your Inverter/Charger.

Vehicular and Non-Vehicular Horizontal Mount

A Install two user-supplied 6 mm (1/4") fasteners into a rigid horizontal surface, leaving the heads slightly raised. **B** Slide the Inverter/Charger back over the fasteners to engage the mounting slots molded on the bottom of the Inverter/Charger cabinet. **C** Install and tighten two user-supplied 6 mm (1/4") fasteners into the mounting feet molded on the front of the Inverter/Charger cabinet.

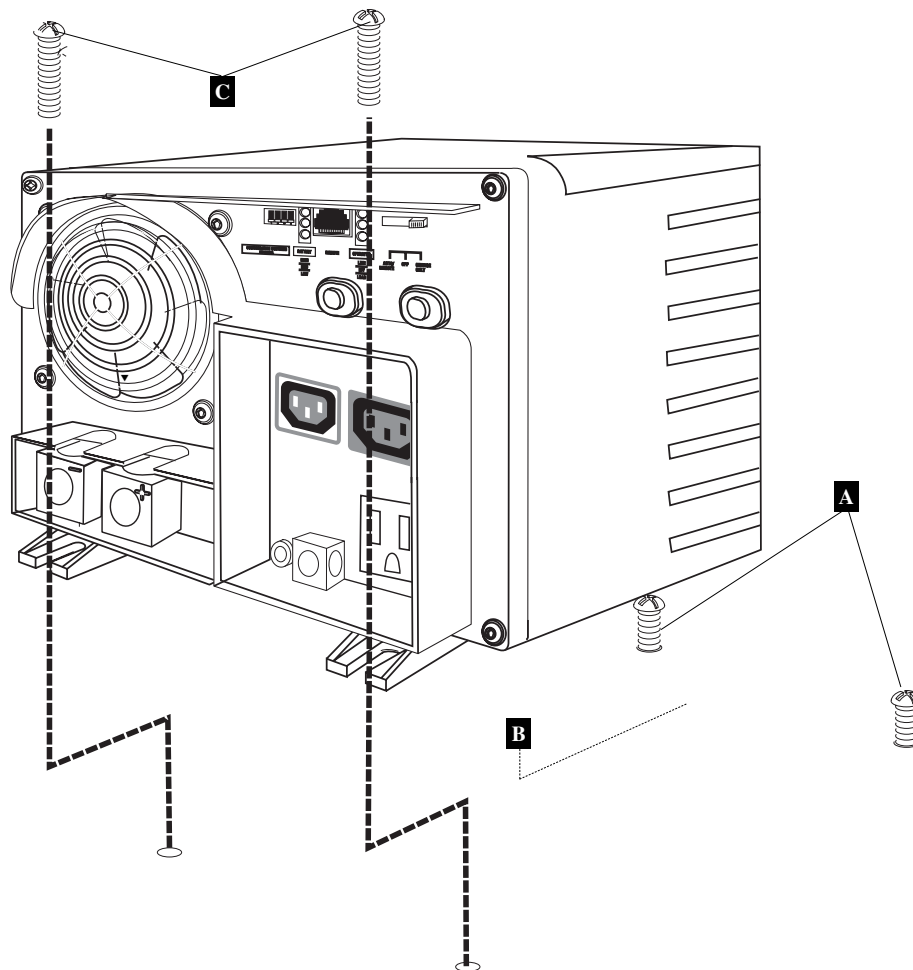

Battery Connection

Connect your Inverter/Charger to your batteries using the following procedures:

• **Connect DC Wiring:** Though your Inverter/Charger is a high-efficiency converter of electricity, its rated output capacity is limited by the length and gauge of the cabling running from the battery to the unit.

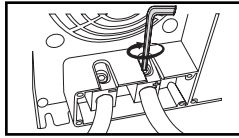

DC Connectors

Use the shortest length and largest diameter cabling (maximum 2/0 gauge) to fit your Inverter/Charger's DC Input terminals. Shorter and heavier gauge cabling reduces DC voltage drop and allows for maximum transfer of current. Your Inverter/Charger is capable of delivering peak wattage at up to 200% of its rated continuous wattage output for brief periods of time. See Specifications page for details. Heavier gauge cabling should be used when continuously operating heavy draw equipment under these conditions. Tighten your Inverter/Charger and battery terminals to approximately 3.5 Newton-meters of torque to create an efficient connection and to prevent excessive heating at this connection. Insufficient tightening of the terminals could void your warranty. See Specifications page for Minimum Recommended Cable Sizing Chart.

• **Connect Ground:** Using a #8 AWG wire or larger directly connect the Main Ground Lug to the vehicle's chassis or earth ground. See the Feature Identification section to locate the Main Ground Lug on your specific Inverter/Charger model. All installations must comply with national and local codes and ordinances.

• **Connect Fuse:** NEC (National Electrical Code) article 551 requires that you connect all of your Inverter/Charger's positive DC Terminals directly to a UL-listed fuse(s) and fuse block(s) within 45 cm (18 inches) of the battery. The fuse's rating must equal or exceed the Minimum DC Fuse Rating listed in your Inverter/Charger's specifications. See Specifications for fuse and fuse block recommendations. See diagrams below for proper fuse placement.

WARNING!



- Failure to properly ground your Inverter/Charger to a vehicle's chassis or earth ground may result in a lethal electrical shock hazard.
- Never attempt to operate your Inverter/Charger by connecting it directly to output from an alternator rather than a battery or battery bank.
- Observe proper polarity with all DC connections.

Non-Vehicular or Vehicular

Non-vehicular applications include stationary configurations as well as mobile configurations that are not integrated into a vehicle's electrical system. In a parallel connection, your Inverter/Charger's Nominal DC Input Voltage (listed in the Specifications section **must match** the voltage of your battery or batteries. For example, a 12V DC Inverter/Charger would require 12V DC from your battery system.

In a series connection, your Inverter/Charger's Nominal DC Input Voltage **must match** the number of batteries multiplied by their voltage. For example, a 12V DC Inverter/Charger would require two 6V batteries connected in series ($12 = 2 \times 6$).

In vehicular applications, your Inverter/Charger's Nominal DC Input Voltage **must match** the voltage of your battery or batteries—12 Volts. Although it is possible to connect your Inverter/Charger to the main battery within your vehicle's electrical system, in the normal vehicular context, the Inverter/Charger is connected to one or more dedicated auxiliary (house) batteries which are isolated from the drive system to prevent possible draining of the main battery.

Contact Tripp Lite technical support for assistance with additional parallel, series or series/parallel connections.

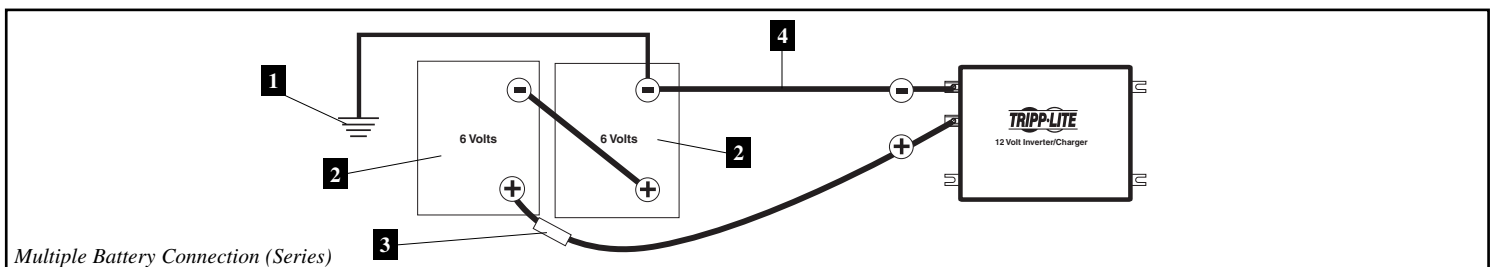
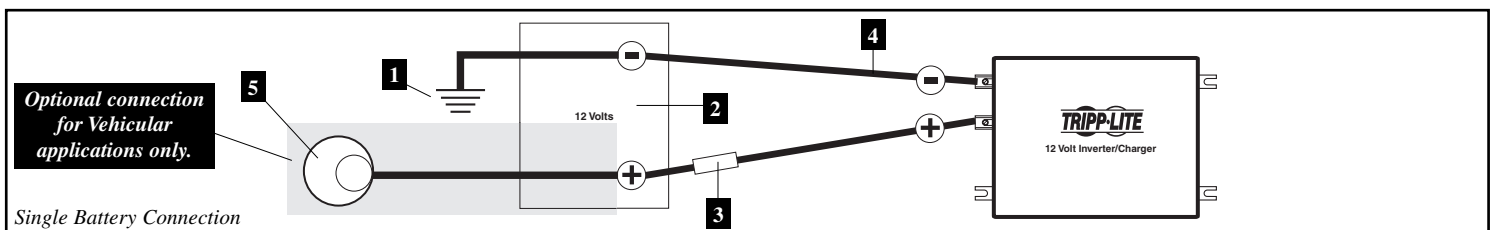

- 1 Earth or Vehicle/Boat Battery Ground 2 Battery 3 UL-Listed Fuse & Fuse Block [mounted within 45 cm (18 inches) of the battery] 4 Large Diameter Cabling, Maximum 2/0 Gauge to Fit Terminals 5 Alternator (for vehicle or boat connection only)

AC Input/Output Connection

To avoid overloading your Inverter/Charger, be sure to match the power requirements of the equipment you plan to run at any one time (add their total watts) with the output wattage capacity of your Inverter/Charger model (see Specifications). When figuring the power requirements of your equipment, do not confuse “continuous” wattage with “peak” wattage ratings. Most electric motors require extra power at start-up (“peak” wattage) than required to run continuously after start-up, sometimes over 100% more. Some motors, such as in refrigerators and pumps, start and stop intermittently according to demand, requiring “peak” wattage at multiple, unpredictable times during operation.

- **DoubleBoost™ Feature**

Tripp Lite Inverter/Chargers deliver up to twice their nameplate rated wattage for up to 10 seconds,* providing the extra power needed to cold start heavy-duty tools and equipment.

- **OverPower™ Feature**

Tripp Lite Inverter/Chargers deliver up to 150% of their nameplate rated wattage for up to 1 hour,* providing plenty of reserve power to reliably support tools and equipment longer.

** Actual duration depends on battery age, battery charge level and ambient temperature.*

AC Input Connection

Connect one end of the detachable 2 meter power cord, included, into the IEC-320 AC Input receptacle. Connect the other end to your wall outlet. If the plug on the cord does not match your wall receptacle, you can remove a detachable cord from another piece of equipment (such as a computer or monitor) that does have the appropriate plug and use that as the Inverter/Charger power cord. Then use the included detachable 2 meter cord to connect the piece of equipment, whose cord you've removed, to the NEMA 5-15R output receptacle on the Inverter/Charger.

AC Output Connection

Simply connect equipment directly to the IEC-320 and NEMA output receptacles. A universal adapter, included, allows you to connect a wide variety of plug styles to the NEMA receptacle.

Service

If you are returning your Inverter/Charger to Tripp Lite, please pack it carefully, using the ORIGINAL PACKING MATERIAL that came with the unit. Enclose a letter describing the symptoms of the problem. If the Inverter/Charger is within the warranty period, enclose a copy of your sales receipt. To obtain service you must obtain a Returned Material Authorization (RMA) number from Tripp Lite or an authorized Tripp Lite service center.

Maintenance

Your Inverter/Charger requires no maintenance and contains no user-serviceable or replaceable parts, but should be kept dry at all times. Periodically check, clean and tighten all cable connections as necessary, both at the unit and at the battery.

Troubleshooting

Try these remedies for common Inverter/Charger problems before calling for assistance. Call Tripp Lite Customer Service at (773) 869-1212 before returning your unit for service.

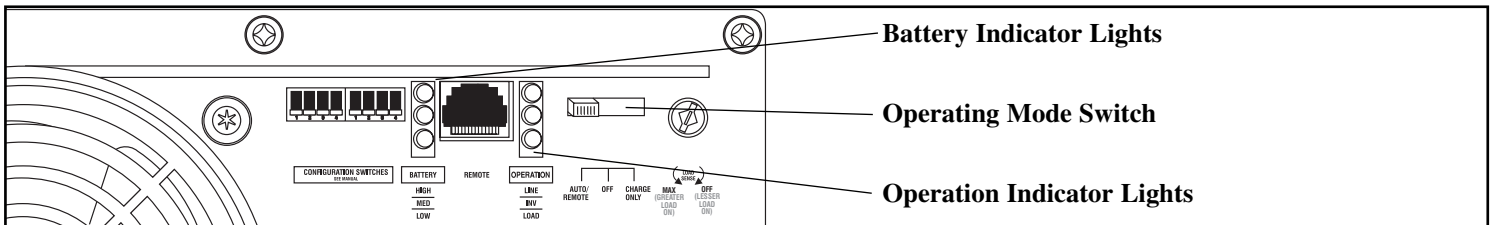

SYMPTOM	PROBLEMS	CORRECTIONS
No AC Output (All Indicator Lights Are OFF)	Unit is not properly connected to utility power.	Connect unit to utility power.
	Operating Mode Switch is set to "OFF" and AC input is present.	Set Operating Mode Switch to "AUTO/REMOTE" or "CHARGE ONLY."
	This is normal when the Operating Mode Switch is set to "CHARGE ONLY" and AC input is absent.	No correction is required. AC output will return when AC input returns. Set Operating Mode Switch to "AUTO/REMOTE" if you require AC output.
	Circuit breaker is tripped.	Reset circuit breaker.
	Unit has shut down due to battery overcharge (preventing battery damage). The problem may be with connected auxiliary chargers, if any, or with the unit's charger.	Disconnect any auxiliary chargers. Reset by moving Operating Mode Switch to "OFF." Wait 1 minute and switch to "AUTO/REMOTE" or "CHARGE ONLY." If unit remains in shutdown mode after several attempts to reset, contact Tripp Lite Customer Service for assistance.
	Unit has shut down due to excessive battery discharge.	Use an auxiliary charger* to raise battery voltage. Check external battery connections and fuse. Unit automatically resets when condition is cleared.
	Unit has shut down due to overload.	Reduce load. Reset by moving Operating Mode Switch to "OFF." Wait 1 minute. Switch to "AUTO/REMOTE" or "CHARGE ONLY."
Battery Not Recharging (AC Input Present)	Connected batteries are dead.	Check and replace old batteries.
	Battery fuse* is blown.	Check and replace fuse.*
	Battery cabling* is loose.	Check and tighten or replace cabling.*
	Unit has shut down due to battery overcharge (preventing battery damage). The problem may be with connected auxiliary chargers, if any, or with the unit's charger.	Disconnect any auxiliary chargers. Reset by moving Operating Mode Switch to "OFF." Wait 1 minute and switch to "AUTO/REMOTE" or "CHARGE ONLY." If unit remains in shutdown mode after several attempts to reset, contact Tripp Lite Customer Service for assistance.
	Input circuit breaker is tripped.	Reset circuit breaker.
All Three Battery Indicator Lights Are Slowly Flashing (½ Second Flashes)	Battery is excessively discharged.	Use an auxiliary charger* to raise battery voltage. Check external battery connections and fuse. Unit automatically resets when condition is cleared.
All Three Battery Indicator Lights Are Rapidly Flashing (¼ Second Flashes)	Battery is overcharged. Unit will shut down to prevent battery damage. The problem may be with connected auxiliary chargers, if any, or with the unit's charger.	Disconnect any auxiliary chargers. Reset by moving Operating Mode Switch to "OFF." Wait 1 minute and switch to "AUTO/REMOTE" or "CHARGE ONLY." If unit remains in shutdown mode after several attempts to reset, contact Tripp Lite Customer Service for assistance.
Red "LOW" Battery Indicator Light is Flashing	Battery voltage is low. Unit will automatically shut down after 5 seconds to protect battery from damage.	Make sure that AC power is present in order to recharge batteries. Reset by moving Operating Mode Switch to "OFF" then to "AUTO/REMOTE" or "CHARGE ONLY."
	False reading due to undersized or insufficiently connected DC cabling.	Use sufficient size DC cable sufficiently connected to the Inverter/Charger.
Red "LOAD" Operation Indicator Light Flashing	Inverter is overloaded. Unit will automatically shut down after 5 seconds.	Reduce load. Reset by moving Operating Mode Switch to "OFF." Wait 1 minute. Switch to "AUTO/REMOTE" or "CHARGE ONLY."

* User-supplied.



1111 W. 35th Street, Chicago, IL 60609 USA
Customer Support: (773) 869-1212
www.tripplite.com

Free Manuals Download Website

<http://myh66.com>

<http://usermanuals.us>

<http://www.somanuals.com>

<http://www.4manuals.cc>

<http://www.manual-lib.com>

<http://www.404manual.com>

<http://www.luxmanual.com>

<http://aubethermostatmanual.com>

Golf course search by state

<http://golfingnear.com>

Email search by domain

<http://emailbydomain.com>

Auto manuals search

<http://auto.somanuals.com>

TV manuals search

<http://tv.somanuals.com>