

# EXERCISE CYCLE F 250 ELECTRONICS

GB	OWNER'S MANUAL	P. 2-5
D	BETRIEBSANLEITUNG	S. 6-9
F	MODE D'EMPLOI	P. 10-13
R	ИНСТРУКЦИЯ ПО ЭКСПЛУАТАЦИИ	C. 14-17
I	MANUALE D'USO	P. 18-21
S	BRUKSANVISNING	S. 22-25
FIN	KÄYTTÖOHJE	S. 26-29

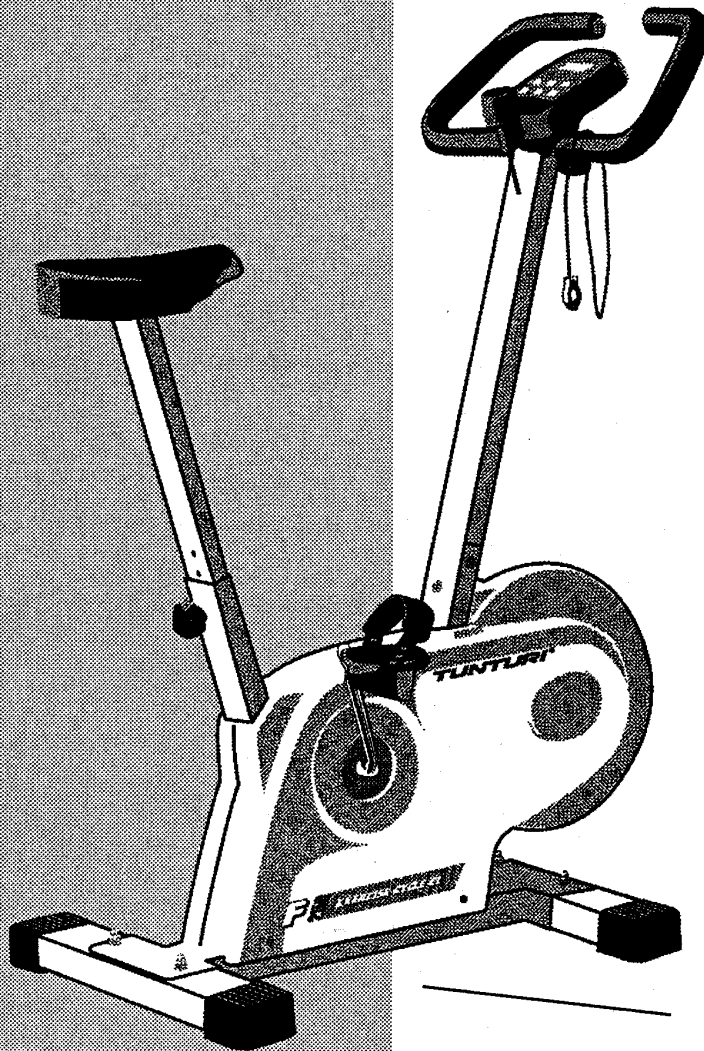

SERIAL NUMBER  
SERIENNUMMER  
NUMERO DE SERIE  
СЕРИЙНЫЙ НОМЕР  
NUMERO DI SERIE  
SERIENNUMMER  
SARJANUMERO

583.0003 B

**TUNTURI®**  
THE MOTOR – *it's you.*

Left, right, front and rear are seen from the exercising position. Assemble the cycle as follows:

## MOUNTING THE SUPPORT TUBES

Put the rear support tube in place. Secure the support tube with two lock screws, four washers and two dome nuts. Install the front support tube in the same way.

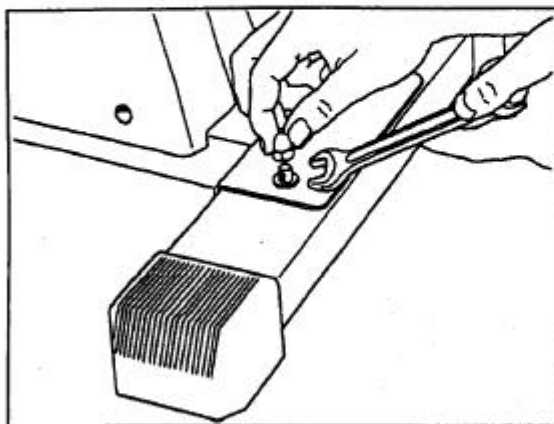

## MOUNTING THE HANDLEBAR SUPPORT TUBE

Connect the wire from the upper end of the frame tube to the wire at the lower end of the handlebar tube.

Open the plastic locking clasp and loosen the brake belt a little. Hold on to the free end of the belt so that it remains on the tight and on the flywheel. Connect the spring at the upper end of the brake belt, coming from the frame tube, to the lower end of the brake cable at the lower end of the handlebar support tube. Press the handlebar tube into position. **N.B. Be careful not to damage the wire.** Fasten the plastic locking clasp and secure the handlebar with three screws and washers.

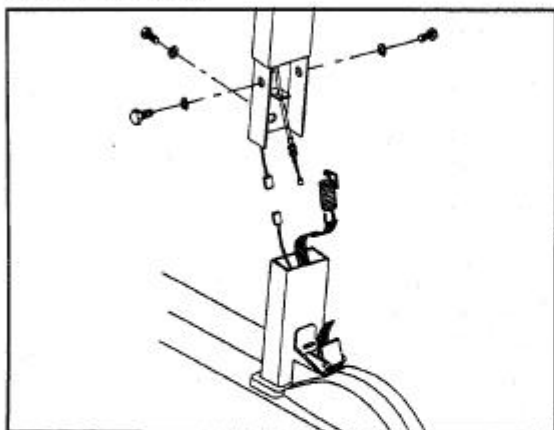

## MOUNTING THE HANDLEBAR AND THE METER

Fit the handlebar in its place at the top of the handlebar tube and fasten it with a lock screw and plastic lever (the lever is on the back of the meter).

Place the supplied batteries in the holder at the back of the meter. Connect the wire from the handlebar support tube to

the socket of the meter and push the meter into place. **N.B. Be careful not to damage the wire.** Install the resistance adjustment knob into place at the lower end of the meter by two screws.

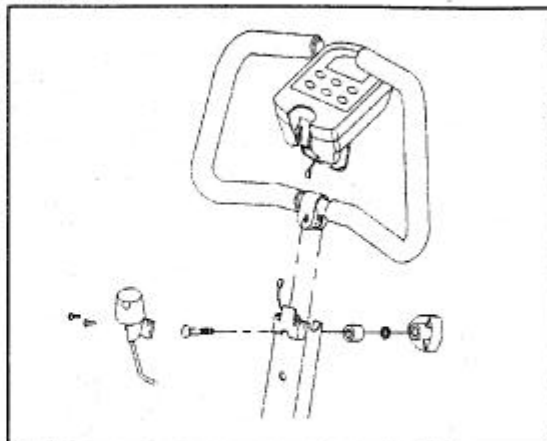

## ADJUSTING THE BRAKE BELT

Turn the resistance adjustment knob anticlockwise to its extreme position. Take hold on the free end of the brake belt and open the locking clasp. Pull the brake belt on the flywheel to appropriate tightness and fasten the belt with the plastic locking clasp.

**N.B.** Should the belt fall off the flywheel, it can be reinstalled by opening the side covers

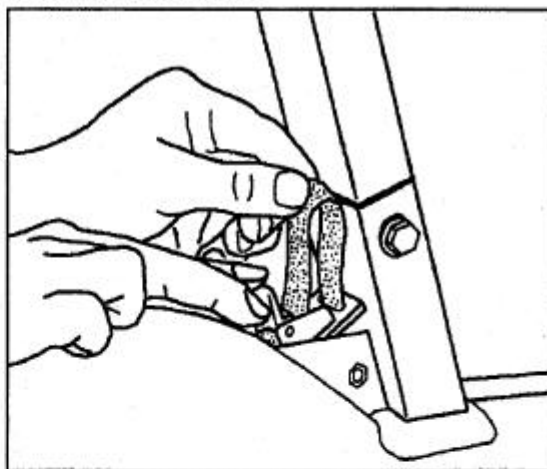

## MOUNTING THE PEDALS AND THE SEAT

Attach the right pedal to the right-hand crank by turning clockwise and the left pedal to the left-hand crank by turning counterclockwise. Use a fork wrench. The pedals are marked R for right and L for left.

The pedal straps are adjustable. Fasten the pedal straps so that the TUNTURI logo faces outward. Choose the strap tightness, set the appropriate strap hole on the retainer from below and pull forcibly upward. Especially when the cycle is new, the fastening of the strap may seem relatively tight.

Insert the seat tube into the frame tube and set it to the desired height by tightening the adjustment knob. Fasten the seat to the seat tube with the nuts provided.

## USE

### ADJUSTING SEAT HEIGHT

Set the seat height so that the middle part of the foot rests on the pedal with the leg almost straight and the pedal in the lowest position. The seat inclination can be adjusted to a certain extent by inserting spacers under the seat securing screws. **N.B.** Always make sure before using the cycle that the locking pin of the seat tube is properly tightened and in its hole.

### ADJUSTING THE HANDLEBAR

Loosen the handlebar adjusting knob and turn the handlebar until it feels comfortable for exercising. Remember to tighten the knob after adjustment.

### ADJUSTING PEDALLING RESISTANCE

Adjust resistance by turning the knob below the meter. To increase resistance, turn clockwise (+), to decrease resistance turn counterclockwise (-). If the resistance levels by such adjustment feel inadequate, it is also possible to adjust the brake belt (see ADJUST THE BRAKE BELT).

### EXERCISING

Working out using a fitness cycle is excellent aerobic exercise, the principle being that the exercise should be suitably light, but of long duration. Aerobic exercise is based on improving the body's maximum oxygen uptake, which in turn improves endurance and fitness. The ability of the body to burn fat as a fuel is directly dependent on its oxygen-uptake capacity.

Aerobic exercise should above all be pleasant. You should perspire, but you should not get out of breath during the workout. **Exercise at least three times a week, 30 minutes at a time, to reach a basic fitness level.** Maintaining this level requires a few exercise sessions each week. Once the basic condition has been reached, it is easily improved by increasing the number of exercise sessions.

Exercise is the only way of increasing the energy spent by the body. This is why it is worthwhile to combine regular, preferably daily exercise with a healthy diet. Start with 30 minutes or less at a time, and gradually increase the workout time to one hour.

Start slowly at a low pedalling speed and low resistance. For an overweight person, strenuous exercise may subject the heart and circulatory system to excessive strain. Exercise efficiency can be measured by the pulse. The TUNTURI F 250's pulse meter helps you monitor your pulse easily during exercise, and thus to ensure that the exercise is sufficiently effective but not over-strenuous (see MEASURING PULSE).

## METER

**N.B.** Protect the meter from direct sunlight, as it may damage the liquid crystal display. Protect the meter from water and avoid severe impacts, as these may also damage the meter.

The TUNTURI F 250's easy-to-use meter measures time, pulse, distance, energy consumption and speed. The meter switches on automatically when you start pedalling or press any key on the meter, and switches off when you have not pedalled or pressed a key for about 4 minutes.

### REPLACING BATTERIES

If the meter display fades considerably or disappears completely, replace the batteries. Detach the lid of the battery casing from the back of the meter. Replace the used batteries with new ones (1.5 V AA), following the + and - signs on the bottom of the case. Push the meter back into place.

### KEYS AND FUNCTIONS

The meter display shows the selected function. For example, if you want to monitor pedalling speed during your workout, press the SPEED key, etc. When the meter first switches on, the display shows time.

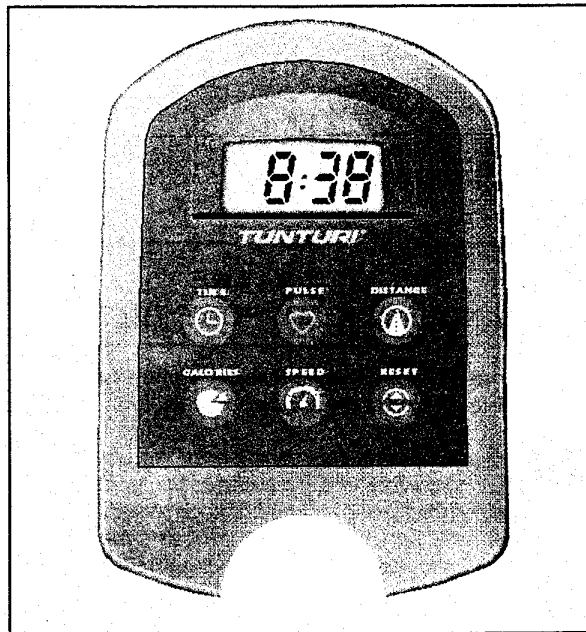

### TIME

Shows time counted upwards in minutes and seconds (00:00-59:59 by the second, then 1:00-99:59 by the minute; the colon flashes on the display once per second).

### PULSE

Shows pulse frequency per minute (40-240 beats/min). The heart symbol beside the pulse value flashes in time with the user's heartbeat (see MEASURING PULSE).

### DISTANCE

Shows cumulatively distance in kilometres (0.00-999 km; 0-9.99 km in 0.01 km steps, 10.0-99.9 km in 0.1 km steps, and 100-999 km in 1 km steps) or miles (0.00-999 miles; 0-9.99 miles in 0.01 mile steps, 10.0-99.9 miles in 0.1 mile steps, and 100-999 miles in 1 mile steps). The preset setting on the meter is km (see SELECTING SPEED AND UNIT OF DISTANCE).

### CALORIES

Shows estimated calorie consumption in kilocalories (0-999 kcal) during workout. In theory, energy consumption is calculated from pedalling resistance, speed and distance pedalled, but because different people's capacity to produce energy (efficiency) varies, the energy consumption display shows only an approximation of the real consumption. This meter calculates the energy consumption on the basis of average values.

**SPEED**

Shows your pedalling speed in kilometres per hour (0.0-99.9 km/h), miles per hour (0.0-99.9 mph) or pedalling revolutions per minute (0-999 rpm). The default setting on the meter is km/h (see **SELECTING SPEED AND UNIT OF DISTANCE**)

**RESET**

The readings (time, distance, energy consumption) that have accumulated during your workout are reset automatically when the meter is switched off. You can also reset the readings by pressing the **RESET** key.

**SELECTING SPEED AND UNIT OF DISTANCE**

You can select the unit on the meter by the switch on the bottom of the battery casing. Open the lid of the battery casing at the back of the meter housing. There are two switches - one for selecting either kilometres or miles as the unit of distance, and the other for selecting either rpm, km/h or mph. Select the unit on the switch and push the lid of the battery casing back into place.

**MEASURING PULSE**

Measure the pulse as follows:

1. Fit the sensor wire plug into the connecting point on the bottom of the meter.
2. Attach the ear sensor to the earlobe, where pulse is to be measured (A).
3. Attach the sensor wire e.g. to the collar with the clip provided. This will prevent moving of the sensor and insure a more accurate reading of the pulse (B).

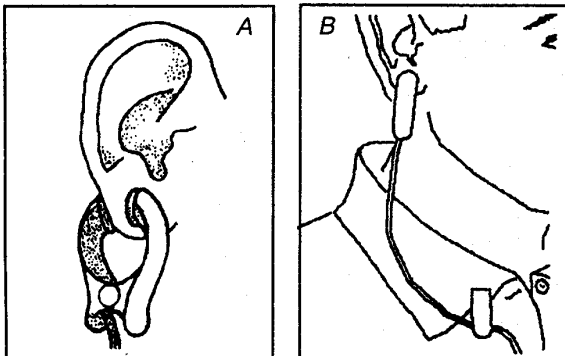

4. Press the **PULSE** key on the meter and the display will start to show your pulse. The heart symbol beside the pulse value flashes in time with the user's heartbeat.

Exercise of long duration within a pulse range that is about 50-60% of the maximum pulse burns effectively fat, i.e. helps you lose weight. Exercise in a range that is about 70-80% of the maximum develops the heart and respiratory system, and overall endurance, i.e. it improves your condition.

If you don't know your own maximum pulse rate you can use the following formulae as a guideline:

**WOMEN: 226 - AGE, MEN: 220 - AGE**

However, it is advisable to make sure by consulting your doctor.

For example, to lose weight, a 50-year-old man should exercise at a resistance and pedalling speed that raise his pulse to about 85-105 beats/min.

**NOTE WHEN MEASURING YOUR PULSE...**

If measuring disturbances appear while pedalling, **test the functioning of the sensor while stationary**. Strong, unintentional swaying while pedalling may also disturb measurement. If pulse values rise above 150 beats/min., earlobe measurement may be affected by the speeding up of circulation.

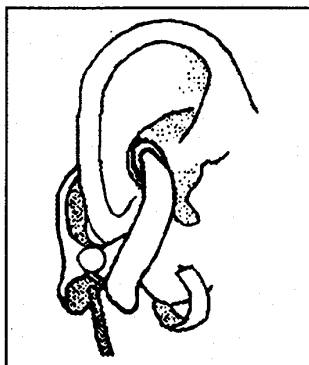

Physiological differences between different people may also cause disturbances in pulse measurement. If the circulation is poor in the earlobe, the earlobe is too small or cartilaginous as a result of piercing, try measuring on the tip of your finger or on the inside surface of the ear which is possible with ear sensor designed by TUNTURI.

If the sensor does not immediately start measuring your pulse, or if the earlobe is cold, **rub the earlobe with the fingers to speed up circulation**.

Sometimes a **strong light source**, e.g. a fluorescent tube, in the immediate vicinity of the user may cause disturbances in pulse measurement. In this case, **test the functioning of the sensor by turning the ear sensor the other way round on the earlobe**. Pulse reading can also be affected, if the battery power of the meter is too low.

**Remember to clean the ear sensor.** Clean the ear sensor after use, for example, with mild soapy water. Do not use solvents.

**MAINTENANCE AND STORAGE**

The F250 requires very little maintenance. Check, however, from time to time that all fastening screws and nuts are tight. Clean the cycle with a damp cloth. Do not use solvents.

If the cycle is not functioning properly during use, contact your TUNTURI dealer immediately.

In spite of continuous quality control, individual defects and malfunctions may occur in individual components. It is in most cases unnecessary to take the whole cycle for repair, as it is usually sufficient to replace the defective part.

To prevent malfunctioning of the cycle, store in a dry place with as little temperature variation as possible, protected from dust.

**DIMENSIONS**

Length	89 cm	Width	50 cm
Height	114 cm	Weight	26 kg

All TUNTURI models are designed to meet the electromagnetic compatibility directive, EMC and are affixed with the CE conformity marking.

**Due to our continuous policy of product development we reserve the right to change specifications without notice.**

**List for Recycling /  
Index für Materialentsorgung**

A = Plastic, thermoplast /  
Kunststoff, Thermoplast  
B = Paper, Carton /  
Papier, Pappe  
C = Metal / Metall  
D = Electronics / Elektronik  
E = Batteries / Batterien  
F = Other / Sonstiges

This list will help you to sort out  
the different components for  
recycling purposes.  
Dieser Index soll Ihnen die  
Zuordnung der Rohstoffe bei  
einer späteren Entsorgung  
erleichtern.

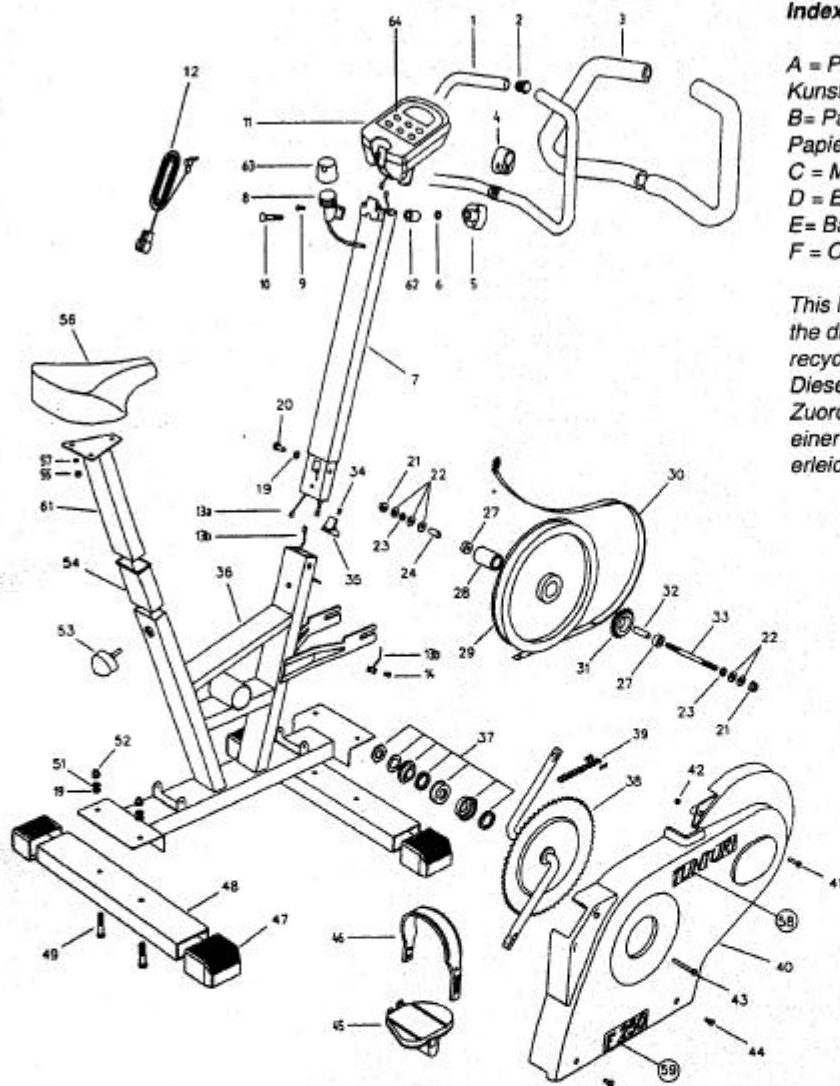

**Ref. no Part no.**

1	203 0001 (incl. 2,3)	C	29	303 0002	C	48	103 0004	C
2	533 0010	A		(incl. 21-24,27,28,31-33)		49*	653 0029	C
3	213 0001 (incl.2)	A	30	443 0004	F	51*	63 08 127B	C
4	513 0001	C	31	263 100 88	C	52*	61 0821	C
5*	653 0060	A	34	653 0024	C	53	653 0061	A
6*	653 0067	C	35	503 0008	A	54	533 0012	C
7	203 0006	C	36	103 0003	C	55*	61 0610	C
8	373 0008	A	37	353 0008	C	56	153 0003	A
9	653 0017	C	38	353 0007	C	57*	62 0612 16	C
10	653 0018	C	39	253 0001	C	59	423 0039 (incl. 58)	F
11	233 0024	D	40	173 0009 (R)	A	61	153 0004	C
12	233 0022	A	-	173 0010 (L)	A	62*	523 0010	C
13	403 0016 (incl. 13a, 13b)	D	41	653 0025	C	63	533 1014	A
14	653 0034	C	42	61 05 01	C	64	423 0065	F
19*	653 0016	C	43	653 0027	C	-	5530010 Hard ware kit	F
20*	60 08 016 03	C	44	653 0028	C		(incl. *)	
-	333 0003	C	45	363 1001 (incl. 46)	A	-	583 0003 Owner's manual B	
	(incl. 21-24, 27,32,33)	C	46	363 1002	A			
28	333 0002	C	47	533 0011	A			



## Free Manuals Download Website

<http://myh66.com>

<http://usermanuals.us>

<http://www.somanuals.com>

<http://www.4manuals.cc>

<http://www.manual-lib.com>

<http://www.404manual.com>

<http://www.luxmanual.com>

<http://aubethermostatmanual.com>

Golf course search by state

<http://golfingnear.com>

Email search by domain

<http://emailbydomain.com>

Auto manuals search

<http://auto.somanuals.com>

TV manuals search

<http://tv.somanuals.com>