



Échelon™ Series



Installation Guide

CO2075DWR — Combo Drawer Model Ice Maker/Refrigerator

www.U-LineService.com

Phone (414) 354-0300 • FAX (414) 354-7905
Service & Parts Tech Lines Phone (800) 779-2547 • FAX (414) 354-5696
OnlineService@U-Line.com

©2005 U-Line Corporation
02/2005

Contents

Exterior Cleaning 4
 Cut-Out Dimensions 4
 Product Dimensions 5
 Clearances Information 5
 Other Site Requirements 6
 No Custom Drawer Panels 7
 Custom 1/4" Drawer Panel Inserts 7
 Full Overlay Drawer Panels 8
 Checking Drawer Alignment 9
 Adjusting Drawer Alignment 10
 Water Supply Connection 12
 Electrical Specifications 13
 Leveling Information 13
 Installation Tip 13
 Installation of the CO2075DWR 14
 Anti-Tip Kit Installation 14
 Installation Troubleshooting 15
 Initial Start-Up 15
 Start-Up Troubleshooting 16
 Service Information 17

1 Follow Safety Precautions

IMPORTANT

PLEASE READ all instructions completely before attempting to install or operate the unit.

- This unit requires connection to the water supply. Improper hook-up can result in substantial property damage! If you are unsure of your ability to safely connect the water supply to the unit, consult a licensed plumber for assistance.
- This unit requires connection to a grounded (three-prong), polarized receptacle that has been placed by a qualified electrician in accordance with applicable electrical codes.

Safety Alert Definitions

Safety items throughout this guide are labeled with a Danger, Warning or Caution based on the risk type:

⚠ DANGER

Danger means that failure to follow this safety statement will result in severe personal injury or death.

⚠ WARNING

Warning means that failure to follow this safety statement could result in serious personal injury, or death.

⚠ CAUTION

Caution means that failure to follow this safety statement may result in minor or moderate personal injury, property or equipment damage.

General Precautions

Use this appliance for its intended purpose only and follow these general precautions along with those listed throughout this guide:

WARNING

SHOCK HAZARD — Electrical Grounding Required.

- **Keep the unit unplugged throughout installation except during testing.**
- **Never remove the round grounding prong from the plug and never use a two-prong grounding adapter.**
- **Never use an extension cord to connect power to the unit.**
- **Always keep your working area dry.**

WARNING

The Anti-Tip Kit must be installed on this unit before it is used. Never use the drawers as steps or as a shelf to support more than the drawers' contents. Serious personal injury could occur.

CAUTION

- Use care when moving and handling the unit. Use gloves to prevent personal injury from sharp edges.
- Do not lift the unit by the drawer handle.
- Do not install the unit behind closed doors or in any way that would obstruct airflow to the front grille, which may cause the unit to malfunction.

2 Inspect and Plan

You have received a carton containing your CO2075DWR Combo Drawer Model Ice Maker/Refrigerator with a package inside containing a User Manual, a Product Registration Card, water connection parts and Anti-Tip Kit. Complete and mail the Product Registration Card or register online at www.U-LineService.com. Once your unit is installed, keep the User Manual and this Installation Guide in a safe place for future reference.

Your unit is Black or Stainless Steel. Black units have drawers with top handles designed for the installation of full overlay drawer panels. When full overlay panels will not be used, replacement handles **MUST** be installed (part number 11926-4-BLK). Stainless Steel units have drawers with seamless full wrap stainless steel fronts (that do not accept custom panels), sculpted stainless steel handles and black vinyl-clad cabinets. Please carefully follow the directions that apply to your unit and your intended design.

Tools/Materials Required

- Wrenches
- Screwdrivers — slotted and Phillips head
- 1/4-inch OD copper tubing and shut-off valve for water supply line
- 1/4-inch thick drawer panel material and cutting tools (Black units)
- 3/4-inch thick drawer panel overlay material, cutting tools, drill and bits (Black units)

Inspection

Unwrap and inspect the unit on a flat, level surface capable of supporting its entire weight.

Removing Protective Coating

All Models:

The protective coating covering the inside of the top drawer must be removed before using.

Stainless Steel Models:

When inspecting/installing a Stainless Steel unit, the protective coating covering the drawer fronts must be removed. Start at a corner of the drawers and pull back the protective coating to remove it from the drawer fronts.

After all the protective coating has been removed from the drawers, clean all Stainless Steel surfaces with Claire Stainless Steel Polish and Cleaner or comparable product or a mild detergent and warm water solution and soft cloth. Do **NOT** use abrasive cleaning agents.

Note: If cleaning with mild detergent and warm water solution and soft cloth, the unit **MUST** be treated with Claire Stainless Steel Polish and Cleaner or comparable product to prevent discoloration.

Exterior Cleaning

(As Required)

Black Models:

- The drawers, grille and cabinet may be cleaned with a mild detergent and warm water solution. Do not use solvent-based or abrasive cleaners. Use a soft sponge and rinse with clean water. Wipe with a soft, clean towel to prevent water spotting.

Stainless Steel Models:

- Stainless steel models can discolor when exposed to chlorine gas, pool chemicals, salt water or cleaners with bleach.
- Keep your stainless steel unit looking new by cleaning with a good quality all-in-one stainless steel cleaner/polish on a monthly basis. For best results use Claire Stainless Steel Polish and Cleaner, which can be purchased from U-Line Corporation. (The part number is 173348.) Comparable products are acceptable. Frequent cleaning will remove surface contamination that could lead to rust. Some installations may require cleaning on a weekly basis.
- **Do not clean with steel wool pads.**
- **Do not use cleaners that are not specifically intended for stainless steel (this includes glass, tile and counter cleaners).**
- If any surface discolors or rusting appears, clean it quickly with Bon-Ami or Barkeepers Friend Cleanser and a non-abrasive cloth. Always clean in the direction of the grain. Always finish this process with Claire Stainless Steel Polish and Cleaner or comparable product to prevent further problems.
- **Use of abrasive pads such as Scotchbrite will cause the graining in the stainless to become blurred.**
- Rust that is allowed to linger can penetrate into the surface of the stainless steel and complete removal of the rust may not be possible.

3 Prepare Site

Your U-Line product has been designed for built-in installation. Your unit does not require additional air space for top, sides or rear. However, the front grille must NOT be obstructed and clearance is required for water and electrical connections in the rear.

Note: Unit can NOT be installed behind a closed cabinet door.

Cut-Out Dimensions

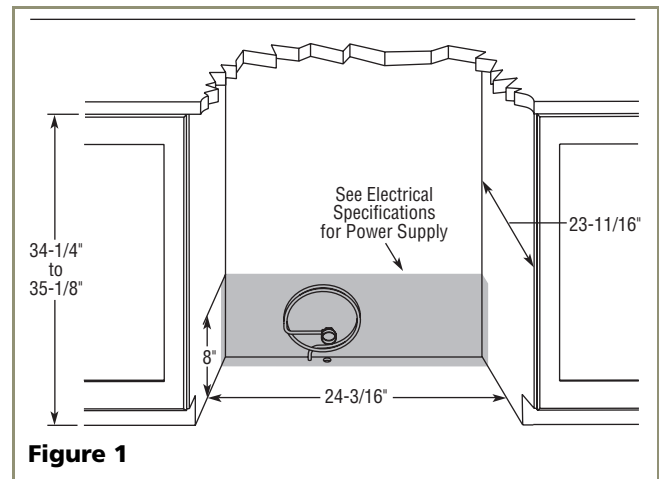
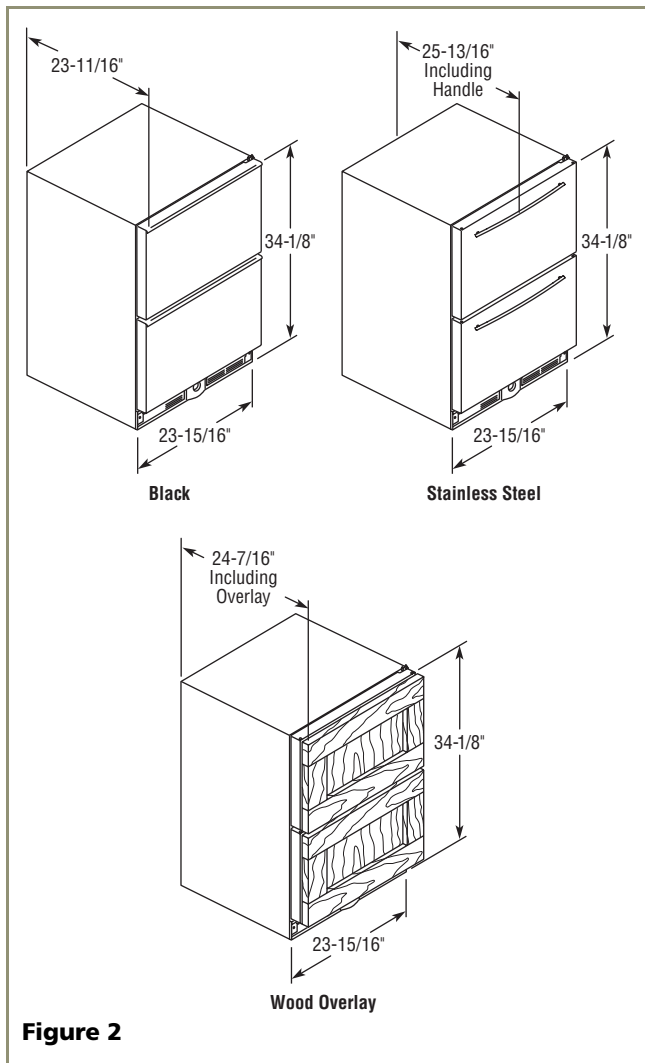

Figure 1

Follow the cut-out drawing in **Figure 1**. The 24-3/16" width allows 1/4" for ease in installation and removal of the unit. 24" is the counter depth in most installations. The unit is 23-11/16" deep including the drawer and not the full handle or 3/4" overlay (see **Figure 2**).

Product Dimensions



Please note that the unit has adjustable feet that can add one additional inch to height during leveling or to match adjacent cabinets (see **Figure 28** on **Page 13**).

Clearances Information

The unit must be installed in a wall or under a countertop to allow for the installation of the Anti-Tip Kit (see **Page 14**).

⚠ WARNING

The Anti-Tip Kit must be installed on this unit before it is used. Never use the drawers as steps or as a shelf to support more than the drawers' contents. Serious personal injury could occur.

The unit is designed so it can be installed next to a wall on either side (see **Figure 3**).

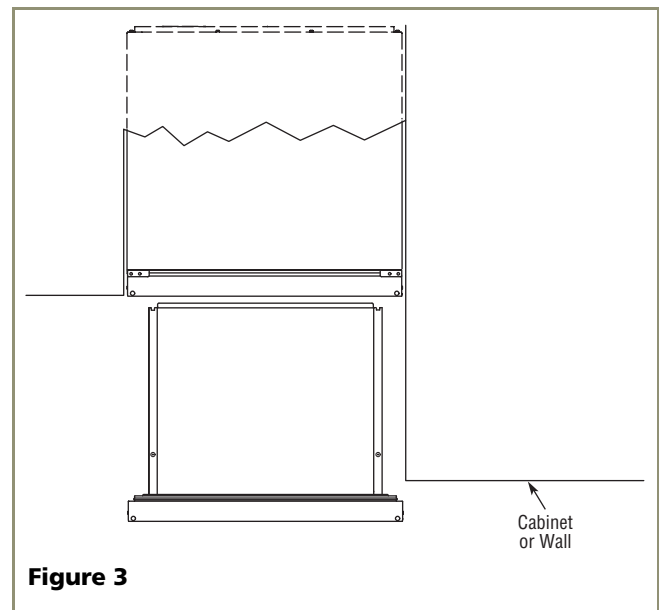

The drawer unit can be installed with an appliance or fixture located in front of it, as long as there is adequate clearance for the drawer to be opened and removed when servicing (see **Figure 4**).

Note: U-Line recommends you consider additional clearance in front of the open drawer for convenience.

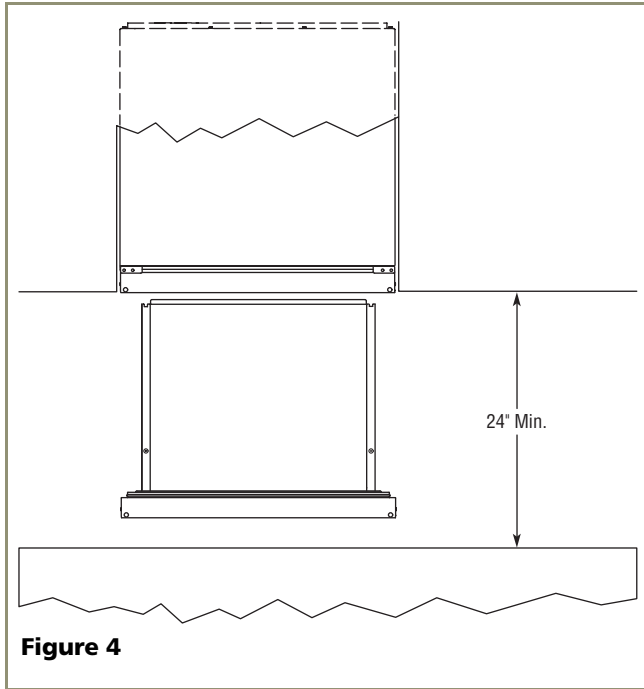

Other Site Requirements

Power Supply

The unit requires a grounded and polarized 115 VAC, 60 Hz, 15A circuit (normal household current). See *Electrical Specifications* on **Page 13**.

Water Supply

The unit requires a 1/4-inch OD water supply line and a shut-off valve. For more information see **Page 12**.

Environmental Requirements

The surrounding air temperature must be at least 50°F (10°C) but must not exceed 110°F (40°C). High ambient temperature ranges and warmer water supply will cause reduced ice production. Units may be installed outdoors in a covered area. The unit must not be located near heat-generating equipment or in direct sunlight.

4 Prepare and Install Drawer Panel

(Black Units Only)

Two types of custom drawer panels can be installed on your Black unit to harmonize with or accent the surrounding décor: Custom 1/4" Inserts or Full Overlays. Black units may also be installed with no custom drawer panel.

No Custom Drawer Panels

When full overlay drawer panels are not used, replacement handles (part number 11926-4-BLK) must be installed on each drawer. To replace the handle when no custom panel will be installed, follow the instructions under Custom 1/4" Drawer Panel Inserts, Door Panel Installation below, disregarding Steps 4 and 5.

Custom 1/4" Drawer Panel Inserts

Drawer Panel Preparation

Custom drawer panels can be inserted into the drawer fronts. Custom drawer panels can be flat or raised, as long as the maximum panel thickness where inserted into the drawer front reveal (channel) is 1/4"-thick. For raised panels, the depth of the reveal is 1/4" on all four sides.

IMPORTANT

Raised panels will reduce the drawer's front clearance if the unit is installed facing an appliance or structure (see **Page 5**).

Cut the panel inserts to the following dimensions.

Custom 1/4" Dimensions:

Width: 23-1/32"
Height: 12-15/16"

The door panels must not have a total weight of more than 20 lbs.

Drawer Panel Installation

Install the insert as follows:

CAUTION

Use care when handling the insert. Insert edges may be sharp.

1. Open drawer. Pull drawer gasket out of groove (top edge of drawer only). Start in the middle and pull outward, moving toward the edge (see **Figure 5**). This may take some force.
2. Remove the three screws behind the gasket and save. Carefully pull the top handle up and off and discard.

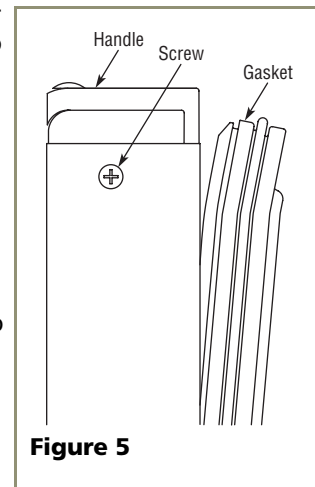

Figure 5

3. Remove and save the two outside screws and the lower handle (see **Figure 6**).
4. Remove and discard existing panel and cardboard spacer.
5. Slide custom drawer panel insert into 1/4-inch channel in drawer front.
6. Attach the full handle to the lower handle using the three screws removed in Step 2.
7. Holding drawer gasket out of the way, replace handle on drawer, making sure it is seated properly on insert and that screw holes line up.
8. Install two small screws removed in Step 3.
9. Starting at the corners and working inward, push drawer gasket into place on drawer. Go on to **5 Adjust Drawers**.

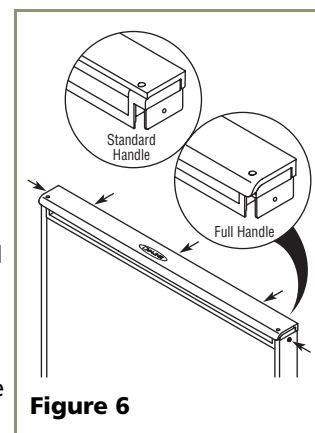

Figure 6

Full Overlay Drawer Panels

Drawer Panel Preparation

Full overlay drawer panels completely cover the drawer fronts and handles to give a built-in appearance. Black units are shipped ready for full overlay installation.

Note: For standard installations, both drawers mount the same and a 1/2" gap is achieved between drawers.

1. Cut the overlay to the following dimensions.

Full Overlay Dimensions:

Width: 23-3/4"

Height: 14-3/4"

IMPORTANT

The thickness of the wood overlay panel must be 3/4". The door panel must not weigh more than 20 lbs.

Drawer Panel Installation

Removing Existing Drawer Fronts

1. Open drawer. Pull drawer gasket out of groove (top edge of drawer only). Start in the middle and pull outward, moving toward the edge (see **Figure 7**). This may take some force.
2. Remove and save the two screws located at the ends of the handle (see **Figure 8**). Remove the handle.

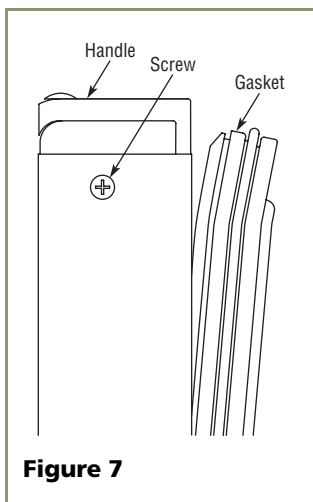

Figure 7

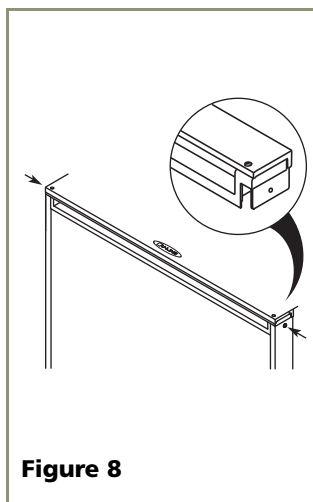

Figure 8

3. Remove existing panel and cardboard spacer. Discard the spacer.

Attaching the Full Overlay Panel

1. If user-supplied cabinet handles will be used, attach their hardware to the overlay panel at this time.

IMPORTANT

User-supplied cabinet handles **MUST** be counter bored to make sure mounting hardware is below surface of overlay panel. Failure to do so can cause damage to overlay panel and/or drawer. Overlay panel will not sit flush to drawer if mounting hardware is not counter bored.

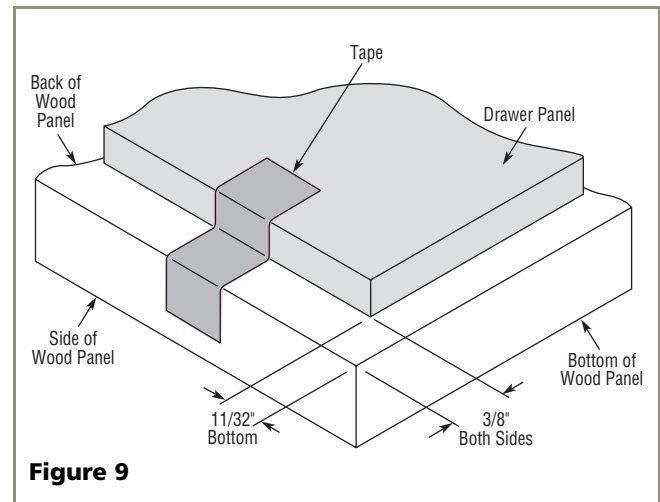

Figure 9

2. Place and tape the existing drawer panel on the back of the overlay panel (see **Figure 9**).
3. Drill the five holes (5/32" drill 3/8" deep) through both panels according to **Figure 10**.

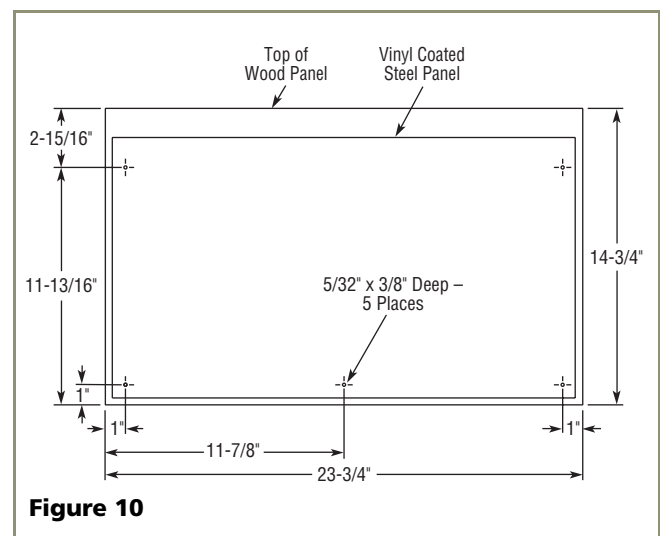
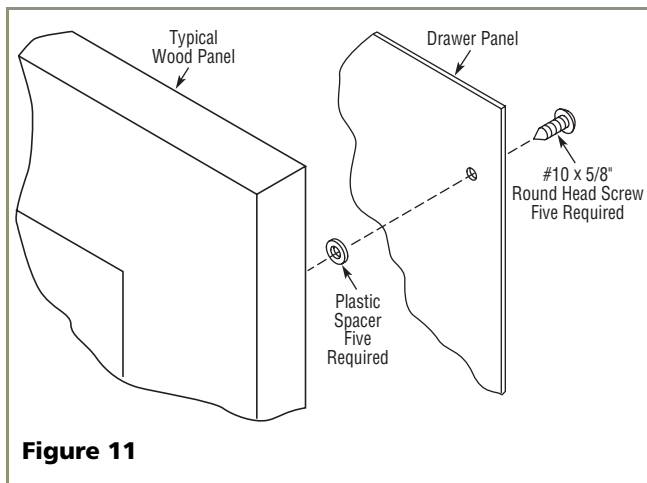

Figure 10

⚠ CAUTION

It is important to ensure that all drilled holes are drilled to the correct depth in order to avoid splits in the wood when hardware is installed.

- Remove tape adjoining the panels and enlarge the five holes in the overlay panel using a 0.201" (#7) drill.
- Attach the drawer panel to the overlay panel using #10 x 5/8" wood screws and nylon spacers. The nylon spacers fit between the overlay panel and the door panel as shown in **Figure 11**. The spacers allow the original drawer panel to slide back into the 1/4"-thick drawer front reveal (channel).



IMPORTANT

Drawer panel and overlay panel must be aligned properly or the drawer will not operate correctly.

Assembling the Drawer Front

- Install the assembled panel by sliding the original door panel back into the drawer front.
- Replace the handle assembly and secure with the two screws removed in Step 2 under *Removing Existing Drawer Fronts*.
- Starting at the corners and working toward the center, push the drawer gasket back into place. Go on to **5 Adjust Drawers**.

5 Adjust Drawers

Checking Drawer Alignment

The unit's drawers are aligned at the factory before shipment. However, their alignment could have been disturbed during shipment or during overlay panel installation.

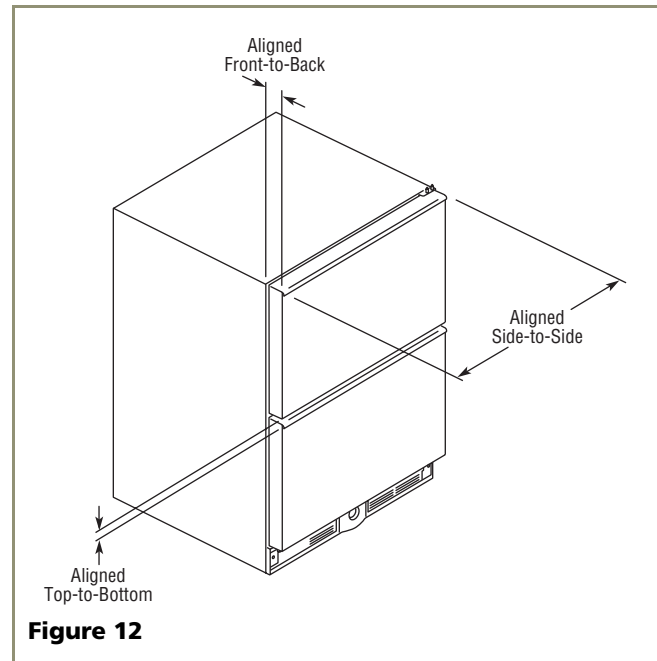

See **Figure 12**. Check each drawer to confirm that it is aligned:

- **Side-to-Side** — When viewed from the top, the drawer front should be square with the sides of the cabinet.
- **Front-to-Back** — When viewed from the side, the drawer front should be straight with the cabinet's sides, not cocked forward or back.
- **Top-to-Bottom** — When viewed from the front, the drawer should be level horizontally.

If both drawers are properly aligned, go on to **6 Prepare Plumbing**. If either drawer is not aligned, carefully follow instructions to remove that drawer, make the necessary adjustment and re-install the drawer.

Adjusting Drawer Alignment

WARNING

SHOCK HAZARD — The unit must be unplugged from the wall outlet during drawer removal, adjustment and re-installation.

Drawer Removal

1. Confirm that the unit is unplugged from wall outlet.
2. Unplug the drawer's connection wiring (top drawer only).
3. Remove the mounting screws. See **Figure 13**.
4. Pull the drawer completely out of the unit.

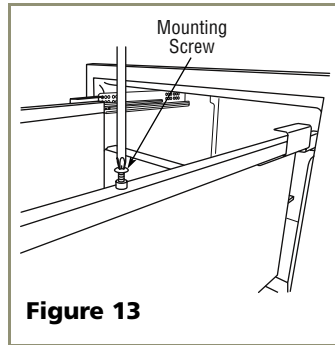

Figure 13

CAUTION

Use care when handling the drawer. Drawer edges, drawer rail and the unit's slide may be sharp.

IMPORTANT

Drawer adjustments are made by moving the slide that carries the drawer's rail. Minor adjustments may be made by loosening one of the slide's mounting screws, adjusting the slide and retightening the screw. Severe adjustments may be made by removing the slides' mounting screws, drilling new mounting holes and remounting the slide.

Side-to-Side Adjustment

See **Figure 14**. The drawer will need a Side-to-Side Adjustment if, when viewed from the top, the drawer front is not square with the sides of the cabinet. This is caused by one of the slides being mounted too far forward on the unit's liner.

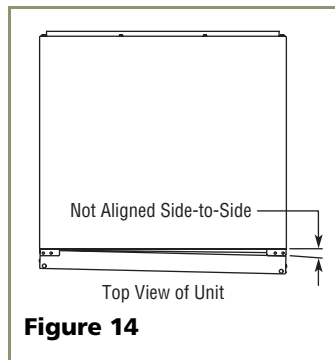

Figure 14

Minor Adjustment:

Note: The mounting holes on the slide are slightly larger than the screws' diameter.

1. Loosen the slide's mounting screws.
2. Push the slide backward.
3. Retighten the screws. See **Figure 15**.

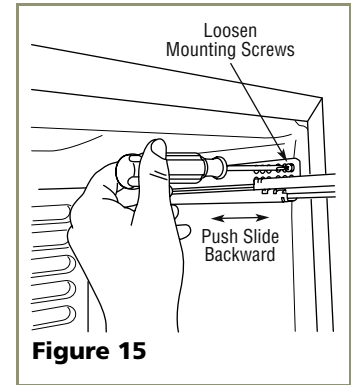

Figure 15

Severe Adjustment:

Note: The slides have extra mounting holes that may be used.

1. Remove the slide's mounting screws.
2. Reposition the slide so it is the same distance from the front of the liner as the other slide. Measure to confirm.
3. Mark new drilling holes using different sets of mounting holes on the slide. See **Figure 16**.

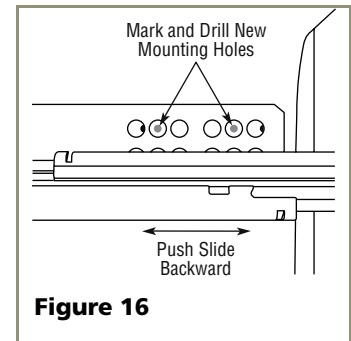

Figure 16

Note: Front location holes are shown. Corresponding rear holes will also need to be marked.

4. Drill all the new holes with a #30 drill bit.
5. Remount the slide.

Front-to-Back Adjustment

See **Figure 17**. The drawer will need a Front-to-Back Adjustment if, when viewed from the side, the drawer front is cocked forward or back. This is caused by the front slide mountings not being level with the rear slide mountings.

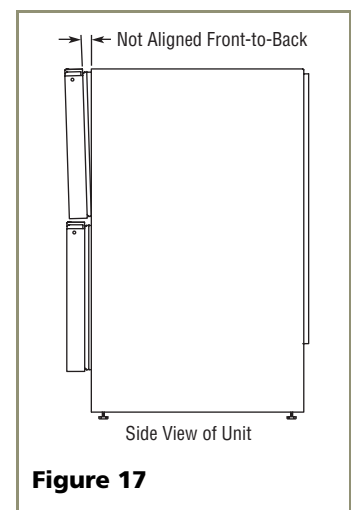

Figure 17

Minor Adjustment:

Note: The mounting holes on the slide are slightly larger than the screws' diameter.

1. Loosen one slide's mounting screws.
2. Level the slide.
3. Retighten the screws. See **Figure 18**.
4. Repeat procedure for the other slide.

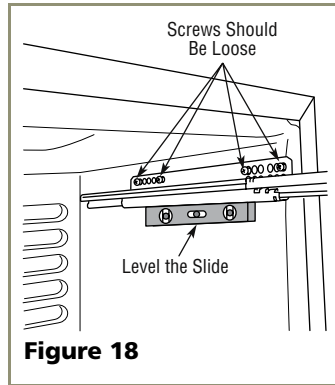

Figure 18

Severe Adjustment:

Note: The slides have extra mounting holes that may be used.

1. Loosen one slide's rear mounting screws.
2. Remove the slide's front mounting screws.
3. Reposition the slide so it is level.
4. Mark new front drilling holes using a different set of mounting holes on the slide. See **Figure 19**.
5. Drill the new holes with a #30 drill bit.
6. Remount the slide.
7. Repeat procedure for the other slide.

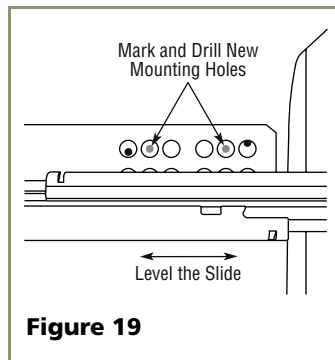

Figure 19

Top-to-Bottom (and Left-to-Right) Adjustment

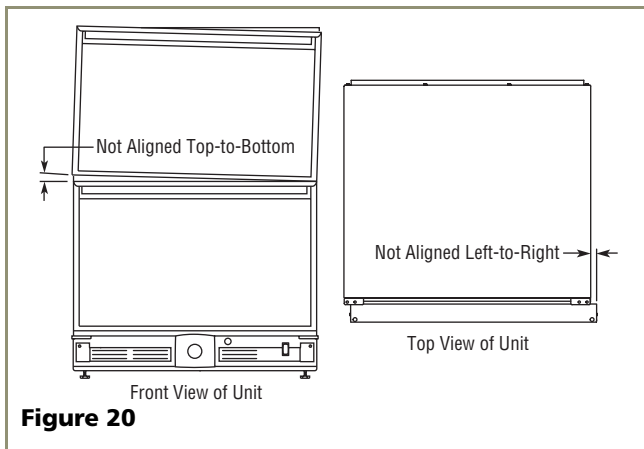

Figure 20

See **Figure 20**. The drawer will need a Top-to-Bottom Adjustment if, when viewed from the front, the drawer is not level horizontally. Viewed from the top, one side will protrude. This is caused by one of the slides being mounted higher than the other slide on the unit's liner.

Minor Adjustment:

Note: The mounting holes on the slide are slightly larger than the screws' diameter.

1. Loosen one slide's mounting screws.
2. Push the slide upward or downward to match the position of the other slide.
3. Retighten the screws. See **Figure 21**.
4. Repeat the procedure with the other slide if necessary.

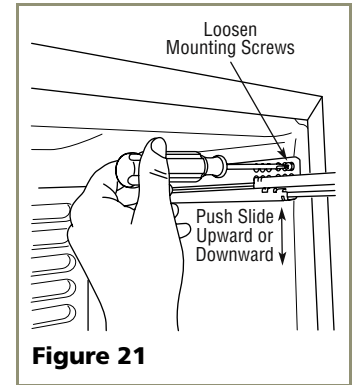

Figure 21

Severe Adjustment:

Note: The slides have extra mounting holes that may be used.

1. Remove one slide's mounting screws.
2. Reposition the slide so it is the same distance from the bottom of the liner as the other slide. Measure to confirm.
3. Mark new drilling holes using different sets of mounting holes on the slide. See **Figure 22**.

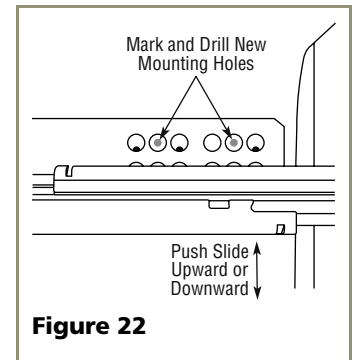

Figure 22

Note: Front location holes are shown. Corresponding rear holes will also need to be marked.

4. Drill all the new holes with a #30 drill bit.
5. Remount the slide.

Re-installation of Drawer

CAUTION

Use care when handling the drawer. Drawer edges, drawer rail and the unit's slide may be sharp.

1. Set the drawer's rails onto the slides.
2. Re-install the rails' mounting screws. See **Figure 13** on **Page 10**.
3. Plug in the drawer's connection wiring (top drawer only).
4. Go on to **6 Prepare Plumbing**.

6 Prepare Plumbing

Plumbing installation must observe all state and local codes. All water connections **MUST BE** made by a licensed/qualified plumbing contractor. Failure to follow recommendations and instructions may result in damage and/or harm.

WARNING

To prevent accidental electrocution, make certain that the floor surfaces surrounding the unit are dry whenever power is removed from, or applied to, the unit.

Water Supply Connection

When connecting the water supply, follow these guidelines:

- Review the local plumbing codes before you install the unit.
- Connect to the cold water supply.
- The water pressure should be between 20 and 120 psi.
- Install a shut-off valve in the 1/4 inch OD water supply line.
- Connect sufficient tubing to the unit so that tubing may be looped, allowing the unit to be removed for cleaning and servicing (see **Figure 25**). However, make certain that the tubing is not pinched or damaged during installation.
- U-Line recommends the use of copper tubing for installation.

To connect to water supply:

1. Install the 1/4 inch OD copper water line from the main water source (see **Figure 23**).

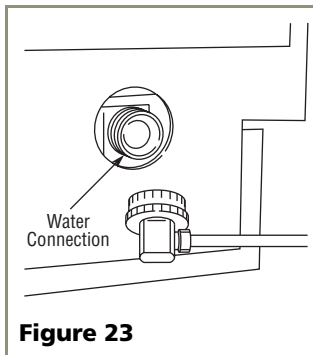

2. Locate the compression fitting and ferrule packed with the unit. Slide the compression fitting and ferrule over the 1/4-inch OD water supply line. Do not use thread sealing compound or tape. Using two wrenches, tighten the compression fitting on the supply line (see **Figure 24**).
3. Carefully bend the water supply line into position and connect the line to the solenoid valve (see **Figure 25**). Avoid kinking the water supply line.

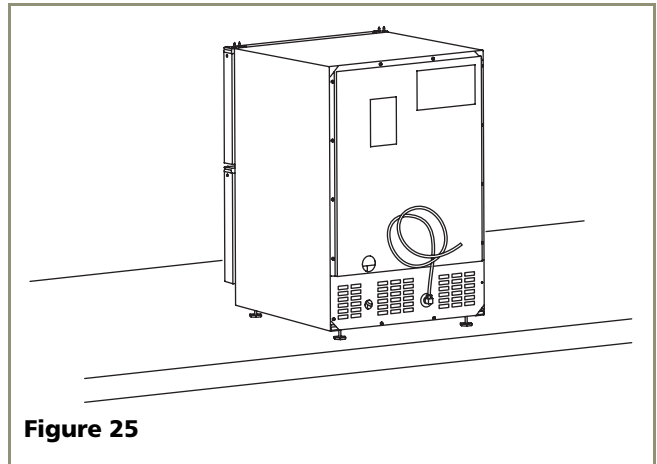

IMPORTANT

Normal operation creates some vibration. A water supply line contacting cabinet wall may cause excessive noise during operation or damage to the line.

4. Allow extra water supply line length to provide slack for easy removal from the recessed area (see **Figure 25**). This will also safeguard against kinking the line.
5. Go on to **7 Prepare Power Supply**.

7 Prepare Power Supply

Electrical Specifications

⚠ CAUTION

Electrical installation must observe all state and local codes. This unit requires connection to a grounded (three-prong), polarized receptacle that has been placed by a qualified electrician.

The unit requires a grounded and polarized 115 VAC, 60 Hz, 15A power supply (normal household current). An individual, properly grounded branch circuit or circuit breaker is recommended. GFCI (ground fault circuit interrupter) is usually not required for fixed location appliances and is not recommended for your unit because a GFCI could be prone to nuisance tripping. However, be sure to consult your local codes.

See **Figure 26** for recommended receptacle location.

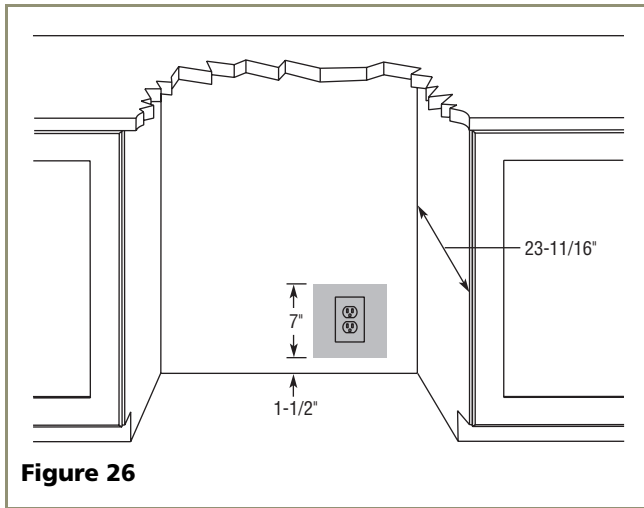

Figure 26

⚠ WARNING

SHOCK HAZARD — Electrical Grounding Required.

- Never remove the round grounding prong from the plug and never use a two-prong grounding adapter.
- Never use an extension cord to connect power to the unit.

Go on to **8 Level the Unit**.

8 Level the Unit

Leveling Information

IMPORTANT

It is extremely important that the unit is level. If it is not level, the ice mold will not fill evenly.

1. Use a level to check the levelness of the unit from front to back and from side to side. Level should be placed along top edge and side edge as shown (see **Figure 27**).

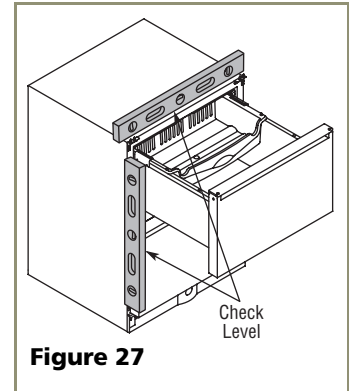

Figure 27

2. If the unit is not level, adjust the feet on the corners of the unit as necessary (see **Figure 28**).

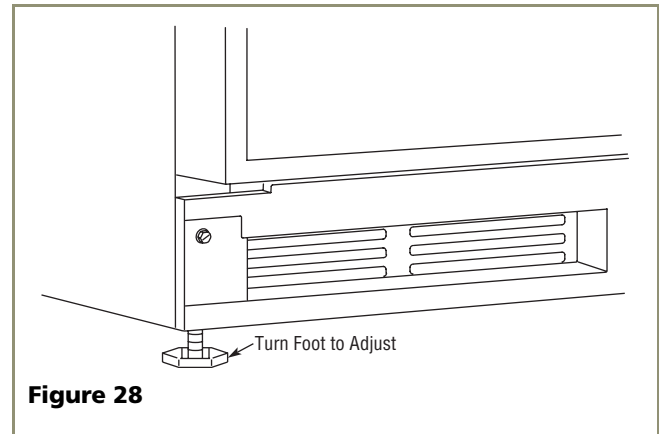

Figure 28

3. Check the levelness after each adjustment and repeat the previous steps until the unit is level. Go on to **9 Install the Unit**.

Installation Tip

If the room floor is higher than the floor in the cut-out opening, adjust the rear feet to achieve a total unit rear height of 1/8" less than the opening's rear height. Shorten the unit height in the front by adjusting the front feet. This allows the unit to be gently tipped into the opening. Readjust the front feet to level the unit after it is correctly positioned in the opening.

9 Install the Unit

Installation of the CO2075DWR

1. Make sure the ON/OFF switch is in the OFF position.
2. Open the water supply valve in the main water source.
3. Plug in the power cord.
4. Gently push the unit into position. Be careful not to kink the water supply line or entangle the electrical cord.
5. Re-check the leveling, from front to back and side to side. Make any necessary adjustments. The unit's top surface should be approximately 1/8" below the countertop.

Anti-Tip Kit Installation

⚠ WARNING

- **The Anti-Tip Kit must be installed on this unit before it is used.**
- **Additional blocking or special fasteners may be required for installation. Installer is responsible for secure attachment to prevent the unit from tipping.**
- **Make sure the mounting screws attaching the unit to the counter, cabinet or wall are deep enough into the mounting surface to support the weight of the drawers and the items that will be inside the drawers.**
- **Never use the drawers as steps or as a shelf to support more than the drawers' content. Serious personal injury could occur.**

After leveling, the unit must be secured to a counter, a cabinet or a wall to prevent tipping.

1. Open the upper drawer to expose the six screws (A) installed at the top two corners (three at each corner). Remove the appropriate screws for horizontal or vertical mounting (see **Figure 29**). Do not discard.

Horizontal Mounting (Left Side Shown)

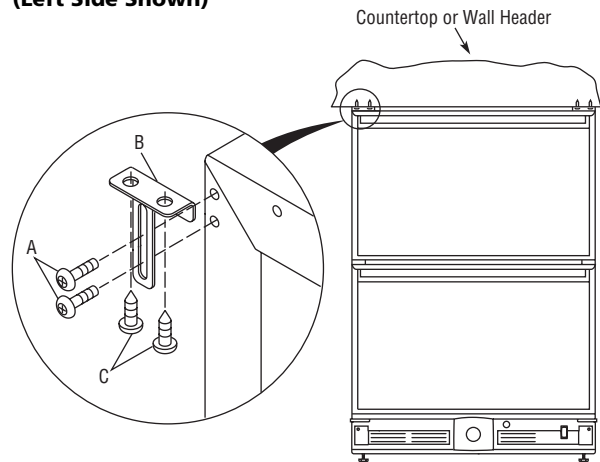

Vertical Mounting (Left Side Shown)

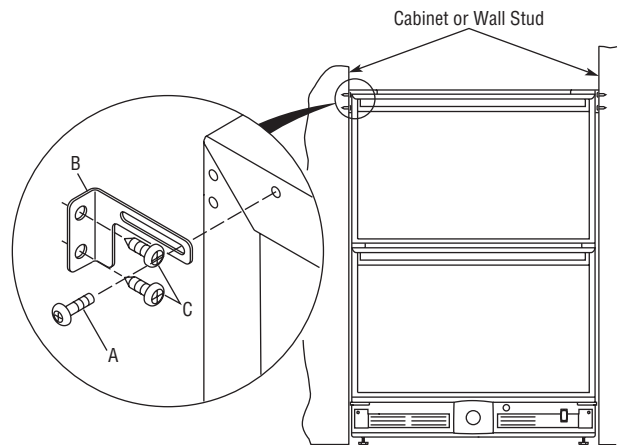

Figure 29

2. Insert the screws through the anti-tip bracket (B) and attach the bracket to the unit. Tighten screws securely.
3. Repeat for the other side.

Note: The bracket should be flush with the surface it is being attached to. If it is not, loosen the screws and slide the bracket against the mounting surface. Tighten screws securely.

- Using two of the screws (C) supplied, fasten the screws through the bracket and into the counter, cabinet or wall.

IMPORTANT

Certain cabinets or countertops may require special fasteners or additional wood blocking to anchor properly.

CAUTION

Make sure the screws are back far enough so they do not damage any exposed front surface of the cabinet.

Installation Troubleshooting

Q: Problem

Water is leaking under the unit.

A: Solution

A water leak under the unit is most likely caused by a bad connection in the water supply line. Make sure the water line's brass fitting is screwed tight to its valve and threaded correctly.

Q: Problem

The drawer remains open unless it is pushed closed.

A: Solution

The drawer should be self-closing when it is open approximately 8". If this is not, re-check leveling from front to back of the unit and readjust if necessary.

10 Start-Up for the First Time

Initial Start-Up

Once installation and leveling is complete, the unit is ready for initial start-up and operation. The ON/OFF switch is located in the front grille (see **Figure 30**).

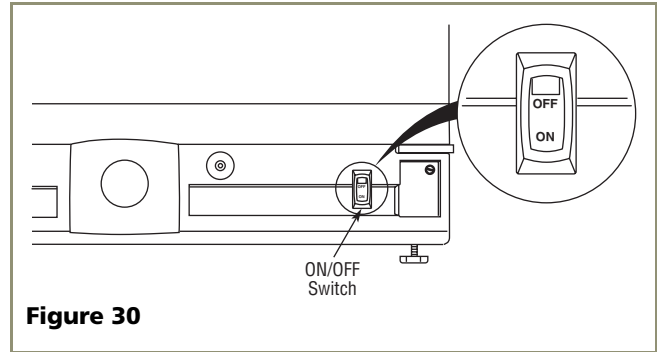

Figure 30

- Put the ON/OFF switch in the ON position.

Note: There is an interior light in each drawer which illuminates when the drawer is opened.

- As soon as the ice maker reaches the proper temperature, the ice maker mechanism will fill the mold with water.

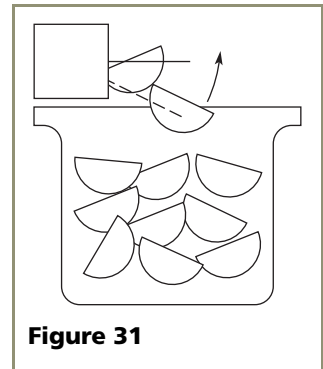

Figure 31

Note: The first cubes may be small because of air in the water line. After two hours, cubes will be standard size.

- The ice maker will continue to produce until the bin is full. You may interrupt production by raising the bin arm into an upright and locked position (see **Figure 31**). While the bin arm is locked, the unit will maintain temperature for ice storage.

IMPORTANT

It is possible that dirt or scale will dislodge in the water line. Always throw away all ice cubes made during the first twenty-four (24) hours of operation.

Temperature Controller

The temperature controller (**Figure 32**) is located in the top drawer. It consists of an LED display, two LED status indicator lights and three touchpad buttons. The LED display shows the refrigerator temperature set point and is calibrated in degrees Fahrenheit. The controller is factory programmed for a set point of 38°F for the top drawer which will show when the unit is first powered up. The factory set point for the ice compartment is 0°F.

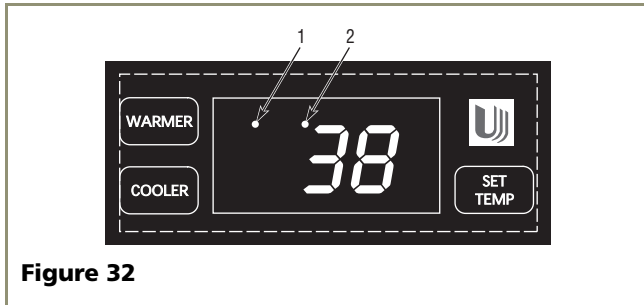

Figure 32

To display actual temperature in the refrigerator, press the “WARMER” button momentarily. A solid status indicator light (1, **Figure 32**) will show the air temperature reading in the cabinet for approximately 10 seconds.

To adjust the temperature set point, press the “SET TEMP” button momentarily; the display will flash. Press the “WARMER” or “COOLER” button as desired to change the set point. When the desired set point shows on the display, wait 10 seconds and the new set point will be saved. Wait 24 hours for the temperature to stabilize before checking the actual temperature again. The refrigerator set point range is 34°F to 45°F.

To check the temperature in the ice compartment, press the “WARMER” button momentarily, and then press and hold “COOLER” for three seconds.

For more information, see the User Manual. For a quick reference to indicator light status, see the table below.

Indicator Light Status

LED	Status	Indicates
1	<ul style="list-style-type: none"> • Solid • Flashing 	<ul style="list-style-type: none"> • Refrigerator temperature displayed • Not Applicable
2	<ul style="list-style-type: none"> • Solid • Flashing 	<ul style="list-style-type: none"> • Freezer temperature displayed • Open thermistor — call for service

Other Settings

Other settings for the unit are factory preset. No adjustments should be necessary at this time. See the User Manual for information on:

- Removing the upper drawer’s storage bin
- Removing the lower drawer’s ice bucket
- Adjusting the upper drawer’s organizer, left-to-right or front-to-back

Start-Up Troubleshooting

Q: Problem

Unit does not appear to turn on when switch is set to ON.

A: Solution

Make sure unit is plugged in and outlet has power (circuit breaker has not tripped).

Q: Problem

Water does not appear to be flowing into unit.

A: Solution

Check that the water is connected and turned on and the line is not obstructed. Remember that the ice maker mechanism will not fill the mold with water until the mold reaches the proper temperature.

Q: Problem

The cubes produced during the first two to three hours of operation have been discarded. New cubes still appear cloudy.

A: Solution

This is normal and is caused by air being trapped in the cube during fast freezing.

IMPORTANT

See the User Manual’s *Troubleshooting Guide* for more solutions.

Échelon™ Series

Who to Call

Service Information

If the need for service arises, contact the dealer from whom the unit was purchased. State the Model Number and Serial Number and explain the problem. The Model and Serial Number plate is located inside unit at upper right hand corner.

If you need to locate a service company, you can go online at **www.U-LineService.com** and search for a service company by zip code.

For more than four decades, U-Line has distinguished itself as the leader in built-in undercounter ice making, refrigeration and wine storage appliances.

Échelon™ SERIES / *O r i g i n s* SERIES

U-Line Corporation, located in Milwaukee, WI, is a family operated manufacturer of built-in undercounter icemakers, Combo® icemaker/refrigerators, Wine Captain® wine storage units, refrigerators, refrigerated drawers and refrigerator/freezers.

Free Manuals Download Website

<http://myh66.com>

<http://usermanuals.us>

<http://www.somanuals.com>

<http://www.4manuals.cc>

<http://www.manual-lib.com>

<http://www.404manual.com>

<http://www.luxmanual.com>

<http://aubethermostatmanual.com>

Golf course search by state

<http://golfingnear.com>

Email search by domain

<http://emailbydomain.com>

Auto manuals search

<http://auto.somanuals.com>

TV manuals search

<http://tv.somanuals.com>