

Varimixer



SPARE PART AND OPERATION MANUAL FOOD MIXER Model W20D

Caution -READ BEFORE OPERATING- Caution

Varimixer recommends that mixer operators be at least 18 years of age and be thoroughly trained on the use of the mixer.

Varimixer recommends that the following precautions be adopted to help make the mixer operation safer and more efficient.

- All operators should be at least 18 years of age.
- All operators should be thoroughly trained before being allowed to operate the mixer.
- NEVER reach into the bowl when the mixer is running.
- Do not wear loose clothing or rings while operating the mixer.
- Stop the mixer and lower the bowl before adding ingredients, scraping the bowl, removing the agitator, or removing the product.
- Stop the mixer before removing or installing attachments into the drive hub.
- Do not attempt to assemble or disassemble attachments while mounted into the drive hub.
- Always use the pusher plate with the slicer/meat grinder attachments.
- NEVER bypass the safety mechanisms supplied on the mixer. Doing so can cause injury and is the responsibility of the user to insure these safety mechanisms are operating properly.

Mixer Capacity Chart

Cookie, Dough	14 Lbs.
Muffins	24 Lbs.
Mashed Potatoes	17 Lbs.
Pancakes, Waffles	9 Qts.
Whipped Cream	4 Qts.
Cake, Layer	23 Lbs.
Eggs & Sugar	9 Lbs.
Icing , Fondant	14 Lbs.
Egg Whites	1 Qt.
Cake, Cup	25 dz.
Cookies, Sugar	40 dz.



LIMITED WARRANTY

Varimixer warrants its commercial mixers to the original purchaser against defects in material or manufacture for a period of one year from the date of original purchase, subject to the following exclusions and limitations. The warranties provided by Varimixer do not apply in the following instances:

EXCLUSIONS

1. In the event that the equipment is improperly installed. Proper installation is the responsibility of the installer, proper installation procedures are covered in the Varimixer Spare Parts and Operations Manual.
2. In the event that the equipment is improperly maintained. Proper maintenance is the responsibility of the user. Proper maintenance procedures are covered in the Varimixer Spare Parts and Operations Manual.
3. In the event that failure or malfunction of the appliance or any part thereof is caused by abnormal use or is otherwise not attributable to a defect in material or manufacture.
4. In the event that the appliance, by whatever cause, has been materially altered from the condition in which it left the factory.
5. In the event that the rating plate has been altered or removed.
6. On parts which would normally be worn or replaced under normal conditions.
7. With regard to adjustments and/or calibrations. Checking of and changes in adjustments and calibrations are the responsibility of the installer, Proper installation is the responsibility of the installer, proper installation procedures are covered in the Varimixer Spare Parts and Operations Manual.

If any oral statements have been made regarding the appliance, such statements do not constitute warranties and are not part of the contract of sale. This Limited Warranty constitutes the complete, final and exclusive statement with regard to warranties.

THIS LIMITED WARRANTY IS EXCLUSIVE AND IS IN LIEU OF ALL OTHER WARRANTIES WHETHER WRITTEN, ORAL OR IMPLIED, INCLUDING, BUT NOT LIMITED TO, ANY WARRANTY OF MERCHANTABILITY OR FITNESS FOR PARTICULAR PURPOSE OR WARRANTY AGAINST LATENT DEFECTS.

LIMITATIONS OF LIABILITY

In the event of warranty claim or otherwise, the sole obligation of Varimixer shall be the repair and/or replacement at the option of Varimixer, of the appliance or component or part thereof. Such repair or replacement shall be the expense of Varimixer *except* that travel over 100 miles or two hours, overtime, and holiday charges shall be, the expense of the purchaser. Any repair or replacement under this warranty does not constitute an extension of the origin, warranty for any period for the appliance or for any component part thereof. Parts to be replaced under this warranty will be repaired or replaced at the option of Varimixer with new or functionally operative parts. The liability of Varimixer on any claim of any kind, including claims based on warranty, expressed or implied, contract, negligence, strict liability or any other theories shall be solely and exclusively the repair or replacement of the product as stated herein, and such liability shall not include, and purchaser specifically renounces any rights to recover, special, incidental, consequential or other damages of any kind whatsoever, including, but not limited to, injuries to persons or damage to property, loss of profits or anticipated profits, or loss of use of the product.

TO SECURE WARRANTY SERVICE

If you claim a defect covered by this Limited Warranty, first direct your claim to the local Authorized Service Agency, giving model, serial and code numbers, voltage, a description of the problem and your sales slip. If this procedure fails to be satisfactory to you, you may write to the Varimixer National Service Manager, 5489 Campus Dr, Shreveport, Louisiana 71129; you should include the information listed above.

TABLE OF CONTENTS

Installation Instructions.....	2
Cleaning Instructions.....	2
Operating Instructions.....	3
Front Panel Controls.....	4
Main Body.....	5
Bowl Arms.....	7
Pulley System.....	9
Planetary Head.....	11
Attachment Drive.....	13
Computer Display Panel.....	15
Bowl Screen.....	17
Tools and Bowls.....	19
Electrical Diagrams.....	21
Adjusting the Bowl Height.....	22
Planetary Head Removal.....	23

Read this page entirely BEFORE beginning installation.

VARIMIXER INSTALLATION INSTRUCTIONS

The mixer must be mounted with the rubber feet, which neutralize both shaking and rusting. If the unit is to be installed on top of a table, the unit must be bolted down with the two bolts supplied from the shipping pallet.

Before the mixer is connected to power, it should be checked that the voltage and frequency on the rating plate is correct in relation to the place of installation. The rating plate is located on the rear right side of the mixer.

WARNING

Electrical and grounding connections must comply with applicable portions of the National Electrical Code and/or other local electrical codes.

CLEANING

The mixer should be cleaned daily or after use. The mixer should be cleaned with a soft cloth and clean water. Sulphonated soaps should be used with caution as they destroy the mixer's lubricants.

Never use high pressure cleaning for the mixer.

Bowls and tools of aluminium must not be washed with strong alkaline detergents (pH not bigger than 9.0).

The soap suppliers can recommend the correct type of soap.

The mixer should be unplugged before cleaning to prevent accidental starting while cleaning.

The inside of the beater shaft should be cleaned once a day with warm, soapy water.

DOUGH HOOK CLEANING

Special care should be given to cleaning the dough hook. We recommend that it be cleaned and sanitized in a commercial dish machine. An alternate cleaning procedure is to vigorously scrub the hook with a hot water and detergent solution. Use a heavy bristled brush. After cleaning, sanitize the hook by rinsing it with a 50 ppm solution of sodium hypochlorite.

Operation of the Mixer.

Power Up and Default:

1. Turn power on Mixer. (Plug in 115AC)
 - 1:00 Appears on the display.
 - The slow speed LED lights. (Left LED)
2. Press the bar arrow between the slow and fast LEDs.
 - 2:00 Appears on the display.
 - The fast speed LED lights. (Right LED)
3. Press the bar arrows between the slow and fast LEDs.

Note: These are the factory default times for slow and fast speed. The computer will go to factory or stored times on every power up.

Setting The Slow Speed Time:

1. With the computer's Slow speed LED on. (Left LED)
2. Enter the desired time for slow speed.(minutes and seconds)
 - Press the time up keys under the display.
 - 99:59 is the Maximum time that can be entered.

Setting The Fast Speed Time:

1. Press the bar arrows between the slow and fast LEDs.
2. Enter the desired time for fast speed.(minutes and seconds)
 - Press the time up keys under the display.
 - 99:59 is the Maximum time that can be entered.

Storing Set Times:

1. With the desired slow and fast speed times entered Press and hold the bar arrow between the LEDs until "stor" appears on the display. The time stored will be the default time on power up.

Start and Stop:

1. With the desired time for slow and fast speed entered. Press the GREEN Start button.
 - a. The computer will start the mixer in slow speed counting down from the entered time.
 - b. The slow speed LED will flash until the slow speed counter counts down.
- c. If no time is entered in the slow speed counter the computer will default to a 5 sec. slow speed count down.
- d. At the end of slow speed count down the computer will automatically Start the fast speed timer; which will count down from the entered time and will stop when the counter times out.
- e. The fast speed LED will flash until the fast speed counter counts down.
- f. Entering 0:00 as the fast speed time will only allow you to run in slow speed.
When the slow speed timer counts down the mixer will stop.
2. The Mixer can also be Stopped by Pressing the RED Stop button.
 - a. The computer will return to the time entered.

Fixed Mode Operating Procedure

Getting to Fixed mode:

1. With the mixer off (unplugged) Press and hold the four time up keys located under the display.
 2. Turn the power on the mixer (plug in 115AC)
 3. Release the time up keys when Set appears in the display.
 - - - - - appears on the display
- b. The time stored from the normal mode will be the fixed time until it is changed.

Operation of the Mixer.

Change Time in Fixed mode:

1. Press and hold the bar arrow key for 5 sec. and release.
2. The fixed time for the slow speed will appear in the display.
 - The LED for slow speed lights. (Left LED)
3. Press the time up keys under the display to enter the desired time for slow speed.
4. Press the bar arrow key.
5. The fixed time for the fast speed will appear in the display.
 - The LED for fast speed lights.(Right LED)
6. Press the time up keys under the display to enter the desired time for fast speed.
7. Press and hold the bar arrow key until stor appears in the display.
 - - - - - will appear in the display
8. Press the start button to run fixed times.

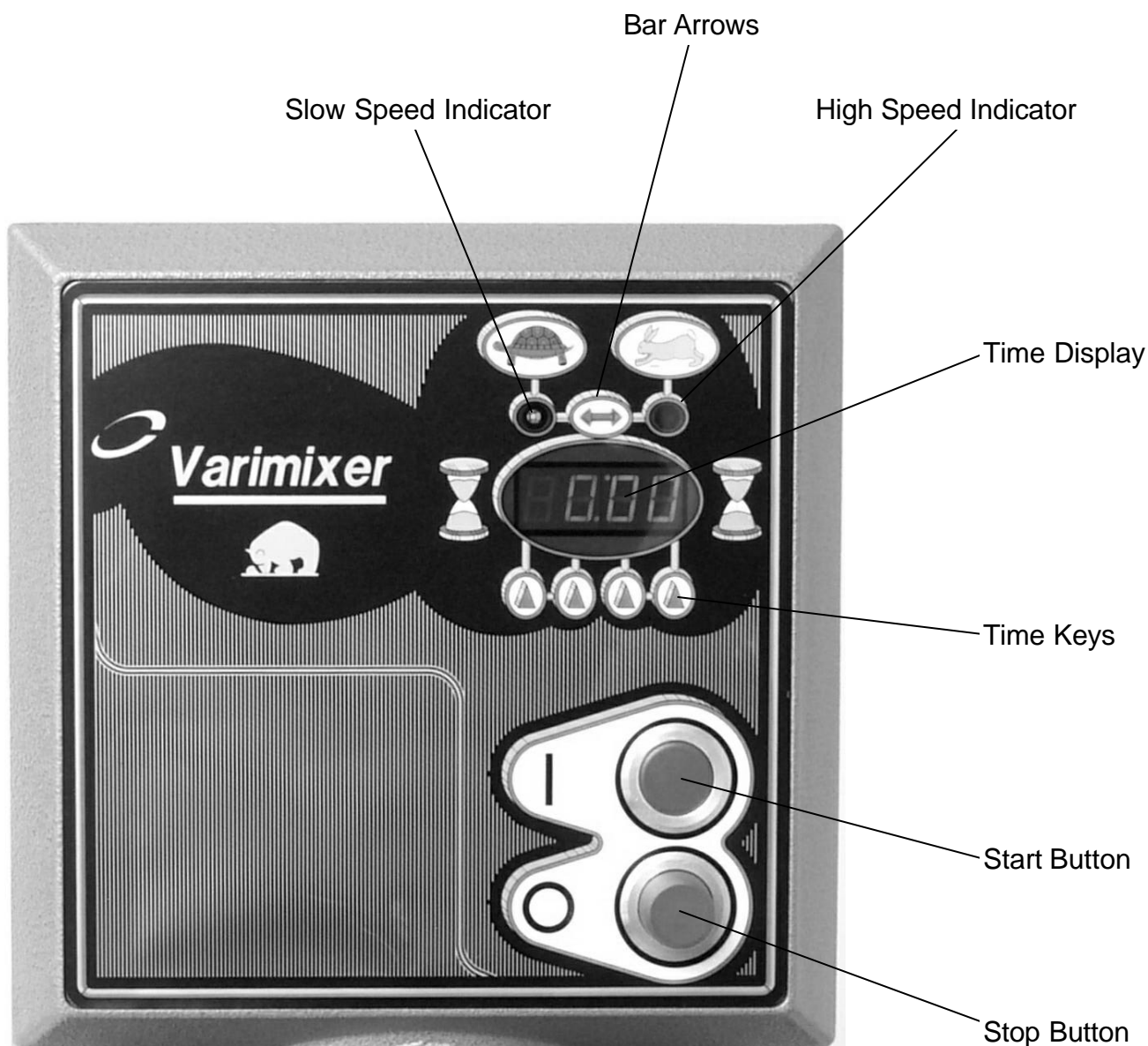

Body

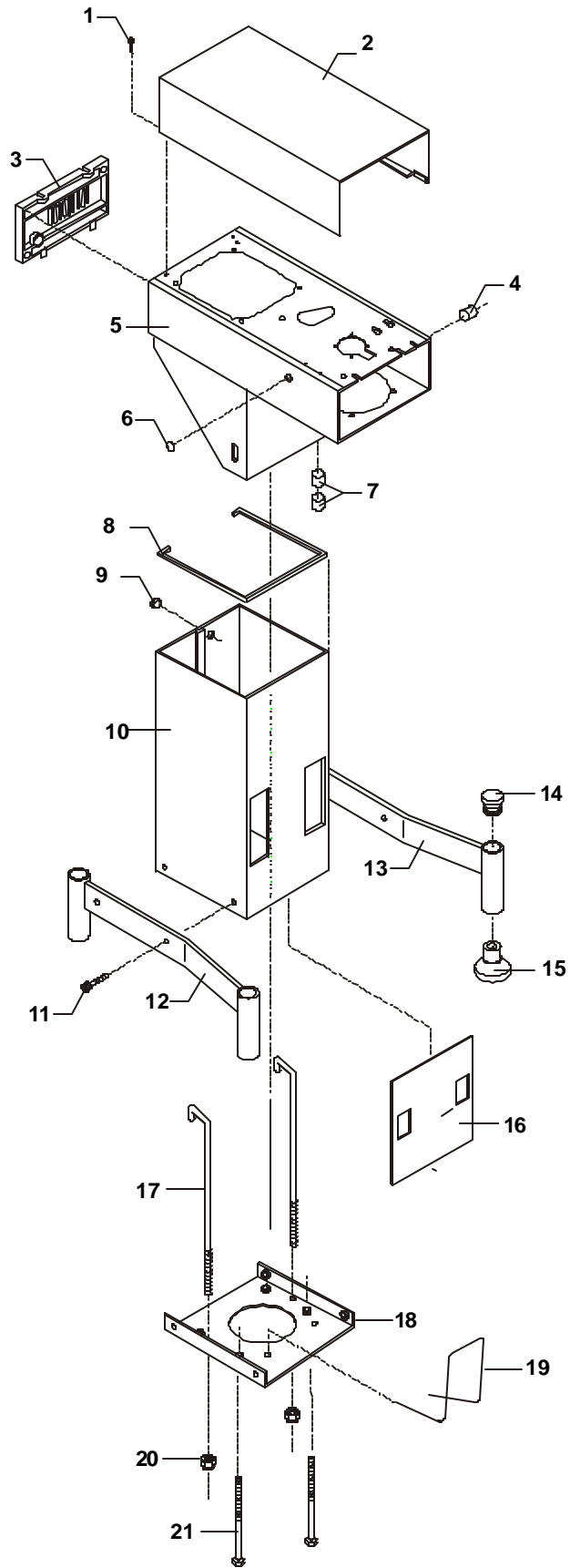

Body

<u>Figure Number</u>	<u>Description</u>	<u>Part Number</u>
1.	Screw	STA 5233
2.	Top Lid (Painted)	20D-21
3.	Rear Access Plate	20N-291
4.	Bushing (Lift Handle)	STA 2515
5.	Upper Column	20N-22.17
6.	Plug Button	STA 6561
7.	Bushings	STA 2514 (each)
8.	Column Seal	20N-207
9.	Plug Button	STA 6511
10.	Lower Column	20N-22.30
11.	Bolt M8X20	STA 5631
12.	Leg Left	20N-25.1
13.	Leg Right	20N-25.2
14.	Plug Button	STA 6560
15.	Rubber Foot	20N-218
16.	NSF Cover Plate	20N-304
17.	Suspension Hook	20N-302
18.	Column Base Plate	20N-22.35
19.	Retaining Spring f/Plate	20N-310
20.	Lock Nut M6	STA 5831
21.	Mixer Mount Bolt	STA 5441

Bowl Arms

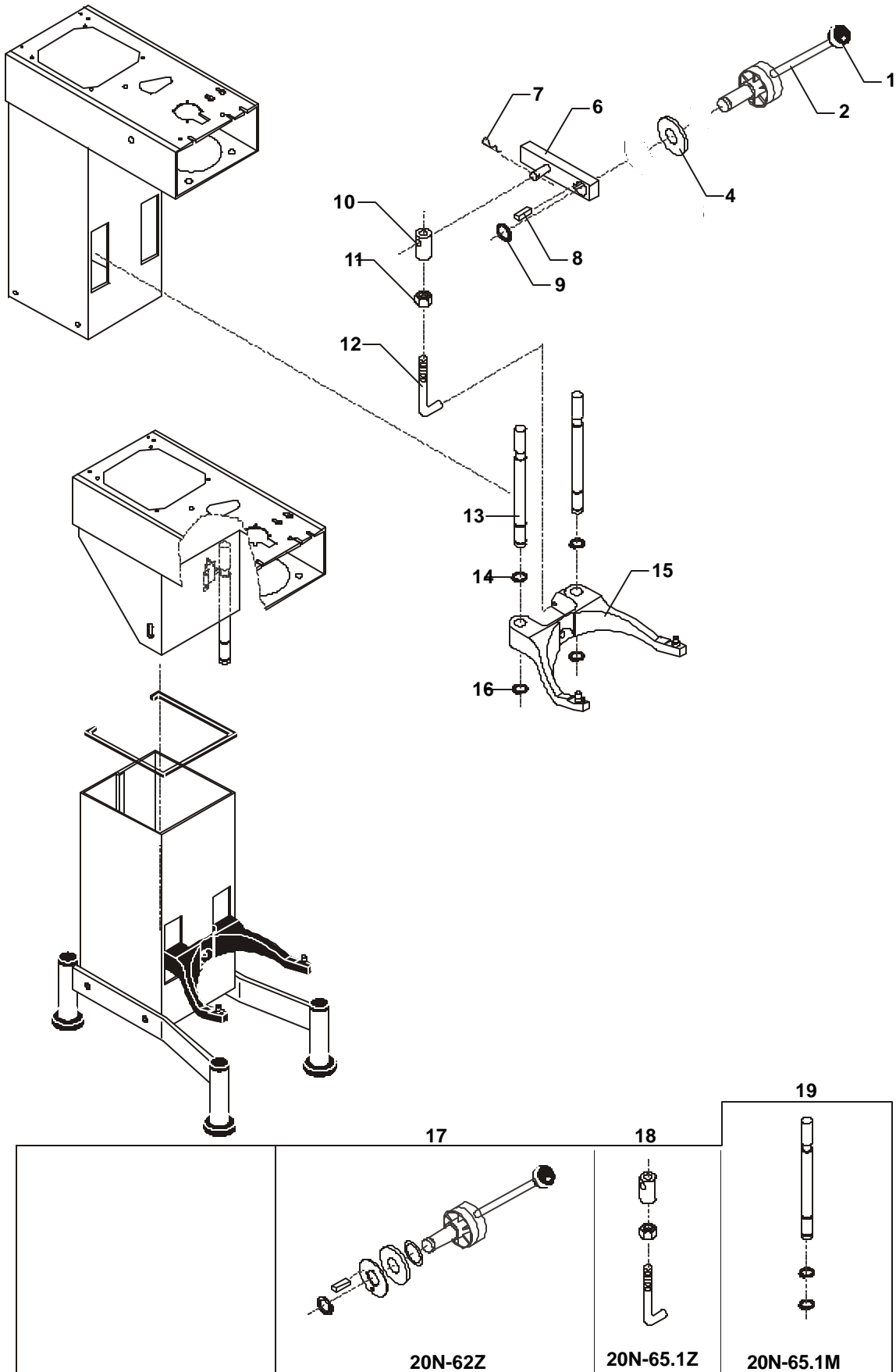

Bowl Arms

<u>Figure Number</u>	<u>Description</u>	<u>Part Number</u>
1.	Ball (Black)	STA 3306
2.	Bowl Lift Lever	20N-62Z
3.		
4.	Disc With Arrow	20N47.10
5.		
6.	Crank Arm	20N-63M
7.	Cotter Pin	STA 6204
8.	Key	STA 2019
9.	Snap Ring	STA 3407
10.	Lift Nut	20N-65.1Z
11.	Jam Nut	STA 5825
12.	Lift Bolt	20N-83.1
13.	Bowl Arm Shaft	20N-68.1M
14.	Snap Ring 25U	STA 3410
15.	Bowl Arm	20N-23
16.	Snap Ring 25U	STA 3410
17.	Bowl Lift Lever Assembly	20N-62Z
18.	Lift Bolt Assembly	20N-65.1M
19.	Bowl Arm Shaft Assembly	20N-68.1M

Pulley System

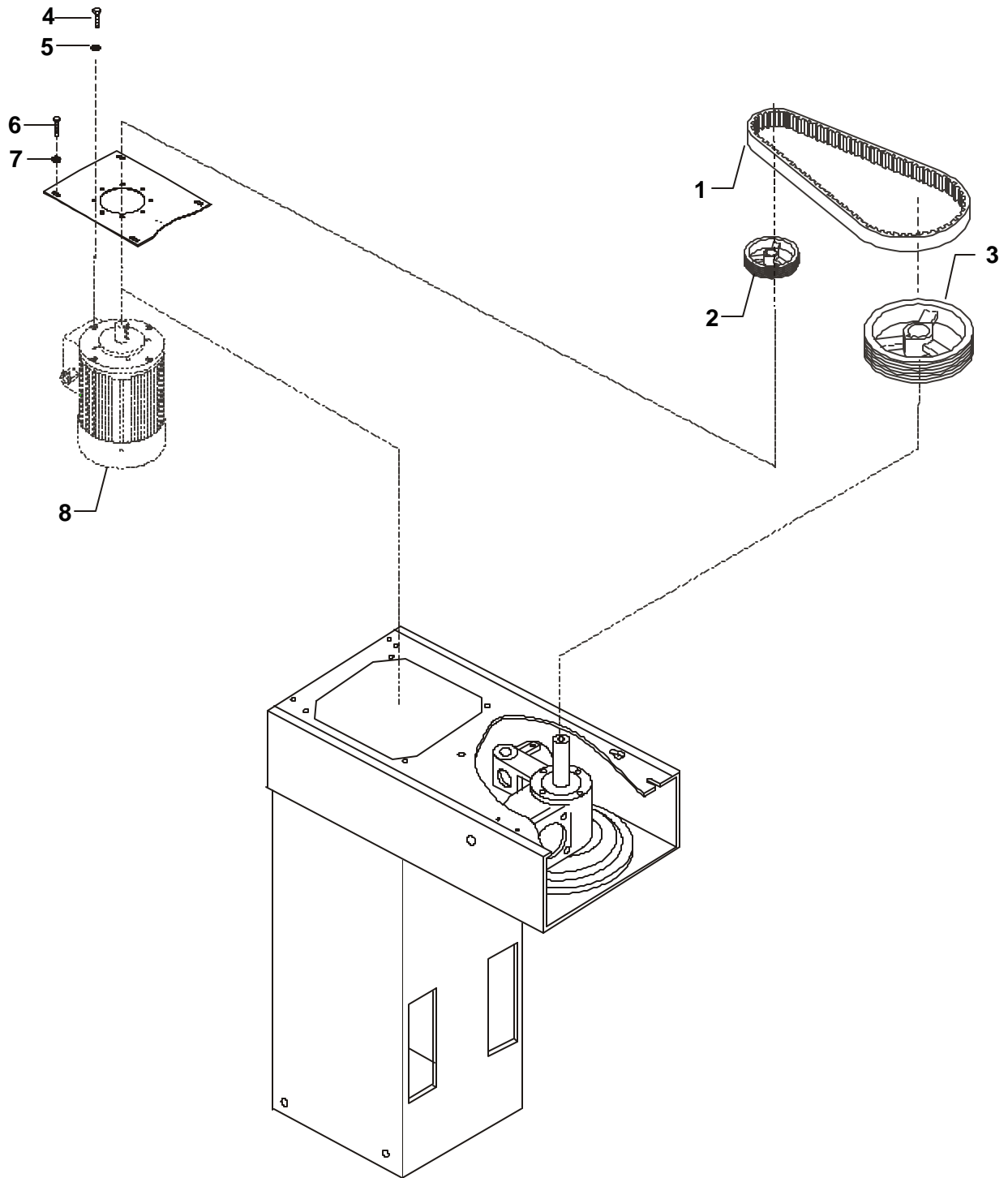

Pulley System

<u>Figure Number</u>	<u>Description</u>	<u>Part Number</u>
1.	Belt	20P-91
2.	Motor Pulley	6J19
3.	Planetary Pulley	6J60
4.	Bolt 3/8-16X3/4	Local Purchase Item
5.	Washer	STA 6009
6.	Bolt M6X16	STA 5432
7.	Washer	STA 6008
8.	Motor	20D-85.64

Planetary Head

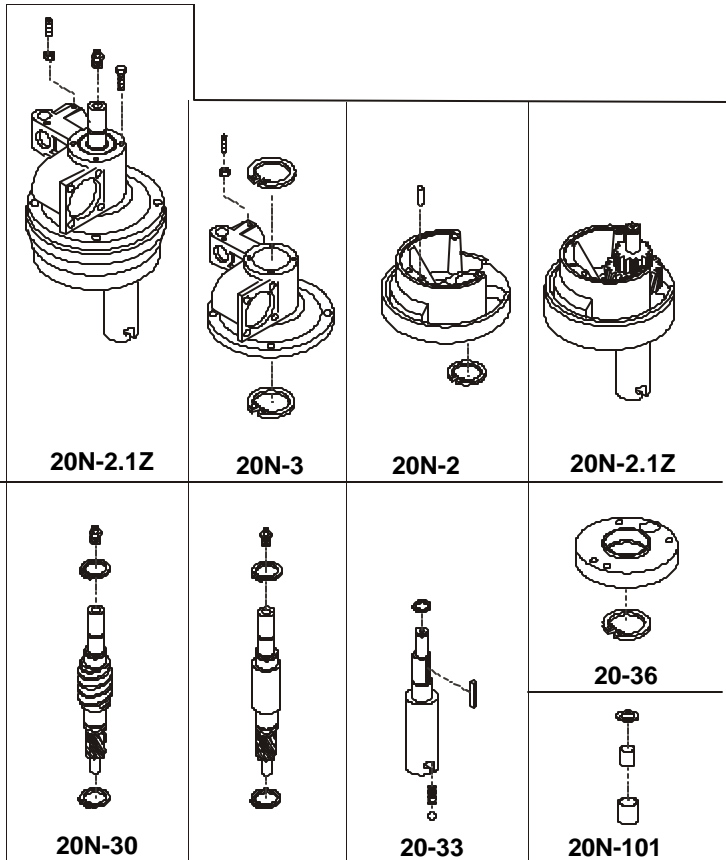
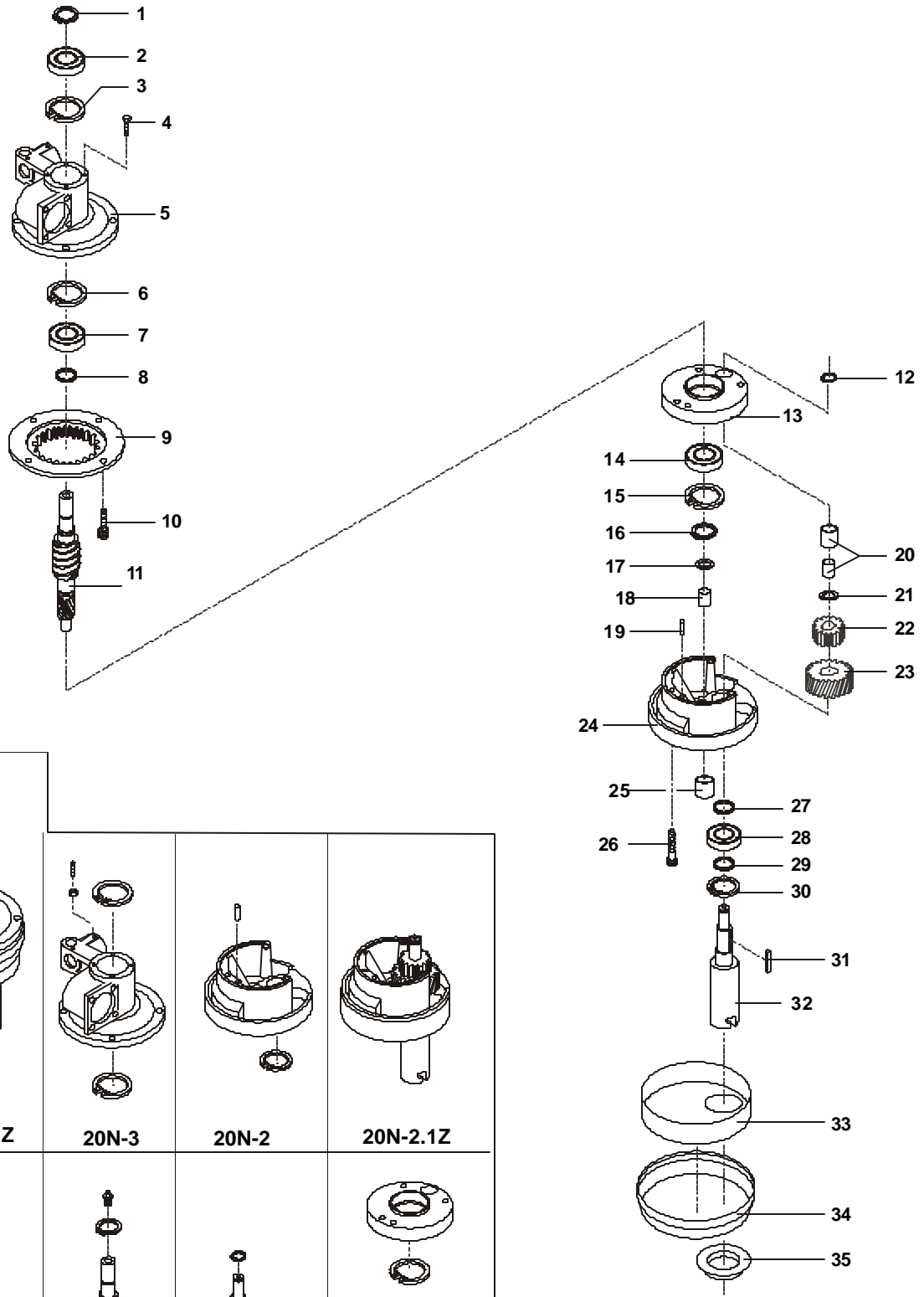

Planetary Head

<u>Figure Number</u>	<u>Description</u>	<u>Part Number</u>
1.	Snap Ring	STA 3414
2.	Bearing 6206	20-98
3.	Snap Ring	STA 3518
4.	Bolt M6X16	STA 5432
5.	Main Bearing Head	20N-3
6.	Snap Ring	STA 3518
7.	Bearing 6206	20-98
8.	Distance Piece	20-37
9.	Gear Wheel Rim	20N-1
10.	Bolt M8X30	STA 5626
11.	Main Shaft	20N-30
12.	Snap Ring	STA 3470
13.	Eccentric Disc	20-36
14.	Bearing 6006	20-100
15.	Snap Ring	STA 3515
16.	Snap Ring	STA 3414
17.	Seal	20N-108R
18.	Needle Bearing Race	See item 25
19.	Groove Pin	STA 6460
20.	Needle Bearing set	20-96
21.	Disc	20-235
22.	Upper Rim Pinion	20-31
23.	Lower Rim Pinion	20-32
24.	Eccentric Head	20N-2
25.	Needle Bearing	20N-101
26.	Bolt	STA 5641
27.	Distance Piece	20-34
28.	Bearing 6205	20-97
29.	Distance Piece	20-34
30.	Snap Ring	STA 3514
31.	Key	STA 2008
32.	Bayonet Shaft	20-33
33.	Stainless Cover	20-272
34.	Black Cover	20-272.1
35.	Rubber Ring	20-209

Attachment Drive

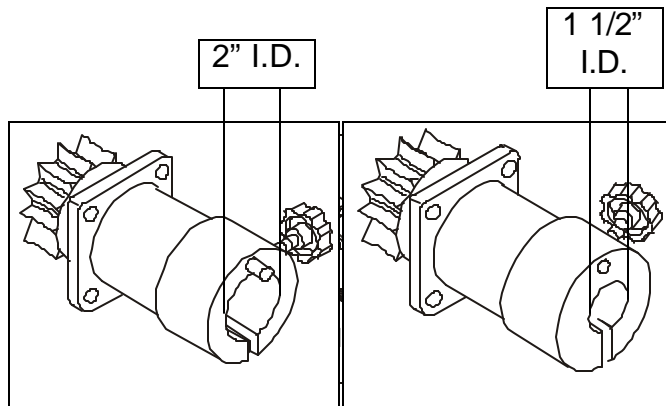
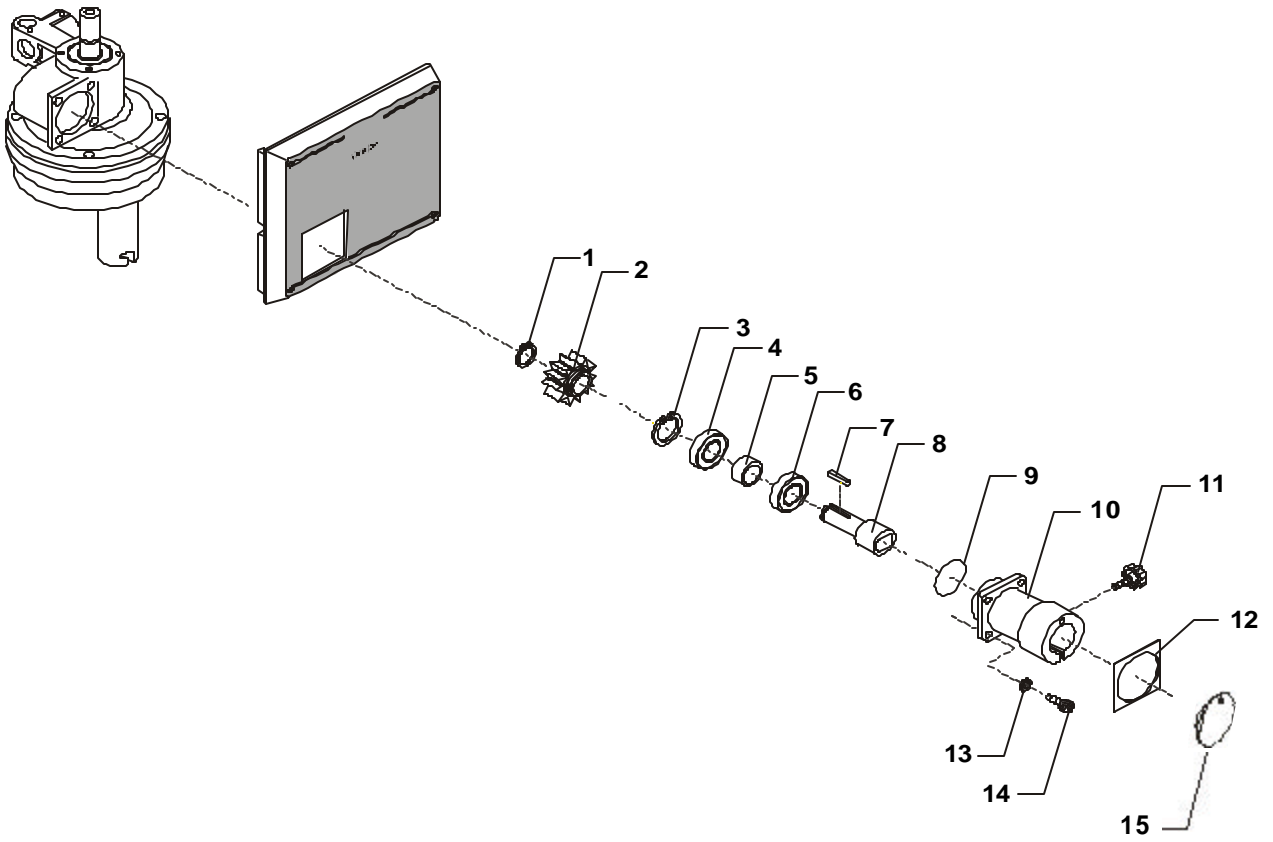

20N-10.5M
#17 Hub

20N-10.6M
#12 Hub

Attachment Drive

<u>Figure Number</u>	<u>Description</u>	<u>Part Number</u>
1.	Snap Ring	STA 3410
2.	Wormwheel	20N-9
3.	Snap Ring	STA 3512
4.	Bearing	15-105
5.	Distance Piece	20N-37
6.	Bearing	15-105
7.	Key	STA 2031
8.	Shaft F/ #17 Hub	20N-50
8A.	Shaft F/ #12 Hub	20J-50
9.	O-ring	STA 3127
10.	Hub F/ #17 (2" I.D.)	20N-8
10A.	Hub F/ #12 (1 1/2" I.D.)	20J-8
11.	Thumb Screw F/ #17	STA 5561
11A.	Thumb Screw F/ #12	4R-125
12.	Gasket	20N-211
13.	Lock Washer	STA 6038
14.	Bolt	STA 5631
15.	Cover F/ #17	15-214
15A.	Cover F/ #12	312C

Computer Display Control

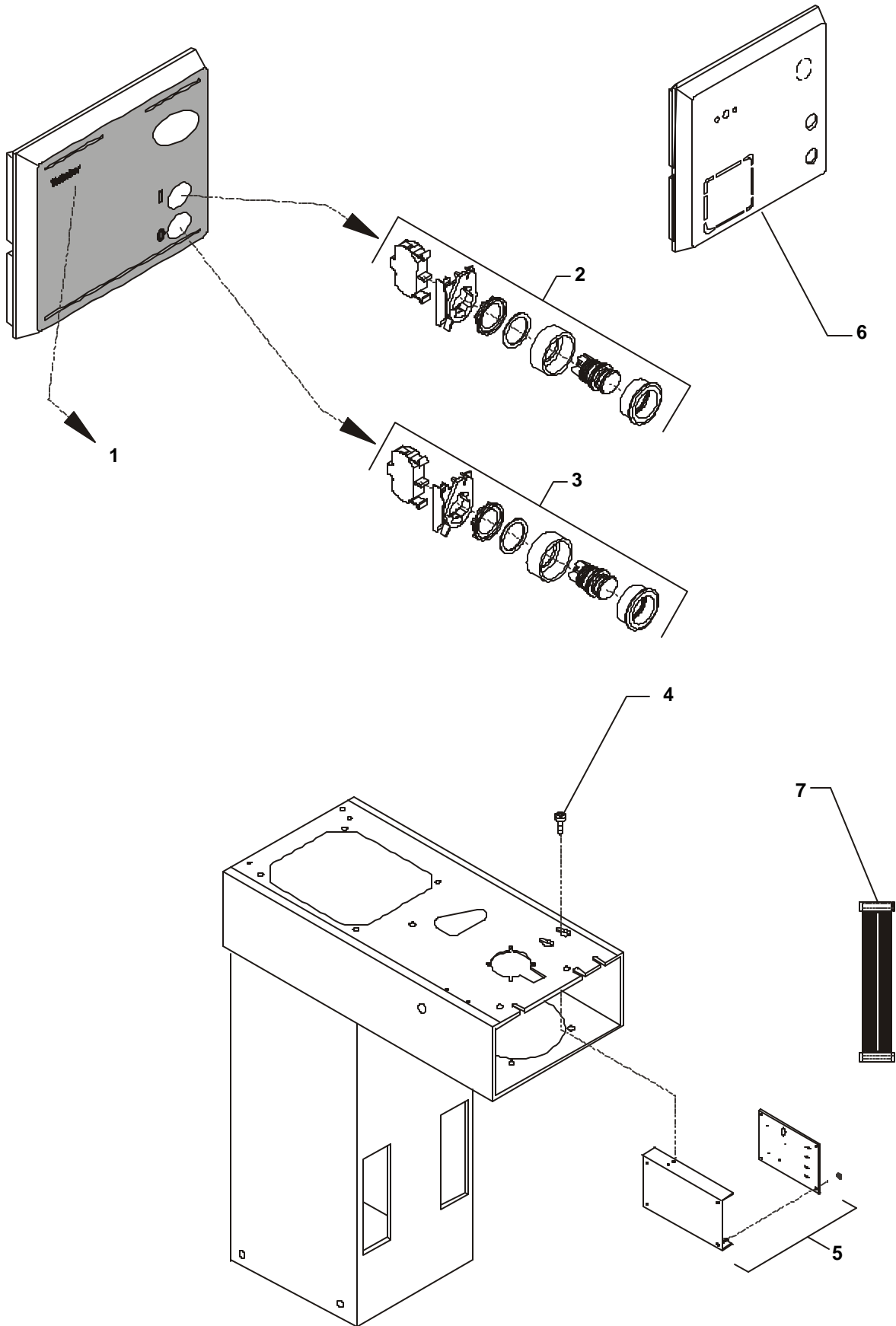

Computer Display Control

<u>Figure Number</u>	<u>Description</u>	<u>Part Number</u>
1.	Control Panel Assembly <i>with start/stop buttons and computer display.</i>	20E-605M
2.	Start Button Assembly	31-174.2
3.	Stop Button Assembly	31-174.3
4.	Screw	STA 5230
5.	Interface Board Assembly	20E-606
6.	Front Plate Casting	20N-650.5
7.	Ribbon Cable	8073882
8.	Cube Relay	8070834

Bowl Screen

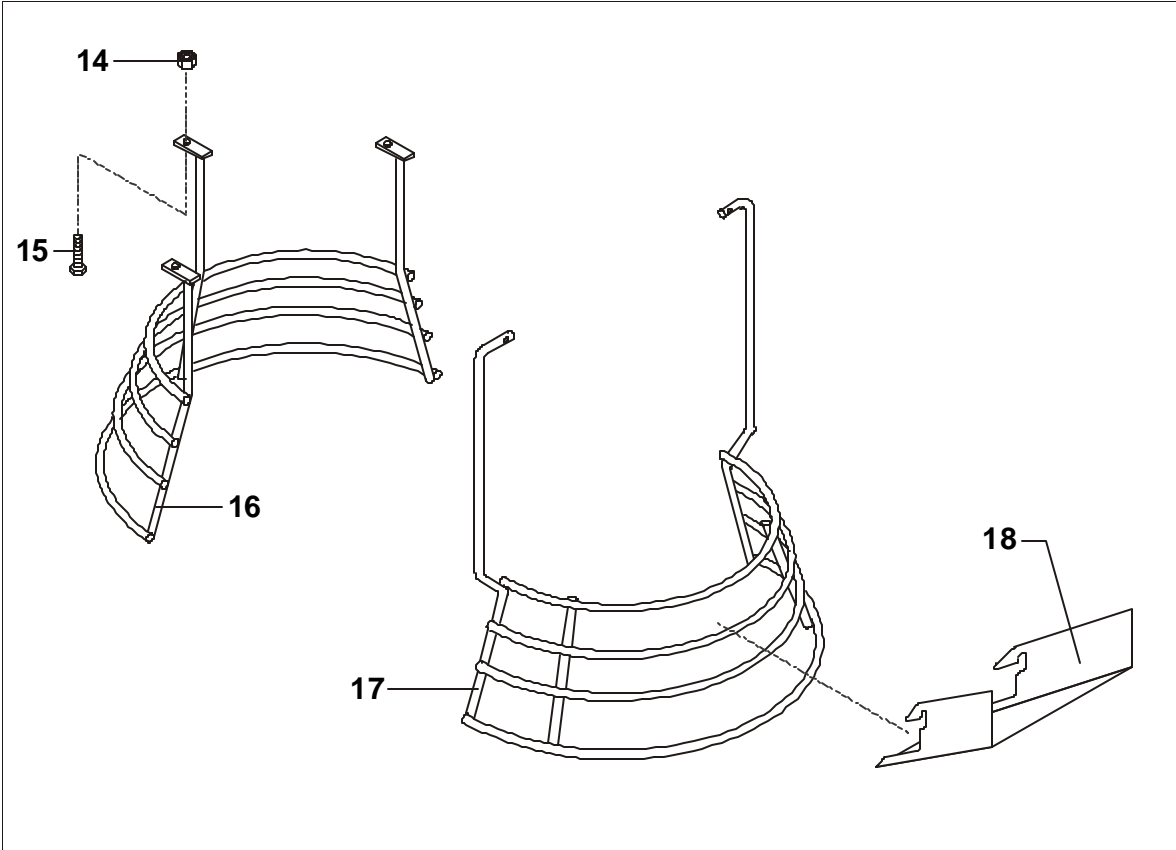
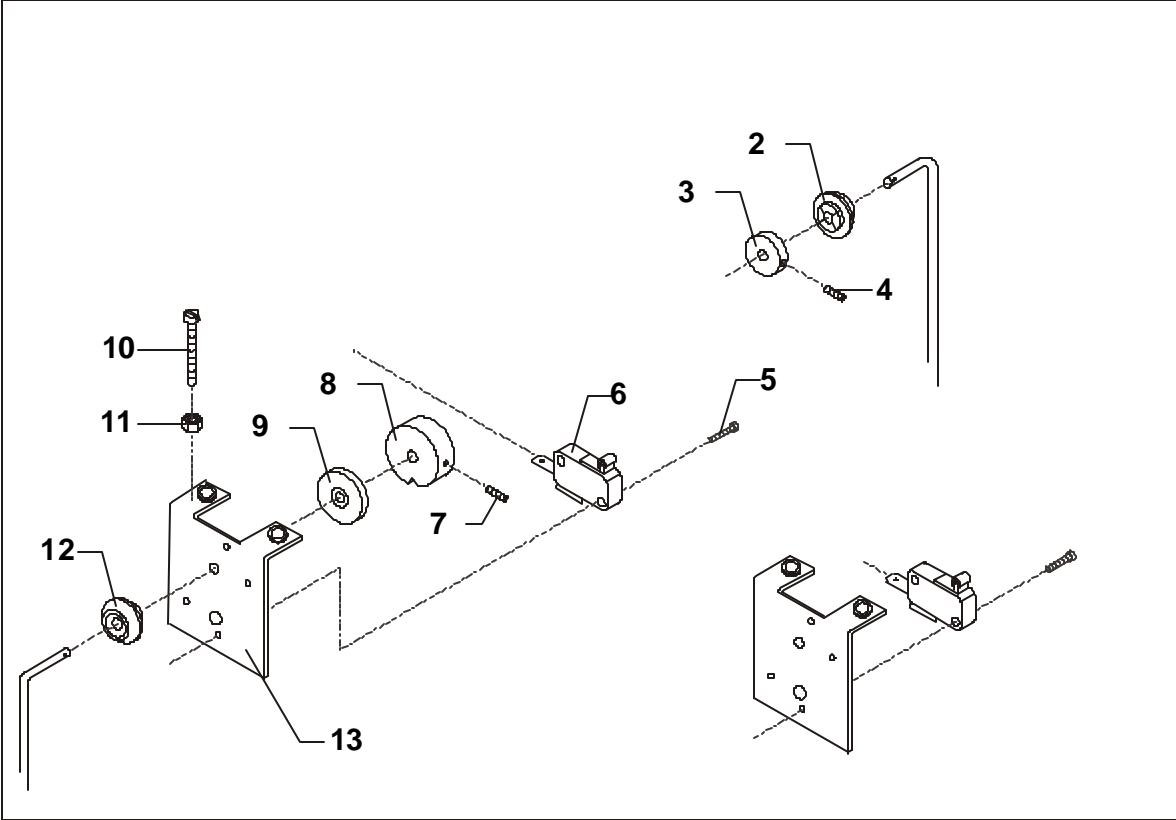

Bowl Screen

<u>Figure Number</u>	<u>Description</u>	<u>Part Number</u>
1.	Bowl Screen Kit	225/20N
2.	Bushing	56SN20-21.1
3.	Cam	56SN20-23
4.	Set Screw	STA 5664
5.	Screw	STA 5251
6.	Microswitch	56SN20-30
7.	Set Screw	STA 5664
8.	Cam	56SN20-22.1
9.	Spacer	56SN20-24
10.	Bolt	STA 5850
11.	Nut	STA 5816
12.	Bushing	56SN20-21.1
13.	Bracket Assembly	56SN30-13
14.	Nut	STA 5850
15.	Bolt	STA 5360
16.	Rear Screen	225/20R
17.	Front Screen	225/20F
18.	Chute	56G20-280

Tools and Attachments

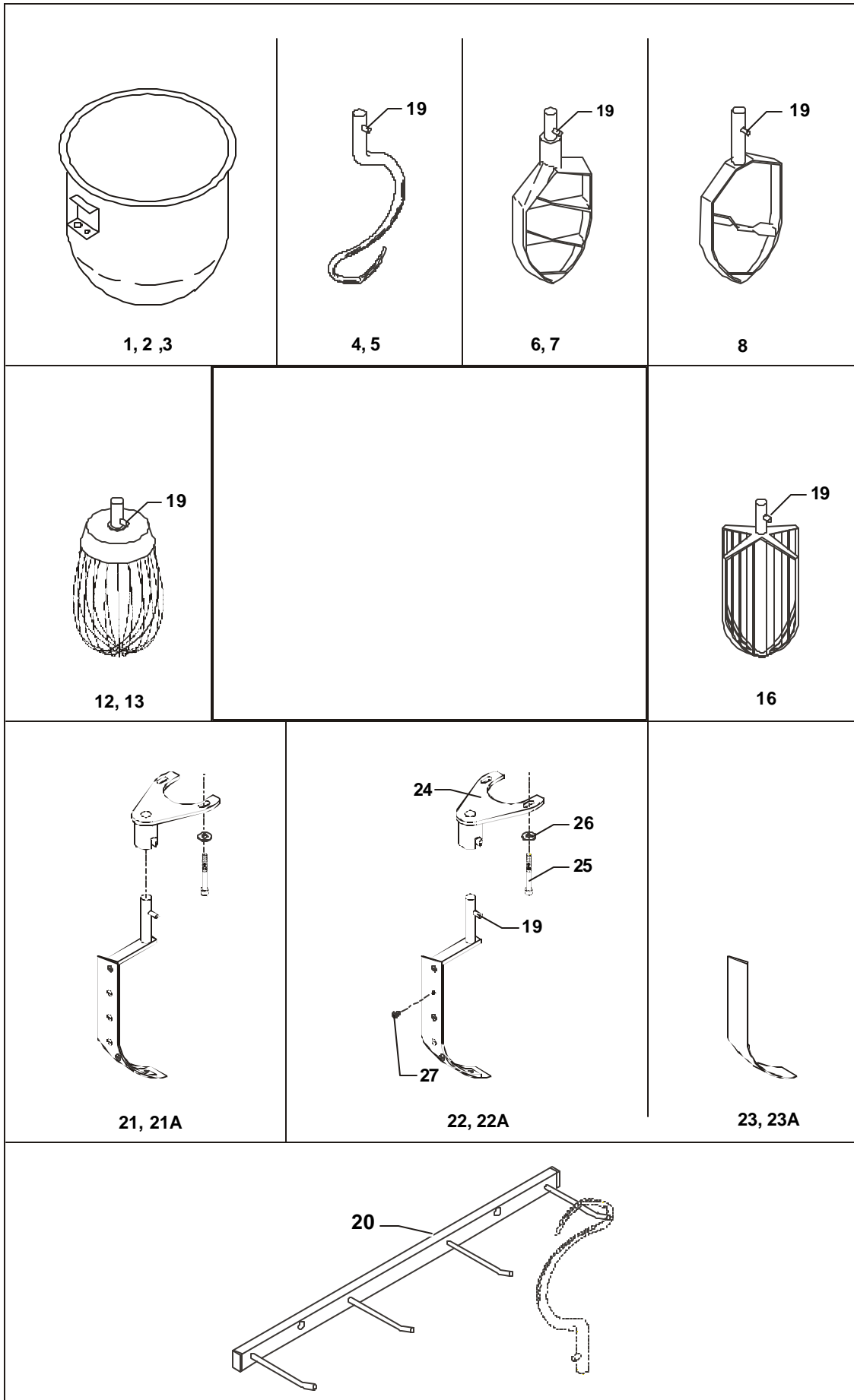

Tools and Attachments

<u>Figure Number</u>	<u>Description</u>	<u>Part Number</u>
1.	S/S Bowl 20Qt	203/20N
2.	S/S Bowl 12Qt.	203/12N
3.	S/S Bowl 25Qt.	203/20C
4.	S/S Hook 20Qt.	213/20A
5.	S/S Hook 12Qt.	213/12N
6.	Flat Beater 20Qt.	205/20A
7.	Flat Beater 12Qt.	205/12N
8.	S/S Flat Beater 20 Qt.	204/20A
12.	Wire Whip 20 Qt.	207/20A
13.	Wire Whip 12 Qt.	207/12N
16.	S/S Wing Whip 20 Qt.	209/20A
19.	Pin	STA 6259
20.	Rack	222
21.	Bowl Scraper 20 Qt.	224/20A
21A	Bowl Scraper 12 Qt.	224/12N
22.	Arm W / Blade 20 Qt.	42R20-102
22A	Arm W / Blade 12 Qt.	42RN12-102
23.	Nylon Blade 20 Qt.	42R20-204
23A	Nylon Blade 12 Qt.	42RN12-204
24.	Scraper Holder	42R20-101M
25.	Bolt	STA 5648
26.	Washer	STA 6020

Wiring Diagram

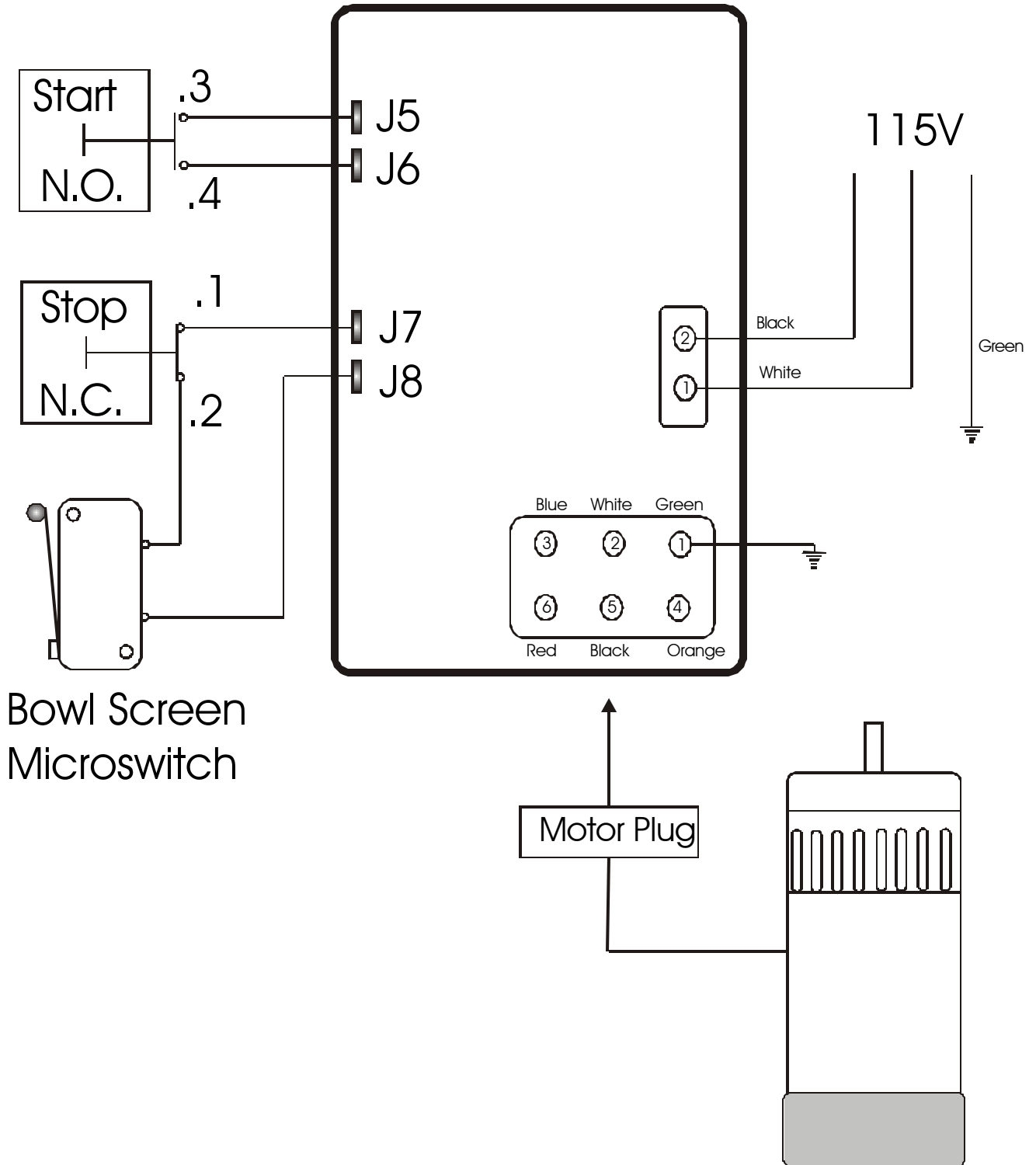

Bowl Height Adjustment

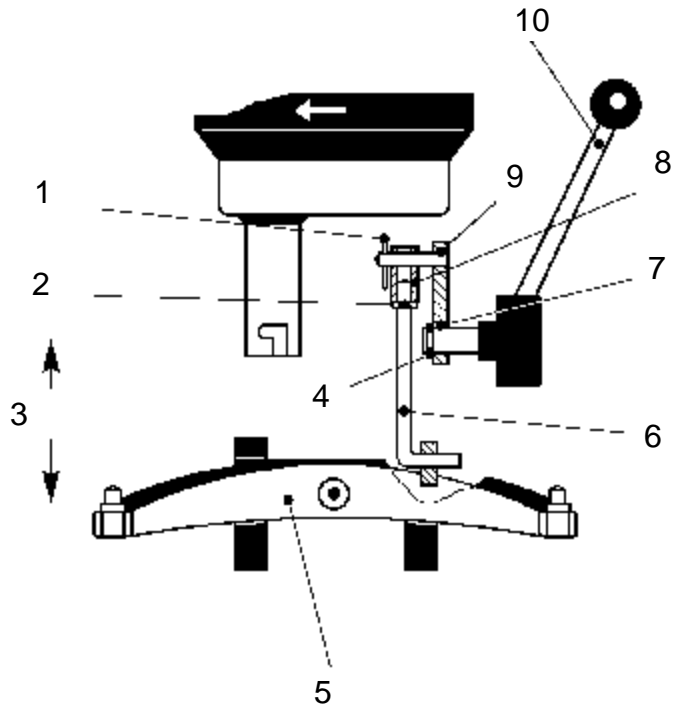

- A) Lower the bowl arms.
- B) Loosen the counter nut (2) and remove the cotter pin. (1)
- C) Remove the lifting bolt (6) and the lifting nut. (8)
- D) Adjust the bowl height by turning the lifting nut (8) either in or out, on the lifting bolt.
- E) Mount the lifting bolt with the lifting nut and the cotter pin, tighten the counter nut. (2)
- D) Ensure all mixing tools fit and do not hit the bowl.

Planetary Head Removal

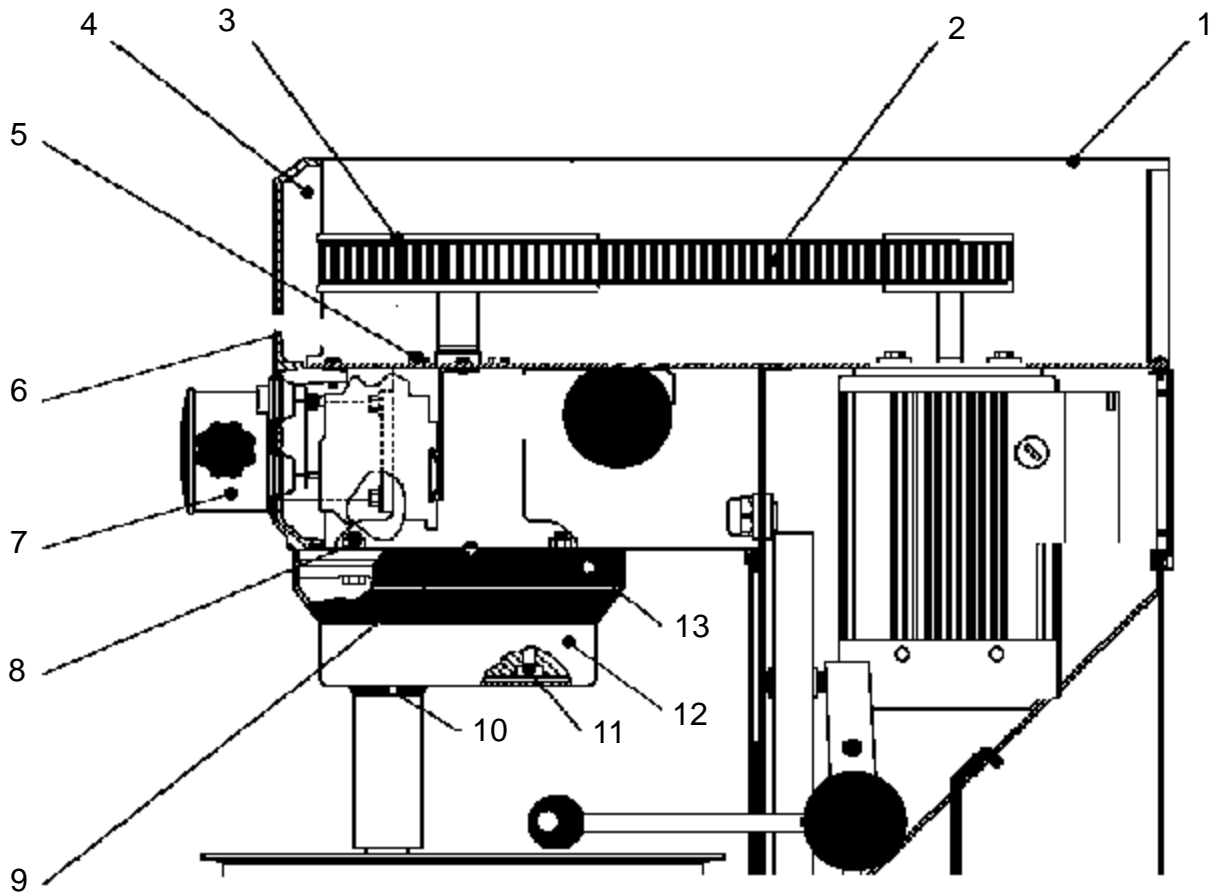

GREASE TYPES

-On repair of the planetary head: Grease the toothed wheel and the toothed rim with Nye Gel 868VH, (PN WHITE GREASE), the needle bearings in the planetary head must not be lubricated with this type of grease, they should be lubricated with Lubriplate #1200-2. Do not use any other type of grease than the ones stated here.

-On repair of the attachment drive: Fill the attachment drive with Tribol Molub 860/150-0, (PN 860/150-0).

Planetary Head Removal

1. Remove the top lid (1), attachment hub (7), the drive belt (2) and the front control panel (4).
2. The plastic ring (13) can be removed with a screwdriver by pressing it between the plastic ring and the frame, and then prying it down.
3. Remove the rubber ring (10) and the stainless steel cover (12) by prying it off with a screwdriver.
4. If only the lower part of the planetary head is to be repaired, the planetary head can be separated by removing the 3 bolts (11).
5. Loosen the set screw and remove the front pulley (3) . A 3 armed pulley puller may be required.
6. Take out the 4 screws (5).
7. By loosening and removing the 4 bolts (8), the planetary can be lowered and removed.



5489 Campus Drive
Shreveport LA 71129
(800) 222-1138
(318) 635-3131 Fax

Free Manuals Download Website

<http://myh66.com>

<http://usermanuals.us>

<http://www.somanuals.com>

<http://www.4manuals.cc>

<http://www.manual-lib.com>

<http://www.404manual.com>

<http://www.luxmanual.com>

<http://aubethermostatmanual.com>

Golf course search by state

<http://golfingnear.com>

Email search by domain

<http://emailbydomain.com>

Auto manuals search

<http://auto.somanuals.com>

TV manuals search

<http://tv.somanuals.com>