



**SPARE PART AND OPERATION MANUAL
FOOD MIXER
Models W30(A), W40(A), W40P, W60(A) and W60P**

Caution -READ BEFORE OPERATING- Caution

Varimixer recommends that mixer operators be at least 18 years of age and be thoroughly trained on the use of the mixer.

Varimixer recommends that the following precautions be adopted to help make the mixer operation safer and more efficient.

- All operators should be at least 18 years of age.
- All operators should be thoroughly trained before being allowed to operate the mixer.
- NEVER reach into the bowl when the mixer is running.
- Do not wear loose clothing or rings while operating the mixer.
- Stop the mixer and lower the bowl before adding ingredients, scraping the bowl, removing the agitator, or removing the product.
- Stop the mixer before removing or installing attachments into the drive hub.
- Do not attempt to assemble or disassemble attachments while mounted into the drive hub.
- Always use the pusher plate with the slicer/meat grinder attachments.
- NEVER bypass the safety mechanisms supplied on the mixer. Doing so can cause injury and is the responsibility of the user to insure these safety mechanisms are operating properly.



LIMITED WARRANTY

Varimixer warrants its commercial mixers to the original purchaser against defects in material or manufacture for a period of one year from the date of original purchase, subject to the following exclusions and limitations. The warranties provided by Varimixer do not apply in the following instances:

EXCLUSIONS

1. In the event that the equipment is improperly installed. Proper installation is the responsibility of the installer, proper installation procedures are covered in the Varimixer Spare Parts and Operations Manual.
2. In the event that the equipment is improperly maintained. Proper maintenance is the responsibility of the user. Proper maintenance procedures are covered in the Varimixer Spare Parts and Operations Manual.
3. In the event that failure or malfunction of the appliance or any part thereof is caused by abnormal use or is otherwise not attributable to a defect in material or manufacture.
4. In the event that the appliance, by whatever cause, has been materially altered from the condition in which it left the factory.
5. In the event that the rating plate has been altered or removed.
6. On parts which would normally be worn or replaced under normal conditions.
7. With regard to adjustments and/or calibrations. Checking of and changes in adjustments and calibrations are the responsibility of the installer, Proper installation is the responsibility of the installer, proper installation procedures are covered in the Varimixer Spare Parts and Operations Manual.

If any oral statements have been made regarding the appliance, such statements do not constitute warranties and are not part of the contract of sale. This Limited Warranty constitutes the complete, final and exclusive statement with regard to warranties.

THIS LIMITED WARRANTY IS EXCLUSIVE AND IS IN LIEU OF ALL OTHER WARRANTIES WHETHER WRITTEN, ORAL OR IMPLIED, INCLUDING, BUT NOT LIMITED TO, ANY WARRANTY OF MERCHANTABILITY OR FITNESS FOR PARTICULAR PURPOSE OR WARRANTY AGAINST LATENT DEFECTS.

LIMITATIONS OF LIABILITY

In the event of warranty claim or otherwise, the sole obligation of Varimixer shall be the repair and/or replacement at the option of Varimixer, of the appliance or component or part thereof. Such repair or replacement shall be the expense of Varimixer *except* that travel over 100 miles or two hours, overtime, and holiday charges shall be, the expense of the purchaser. Any repair or replacement under this warranty does not constitute an extension of the origin, warranty for any period for the appliance or for any component part thereof. Parts to be replaced under this warranty will be repaired or replaced at the option of Varimixer with new or functionally operative parts. The liability of Varimixer on any claim of any kind, including claims based on warranty, expressed or implied, contract, negligence, strict liability or any other theories shall be solely and exclusively the repair or replacement of the product as stated herein, and such liability shall not include, and purchaser specifically renounces any rights to recover, special, incidental, consequential or other damages of any kind whatsoever, including, but not limited to, injuries to persons or damage to property, loss of profits or anticipated profits, or loss of use of the product.

TO SECURE WARRANTY SERVICE

If you claim a defect covered by this Limited Warranty, first direct your claim to the local Authorized Service Agency, giving model, serial and code numbers, voltage, a description of the problem and your sales slip. If this procedure fails to be satisfactory to you, you may write to the Varimixer National Service Manager, 5489 Campus Dr, Shreveport, Louisiana 71129; you should include the information listed above.

TABLE OF CONTENTS

Installation Instructions.....	2
Operating Instructions.....	3
Cleaning-Maintenance.....	4
Belt Adjustments and Removal.....	5
Adjusting the Bowl Height.....	7
Machine Column.....	9
Bowl Arms.....	11
Planetary Head.....	13
Transmission.....	15
Speed Lever Assembly.....	17
Single Speed Transmission.....	19
Attachment Drive.....	21
Instrument Panel.....	23
Bowl Screen.....	27
Vegetable Slicer.....	29
Meat Mincer	37
Bowl Scraper.....	43
Tools and Bowls.....	47
Bowl Truck.....	47
Electrical Diagrams.....	50

Read this page entirely BEFORE beginning installation.

VARIMIXER INSTALLATION INSTRUCTIONS

The mixer must be mounted with the rubber feet, which neutralize both shaking and rusting. Spacers can be inserted under the mixer's feet if the floor is uneven. The mixer can be bolted to the floor if desired.

Before the mixer is connected to power, it should be checked that the voltage and frequency on the rating plate is correct in relation to the place of installation. A unit labeled 220V 3 Phase will operate from 208V to 240V 3 phase safely. The rating plate is located on the rear right side of the mixer. The electrical connection box is located at the top rear of the mixer.

WARNING

Electrical and grounding connections must comply with applicable portions of the National Electrical Code and/or other local electrical codes.

Wire Color Codes

White-Phase 1
Red -Phase 2
Black-Phase 3
Green-Ground
No Neutral is used



1. Lower the bowl lift lever.



2. Remove the bowl and all tools.

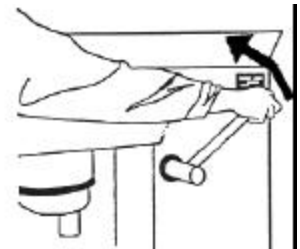

3. Raise the bowl lift.

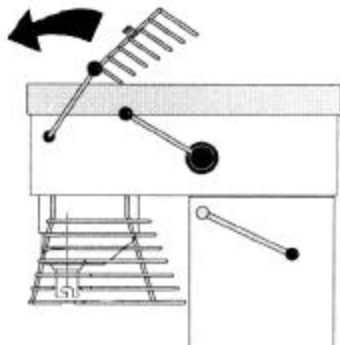

4. Close bowl screen if equipped.

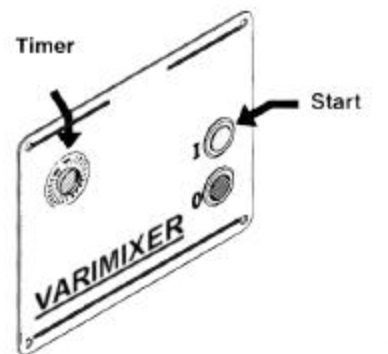

5. Turn timer to 10 minutes and push "start".

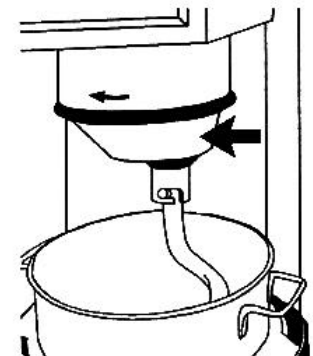

6. Insure cover is rotating in the correct direction.

OPERATION OF THE MIXER:

A) Open the bowl screen and place the bowl in the bowl arms. Note: The bowl arms must be in lowest position and the bowl must be pushed all the way into the bowl arms.(Fig.3).

B) Place the mixing tool in the bayonet shaft. The pin on the tool must be turned into the bayonet hole (fig.2).

C) The bowl is raised to working position by turn of the button for bowl lift (fig.1), ensure that the bowl is placed correctly. Close the bowl screen. If the mixer is equipped with a timer, set the mixing time required by turning the timer (fig 1) clockwise. The mixer will stop automatically, when the time runs out. When the mixer has timed out, the "procedure for starting after emergency stop" is used before the mixer is re-started.

D) Start the mixer by pressing the green start button (fig.1)

The mixer will only start when the bowl is in "up" position, the bowl screen is closed, and the timer is set to time or "hold".

E) Turn the speed selector lever (fig. 4) to the rear until the required speed has been obtained, (notice the recommended maximum speeds on page 3).

F) Before the mixer is stopped, the speed selector lever must be moved back to lowest speed (fig.4).

G) Stop the mixer by pressing the red stop button (fig.1)

PROCEDURE FOR STARTING AFTER EMERGENCY STOP:

1) This procedure must be used in cases where the mixer has been interrupted in high speed.

2) Lower the bowl and remove the tool from the bayonet.

3) Raise the bowl arms, either empty or with the bowl.

4) Close the safety guard, start the mixer and move the speed selector lever back to lowest speed. Switch off the mixer. Now the mixer can be started as usual.

OVERLOAD

Do not overload the mixer. Sticky and heavy doughs may reduce the capacity of the bowl by 75%. The capacity is further reduced if the speed of the mixing tool is increased beyond recommended values or if an incorrect mixing tool is used. Large lumps of fat or cooled ingredients MUST be cut into small parts before they are placed into the bowl or damage can occur to the mixing tool(s).

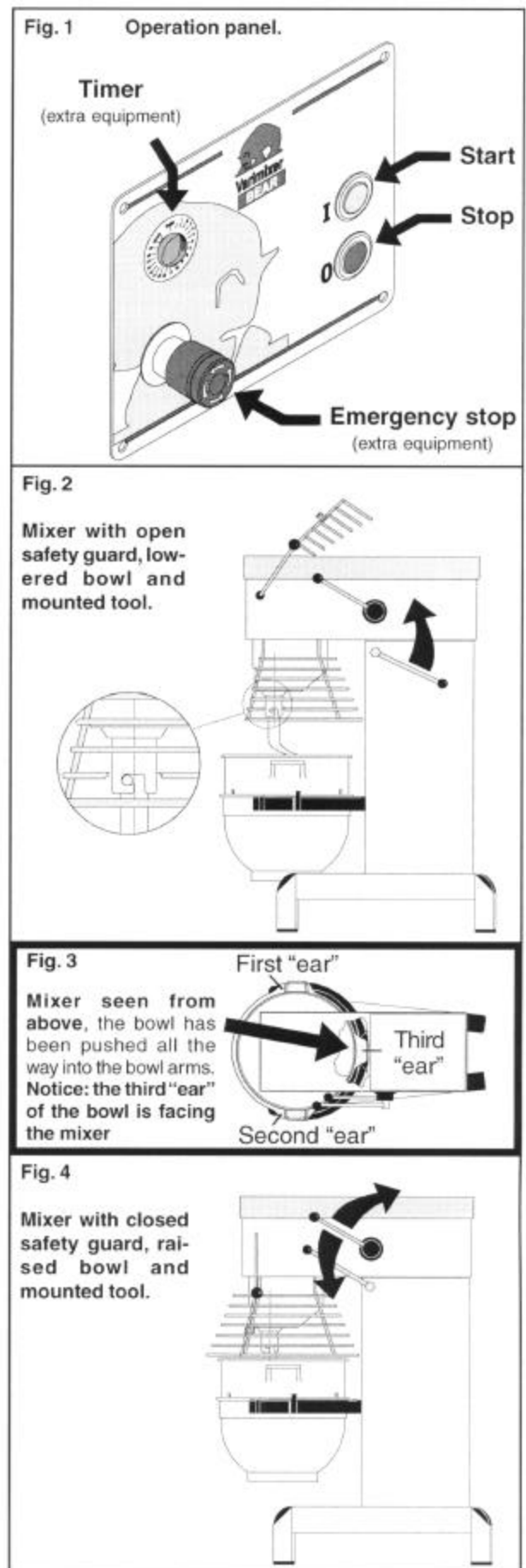

Correct use of tools:

Whips should never be struck against hard objects, this will decrease the life of the tool.

Recommended applications for tools:

Whip	Beater	Hook
Cream	Cakes	Pizza
Egg Whites	Waffles	Bread
Mayonnaise and the like.	Muffins and the like.	Donut Doughs and the like.

Cleaning:

The mixer should be cleaned daily or after use. The mixer should be cleaned with a soft cloth and clean water. Sulphonated soaps should be used with caution as they destroy the mixer's lubricants.

Never use high pressure cleaning for the mixer.

Bowls and tools of aluminium must not be washed with strong alkaline detergents (pH not bigger than 9.0).

The soap suppliers can recommend the correct type of soap.

The mixer should be unplugged before cleaning to prevent accidental starting while cleaning.

The inside of the beater shaft should be cleaned once a day with warm, soapy water.

Dough hook Cleaning: *Special care should be given to cleaning the dough hook. We recommend that it be cleaned and sanitized in a commercial dish machine. An alternate cleaning procedure is to vigorously scrub the hook with a hot water and detergent solution. Use a heavy bristled brush. After cleaning, sanitize the hook by rinsing it with a 50 ppm solution of sodium hypochlorite.*

Maintenance and Lubrication:

The variable speed pulleys must be lubricated regularly, i.e. a lubrication interval of approx. 60 hours of operation.

Lubrication of variable speed pulleys:

- Start the mixer and increase the speed to approx. 50%. Stop the mixer and open the lid on the top of the mixer. On the top of each of the two pulley set shafts is a grease nipple (fig. 5 point 1). Press grease through the grease nipples until the grease gun feels hard to press or until grease comes out between the shaft and the pulleys.
- Start the mixer, and set the speed back to low speed.
- Stop the mixer and fill the grease gun with new grease so that it is ready for next time.

Lubrication of other movable parts:

The movable parts of the bowl arms, the shaft and the lifting rod must also be lubricated with oil. Remove the rear covering and lubricate the marked points with an oil can. (fig.5 pkt.2)

Grease Types:

- Grease for the pulley set shafts: Lubriplate # 1200-2
- On repair of the planetary head: Grease the toothed wheel and the toothed rim with Nye Gel 868VH, (PN WHITE GREASE), the needle bearings in the planetary head must not be lubricated with this type of grease, they should be lubricated with Lubriplate #1200-2. Do not use any another type of grease than the one stated here.
- On repair of the attachment drive: Fill the attachment drive with Tribol Molub 860/150-0, (PN 860/150-0).

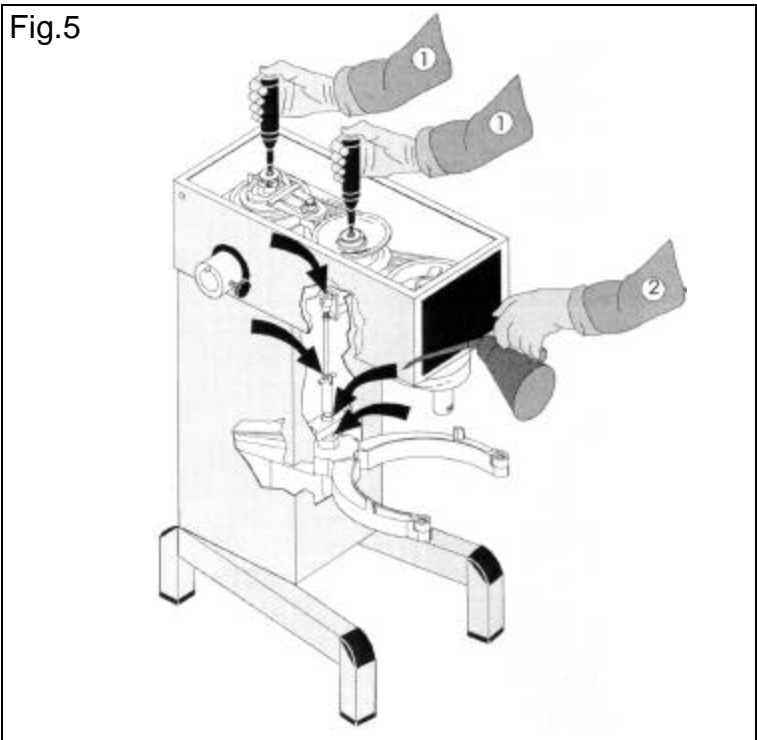

Belt Adjustments and Removal

To remove V-belts or tooth belt:

1. Remove the 4 screws (T) from the control panel.
2. Remove the front control (U) from mixer and let hang from cables.
3. Open lid.
4. Remove nut (J) and washers (H).
5. Remove fork assembly (X).
6. Roll belt (A) off of the the pulleys and remove.
7. Lossen jam nut (E) and tension bolt (F).
8. Loosen bolts (D).
9. Remove 3 V-belts or single tooth belt from planetary pulley (Y) and pedestal assembly (S).

To install V-belts or single tooth belt:

1. Install the 3 V-belts (C) on the pedestal pulley and planetary pulley (Y).
2. Tighten the 2 bolts (D) on the pedestal assembly, insure the v-belts are tight.
3. Install special v-belt (A).
4. Install fork assembly (X).
5. Install washers (G) (H) and nut (J). DO NOT TIGHTEN NUT!
6. On the front pulley set, the stud (K) on the varispeed collar (L) must be placed inside the lower fork (M), and outside the fork on the rear pulley set (N).
7. Start the mixer and tighten the nut (J).
8. Using the speed adjustment lever , lower the speed until the belt (A) is 1/8" from the outside edge of the front var-speed pulley (S). THIS IS LOW SPEED. Adjust the 2 jamnuts (R) against the fork (X) and tighten. This is your low speed setting.
9. Using the speed adjustment lever , increase the speed until the belt (A) is 1/8" from the outside edge of the rear var-speed pulley (L). THIS IS HIGH SPEED. Adjust the bolt (O) down against the motor plate and tighten the jamnut. This is the high speed setting.
10. Using the speed adjustment lever , lower the speed to low. Turn off mixer and set the speed indicator arrow to 70 R.P.M.

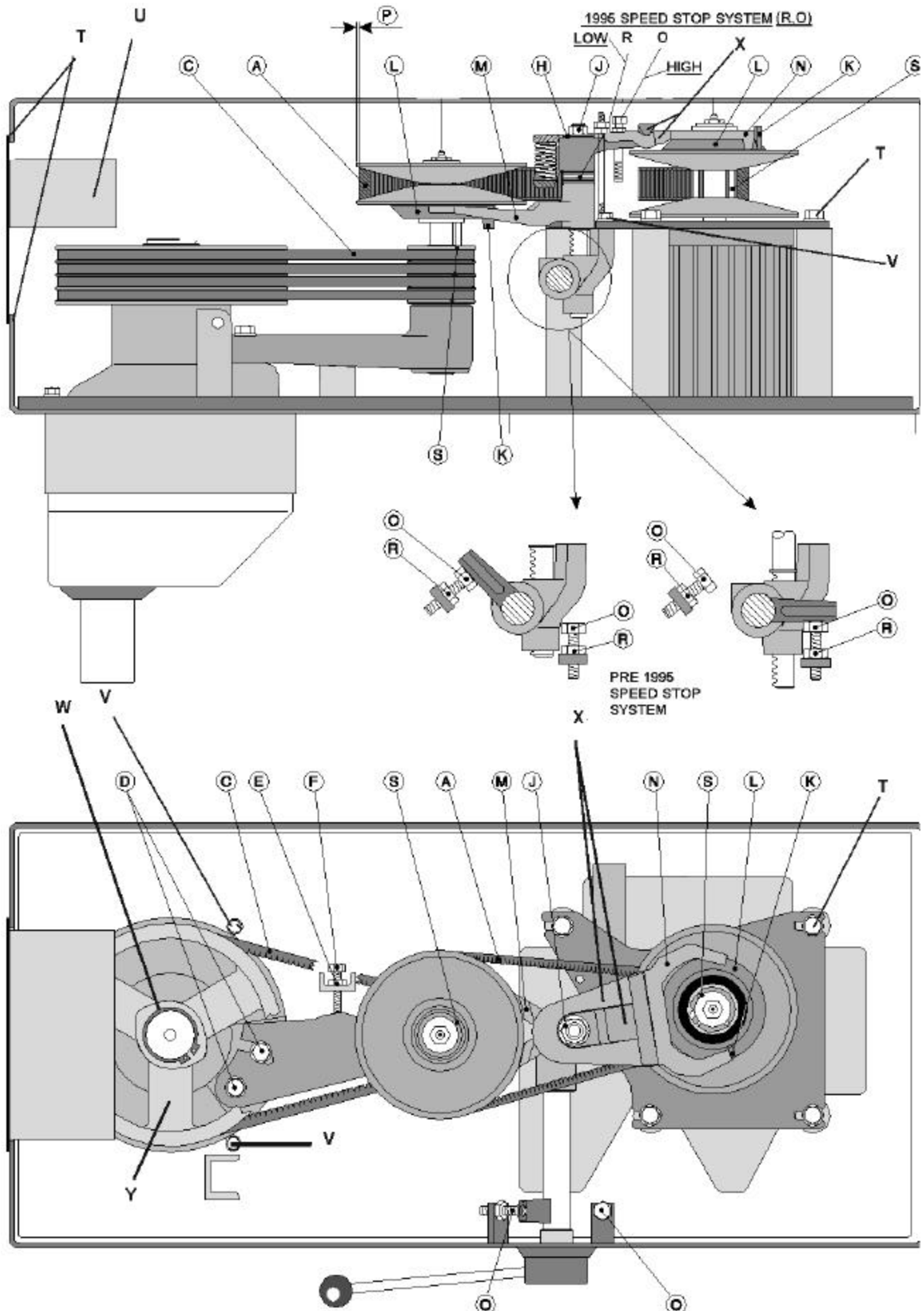

ADJUSTMENT OF BOWL HEIGHT:

The distance (X) is measured from the bottom side of the bayonet hole to the surface on the bowl arms on which the bowl rests (fig.7a). The bowl arms must be lifted to normal working position.

(X):
W30 = 6 3/8"
W40 = 6 3/8"
W60 = 6 15/16"

Lower the bowl arms down on a wooden block so that the weight of the bowl arms are not loading the lifting system. Loosen the counter nut (1), (fig.7b). Take out the cotter pin (2). Take out the lifting rod (3). The lifting bolt (4) is now loose and can be turned out or into the lifting nut (5), until the correct height of the bowl arms has been reached.

ADJUSTMENT OF BOWL FIXING:

The bowl arms must be raised to normal working position. Loosen the counter nuts (1) and remove the cotter pins (2). Turn the bolt (3) until correct fixing of the bowl is achieved. By turning the bolts out of the extension tube the fixing is increased. Start by turning one of the bolts half a revolution.

ADJUSTMENT OF BOWL CENTERING:

Loosen the counter nuts (1) and remove the cotter pins (2). Turn the bolt (3) until the bowl is in the center of the mixer. In order not to alter the fixing of the bowl, one of the bolts must be turned out of the extension tube and the other into the extension tube. Use the flat beater to check that the bowl is correctly centered and turn the planetary head with your hand before the voltage is connected.

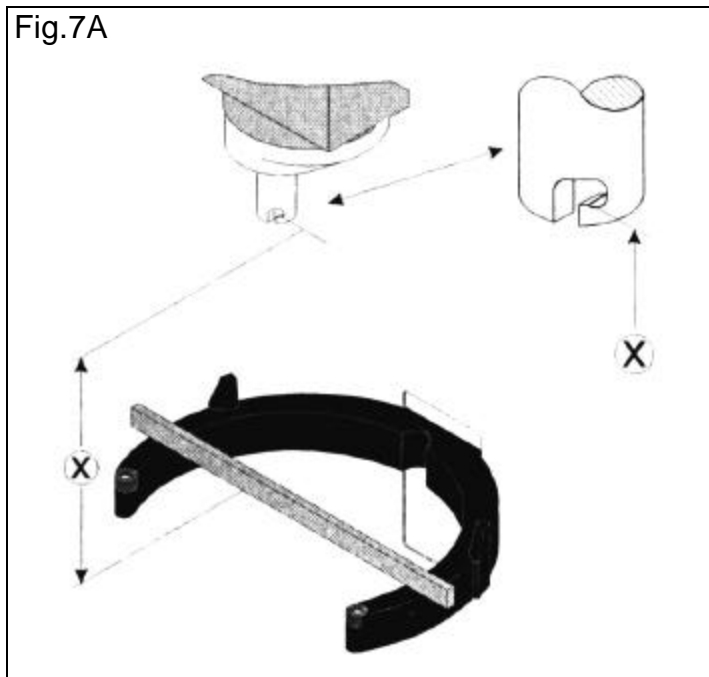
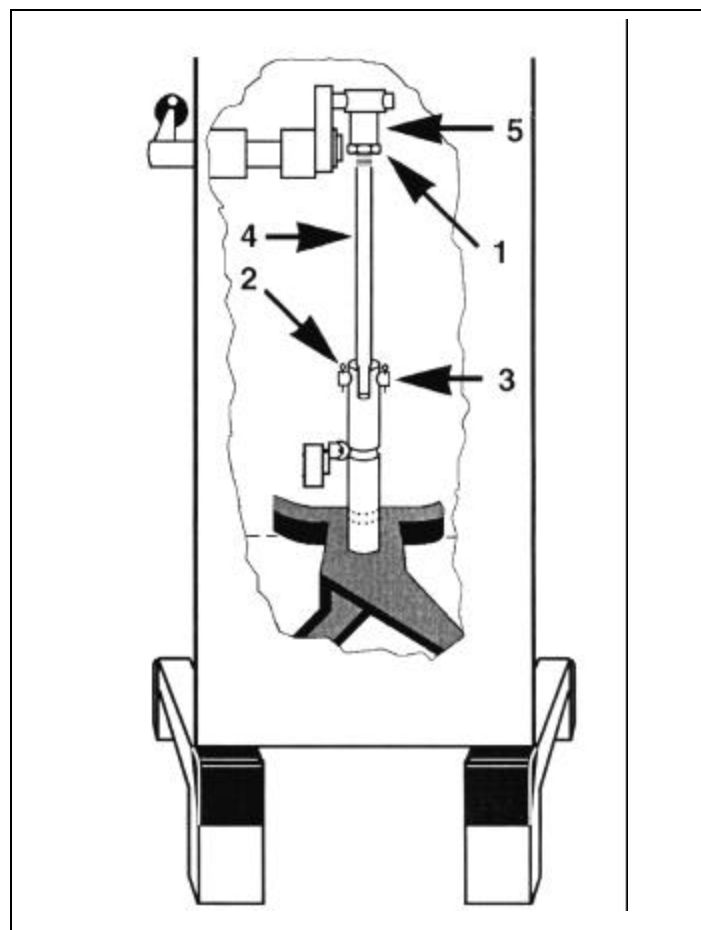
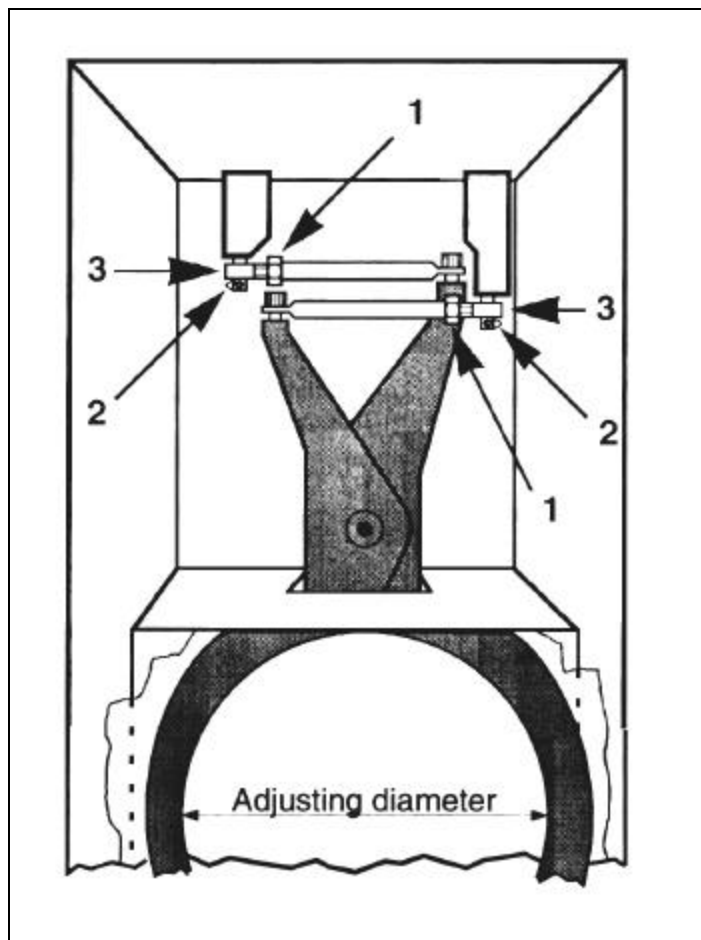

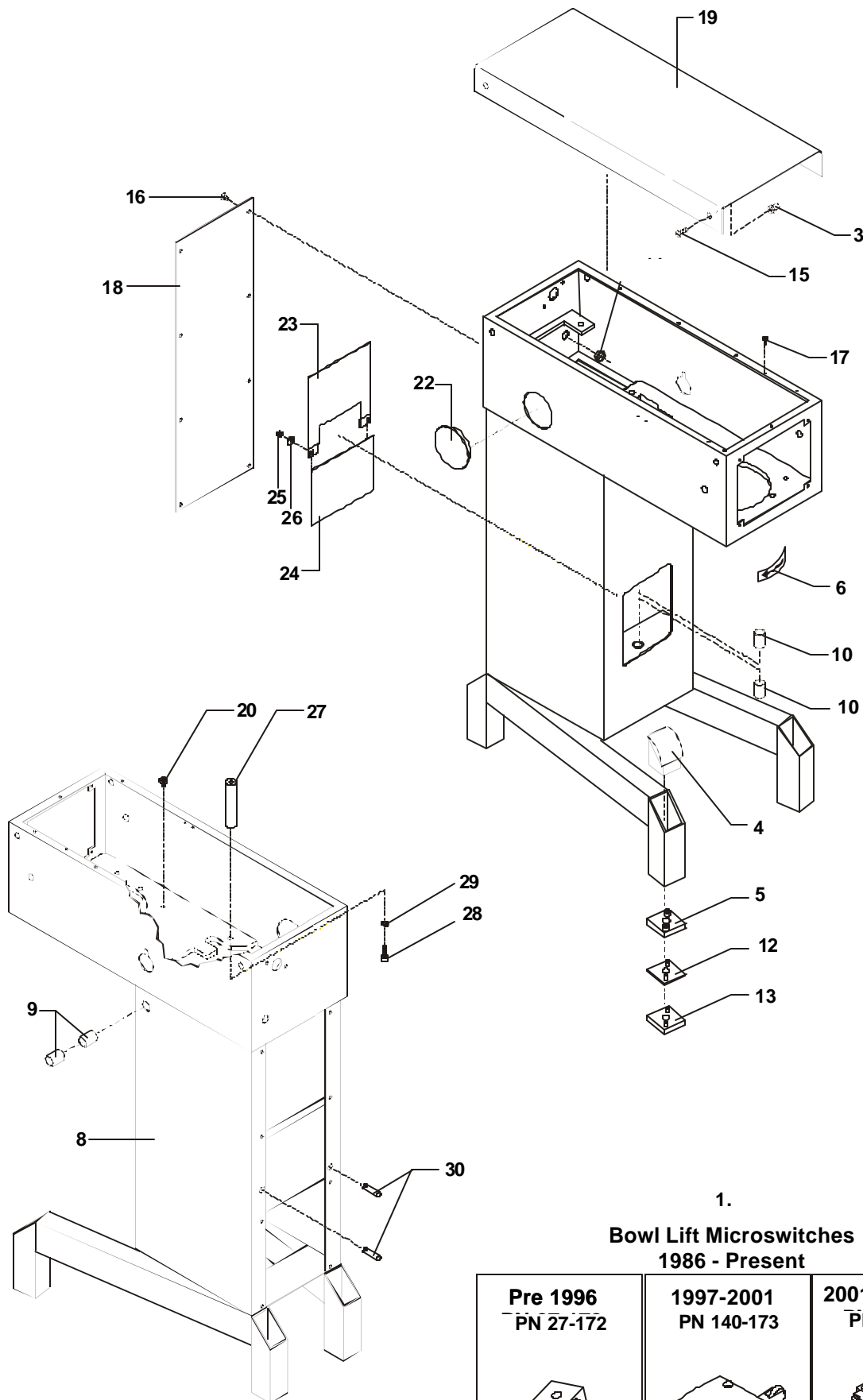

1.

**Bowl Lift Microswitches
1986 - Present**

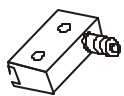
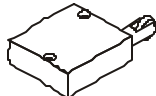
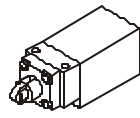
Pre 1996 PN 27-172	1997-2001 PN 140-173	2001- Present PN 81-173
		

MACHINE COLUMN

DESCRIPTION	PART NUMBER				
	W30(A)	W40(A)	W40P	W60(A)	W60P
1. Bowl Lift Microswitch	See Figure	See Figure	See Figure	See Figure	See Figure
2. Mounting Screws	STA 5270	STA 5270	STA 5270	STA 5270	STA 5270
3. Top Lid Threaded Bushing	STA 6580	STA 6580	STA 6580	STA 6580	STA 6580
4. Knee Pad	30N-212	30N-212	30N-212	60N-212	60N-212
5. Intermediate Piece 6 MM	30N-214.6	30N-214.6	30N-214.6	60N-214.6	60N-214.6
6. Indicator Arrow	15-245	15-245	15-245	15-245	15-245
8. Column	30N-22	30N-22	30N-22	60N-22	60N-22
9. Lift Lever Bushings	STA 2515	STA 2515	STA 2515	STA 2515	STA 2515
10. Bowl Arm Shaft Bushings	STA 2520	STA 2520	STA 2520	STA 2520	STA 2520
12. Intermediate Piece 3 MM	30N-214.3	30N-214.3	30N214.3	60N-214.3	60N-214.3
13. Foot	30N-213	30N-213	30N-213	60N-213	60N-213
15. Lid Screw	STA 5017	STA 5017	STA 5017	STA 5017	STA 5017
16. Access Plate Screw	STA 5080	STA 5080	STA 5080	STA 5080	STA 5080
17. Ground Screw	STA 5232	STA 5232	STA 5232	STA 5232	STA 5232
18. Rear Access Plate	27-22.7	27-22.7	27-22.7	60-22.7	60-22.7
19. Top Lid	27-21	27-21	27-21	60-21	60-21
20. Plug Button Rear Screen	31-306	31-306	31-306	31-306	31-306
22. Plug Button No Hub	15-73	15-73	15-73	15-73	15-73
23. Upper NSF Plate Cover	31-270	31-270	31-270	61-270	61-270
24. Lower NSF Plate Cover	31-271	31-271	31-271	61-271	61-271
25. Lock Nut NSF Plate	STA 5834	STA 5834	STA 5834	STA 5834	STA 5834
26. Washer	STA 6027	STA 6027	STA 6027	STA 6027	STA 6027
27. Motor Mount	31-148M4	31-148M4	31-148M4	61-148M4	61-148M4
28. Motor Mount Bolt	STA 5625	STA 5625	STA 5625	STA 5625	STA 5625
29. Lock Washer	STA 6056	STA 6056	STA 6056	STA 6056	STA 6056
30. Roll Pin	30-70.1	30-70.1	30-70.1	30-70.1	30-70.1

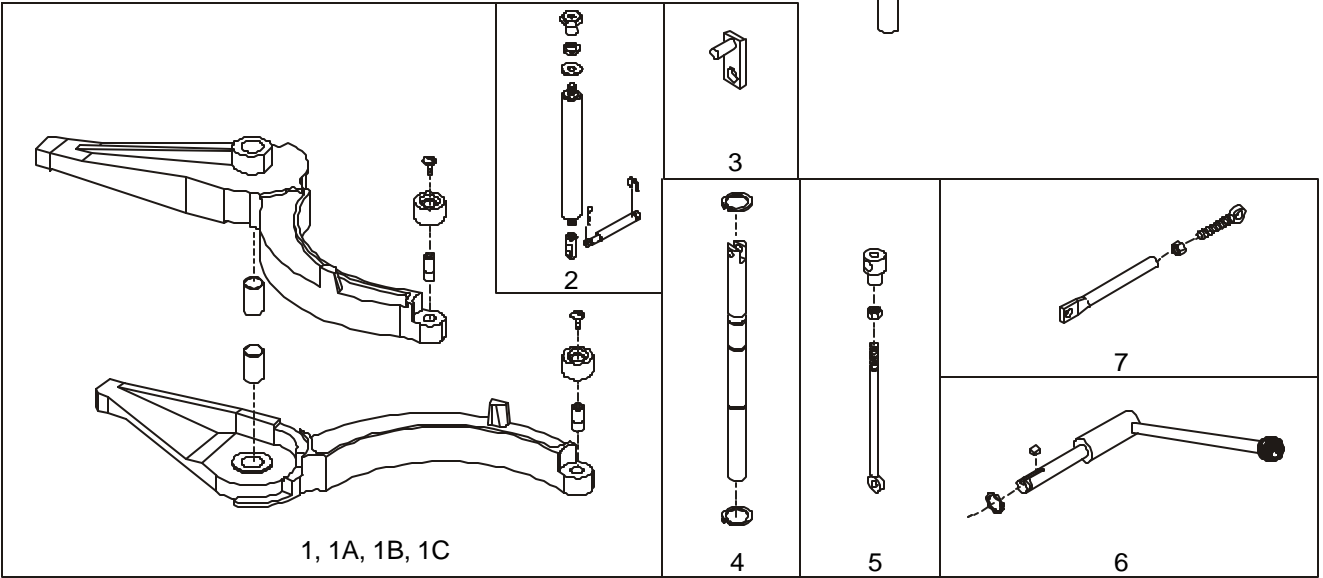
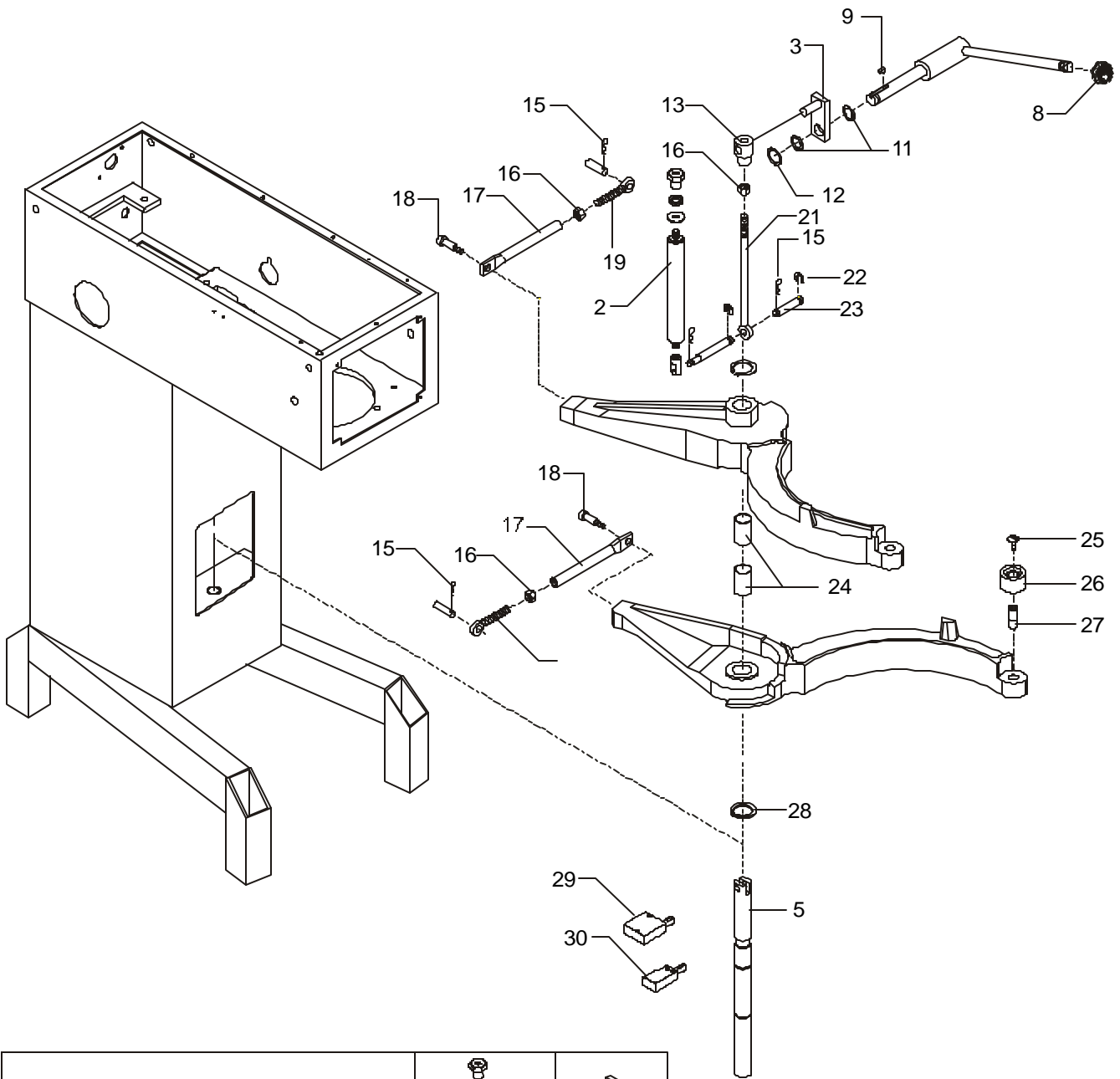

BOWL ARMS

FIG. NO.	DESCRIPTION	PART NUMBER				
		W30 (A)	W40 (A)	W40P	W60 (A)	W60P
1.	Bowl Arm Left (Pre 1993)	27-23	40-23	40-23	60-23	60-23
1A.	Bowl Arm Right (Pre 1993)	27-24	40-24	40-24	60-24	60-24
1B.	Bowl Arm Left	30N-23	40N-23	40N-23	60N-23	60N-23
1C.	Bowl Arm Right	30N-24	40N-24	40N-24	60N-24	60N-24
2.	Shock Absorber	40P-600M	40P-600M	40P-600M	60-600M	60-600M
3.	Crank Arm	27-63	27-63	27-63	60-63	60-63
4.	Bowl Arm Shaft	31-68	31-68	31-68	61-68	61-68
5.	Lifting Rod Assembly	30-65M	30-65M	30-65M	60-65M	60-65M,
6.	Bowl Lift Lever	27-62M	27-62M	27-62M	60-62M	60-62M
7.	Extension Tube Assembly	30-69M	30-69M	30-69M	60-69M	60-69M
8.	Red Ball	STA 3308	ST A3308	STA 3308	STA 3308	STA 3308
9.	Key B6 x 6 x 15	STA 2020	STA 2020	STA 2020	STA 2020	STA 2020
11.	Washer (s)	STA 6044	STA 6044	STA 6044	STA 6044	STA 6044
12.	Snap Ring	STA 3407	STA 3407	STA 3407	STA 3407	STA 3407
13.	Lifting Nut	15-65	15-65	15-65	15-65	15-65
15.	Cotter Pin	STA 6205	STA 6205	STA 6205	STA 6205	STA 6205
16.	JamNut	STA 5827	STA 5827	STA 5827	STA 5827	STA 5827
17.	Extension Tube	30-69	30-69	30-69	60-69	60-69
18.	Shoulder Bolt	STA 5690	STA 5690	STA 5690	STA 5690	STA 5690
19.	Eyebolt	30-80	30-80	30-80	30-80	30-80
21.	Lifting Bolt	27-83	27-83	27-83	60-83	60-83
22.	C-Clip	STA 3580	STA 3580	STA 3580	STA 3580	STA 3580
23.	Lift Bolt Pin	31-67	31-67	40P-67	31-67	31-67
24.	Bowl Arm Bushing	STA 2522	STA 2522	STA 2522	STA 2525	STA 2525
25.	Bowl Arm Roller Screw	STA 5088	STA 5088	STA 5088	STA 5088	STA 5088
26.	Bowl Arm Roller	31-128	31-128	31-128	31-128	31-128
27.	Bowl Arm Roller Shaft	31-127	31-127	31-127	31-127	31-127
28.	Snap Ring	STA 3467	STA 3467	STA 3467	STA 3460	STA 3460
29.	White Bowl Arm Microswitch	140-173	140-173	140-173	140-173	140-173
30.	Black Bowl Arm Microswitch	81-173	81-173	81-173	81-173	81-173

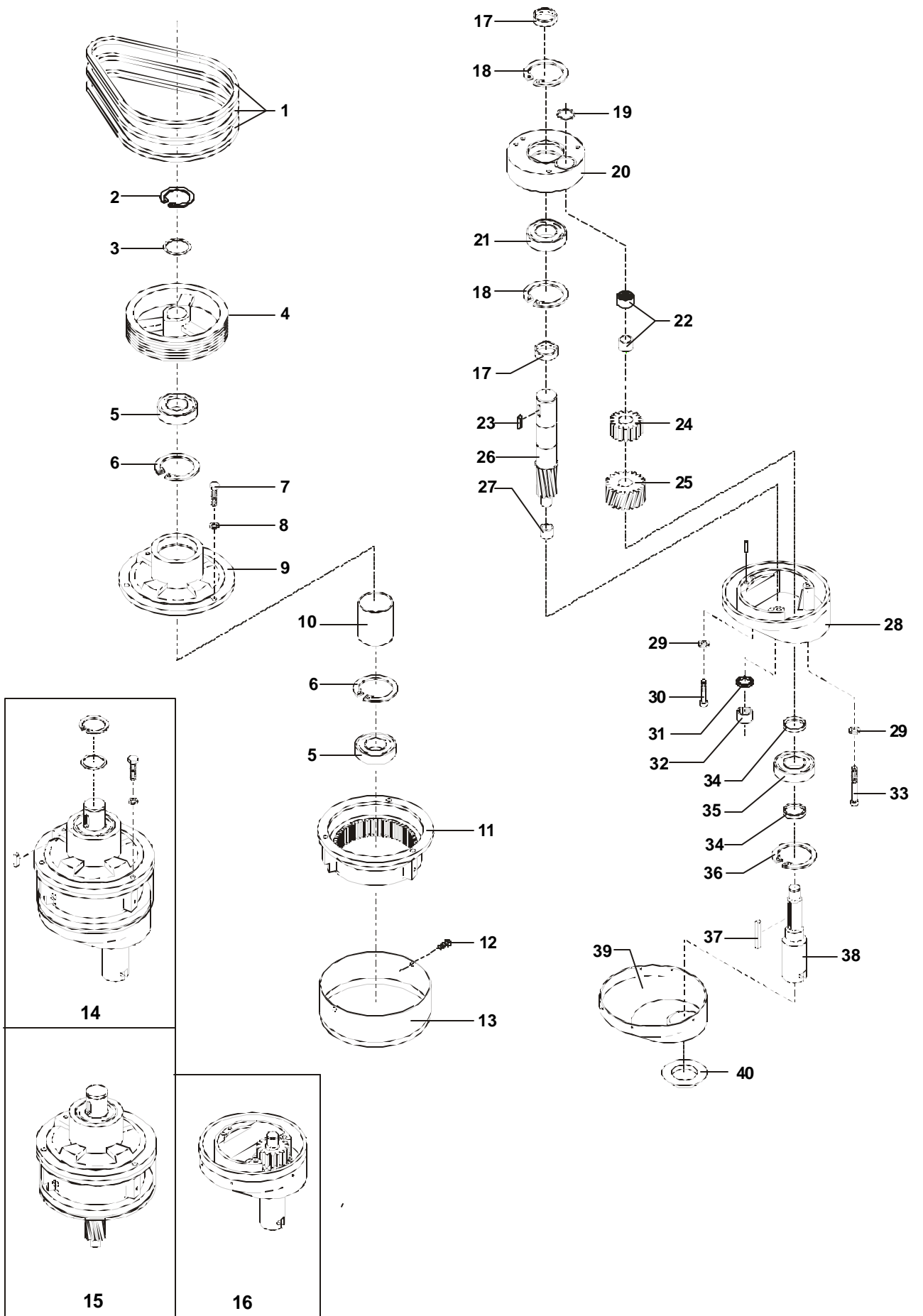

PLANETARY HEAD

FIG. NO.	DESCRIPTION	PART NUMBER per MODEL NUMBER				
		W30 (A)	W40 (A)	W40P	W60 (A)	W60P
1.	V-Belt (60 HZ) 3 per unit	40-90.1 (A29)	40-90.1 (A29)	40-90.1 (A29)	60-90.1 (A35)	60-90.1 (A35)
1A.	V-Belt (50 HZ) 3 per unit	40-90 (710LA)	40-90 (710LA)	40-90 (710LA)	60-90 (SPA 850)	60-90
1B.	V-Belt Single Cog Belt	N/A	N/A	40P-90.1	N/A	N/A
2.	Snap Ring	STA 3425	STA 3425	STA 3425	STA 3427	STA 3427
3.	Washer	STA 6043	STA 6043	STA 6043	STA 6047	STA 6047
4.	Planetary Pulley (60 HZ)	40-129A	40-129A	40-129A	60-129A	60-129A
4A.	Planetary Pulley (50 HZ)	40-129	40-129	40-129	60-129	60-129
4B.	Pulley Single Cog Belt	N/A	N/A	40P-129A	N/A	N/A
5.	Bearing	40-99	40-99	40-99	60-99	60-99
6.	Snap Ring	STA 3520	STA 3526	STA 3526	STA 3528	STA 3528
7.	Bolt M10 x 40 MM	STA 5346	STA 5346	STA 5346	STA 5346	STA 5346
8.	Washer	STA 6057	STA 6057	STA 6057	STA 6057	STA 6057
9.	Main Bearing	30-3	40-3	40-3	60-3	60-3
10.	Distance Tube	40-141	40-141	40-141	60-141	60-141
11.	Gear Wheel Rim	30-1	40-1	40-1	60-1	60-1
12.	Screw for Grey Cover	STA 5044	STA 5044	STA 5044	STA 5044	STA 5044
13.	Planetary Cover Grey Plastic	30-22.9P	40-22.9P	40-22.9P	60-22.9P	60-22.9P
14.	Planetary Head Assembly	30-2M	40-2M	40-2M	60-2M	60-2M
15.	Plan. Upper Half Assembly	30-3M	40-3M	40-3M	60-3M	60-3M
16.	Plan. Lower 1/2 Assembly	30-2.1M	40-2.1M	40-2.1M	60-2.1M	60-2.1M
17.	Distance Piece	40-34	40-34	40-34	60-37	60-37
18.	Snap Ring	STA 3520	STA 3520	STA 3520	STA 3523	STA 3523
19.	Snap Ring	STA 3472	STA 3474	STA 3474	STA 3474	STA 3474
20.	Eccentric Disc	30-36	40-36	40-36	60-36	60-36
21.	Bearing	40-100	40-100	40-100	60-100	60-100
22.	Needle Bearing	30-96	40-96	40-96	60-96	60-96
23.	Key 8 x 7 x 20 mm	STA 2030	STA 2030	STA 2030	STA 2030	STA 2030
24.	Upper Rim Pinion	30-31	40-31	40-31	60-31	60-31
25.	Lower Rim Pinion	30-32	40-32	40-32	60-32N	60-32N
26.	Main Shaft	30-30	40-30	40-30	60-30	60-30
27.	Bearing Race	See Item 32	See Item 32	See Item 32	See Item 32	See Item 32
28.	Lower Half Eccentric Head	30-2	40-2	40-2	60-2	60-2
29.	Lockwasher	STA 6055	STA 6057	STA 6057	STA 6057	STA 6057
30.	Bolt	STA 5640	STA 5645	STA 5645	STA 5646	STA 5646
31.	Seal	30-108R	40-108R	40-108R	60-108R	60-108R
32.	Needle Bearing w/ race	30-101	40-101	40-101	40-101	40-101
33.	Bolt	STA 5641	STA 5646	STA 5646	STA 5650	STA 5650
34.	Distance Piece	40-34	40-34	40-34	40-34	40-34
35.	Bearing	30-97	40-97	40-97	40-97	40-97
36.	Snap Ring	STA 3522	STA 3526	STA 3526	STA 3526	STA 3526
37.	Key(s)	STA 2038	STA 2040	STA 2040	STA 2034 (2)	STA 2034 (2)
38.	Bayonet Shaft	30-33D	40-33D	40-33D	60-33D	60-33D
39.	S/S Headcap	30-272	40-272	40-272	60-272	60-272
40.	Black Rubber Ring	30-209	40-209	40-209	60-209	60-209

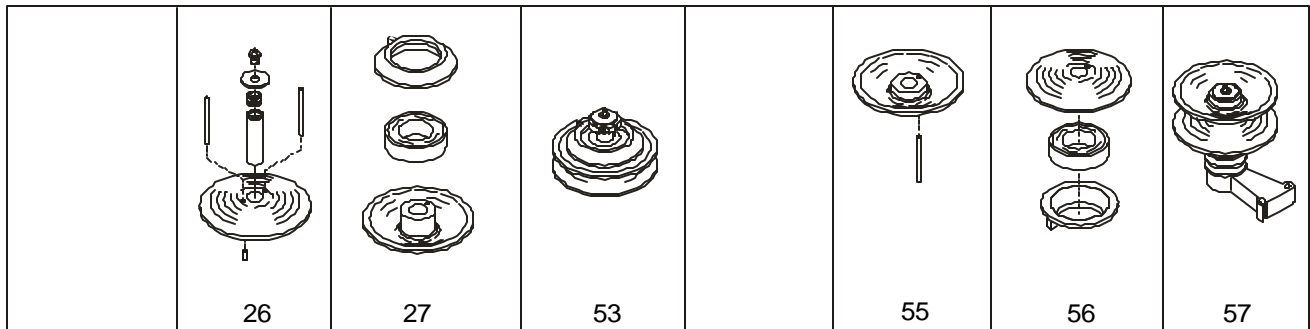
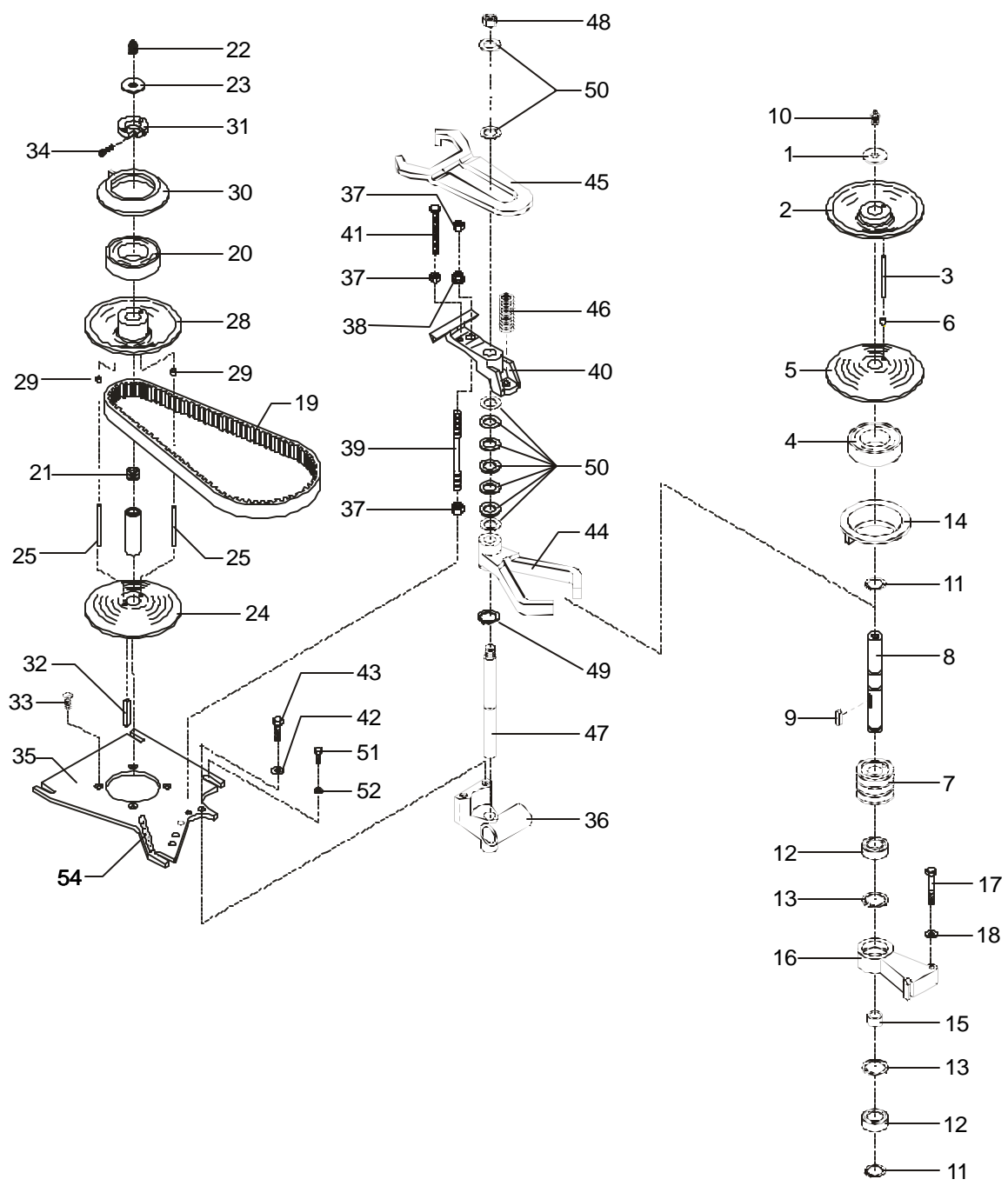

TRANSMISSION

FIG. NO.	DESCRIPTION	PART NUMBER per MODEL NUMBER				
		W30 (A)	W40 (A)	W40P	W60 (A)	W60P
1.	Washer	STA 6018	STA 6018	STA 6018	STA 6018	STA 6018
2.	Upper Pulley for Pedestal	15-13M	15-13M	15-13M	60-13M	60-13M
3.	Pin	30-285	30-285	30-285	60-285	60-285
4.	Bearing	15-103	15-103	15-103	15-103	15-103
5.	Lower Pulley	15-15M	15-15M	15-15M	60-15M	60-15M
6.	Bushing	STA 2505	STA 2505	STA 2505	STA 2505	STA 2505
7.	V-Belt Pulley	27-128	27-128	27-128	60-128	60-128
7A.	Single Cog Belt Pulley	N/A	N/A	40P-128	N/A	N/A
8.	Shaft	15-41	15-41	15-41	60-41	60-41
9.	Key	STA 2022	STA 2022	STA 2022	STA 2022	STA 2022
10.	Grease Nipple	STA 3220	STA 3220	STA 3220	STA 3220	STA 3220
11.	Snap Ring	STA 3410	STA 3410	STA 3410	STA 3410	STA 3410
12.	Bearing	27-102	27-102	27-102	27-102	27-102
13.	Snap Ring	STA 3514	STA 3514	STA 3514	STA 3514	STA 3514
14.	Fork Ring	15-17	15-17	15-17	15-17	15-17
15.	Distance Piece	15-143	15-143	15-143	15-143	15-143
16.	Arm for Bearing	30-6	30-6	30-6	30-6	30-6
17.	Bolt	STA 5348	STA 5348	STA 5348	STA 5348	STA 5348
18.	Washer	STA 6010	STA 6010	STA 6010	STA 6010	STA 6010
19.	Vari-Drive Belt	27-91	27-91	27-91	60-91	60-91
20.	Bearing	15-103	15-103	15-103	15-103	15-103
21.	Reducer	15-156	15-156	15-156	15-156	15-156
22.	Grease Nipple	STA 3220	STA 3220	STA 3220	STA 3220	STA 3220
23.	Washer	STA 6018	STA 6018	STA 6018	STA 6018	STA 6018
24.	Lower Motor Pully	See figure 26	See figure 26	See figure 26	See figure 26	See figure 26
25.	Pin for Motor Pulley	30-285	30-285	30-285	60-285	60-285
26.	Lower Motor Pulley Assembly	15-13.1M	15-13.1M	15-13.1M	60-13.1M	60-13.1M
27.	Upper Motor Pulley Assembly	15-15M	15-15M	15-15M	60-15.1M	60-15.1M
28.	Upper Pulley	See figure 27	See figure 27	See figure 27	See figure 27	See figure 27
29.	Bushing	STA 2505	STA 2505	STA 2505	STA 2505	STA 2505
30.	Fork Ring	15-17	15-17	15-17	15-17	15-17
31.	Clamping Ring	27-227	27-227	27-227	27-227	27-227
32.	Key	STA 2011	STA 2011	STA 2011	STA 2011	STA 2011
33.	Motor plate mount screw	STA 5018	STA 5018	STA 5018	STA 5018	STA 5018
34.	Screw	STA 5612	STA 5612	STA 5612	STA 5612	STA 5612
35.	Motor Mount Plate	60-61	60-61	60-61	60-61	60-61
36.	Rack Bracket	15-18	15-18	15-18	15-18	15-18
37.	Nut	STA 5815	STA 5815	STA 5815	STA 5815	STA 5815
38.	Washer Nut	STA 5895	STA 5895	STA 5895	STA 5895	STA 5895
39.	Stud Bolt Low Speed	30N-305	30N-305	30N-305	30N-305	30N-305
40.	Trestle	20-26	20-26	20-26	20-26	20-26
41.	Stop Bolt High Speed	STA 5444	STA 5444	STA 5444	STA 5444	STA 5444
42.	Washer	STA 6010	STA 6010	STA 6010	STA 6010	STA 6010
43.	Bolt	STA 5345	STA 5345	STA 5345	STA 5345	STA 5345
44.	Front Fork	27-16	27-16	27-16	27-16	27-16
45.	Rear Fork	20-19	20-19	20-19	20-19	20-19
46.	Spring	20-275	20-275	40P-275	40P-275	40P-275
47.	Rack	15-46	15-16	15-46	15-46	15-46
48.	Nut	STA 5815	STA 5815	STA 5815	STA 5815	STA 5815
49.	Snap Ring	STA 3407	STA 3407	STA 3407	STA 3407	STA 3407
50.	Belt Tension Washers	STA 6040	STA 6040	STA 6040	STA 6040	STA 6040
51.	Bolt	STA 5433	STA 5433	STA 5433	STA 5433	STA 5433
52.	Washer	STA 6026	STA 6026	STA 6026	STA 6026	STA 6026
53.	Motor Pulley Assembly	15-59M	15-59M	15-59M	60-59M	60-59M
55.	Upper Center Pulley Assembly	15-13M	15-13M	15-13M	60-13M	60-13M
56.	Lower Center Pulley Assembly	15-15M	15-15M	15-15M	60-15M	60-15M
57.	Center Pulley Assembly	27-6M	27-6M	27-6M	60-6M	60-6M

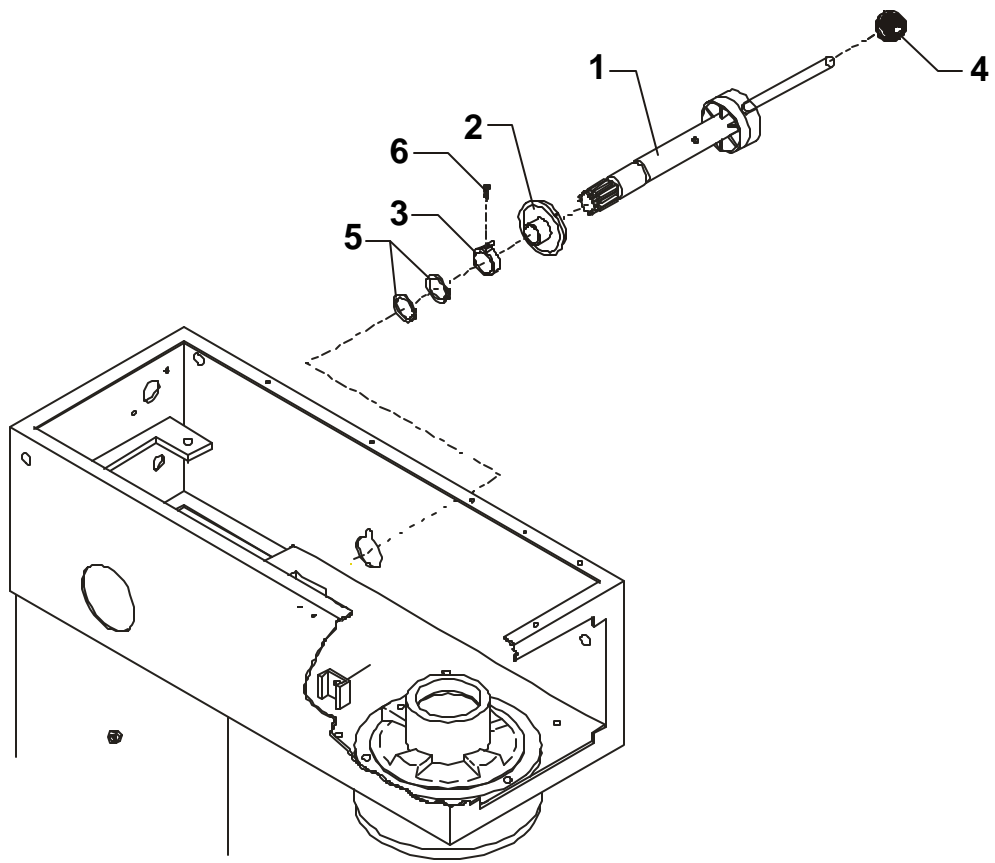

SPEED LEVER ASSEMBLY

FIG. NO.	DESCRIPTION	PART NUMBER per MODEL NUMBER				
		W30 (A)	W40 (A)	W40P	W60 (A)	W60P
1.	Speed Lever	30N-47M	40N-47M	40N-47M	60N-47M	60N-47M
2.	Disc with Arrow	30N-47.10	30N-47.10	30N-47.10	30N-47.10	30N-47.10
3.	White Clamp	30N-47.20	30N-47.20	30N-47.20	30N-47.20	30N-47.20
4.	Black Knob	STA 3306	STA 3306	STA 3306	STA 3306	STA 3306
5.	Snap Ring	STA 3414	STA 3414	STA 3414	STA 3414	STA 3414
6.	Screw	STA 5247	STA 5247	STA 5247	STA 5247	STA 5247

DRIVE SYSTEM FOR MODEL W40PI AND W60PI SPECIAL SINGLE SPEED TRANSMISSION

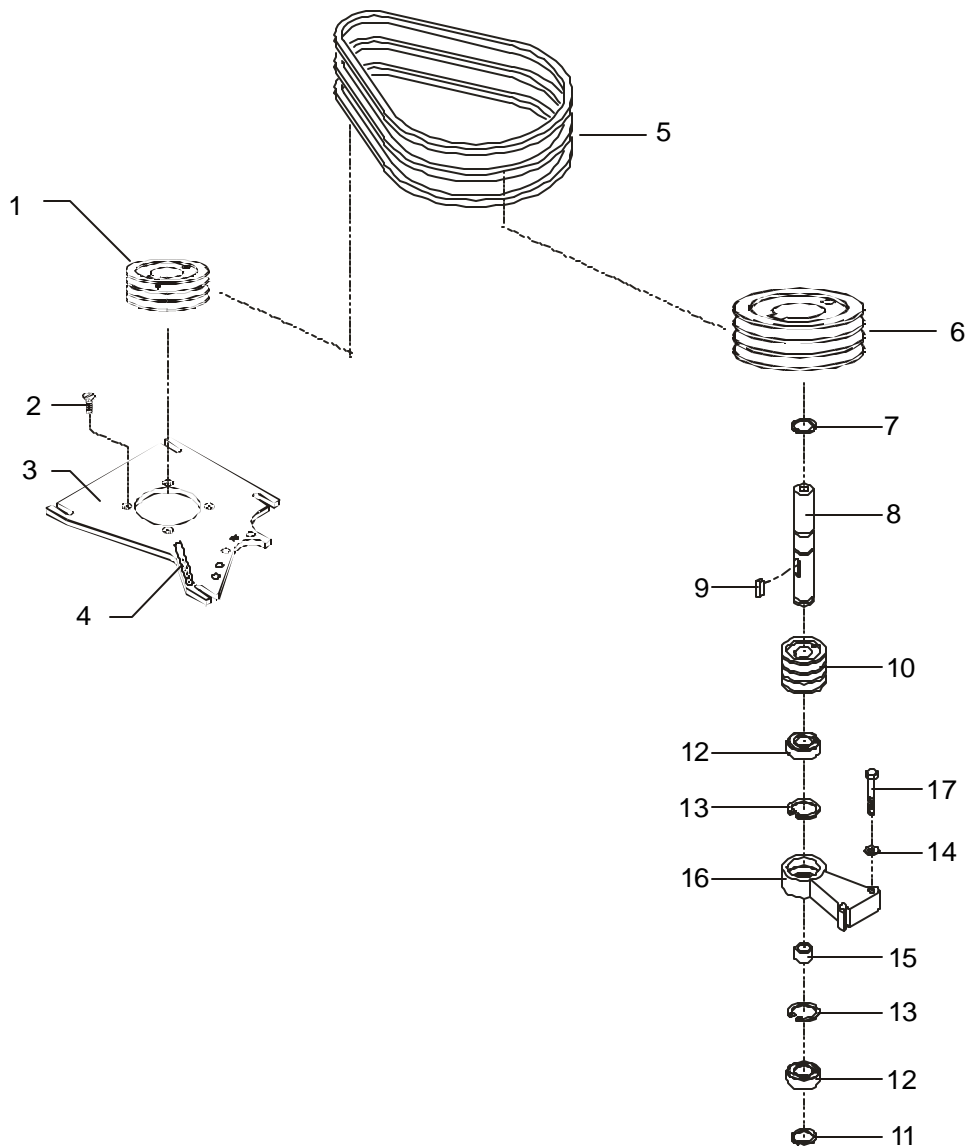

SINGLE SPEED TRANSMISSION

FIG. NO.	DESCRIPTION	PART NUMBER			
		W40PI	W60PI		
1.	Motor Pulley	33V315	33V315		
2.	Screw	STA 5018	STA 5018		
3.	Motor Plate	60-61	60-61		
4.	N/A	N/A	N/A		
5.	Belts	3VX400	3VX425		
6.	Center Pulley	33V80	33V80		
7.	Snap Ring	STA 3410	STA 3410		
8.	Pedestal Shaft	15-41	60-41		
9.	Key	STA 2022	STA 2022		
10.	Pulley	27-128	60-128		
11.	Snap Ring	STA 3410	STA 3410		
12.	Bearing	27-102	27-102		
13.	Snap Ring	STA 3514	STA 3514		
14.	Washer	STA 6010	STA 6010		
15.	Distance Tube	15-143	15-143		
16.	Arm for Bearing	30-6	30-6		
17.	Bolt	STA 5348	STA 5348		

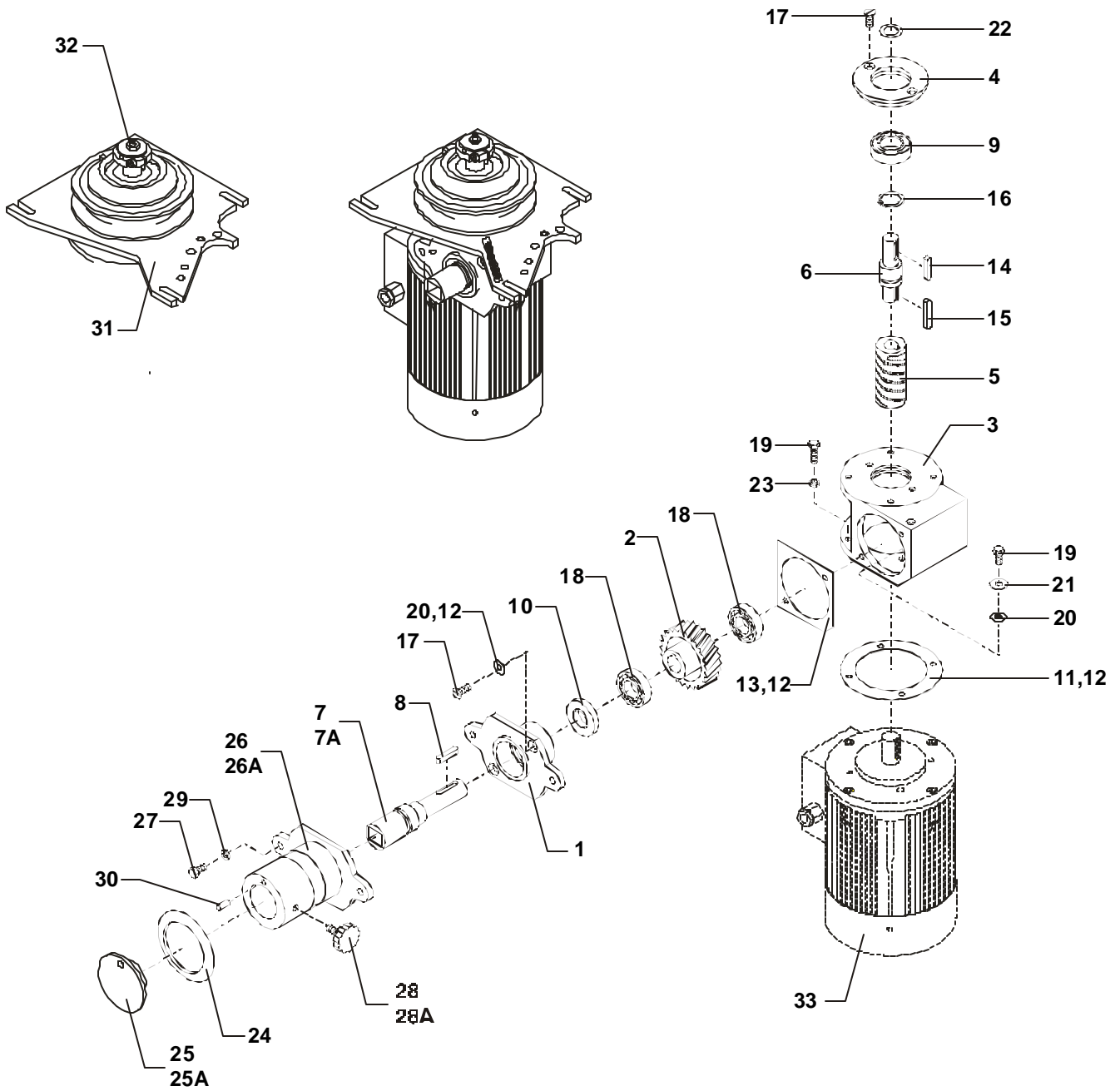

IDENTIFYING A #17 HUB VERSUS A #12 HUB

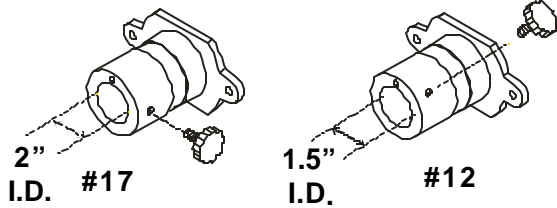

THIS AFFECTS ITEM NUMBERS:

- 7, 7A
- 25, 25A
- 26, 26A
- 28, 28A

34 AND 35

PLEASE DETERMINE HUB SIZE BEFORE ORDERING PARTS

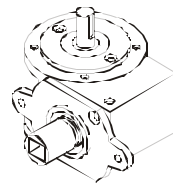

34

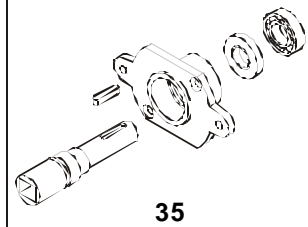

35



36

ATTACHMENT DRIVE GEARBOX

FIG. NO.	DESCRIPTION	PART NUMBER				
		W30 (A)	W40 (A)	W40P	W60 (A)	W60P
1.	Bearing Hub	15-5	15-5	15-5	15-5	15-5
2.	Wormwheel	20-9	20-9	20-9	20-9	20-9
3.	Gear Case	15-10	15-10	15-10	15-10	15-10
4.	Gear Case Cover	15-11	15-11	15-11	15-11	15-11
5.	Worm Gear	20-49	20-49	20-49	20-49	20-49
6.	Gear Shaft	20-52	20-52	20-52	20-52	20-52
7.	Attachment Drive Shaft # 17	15-50	15-50	15-50	15-50	15-50
7A.	Attachment Drive Shaft # 12	30-50	30-50	30-50	30-50	30-50
8.	Key	STA 2032	STA 2032	STA 2032	STA 2032	STA 2032
9.	Bearing	20-104	20-104	20-104	20-104	20-104
10.	Seal	20-107	20-107	20-107	20-107	20-107
11.	Gasket	Use RTV Silicone	Use RTV	Use RTV	Use RTV	Use RTV
12.	Gasket	Use RTV Silicone	Use RTV	Use RTV	Use RTV	Use RTV
13.	Gasket	Use RTV Silicone	Use RTV	Use RTV	Use RTV	Use RTV
14.	Key	STA 2007	STA 2007	STA 2007	STA 2007	STA 2007
15.	Key	STA 2011	STA 2011	STA 2011	STA 2011	STA 2011
16.	Snap Ring	STA 3410	STA 3410	STA 3410	STA 3410	STA 3410
17.	Screw	STA 5018	STA 5018	STA 5018	STA 5018	STA 5018
18.	Bearing	15-105	15-105	15-105	15-105	15-105
19.	Bolt	STA 5433	STA 5433	STA 5433	STA 5433	STA 5433
20.	Seal Washer	STA 5908	STA 5908	STA 5908	STA 5908	STA 5908
21.	Washer	STA 6020	STA 6020	STA 6020	STA 6020	STA 6020
22.	Washer	STA 6054	STA 6054	STA 6054	STA 6054	STA 6054
23.	Lock Washer	STA6056	STA6056	STA6056	STA6056	STA6056
24.	Rubber Ring	15-211	15-211	15-211	15-211	15-211
25.	End Cover #17	15-214	15-214	15-214	15-214	15-214
25A.	End Cover #12	312C	312C	312C	312C	312C
26.	Hub #17	15-8	15-8	15-8	15-8	15-8
26A.	Hub #12	30-8	30-8	30-8	30-8	30-8
27.	Bolt	STA 5322	STA 5322	STA 5322	STA 5322	STA 5322
28.	Thumbscrew #17	STA 5561	STA 5561	STA 5561	STA 5561	STA 5561
28A.	Thumbscrew #12	4R-125	4R-125	4R-125	4R-125	4R-125
29.	Washer	STA 6056	STA 6056	STA 6056	STA 6056	STA 6056
30.	Roll Pin #17 Hub Only	STA 6316	STA 6316	STA 6316	STA 6316	STA 6316
31.	Motor Mount Plate	60-61	60-61	60-61	60-61	60-61
32.	Motor Pulley Assembly	15-59M	15-59M	15-59M	60-59M	60-59M
33.	Motor 3HP 1 phase 115V-230V	60-85.62	60-85.62	60-85.62	60-85.62	N/A
33A.	Motor 3HP 3 phase 208V-240V	60-85.52	60-85.52	60-85.52	60-85.52	N/A
33B.	Motor 3HP 3 phase 480V	60-85.52	60-85.52	60-85.52	60-85.52	N/A
33C.	Motor 4HP 3 phase 208V-240V	N/A	N/A	N/A	N/A	100-85.50
33D.	Motor 4HP 3 phase 480V	N/A	N/A	N/A	N/A	100-85.10
34.	Att. Drive Assembly #17	30-10.5M	30-10.5M	30-10.5M	30-10.5M	30-10.5M
34A.	Att. Drive Assembly #12	30-10.6M	30-10.6M	30-10.6M	30-10.6M	30-10.6M
35.	Att. Shaft Assembly #17	15-5M	15-5M	15-5M	15-5M	15-5M
35A.	Att. Shaft Assembly #12	30-5M	30-5M	30-5M	30-5M	30-5M
36.	Gear Cover Assembly	15-11M	15-11M	15-11M	15-11M	15-11M

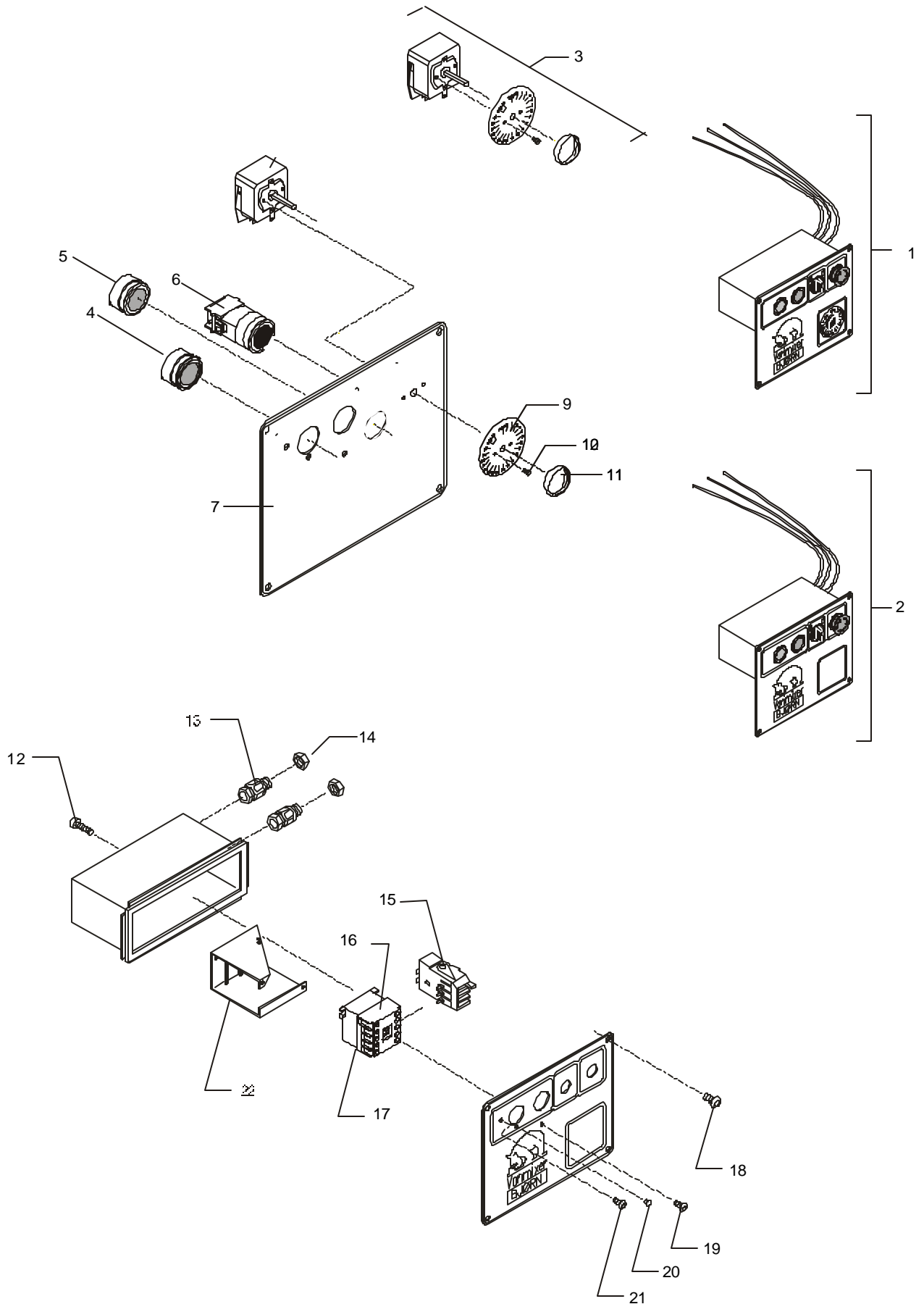

ELECTRICAL PANEL 1985 - JUNE 1998

FIG. NO.	DESCRIPTION	PART NUMBER				
		W30 (A)	W40 (A)	W40P	W60 (A)	W60P
1.	Electrical Control Assembly 208-240V 3 Phase	40P-149M	40P-149M	40P-149M	40P-149M	40P-149M
2.	Electrical Control Assembly 230V 1 Phase	30-149M	30-149M	30-149M	30-149M	30-149M
3.	Timer Assembly 208-240V	30-188.15M	30-188.15M	30-188.15M	30-188.15M	30-188.15M
3A.	Timer Assembly 480V	27-188.1	27-188.1	27-188.1	27-188.1	27-188.1
4.	Start Button Green	30-174	30-174	30-174	30-174	30-174
5.	Stop Button Orange	30-175	30-175	30-175	30-175	30-175
6.	Pilot Light	27-186	27-186	27-186	27-186	27-186
7.	Front Panel	27-149	27-149	27-149	27-149	27-149
8.	N/A	N/A	N/A	N/A	N/A	N/A
9.	Timer Scale	30-190	30-190	30-190	30-190	30-190
10.	Screw	STA 5232	STA 5232	STA 5232	STA 5232	STA 5232
11.	Timer Knob	30-189	30-189	30-189	30-189	30-189
12.	Screw	STA 5627	STA 5627	STA 5627	STA 5627	STA 5627
13.	Cable Inlet	STA 3000	STA 3000	STA 3000	STA 3000	STA 3000
14.	Nut	STA 3010	STA 3010	STA 3010	STA 3010	STA 3010
15.	Thermal Overload 3 Ph. 220V	20-88.22	20-88.22	20-88.22	20-88.22	20-88.24
15A.	Thermal Overload 3 Ph. 480V	20-88.21	20-88.21	20-88.21	20-88.21	20-88.21
15B.	Thermal Overload 1 Ph. 230V	20-88.24	20-88.24	20-88.24	20-88.24	N/A
15C.	Thermal Overload 1 Ph. 115V	100-88.30	100-88.30	100-88.30	100-88.30	N/A
16.	Auxiliary Start Switch	20-88.45	20-88.45	20-88.45	20-88.45	20-88.45
17.	Contactor 3 Ph. 220V	20-88.4	20-88.4	20-88.4	20-88.4	100-88.5
17A.	Contactor 3 Ph. 480V	20-88.91	20-88.91	20-88.91	20-88.91	20-88.91
17B.	Contactor 1 Ph. 230V	100-88.5	100-88.5	100-88.5	100-88.5	N/A
17C.	Contactor 1 Ph. 115V	100-88.4	N/A	N/A	N/A	N/A
18.	Screw	STA 5080	STA 5080	STA 5080	STA 5080	STA 5080
19.	Screw	STA 5614	STA 5614	STA 5614	STA 5614	STA 5614
20.	Plug Button	STA 6131	STA 6131	STA 6131	STA 6131	STA 6131
21.	Screw	STA 5614	STA 5614	STA 5614	STA 5614	STA 5614
22.	Contactor Bracket	27-152	27-152	27-152	27-152	27-152

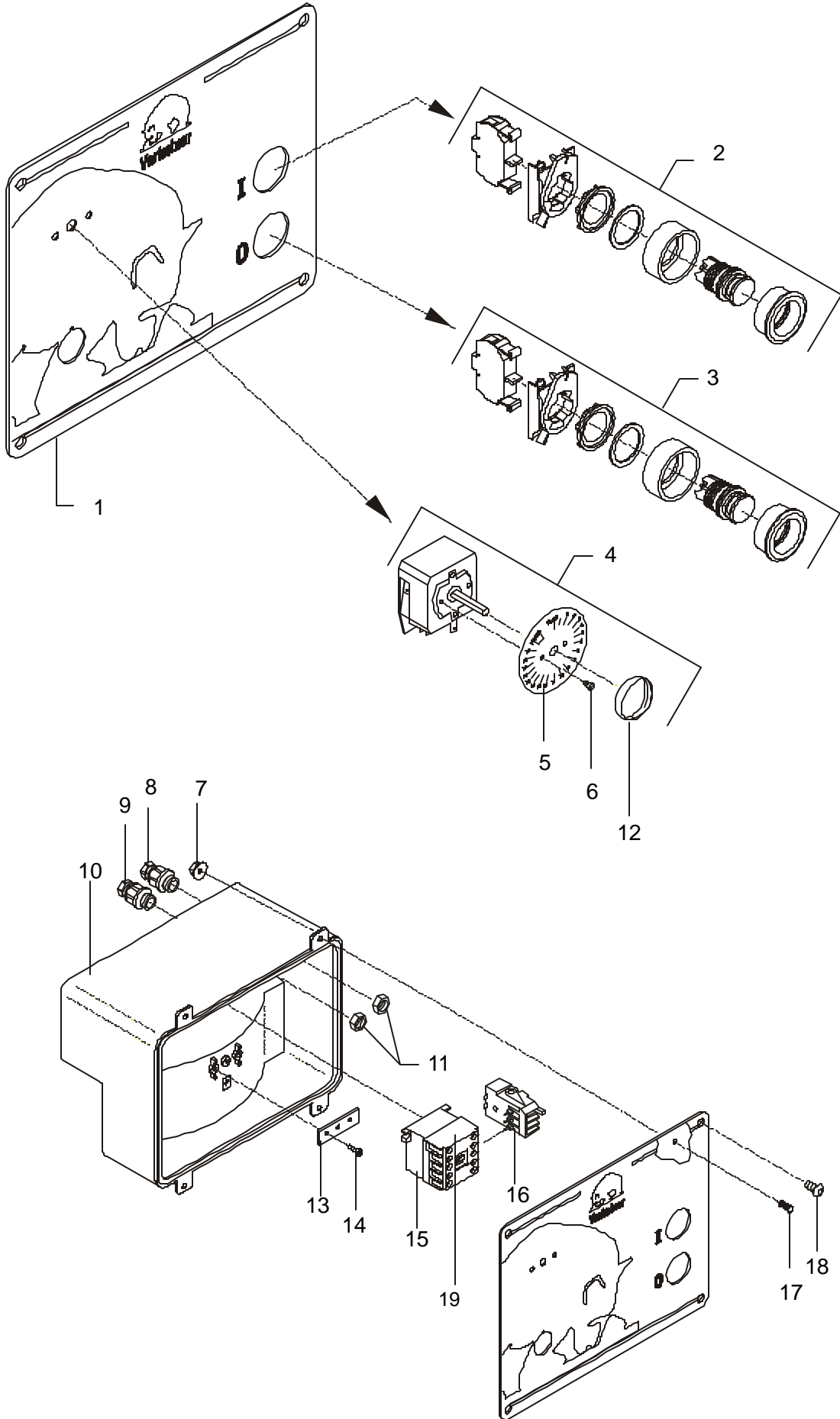

ELECTRICAL PANEL JULY 1998 - PRESENT

FIG. NO.	DESCRIPTION	PART NUMBER				
		W30 (A)	W40 (A)	W40P	W60 (A)	W60P
1.	Front Panel	30N-149	30N-149	30N-149	30N-149	30N-149
2.	Start Switch Assembly	31-174.2	31-174.2	31-174.2	31-174.2	31-174.2
3.	Stop Switch Assembly	31-174.3	31-174.3	31-174.3	31-174.3	31-174.3
4.	Timer Assembly 220V	30-188.15	30-188.15	30-188.15	30-188.15	30-188.15
5.	Timer Scale	30-190	30-190	30-190	30-190	30-190
6.	Screw	STA 5232	STA 5232	STA 5232	STA 5232	STA 5232
7.	Nut	STA 5897	STA 5897	STA 5897	STA 5897	STA 5897
8.	Cable Inlet	STA 3000	STA 3000	STA 3000	STA 3000	STA 3000
9.	Cable Inlet	STA 3000	STA 3000	STA 3000	STA 3000	STA 3000
10.	Cover	31-152	31-152	31-152	31-152	31-152
11.	Nut	STA 3010	STA 3010	STA 3010	STA 3010	STA 3010
12.	Timer Knob	30-189	30-189	30-189	30-189	30-189
13.	Grounding Clamp	31-457	31-457	31-457	31-457	31-457
14.	Screw	STA 5232	STA 5232	STA 5232	STA 5232	STA 5232
15.	Contactors 3 Ph. 220V	20-88.4	20-88.4	20-88.4	20-88.4	100-88.5
15A.	Contactors 3 Ph. 480V	20-88.91	20-88.91	20-88.91	20-88.91	20-88.91
15B.	Contactors 1 Ph. 230V	100-88.5	100-88.5	100-88.5	100-88.5	N/A
15C.	Contactors 1 Ph. 115V	N/A	N/A	N/A	N/A	N/A
16.	Thermal Overload 3 Ph. 220V	20-88.22	20-88.22	20-88.22	20-88.22	20-88.24
16A.	Thermal Overload 3 Ph. 480V	20-88.21	20-88.21	20-88.21	20-88.21	20-88.21
16B.	Thermal Overload 1 Ph. 230V	20-88.24	20-88.24	20-88.24	20-88.24	N/A
16C.	Thermal Overload 1 Ph. 115V	100-88.30	100-88.30	100-88.30	100-88.30	N/A
17.	Screw	STA 6483	STA 6483	STA 6483	STA 6483	STA 6483
18.	Screw	STA 5080	STA 5080	STA 5080	STA 5080	STA 5080
19.	Auxiliary Start Switch	20-88.47	20-88.47	20-88.47	20-88.47	20-88.47

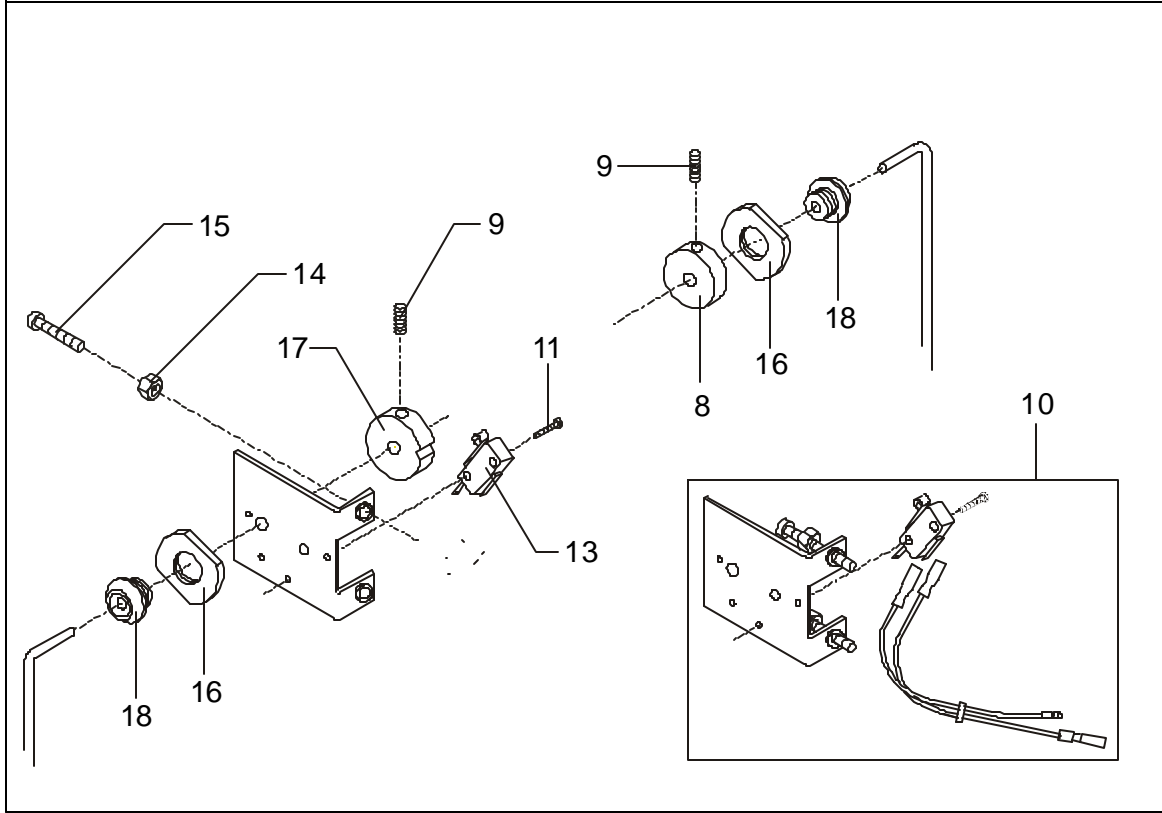

1

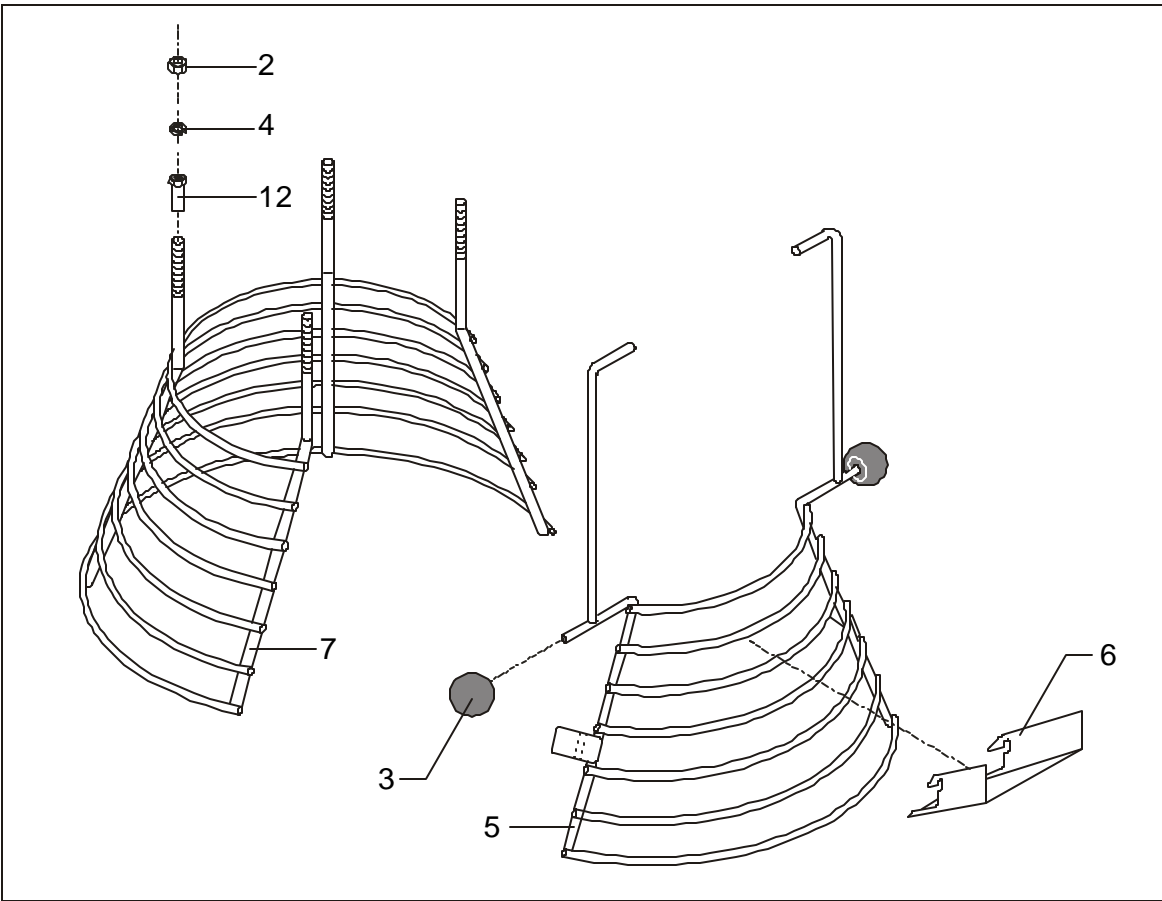

BOWL SCREEN 1993 - PRESENT

FIG. NO.	DESCRIPTION	PART NUMBER				
		W30 (A)	W40 (A)	W40P	W60 (A)	W60P
1.	Bowl Screen Kit	225/30A	225/40A	225/40A	225/60	225/60
2.	Nut	STA 5810	STA 5810	STA 5810	STA 5810	STA 5810
3.	Knob	STA 3307	STA 3307	STA 3307	STA 3307	STA 3307
4.	Lock Washer	STA 6056	STA 6056	STA 6056	STA 6056	STA 6056
5.	Bowl Screen Front	225/30F	225/40F	225/40F	225/60F	225/60F
6.	Chute	56G20-280	56G20-280	56G20-280	56G20-280	56G20-280
7.	Bowl Screen Rear	225/30R	225/40R	225/40R	225/60R	225/60R
8.	Cam	56SN30-23	56SN30-23	56SN30-23	56SN30-23	56SN30-23
9.	Set Screw	STA 5665	STA 5665	STA 5665	STA 5665	STA 5665
10.	Bracket Assembly	56P30-15	56P30-15	56P30-15	56P30-15	56P30-15
11.	Screw	STA 5251	STA 5251	STA 5251	STA 5251	STA 5251
12.	Nut	56G30-26	56G30-26	56G30-26	56G30-26	56G30-26
13.	Microswitch	56SN20-30	56SN20-30	56SN20-30	56SN20-30	56SN20-30
14.	Jam Nut	STA 5819	STA 5819	STA 5819	STA 5819	STA 5819
15.	Screw	STA 5250	STA 5250	STA 5250	STA 5250	STA 5250
16.	Nut for Bushing	56SN30-24	56SN30-24	56SN30-24	56SN30-24	56SN30-24
17.	Notched Cam	56SN30-22	56SN30-22	56SN30-22	56SN30-22	56SN30-22
18.	Body Bushing	56SN30-21	56SN30-21	56SN30-21	56SN30-21	56SN30-21



Varimixer

Installation and Cleaning Instructions for
Slicer, Shredder, Grater and Dicer Attachments

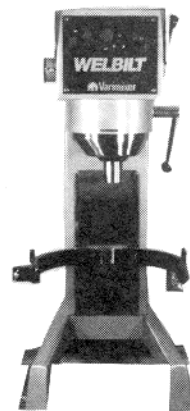

SLICER KNIFE AND SHREDDER/GRATER INSTALLATION

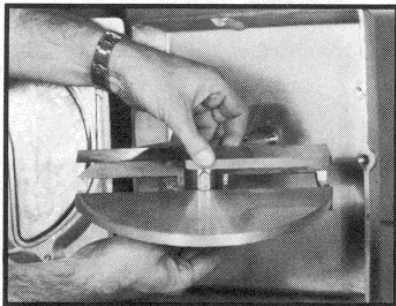
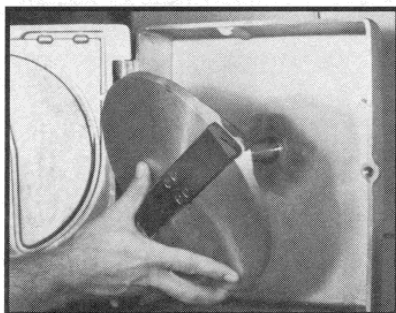

FIGURE 1

WARNING: USE EXTREME CAUTION WHEN HANDLING KNIFE ASSEMBLY. CUTTING EDGES ARE VERY SHARP AND INJURY MAY RESULT.



ASSEMBLY

FIGURE 2 (a)

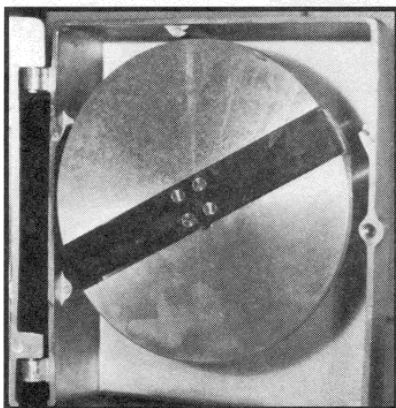

FIGURE 2 (b)

STEP 1.

Insert the knife assy. F into the slicer disc E. [Figure 1]

STEP 2.

Install the adjustment ring on the knife assy. shaft by turning the ring counterclockwise. Snug hand tight.

NOTE: Use care when starting threads on ring and knife assy. Threads are very fine and left hand. Care should be taken so as not to crossthread.

REFERENCE FIGURE 1 (Page 4) AND FIGURE 4 (Page 2).

STEP 3.

To adjust the thickness of the slices, rotate the adjustment ring clockwise for thicker slices and counterclockwise for thinner slices. After desired adjustment is reached, snug the nylon lock screw. **DO NOT OVER TIGHTEN!**

NOTE: Soft Vegetable Slicer (M) is installed in the same manner as the Shredder. [Figure 3]

STEP 4.

Install the Knife assy. over the shaft of the Rear Housing Assy.

STEP 5.

Close Front housing assy. (door) and hand tighten Thumb Screw.

NOTE: Shredders and Graters are installed as in Step 4 above. They need no adjustment.

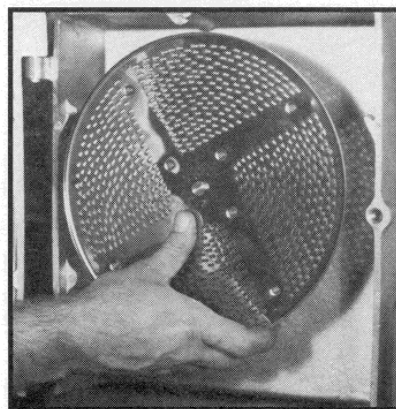
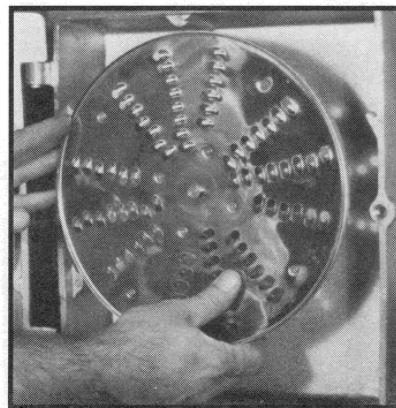

FIGURE 3

CLEANING INSTRUCTIONS

All attachments and accessories should be Hand Washed in a mild detergent and warm water.

DO NOT WASH IN DISHWASHER!

NOTE: Lubrication of the rear housing shaft and bushing with a few drops of light weight oil prior to each use.

NOTE: Knife blade should be coated with vegetable oil after washing to prevent oxidation. Knife blade is made from a high carbon steel and cannot be sharpened.

VARIMIXER SLICER/SHREDDER ATTACHMENTS

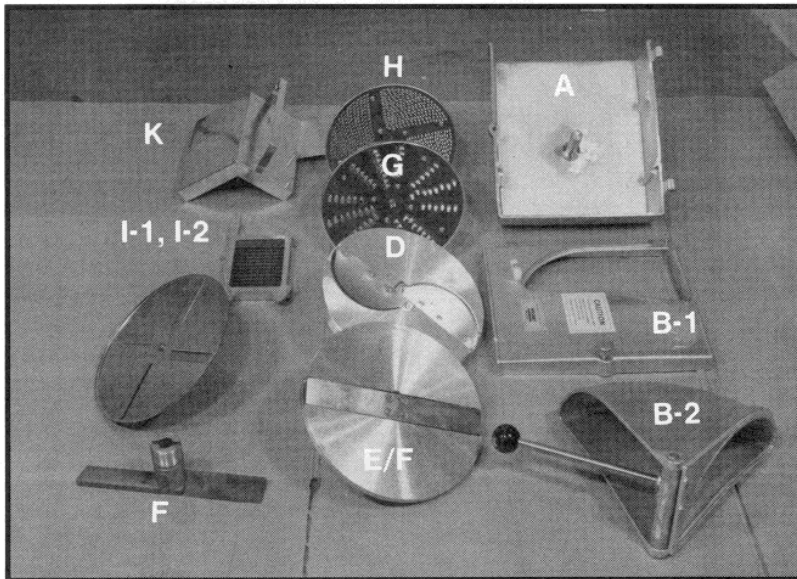

1. A – No. 17 Housing Assy. (Rear)
2. B-1 – No. 17 Housing Assy. (Front)
3. B-2 – Trough Assy.
4. E/F – Slicer Knife & Disc. Assy.
- 4a. F – Knife Assy.
5. G – Shredder
6. D – Soft Vegetable Slicer Assy.
7. H – Grater
8. K – Separating skid
9. I-1 – French Fry Grid or Dicer

HOUSING AND DICER GRID INSTALLATION INSTRUCTIONS

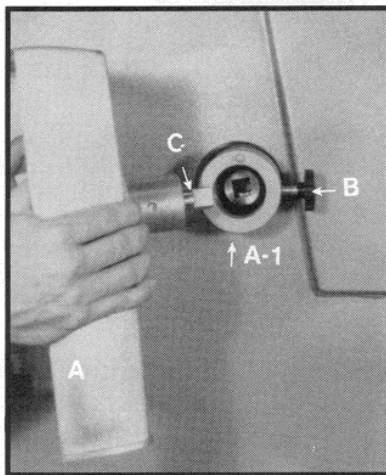

FIGURE 2

STEP 1.

Remove Accessory Drive Dust Cover

STEP 2.

Insert shaft of Housing rear (A) in the Accessory Drive (A1). Ensure that Shaft (C) is aligned with the notch in the rear housing. Rotation of shaft may be necessary to engage drive. Secure by tightening knob [FIGURE 2 (B)]

STEP 3.

Insert Dicer (I1) or French Fry Grid as shown. [FIGURE 3]

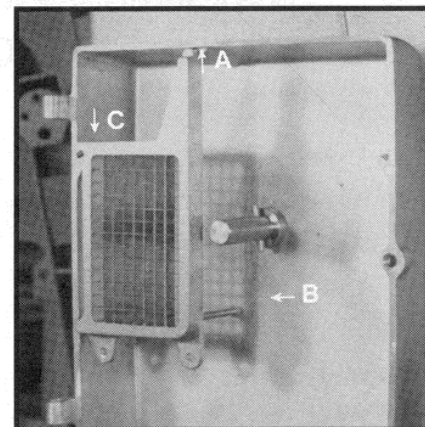

FIGURE 3

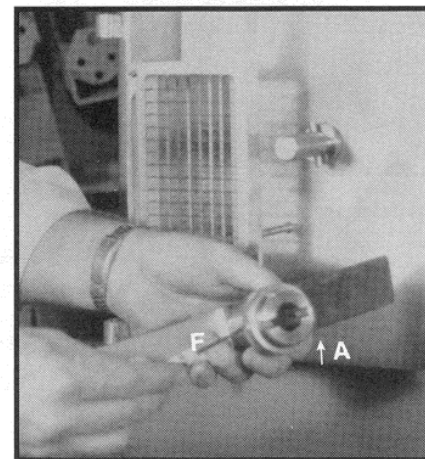

FIGURE 4

STEP 4.

CAUTION: Knife is sharp. Remove F — Knife Assy. from E — Disc by loosening the Nylon Lock Screw and removing the adjustment ring. [Figure 4] [Note: Threads are left hand.] Reinstall adjustment ring onto Knife assy. and SNUG nylon lock screw when proper adjustment is made. [See instructions for knife adjustment later in this brochure.]

Insert Knife Assy. (F) as follows:

1. Loosen nylon lock screw. [Figure 4(A)]
 2. Rotate blade adjustment ring counterclockwise until the notch is completely visible on shaft.
 3. Snug nylon lock screw (A).
- DO NOT OVERTIGHTEN!**
4. Insert Knife Assy. (F) onto drive shaft of housing rear as shown. [Figure 5]

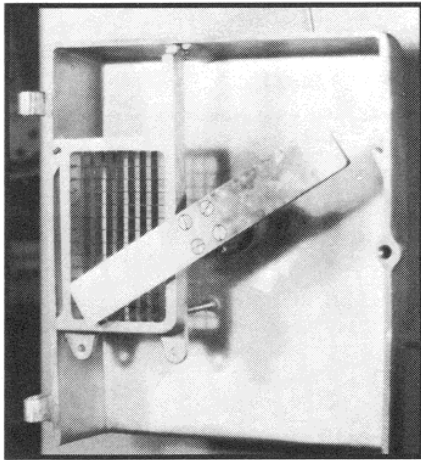

FIGURE 5

STEP 5.

Install separator skid (K) by inserting the 2 pins (shown) into holes on bottom of Cuber (I-2) or French Fry grid. [Figure 6]

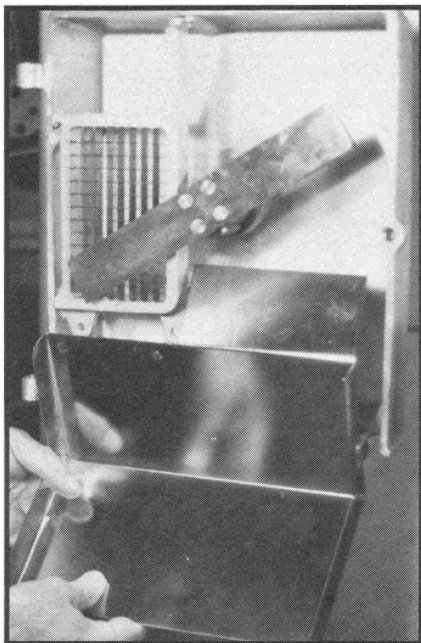

FIGURE 6

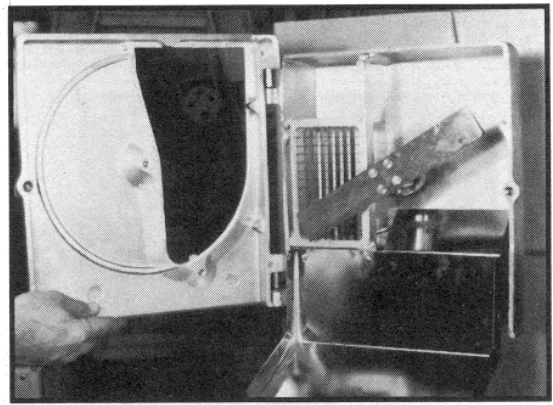

FIGURE 7

STEP 6.

Install housing front or door (B-1) onto hinge pins. Close and fasten with thumb screw.

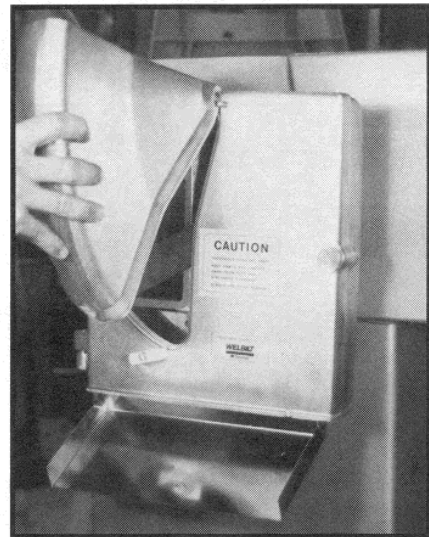

FIGURE 8

STEP 7.

Install Trough (B-2) as shown. [Figure 8]

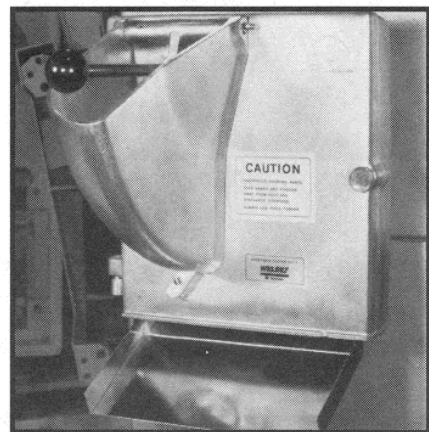
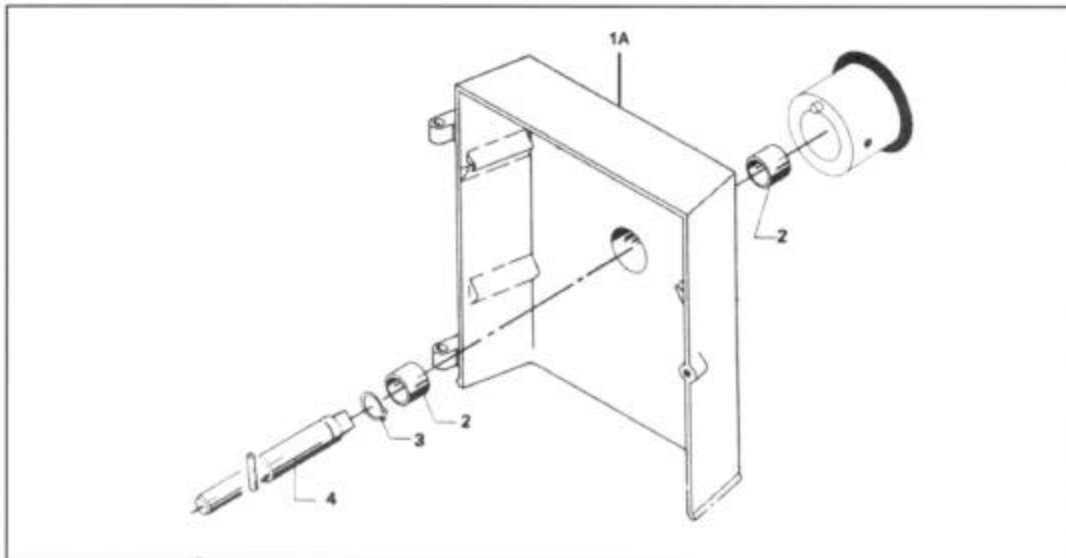
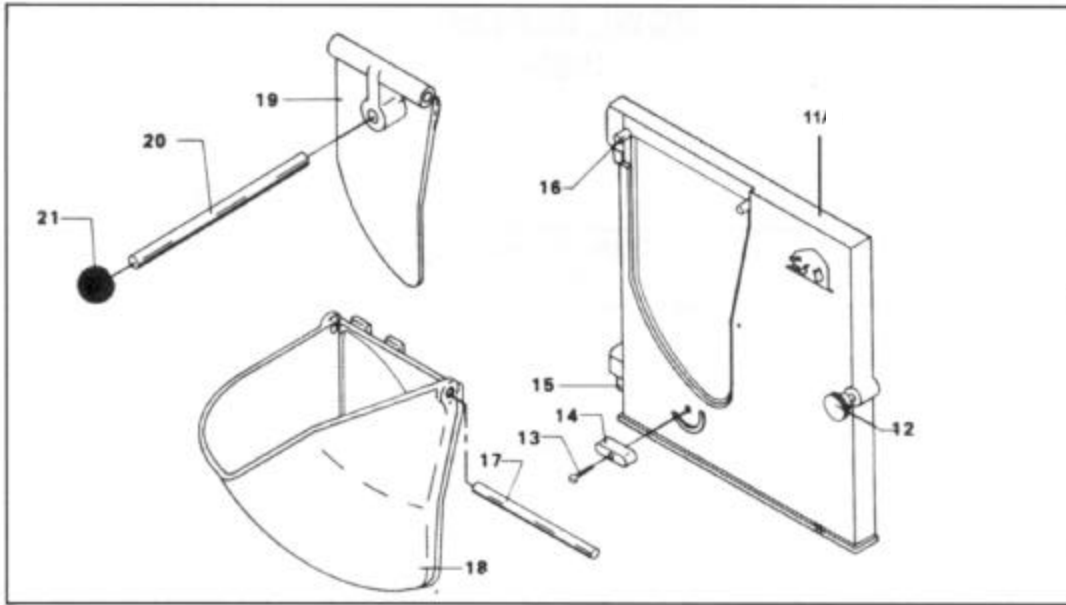

FIGURE 9

YOU ARE NOW READY TO CUT!

NOTE: Speed control has no effect on accessory attachment drive.

WARNING: Keep clear of moving parts and cutting accessories. Do not operate unit with front housing open.



1
1A

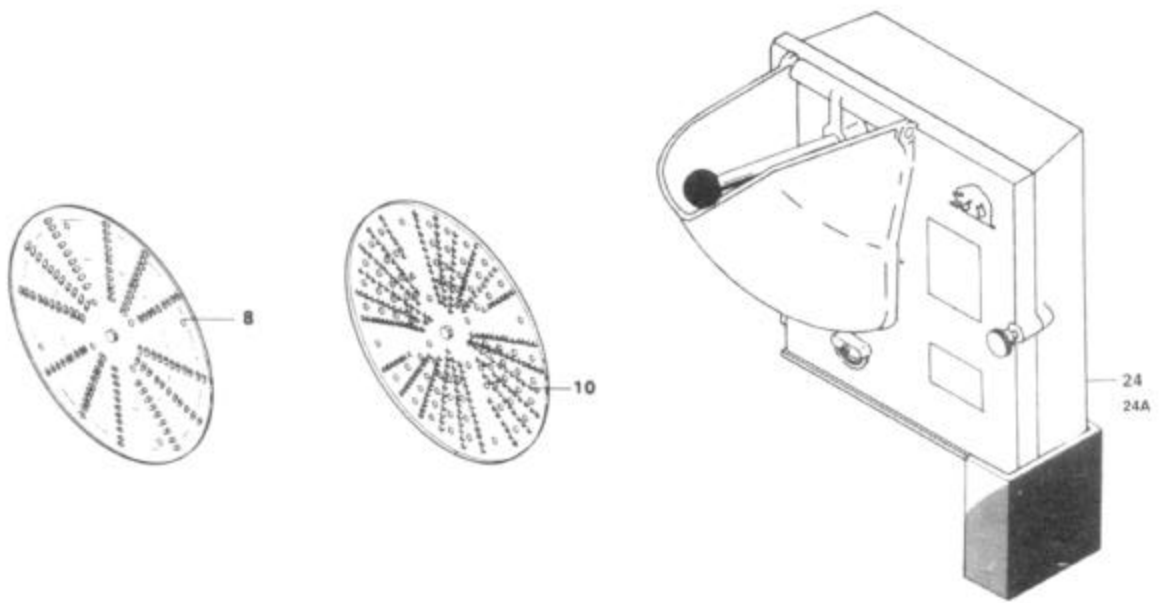

21

VEGETABLE SLICER / CHEESE GRATER

FIG NO.	DESCRIPTION	PART NUMBER
1.	Rear Housing #17	317A
1A.	Rear Housing #12	317N
2.	Bushing	STA 2537
3.	Snap Ring	STA 3410
4.	Shaft Assembly #17	17R100M
4A.	Shaft Assembly #12	17R100N
8.	Shredding Disc (1/16")	317G/2
8A.	Shredding Disc (1/8")	317G/3
8B.	Shredding Disc (3/16")	317G/5
8C.	Shredding Disc (1/4")	317G/7
10.	Grating Disc	317H
11.	Front Door Assembly (Items # 11 thru 16)	317B1
12.	Thumb Screw	17R102
13.	Screw	STA 5155
14.	Fastener	17R107
15.	Pin	STA 6425
16.	Pin	STA 6426
17.	Shaft for Pressure Lid	17R130
18.	Trough Assembly (Items # 17 thru 21)	317B2
18A.	Trough	17R004
19.	Pressure Lid	17R005
20.	Lever	20-146
21.	Knob	STA 3308
24.	Veg. Slicer Assembly #17	317
24A.	Veg. Slicer Assembly #12	317N

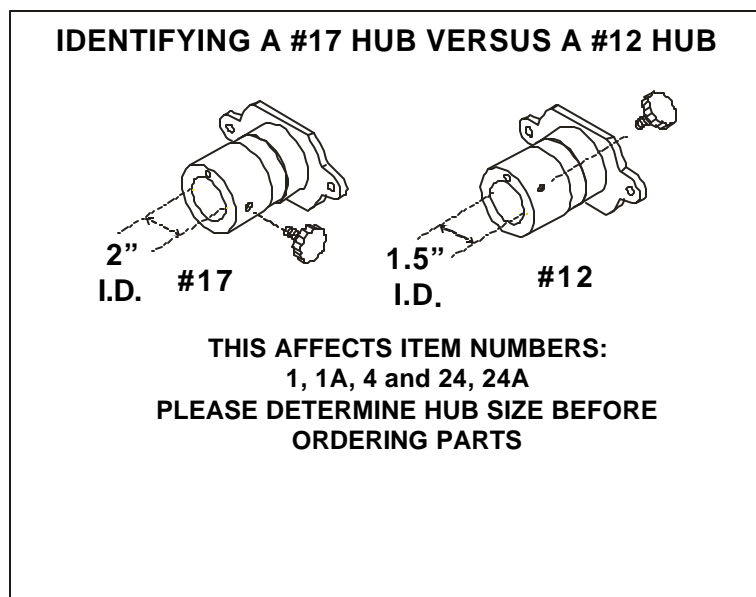

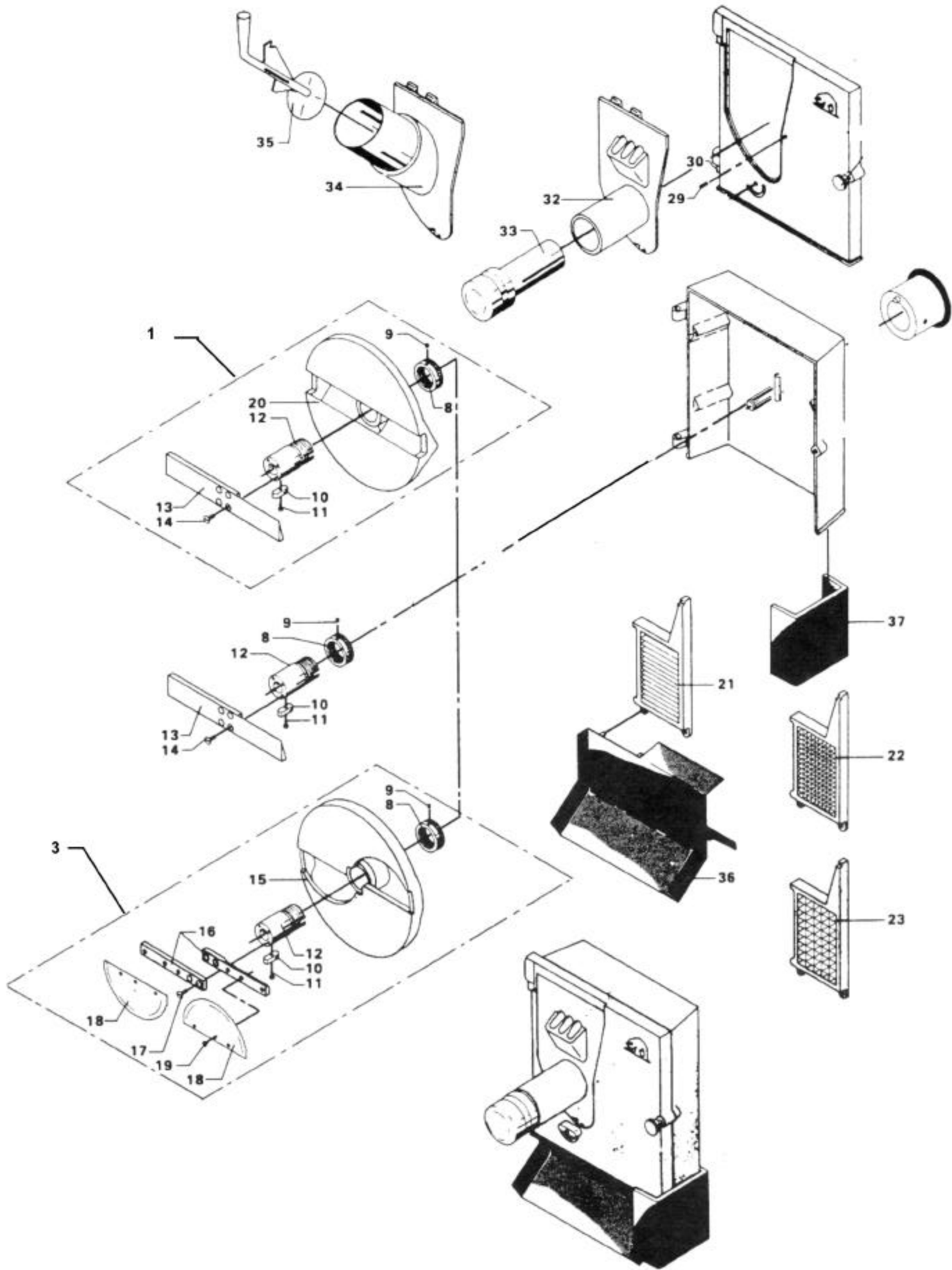

VEGETABLE SLICER / CHEESE GRATER ACCESSORIES

FIG NO.	DESCRIPTION	PART NUMBER
1.	Adjustable Knife	317E
3.	Soft Vegetable Knife	317D
8.	Nut	17R104
9.	Screw	STA 5715
10.	Key	17R108
11.	Screw	STA 5009
12.	Knife Hub	17R103
13.	Knife	17R300
14.	Screw	STA 5011
15.	Slicing Disc (Curved)	17R008
16.	Support for Curved Knife	17R106
17.	Screw	STA 5611
18.	Curved Knife	17R301
19.	Screw	STA 5007
20.	Slicing Discs (Straight Knife)	17R007
21.	Grate (French Fries)	317 I2/K
23.	Grate (Cube) 3/8 x 3/8	317I1/K
29.	Screw	STA 5710
30.	Pin	STA 6425
32.	Tubular Front	317L
33.	Stomper	6R351
34.	Diagonal Tube	317C
35.	Stomper	17R020
36.	Separating Skid	317K
37.	Splash Cover	17R318



Place the housing on the edge of a table, the opening upwards, when the meat mincer is to be assembled.



Ensure that the rubber ring is placed correctly in the housing. Do not use the meat mincer, if the rubber ring is missing.



The shaft of the feed screw should be lubricated with grease before the feed screw is inserted into the housing. Use e.g. paraffin oil or castor oil, never salad oil.

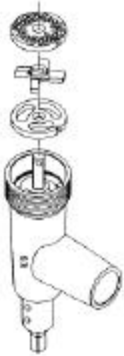

The knife set is to be mounted in the following order: Precutter, knife, and disc.

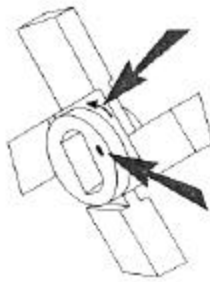

The knife is marked with an > 0 < or an **arrow** showing the direction of rotation. This marking faces forwards, when the knife is correctly mounted.



The thread of the housing should be lubricated with grease before the distance ring and the ring are mounted. Use e.g. paraffin oil or castor oil, never salad oil.



If a sausage tube is used, this should be mounted between the distance ring and the ring.

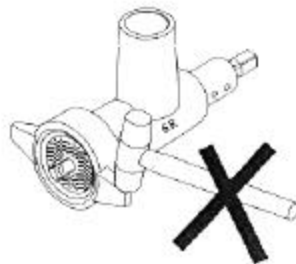

The ring should only be screwed slightly on by hand. **Never use a tool to tighten the ring, and never use a hammer.**

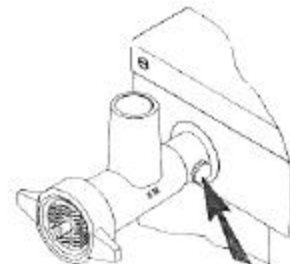

When the meat mincer has been assembled, it is mounted in the attachment engagement hub of the mixer. The meat mincer must be pressed into the attachment engagement hub before the thumb screw is tightened.

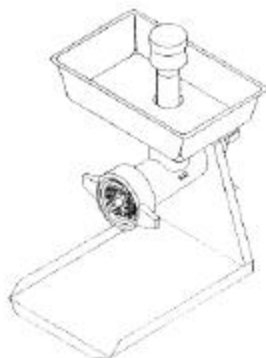

- For safety reasons **always** use the plunger when working with the meat mincer.
- The receiving tray (extra equipment) must be placed on the housing before the meat mincer is mounted on the mixer.
- When the meat mincer is in use, the mixer should run at lowest speed.

- Bones and frozen meat **must not** be put into the meat mincer.
- The meat mincer **must not** be used for making breadcrumbs or the like.
- Regarding cleaning and maintenance, see back page.

CLEANING:

After use the meat mincer is disassembled and cleaned. Washing should be done with a soft brush and pure water. Synthetic detergents should be used with care, as they destroy the lubricants of the bearings.

Do not use dishwasher for cleaning of the meat mincer, as the detergent can attack the aluminum parts of the meat mincer and destroy the lubricants of the bearings.

When the meat mincer is dry after washing, the shaft ends of the feed screw as well as the knife set should be rubbed with grease to avoid formation of rust. Use e.g. paraffin oil or castor oil, never salad oil.

If the meat mincer is washed in hot water, the parts should be cooled before the meat mincer is assembled.

The attachment engagement hub of the mixer should also be cleaned after use of the meat mincer. It is important that the hole for meat juice is cleaned.

If the feed screw is stuck, when the meat mincer is to be disassembled, it can be pulled out by inserting a hook or a similar tool in the hole of the feed screw shaft.

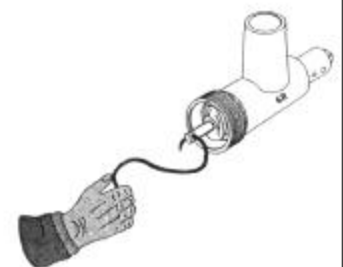

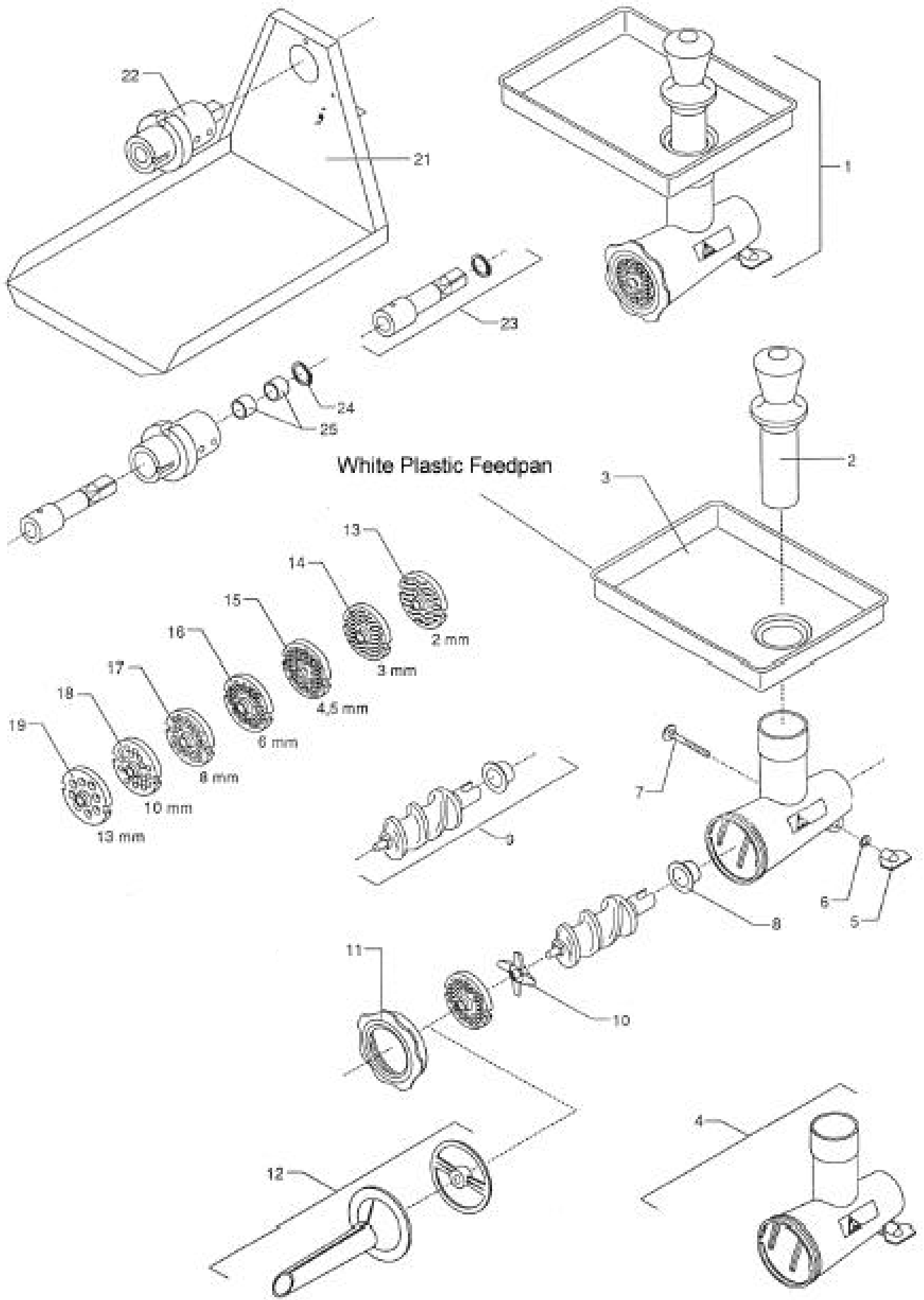

70 MM Meat Grinder

FIG NO.	DESCRIPTION	PART NUMBER
1.	70 MM Meat Grinder Complete #17	305
1A.	70 MM Meat Grinder Complete #12	305N
2.	Stomper	5R351
3.	Meat Tray	5R250
4.	Housing	5R1
5.	Wingnut	5R541
6.	Washer	STA 6020
7.	Bolt	5R542
8.	Bushing	5R540
9.	Feedscrew	5R3
10.	Knife	305/KNIFE
11.	Ring	5R2
12.	Sausage Tube	5R5
13.	1/16" Disc	305/2
14.	1/8" Disc	305/3
15.	3/16" Disc	305/5
16.	1/4" Disc	305/6
17.	5/16" Disc	305/8
18.	3/8" Disc	305/10
19.	1/2" Disc	305/13
21.	Receivng Tray	330
22.	Adaptor #17	4R1M
22A.	Adaptor #12	4R2M
23.	Shaft # 17	4R100M
23A.	Shaft #12	4R100N
24.	Snap Ring	STA 3410
25.	Bushing	STA 2520

IDENTIFYING A #17 HUB VERSUS A #12 HUB

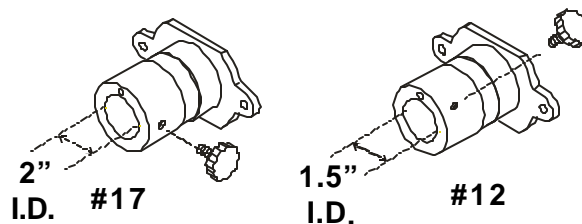

THIS AFFECTS ITEM NUMBERS:
1, 1A, 22 and 23
PLEASE DETERMINE HUB SIZE BEFORE
ORDERING PARTS

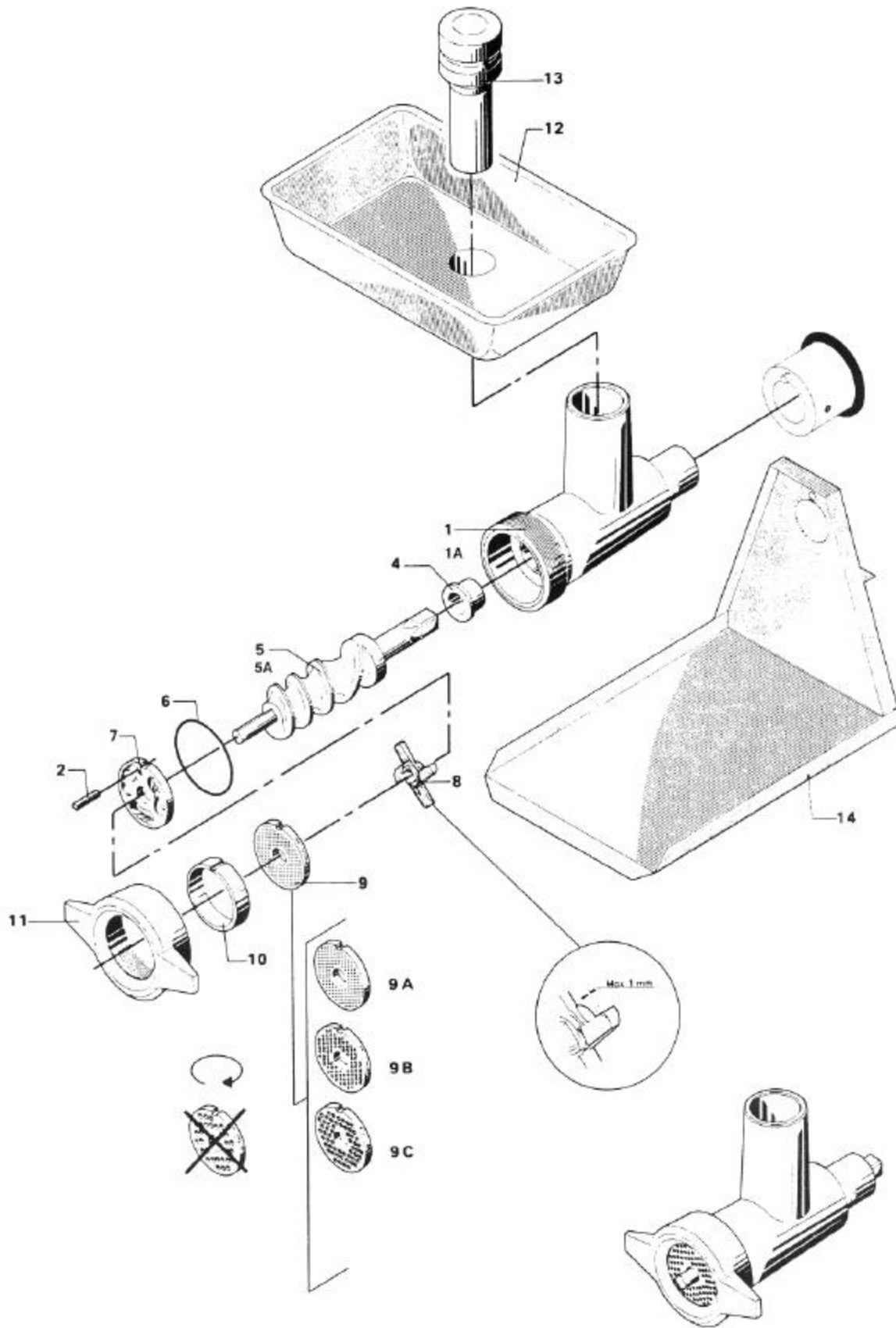

86 MM Meat Grinder

FIG NO.	DESCRIPTION	PART NUMBER
1.	Housing #17	6R001M
1A.	Housing #12	6R001
2.	Key	STA 2082
4.	Bushing	6R388
5.	Worm with Pin #17	6R003M
5A	Worm with Pin #12	6R003
6.	O-Ring	6R340
7.	Precutter	308
8.	Knife	306/KNIFE
9.	Disc 1/16"	306/2
9A.	Disc 1/8"	306/3
9B.	Disc 3/16"	306/5
9C.	Disc 1/4"	306/8
10.	Tightening Ring	6R345
11.	Cap	6R002
12.	Meat Tray	6R250
13.	Stomper	6R351
14.	Tray (Optional)	330

IDENTIFYING A #17 HUB VERSUS A #12 HUB

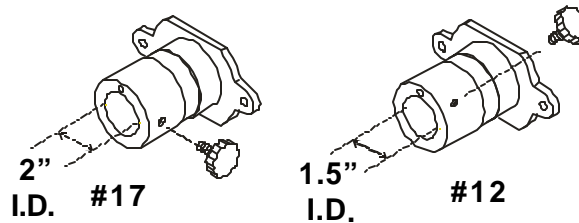

THIS AFFECTS ITEM NUMBERS:
 1, 1A, 5 and 5A
PLEASE DETERMINE HUB SIZE BEFORE
ORDERING PARTS

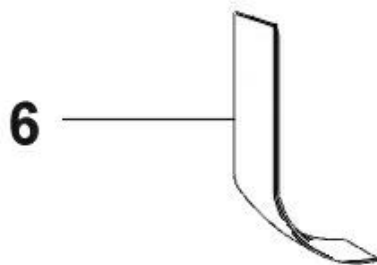
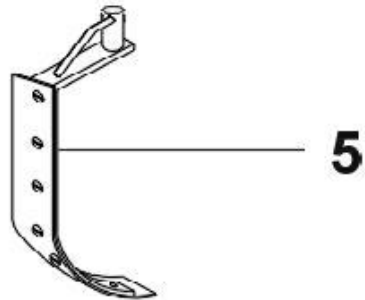
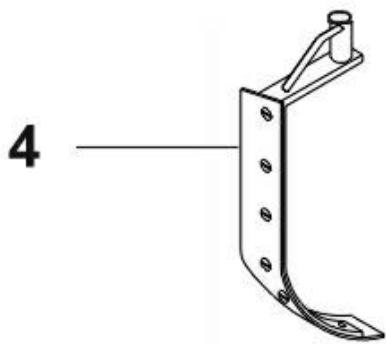
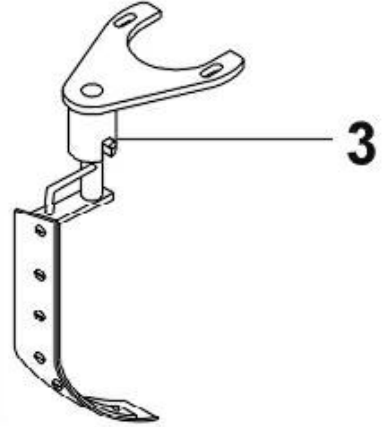
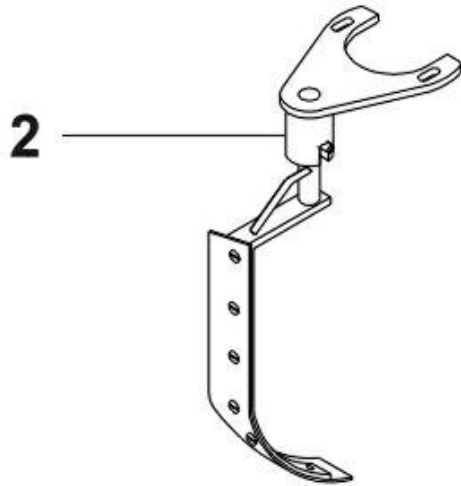
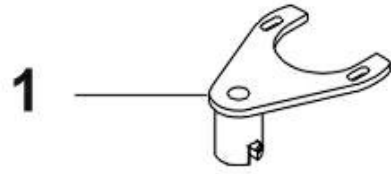

BOWL SCRAPER 1985-2000 (SCREW TYPE)

Fig. No.	Description	Order Number W30	Order Number W40 / W40P	Order Number W60 / W60P
1	SCRAPER HOLDER	42R30-101M	42R40-101M	42R60-101M
2	BOWL SCRAPER	224/30A	224/40A	224/60
3	BOWL SCRAPER (DOWNSIZE)	224/15	224/20B	224/30B
4	HOLDER WITH BLADE	42R30-102	42R40-102	42R60-102
5	HOLDER WITH BLADE (DOWNSIZE)	42R30A-102	42R40A-102	42R60A-102
6	NYLON BLADE W/SCREWS	42RN30-104	42R40-104	42R60-104
7	NYLON BLADE W/SCREWS (DOWNSIZE)	42RN30A-104	42R40A-104	42R60A-104

"KEYHOLE SCRAPER"

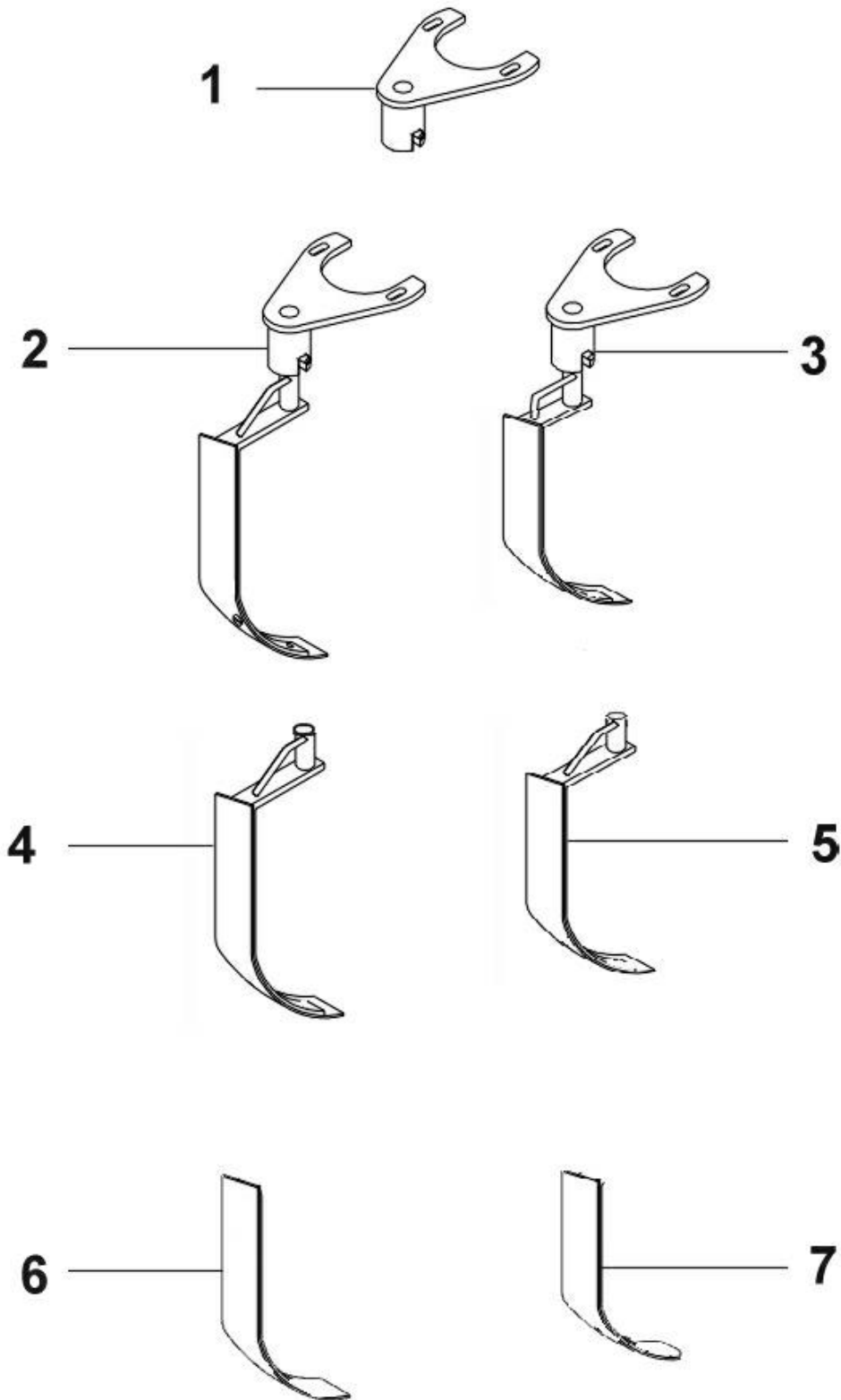

THE KEYHOLE SCRAPER DOES NOT USE SCREWS OF ANY KIND TO ATTACH THE NYLON BLADE TO THE SCRAPER ARM. IT IS SNAPPED INTO PLACE.

KEYHOLE BOWL SCRAPER 2000-

Fig. No.	Description	Order Number W30	Order Number W40 / W40P	Order Number W60 / W60P
1	SCRAPER HOLDER	42R30-101M	42R40-101M	42R60-101M
2	BOWL SCRAPER	224/30A	224/40A	224/60
3	BOWL SCRAPER (DOWNSIZE)	224/15	224/20B	224/30B
4	HOLDER WITH BLADE	42R30-202	42R40-202	42R60-202
5	HOLDER WITH BLADE (DOWNSIZE)	42R30A-202	42R40A-202	42R60A-202
6	NYLON BLADE	42RN30-204	42R40-204	42R60-204
7	NYLON BLADE (DOWNSIZE)	42RN30A-204	42R40A-204	42R60A-204

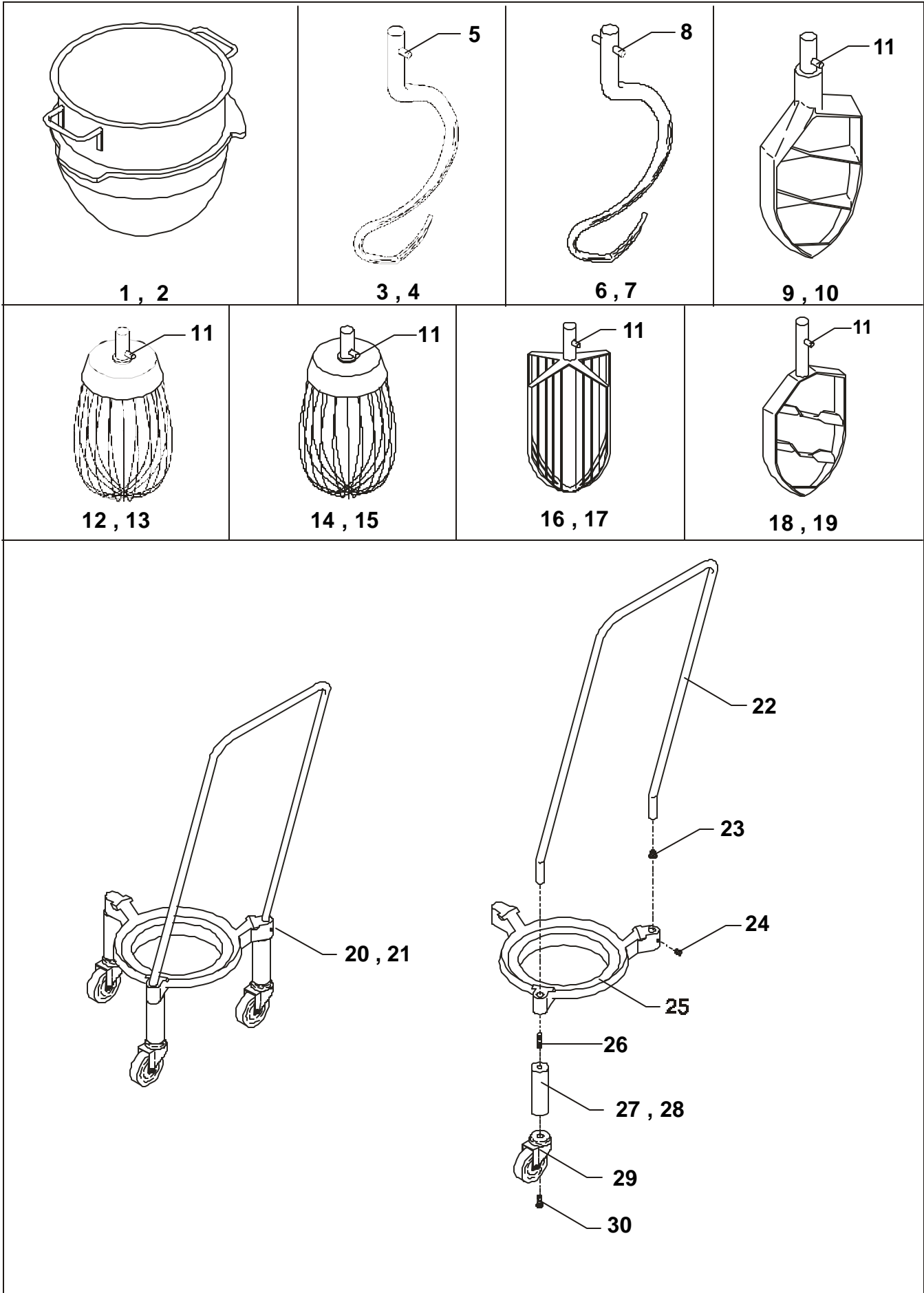

ATTACHMENTS AND OPTIONAL PRODUCTS

FIG. NO.	DESCRIPTION	PART NUMBER				
		W30 (A)	W40 (A)	W40P	W60 (A)	W60P
1.	Stainless Steel Bowl (Standard)	203/30A	203/40A	203/40A	203/60	203/60
2.	Stainless Steel Bowl (Downsize)	203/15	203/20A	203/20A	203/30B	203/30B
3.	Dough Hook (Single Pin)	213/30A	213/40A	213/40A	213/60	213/60
4.	Dough Hook (Single Pin,downsize)	213/15	213/20A	213/20A	213/30B	213/30B
5.	Tool Pin (Single)	30-79	40-79	40-79	60-79	60-79
6.	Dough Hook (Double Pin)	213/30D	213/40D	213/40D	213/60D	213/60D
7.	Dough Hook (Single Pin,downsize)	213/15	213/20B	213/20B	213/30B	213/30B
8.	Tool Pin (Double)	30-79D	40-79D	40-79D	60-79D	60-79D
9.	Flat Beater (Aluminum)	205/30A	205/40A	205/40A	205/60	205/60
10.	Flat Beater (Downsize, Aluminum)	205/15	205/20B	205/20B	205/30B	205/30B
11.	Tool Pin	STA 6261	STA 6261	STA 6261	STA 6263	STA 6263
12.	Wire Whip	207/30A	207/40A	207/40A	207/60	207/60
13.	Wire Whip (Downsize)	207/15	207/20B	207/20B	207/30B	207/30B
14.	Wire Whip (Heavy Duty)	221/30A	221/40A	221/40A	221/60	221/60
15.	Wire Whip (Downsize, Heavy Duty)	N/A	N/A	N/A	221/30B	221/30B
16.	Wing Whip	209/30A	209/40A	209/40A	209/60	209/60
17.	Wing Whip (Downsize)	N/A	N/A	N/A	209/30B	209/30B
18.	S/S Flat Beater	204/30A	204/40A	204/40A	204/60	204/60
19.	S/S Flat Beater (Downsize)	204/15	204/20B	204/20B	204/30B	204/30B
20.	Bowl Truck	215/30A	215/40A	215/40A	215/60	215/60
21.	Bowl Truck (Downsize Bowl)	215/15	215/20B	215/20B	215/30B	215/30B
22.	Bowl Truck Handle	22R270	22R270	22R270	22R270	22R270
23.	Plug Button	STA 6513	STA 6513	STA 6513	STA 6513	STA 6513
24.	Set Screw	STA 5602	STA 5602	STA 5602	STA 5602	STA 5602
25.	Bowl Truck Frame	22R30-40	22R30-40	22R30-40	22R30-40	22R30-40
26.	Screw	STA 5608	STA 5608	STA 5608	STA 5608	STA 5608
27.	Spacer (For Standard Bowl)	22R140.1-1W	22R140.1-4W	22R140.1-4W	22R140.1-5W	22R140.1-5W
28.	Spacer (For Downsize Bowl)	22R140.1-2W	22R140.1-1W	22R140.1-1W	22R140.1-1W	22R140.1-1W
29.	Castor	22R30-520	22R30-520	22R30-520	22R30-520	22R30-520
29A	Castor f/ Krispy Kreme	22R150-520	22R150-520	22R150-520	22R150-520	22R150-520
30.	Bolt	STA 5131	STA 5131	STA 5131	STA 5131	STA 5131

1985 - June 1998 1 Phase

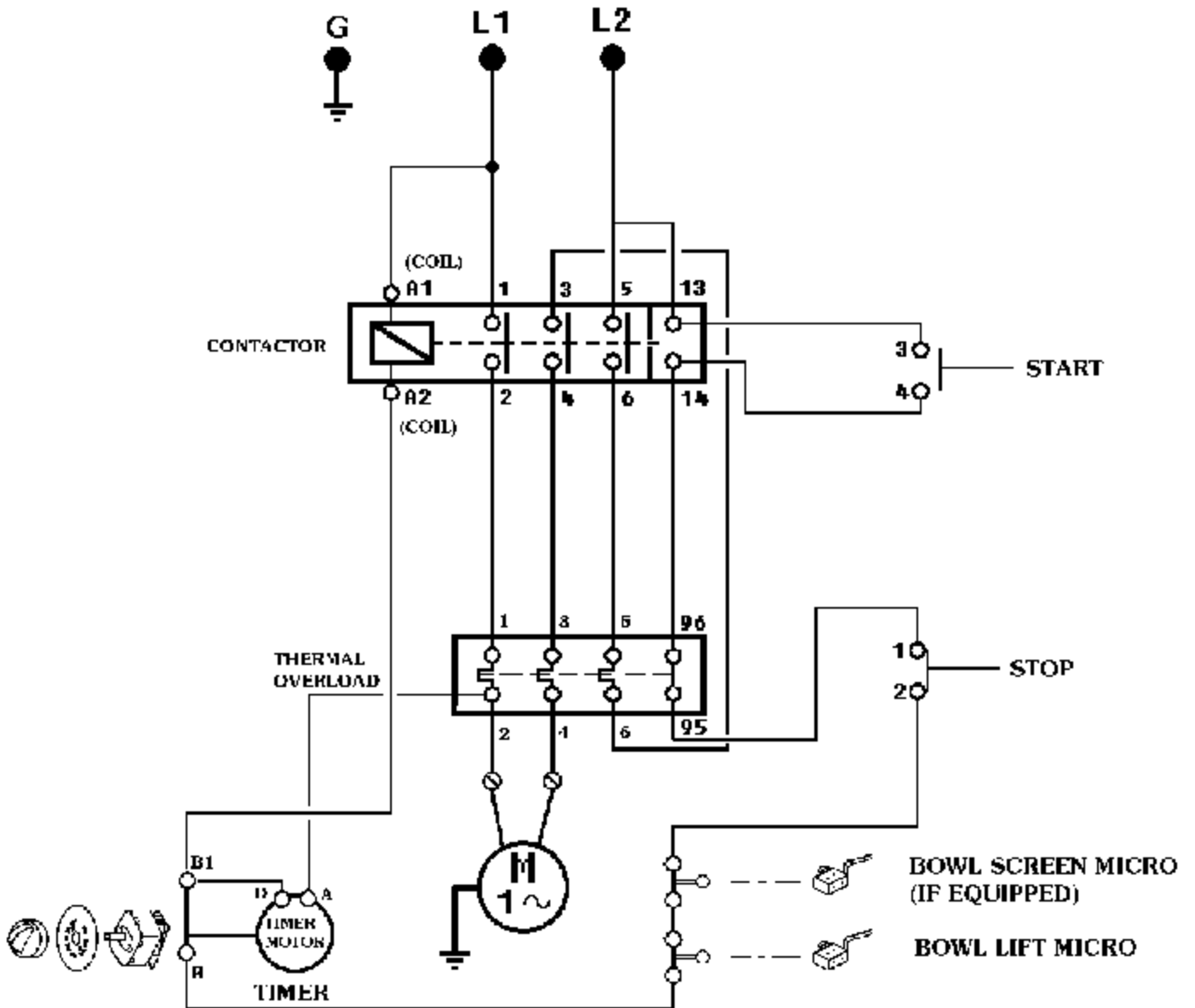

1985 - June 1998 3 Phase

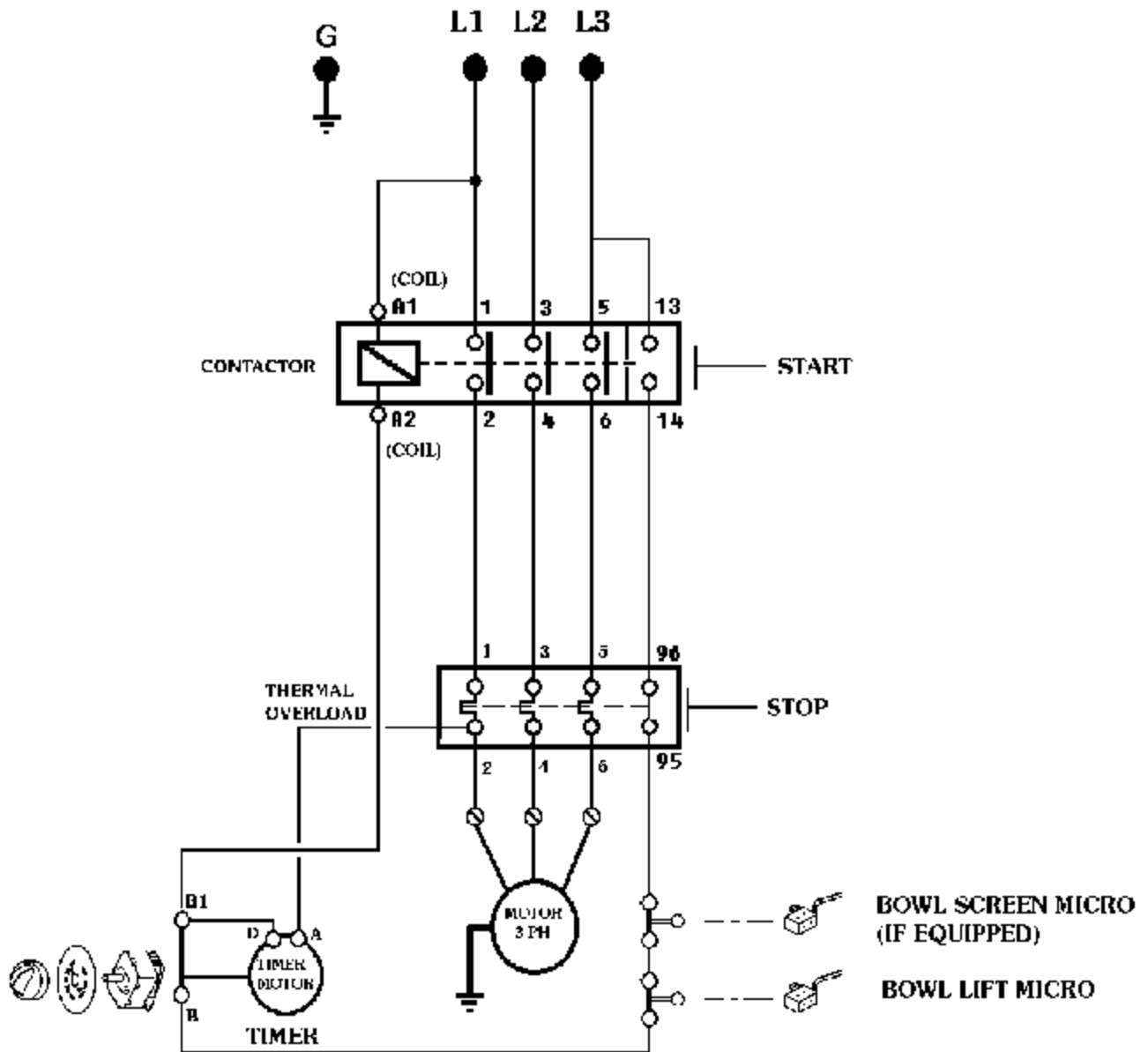

1998 - Present 1 Phase

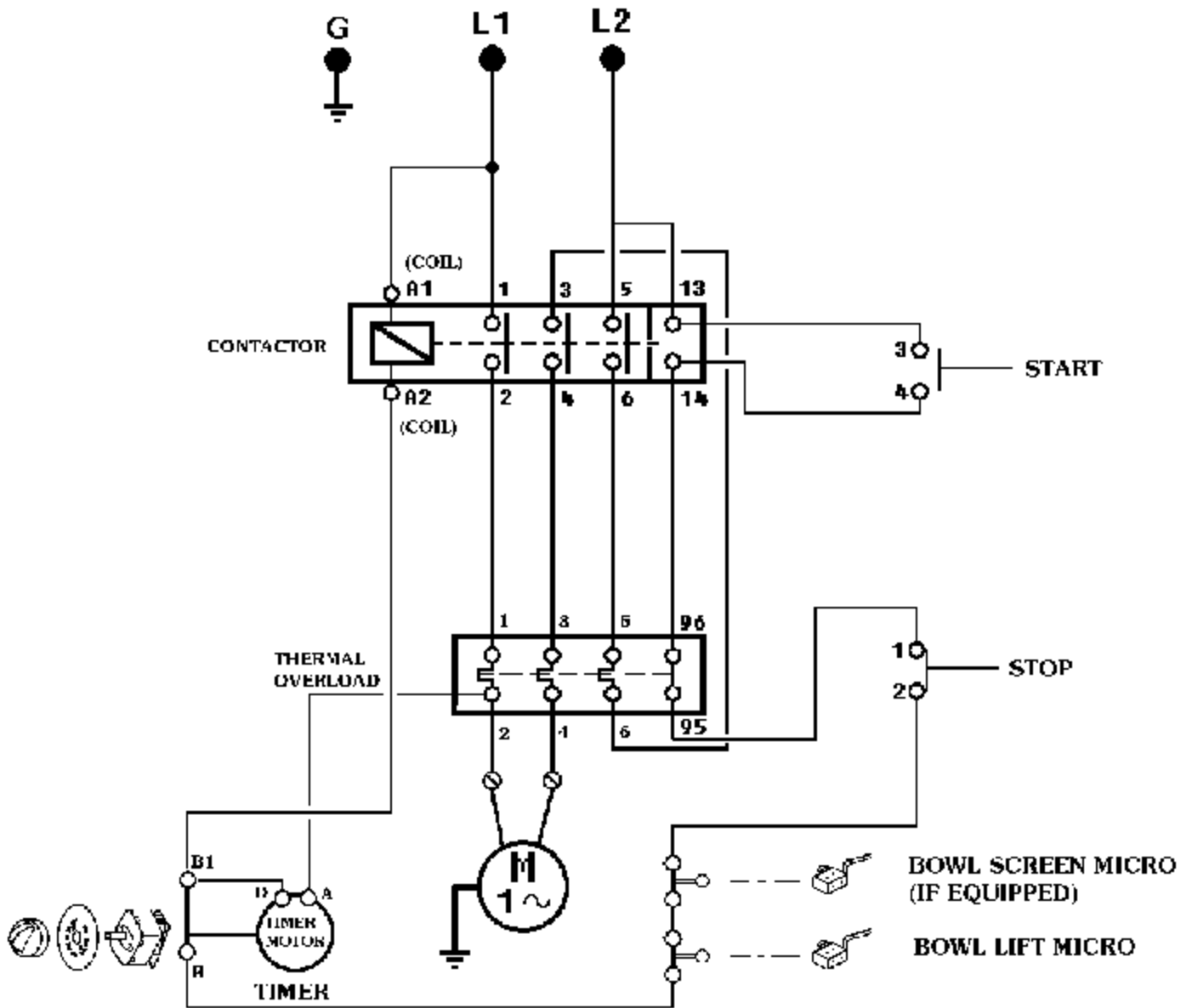

1998 - Present 3 Phase

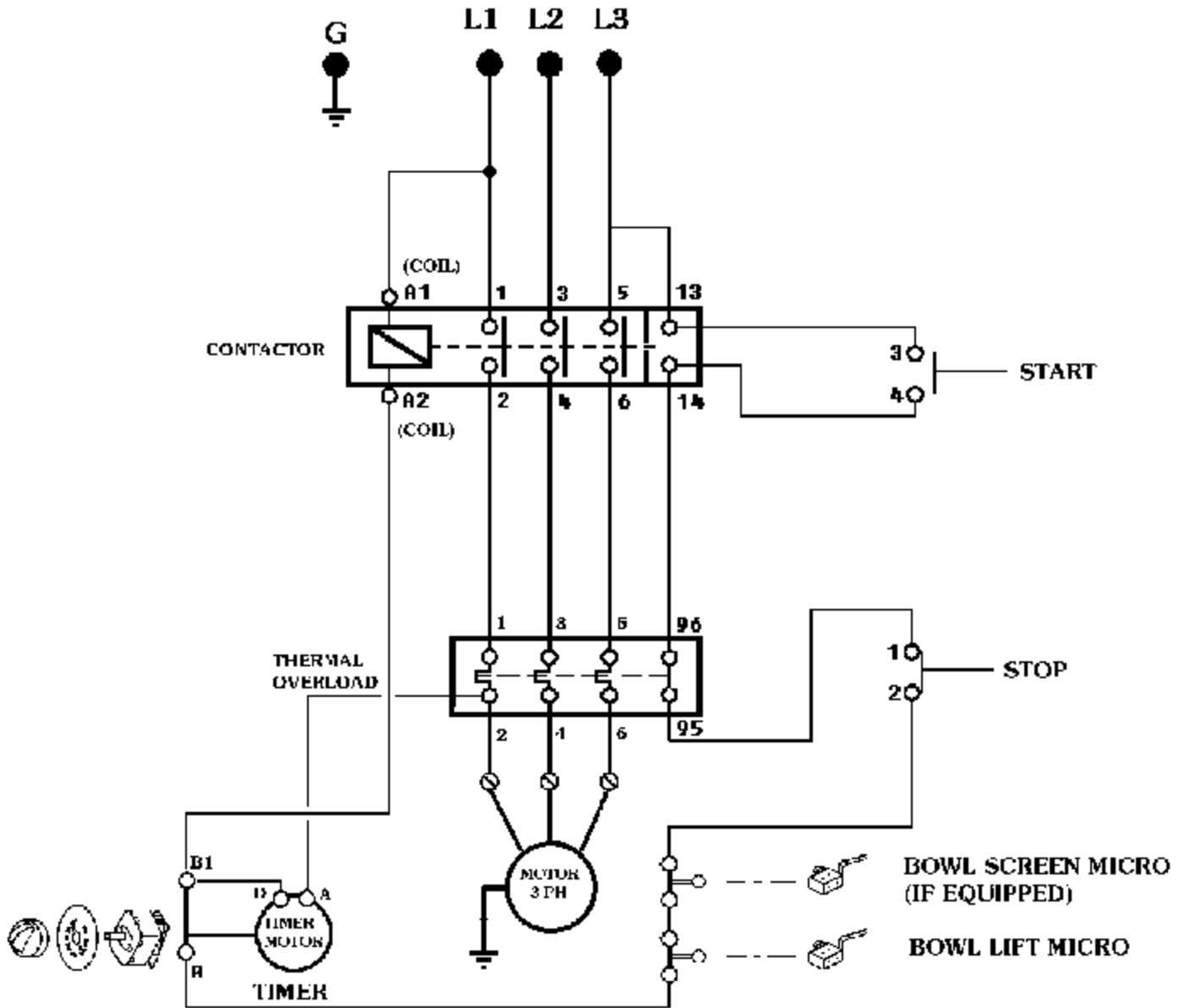



5489 Campus Dr.
Shreveport LA 71129
(800) 222-1138
(318) 635-3131 Fax
www.varimixer.com

Free Manuals Download Website

<http://myh66.com>

<http://usermanuals.us>

<http://www.somanuals.com>

<http://www.4manuals.cc>

<http://www.manual-lib.com>

<http://www.404manual.com>

<http://www.luxmanual.com>

<http://aubethermostatmanual.com>

Golf course search by state

<http://golfingnear.com>

Email search by domain

<http://emailbydomain.com>

Auto manuals search

<http://auto.somanuals.com>

TV manuals search

<http://tv.somanuals.com>