

**POWER ON BOARD 2 YEAR LIMITED WARRANTY PROGRAM**

This limited warranty program is the only one that applies to this product, and it sets forth all the responsibilities of Power on Board, regarding this product. There is no other warranty, other than those described herein.

This Power on Board product is warranted, to the original purchaser only, to be free of defects in materials and workmanship for two years from the date of purchase without additional charge. The warranty does not extend to subsequent purchasers or users. Power on Board will not be responsible for any amount of damage in excess of the retail purchase price of the product under any circumstances. Incidental and consequential damages are specifically excluded from coverage under this warranty.

This product is not intended for commercial use. This warranty does not apply to accessories or damage to units from misuse or incorrect connection/installation. Misuse includes wiring or connecting to improper polarity power sources.

**RETURN/REPAIR POLICY:** Defective products, other than accessories, may be returned to Power on Board. Any defective product, other than accessories, that is returned to Power on Board within 30 days of the date of purchase will be replaced free of charge. If such a product is returned more than 30 days but less than two years from the purchase date, Power on Board will repair the unit or, at its option, replace it free of charge.

If the unit is repaired, new or reconditioned, replacement parts may be used, at Power on Board's option. A unit may be replaced with a new or reconditioned unit of the same or comparable design. The repaired or replaced unit will then be warranted under the terms of the remainder of the warranty period. The customer is responsible for the shipping charges on all returned items after 30 days. During the warranty period, Power on Board will be responsible for the return shipping charges.

**LIMITATIONS:** This warranty does not cover accessories, bulbs, fuses and batteries, defects resulting from normal wear and tear (including chips, scratches, abrasions, discoloration or fading due to usage or exposure to sunlight), accidents, damage during shipping to our service facility, alterations, unauthorized use or repair, neglect, misuse, abuse, failure to follow instructions for care and maintenance, fire, flood or Acts of God.

If your problem is not covered by this warranty, call our Technical Support Department at (954) 584-4446 or toll free at (866) 584-5504 for general repair information and charges if applicable.

**STATE LAW RIGHTS:** This warranty gives you specific legal rights. Some states do not allow limitations on how long an implied warranty lasts or the exclusion or limitation of incidental or consequential damages, so the exclusions or limitations stated herein may not apply. This warranty gives the purchaser specific legal rights; other rights, which vary from state to state, may apply.

**TO REQUEST WARRANTY SERVICE FOR THIS PRODUCT:** Contact Power on Board Technical Support by telephone, fax or mail. We suggest that you keep the original packaging in case you need to ship the unit. When returning a product, include your name, address, phone number, dated sales receipt (or copy) and a description of the reason for return and product serial number. After repairing or replacing the unit, we will make every effort to return it to you within four weeks.

**WARRANTY ACTIVATION:** Please complete Warranty Activation Card and mail to Power on Board. Enter "VEC1028POB" as Model and "Power Center" as Product Type. All Power on Board products must be registered within 30 days of purchase to activate this warranty. Mail the completed registration form, along with a copy of the original sales receipt to:

ATTN.: CUSTOMER SERVICE  
4140 SW 30th Ave., Ft. Lauderdale, FL 33312  
• PH: 954-584-4446 • TOLL FREE: 866-584-5504 • FAX: 954-584-5556 •

WARRANTY IS NON-TRANSFERABLE AND NON-REFUNDABLE.

BD051605

© 2006 VECTOR MANUFACTURING  
MADE IN CHINA

**POWER<sup>®</sup>**  
**ON BOARD**

**Rechargeable**  
**Power Center**  
**AC/DC Portable Power Supply**  
**Jump-Starter/Air Compressor/Inflator**



**USER'S MANUAL**  
**& WARRANTY INFORMATION**

**IMPORTANT SAFETY INFORMATION, SAVE THESE INSTRUCTIONS**

TO REDUCE THE RISK OF INJURY, USER MUST READ AND UNDERSTAND THIS INSTRUCTIONAL MANUAL. THIS MANUAL CONTAINS IMPORTANT INFORMATION REGARDING THE OPERATION AND WARRANTY OF THIS PRODUCT. PLEASE RETAIN FOR FUTURE REFERENCE.

4140 S.W. 30th Ave., Ft. Lauderdale, FL 33312  
Toll Free: (866) 584-5504

# **IMPORTANT SAFETY INSTRUCTIONS**

## **WARNINGS**

- 1. RISK OF EXPLOSIVE GAS MIXTURES – WORKING IN THE VICINITY OF A LEAD-ACID BATTERY IS DANGEROUS. BATTERIES GENERATE EXPLOSIVE GASES DURING NORMAL BATTERY OPERATION. FOR THIS REASON, IT IS OF UTMOST IMPORTANCE THAT EACH TIME BEFORE USING THIS UNIT, YOU READ THIS MANUAL AND FOLLOW THE INSTRUCTIONS EXACTLY.**
- 2. To reduce risk of battery explosion, follow these instructions and those published by the battery manufacturer and manufacturer of any equipment you intend to use in vicinity of battery. Review cautionary markings on these products and on engine.**
- 3. This equipment employs parts (switches, relays, etc.) that produce arcs or sparks. Therefore, if used in a garage or enclosed area, the unit MUST be placed not less than 18 inches above the floor.**

## **Battery Safety**

1. When working with lead acid batteries, always make sure immediate assistance is available in case of accident or emergency.
2. Always use protective eyewear when using this product: contact with battery acid may cause blindness and/or severe burns. Be aware of first aid procedures in case of accidental contact with battery acid.
3. There is a risk of releasing explosive gases when lead acid batteries are charged or discharged. Failure to follow instructions may cause property damage and/or personal injury.
4. When connecting the battery clamps to a discharged battery and an alarm sounds – the clamp connections are incorrect and need to be reversed.
5. Jump-start procedures should only be performed in a safe, dry, well-ventilated area.
6. Always store battery clamps on the clamp tabs on the back of the unit when not in use. Never touch battery clamps together. This can cause dangerous sparks, power arcing and/or explosion.
7. When using this unit close to the vehicle's battery and engine, stand the unit on a flat, stable surface, and be sure to keep all clamps, cords, clothing and body parts away from moving vehicle parts.
8. Do not wear vinyl clothing when jump-starting a vehicle, friction can cause dangerous static-electrical sparks. Remove all jewelry or metal objects that could cause short circuits or react with battery acid.
9. Never allow RED and BLACK clamps to touch each other or another common metal conductor – this could cause damage to the unit and/or create a sparking/explosion hazard.
10. a. For negative-grounded systems (most common), connect the POSITIVE (RED) clamp to the POSITIVE ungrounded battery post and the NEGATIVE (BLACK) clamp to the vehicle chassis or engine block away from the battery. Do not connect the clamp to the carburetor, fuel lines or sheet-metal body parts. Connect to a heavy gauge metal part of the frame or engine block.  
b. For positive-grounded systems, connect the NEGATIVE (BLACK) clamp to the NEGATIVE ungrounded battery post and the POSITIVE (RED) clamp to the vehicle chassis or engine block away from the battery. Do not connect the clamp to the carburetor, fuel lines or sheet-metal body parts. Connect to a heavy gauge metal part of the frame or engine block.
11. Always disconnect the NEGATIVE (BLACK) jumper cable first, followed by the POSITIVE (RED) jumper cable, except for positive grounded systems.
12. Do not expose battery to fire or intense heat since it may explode. Before disposing of the battery, protect exposed terminals with heavy-duty electrical tape to prevent shorting (shorting can result in injury or fire).
13. Do not smoke or use flammable items (matches, cigarette lighters, etc.) while working on a vehicle's battery system.
14. DO NOT ATTEMPT TO JUMP-START A FROZEN BATTERY.
15. Place this unit as far away from the battery as DC cables permit.
16. Never allow battery acid to come in contact with this unit.
17. Vehicles that have on-board computerized systems may be damaged if vehicle battery is jump-started. Before jump-starting, read the vehicle's owners manual to confirm that external-starting assistance is suitable.

## **Compressor/Inflator Safety**

1. Never attempt to disable or block the inflation and deflation ports while pump is operating.
2. Never cover unit at any time.
3. Never leave the pump unattended while in use.
4. Never allow sand, small rocks or other debris to be sucked into the inflation or deflation ports.
5. Never look into or point the inflator port opening toward anyone's eyes.
6. Do not use the compressor continuously for longer than 15 minutes. Extended use will cause it to overheat and can damage the product. After 15 minutes of continuous use, turn the unit OFF and wait 15 minutes before resuming operation of the compressor.
7. DO NOT overinflate objects or exceed manufacturer's recommendations for pressure on objects to be inflated.

## **Personal Safety**

### **FIRST AID**

**SKIN:** If battery acid comes in contact with skin, rinse immediately with water, then wash thoroughly with soap and water. If redness, pain or irritation occurs, seek immediate medical attention.

**EYES:** If battery acid comes in contact with eyes, flush eyes immediately for a minimum of 15 minutes and seek immediate medical attention.

### **CAUTIONS**

1. When using an extension cord (not supplied) for AC charging/recharging, make sure it has the same configuration as the plug of the unit and that the cord is properly wired and in good condition. The cord must be suitable for 120 volts AC and have a minimum 2 amp rating.
2. Do not recharge for more than 5-6 hours maximum using the 12 volt DC method. Recharge unit after each use.
3. All ON/OFF switches should be in the OFF position when the unit is charging or not in use. Make sure all switches are in the OFF position before connection to a power source or load.
4. Never insert anything other than the supplied power/recharging cords or recommended appliance power/recharging cords into the 12 volt DC charging/power outlet on this unit. Do not use any accessory that is not recommended or provided by the manufacturer.
5. Do not use this unit to operate appliances that need more than 5 amps to operate from the 12 volt DC accessory outlet.
6. This system is designed to be used only on vehicles with a 12 volt DC battery system. Do not connect to a 6 volt or 24 volt battery system.
7. This system is not designed to be used as a replacement for a vehicle battery. Do not attempt to operate a vehicle that does not have a battery installed.
8. Excessive engine cranking can damage a vehicle's starter motor. If the engine fails to start after the recommended number of attempts, discontinue jump-start procedures and look for other problems that may need to be corrected.
9. Although this unit contains a non-spillable battery, it is recommended that unit be kept upright during storage, use and recharging. To avoid possible damage that may shorten the unit's working life, protect it from direct sunlight, direct heat and/or moisture.
10. Check unit periodically for wear and tear. Contact the Customer Service Department at (866) 584-5504 to replace worn or defective parts.
11. Do not drop this unit as it may damage the product. If unit is dropped or damaged, please discontinue using it.
12. NEVER submerge this unit in water.
13. Store indoors. Do not operate unit in rain or snow, or use when wet.
14. Do not operate this unit in a closed area or restrict ventilation in any way.

THIS UNIT IS NOT FOR USE BY CHILDREN AND SHOULD ONLY BE OPERATED BY ADULTS.

**SAVE THESE INSTRUCTIONS**

# TABLE OF CONTENTS

Introduction	1
Features	1
AC and DC Charging/Recharging	3
Viewing Battery Charge Status	3
120 Volt AC Charging	4
12 Volt DC Charging	4
Using the Power Center as a Jump- Starter	4
Using the 12 Volt Portable Power Supply	6
Using the 120 Volt AC Power Supply	6
Using the Emergency Area Light	7
Using the Air Compressor/Inflator	7
Inflating Products With a Valve Stem Using the Compressor	7
Inflating Products Without a Valve Stem Using the Compressor	8
Using the Inflator/Deflator	8
Care and Maintenance	9
Replacement Parts	9
Battery Replacement/Disposal	9
Fuse Replacement (DC Accessory Adapter)	9
Specifications	10

## INTRODUCTION

Thank you for purchasing the **VEC1028POB Power Center**. Please read this guide carefully before use to ensure optimum performance and avoid damage to the unit.

## FEATURES

- Powers 110/120 volt AC appliances
- Powers 12 volt DC appliances
- Jump-starts vehicle engines
- Built-in air compressor/inflator with pressure gauge, hoses and adapters
- Built-in 400 watt inverter
- Includes non-spillable, maintenance-free, heavy-duty, sealed battery
- Safe to use, transport and store
- Reverse polarity connection warning
- Self-stored jumper cables
- Requires no maintenance (other than recharging) for optimum operation
- Rechargeable with built-in AC charger
- Unique compact design provides completely portable 12 volt DC power
- Molded high-impact case is tough and durable
- Built-in area light for night time roadside repairs and use in remote locations without utility power
- Battery charge level indicators

This device complies with part 15 of the FCC rules. Operation is subject to the following two conditions: (1) this device may not cause harmful interference, and (2) this device must accept any interference received, including interference that may cause undesired operation.

This equipment has been tested and found to comply with the limits for a Class B digital device, pursuant to part 15 of the FCC Rules. These limits are designed to provide reasonable protection against harmful interference in a residential installation. This equipment generates, uses and can radiate radio frequency energy and, if not installed and used in accordance with the instructions, may cause harmful interference to radio communications. However, there is no guarantee that interference will not occur in a particular installation. If equipment does cause harmful interference to radio or television reception, which can be determined by turning the equipment off and on, the user is encouraged to try to correct the interference by one or more of the following measures:

- Reorient or relocate the receiving antenna.
- Increase the separation between equipment and receiver.
- Connect the equipment into an outlet on a circuit different from that to which the receiver is connected.
- Consult the dealer or an experienced radio/TV technician for help.

## Protective Features

- **Automatic Overload** — Built-in protection against overload — in the event the AC outlet draws more than 400 watts, power to the unit's outlet will automatically shut off.
- **Ground Fault Circuit Interrupter (GFCI)** — The GFCI protects the unit and the user by sensing imbalances in a circuit caused by current leakage to the ground and shuts down the unit's AC outlet to prevent electrical shock.
- **Overheating** — Unit automatically shuts down if it exceeds a safe temperature.
- **Safety Power Switch and Reverse Polarity Alarm** — In the event the cables/clamp connections are reversed during jump-starting, an indicator lights and an alarm sounds BEFORE the Power Switch is turned ON.
- **Low Battery** — If the battery power level is too low, the AC Power Supply shuts down automatically.

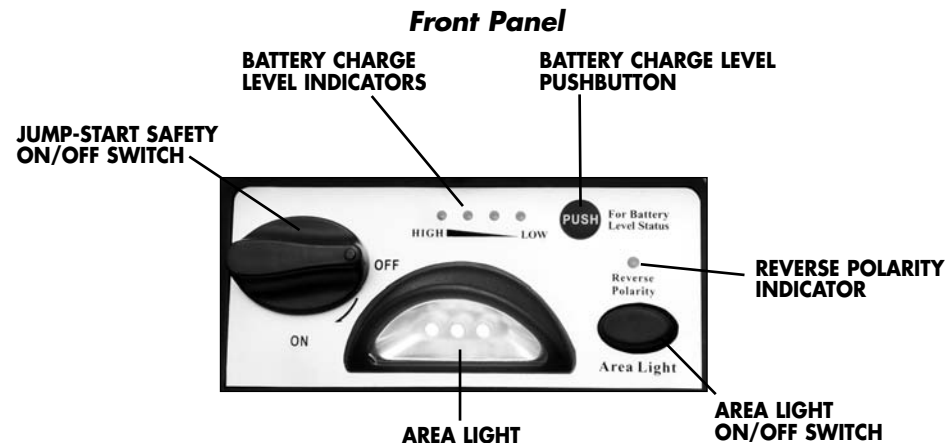
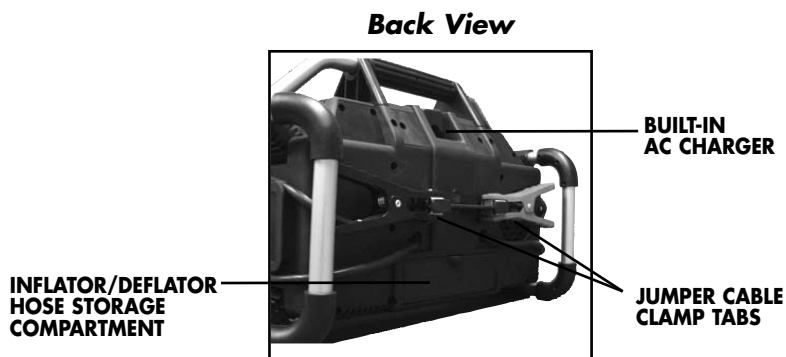
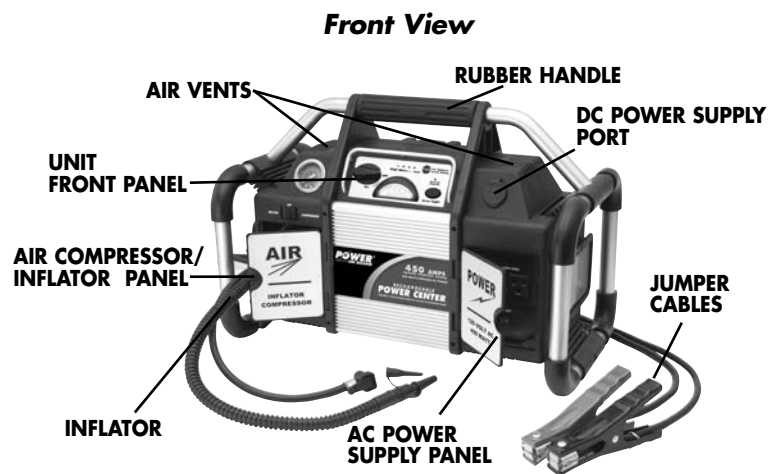

## AC AND DC CHARGING/RECHARGING

Use a common household AC extension cord for charging (cord not supplied).

For maximum battery life, we recommend the unit be kept fully charged at all times. If the battery is allowed to remain in a discharged state, battery life will be shortened.

- MAKE SURE ALL SWITCHES ARE TURNED OFF DURING RECHARGING.
- FULLY CHARGE THE UNIT USING THE 120 VOLT AC CHARGING METHOD BEFORE FIRST USE.
- Recharge the unit fully after each use.
- Recharge the unit every two months when it has not been used regularly.

**Notes:** *Recharging the battery after each use prolongs battery life; frequent discharges between recharges reduces battery life.*

*The Power Center also comes with a 12 Volt DC charging adapter for recharging the unit from a 12 volt DC accessory outlet in a vehicle.*

*If unit is fully discharged, it is recommended that the vehicle being used for recharging be left running while the unit is charged via the 12 volt DC method.*

## Viewing Battery Charge Status

Press the Battery Charge Level pushbutton to display battery status. The Battery Charge Level Indicator LEDs will light.

### LEDs (from right to left):

- One Red LED indicates a low battery charge
- Two or three Red LEDs indicate a medium level or partially charged battery
- Three Red and one Green LEDs indicates a full or high level battery charge.

## 120 Volt AC Charging

1. Lift the AC Charger cover located on the back of the **Power Center** and connect a standard household extension cord to the unit. Plug the other end of the cord into a standard North American 120 volt AC wall outlet.



2. Charge until three Red and one Green LEDs light.
3. Once fully charged, disconnect the extension cord.

**Note:** The unit cannot be overcharged using this method.

## 12 Volt DC Charging

The 12 Volt DC recharging method will NOT recharge the unit as effectively as recharging from 120 volt AC. The 12 volt DC recharging procedure is recommended only when it is necessary, since frequent use of the 12 volt DC recharging procedure may shorten the battery system's life.

1. Insert the gold-tipped DC Charging Adapter end plug into the vehicle's 12 volt DC accessory outlet.
2. Insert the silver-tipped end plug into the 12 volt DC accessory outlet on the front panel of the unit.
3. To check the charge status of the battery during DC charging, disconnect the DC adapter from the accessory outlet and push the Battery Charge Level pushbutton. Observe the battery charge indicator.
4. When charging is complete, remove the power cord.



### ⚠ WARNING

**Do not recharge for more than 5 to 6 hours maximum using the 12 volt DC method.**

## USING THE POWER CENTER AS A JUMP-STARTER

### ⚠ WARNINGS

- Before using this system to jump-start any vehicle read and understand all instructions, safety tips, warnings, cautions and first aid information provided in this manual and on the product labeling. Additional important information may also be provided by the vehicle's battery system manufacturer.
- Connect or disconnect battery leads **ONLY** when AC or DC charging supply cords are disconnected.

### ⚠ CAUTIONS

- To avoid possible damage that may shorten the unit's working life, protect this unit from direct sunlight, direct heat and moisture.
- This system is to be used **ONLY** on vehicles, garden tractors and gasoline-powered generators with 12 volt DC battery systems.
- This system is **NOT** designed to be installed as a replacement for a vehicle battery.

## Jump-Starting Instructions

This jump-starter is equipped with a manual safety switch that only allows jump-start energy to flow when proper connections are made to battery and frame.

Connect — RED clamp first, then BLACK clamp. Disconnect — BLACK clamp first, then RED clamp.

1. Turn OFF vehicle ignition and all accessories (radio, A/C, lights, cell phone, etc.). Place vehicle in "park" and set the emergency brake.
2. Make sure jump-start system's ON/OFF power switch is turned to OFF.
3. Connect jumper cables to unit.
4. To jump-start a **NEGATIVE GROUNDED SYSTEM** (NEGATIVE battery terminal is connected to the chassis — the most common configuration), follow steps 4a and 4b, then proceed to step 6.
  - 4a. Connect the **POSITIVE (+) RED** clamp to vehicle battery's **POSITIVE** ungrounded post.
  - 4b. Connect the **NEGATIVE (-) BLACK** clamp to the vehicle chassis or engine block away from the battery. Do not connect the clip to carburetor, fuel lines or sheet-metal body parts. Connect to a heavy gauge metal part of the frame or engine block.
5. To jump-start a **POSITIVE GROUNDED SYSTEM** — In the rare event that the vehicle to be started has a **POSITIVE** Grounded System, **POSITIVE** battery terminal is connected to chassis, replace steps 4a and 4b above with steps 5a and 5b, then proceed to step 6.
  - 5a. Connect **NEGATIVE (-) BLACK** clamp to vehicle battery's **NEGATIVE** ungrounded post.
  - 5b. Connect **POSITIVE (+) RED** clamp to the vehicle chassis or engine block away from the battery. Do not connect the clip to carburetor, fuel lines or sheet-metal body parts. Connect to a heavy gauge metal part of the frame or engine block.

**DO NOT TURN SAFETY SWITCH ON IF REVERSE POLARITY ALARM SOUNDS OR THE REVERSE POLARITY INDICATOR LIGHTS. REVERSE THE CLAMP CONNECTIONS.**

6. After making proper connections, turn safety power switch to ON.
7. Start vehicle (do not turn key for longer than 5-6 seconds).
8. After vehicle starts, turn the safety power switch to off, remove clamps (disconnect the frame or engine clamp first, followed by the battery cable). Store the cables on the clamp tabs on the back of the unit.

**Notes:** Always disconnect the engine or frame jumper clamp first; followed by the battery jumper clamp.

*If engine fails to start, leave the ignition turned off and disconnect the **NEGATIVE (-) clamp** first, then the **POSITIVE (+) clamp**. Try again later — the engine may be flooded.*

**Recharge the Power Center after each use.**

## USING THE 12 VOLT DC PORTABLE POWER SUPPLY

1. Flip open the 12 Volt DC Outlet cover on the upper right side of the unit.
2. Insert the 12 volt DC plug from the appliance into the outlet.
3. Turn on the appliance and operate normally.



### ⚠ CAUTION

**DO NOT USE UNIT TO POWER APPLIANCES THAT DRAW MORE THAN 5 AMPS DC.**

## USING THE 120 VOLT AC POWER SUPPLY

The **Power Center** comes with:

1. AC ON/OFF Switch — Press switch to turn the AC Power Supply ON and OFF.
2. Dual 120 Volt AC Power Outlets
3. AC Power Supply "ON" Status Indicator — green LED lights when AC outlet is turned on; green LED flashes on and off when faulted.
4. AC Power Ground Fault Circuit Interrupt (GFCI) — two three-prong outlets for 110/120 volt AC appliances which shut down inverter if leakage or ground fault current is detected.
5. Internal protective circuits including:
  - Overload and over-temperature shutdown (activated if AC output exceeds 400 watts or the unit overheats)
  - AC short-circuit shutdown
  - Low voltage shutdown
  - A new cooling technology that more efficiently cools the power transistors, dramatically increasing reliability and product life.



### AC Power Supply Controls and Indicators

The illustration above details the AC Power Supply Panel. The ON/OFF switch turns the AC power circuitry on and off. The ON/OFF switch can also be used to reset the AC power after shutdown due to overvoltage, overload or over-temperature condition. The "ON" status indicator lights when the AC power supply is on.

### AC Power Supply Operation

1. Turn power switch to ON (the power indicator lights).
2. Plug in appliance and operate as usual.

**Note: The AC power supply shuts down automatically when the battery voltage level is too low. If the green LED flashes, a faulty condition such as an overload, overheating or short circuiting has occurred. Turn the AC Power Supply OFF and unplug the appliance. Wait a few minutes, then turn power back ON.**

## USING THE EMERGENCY AREA LIGHT

The Area Light is controlled by an ON/OFF pushbutton. Make sure the light is turned OFF when the unit is being recharged or stored.

## USING THE AIR COMPRESSOR/INFLATOR

The built-in 12 volt DC Air Compressor is the ultimate inflator for all vehicle tires, trailer tires and sports inflatables. The attached Air Compressor Hose with standard tire valve connector (chuck) and three different sized nozzles are located on the front left panel of the unit in the compartment labeled "Air."

Each nozzle clips on the end of the standard tire valve connector attached to the free end of the air compressor hose.

The Inflator/Deflator is useful for quickly inflating and deflating such items as air mattresses, pool toys, etc. The detached Inflator/Deflator Hose connects to either the Inflator or Deflator port also located in the compartment labeled "Air" on the front left panel of the unit. The Inflator/Deflator Hose is stored in a compartment in the back of the unit.

### ⚠ WARNING

**The air compressor is capable of inflating up to 120 pounds per square inch (psi). To avoid overinflating, carefully follow instructions on articles to be inflated. Never exceed recommended pressures. Always check pressure with the pressure gauge. Never leave the Air Compressor/Inflator unattended while in use. Bursting articles can cause serious injury.**

### ⚠ CAUTION

**Do not operate the Air Compressor/Inflator continuously for extended periods of time (approx. 15 minutes, depending on the ambient temperature), as it may overheat. In such event, the Air Compressor will shut down and can be restarted after a cooling period of approximately 15 minutes.**

### Inflating Products With a Valve Stem Using the Compressor

1. Place the standard connector (chuck) of the Air Compressor Hose on the valve stem.
2. Push connector toward valve stem and close thumb latch.

**Note: Make sure connector is pushed onto valve stem as far as possible before closing thumb latch.**

3. Slide Air Compressor/Inflator Switch to COMPRESSOR.



4. Monitor the pressure gauge. When desired pressure is reached, slide the Air Compressor/Inflator Switch to OFF; open thumb latch and remove connector from valve stem.
5. Store the compressor hose and tire fitting in storage compartment.

## Inflating Products Without a Valve Stem Using the Compressor

Inflation of other items requires use of one of the adapters (nozzles).

1. Insert appropriate adapter (e.g. needle) into the connector (chuck) on the Air Compressor Hose and close thumb latch.
2. Insert adapter (e.g. needle) into item to inflate.
3. Slide Air Compressor/Inflator Switch to COMPRESSOR.
4. Refer to the following table for approximate filling pressure and time. Small items such as volleyballs, footballs, etc. inflate very rapidly.
5. Monitor the pressure gauge. When desired pressure is reached, slide the Air Compressor/Inflator Switch to OFF; open thumb latch and remove connector from valve stem.
6. Remove adapter from item and store properly.

### Typical Inflation Times

	Inflation pressure (psi)	Approx. Filling time
<i>Vehicle and trailer tires</i>		
155/80R 13"	26	2.5 min.
185/70R 14"	30	4.5 min.
235/75R 16"	30	6.5 min.
235/70R 17"	42	16 min.
<i>Bicycle tires</i>		
27" X 1" (racing)	90	40 sec.
Football	13	24 sec.
Basketball	10	20 sec.
Volleyball	5	6 sec.

### ⚠ WARNING

**Always follow tire manufacturer's recommendations for pressure on item to be inflated.**

**Note:** *Thermo-protection device shuts down the unit when the unit overheats and restarts once the unit has reached a safe operating temperature (usually 15 minutes).*

## Using the Inflator/Deflator

### Inflating

1. Locate the inflation valve on your product and open it.
2. Fasten the Inflator/Deflator Hose (stored in the compartment on the back of the unit — see page 2) to the **Inflator Port** inside the Air Panel.
3. Attach the appropriate nozzle to the free end of the Inflator/Deflator Hose.
4. Slide the Air Compressor/Inflator Switch to INFLATOR.
5. When product is fully inflated, turn the Air Compressor/Inflator Switch to OFF, remove hose from valve and close the valve.

### Deflating

1. Open the valve on your product completely to release air.
2. Fasten the Inflator/Deflator Hose (stored in the compartment on the back of the unit — see page 2) to the **Deflator Port** inside the Air Panel.
3. Attach the appropriate nozzle to the free end of the Inflator/Deflator Hose.
4. Slide the Air Compressor/Inflator Switch to INFLATOR.
5. When product is fully deflated, turn the Air Compressor/Inflator Switch to OFF, remove hose from valve and close the valve.

## CARE AND MAINTENANCE

### ⚠ CAUTION

**If the cord, wires, or cables become damaged, return the entire unit to Power On Board immediately for service/repair.**

### Replacement Parts

For replacement parts (bulbs, batteries, fuses, adapters, hoses, etc.), contact Customer Service, toll-free, at at (954) 584-4446 or toll free at (866) 584-5504.

### Battery Replacement/Disposal

It is recommended that the unit be returned to Customer Service for battery replacement.

This unit contains a maintenance-free, non-spillable, sealed lead-acid battery. This battery is fully recyclable and should be accepted at any location that accepts common automotive batteries. Examples of places that accept these batteries are: county or municipal recycling drop-off centers, scrap metal dealers and retailers who sell automotive replacement lead acid batteries.



### ⚠ WARNINGS

**Do not dispose of the battery in fire, as this may result in an explosion.**

**Before disposing of the battery, protect exposed terminals with heavy-duty electrical tape to prevent shorting (shorting can result in injury or fire).**

**Do not expose battery to fire or intense heat, as it may explode.**

### Fuse Replacement (DC Accessory Adapter)

1. Remove plug from accessory outlet. Remove the gold cap by turning counter-clockwise and lifting off.
2. Remove center pin and spring. Remove fuse.
3. Replace fuse with same type and size fuse (8 amp).
4. Replace center pin and spring inside plug.
5. Replace gold cap by turning clockwise.

## **SPECIFICATIONS**

### **12 Volt DC Specifications**

Battery:	12 volt DC rechargeable, maintenance-free
Internal Battery Type:	Sealed, AGM lead-acid
Internal Battery Capacity:	12 volt, 19Ah/20 hour rate
Area Light :	Light Emitting Diode (LED)
Jumper Cables:	Heavy duty welding cable with 450 amp clamps
Accessory Outlet Protection:	Self-resetting overload protection
DC Charging Adapter:	12 volt DC

### **AC Power Specifications**

Output Power:	Continuous — 400 watts
Output Voltage:	120 VAC RMS
Output Frequency:	60 Hz $\pm$ 4 Hz
Output Waveform:	Modified sine wave
Overheat Protection:	Yes
Overload Protection:	Yes
Output Short Circuit Protection:	Yes

### **Tire Inflator Specifications**

Maximum Pressure:	120 PSI
-------------------	---------

### **Battery Charger Specifications**

Input:	120 volt AC, 60 Hz
Rapid Charging Current:	12 volt DC 1000mA



## Free Manuals Download Website

<http://myh66.com>

<http://usermanuals.us>

<http://www.somanuals.com>

<http://www.4manuals.cc>

<http://www.manual-lib.com>

<http://www.404manual.com>

<http://www.luxmanual.com>

<http://aubethermostatmanual.com>

Golf course search by state

<http://golfingnear.com>

Email search by domain

<http://emailbydomain.com>

Auto manuals search

<http://auto.somanuals.com>

TV manuals search

<http://tv.somanuals.com>