

# COMDIAL®

## DXP, DXP *Plus*, and FX Series Digital Communications Systems

*Impact*  
SCS

### Large Screen Speakerphone Reference Manual

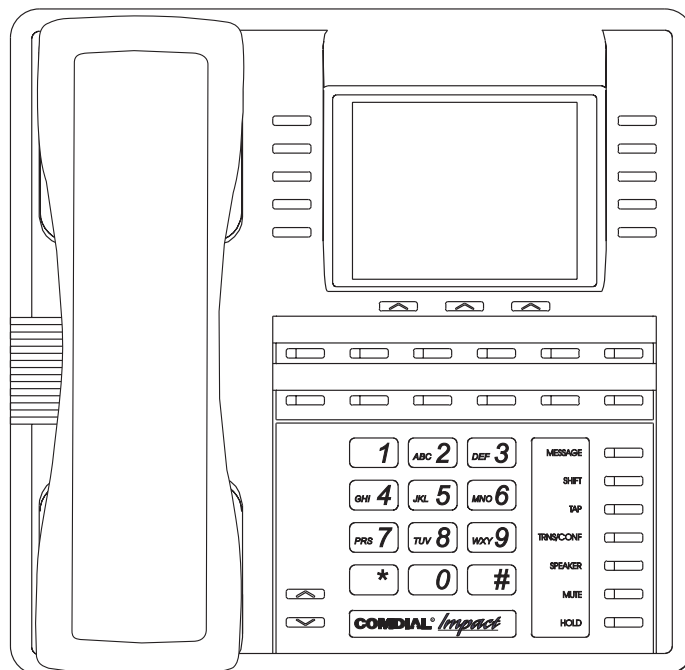

This reference manual applies to the following system and telephone models:

**System Models:**

- DXP systems with software 13A and later.
- DXP *Plus* systems with software 13A and later.
- FX Series with software 13A and later.

**Telephone Models:**

- Impact SCS 8412F-\*\* Rev. A and later.
- Impact SCS 8412S-\*\* Rev. A and later.

Contact your Comdial dealer for updates of this as well as other Comdial publications.



\* Tri-Level Compression is a registered trademark of ACS Wireless, Inc.

Comdial® strives to design the features in our communications systems to be fully interactive with one another. However, this is not always possible, as the combinations of accessories and features are too varied and extensive to insure total feature compatibility. Accordingly, some features identified in this publication will not operate if some other feature is activated.

Comdial® disclaims all liability relating to feature non-compatibility or associated in any way with problems which may be encountered by incompatible features. Notwithstanding anything contained in this publication to the contrary, Comdial® makes no representation herein as to the compatibility of features.

2/12/97

## Contents

<b>1</b>	<b>Introducing The LCD Speakerphone . . . . .</b>	<b>1-1</b>
1.1	Using This Guide . . . . .	1-1
1.2	Using Your Speakerphone . . . . .	1-3
1.3	Using Your Headset . . . . .	1-8
1.4	Understanding The Large Screen Display . . . . .	1-9
1.5	Understanding The Display Abbreviations . . . . .	1-10
1.6	Knowing Your Speakerphone's Functions . . . . .	1-13
1.7	Understanding What The Lights Mean . . . . .	1-15
1.8	Adjusting The Telephone Pedestal . . . . .	1-17
<b>2</b>	<b>Answering Calls . . . . .</b>	<b>2-1</b>
2.1	Answering Outside Calls . . . . .	2-1
2.2	Answering Intercom Calls . . . . .	2-2
2.3	Answering Calls at Monitored Stations . . . . .	2-3
2.4	Answering Night-Transferred Calls . . . . .	2-4
2.5	Making A Call Pick-Up . . . . .	2-5
2.6	Responding To A Subdued Off-Hook Voice Announcement . . . . .	2-6
<b>3</b>	<b>Making Calls . . . . .</b>	<b>3-1</b>
3.1	Dialing Manually . . . . .	3-1
3.2	Dialing Automatically . . . . .	3-2
3.3	Using Dial By Name . . . . .	3-3
3.4	Redialing A Previously Dialed Number . . . . .	3-4
3.5	Using Line Groups . . . . .	3-8
3.6	Waiting For A Line (Queuing) . . . . .	3-9
3.7	Making Intercom Calls . . . . .	3-10
3.8	Camping On At A Busy Station and Waiting For An Automatic Callback . . . . .	3-11
3.9	Camping On At An Idle Station and Waiting For An Automatic Callback . . . . .	3-12
3.10	Camping On At A Busy Station And Waiting For An Answer . . . . .	3-12
3.11	Overriding A Call Or A Do Not Disturb Condition At Another Telephone . . . . .	3-13
3.12	Making A Subdued Off-Hook Voice Announcement (SOHVA) . . . . .	3-14

<b>4</b>	<b>Placing Calls On Hold</b> .....	<b>4-1</b>
4.1	Holding Calls .....	4-1
4.2	Handling Hold Recalls .....	4-4
4.3	Parking Calls .....	4-5
4.4	Handling Park Recalls .....	4-6
<b>5</b>	<b>Transferring Calls</b> .....	<b>5-1</b>
5.1	Transferring Calls—Screened .....	5-1
5.2	Transferring Calls—Unscreened .....	5-3
5.3	Making A Hot Transfer .....	5-4
5.4	Transferring Calls Using Quick Transfer .....	5-5
<b>6</b>	<b>Conferencing Calls</b> .....	<b>6-1</b>
6.1	Conferencing Telephones Together .....	6-1
<b>7</b>	<b>Using The Other Telephone Features</b> .....	<b>7-1</b>
7.1	Adjusting The Display Contrast .....	7-1
7.2	Blocking Voice-Announce Calls .....	7-1
7.3	Displaying Status Of Busy Lines And Stations (Busy Button Inquiry) .....	7-2
7.4	Displaying Button Functions (Button Query) .....	7-3
7.5	Diverting Incoming Calls To Another Station .....	7-3
7.6	Entering Account Codes .....	7-4
7.7	Entering Authorization Codes .....	7-5
7.8	Forwarding Calls .....	7-6
7.9	Listening To A Call Over The Telephone Speaker .....	7-7
7.10	Making A Call Non-Private (Privacy Release) .....	7-8
7.11	Monitoring A Conversation Between Two Telephones (Service Observing) .....	7-9
7.12	Muting Your Telephone .....	7-10
7.13	Sending A Paging Announcement .....	7-10
7.14	Setting A Do Not Disturb Condition At Your Station .....	7-12
7.15	Setting The Volume Control .....	7-13
7.16	Setting Your Personal Ringing Tones .....	7-15
7.17	Switching The Dialing Mode Between Pulse And Tone .....	7-16
7.18	Using Background Music .....	7-16

7.19	Using Direct Inward System Access (DISA) . . . . .	7-17
7.20	Using The Tracker Paging System . . . . .	7-20
7.21	Using E And M Tie Lines . . . . .	7-23
7.22	Call Forward Outside System . . . . .	7-25
7.23	Mark Problem Line . . . . .	7-27
7.24	Automatic Set Relocation . . . . .	7-28
7.25	Using The IMIST Module . . . . .	7-29
7.26	Using The Caller ID Feature . . . . .	7-30
7.27	Viewing The Call Log . . . . .	7-31
<b>8</b>	<b>Sending And Receiving Non-Verbal Messages. . . . .</b>	<b>8-1</b>
8.1	Message-Waiting Light And Messaging . . . . .	8-1
8.2	Sending LCD Messages . . . . .	8-3
8.3	Sending Response Messages . . . . .	8-5
<b>9</b>	<b>Programming Your Telephone . . . . .</b>	<b>9-1</b>
9.1	Programming For Speed Dialing . . . . .	9-1
9.2	Storing Speed Dial Numbers . . . . .	9-3
9.3	Storing DSS Numbers . . . . .	9-4
9.4	Using The Feature Buttons . . . . .	9-5
9.5	Storing A Response Message Button . . . . .	9-7
9.6	Storing Access Codes . . . . .	9-8
9.7	Setting A Reminder Alert . . . . .	9-9
<b>10</b>	<b>Using The Attendant Features. . . . .</b>	<b>10-1</b>
10.1	Using The Special Attendant Buttons . . . . .	10-1
10.2	Viewing The System Status Log . . . . .	10-4
10.3	Operating Your Telephone With A DSS/BLF Console. . . . .	10-6
<b>11</b>	<b>Troubleshooting Your Telephone . . . . .</b>	<b>11-1</b>
	<b>Index . . . . .</b>	<b>Index-1</b>
	<b>Quick Reference Guide . . . . .</b>	<b>Quick Reference-1</b>

*This page remains blank intentionally.*



# ***Introducing The Large Screen Speakerphone***

---

## **1.1 Using This Guide**

This user's guide describes your large screen speakerphone and tells you how to use it.

The sections in this introductory chapter help you become familiar with your speakerphone's controls and indicators. The remaining sections are titled as follows:

- 1.2 Using Your Speakerphone
- 1.3 Using Your Headset
- 1.4 Understanding the Display Abbreviations
- 1.5 Knowing Your Speakerphone's Functions
- 1.6 Understanding What The Lights Mean

The operation chapters define often-used features and provide instructions for their use. These chapters are titled as follows:

- 2 Answering Calls**
- 3 Making Calls**
- 4 Placing Calls On Hold**
- 5 Transferring Calls**
- 6 Conferencing Calls**

The special-purpose features of the telephone are grouped into one chapter:

- 7 Using The Other Telephone Features**

Your telephone provides several non-verbal ways to communicate using lights and indicators. The descriptions of these methods are provided in a separate chapter:

**8 Sending And Receiving Non-Verbal Messages**

You can program many of the buttons on your telephone to enhance the unit's versatility and usability. These programming instructions are found in the following chapter:

**9 Programming Your Telephone**

For your convenience, a troubleshooting chart is provided in the following chapter:

**10 Using The Attendant Features**

If you operate an attendant station, you will use the special features provided in the following chapter:

**11 Troubleshooting Your Telephone**

There is a quick reference chart in the following chapter:

**Appendix A  
Quick Reference Guide**



## **1.2 Using Your Speakerphone**

When using your speakerphone, the microphone and loudspeaker are farther away from you than when you use a handset. Both the signal from the loudspeaker and the signal to the microphone must be strengthened. When microphones and loudspeakers are close together (such as in a speakerphone), additional amplification typically generates a ringing sound (public address systems do this if the volume is too high or the microphone is too close to a loudspeaker).

***NOTE: The 8412F-\*\* speakerphone can function in the full-duplex or half-duplex mode. Both sets of guidelines (section 1.2.1 and section 1.2.2) are applicable to the 8412F-\*\*. The 8412S-\*\*, however, can only function in half-duplex mode. Only the guidelines in section 1.2.2 are applicable to the 8412S-\*\*.***

### **1.2.1 Full-Duplex Speakerphone Guidelines**

The *Impact SCS* 8412F-\*\* speakerphone uses the latest full-duplex speakerphone technology. (Full-duplex technology enables both parties on a speakerphone call to speak simultaneously—half-duplex speakerphones carry only one person’s voice at a time.) The 8412F-\*\* will operate in either full-duplex or half-duplex mode depending on the current line conditions. For example, satellite calls or calls with a delay involved may prevent the telephone from operating in full-duplex mode.

To operate in full-duplex mode, the telephone must perform a “speech training” test at the beginning of each call. To achieve optimum performance from the full-duplex speakerphone, Comdial recommends that each user in turn speak about 10 consecutive words to allow the telephone to “train” itself. Note that during the “speech training” test, the speakerphone is operating in half-duplex mode.

Depending on the telephone line conditions and the type of speakerphone at the other end, it may not be possible for the 8412F-\*\* to operate in full-duplex mode. If the speakerphone at the other end is a half-duplex speakerphone and both parties are in speakerphone mode, the half-duplex speakerphone is the controlling factor, preventing the 8412F-\*\* from operating in full-duplex mode.

***NOTE: Pressing any button (mute, hold, etc.) on the speakerphone while in full-duplex mode causes the system to perform the “speech training” test again. For example, if you press MUTE while in full-duplex mode, when you release the call from mute, the system will perform the entire “speech training” test.***

Depending on telephone line conditions and the type of speakerphone the distant party is using, it may not be possible for the 8412F speakerphone to operate in full-duplex mode. If the distant party's speakerphone is a half-duplex model and both you and the distant party are in speakerphone mode, the half-duplex speakerphone controls the communications mode and prevents the 8412F from operating in full-duplex mode.

To maximize the usefulness of your full-duplex speakerphone, take note of these following observations about full-duplex speakerphone operation.

- The full duplex operating mode requires a small amount of time to adapt to changes in echo; therefore, you should avoid making any movements in the vicinity—about a one-foot radius—of the speakerphone.
- There are certain echo limits beyond which the speakerphone cannot effect canceling. These limits are as follows: room echoes beyond 39 milliseconds (standard configuration) and line echoes beyond 24 milliseconds (standard configuration).
- The speakerphone may automatically reduce the volume in each direction when both you and the distant party talk at the same time (double-talk). This volume reduction is necessary to control the echoes at high volume levels. It is possible for surrounding conversations and other sounds to trigger double-talk even when you are not speaking. This condition may lower the loudspeaker volume at your speakerphone.
- You must adjust the loudness of your voice to match that of the distant party's voice. This action is necessary to cause full-duplex operation to take place. Sustained double-talk or excessive echo may cause the speakerphone to drop back into half-duplex operation. This happens because the speakerphone's echo cancel circuits cannot adapt during the double-talk situation.
- If both you and the distant party are using full-duplex speakerphones, the sensitivity to both echo path changes and volume reduction during double-talk is doubled from the sensitivity when just one full-duplex speakerphone is involved.

### **1.2.2 Half-Duplex Speakerphone Guidelines**

***NOTE: The speakerphone user guidelines in this section do not apply to the Impact SCS 8412F-\*\* when it is operating in full-duplex mode. However, when the 8412F-\*\* is in half-duplex mode or in “speech training” mode, the following guidelines are applicable.***

***These guidelines are also applicable to the 8412S-\*\* whenever it is in speakerphone mode.***

- Background noise may prevent the sound-activated switches from operating properly. Avoid placing the speakerphone where it will detect sounds from typewriters, keyboards, printers, paging systems, and other equipment.
- Speak slightly louder than normal and in a clear voice. For the microphone to best detect your voice, speak within three feet of it and face the telephone.
- Raising the volume of the loudspeaker makes it easier for the sound-activated switches in your telephone to select the distant party’s voice. Lowering the volume of the loudspeaker makes it easier for the switches to select your voice.
- Since the system takes several seconds to provide the best switching, constant sound patterns—such as elongating your words and playing externally-supplied music—may prevent the sound-activated switches from operating properly.
- Place the telephone on a hard surface and away from table edges. Do not place the telephone in corners or enclosures. Do not let obstructions come between you and the microphone. Rooms with hard, flat surfaces that reflect sound may affect the sound-activated switches.
- If you are using a handset and the other party is using a speakerphone, avoid breathing heavily into your microphone. Avoid other sounds that may affect the distant telephone’s sound-activated switches.
- In some situations, such as when either you or the distant party is in a noisy environment, you may have to lift your handset to ensure a clear conversation.

- To manually place a call using your speakerphone,
  1. Press the **INTERCOM** or line button.
  2. Dial the number.
  3. When party answers, speak toward the telephone.
- To automatically dial a number using your speakerphone,
  1. Press the preprogrammed speed dial or DSS button and speak toward the telephone when your party answers.
- To answer a call with your speakerphone,
  1. Press the **INTERCOM** or line button with flashing red or orange light.
  2. Speak toward the telephone to answer the call.
  3. To end a call with your speakerphone, just press **SPEAKER**.

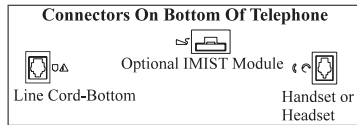
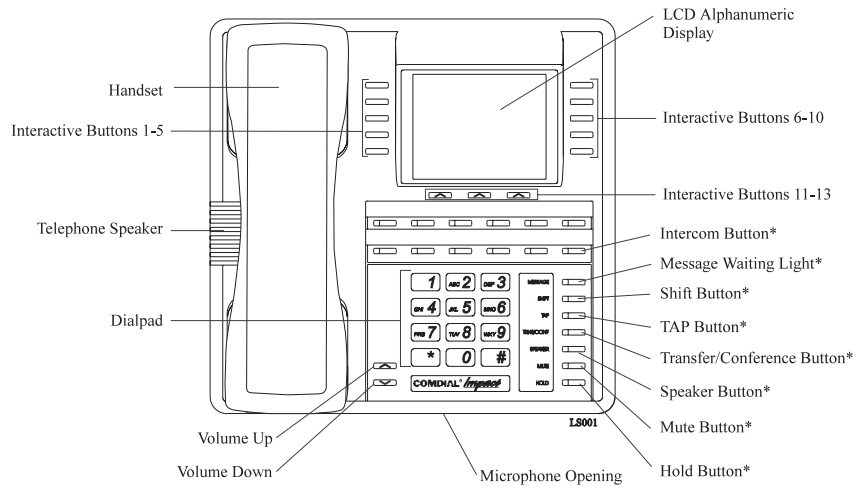

*\*NOTE: These are default button locations.  
Your system installer may have reprogrammed  
these buttons to better suit your application.*

### **1.3 Using Your Headset**

***NOTE: The Comdial Impact SCS-AM and Impact SCS-AB headsets are designed for use with the Impact SCS 8412F-\*\* and 8412S-\*\* speakerphones. Comdial authorizes only these headsets for use with the Impact SCS line of telephones.***

If you install the optional headset on your telephone, you will be able to quickly switch between handset and headset use with the “quick disconnect” cord supplied with your headset.

- To install the Comdial headset,
  1. Turn your telephone over and locate the handset/headset jack on the bottom of the telephone.
  2. Unplug the handset cord from its modular jack and remove the cord from its routing channel.
  3. Plug the quick disconnect cord into the modular handset/headset jack on the bottom of the telephone and route it through the routing channel. (Make sure the section of cord you plug into the telephone jack has the female receptor jack.)
  4. Plug the male end of the headset cord into the female end of the quick disconnect cord.
  
- To switch from headset operation to handset operation,
  1. Unplug the handset cord from the modular jack in the handset.
  2. Plug the quick disconnect cord into the modular jack on the handset. (Make sure the section of cord you plug into the handset jack has the male part of the quick disconnect jack.)
  3. Disconnect the male connector of the headset at the quick disconnect plug.
  4. Plug the male end of the handset cord into the female end of the quick disconnect cord.

## **1.4 Understanding The Large Screen Display**

Your speakerphone has a large screen display consisting of six lines of 24 possible character positions per line. This provides you with much more system information than can be presented on two-line displays. This large display allows you many programming options as well as quick and easy selection of the many features available on your speakerphone. Your speakerphone has 13 interactive buttons for selecting or programming features.

When your speakerphone is idle, the first line in your display shows the date and time while the sixth line displays the word **OPTIONS**. If your system is using the voice mail option, this is also indicated in the sixth line by the word **VMAIL**. If your voice mail has four messages for you, for example, the **VMAIL** display is replaced by **4 MSG**.

Lines two through four are used on the idle display to indicate features that may be active (flashing), enabled or set.

## ***1.5 Understanding The Display Abbreviations***

This chart identifies the interactive button abbreviations that appear in your display.

<b>Feature</b>	<b>Definition</b>
<b>Account Code</b>	Stores a button that enables account code entry.
<b>Answer</b>	Answers a call ringing at your station.
<b>Auto Redial</b>	Redials a busy call once a minute for 10 minutes.
<b>Background Music</b>	Turns on the background music at your station. When chosen as a feature, stores a button that enables the function.
<b>Button Query</b>	Displays program status of any button.
<b>Call</b>	Calls a station that turned on your message waiting light.
<b>Camp On</b>	Has system call you when busy station becomes idle. When chosen as a feature, stores a button that enables the function.
<b>Call Forward</b>	Forwards all of your calls to a different station location. When chosen as a feature, stores a button that enables the function.
<b>Clear Features</b>	Stores a button that clears a currently active or engaged feature.
<b>Conference</b>	Establishes a conference.
<b>DND (Do Not Disturb)</b>	Makes your station appear busy to other stations. When chosen as a feature, stores a button that enables the function.
<b>DSS (Direct Station Select)</b>	Stores a personal intercom number at a DSS button.
<b>Forward Personal</b>	Route your personal intercom calls to a different station location.



<b>Feature</b>	<b>Definition</b>
<b>Erase</b>	Use to delete an incorrect entry when programming a speed dial number.
<b>Exit</b>	Ends a current programming session.
<b>Feature Button</b>	Presents several different features you can store at programmable buttons for later use.
<b>Forward All</b>	Route all of your calls to a different station location.
<b>Forward RNA All</b>	Forwards all ring—no answer calls.
<b>Forward RNA Personal</b>	Forwards only personal intercom ring—no answer calls.
<b>Group Listen</b>	When chosen as a feature, stores a button that enables loud speaker broadcast of distant party's voice.
<b>Message</b>	Turns on message waiting light at another station.
<b>Music Source</b>	Selects which music source will supply background music.
<b>Next</b>	Shows the next display.
<b>Options</b>	Selects interactive button features.
<b>Override</b>	Overrides either a do-not-disturb condition or a busy signal at a station you have called.
<b>Paging Zone</b>	When chosen as a feature, stores a button that provides one-button access to paging.
<b>Park Orbits</b>	When chosen as a feature, stores a button that provides one-button parking of calls.

<b>Feature</b>	<b>Definition</b>
<b>Pick Up Direct</b>	When chosen as a feature, stores a button that allows you to pick up a call ringing your intercom line.
<b>Pick Up Group</b>	When chosen as a feature, stores a button that allows you to pick up any call ringing in your intercom group.
<b>Privacy Release</b>	When chosen as a feature, stores a button that releases privacy for a current call.
<b>Reconnect</b>	Reconnect you to a transferred call.
<b>Reminder Alert</b>	Sets two reminder alerts that will sound at your station at specified times.
<b>Ring Tone</b>	Select different ringing tones.
<b>Save Number Redial</b>	Permanently saves last number you dialed. When chosen as a feature, stores a button that provides the function.
<b>Send Transfer</b>	Re-transfers a previously transferred call that returned to your station.
<b>Subdued Off-Hook Voice Announce</b>	Sends a subdued off-hook voice announcement to another station.
<b>Speeddial</b>	Programs a number for one-button calling.
<b>Take A Message</b>	Send a non-verbal response to a SOHVA caller so he or she will know to take a message from an outside party.
<b>Voice Announce Block</b>	Inhibits your station from receiving a SOHVA. Also, blocks voice calls sent over the speaker. When chosen as a feature, stores a button that provides the function.

## **1.6 Knowing Your Speakerphone's Functions**

Your speakerphone provides many versatile features for your use. These features are explained in terms of what they allow you to do. Refer to section 1.5 *Understanding What The Lights Mean* for information about the lights associated with your telephone's buttons.

### **Alphanumeric Display (Liquid Crystal Display—LCD)**

- Displays time, day, date, and active call information
- Keeps you apprised of the status of your telephone
- Provides programming prompts

### **Hold Button**

- Places a line or intercom call on hold
- Stores pauses in number sequences during programming
- Scans or scrolls through calls placed on hold (when hold light is flashing) in order to access, with the TAP button, a call other than the last one placed on hold (information about each held call appears in your display as you scroll through them)
- Scrolls through LCD response messages

### **Interactive Buttons**

- Provide quick and easy access to system features
- Provide straightforward button programming without dialing codes (the interactive buttons themselves, however, are not programmable)

### **Intercom Button**

- Selects an intercom line
- Allows you to initiate many of the telephone's features

### **Message-Waiting Light**

- Indicates that a message awaits pick up

### **Microphone Opening**

- Allows hands-free operation of speakerphone (speak clearly toward microphone opening)

### **Mute Button**

- Keeps the person on the line from hearing your conversation

### **Programmable Buttons And Associated Status Lights**

- Allow you to store numbers for automatic dialing functions
- Allow you to store telephone extension numbers for Direct Station Selection (DSS)
- Indicate which lines are either in use, ringing, or on hold

### **Shift Button**

- Allows you to enter a second tier for storing and/or automatically dialing speed dial numbers. That is, you can store two speed dial numbers at every programmable button location—one in the regular tier and one in the second tier. You activate the shift function by pressing this button and turning the shift light on before storing or automatically dialing a speed dial number from the second tier.

### **Speaker**

- Sounds distant party's voice
- Sounds ringing and call-in-progress tones

### **Speaker Button**

- Turns your speaker on or off
- Disconnects a call when you are on a handsfree call
- Ends or cancels programming

### **TAP Button**

- Recalls dial tone or generates a hookflash
- Retrieves held calls or last call placed on hold

**Transfer/Conference Button**

- Transfers calls
- Sets up conference calls

**Volume Control**

- Regulates the volume of the ringer, speaker, handset, headset, background music, and group listening mode

**1.7 Understanding What The Lights Mean**

The lights (LEDs) on your LCD speakerphone indicate the status of lines, features, and intercoms.

**Next to a Direct Station Select (DSS) button:**

- Steady red = station is in use.
- Flashing red = station is receiving a call.
- Winking red with repetitive off = message-waiting light set for you by station associated with that DSS button.

**Next to a line button:**

- Steady green = this is your line, either on-hook (in a handsfree mode) or off-hook, when the line is active.
- Steady red = another station is using this line.
- Flashing red = a call is coming in on this line.
- Flashing orange = this line will be answered when you lift the handset.
- Winking green with repetitive off periods = your line is on hold.
- Winking red = the call has been placed on hold by another station.
- Fluttering orange = your line has recalled from hold.
- Fluttering red = the line put on hold by another station has recalled.

**Next to a fixed feature or programmable feature button:**

- Steady red = the feature is on.
- Steady off = the feature is off.

**Next to an intercom button:**

- Steady green with a quick flash = you are using your intercom.
- Fluttering red = an LCD message is set on your telephone for others to receive when calling.
- Flashing orange = someone is calling your extension or a call is being transferred to you.

**Next to the HOLD button:**

- Fast flashing red = message awaits pick up.
- Winking green with repetitive off periods = a line is on hold at your station.

**Next to the SPEAKER button:**

- On steady (with the telephone on hook and busy) = speakerphone mode is active.
- On steady (with telephone on hook and idle) = background music is turned on.
- Flashing = feature viewing and programming is in progress.

**Next to the MUTE button:**

- On steady = other party cannot hear your conversation.

## 1.8 Adjusting The Telephone Pedestal

Your telephone has an adjustable pedestal to allow you to select the most comfortable viewing angle. When you receive the telephone, the pedestal is in its lowest position—flush against the pedestal.

- To adjust the pedestal,
  1. Grasp the rear of the pedestal base firmly with one hand while lifting the rear portion of the telephone upward with your other hand
  2. While pivoting the telephone upward with one hand, pivot the telephone supporting arms upward with your other hand while feeling for the notches under the telephone. Notice there are three sets of notches under the telephone corresponding to the three positions available.
  3. When the telephone is at the desired height, find the closest pair of notches and place the supporting arms in the notches. Press down slightly on the telephone until you feel the supporting arms snap into place.

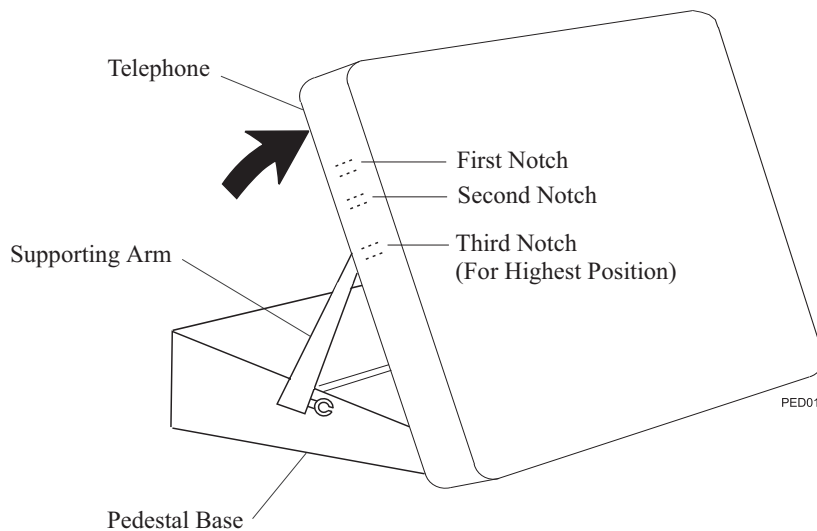

Adjusting The Pedestal

*This page remains blank intentionally.*



# 2

## Answering Calls

**NOTE:** *Throughout this book, all references to fixed buttons are printed in upper case bold type, for example “Press the INTERCOM button.”*

*All references to interactive buttons are printed in upper case bold italic type, for example “Press the OPTIONS button.”*

### 2.1 Answering Outside Calls

A call that rings on an outside line will sound long, single-tone bursts and will light the line status light. If the installer enabled ringing line preference at your station, an orange light flashes next to the line that your station will answer when you lift the handset; a red light will flash for any other ringing line.

- When you hear outside ringing and observe a flashing light, answer the call as follows:
  1. Lift handset or press line button and speak toward telephone if light is orange,  
—OR—  
press button of ringing line if flashing light is red, and speak toward the telephone (lift handset if privacy is desired).

When a call rings at your station, the ringing line number or name appears in the display along with the options **ANSWER** and **DO NOT DISTURB**.

- To answer the call for which information appears in your display,
  1. Press **ANSWER**. (Pressing **DO NOT DISTURB** stops your telephone from ringing but continues to send a ringing tone to the caller). The associated BLF will continue to flash until the caller disconnects.

- After you have answered an outside call at your station, your LCD will display **HOLD**, **TRANSFER**, and **CONFERENCE**:
  1. Press **HOLD** to place the call on hold at your station,  
—OR—  
press **TRANSFER** to initiate a transfer to another station, then dial the station number, announce the call or hang up to complete the transfer,  
—OR—  
press **CONFERENCE** to initiate a conference call.

## **2.2 Answering Intercom Calls**

An intercom call is one that is made from one system telephone to another. An intercom party can voice-announce through your speaker instead of ringing your telephone, or an intercom party can ring your telephone (intercom ringing sounds two short ring bursts).

You can block voice-announce calls if you wish. See the discussion titled *Blocking Voice Announce Calls* for details.

- When you hear intercom ringing followed by a caller's voice,
  1. Speak toward the telephone to answer, or lift handset if privacy is desired.
- When you hear intercom ringing (two short ring bursts),
  1. Press **INTERCOM** and speak toward telephone; lift handset if privacy is desired.

When an intercom call rings at your station, the number or name of the originating station appears in the display, along with the options **ANSWER** (Answer) and **DO NOT DISTURB**.

- To answer the call for which information appears in your display,
  1. Press **ANSWER**. (Pressing **DO NOT DISTURB** stops the ringing, sets a Do Not Disturb condition at your telephone, and sends a Do Not Disturb tone to the caller. The intercom light continues to flash).

## **2.3 Answering Calls At Monitored Stations**

Your telephone may have the personal intercom number of another telephone appearing at a button location. You can use the light associated with this button to monitor the status of that telephone, and you can press the button to make a call to that telephone if you wish. The associated light is known as the Busy Lamp Field (BLF) light, and the button is known as the Direct Station Select (DSS) button.

If the installer arranged for your telephone to have the station monitoring feature, the BLF light shows activity status at the monitored telephone.

- To monitor another telephone,
  1. Observe the BLF light indications next to the personal intercom appearance (DSS) button:
    - Off = idle,
    - Flashing = ringing,
    - On = busy or on hold.

***NOTE: If you do not have the station monitoring feature, the BLF light shows just the following information: Off = idle, On = busy.***

- To call an idle monitored station or to answer one that is ringing,
  1. Note the BLF light condition.
  2. Press assigned DSS button.
  3. Lift the handset to talk.

***NOTE: If you place this call on hold or if you transfer it to another telephone, the BLF light flashes a hold signal. You can retrieve the call by pressing TAP.***

## **2.4 Answering Night-Transferred Calls**

The system attendant can transfer incoming calls to a particular station or stations for off-hour ringing. Additionally, the installer can program the system for night-answer zones (up to four) with a loud bell associated with each zone. The loud bell sounds when the night transfer of ringing feature directs incoming calls to a zone. The installer may choose different night-answer dialing codes than those default values detailed in this procedure. When in doubt, ask your system attendant what codes are active at your site.

- If your telephone rings,
  1. Press line button with flashing light.
  2. Lift handset to talk.
  
- When you hear loud ringing anywhere in the system,
  1. Lift handset.
  2. Press **INTERCOM**.
  3. Dial **65** through **68** to select ringing zone (1-4) that the bell is in,  
—OR—  
dial **69** to answer any ringing zone.

***NOTE: This feature is known as Trunk Access From Any Station (TAFAS).***

## 2.5 Making A Call Pick-Up

The installer often arranges several telephones together in a user group. If your telephone is so arranged, you can answer calls that are ringing at other stations within your particular group. Also, you can answer a call that is ringing at any telephone in the system if you know the telephone's extension number.

- To answer a call that is ringing within your group,
  1. Press **INTERCOM**.
  2. Dial # **4**.
  3. Speak toward telephone to answer call. Lift handset if privacy is desired.
- To answer a call that is ringing at any telephone in the system,
  1. Press **INTERCOM**.
  2. Dial \* **4**.
  3. Dial extension number of ringing telephone.
  4. Speak toward telephone to answer call. Lift handset if privacy is desired.

If you have programmed a **PICK UP** button on your telephone (see "Storing The Feature Buttons" in the chapter titled *Programming Your Telephone* in this guide), you may make a call pick-up (either within your group or at a specific station inside or outside your group) using that button.

- To answer a call ringing at any other station in your group,
  1. Press preprogrammed group **PICK UP** button.
- To answer a call ringing at a specific station (either inside or outside your group),
  1. Press preprogrammed direct **PICK UP** button.
  2. Press DSS or dial extension of ringing telephone.

## 2.6 *Responding To A Subdued Off-Hook Voice Announcement*

---

Your installer can set your LCD speakerphone to receive a Subdued Off-Hook Voice Announcement (SOHVA). This feature allows an intercom caller to break into your call by making an announcement through your handset receiver. (This means that if you are on a speakerphone call, you cannot receive a SOHVA call.) The distant party that you are currently talking to cannot hear the announcement made by the SOHVA caller.

Please note that you can receive a SOHVA call even if you are using your headset; however, the distant party may be able to hear the SOHVA as it is made.

- You can respond to a SOHVA in one of three ways:
  - **Verbally:** Press and hold the **REPLY** button and speak into handset. Distant party cannot hear response. To return to distant party after your reply is complete, release the **REPLY** button.
  - **Non-verbally (Response Messaging):** If the announcing station has an LCD speakerphone, press **MESSAGE**, then select one of the messages appearing in your LCD by pressing the corresponding interactive button. The message you select appears in the display of the telephone making the SOHVA call and then that telephone is automatically disconnected from your telephone. (If the telephone to which you attempt to send a non-verbal message is not an LCD telephone, no message is sent and that station is immediately disconnected from the call.)
  - **Blocking the SOHVA:** You can block a SOHVA to your station by pressing **BLOCK** when the SOHVA is initiated. The SOHVA call is then disconnected.

**3****Making Calls****3.1 Dialing Manually**

You can manually dial a number over any telephone line you select. Or, if the installer assigned a prime line or the idle line preference feature to your LCD speakerphone, it will automatically select a line for use when you lift the handset.

- To dial an outside number manually,
  1. Press line button to select line (remember: selecting a line is not necessary if a prime line or idle line preference feature is assigned to your telephone and if you lift the handset or press **SPEAKER** to begin the call).
  2. Listen for dial tone.
  3. Dial number.
  4. Lift handset if privacy is desired.

### **3.2 Dialing Automatically**

This feature provides one- or two-button speed dialing using programmable buttons at which you have previously stored numbers. Two levels of number storage are available at each storage location, and you can use one or both levels as needed. Further, since you usually store a line choice as part of a speed dial number, line selection is automatic with speed dialing. This user's guide discusses button programming in a separate section. Refer to it when you are ready to store numbers at the programmable buttons.

There are two types of speed dial numbers: (1) numbers that you store for your own use (personal speed dial numbers), and (2) numbers that the system attendant stores for everyone's use (system speed dial numbers).

- To automatically dial a speed dial number stored at one of the programmable buttons on your station,
  1. Press preprogrammed speed dial button (line selection is usually a part of the stored speed dial number),  
—OR—  
press preprogrammed **SHIFT** button, then press preprogrammed button (to choose number stored as a second choice at that button).

With your station idle, you can automatically dial a personal or system speed dial number stored at a dial pad location.

- To speed dial a personal speed dial number stored at the dial pad,
  1. While on hook, press speed dial number on dial pad (**0-9**).
- To speed dial a system speed dial number stored at the dial pad,
  2. While on hook, press \* and then dial system speed dial number (**000-999**).

**NOTE:** *If you are already on a line, you must press **SHIFT** before dialing the personal or system speed dial numbers that are stored at the dial pad. Also, if a speed dial's preselected line is in use, the speed dial will not engage.*

**NOTE:** *On some systems, due to site requirements, the available system speed dial codes are \*100-\*299 and \*100-\*599.*



### 3.3 Using Dial By Name

The Dial By Name feature provides an index of names you can search. When you select a name in the index, the system will automatically dial that person's extension number.

- To use Dial By Name,
  1. Press **OPTIONS**, then select either **INTERNAL DIAL BY NAME** button for intercom calling, or **EXTERNAL DIAL BY NAME** button for speed dial calling.
  2. The display shows several letters beside each interactive button.
  3. Press the button next to the letter of the person's name whom you wish to call. The display shows the first existing name match to the letters you selected or shows a **No Name Match** message if the system cannot find a match.

**NOTE: All the names starting with the letters you selected will appear, but they will not be in alphabetical order.**

4. Press **NEXT** to display the subsequent names in the index until you reach the name you need.
5. If the display says **No Name Match**, press **PREV** to return to the list of letters.
6. Press the button next to the name you wish to call  
—OR—  
Press **ALT** to display the corresponding number.
7. Press **CALL** to call the displayed location.  
—OR—  
Press **MESSAGE WAIT** to send an LCD message to the displayed location telling them to call you.  
—OR—  
If Tracker is available, press **TRACK** to track the called person.
8. Press **EXIT** to exit the Dial By Name menu.

### **3.4 Redialing A Previously Dialed Number**

If the last number you have called is busy or is not answering, you can redial it once or initiate automatic redialing. The system will support automatic redialing for up to 10 numbers.

You can permanently save the first 16 digits of the last manually dialed number while on the call by pressing **MORE** then pressing the **SAVE** interactive button or by using a **SAVED NUMBER REDIAL** button that you or your system installer has preprogrammed.

If a distant party tells you an important telephone number and you want to immediately save it for later redial, you can use the **SAVED NUMBER REDIAL** button to permanently save the first 16 digits of that number.

You will overwrite a temporary system-saved number with subsequent dialing activity; however, a permanently saved number remains available until you overwrite it by saving a different number at the same storage location.

#### **3.4.1 Redialing The Last-Dialed Number**

- To redial the last-dialed number,
  1. Make sure your telephone is on-hook and idle.
  2. Press #.

### **3.4.2 Using The Automatic Redial Feature**

If your station has the multiple automatic redial feature enabled, you can place up to 10 numbers in your telephone's redial queue. Your telephone will redial the numbers one at a time, in the order you placed them in the queue, until (a) the call is answered, (b) you cancel the automatic redial feature for a particular number, or (c) your telephone has dialed the number a preprogrammed number of times (set by your system installer).

- To use the automatic redial feature to redial a busy or unanswered number,
  1. While on the call, press the **AUTO REDIAL** button.
  2. The system repeatedly dials the number until you cancel the feature by pressing the **CLEAR** button, you perform any activity at your station, or the system has dialed the number a preprogrammed number of times (determined by your system installer).
  3. The LCD displays the words **AUTO REDIAL** and **CLEAR**.
  4. When the distant party answers the call, press the **AUTO REDIAL** button while on the call to cancel automatic redialing,  
—OR—  
if your installer has enabled answer supervision on your line, the system automatically cancels automatic redialing.
  5. If your system installer has enabled the redial multiple numbers feature, you can have up to 10 numbers in your redial queue. To add numbers to your redial queue, repeat step 1 in the above procedure.
- To display numbers in your redial queue if your telephone is currently idle,
  1. Press the **AUTO REDIAL** button.
  2. To remove the number from the redial queue, press **REMOVE**.  
To scroll to the next screen of numbers in the queue, press **NEXT**.  
To exit from the redial queue, press **EXIT**.

- To interrupt the redialing procedure so that you can scroll through numbers in your redial queue,

**NOTE:** *You can only do this if the multiple automatic redial numbers feature is enabled and you currently have more than one number in your redial queue.*

1. While your telephone is in the process of dialing a number, press the **AUTO REDIAL** button. This treats the number as answered, cancels automatic redialing for that number, and puts the number back in the automatic redial queue.  
The display shows the last number dialed.
  2. To remove the number from the redial queue, press **REMOVE**,  
—OR—  
to exit from the redial queue, press **EXIT**.
- To cancel the automatic redial feature,
    1. Perform any user activity at the station (go on-hook, press the speaker button, etc.),  
—OR—  
press # **72** to delete all numbers from the redial queue,  
—OR—  
press the **AUTO REDIAL** button while the number you wish to remove from the redial queue is ringing.

**NOTE:** *The system allows only ten numbers in the redial queue. In order to add a number to a full redial queue, you must first remove one of the numbers from the queue.*

### **3.4.3 Storing Numbers For Redial**

- To permanently store a number you've just dialed,
  1. While the number is still ringing, press the *MORE* button, then press *SAVE*.
  2. Select an *unused* programmable button location.
- To dial the saved number,
  1. Press button where you saved the number.

### **3.5 Using Line Groups**

Some systems have telephone lines arranged into line groups. These line groups are available at each telephone. Your attendant can tell you how your system is arranged. When line groups are available for your use, you may access them for outside calling instead of pressing a line button to select an individual line for use.

- If your system has line groups, access them as follows:
  1. Press **INTERCOM**.
  2. Dial desired line group access code:\*
    - 9** = line group 1
    - 80** through **89** = line groups 2 through 11
    - 60** through **64** = line groups 12 through 16—OR—  
press preprogrammed line group button.
  3. Listen for outside dial tone.
  4. Dial desired number.
  5. Lift handset to talk.

*\* These are the default system codes. Your installer may have reprogrammed them to better suit your application.*

### **3.6 Waiting For A Line (Queuing)**

If all the lines in a line group are busy, you can place your telephone in a queue to await an idle line. When you share a line with another telephone and the line is busy, you can place your telephone in a queue to await the idle line.

- To queue for a line group,
  1. Press **INTERCOM**.
  2. Dial the line group access code.
  3. Hear busy tone.
  4. Dial \* **6**.
- If you have line appearance for a particular line and wish to queue for it,
  1. Note the busy status light (LED).
  2. Press **INTERCOM**.
  3. Dial \* **6**.
  4. Press line button.
  5. When line group is free, your telephone sounds several short tone bursts. When you hear this, lift handset, hear dial tone, and place call.
- To cancel line queuing or line group queuing,
  1. Press **INTERCOM**.
  2. Dial # **6** and hang up.

### 3.7 Making Intercom Calls

You can dial an intercom extension manually from the dial pad or automatically using a direct station select (DSS) button that you have previously programmed. There are two methods for making an intercom call. One causes the called telephone to ring. The other causes your voice to sound out at the called telephone. Your installer can set the system to deliver either tone-first or voice-first calling.

Keep in mind that whatever the system setting, a called party can set a voice announce block condition at his or her telephone to prevent all voice announce calls. Furthermore, if he or she blocks voice announce, the system also blocks SOHVA calls.

*(The following instructions assume a tone-first setting. Any user can change a call to voice announce signaling for that call simply by pressing the INTERCOM button again after dialing the extension number or by pressing the DSS button again.)*

- To manually cause the other telephone to ring (tone calling),
  1. Press **INTERCOM**.
  2. Dial extension number (called telephone will ring).
- To tone call automatically,
  1. Press **DSS** button (called telephone will ring).

*(The following instructions assume a voice-first default setting. Any user can change a call to a tone signaling for that call simply by pressing the INTERCOM button again after dialing the extension number or by pressing the DSS button again.)*

- To voice announce manually,
  1. Press **INTERCOM**.
  2. Dial extension number.
  3. Speak your announcement.
- To voice announce automatically,
  1. Press **DSS** button.
  2. Speak your announcement.



### **3.8    *Camping On At A Busy Station And Waiting For An Automatic Callback***

---

If you call another station and receive a busy signal or a Do Not Disturb tone, you can press a button that will cause the system to ring your telephone when the station is available. This is called “camping on at a station.” Please note that you can camp on to only one station at a time.

- To camp on at any busy station,
  1. Press **CAMP ON**.
  2. Your telephone immediately hangs up. When the station you called becomes available, your telephone will ring with five short tone bursts.
- When you hear five short tone bursts,
  1. Press **INTERCOM**. The other telephone will start ringing.
  2. If you do not press **INTERCOM** after the ring back tones within the time limit set by the installer, the call back is canceled at that time; however, you can cancel automatic call back at any time before your telephone sounds the tone bursts.
- To cancel the call back before your telephone sounds the tone bursts,
  1. Press **INTERCOM** and dial # **6**.
- To camp on at a station with a Do Not Disturb condition set,
  1. Press **CAMP ON**. A call back will occur when called station is no longer set in the Do Not Disturb mode.

### **3.9 *Camping On At An Idle Station And Waiting For An Automatic Callback***

---

If you call another station and hear ringing but receive no answer, you can press a button that will cause the system to ring your telephone when any activity is initiated at that station.

- To camp on at a station for which you hear ringing but receive no answer,
  1. Press **CALLBACK** button. Callback will occur after any activity is initiated at dialed station. You may cancel the camp-on condition at any time by pressing **INTERCOM** and dialing # **6**.

**NOTE:** *This feature is not applicable to calls you make in the voice announce mode.*

### **3.10 *Camping On At A Busy Station And Waiting For An Answer (Call Waiting)***

---

If the telephone you have called is busy, you can send a call-waiting tone to the telephone and wait on the line for an answer (you must be using the handset for this feature to work).

- To activate call waiting when you hear a busy signal,
  1. Dial \* **6** (called party hears tone).
  2. Wait on line for reply.
  3. Called party can place the current call on hold or disconnect from the call to answer your call-waiting tone, or choose to ignore your call-waiting tone and continue current conversation.
- To cancel call waiting,
  1. Press **INTERCOM**, then dial # **6**.
  2. Hang up or press **SPEAKER** to end.

- To answer a call-waiting tone if you receive one while on a call,
  1. Hear short tone burst in receiver.
  2. Either place current call on hold or complete call and hang up (waiting call will ring at your telephone).
  3. Lift handset to answer call.

You may, of course, choose to ignore the call-waiting tone and remain on the line with your original caller.

### ***3.11 Overriding A Call Or A Do Not Disturb Condition At Another Telephone (Executive Override)***

---

You can override a call in progress or a Do Not Disturb condition at another telephone if the system installer has enabled the executive override feature at your telephone. (If the feature is not enabled through programming, an error tone will sound and screen options will remain displayed.)

- To override an in-progress call at another telephone,
  1. Make intercom call and hear a busy signal.
  2. Dial \* **03** (all parties will hear several tone bursts).
  3. Join in-progress call.
  
- To override a Do Not Disturb condition at another station,
  1. Press **OVERRIDE** to disable the Do Not Disturb condition at the called station.
  2. Speak your announcement (if in voice-first mode) or hear ring-back tone (if in tone-first mode).

***NOTE: This action disables DND condition at the other telephone until DND is reset.***

### **3.12 Making A Subdued Off-Hook Voice Announcement (SOHVA)**

You can make a subdued voice announcement to another station that is off-hook and busy on a call if the system is arranged to provide this feature. You decide whether to deliver a SOHVA message, camp on at that station, set a message-waiting indicator, or hang up when you hear an intercom busy tone.

- Make a SOHVA announcement using the **SOHVA** button as follows:
  1. Make intercom call and hear busy tone. If called station is on outside line, ring-back tone is heard, but SOHVA is still available.
  2. Decide whether to interrupt.
  3. If you decide not to interrupt the called party, hang up,  
—OR—  
to interrupt, press **SOHVA** and hear several quick tone bursts.
  4. Make announcement (busy tone means that the called telephone is in speakerphone mode and you cannot make announcement, that your SOHVA has been denied through system programming, or that the called party has blocked your SOHVA).
  5. Wait on line for reply (either verbal or LCD reply).

***NOTE: You cannot control how the announcement is received. This depends upon whether or not the called party is using a headset and how his or her station is programmed. For example, if the called party has set their station to call forward to voice mail or to another station not in the SOHVA group, your announcement will not be received.***

**4****Placing Calls On Hold****4.1 Holding Calls**

You can place a call on hold and retrieve it later. With a regular hold, you can pick up the held call at your telephone or another user can pick the call up at a telephone sharing the held call line. With an exclusive hold condition, you or another user must pick up the held call at your telephone; no other telephone has access to it. You can answer and place on hold a call that is on a line that does not appear at your telephone (a call that is parked or transferred to you, for instance).

After a call has been on hold for the period of time (set by the system installer), the system will cause four quick tone bursts to sound at your telephone, and speed up the flash rate of the line button light. If the call is on exclusive hold, it will revert to manual hold recall after a time-out period.

When you answer a call on a group intercom and place it on hold, the system keeps the call on hold on the group intercom. This means that you or any other user can pick up this call at any station that has access to the group intercom.

The installer can add a directed station hold feature to your telephone. With this feature, you can pick up the held call that has been on hold the longest length of time at another telephone. This feature also allows you to place a call on hold at another telephone in a manner that makes that call appear to have been on hold there for a longer period of time than any other held call.

- To place a call on hold,
  1. Press **HOLD**.
  
- To retrieve a held call,
  1. Press line button of the held call (with flashing light),  
—OR—  
press **TAP**.

***NOTE: Unless you use your HOLD button to scroll through the calls on hold, TAP always retrieves the last number placed on hold, regardless of whether you have line appearance for the line on which the call is holding.***

- To place a call on exclusive hold,
  1. Press **HOLD** twice.
  
- To retrieve exclusive hold,
  1. Press line button of held call (with flashing light),  
—OR—  
press **TAP** (if station does not have line appearance).
  
- To place a call on directed station hold,
  1. Answer call.
  2. Press **INTERCOM**.
  3. Dial **\*90**.
  4. Dial extension number of station to receive held call.
  5. Hang up.

- To retrieve a held call at another station,
  1. Press **INTERCOM**.
  2. Dial **#90**.
  3. Dial extension number of station holding the call.
  4. Answer call.

Often, you will have more than one call on hold at your station. If you have line appearance for the call placed on hold, you can retrieve it by pressing the appropriate line button.

However, even if you do not have line appearance for a call on hold, the system provides a way for you to access that call:

- To display a list of held calls and retrieve a specific one,
  1. Wait at least 5 seconds after placing the most recent call on hold and then press the **HOLD** button again.

Your telephone will display a list of up to eight held calls (identified by their line numbers or line names) that are on hold. The calls are displayed in the order they were placed on hold, with the most recent calls at the top of the list.
  2. Press the interactive button beside the call you want to retrieve.

## ***4.2 Handling Hold Recalls***

After a call has been on hold for the period of time (set by the installer of your system), the system will cause four quick hold recall tone bursts to sound at your telephone and the flash rate of the line button becomes faster.

If the call is on exclusive hold, it will revert to manual hold after the hold recall period (you will hear four short tone bursts at 12-second intervals). Calls that revert to manual hold can be picked up from any telephone with line appearance for the recalling line (or you can use the group or directed pick up buttons **GPKUP** or **DPKUP**).

- If a held line is recalling,
  1. Answer/retrieve recall.
  2. Press **HOLD** to place the call on hold at your station and restart HOLD timer,  
—OR—  
press **ANSWER** to retrieve the call.



### **4.3 Parking Calls**

You can place a call on hold in the system so that it can be answered from any station that does not have a line appearance for the call. You accomplish this by placing the call in one of 90 park orbits, where the call remains until it is answered. If the call is not answered within a specified period of time, the system will send it back to your station for service (this is known as a park recall).

When you press a personal or group intercom button and dial a code to retrieve a parked call, the system removes it from the park orbit and places it at your station on the intercom you selected.

You can preprogram a **PARK** button at your telephone (see section 9.5 *Using The Feature Buttons*) and use it to simplify your call parking efforts.

- To park a call in orbit,
  1. While on the call, press **INTERCOM**.
  2. Press \*,  
—OR—  
press **TRANSFER/CONFERENCE**, if intercom call.
  3. Dial code for park orbit (**910-999** for orbit 1-90).
  4. Remember the code for later use or make it known to those who need to know it in order to retrieve the call.
- To park a call using a preprogrammed **PARK** button,
  1. While on the call, press the preprogrammed **PARK** button (the system places the call in a preselected park orbit and lights the **PARK** light).
- To retrieve a call that was placed on hold in the system (parked),
  1. From any station, press **INTERCOM**.
  2. Press #.
  3. Dial code for orbit (**910-999** for orbit 1-90),  
—OR—  
press preprogrammed **PARK** button.

## **4.4 Handling Park Recalls**

When a parked call times out of the system, it will return to your telephone in the form of a park recall (you will hear four short tone bursts at 12-second intervals). Your LCD will indicate that the call is a park recall and will identify the orbit from which the recall originated.

- To answer a park recall,
  1. Press **ANSWER**. The call will then connect to your station.
- To place a park recall on hold at your station,
  1. Press **HOLD**. If the call remains on hold for a period of time, it will ring back to your telephone as a hold recall.
- To re-park a park recall and restart the park timer,
  1. Answer/retrieve call (this step is only necessary if you wish to talk to the person before re-parking the call).
  2. Press **PARK** (the call will then be placed back in its original park orbit and will remain there until it is answered or until it recalls again).

**5****Transferring Calls****5.1 Transferring Calls—Screened**

You can answer a call at your LCD speakerphone and transfer it to another telephone. If you first identify the caller to the party receiving the transfer (giving that user the opportunity to prepare for the call), you have made a *screened transfer*.

If the telephone to which you are transferring the call is busy, you must recover the call yourself or choose one of several options that may be available at your station. Also, if a transferred call is not answered after a certain length of time (as set by the installer), it recalls to your telephone. Again, you have several options for servicing the returning call.

- To screen and transfer a call to another telephone in the system,
  1. Answer call or make call.
  2. Press **TRANSFER/CONFERENCE** (call is automatically placed on hold).
  3. Dial extension number of telephone to receive transfer or press DSS button for that extension.
  4. When intercom party answers, announce call.
  5. Press **SPEAKER** to disconnect (if in speakerphone mode), or hang up.
  6. The intercom party then has the call (if he or she answered the screened transfer with the handset or confirmed answer by pressing their intercom button). If you announce the transfer over the speaker, the intercom party's telephone will ring with the transferred call after you hang up.

- If the intercom party is busy, take one of the following steps (if made available at your telephone by installer programming):
  1. Press **RECONNECT** to reconnect the call to your station.
  2. Press **SOHVA** to interrupt the call and tell the intercom party that a call awaits.
  3. Press **MESSAGE** to leave a message-waiting indication at the called station.
  4. Press **CALLBACK** to camp-on at the called station.
  
- If the intercom party does not answer their telephone when ringing, take one of the following steps:
  1. Press **RECONNECT** to reconnect the call to your station.
  2. Press **MESSAGE** to leave a message-waiting indication at the station.
  3. Press **CALLBACK** to camp-on at the called station.

## **5.2 Transferring Calls—Unscreened**

You can answer a call at your LCD speakerphone and transfer it to another telephone. If you transfer the call without first announcing it, you have made an unscreened transfer.

If the telephone to which you are transferring the call is busy, you must recover the call yourself or choose one of several options that may be available at your station. Also, if a transferred call is not answered after a certain length of time (as set by the installer), it recalls to your telephone. Again, you have several options for servicing the returning call.

- To transfer an unscreened call to another system telephone,
  1. Answer call.
  2. Press **TRANSFER/CONFERENCE** (call is automatically placed on hold).
  3. Dial extension number of telephone to receive transfer or press DSS button for that extension.
  4. Press **SPEAKER** to disconnect (if in speakerphone mode), or hang up. The transfer will ring at the called telephone.

***NOTE: Unscreened transfers ring at busy telephones and wait to be answered.***

- If an unscreened transfer call is not answered and recalls to your telephone, you can take one of the following steps:
  1. Press **HOLD** to place the call on hold at your telephone.
  2. Press **ANSWER** to return to the call.
  3. Press **SEND** to retry the transfer.

### **5.3 Making A Hot Transfer**

A hot transfer is a type of screened transfer. To perform a hot transfer, you voice announce the transfer over the speaker of the telephone that you want to receive the transfer, and release the call to that telephone. The system handles the release in a way that does not require the called party to retrieve the call (the call does not ring at the station).

This feature is useful for transferring calls to people who need to work in a handsfree mode. Once you announce the call and the system completes the transfer, the person receiving the transfer can simply begin speaking toward his or her speakerphone to answer the call.

If you make a hot transfer to a monitor telephone, you can voice announce the call over the telephone's speaker, but the person receiving the outside line transfer will need to lift the handset to answer the call (the telephone will not ring after the announcement is made).

Please note that you cannot make a hot transfer to a telephone if its user has enabled the Voice Announce Block feature. This telephone will automatically ring with the transfer requiring the intercom party to answer it as either a screened or an unscreened transfer.

- To make a hot transfer to another telephone in the system,
  1. Answer call.
  2. Press **TRANSFER/CONFERENCE** (the call is automatically placed on hold).
  3. Dial extension number of telephone to receive the transfer or press the DSS button for that extension.
  4. Announce call.
  5. Press **TRANSFER/CONFERENCE**.
  6. Press **SPEAKER** to disconnect (if in speakerphone mode) or hang up. The person receiving the transfer then has the call.

## **5.4 Transferring Calls Using Quick Transfer**

When the quick transfer method has been programmed by the installer, it allows you to do an automatic screened or unscreened transfer of an incoming line call without pressing the **TRANSFER/CONFERENCE** button. The transfer occurs automatically whenever you answer a call and then dial the intercom number for the transfer location.

- To do a quick screened transfer,
  1. Answer call.
  2. Dial intercom number for transfer location.
  3. When party at transfer location answers, announce call.
  4. Hang up, press **RELEASE**, or press **SPEAKER** button.
- To do a quick unscreened transfer,
  1. Answer call.
  2. Dial intercom number for transfer location.
  3. Hang up, press **RELEASE**, or press **SPEAKER** button.

*This page remains blank intentionally.*



6

## Conferencing Calls

### 6.1 Conferencing Telephones Together

When you join your LCD speakerphone together with several other telephones on the same call, the result is called conferencing. When using the DXP system, you can make conference calls that involve up to five parties, including you as the originating party, in any combination of outside lines and intercom parties. For example, you can conference three outside lines and two intercom parties, or four outside lines and one intercom party, or five intercom parties—the combinations are up to you. When using the DXP *Plus* or FX Series system, you can include up to seven parties (in various combinations) in a conference call.

If you are involved in a conference call with two outside lines, you can drop out of this established conference call and leave the outside lines in the conference with each other. This is known as an unsupervised conference call.

- To set up a conference call that includes any combination of outside lines and intercom parties,
  1. Make first call.
  2. Press **CONFERENCE**; call is placed on hold automatically.
  3. Select next line and make next call.
  4. Press **CONFERENCE** to establish conference.
  5. Press **TRANSFER/CONFERENCE** button to add more parties.
  
- To continue conversation on remaining line after other outside lines have dropped out of conference,
  1. Press **HOLD**.
  2. Press the line button of the remaining party.

- To retrieve a line from hold and bring that party back into the conference,
  1. Press **TRANSFER/CONFERENCE**.
  2. Press line button.
  3. Press **TRANSFER/CONFERENCE**.

***NOTE: If all the conference circuits are busy, you will not be able to add a party to the conference.***

- To drop out of a conference call you initiated involving outside lines (creating an unsupervised conference),
  1. Dial # (lines remain lighted and in use until one or both outside parties disconnect; when only one party drops out of an unsupervised conference, the other party remains on hold until he hangs up or the line is answered).
- To rejoin an unsupervised conference between two outside lines,
  1. Press **TAP**.

***NOTE: Conference volume levels depend upon the quality of the external lines.***

- To drop a party out of a conference call,
  1. Press **DROP PARTY**.
  2. Select the party you wish to drop from the conference call by pressing the interactive button beside the appropriate line.

# 7

## Using The Other Telephone Features

### 7.1 Adjusting The Display Contrast

You can adjust the contrast of the display to darken or lighten it for best viewing.

- To adjust the display contrast,
  1. Press **OPTIONS**.
  2. Press **PROGRAMMING**.
  3. Press the **CONTRAST LEVEL** button (to the right of the LCD, on the same row as the words “Contrast Level”) once for each change of darkness you desire. Each press of the button makes the display darker until you go past level eight and return to level one.
  4. Press **EXIT** to end.

### 7.2 Blocking Voice-Announce Calls

You can prevent voice announcements from sounding over your telephone speaker if you wish. This feature also blocks subdued off-hook voice announcements.

- To block voice-announced calls,
  1. Press **OPTIONS**, then press **PROGRAMMING**.
  2. Set voice announce block to ON by pressing the **VOICE ANNOUNCE BLOCK** button (located right of the LCD).
  3. Press **EXIT** to end.

- To un-block voice-announced calls,
  1. Press **OPTIONS**, then press **PROGRAMMING**.
  2. Set voice announce block to OFF by pressing the **VOICE ANNOUNCE BLOCK** button (located right of the LCD).
  3. Press **EXIT** to end.

### ***7.3 Displaying Status Of Busy Lines and Stations (Busy Button Inquiry)***

---

You can use this installer-provided feature to identify the station that is busy on a line or the line on which a station is busy. The system presents the station or line information on your display for 10 seconds after you request it. If your station does not have this feature, the system presents busy information on the display without identifying the line or the station.

- To identify the station that occupies a busy line,
  1. Press button for busy line.
  2. Read your display for intercom number of station that is busy on line.
- To identify the line that a busy station occupies,
  1. Press DSS button for busy station.
  2. Read your display for the busy station's line number.

## **7.4 *Displaying Button Functions (Button Query)***

---

You can cause the display to identify the function of each button on your telephone. This is useful when the installer has assigned your programmable buttons for special-purpose tasks and you need to remind yourself of the button's feature.

- To button query your telephone,
  1. Press **OPTIONS**, then press **PROGRAMMING**.
  2. Press **NEXT** until the **BUTTON QUERY** option appears.
  3. Press **BUTTON QUERY**.
  4. Press the button in question.
  5. Read the displayed information (display will hold for few seconds before the telephone returns to idle).

## **7.5 *Diverting Incoming Calls To Another Station***

---

Call diverting permits you to send an incoming call to another station that you have previously designated. You can divert an incoming call to the designated station whether you are busy or idle.

- To identify the station to receive diverted calls,
  1. Press **INTERCOM**.
  2. Dial \*55.
  3. Dial extension number of station to receive diverted call.
- To divert calls to the designated station,
  1. Hear ringing and/or see flashing line status light.
  2. Press **DIVERT** (system immediately forwards ringing call to station you designated).

## **7.6 Entering Account Codes**

If the installer has arranged your system for account code entry\*, your display may prompt you to enter an account code before dialing or after answering a call. Depending on how the installer programmed your system, these account codes may be “forced”(mandatory) for dialing outside numbers.

\*System must be activated through installer programming to accept account codes.

***NOTE: You can program a button on your telephone that will make the account code entry process quicker. Refer to the programming section of this user’s guide for details.***

- To enter account code on an incoming call,
  1. Press **ACCOUNT CODE**.  
—OR—  
Press preprogrammed **ACCOUNT CODE** button.  
—OR—  
Press **INTERCOM**, then dial **\*04** (call is automatically placed on hold but will return from hold after you’ve dialed the account code).
  2. Dial account code.
  
- To enter account code on an outgoing call,
  1. Press line button (LCD will prompt for “Account Code” if programmed to do so).
  2. Press **ACCOUNT CODE**.
  3. Dial account code.
  4. Listen for dial tone and dial number you are calling.

***NOTE: If you hear an error tone after you have dialed your account code, check the number for validity.***

## 7.7 Entering Authorization Codes

Authorization codes give you a *walking class of service* option. *Walking class of service* provides you with the mobility to use your class of service (COS) features, prime line assignments, and exception numbers on any telephone in the system. This means that you will not be limited by features that are available to the particular telephone that you happen to be using. Authorization codes are associated with your personal intercom number and are assigned to you by your installer when he or she programs the system. When you enter your assigned authorization code at any system telephone, the code alerts the system to make your normal features available to you. This means that you can use the telephone for anything allowed by your personal intercom number; however, you cannot disturb the last number redial stored there by the normal user. Once you access your telephone features, they remain in effect until any idle time exceeds the authorization code time-out period.

If your telephone includes an installer-programmed **LOCK** button, you can press it and then dial your authorization code to deny other users access to lines and features at your LCD speakerphone.

- To activate walking class of service,
  1. Select system telephone to use.
  2. Press **INTERCOM**.
  3. Dial **#08**.
  4. Dial your authorization code.
- To lock your telephone,
  1. Press **LOCK**.
  2. Dial your authorization code.

***NOTE: If you wait longer than two seconds to dial a digit after you press the LOCK button, that pause, and any others that you might include, becomes part of the lock code. However, before you can enter a pause, you must begin the code with a digit. The telephone display will show a (-) to represent a pause as part of the code as you enter it. You must allow for any pauses at any location that you inserted them in the number string when you unlock your telephone. This feature provides you with a method for creating a very effective lock and unlock password.***

- To unlock your telephone,
  1. Press **LOCK**.
  2. Dial your authorization code (remember, include any pauses that you inserted when you locked your telephone).

***NOTE: When a telephone is locked, it is totally disabled. Not even 911 calls will go through.***

## **7.8 Forwarding Calls**

You can permanently forward the calls that normally ring at your telephone to another telephone. You can forward just your prime line and intercom calls, or you can forward all of your calls. To remind you that your calls are being forwarded, your telephone will sound a short ring burst each time the system forwards a call.

You can also forward calls that ring at your telephone but receive no answer; this feature is valuable if you are frequently away from your desk for short periods of time and find it inconvenient to permanently forward your calls every time you leave. The system installer sets the number of rings that sound at your telephone before the system forwards the calls.

- To forward your calls,
  1. Press **OPTIONS**, then press **PROGRAMMING**.
  2. Press **NEXT** until the **CALL FORWARD** option appears.
  3. Press **CALL FORWARD**.
  4. Select the type of calls you would like to forward, and press the corresponding button on the left side of the LCD.
  6. Dial extension number or press DSS button of telephone to receive your forwarded calls.
  7. Press **EXIT** to end.
- To cancel call forwarding,
  1. To cancel call forwarding, select the **CANCEL** option offered in your LCD when call forwarding is enabled.



## **7.9    *Listening To A Call Over The Telephone Speaker (Group Listening)***

---

You can turn on the speaker in your LCD speakerphone while you have the handset lifted if you wish. The distant party's voice then sounds over the speaker as well as over the handset; however, only your handset microphone is active.

This group listening feature also works if you are using your headset (only the headset microphone will be active).

- To activate group listening while on a call,
  1. Press the **MORE** button, then press the **GROUP LISTEN** button.

**NOTE: To activate the group listening feature, press SPEAKER for two seconds.**

- To cancel group listening,
  1. Press the **GROUP LISTEN** button again.

**NOTE: You should cancel Group Listening before hanging up the handset to end the call.**

## ***7.10 Making A Call Non-Private (Privacy Release)***

---

It is often the case that telephones will share line appearance for one or more lines. When a person in the group uses a line for which others have the same line appearance, the system keeps the call private (others cannot join the conversation by pressing the line button of the line being used).

That person can make the call non-private by pressing the preprogrammed **PRIVACY RELEASE** button, allowing other telephones (with line appearance for the line being used) to join the call. Privacy returns to the line when the call is completed.

Refer to the chapter on programming for instructions on how to program the **PRIVACY RELEASE** button.

- To release privacy from your telephone while on a call,
  1. Press preprogrammed **PRIVACY RELEASE** button. (The light associated with the **PRIVACY RELEASE** button will remain on steady when your telephone is in a non-private mode.)

If another party wishes to join the call, they must press the active line button on their telephone.

### **7.11 Monitoring A Conversation Between Two Telephones (Service Observing)**

---

If your LCD speakerphone provides the installer-programmed *service observing* feature, you can use it to monitor a conversation or activity at another telephone in an undetected manner. You can use this feature while you are in the speakerphone mode or off-hook.

- To monitor another station at any time,
  1. Press **INTERCOM**.
  2. Dial # **0 3**.
  3. Dial extension or press DSS of station you wish to observe.
  4. Press **SPEAKER** to end monitoring.
  
- If you have an installer-programmed **SERVICE OBSERVE** button on your telephone and wish to monitor a station,
  1. Press **SERVICE OBSERVE** button.
  2. Dial extension or press DSS of station you wish to observe.
  3. Press **SPEAKER** to end monitoring.

## **7.12 Muting Your Telephone**

By using the **MUTE** button, you can block transmission of your voice to the distant party. You can do this whether you are using the handset or the speaker. For example, if someone comes into your office to talk to you and you do not want this conversation to interrupt the distant party, press the **MUTE** button. The **MUTE** button light turns on when you press it and turns off when you press it again.

- To mute your telephone,
  1. Press **MUTE** (MUTE function and light turn on). You can still hear the distant party, but he or she cannot hear you.
- To speak to the distant party,
  1. Press **MUTE** again (MUTE function and light turn off).

## **7.13 Sending A Paging Announcement**

Your system provides an all-call or a zone page feature that you access by dialing special codes. This arrangement sounds your voice announcement through the telephone speakers. All-call sounds the announcement through all telephones, while zone paging sounds the announcement only through those telephones located in a specific area. Check with your system administrator to determine the type of paging and access method you should use. If your day-to-day operation requires that you send many paging announcements, you can program a special all-call/zone paging button to give quick access to the feature. See the programming section of this user's guide for details.

Your installer can arrange your system with an external paging unit that you access by pressing a line button or by dialing a special code. This unit sounds the voice announcement over an external speaker unit. Check with your system administrator for specific information on how to operate with such an arrangement.

- To send a paging announcement,
  1. Lift handset.
  2. Press **INTERCOM**, then dial **70-77** for zones 1-8 (in the default mode, zone 1 (code 70) provides an all-call function),  
—OR—  
press a preprogrammed **PAGE** button.
  3. Make announcement.
  4. Remain on line if awaiting a reply (known as a meet-me page),  
—OR—  
hang up handset.

At times other telephone users may page you with instructions to meet them on line. This is known as a meet-me page. You can go to the nearest telephone, dial a code, and be in contact with the paging party.

- To reply to a meet-me page,
  1. Lift handset of nearest telephone.
  2. Press **INTERCOM**.
  3. Dial **78**.
  4. Meet paging party on line.

## 7.14 ***Setting A Do Not Disturb Condition At Your Station***

---

This feature keeps calls from ringing at your LCD speakerphone and makes your station appear to be busy to intercom calls. If your installer has programmed your station to have this feature, you can enable it as needed.

Generally, callers cannot override this feature. They hear two quick tone bursts every two seconds when they call a telephone that is set to the do not disturb mode. However, the installer may program some telephones with the ability to override a do not disturb condition at another telephone.

You can program a permanent do not disturb button to provide yourself with quick access to this feature if you wish. See the programming section of this user's guide for details.

- To enable or disable the Do Not Disturb, proceed as follows:
  1. Press ***OPTIONS***, then press ***PROGRAMMING***.
  2. Press the ***DO NOT DISTURB*** (to the right of the LCD) to toggle the Do Not Disturb feature on or off.
  3. Press ***EXIT***.
- To set a do not disturb condition at your telephone when a call rings at your station,
  1. Hear ringing and notice incoming call information in display.
  2. Select ***DO NOT DISTURB*** option. Ringing will stop, caller will hear the do not disturb tone, and your telephone will remain in DND until you disable the feature (described above).
- To override a do not disturb condition at another telephone, use the procedure detailed in section 3.10.

## **7.15 Setting The Volume Control**

The volume control on your telephone is a multipurpose control you can use to set the volume (loudness) of the ringer, the speaker, the handset, the headset, background music, and the group listening mode. You can either press and hold down the **VOLUME UP** or **VOLUME DOWN** button to automatically step through the volume levels for each mode, or you can press the switch once for each change in volume you desire.

You may adjust the loudness of the distant party at any time during a call whether you are listening over the speaker, the headset, the handset or the group listen mode by pressing the **VOLUME UP** or **VOLUME DOWN** button. When the call ends, the system resets the loudness of all future calls to the programmed (default) setting.

You can set a permanent loudness level for any volume control setting. When loudness is at desired level, press the **SAVE** button. The level will remain at this loudness (referred to as the default setting) until you change the setting.

***NOTE: The Impact SCS 8412S-\*\* and SCS 8412F-\*\* support the optional ICVOL-\*\* handset. The ICVOL-\*\* is an amplified handset with its own volume control, making it useful in noisy environments. For ordering information, contact your Comdial dealer.***

- There are four **ringer** loudness levels (plus an *off* position). Set these levels as follows:
  1. While your telephone is on-hook and idle, press the **VOLUME UP** or **VOLUME DOWN** button once for each change in loudness you desire. The ringer sounds once for each change as an example of the current setting.
  2. Press the **SAVE** button.

***NOTE: If you set the ringer to the “off” position, your telephone will sound a short ring burst once for each call you receive at your station while the ringer is off.***

- There are eight *speaker* loudness levels. Set these levels for the current call as follows:
  1. While on a call and in speakerphone mode, press the **VOLUME UP** or **VOLUME DOWN** button once for each change in loudness you desire.
  2. To make the current speaker setting the default setting, press **SAVE**.
  
- There are at least eight *handset* loudness levels you can set for the current call as follows:
  1. While on a call and in handset mode, press the **VOLUME UP** or **VOLUME DOWN** button once for each change in loudness you desire.
  2. To make the current handset setting the default setting, press **SAVE**.
  
- There are eight *headset* loudness levels that you can set for the current call as follows:
  1. While on a call and using the headset press the **VOLUME UP** or **VOLUME DOWN** button once for each change in loudness you desire.
  2. To make the current headset setting the default setting, press **SAVE**.
  
- There are eight *group listening* loudness levels. Set the level for the current call as follows:
  1. While on a call and in the group listening mode, press **VOLUME UP** or **VOLUME DOWN** button once for each change in loudness you desire.
  2. To make the current group listening setting the default setting, press **SAVE**.



- There are eight *background music* loudness levels. To set the level,
  1. While background music is on at your station, press **VOLUME UP** or **VOLUME DOWN** button once for each change in loudness you desire. This level will remain set for background music until you change it again, even if you turn off the feature and then reactivate it.
  2. To make the current background music setting the default setting, press **SAVE**.

## ***7.16 Setting Your Personal Ringing Tones***

---

You can choose one of eight different ring tones for your telephone. Often, when several telephones are located close together, each user chooses a different personal ring tone.

- To select one of the ring tones, proceed as follows:
  1. Press **OPTIONS**, then press **PROGRAMMING**.
  2. Press **NEXT** until the **RING TONE** option appears.
  3. Press the **RING TONE** button (to the right of the LCD) to scroll through the ring tones.
  4. When you have found a ring tone you like, press **EXIT** to return to main display.
  5. The next time your telephone rings, you will hear the new ring tone.

### ***7.17 Switching The Dialing Mode Between Pulse And Tone***

---

If the telephone service in your locality is pulse (rotary dialing), the installer arranges your telephone to dial in this manner. If you need to send tones during a dialing sequence (for example, to send bank-by-telephone tones), you can convert to tone dialing mode while dialing. The system will switch back to pulse dialing when you end your call.

You can store a # as part of a speed dial number to cause an automatic switch from pulse to tone where needed in a number sequence.

- To convert to tone dialing at any time during dialing or while on an active call,
  1. Press #.

### ***7.18 Using Background Music***

---

If the telephone system supplies background music, you can turn it on at your LCD speakerphone while it is on-hook and idle. The system automatically turns background music off during calls and voice announcements.

- To turn the music on or off,
  1. Press **OPTIONS** then press **PROGRAMMING**.
  2. Press **NEXT** until the **BACKGROUND MUSIC** option appears.
  3. Press the **BACKGROUND MUSIC** button (to the right of the LCD) to select music source 1, music source 2, or OFF.
  4. Press **EXIT**.
  5. If you have turned music on, adjust music volume with the volume buttons.

## **7.19 Using Direct Inward System Access (DISA)**

---

This feature allows you to call into the digital communications system from an external telephone. You can call directly to intercom extensions and talk to the intercom parties or, if the system includes a voice mail option, leave messages for them if they are not available. When you call the DISA telephone number and dial your authorization code, the system treats your call as it would treat one coming from a system telephone and permits you to use many of the same features that you can use when you are calling from your assigned station. (Authorization codes are associated with personal or group intercom numbers and are assigned to you by your installer when he or she programs the system.) If you use your DISA access to make a call through the system and out on an outside line, the system applies all the toll restriction and automatic route selection to the call that the installer has programmed for the line that you are using. If you dial an incorrect authorization code, or the system is busy with other DISA calls, you will either hear an error tone, or the system will automatically route your call to one of the following areas (as determined by your system installer):

- a designated station where you can talk to the system attendant,
- a digital voice announce that will prompt you to take additional action,
- a proprietary voice mail station where you will be prompted to leave a message.

The system allows you three tries at dialing your authorization code before it routes your call as detailed above.

Some systems provide voice prompts to DISA callers and other systems do not. If you encounter voice prompts when you call on the DISA line, follow the prompt directions to complete your call.

Further, some systems with voice prompt enhancement, provide a one-digit menu that prompts you to dial a single digit to reach available departments, use system features, or obtain operator assistance.

***NOTE: DISA is not recommended for use on loop start lines without disconnect supervision. While DISA will function, Comdial will not be liable for its performance under any condition where disconnect supervision is not provided.***

Comdial has taken reasonable steps in the design of all product features, including DISA, which protect against unauthorized or fraudulent access to, or use of, a system, or which protect against unauthorized, fraudulent or unaccounted-for access to, or use of, long distance lines. However, no system is entirely invulnerable or immune from unauthorized or

fraudulent access or use, or unaccounted-for access or use, and therefore Comdial disclaims any and all liability, and makes no warranty, express or implied, relating to unauthorized or fraudulent access or use, or unaccounted-for access or use.

- To make a DISA call to an intercom number,
  1. Dial number for DISA line (listen for voice prompt if available).
  2. Dial extension number.
  3. If station does not answer or is busy you will either hear busy tone or hear voice prompt if available. If you dial an invalid number, you will hear error tone.
  4. If voice prompt provides dialing codes, dial proper code for services such as: track, message waiting, or voice mail.
  
- To make a DISA call to use system features,
  1. Dial number for DISA line (listen for voice prompt if available),
  2. Dial authorization code (listen for voice prompt if available; otherwise, hear stutter-style dial tone—remember, the system gives you only three tries to dial your code correctly),
  3. Dial feature code and listen for acknowledgment tone.

***NOTE: If you are selecting a line group through DISA for outside calling, you can raise the audio level on this line when needed. Do this before you select the line by dialing \*\*7, and then dialing 1 for 0 dB, 2 for +3dB, or 3 for +6dB of gain. In some cases, added gain can introduce circuit instability that presents itself as a singing sound, which can interfere with dialing and voice communications. If you experience this condition, select a lower gain setting.***

System Features Available To DISA Callers	Default Dialing Code
<b>Account code entry</b>	<b>*04</b>
<b>Automatic route selection access</b>	<b>9</b>
<b>Call waiting on busy</b>	<b>*6</b>
<b>Do not disturb override</b>	<b>*03</b>
<b>Intercom dialing/call announcing</b>	<b>nnnn</b>
<b>Message wait off*</b>	<b>#3</b>
<b>Message waiting set*</b>	<b>*3</b>
<b>Personal speed dial*</b>	<b>*01</b>
<b>System speed dial</b>	<b>*01*</b>
<b>Tracker access**</b>	<b>*8</b>
<b>Tracker page orbit retrieval**</b>	<b>#8</b>
<b>Trunk group access</b>	<b>9, 80-89, 60-64</b>
<b>Zone paging</b>	<b>70-77</b>
* You must have an assigned personal intercom number to use this feature.	
** Your system must provide the Tracker option to activate this feature.	

---

## ***7.20 Using The Tracker Paging System***

The Tracker Paging System option allows you to send call back and parked call messages to Tracker pagers assigned to station extension numbers.

Along with the parked call message, the system parks the call in orbit for retrieval by the paged party. The type of message that the system delivers (either alphanumeric or numeric-only) is dependent upon the Tracker pager model in use at the station.

When outside callers call into a system that has both a Tracker Paging option and a voice mail option installed, the system gives these callers the option of either leaving a message or tracking the person that they are calling.

If you have a Tracker pager assigned to your personal intercom number, you can receive messages that someone else sends you. The system automatically installs the Tracker pager for your use; however, you can disable it when you do not wish to receive paged messages and when you leave at the end of your day. Of course, if you do disable your Tracker pager at the end of your day, be sure to enable it at the beginning of your next day.

Your LCD speakerphone includes an interactive **TRACK** button; however, if your day-to-day operation includes extensive Tracker usage, such as in an attendant function, your installer may include a **TRACK** button at a programmable button location.

- To track a called party after receiving a ring—no answer,
  1. Make an intercom call to someone and receive no answer.
  2. Press **TRACK**.
  3. Hear confirmation beep (Tracker page accepted) or hear busy tone (Tracker page not accepted).

- To track a called party without first calling them,
  1. Press **INTERCOM** and dial \*8.
  2. Dial extension number.  
—OR—  
Press the **LIST NAMES** button (to the left of the LCD). The display shows several letters beside each interactive button. Press the button next to the letter of the person's name whom you wish to call. The display shows the first existing name match to the letters you selected or shows a **No Name Match** message if the system cannot find a match.  
  
***NOTE: All the names starting with the letters you selected will appear, but they will not be in alphabetical order.***
  3. Press **NEXT** to display the subsequent names in the index until you reach the name you need.
  4. Hear confirmation beep (Tracker page accepted) or hear busy tone (Tracker page not accepted).
  
- To use Tracker to transfer a call to a park orbit for retrieval and transmit the call's park orbit code and caller ID information (if available),
  1. Answer call and press **TRANSFER**.
  2. Dial extension number.
  3. If the called station does not answer or is busy, press **TRACK**.
  4. Hear confirmation beep (Tracker page accepted) or hear busy tone (Tracker page not accepted).

***NOTE: Tracker parked calls will recall to your station after a preprogrammed time-out. You can either place the call into another Tracker page orbit or retrieve the call.***

- To retrieve a call that you parked using the Tracker option,
  1. Press **HOLD** button to scroll your held calls, (display shows *Page* and extension number of each parked call).
  2. Press **TAP** to retrieve the displayed parked call.
  
- If you receive a parked call message on your Tracker pager,
  1. Go to any system station.
  2. Press **INTERCOM**.
  3. Dial Tracker pager displayed orbit code (**#800-#899**).
  4. Retrieve call.
  
- To enable or disable a Tracker pager at your station,
  1. Press **INTERCOM**.
  1. Dial **\*06** to disable,  
—OR—  
dial **\*07** to enable.
  2. Press **SPEAKER** to end.



## 7.21 Using E and M Tie Lines

E & M tie line operation is typically used in applications where one group of users often need to call parties located in one or more remote locations. In these applications, your system is directly tied to another similar system at the remote site(s).

If your system has been configured for tie line operation, the procedures you use to place calls, transfer calls, and set up conference calls differ slightly from other types of connections. These procedures are described in this section.

- To make a call on an E & M tie line,
  1. Dial the E & M access code that was assigned by the installer,  
—OR—  
if your system has been configured by the installer to use Automatic Route Selection (ARS), dial the ARS access code (9).
  2. Wait until you hear a dial tone, then dial the intercom number for the party you wish to reach at the remote site. You will hear a fast busy signal if you dialed an invalid number.
  
- To transfer a call over an E & M tie line,
  1. Answer the incoming call.
  2. Press **CONFERENCE**.
  3. Dial the E & M access code assigned by the installer,  
—OR—  
if your system was configured by the installer to use Automatic Route Selection (ARS), dial the ARS access code (9).
  4. Wait until you hear a dial tone, then dial the intercom number for the distant party to whom you are transferring the call.
  5. If you are doing a screened transfer, stay on the line until the called party answers so that you can announce the call,  
—OR—  
hang up (unscreened transfer). If the called party does not answer, the call will return to you after the transfer recall timer expires.

**NOTE:** *After transferring the call to the remote end of the E & M tie line, you will have created an unattended conference, and your telephone will appear as though it were on hold.*

6. Press **TAP** button to rejoin the transferred call.
7. After rejoining the conference, press **#** to place the call on hold again (creating another unattended conference) or hang up to terminate the call.

*\* You can eliminate this step if the installer has configured your system for quick transfer and you are accessing the E & M line with a group access code.*

If one of the parties does not hang up or you have not terminated the call, the call will return to you when the line-to-line connection timer expires.

- To set up a conference call on an E & M tie line,
  1. Make first call.
  2. Press **CONFERENCE**; call is placed on hold automatically.
  3. Select next line and make next call.
  4. Press **CONFERENCE** to establish conference.
  5. Press **TRANSFER/CONFERENCE** button to add more parties for up to a 7-party conference (including yourself).
- To continue conversation on remaining line after other outside lines have dropped out of conference,
  1. Press the line button of the remaining party.
- To retrieve a line from hold and bring that party back into the conference,
  1. Press **TRANSFER/CONFERENCE**.
  2. Press line button.
  3. Press **TRANSFER/CONFERENCE**.

**NOTE:** *If all the conference circuits are busy, you will not be able to add a party to the conference.*

- To drop out of a conference call between you and two outside lines (creating an unsupervised conference),
  1. Hand up (lines remain lighted and in use until one or both outside parties disconnect).
- To rejoin an unsupervised conference between two outside lines,
  1. Press **TAP**.

**NOTE:** *Conference volume levels depend on the quality of the external lines.*

## **7.22 Call Forward Outside System**

The Call Forward Outside System (CFOS) feature allows you to forward incoming or transferred line calls to telephone numbers outside the system. The CFOS feature forwards calls over any available outbound line or line groups and does not use any conference circuits. Since CFOS involves outbound calls, those calls are subject to all line access, toll restriction, and automatic route selection restrictions normally imposed on your calls. The CFOS feature is useful if you need to forward your after-hours calls to an alternate site such as your home or cellular telephone.

- To activate CFOS with your LCD speakerphone,
  1. Press **OPTIONS, PROGRAMMING, NEXT, CALL FORWARDING**.
  2. Press **CFOS**.
  3. Select the type of call(s) you want to forward by pressing the top, right-hand interactive button to scroll through the list of call types.
  4. Select forwarding destination (dial number, press speed dial button, or do nothing and let previously selected destination remain in effect).
  5. Press **EXIT** to end (display shows CFOS).

- To deactivate CFOS,
  1. Press **CFOS** interactive button.  
—OR—  
Press **CFOS** preprogrammed button.  
—OR—  
Press **INTERCOM** and dial # **5**.
  
- To join an active CFOS call from the CFOS-enabled station,
  1. Note flashing **HOLD** light indicating active CFOS call, and press **TAP**. Join CFOS-forwarded party and CFOS destination in a conference call.

Comdial has taken reasonable steps in the design of all product features, including CFOS, which protect against unauthorized or fraudulent access to, or use of, a system, or which protect against unauthorized, fraudulent or unaccounted-for access to, or use of, long distance lines. However, no system is entirely invulnerable or immune from unauthorized or fraudulent access or use, or unaccounted-for access or use, and therefore Comdial disclaims any and all liability, and makes no warranty, express or implied, relating to unauthorized or fraudulent access or use, or unaccounted-for access or use.

## **7.23 Mark Problem Line**

Your programmer can arrange the system so that you can mark a line that is not functioning properly. You do this by pressing a preprogrammed **MARK** button or by dialing a feature code of your choice. After you have marked a particular line a programmed number of times, the system takes the line out of service (unless programmed to prevent this from happening). When the system takes the line out of service, it logs the condition and triggers an alarm. The printed error log will then show which line is out of service and so will the displayed error log. An out of service line is only out of service for line group use; it is available for direct selection or prime line access. Further, an out of service line is available for all inbound calls unless it is a DID line. You cannot mark a line during a conference call or if you are calling in as a DISA caller.

The system manager can use the line disable feature at the programmer's station to restore service on the out of service line.

- To mark a line,
  1. Press the **MARK** button on your telephone,  
—OR—  
press **INTERCOM** and dial a code of your choice.  
(The system will not accept your choice if it conflicts with an existing feature code or intercom number.)

***NOTE: When you mark a line during an active call, the system records the mark for the active line. If you take marking action during an idle condition, the system records the mark for the last active line (this includes lines that are presently on hold).***

## **7.24 Automatic Set Relocation**

If your installer has equipped your system with automatic set relocation, when you move your telephone to a new location, the system will give you a choice (through a display prompt) as to whether you want to keep your previous programming or use the programming in the new location.

- To maintain the extension number and programming features from the old location,
  1. Connect the telephone line cord to the new jack.
  2. Press **YES** to retain the extension number and programming from the previous location.
- To assume the extension number and programming features of the new location,
  1. Connect the telephone line cord to the new jack.
  2. Press **NO**.

## **7.25 Using The IMIST Module**

*Impact* SCS 8412F-\*\*, and 8412S-\*\* speakerphones equipped with the optional IMIST module can support an IST device (modem, FAX machine, industry-standard telephone, etc.) in addition to the LCD speakerphone. Depending on system programming, the IST device may be used to make outgoing calls and receive incoming calls.

The functionality of the IMIST module depends on the type of system you are using.

- The IMIST module will function on a DXP system with the appropriate digital station board, but the IMIST module will not have its own extension number and will not function simultaneously with the speakerphone.
- On a DXP *Plus* system, the IMIST module will function simultaneously with the speakerphone and have its own extension number if your system has the appropriate digital station board and memory board. If your system does not have the optional enhanced memory board, the IMIST module will function like the one on the DXP system described above.
- On an FX Series system, the speakerphone and IMIST module can function simultaneously and the IMIST module has its own extension number.

**NOTE:** *The IMIST module does not provide voltage to light a message waiting light. Message waiting lights on devices plugged into the IMIST module will not function.*

If you have any other questions about IST devices, refer to GCA70-237, *Industry-Standard Telephone Station User's Guide*.

**NOTE:** *The IMIST module has a separate power supply. The wall transformer is a UL and CSA approved Class 2 device operating from 120 Vac, 60 Hz, 16 watts and provides an output of 24 Vac at 450 mA. For replacement, order Comdial P/N DIU-PTR.*

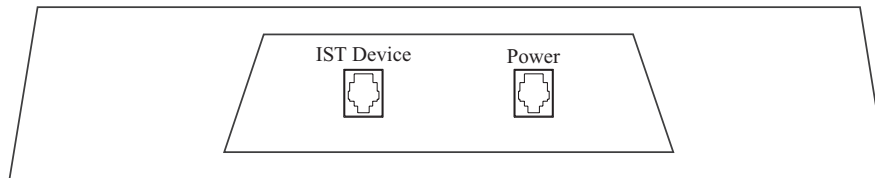

scs05

IMIST Module

## **7.26 Using The Caller ID Feature**

The Caller ID feature allows you to view incoming call numbers before you answer them. Incoming call numbers flash in the lower half of the LCD. If you answer the call, the number appears in the upper half of the LCD.

The system also stores numbers that ring on your line but receive no answer. The system indicates that it has stored ring-no answer numbers by causing the CID light on your telephone to flash. Pressing the **CID** button allows you to view the stored numbers one at time. Pressing the **SAVED NUMBER REDIAL** button causes the system to dial the displayed number. If the call has been returned by someone else, pressing the \* key reveals who returned the call. Everyone sharing your line can scroll through the stored numbers and choose which calls to return.

**NOTE:** *If your system installer has not programmed a **SAVED NUMBER REDIAL** button, refer to section 9.4, Using The Feature Buttons, for instructions on programming this button.*

- To scroll through ring-no answer numbers stored on your system,
  1. If your CID light is flashing, the system has unreturned ring-no answer numbers stored in memory.
  2. To view the list of unreturned ring-no answer number, press the preprogrammed **CID** button on your telephone. Your LCD will display the calling number, date, and time the call came in. The most recent call appears first in the list.
  3. Press the **CID** button each time you wish to display the next most recent ring-no answer call to your line.
  4. To dial one of the numbers in the redial queue, press the **SAVED NUMBER REDIAL** button.

Depending on your system programming, when a call is returned it might remain in the ring-no answer queue or the system might delete it from the ring-no answer queue. Your system installer can tell you how the feature is programmed. If the system is programmed to leave a returned number in the redial queue, the display will show a \* next to numbers that have been returned.

- To determine who viewed the number and returned the call,
  1. Press \*.



## **7.27 Viewing The Call Log**

The Call Log feature allows you to view the last 10 outgoing calls made from your station. If you have caller ID, the LCD will also display incoming calls. Incoming calls are designated with an **I** next to the number and outgoing calls are designated with an **O**.

- To view the call log,
  1. Press the **OPTIONS** button.
  2. Press the **CALL LOG** button.

The LCD displays the last 10 phone numbers you dialed (or the numbers that called you, if you have caller ID). Incoming calls are designated with an **I** to the left of the number and outgoing calls are designated with an **O**.
  3. To scroll through the lists of numbers, press the **NEXT** or **PREV** buttons.
  4. To display the time of a call, press the corresponding button to the right of the LCD.
  5. Press **EXIT** when you are done.

*This page remains blank intentionally.*



## **Sending And Receiving Non-Verbal Messages**

### **8.1 Message Waiting Light And Messaging**

If the system installer designates your LCD speakerphone as a *central message desk* or programs it to have message-wait originate ability, you can turn on the message-waiting light of any other telephone. This light lets that telephone user know that you have a message for him or her. In addition to the message waiting light, leaving a message indication at a station that is a prime intercom, also causes the dial tone at that station to sound in a broken manner when the station user takes his or telephone off-hook.

If a telephone that receives a message has a DSS button that is programmed to call the station that left the message, the light next to that DSS button on the message-receiving station will flash.

- To turn on the message-waiting light (and a broken dial tone) at another station that is idle or busy,
  1. Press **INTERCOM**.
  2. Dial \* **3**.
  3. Dial extension number of station to be alerted. The message-waiting light of called station will flash.
  
- You can also turn on the message-waiting light and broken dial tone at another station when that station is busy,
  1. Hear the busy tone and remain on the line.
  2. Press **MESSAGE**.
  3. Hang up.

- To turn off the message waiting light at a busy or idle station,
  1. Press **INTERCOM**.
  2. Dial # **3**.
  3. Dial extension number of station that was alerted. The message-waiting light of called station will turn off.
  
- To turn off the message-waiting light during message-delivering conversation,
  1. Press **INTERCOM** once if off-hook, twice if on-hook.

***NOTE: Only the person who sent the message and the person receiving the message can turn the indicator off.***

- To receive a message at an alerted station,
  1. Observe flashing message waiting light and the LCD message indicating who called for you.
  2. Press **CALL** to dial the messaging station automatically,  
—OR—  
press **CLEAR** to clear the message from your station.

## **8.2    Sending LCD Messages**

You can set system-supplied messages at your station to be received and displayed by a calling LCD speakerphone. These messages give the caller information on your telephone status. Get a list of the available messages from the attendant and write them on the blank chart on the next page.

- To turn on a message from your telephone,
  1. Press **OPTIONS**, then press **PROGRAM**.
  2. Press **NEXT** until **LCD MESSAGING** appears.
  2. Select the message you would like to appear in a calling party's LCD by pressing the corresponding interactive button. If you need to scroll through the list of available messages, press the **NEXT** button.

If you use the default messages *Back at* and *Call*, add to them as follows:

For *Back at* message, dial the code for time numbers and colon from dialing codes table on the next page (for example, dial # **00 01 29 04 05** for the time 01:45).

For *Call* message, dial code for telephone number of where you'll be (for example, dial # **09 07 08 15 02 02 00 00** for the number 978-2200).

3. Press **DONE**, then press **EXIT** to end message.
  4. Intercom light flashes.
- To turn off the message and your intercom light,
    1. Press the **CLEAR** button.

<b>Dialing Code Table</b>			
<b>Character</b>	<b>Dialing Code</b>	<b>Character</b>	<b>Dialing Code</b>
1	01	8	08
2	02	9	09
3	03	0	00
4	04	space	12
5	05	–	15
6	06	:	29
7	07		

### **8.3 Sending Response Messages**

By programming one or more **RESPONSE MESSAGE** buttons on your LCD speakerphone, you can respond with a variety of messages to many calling situations. For example, if you call another station and receive a busy signal or no answer, you can send one of 30 system-supplied messages, or you can send the same message each time the situation arises. Further, you may at times receive intercom or SOHVA calls that you decide not to answer, and you can send a message to the display of the calling LCD speakerphone for the caller to read.

If you program a scrolling **RESPONSE MESSAGE** button at your telephone, you may use it to scroll through and select any of the system's messages to send, allowing you to send a different message every time. If you program a fixed **RESPONSE MESSAGE** button, you can send the same message every time in response to a situation, which saves you the trouble of scrolling to the message you want to send.

This section tells you how to use the **RESPONSE MESSAGE** button(s) to send messages to other LCD speakerphones. Refer to section 10.1 for instructions on programming the **RESPONSE MESSAGE** button(s).

- To send an LCD message when you call and receive busy signal or no answer,
  1. While still on the call, press the appropriate fixed **RESPONSE MESSAGE** button to send a preselected message (*Call [your name]*, for example) to the other telephone,  
—OR—  
while still on the call, press the scrolling **RESPONSE MESSAGE** button to scroll through the system-supplied messages.
  2. Press # when your display shows the message you wish to send (the message will then be displayed at the called telephone).

**NOTE:** *For the example in step 1, you would use default message 2. Your name would then be added from the station name programming done by the installer.*

- To send an LCD message to a caller who has initiated a SOHVA or intercom call from another LCD telephone,
  1. Hear the SOHVA tone or voice announcement.
  2. Press the appropriate fixed **RESPONSE MESSAGE** button to send a preselected message (*I Will Call Back*, for example) to the calling telephone,  
—OR—  
while still on the call, press the scrolling **RESPONSE MESSAGE** button to scroll through the system-supplied messages.
  3. Press # when your display shows the message you wish to send (the message will then be displayed at the calling telephone and the SOHVA call will be terminated).





## **Programming Your Telephone**

### **9.1 Programming For Speed Dialing**

Speed dialing is a feature that lets you:

- store and dial lengthy numbers using one or two buttons,
- store and dial intercom numbers of frequently called telephones,
- store frequently used feature codes.

You can store numbers for speed dialing at the following locations:

- at any programmable button that is ***not now assigned as a line button or other feature*** by the system administrator or installer,
- at the keypad numbers 0-9 (primary level only),
- on a secondary level at any of the programmable button locations.

Before you begin programming, write down the intercom or outside line you will use and the number digits that you are storing. Then, as you program the speed dial numbers, write the first and second level numbers on your telephone's ID strips. You can also fill out the charts on the next page, if you wish, for a personal record of your stored numbers.

***NOTE: The Federal Communications Commission (FCC) requires that when programming emergency numbers and/or making test calls to emergency numbers:***

- 1. Remain on the line and briefly explain to the dispatcher the reason for the call.***
- 2. Perform such activities in the off-peak hours, such as early morning or late evening.***

<b>Speed Dial Numbers</b> (Programmable Buttons)			
1		7	
2		8	
3		9	
4		10	
5		11	
6		12	

<b>Personal Speed Dial Numbers</b> (Keypad Buttons)			
1		6	
2		7	
3		8	
4		9	
5		10	

## **9.2 Storing Speed Dial Numbers**

- To store an outside number as a speed dial number, follow the display prompts and proceed as follows:

**NOTE:** *Programming overwrites existing speed dial numbers at button locations.*

1. Press **OPTIONS**, then press **PROGRAMMING**.
2. Press **NEXT** until **SPEEDDIAL** option appears.
3. Press **SPEEDDIAL** to choose speed dial programming.
4. Press programmable button or dial pad button (**0-9**) to choose storage location (remember, to access second level storage at a programmable button, press **SHIFT** first).
5. Press **EDIT**.
6. Make your speed dial route selection choice from the list on the LCD by pressing the appropriate button.
7. Dial number (up to 16 digits long—include \* and # if needed).

You may need a pause between numbers to compensate for differences in response time between your system and the host system (ask your attendant about this).

To store a pause, press the **PAUSE (p)** button.

To store a flash (switchhook), press the **FLASH (f)** button.

If you need to erase the typed digits appearing in your display to correct them, use the interactive buttons on either side of the top row of numbers and digits to place the cursor under the character you want to remove. Press the **ERASE** button at the bottom of the LCD to remove the letter.

8. Press **DONE** to store the number.
9. Press next location button and store next number, repeat previous steps until all numbers are stored,

—OR—

press **EXIT**.



## **9.4 Using The Feature Buttons**

You can create feature access buttons to make telephone operation easier. To do this, use the interactive buttons to select the feature you want to store, and then store it on a programmable button (see the instructions on the next page).

**Account Code Button (ACCT)**—allows you to enter an account code for call record purposes.

**Call Forward Button (CFWD)**—allows you to forward all of your calls to another telephone.

**Camp-On With Automatic Call Back (CAMP)**—allows you to camp on to a station. The system calls you back as soon as the called station becomes idle or occupied.

**Camp-On (Call Waiting) (CAMP)**—when calling a busy station, this feature allows you to send a call waiting tone to the station and to wait on-line for a reply.

**Clear Features (CLEAR)**—clears a currently active or engaged feature.

**Do Not Disturb Button (DND)**—prevents other telephones from ringing your telephone.

**Group Listen Button (GPLSN)**—allows others to hear a conversation over the telephone speaker while you use the handset or headset; the distant party can hear only the conversation transmitted through the handset or headset microphone.

**Music Button (MUSIC)**—allows you to enable or disable background music; also allows you to choose from two preprogrammed music sources.

**Page Button (PAGE)**—provides one-button access to paging.

**Park Button (PARK)**—parks calls in preselected park orbit.

**Pick-Up Button (PCKUP)**—allows you to pick up a call ringing elsewhere in your system.

**Privacy Release Button (PRIV)**—releases privacy for current call.

**Saved Number Redial Button (SAVE)**—redials the last number saved at this button location (good for short-term storage).

**Voice-Announce Block Button (VAB)**—blocks voice announcements.

- To create a feature access button,
  1. Press **OPTIONS**, then press **PROGRAMMING**.
  2. Press **NEXT** until the **FEATURE BUTTON** option appears.
  3. Press **FEATURE BUTTON**.
  4. Select the Feature Level (1 or 2) by pressing the **FEATURE LEVEL** button to the right of the LCD.
  5. Select one of the four options (**SELECT FEATURE LOCATION**, **SHOW EMPTY LOCATIONS**, or **SHOW ALL LOCATIONS**) by pressing the corresponding button to the left of the LCD.
  6. Select the button you want to assign as a feature button.
  7. Select the feature you want to assign to by pressing the corresponding button to the left of the LCD. (Press **NEXT** to scroll through the list of available features.
  8. Repeat steps 1–6 to assign additional feature buttons.
  9. Press **EXIT** when you are done.
  
- To clear a feature button assignment,
  1. Repeat the above procedure, but press **EXIT** once you have selected the feature button.

## **9.5 Storing A Response Message Button**

A fixed **RESPONSE MESSAGE** button allows you to send an LCD message to a caller who has initiated a SOHVA or intercom call from another LCD telephone, or to send an LCD message to another LCD telephone that you call and receive a busy signal or no answer.

A fixed **RESPONSE MESSAGE** button will send the same preselected message every time you press it. For example, if you know that you want to send the message *I Will Call Back* every time you receive a SOHVA, program a fixed **RESPONSE MESSAGE** button with that message and label the button accordingly.

- To store a fixed **RESPONSE MESSAGE** button,
  1. Press **OPTIONS**, then press **PROGRAMMING**.
  2. Press **NEXT** until the **FEATURE BUTTON** option appears.
  3. Press the **FEATURE BUTTON** option.
  4. Select the programmable button you wish to use as a response message button.
  5. Press **NEXT** until the **RESPONSE MESSAGE** option appears.
  6. Select the **RESPONSE MESSAGE** option.
  7. Select from the list of displayed messages. Press the **NEXT** button to scroll through the list of messages.

If you use the *Back at* or *Call* options, add to them as follows:

For *Back at* message, dial the code for time numbers and colon from dialing codes table on page 8-4 (for example, dial # **00 01 29 04 05** for the time 01:45).

For the *Call* message, dial the code for telephone number where you can be reached (for example, dial # **09 07 08 15 02 02 00 00** for the number 978-2200).

8. To program another fixed response message button, repeat steps 4-7.

—OR—

Press **EXIT**.

**NOTE:** Your system installer can also program response messages.

## **9.6 Storing Access Codes**

You can store feature access codes at programmable buttons to provide yourself with one-button access to features that you use quite often. To find your feature codes of interest, turn to the *Quick Reference Guide* that is located at the end of this publication.

Remember, your LCD speakerphone provides interactive buttons that eliminate almost every need for feature code dialing. Further, the installer may store frequently-used features at your telephone buttons and label the buttons with the feature's mnemonics. Finally, you can follow the instructions provided in section 9.4 to directly assign feature buttons without having to store their feature dialing codes.

- To store an access code,
  1. Press **OPTIONS**, then **PROGRAMMING**.
  2. Press **NEXT** until you see the **FEATURE BUTTON** option.
  3. Press **FEATURE BUTTON**.
  4. Select the programmable button at which you wish to store the feature (remember, if there is anything else programmed at this button, the new programming will overwrite it). For help in selecting a button, press **SHOW EMPTY LOCATIONS** to display unused feature buttons. To display all feature buttons (used and unused), press **SHOW ALL LOCATIONS**.
  5. The speakerphone will now display a list of features which you can scroll through by pressing **NEXT**.
  6. Select the feature you wish to assign to the programmable button.
  7. If you wish to program more feature buttons, repeat steps 4–6. Otherwise, press **EXIT**.



## **9.7 Setting A Reminder Alert**

You can set up to two reminder alerts to sound at your LCD speakerphone so that you will remember important regular events (a daily 10:00 meeting or a daily conference call, for example) or occasional events (classroom training, appointments, etc.).

When an alert sounds at the set time, you will hear four short tone bursts, which will continue until acted upon. If you are not at your station to hear the alert when it sounds, your telephone's ring tone will change to the alert tone for every incoming call until you respond to the alert.

- To set a reminder alert at your telephone,
  1. Press **OPTIONS**, then press **PROGRAMMING**.
  2. Press **NEXT** until the **REMINDER ALERT** option appears.
  3. Press the **REMINDER ALERT** button.
  4. Select the reminder alert you want to set (Reminder Alert 1 or Reminder Alert 2) by pressing the corresponding button to the left of the LCD.
  5. Dial reminder time using the numbers on the dial pad (remember to add a zero [0] before single digit times: 01 for one o'clock, 02 for 2 o'clock, etc.).
  7. Set **AM** or **PM** by pressing the button to the right of the displayed time.
  8. Turn the reminder alert on by pressing the button beside the reminder alert (to the right of the LCD).
  9. Press **EXIT**.
  
- To respond to an alert after it sounds,
  1. Press the **CLEAR** button (to the right of the Alert display) to turn off the alert,  
—OR—  
press the button to the left of the alert display to reset the alert for the same time the following day.

*This page remains blank intentionally.*

**10****Using The Attendant Features****10.1 Using The Special Attendant Buttons**

In addition to the many feature buttons the system can make available to any station, the DXP provides the attendant position with several special-purpose feature buttons to enhance call processing. These special-purpose buttons are described below:

**Alternate Button:** When an attendant presses this button, all calls normally routed to his or her telephone are then routed to an alternate attendant's telephone instead. In some cases, your alternate attendant will be able to route all calls to a third alternate attendant.

**Both Button:** This button provides a means for an attendant to establish a conference between the attendant's station, a current call, and the last call that was placed on hold.

**Overflow Button:** When an attendant presses this button, calls that normally ring at the attendant's telephone also ring at an overflow attendant's station.

**Queue Button:** When multiple calls are ringing or are on hold at an attendant's station, the system places them in a queue. The attendant can use this button to determine how many calls are queued awaiting service.

**Serial Call Button:** When a caller wishes to speak to more than one person, the attendant uses this button to place the caller in a serial mode of multiple transfers to each desired party. In the serial mode the system automatically transfers the caller to another party as soon as a present party hangs up. The system places the caller in the serial mode as soon as the attendant hangs up.

**Test/Busy Button:** This button provides the attendant with a means to test the status of specific lines. Attendants can use this button to determine whether individual lines are idle, busy or on hold. When this button is used, the line is seized if it was idle.

- To forward all calls to an alternate attendant,
  1. Press the installer-programmed **ALTERNATE** button. If an alternate attendant is programmed, the light next to the **ALTERNATE** button will illuminate and the LCD will indicate the location of the alternate attendant.
  
- To cancel the alternate mode,
  1. Press the **ALTERNATE** button again.
  
- To establish a conference between the attendant station, a held call, and an active call,
  1. Press the installer-programmed **BOTH** button.
  
- If you wish to cancel the conference condition and return one of the lines to hold,
  1. Press **HOLD**.
  2. Press the line button for the held call you wish to re-engage. The other line remains on hold at your speakerphone.
  
- To direct incoming calls to an overflow attendant during peak calling periods,
  1. Press the installer-programmed **OVERFLOW** button. If an overflow attendant is programmed, the light next to the **OVERFLOW** button will illuminate, and incoming calls will ring at both stations.
  
- To cancel,
  1. Press the **OVERFLOW** button again.

- To determine how many calls are queued at the attendant position and awaiting service (on hold, parked, or ringing),
  1. Press the installer-programmed **QUEUE** button. The display will indicate how many calls are in the ring queue and the hold queue, respectively. The displayed information remains in the LCD window momentarily.

**NOTE:** *Hold recalls, transfer recalls and park recalls are counted in the ring queue and not the hold queue.*

- To place an active call in a serial transfer,
  1. Press the installer-programmed **SERIAL** button.
  2. Dial intercom number or press associated DSS button.
  3. Repeat to add up to two more extensions to the serial.
  4. Press **SPEAKER** to end. Serial transfer begins.
  
- To determine the status of individual lines (idle, busy or on hold),
  1. Press the installer-programmed **TEST/BUSY** button (the LCD will display the prompt *Enter Line:*).
  2. Dial the line number to be tested (001-128). If the line is idle, you will hear a dial tone; if the line is busy, the LCD will display *Busy with xxx*; if the line is on hold, the LCD will display *On Hold at xxx* (xxx = line number).

## ***10.2 Viewing The System Status Log***

The system status log gives you information about the status of your system. Status log entries include: system reset, parity (port number), (port number) removed, manual reset, and software reset. Your installer must program a **SYSTEM STATUS** button on your telephone to provide you with access to the log display. The light located next to the button serves as the **SYSTEM STATUS** light. If the light turns on, it alerts you to enter the log viewing mode by pressing the **SYSTEM STATUS** button.

If your system includes T1 telephone line service, your telephone may display a T1 status log as well as the system status log. The T1 status log entries include those transmission errors that exceed their installer-programmed thresholds.

The installer may arrange for the system to sound an external audible alarm (or turn on an external visual alarm) if certain alarm conditions occur with the T1 service— it is the installer's choice whether the external alarm is audible or visual. If a T1 alarm occurs, you must take action to turn off the alarm device.

View the status logs by scrolling through them using the interactive buttons on your telephone. Although you can view a status log and turn off the T1 alarm, your installer must turn off your **SYSTEM STATUS** light. After viewing a log (and also turning off the external T1 alarm if necessary), inform the system administrator or installer that a system status or T1 alarm condition has occurred, and describe to him or her the displayed log details.

- To view the log,
  1. Press the **SYSTEM STATUS** button (the button flashes red when the log contains entries).
  2. Press the **SYSTEM** interactive button to display the most recent system status log entry,  
—OR—  
press **T1** interactive button to display the most recent T1 log entry.
  3. Press the **INFO** interactive button to display the time and date of the current entry.
  4. Press the **REV** interactive button to display the previous entry.
  5. Press the **FWD** interactive button to display the next (more recent) entry.
- To display the number of entries in the log,
  1. Press the **#** button at any time.
- To exit the log viewing mode,
  1. Either press the **SPEAKER** button, press the hookswitch, or wait for the 15-second time-out.
- To turn off the external T1 alarm,
  1. Press **INTERCOM**.
  2. Dial **# 0 9**.
  3. Press **SPEAKER** to end.

### 10.3 Operating Your Telephone With A DSS/BLF Console

The IB48X, and IB24X DSS/BLF consoles have additional buttons and status lights that extend the memory button capability of an adjacent companion telephone. The buttons can be programmed for automatic dialing (speed dial) or direct station selection (DSS) with busy lamp field (BLF) using the instructions provided previously in this guide.

When the installer assigns a DSS/BLF console to a station port, the system recognizes it as such and automatically clears (blanks) the console buttons so that you can store numbers at the buttons as you need them.

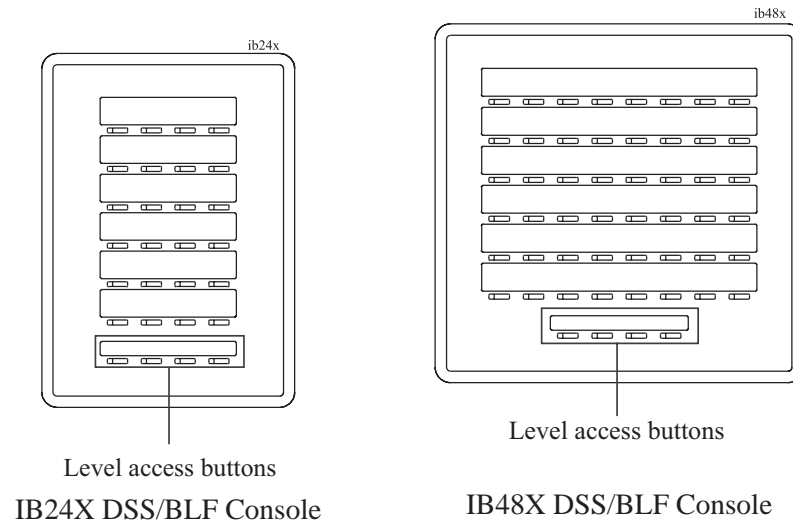



***10.3.1 Accessing The Button Levels***

The IB24X and IB48X DSS/BLF consoles have four levels of buttons, quadrupling the consoles' button capacity. The four buttons at the bottom of each console allow you to select which button level is currently active. To change button levels, press one of the buttons at the bottom of the console. The leftmost button activates level 1, the next button activates level 2, etc. A light beside the appropriate button lights to indicate which level is currently active.

*This page remains blank intentionally.*

# 11

## Troubleshooting Your Telephone

Symptom	Possible Cause
INTERCOM light flashing.	Your messaging is set. Press INTERCOM, then dial # 02 and hang up.
MUTE light on.	MUTE is activated. To cancel, press MUTE.
SPEAKER light on steady.	Background music feature activated even though the system does not provide background music. To cancel, press INTERCOM then dial # 1.
Error Tone (three steady tones)	May occur when incorrect buttons are pressed during speed dial programming. For example, if a button has a line assigned to it, or was not enabled for speed dial programming by the installer.
You cannot receive a voice announce call.	Voice announce block has been activated. To cancel, press INTERCOM then dial # 2.

*This page remains blank intentionally.*

**Index****A**

- Access Codes, Storing . . . . . 9-8
- Account Codes, Entering . . . . . 7-4
- Adjusting The Display Contrast . . . . . 7-1
- Adjusting The Telephone Pedestal . . . . . 1-17
- Answering Calls . . . . . 2-1
- Answering Calls At Monitored Stations . . . . . 2-3
- Answering Intercom Calls . . . . . 2-2
- Answering Night-Transferred Calls . . . . . 2-4
- Answering Outside Calls . . . . . 2-1
- Attendant Buttons, Using The Special . . . . . 10-1
- Attendant Features, Using The . . . . . 10-1
- Authorization Codes, Entering . . . . . 7-5
- Automatic Redial Feature . . . . . 3-5 — 3-6
- Automatic Set Relocation . . . . . 7-28

**B**

- Blocking Voice-Announce Calls . . . . . 7-1
- Busy Button Inquiry . . . . . 7-2
- Busy Line And Station Status, Displaying . . . . . 7-2
- Button Functions, Displaying . . . . . 7-3
- Button Levels, Accessing On DSS/BLF Consoles . . . . . 10-7
- Button Query . . . . . 7-3

**C**

- Call, Listening Over The Telephone Speaker (Group Listening) . . . 7-7
- Call Log . . . . . 7-31
- Call, Making A Non-Private . . . . . 7-8
- Call, Overriding At Another Station . . . . . 3-13
- Call Pick-Up, Making A . . . . . 2-5
- Call Waiting . . . . . 3-12
- Caller ID Feature . . . . . 7-30
- Calls, Answering At Monitored Stations . . . . . 2-3

Calls, Answering Intercom . . . . .	2-2
Calls, Answering Night Transferred . . . . .	2-4
Calls, Answering Outside . . . . .	2-1
Calls, Blocking Voice Announce . . . . .	7-1
Calls, Diverting To Another Station . . . . .	7-3
Calls, Forwarding . . . . .	7-6
Calls, Holding . . . . .	4-1
Calls, Making . . . . .	3-1
Calls, Making Intercom. . . . .	3-10
Camping On At A Busy Station And Waiting For An Automatic Callback . . . . .	3-11
Camping On At A Busy Station And Waiting For An Answer . . . . .	3-12
Camping On At An Idle Station And Waiting For An Automatic Callback . . . . .	3-12
Conferencing Calls . . . . .	6-1
Conferencing Telephones Together . . . . .	6-1
Contrast, Adjusting The Display . . . . .	7-1

**D**

Dial By Name Feature . . . . .	3-3
Dialing Automatically . . . . .	3-2
Dialing Manually . . . . .	3-1
Direct Inward System Access, Using . . . . .	7-17
Display Abbreviations, Understanding The . . . . .	1-10 — 1-12
Display Contrast, Adjusting The . . . . .	7-1
Displaying Status Of Busy Lines And Stations. . . . .	7-2
Displaying Button Functions (Button Query) . . . . .	7-3
Diverting Incoming Calls To Another Station . . . . .	7-3
Do Not Disturb Condition, Overriding A . . . . .	3-13
Do Not Disturb Condition, Setting At Your Station . . . . .	7-12
DSS Numbers, Storing . . . . .	9-4
DSS/BLF Console, Using . . . . .	10-6

**E**

- E and M Tie Lines, Using . . . . . 7-23
- Entering Account Codes . . . . . 7-4
- Entering Authorization Codes . . . . . 7-5

**F**

- Feature Buttons, Storing The . . . . . 9-5 — 9-6
- Forwarding Calls . . . . . 7-6
- Full-Duplex Speakerphone, Using A . . . . . 1-3 — 1-4

**G**

- Group Listening . . . . . 7-7

**H**

- Half-Duplex Speakerphone Guidelines . . . . . 1-5
- Handing Hold Recalls . . . . . 4-4
- Handling Park Recalls . . . . . 4-6
- Headset, Installing . . . . . 1-8
- Headset, Using Your . . . . . 1-8
- Hold Button . . . . . 1-13
- Hold, Placing Calls On . . . . . 4-1
- Hold Recalls, Handling . . . . . 4-4
- Holding Calls . . . . . 4-1
- Hot Transfer . . . . . 5-4

**I**

- IMIST Module . . . . . 7-29
- Interactive Buttons . . . . . 1-13
- Intercom Button . . . . . 1-13
- Intercom Calls, Answering . . . . . 2-2
- Intercom Calls, Making . . . . . 3-10
- Introducing The LCD Speakerphone . . . . . 1-1

**K**

- Knowing Your Speakerphone's Functions . . . . . 1-13

**L**

- Large Screen Display, Understanding The . . . . . 1-9
- Last Number Redial. . . . . 3-4
- LCD. . . . . 1-13
- LCD Messages, Sending . . . . . 8-3
- Lighting The Message Waiting Light . . . . . 8-1
- Lights, Understanding What They Mean . . . . . 1-15 — 1-16
- Line Groups, Using . . . . . 3-8
- Listening To A Call Over The Telephone Speaker. . . . . 7-7

**M**

- Making a Subdued Off-Hook Voice Announcement . . . . . 3-14
- Making A Call Non-Private . . . . . 7-8
- Making A Call Pick-Up. . . . . 2-5
- Making A Hot Transfer. . . . . 5-4
- Making Calls . . . . . 3-1
- Making Intercom Calls . . . . . 3-10
- Message-Waiting Light. . . . . 1-14
- Message-Waiting Light, Lighting The . . . . . 8-1
- Messages, Sending And Receiving Non-Verbal Messages. . . . . 8-1
- Messages, Sending LCD . . . . . 8-3
- Messages, Sending Response . . . . . 8-5
- Microphone Opening. . . . . 1-14
- Monitoring A Conversation Between Two Telephones . . . . . 7-9
- Music, Using Background. . . . . 7-16
- Mute Button. . . . . 1-14
- Muting Your Telephone . . . . . 7-10

**N**

- Night Transferred Calls, Answering . . . . . 2-4

**O**

- Outside Calls, Answering . . . . . 2-1
- Overriding A Call Or A Do Not Disturb Condition
  - At Another Telephone . . . . . 3-13



**P**

- Paging, Sending An Announcement . . . . . 7-10
- Park Recalls, Handling . . . . . 4-6
- Parking Calls . . . . . 4-5
- Pedestal, Adjusting The Telephone . . . . . 1-17
- Personal Ring Tones, Setting Your . . . . . 7-15
- Placing Calls On Hold . . . . . 4-1
- Privacy, Making A Call Non-Private . . . . . 7-8
- Privacy Release . . . . . 7-8
- Programmable Buttons . . . . . 1-14
- Programming For Speed Dialing . . . . . 9-1
- Programming Your Telephone . . . . . 9-1
- Pulse And Tone, Switching The Dialing Mode . . . . . 7-16

**Q**

- Queuing . . . . . 3-9
- Quick Reference Guide . . . . . Quick Reference-1
- Quick Transfer, Using . . . . . 5-5

**R**

- Redial Feature, Automatic . . . . . 3-5 — 3-6
- Redial Queue . . . . . 3-5 — 3-6
- Redialing A Previously Dialed Number . . . . . 3-4
- Redialing A Saved Number . . . . . 3-7
- Redialing Last Dialed Number . . . . . 3-4
- Relocation, Automatic Set . . . . . 7-28
- Reminder Alert, Setting A . . . . . 9-9
- Responding To A Subdued Off-Hook Voice Announcement . . . . . 2-6
- Response Message Button, Storing A . . . . . 9-7
- Response Messages, Sending . . . . . 8-5 — 8-6

**S**

- Saved Number Redial . . . . . 3-7
- Sending A Paging Announcement . . . . . 7-10
- Sending And Receiving Non-Verbal Messages . . . . . 8-1

---

Sending LCD Messages . . . . .	8-3
Sending Response Messages . . . . .	8-5
Service Observing . . . . .	7-9
Set Relocation, Automatic. . . . .	7-28
Setting A Do Not Disturb Condition At Your Station . . . . .	7-12
Setting A Reminder Alert . . . . .	9-9
Setting The Volume Control . . . . .	7-13 — 7-15
Setting Your Personal Ring Tones . . . . .	7-15
Shift Button . . . . .	1-14
Speaker . . . . .	1-14
Speakerphone, Introduction. . . . .	1-1
Speakerphone User Guidelines . . . . .	1-3
Speakerphone, Using Your Full-Duplex. . . . .	1-3 — 1-4
Speakerphone, Using A Half-Duplex . . . . .	1-5
Speed Dial Numbers, Storing . . . . .	9-3
Speed Dialing, Programming For . . . . .	9-1
Speakerphone's Functions, Knowing Your. . . . .	1-13 — 1-15
Status Log, Viewing The System . . . . .	10-4
Storing Access Codes . . . . .	9-6
Storing DSS Numbers . . . . .	9-4
Storing Speed Dial Numbers. . . . .	9-3
Storing The Feature Buttons . . . . .	9-5 — 9-6
Storing A Response Message Button . . . . .	9-7
Switching The Dialing Mode Between Pulse And Tone . . . . .	7-16
Subdued Off-Hook Voice Announcement, Making A . . . . .	3-14
Subdued Off-Hook Voice Announcement, Responding To . . . . .	2-6
Switching The Dialing Mode Between Pulse And Tone . . . . .	7-16
System Status Log, Viewing The . . . . .	10-4

## **T**

TAP Button . . . . .	1-14
Telephone Pedestal, Adjusting . . . . .	1-17
Tracker Paging System, Using The. . . . .	7-20 — 7-22
Transfer/Conference Button . . . . .	1-15
Transfer, Making A Hot . . . . .	5-4

---

Transferring Calls . . . . .	5-1
Transferring Calls—Screened . . . . .	5-1
Transferring Calls—Unscreened . . . . .	5-3
Transferring Calls Using Quick Transfer . . . . .	5-5
Troubleshooting Your Telephone . . . . .	11-1

**U**

Understanding The Display Abbreviations . . . . .	1-10 — 1-12
Understanding What The Lights Mean . . . . .	1-15 — 1-16
Using A Full-Duplex Speakerphone . . . . .	1-3 — 1-4
Using Background Music . . . . .	7-17 — 7-19
Using Direct Inward System Access . . . . .	7-19
Using E and M Tie Lines . . . . .	7-23
Using Line Groups . . . . .	3-8
Using Quick Transfer . . . . .	5-5
Using The Attendant Features . . . . .	10-1
Using The Feature Buttons . . . . .	9-5
Using The IMIST Module . . . . .	7-29
Using The Other Telephone Features . . . . .	7-1
Using The Tracker Paging System . . . . .	7-20 — 7-22
Using This Guide . . . . .	1-1
Using Your Speakerphone . . . . .	1-3

**V**

Viewing The System Status Log . . . . .	10-4
Voice Announce Calls, Blocking . . . . .	7-1
Volume Control, Setting The . . . . .	7-13

**W**

Waiting For A Line . . . . .	3-9
------------------------------	-----

*This page remains blank intentionally.*

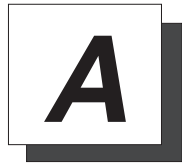

## **Appendix A** **Quick Reference Guide**

This chart provides you with a Quick Reference Guide of the feature dialing codes. If you wish, you can detach these pages and keep them near your telephone to serve as a stand alone reference. Chapter 8, *Programming Your Telephone*, describes a method to program these codes on your telephone at unused programmable buttons. Also, the installer may store features at your telephone buttons and label the buttons with the feature's mnemonics.

<b>Feature</b>	<b>Enable Code</b>	<b>Disable Code</b>	<b>Button Mnemonic</b>
<b>Account Code</b>	<b>INTERCOM * 04 + account code</b>		<b>ACCT</b>
<b>All Call</b>	<b>INTERCOM 70</b>		<b>PAGE 1</b>
<b>Attendant Calling</b>	<b>INTERCOM 0</b>		
<b>Authorization Code</b>	<b>INTERCOM # 08 + authorization code</b>		<b>AUTH</b>
<b>Automatic Callback and Call Waiting</b>	<b>INTERCOM * 6</b>	<b>INTERCOM # 6</b>	<b>CAMP</b>
<b>Automatic Redialing</b>			<b>ARD</b>
<b>Background Music</b>	<b>INTERCOM * 11 or 12</b>	<b>INTERCOM # 1</b>	<b>MUSIC 1 MUSIC 2</b>
<b>Call Divert Station</b>	<b>INTERCOM * 55 + extension number</b>		
<b>Call Forward, Personal</b>	<b>INTERCOM * 51 + extension number</b>	<b>INTERCOM # 5</b>	<b>FWD-P</b>
<b>Call Forward, All Calls</b>	<b>INTERCOM * 52 + extension number</b>	<b>INTERCOM # 5</b>	<b>FWD-A</b>

Feature	Enable Code	Disable Code	Button Mnemonic
Call Forward, Ring-No Answer, All Calls	INTERCOM * 54 + extension number	INTERCOM # 5	FWDRA
Call Forward, Ring-No Answer, Personal Calls	INTERCOM * 53 + extension number	INTERCOM # 5	FWDRP
Call Park, Orbit 910-999	INTERCOM * (910-999)		PARK 1-90
Call Park, Pickup	INTERCOM # (910-999)		PARK 1-90
Call Pickup, Directed	INTERCOM * 4 + extension number		DPKUP
Call Pickup, Group	INTERCOM # 4		GPKUP
Call Forward Outside System	INTERCOM * 56	INTERCOM # 5	
Clear Major Alarm Ring	INTERCOM # 09		
DISA Access	Installer Assigned		
Do Not Disturb	INTERCOM # 01		DND
Do Not Disturb Override	extension number + * 03		EXOVR
DSS Programming	INTERCOM ** 3		
Executive Override	extension number + *03		EXOVR
Hold, Manual	HOLD		HOLD
Hold, Exclusive	HOLD + HOLD		HOLD
Hold, Directed	INTERCOM * 90		
Hold, Directed Pickup	INTERCOM # 90		
LCD Messaging	INTERCOM * 02 + message	INTERCOM # 02	LCDMS

Feature	Enable Code	Disable Code	Button Mnemonic
Line Group 1	INTERCOM 9		LNG01
Line Groups 2-11	INTERCOM 80-89		LNG02-11
Line Groups 12-16	INTERCOM 60-64		LNG 12-16
Line Pick Up From Any Station, Zones 1-4	INTERCOM 65-68		TAFS 1-4
Line Pick Up From Any Station, All Zones	INTERCOM 69		TAFS*
Meet-Me Answer Page	INTERCOM 78		MMEPG
Message Waiting	INTERCOM * 3 + extension number	INTERCOM * 3 + extension number	
Message Wait Retrieval	#00		
Operator Access	INTERCOM 0		
Paging, All Call	INTERCOM 70		PAGE 1
Paging, Zones 2-8	INTERCOM 71-77		PAGE 2-8
Paging, Meet-Me	INTERCOM 78		MMEPG
Park Orbit Retrieve	INTERCOM #91-99		PARK 1-9
Park Orbit Send	INTERCOM *91-*99		PARK 1-9

Feature	Enable Code	Disable Code	Button Mnemonic
Personal Ringing Tones	INTERCOM ** 4 + tone code (1-8)		
Redial Last Dialed Number	#		
Remote Station Disable	INTERCOM * 05 + extension number	INTERCOM * 05 + extension number	
Response Message	INTERCOM ** 6 + button + 01-30		RSPnn (nn = 1-30, S)
Service Observing	INTERCOM # 03 + extension number		S-OBS
Speed Dial, Station	1-0		
Speed Dial, System	* 100 * 599		
Speed Dial, Programming	INTERCOM ** 1		
Station Lock	INTERCOM #04 + code		LOCK
Volume Save	INTERCOM ** 7		VOLSV
Voice-Announce Block	INTERCOM * 2	INTERCOM # 2	VABLK



***NOTE: The dialing codes provided in this quick reference guide are default values. Your system installer has the ability to renumber these codes.***

The following table details several unique dialing codes that are only applicable to single line proprietary and industry-standard telephones.

<b>Feature</b>	<b>Enable Code</b>
<b>Pick Up Last Line</b>	<b>* 08</b>
<b>Broker's Call</b>	<b>* 07</b>
<b>Speed Dial Access Code</b>	<b>* 01</b>
<b>Saved Number Redial</b>	<b>* 06</b>
<b>Dial Saved Number</b>	<b>* 09</b>
<b>TAP Dialing Code</b>	<b># #</b>

## **NOTES**

This manual has been developed by Comdial Corporation (the “Company”) and is intended for the use of its customers and service personnel. The information in this manual is subject to change without notice. While every effort has been made to eliminate errors, the Company disclaims liability for any difficulties arising from the interpretation of the information contained herein.

The information contained herein does not purport to cover all details or variations in equipment or to provide for every possible contingency to be met in connection with installation, operation, or maintenance. Should further information be desired, or should particular problems arise which are not covered sufficiently for the

**COMDIAL**®  
Charlottesville, Virginia 22901-2829  
World Wide Web: <http://www.comdial.com/>

Printed in U.S.A.

GCA70-349.02  
2/98

## Free Manuals Download Website

<http://myh66.com>

<http://usermanuals.us>

<http://www.somanuals.com>

<http://www.4manuals.cc>

<http://www.manual-lib.com>

<http://www.404manual.com>

<http://www.luxmanual.com>

<http://aubethermostatmanual.com>

Golf course search by state

<http://golfingnear.com>

Email search by domain

<http://emailbydomain.com>

Auto manuals search

<http://auto.somanuals.com>

TV manuals search

<http://tv.somanuals.com>