

VISION **120**
MODEL



1080p Digital Light Processing (DLP™) Projector

Vision 120

Vision 120/CineWide™

Vision 120/CineWide™ with AutoScope™

TWO YEAR LIMITED WARRANTY

For Projectors, Video Processors and Controllers

Congratulations on your purchase of a Vidikron video product and welcome to the Vidikron family! With proper installation, setup and care, you should enjoy many years of unparalleled video performance.

This is a LIMITED WARRANTY as defined in the Magnuson-Moss Warranty Act. Please read it carefully and retain it with your other important documents.

WHAT IS COVERED UNDER THE TERMS OF THIS LIMITED WARRANTY:

SERVICE LABOR: Vidikron will pay for service labor by Vidikron Authorized Service Center when needed as a result of manufacturing defect for a period of two (2) years from the effective date of delivery to the end user (excluding the lamp).

PARTS (not including the lamp): Vidikron will provide new or rebuilt replacement parts for the parts that fail due to defects in materials or workmanship for a period of two (2) years from the effective date of delivery to the end user. Such replacement parts are then subsequently warranted for the remaining portion (if any) of the original warranty period.

PROJECTOR LAMP: Vidikron will pay for service labor by a Vidikron Authorized Service Center when needed as a result of a manufacturing defect for a period of six (6) months or 1000 hours, whichever comes first, from the effective date of delivery to the end user. In addition, Vidikron will provide a new or rebuilt replacement lamp for the lamp that fails due to defects in materials or workmanship for a period of six (6) months or 1000 hours, whichever comes first, from the effective date of delivery to the end user. Such replacement lamps are then subsequently warranted for the remaining portion (if any) of the original warranty period.

WHAT IS NOT COVERED UNDER THE TERMS OF THIS LIMITED WARRANTY:

This Limited Warranty only covers failure due to defects in materials and workmanship that occur during normal use and does not cover normal maintenance. This Limited Warranty does not cover cabinets or any appearance items; failure resulting from accident, misuse, abuse, neglect, mishandling, misapplication, faulty or improper installation or setup adjustments; improper maintenance, alteration, improper use of any input signal; damage due to lightning or power line surges, spikes and brownouts; damage that occurs during shipping or transit; or damage that is attributed to acts of God. In the case of remote control units, damage resulting from leaking, old, damaged or improper batteries is also excluded from coverage under this Limited Warranty.

CAUTION: THIS LIMITED WARRANTY ONLY COVERS VIDIKRON PRODUCTS PURCHASED FROM VIDIKRON AUTHORIZED DEALERS. ALL OTHER PRODUCTS ARE SPECIFICALLY EXCLUDED FROM COVERAGE UNDER THIS WARRANTY. MOREOVER, DAMAGE RESULTING DIRECTLY OR INDIRECTLY FROM IMPROPER INSTALLATION OR SETUP IS SPECIFICALLY EXCLUDED FROM COVERAGE UNDER THIS LIMITED WARRANTY. IT IS IMPERATIVE THAT INSTALLATION AND SETUP WORK BE PERFORMED ONLY BY AN AUTHORIZED VIDIKRON DEALER TO PROTECT YOUR RIGHTS UNDER THIS WARRANTY. THIS WILL ALSO ENSURE THAT YOU ENJOY THE FINE PERFORMANCE OF WHICH YOUR VIDIKRON PRODUCT IS CAPABLE WHEN INSTALLED AND CALIBRATED BY VIDIKRON AUTHORIZED PERSONNEL.

RIGHTS, LIMITS AND EXCLUSIONS:

Vidikron limits its obligations under any implied warranties under state laws to a period not to exceed the warranty period. There are no express warranties. Vidikron also excludes any obligation on its part for incidental or consequential damages related to the failure of this product to function properly. Some states do not allow limitations on how long an implied warranty lasts, and some states do not allow the exclusion or limitation of incidental or consequential damages. So the above limitations or exclusions may not apply to you. This warranty gives you specific legal rights, and you may also have other rights that vary from state to state.

EFFECTIVE WARRANTY DATE:

This warranty begins on the effective date of delivery to the end user. For your convenience, keep the original bill of sale as evidence of the purchase date.

IMPORTANT -- WARRANTY REGISTRATION:

Please fill out and mail your warranty registration card. It is imperative that Vidikron knows how to reach you promptly if we should discover a safety problem or product update for which you must be notified.

CONTACT A VIDIKRON AUTHORIZED SERVICE CENTER TO OBTAIN SERVICE:

Repairs made under the terms of this Limited Warranty covering your Vidikron video product will be performed at the location of the product, during usual working hours, providing location of product is within normal operating distance from a Vidikron Authorized Service Center. In some instances it may be necessary for the product to be returned to the Vidikron factory for repairs. If, solely in Vidikron's judgment, location of product to be repaired is beyond normal operating distance of the closest Vidikron Authorized Service Center, or the repair requires the unit be returned to the Vidikron factory, it is the owner's responsibility to arrange for shipment of the product for repair. These arrangements must be made through the selling Vidikron Dealer. If this is not possible, contact Vidikron directly for a Return Authorization number and shipping instructions. Vidikron will return product transportation prepaid in the United States, unless no product defect is discovered. In that instance, shipping costs will be the responsibility of the owner.

COPYRIGHT AND TRADEMARKS:

© Copyright 2007 Vidikron, a Runco International Company. This document contains proprietary information protected by copyright, trademark and other intellectual property laws. All rights are reserved. No part of this manual may be reproduced by any mechanical, electronic or other means, in any form, without prior written permission of the manufacturer.

Vidikron, Vision, DVSI, Imagix, CineWide, AutoScope, V² Aperture Control, CSMS and IntelliWide are trademarks of Runco, LLC. All other trademarks and registered trademarks used in this document are the property of their respective owners.

THX and the THX logo are trademarks of THX Ltd. which may be registered in some jurisdictions. All rights reserved.

Vidikron products are manufactured under one or more of the following patents: US. Patent 6755540 and Other Patents Pending.

ADDITIONAL INFORMATION:

To locate the name and address of the nearest Vidikron Authorized Service Center, or for additional information about this Limited Warranty, please call or write:

VIDIKRON
Attn: Customer Service Department
2900 Faber Street
Union City, CA 94587
Ph: (510) 324-5900
Fax: (510) 324-5905
Toll Free: (888) 4VIDIKRON

VIDIKRON PRODUCT INFORMATION
RETAIN THIS INFORMATION FOR YOUR RECORDS

Model Purchased

Date

Serial Number

Vidikron Authorized Dealer Name

Address

City

State/Province

Postal Code

Phone

Fax

Important Safety Instructions

Thank you for your purchase of this quality Vidikron video projector! It has been designed to provide you with the quality of video that is expected in a home theater. For the best performance, please read this manual carefully as it is your guide through the menus and operation.

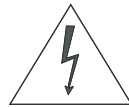
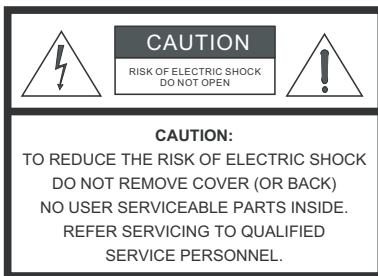

WARNING

This symbol is intended to alert the user to the presence of uninsulated “dangerous voltage” within the product’s enclosure that may be of sufficient magnitude to constitute a risk of electric shock.



This symbol is intended to alert the user to the presence of important operating and maintenance (servicing) instructions in the literature accompanying the appliance.

1. Read these instructions.
2. Keep these instructions.
3. Heed all warnings.
4. Follow all instructions.
5. Do not use this apparatus near water.
6. Clean only with a dry cloth.
7. Do not block any of the ventilation openings. Install in accordance with the manufacturer’s instructions.
8. Do not install near any heat sources such as radiators, heat registers, stoves, or other apparatus (including amplifiers) that produce heat.
9. Do not defeat the safety purpose of the polarized or grounding type plug. A polarized plug has two blades with one wider than the other. A grounding type plug has two blades and a third grounding prong. The wide blade or the third prong is provided for your safety. When the provided plug does not fit into your outlet, consult an electrician for the replacement of the obsolete outlet.
10. Protect the power cord from being walked on or pinched particularly at plugs, convenience receptacles and the point where they exit from the apparatus.
11. Only use the attachments/accessories specified by Vidikron.
12. Use only with a cart, stand, tripod, bracket or table specified by the manufacturer or sold with the apparatus. When a cart is used, use caution when moving the cart/apparatus to avoid injury from tip-over.
13. Unplug this apparatus during lightning storms or when unused for long periods of time.
14. Refer all servicing to qualified service personnel. Servicing is required when the apparatus has been damaged in any way, such as power supply cord or plug is damaged, liquid has been spilled or objects have fallen into the apparatus, the apparatus has been exposed to rain or moisture, does not operate normally, or has been dropped.
15. The +12V trigger only outputs 12Vdc signal for triggering. Do not connect to any other power input or output. This could cause damage to this unit.
16. Keep the packing material in case the equipment should ever need to be shipped.
17. The lamp becomes extremely hot during operation. Allow the projector to cool down for approximately 45 minutes prior to removing the lamp assembly for replacement. Do not operate lamps beyond the rated lamp life. Excessive operation of lamps beyond rated life could cause them to explode in rare occasions.



Compliance Information

DECLARATION OF CONFORMITY:

Manufacturer's Name: Vidikron, a subsidiary of Planar Systems, Inc.

Manufacturer's Address: 2900 Faber Street, Union City, CA 94587

hereby declares that the products Model Numbers:

Vision 120, Vision 120/CineWide and Vision 120/CineWide with AutoScope

conform with the provisions of:

Council Directive 2004/108/EC on Electromagnetic Compatibility;

EN 55022 "Limits and methods of measurements of radio interference characteristics of information technology equipment" 1998;

EN 55024 "Limits and methods of measurements of immunity characteristics of information technology equipment" 1998;

Including:

- EN 61000-4-2 "Electromagnetic compatibility (EMC) Part 4: Testing and measurement techniques Section 2: Electrostatic discharge immunity test"
- EN 61000-4-3 "Electromagnetic compatibility (EMC) Part 4: Testing and measurement techniques Section 3: Radiated, Radio-Frequency, Electromagnetic Field Immunity Test"
- EN 61000-4-4 "Electromagnetic compatibility (EMC) Part 4: Testing and measurement techniques Section 4: Electrical fast transient/burst immunity test"
- EN 61000-4-5 "Electromagnetic compatibility (EMC) Part 4: Testing and measurement techniques Section 5: Surge immunity test"
- EN 61000-4-6 "Electromagnetic compatibility (EMC) Part 4: Testing and measurement techniques Section 6: Conducted disturbances induced by radio-frequency fields immunity test"
- EN 61000-4-8 "Electromagnetic compatibility (EMC) Part 4: Testing and measurement techniques Section 8: Conducted disturbances induced by power frequency magnetic fields immunity test"
- EN 61000-4-11 "Electromagnetic compatibility (EMC) Part 4: Testing and measurement techniques Section 11: Voltage dips, short interruptions and voltage variations immunity tests"

And:

- EN 61000-3-2 "Electromagnetic compatibility (EMC) Part 3, Section 2: Limits for harmonic current emissions (equipment input current up to and including 16 A per phase)" 2000;
- EN 61000-3-3 "Electromagnetic compatibility (EMC) Part 3, Section 3: Limitations of voltage changes, voltage fluctuations and flicker in public low-voltage supply systems, for equipment with rated current up to and including 16 A and not subject to conditional connection" 1995;

Council Directive 2006/95/EC and amended by M1 and C1 on Low Voltage Equipment Safety;

EN 60950 "Safety of information technology equipment, including electrical business equipment"

The Technical Construction file required by this Directive is maintained at the corporate headquarters of Planar Systems, Inc., 1195 NW Compton Drive, Beaverton, OR 97006.

Date of Declaration: December 2007

FCC PART 15:

NOTE: This equipment has been tested and found to comply with the limits for a Class B digital device, pursuant to Part 15 of the FCC Rules. These limits are designed to provide reasonable protection against harmful interference in a residential installation.

This equipment generates, uses and can radiate radio frequency energy and, if not installed and used in accordance with the instructions, may cause harmful interference to radio communications. However, there is no guarantee that interference will not occur in a particular installation. If this equipment does cause harmful interference to radio or television reception, which can be determined by turning the equipment off and on, the user is encouraged to try to correct the interference by one or more of the following measures:

- Reorient or relocate the receiving antenna.
- Increase the separation between the equipment and receiver.
- Connect the equipment into an outlet on a circuit different from that to which the receiver is connected.
- Consult the dealer or an experienced radio/TV technician for help.

INDUSTRY CANADA (ICES-003):

This Class B digital apparatus complies with Canadian ICES-003.

Cet appareil numérique de la classe B est conforme à la norme NMB-003 du Canada.

IMPORTANT RECYCLE INSTRUCTIONS



Lamp(s) inside this product contain mercury. This product may contain other electronic waste that can be hazardous if not disposed of properly. Recycle or dispose in accordance with local, state, or federal Laws.

For more information, contact the Electronic Industries Alliance at WWW.EIAE.ORG.

For lamp specific disposal information check WWW.LAMPRECYCLE.ORG.

DISPOSAL OF OLD ELECTRICAL AND ELECTRONIC EQUIPMENT (Applicable throughout the European Union and other European countries with separate collection programs)



This symbol found on your product or on its packaging, indicates that this product should not be treated as household waste when you wish to dispose of it. Instead, it should be handed over to an applicable collection point for the recycling of electrical and electronic equipment. By ensuring this product is disposed of correctly, you will help prevent potential negative consequences to the environment and human health, which could otherwise be caused by inappropriate disposal of this product. The recycling of materials will help to conserve natural resources. This symbol is only valid in the European Union. If you wish to discard this product, please contact your local authorities or dealer and ask for the correct method of disposal.

Table of Contents

| | |
|--|------------|
| TWO YEAR LIMITED WARRANTY | iii |
| Important Safety Instructions | vi |
| Compliance Information | vii |
| 1. Introduction | 1 |
| About This Manual | 1 |
| Target Audience..... | 1 |
| If You Have Comments About This Manual..... | 1 |
| Textual and Graphic Conventions | 1 |
| Using This Manual | 2 |
| Description, Features and Benefits | 3 |
| Key Features and Benefits..... | 3 |
| Parts List | 4 |
| 2. Controls and Functions | 5 |
| Vision 120 at a Glance | 5 |
| Vision 120 Rear Panel | 6 |
| VHD Controller Front Panel | 8 |
| VHD Controller Rear Panel | 10 |
| Vision 120 Remote Control | 12 |
| 3. Installation | 15 |
| Remote Control | 15 |
| Notes on Batteries | 15 |
| Notes on Remote Control Operation..... | 15 |
| Quick Setup | 16 |
| Installation Considerations | 17 |
| Installation Type..... | 17 |
| Ambient Light | 17 |
| Throw Distance..... | 18 |
| Vertical and Horizontal Position | 19 |
| Vertical and Horizontal Lens Shift..... | 19 |
| Folded Optics | 21 |
| Other Considerations | 22 |
| Installing the Primary Projection Lens | 22 |

| | |
|---|-----------|
| Installing the Optional CineWide Lens Mount | 24 |
| Installing the AutoScope Lens Motor (Vision 120/CineWide with AutoScope) | 25 |
| Installing the Fixed CineWide Base Plate (Vision 120/CineWide) | 29 |
| Mounting the Vision 120 | 30 |
| Floor Mounting (Upright) | 30 |
| Ceiling Mounting (Inverted) | 30 |
| Adjusting the Projection Angle | 30 |
| Connections to the Vision 120 and VHD Controller | 31 |
| Connector Panel Access | 31 |
| Connecting the VHD Controller to the Vision 120..... | 31 |
| Connecting Source Components to the VHD Controller | 32 |
| RS-232 Controller Connection | 37 |
| Connecting 12-Volt Trigger Outputs to External Theater Equipment | 38 |
| Connecting an External IR Receiver to the VHD Controller | 39 |
| Connecting to AC Power..... | 40 |
| Turning on the Power | 40 |
| Adjusting the Picture Orientation | 40 |
| Primary Lens Adjustments | 41 |
| Focus | 41 |
| Zoom | 41 |
| Vertical and Horizontal Lens Shift..... | 41 |
| Installing and Adjusting the CineWide Anamorphic Lens | 42 |
| Attach Lens Mounting Assembly to Lens Motor Carriage Plate (CineWide with AutoScope) or Base Plate (fixed CineWide)..... | 42 |
| Configure Lens Motor Trigger..... | 44 |
| Adjust the Anamorphic Lens..... | 44 |
| 4. Operation | 49 |
| Using the On-Screen Menus | 49 |
| Main Menu | 51 |
| Input Source | 51 |
| Aspect Ratio..... | 51 |
| Picture | 53 |
| Input Position..... | 57 |
| Memory Presets..... | 58 |
| Information | 58 |
| Calibration..... | 59 |
| Service..... | 61 |

| | |
|---|-----------|
| 5. Maintenance and Troubleshooting | 63 |
| Lamp Replacement | 63 |
| Filter Replacement | 64 |
| Troubleshooting Tips | 65 |
| 6. Serial Communications | 67 |
| RS-232 Connection and Port Configuration | 67 |
| Serial Command Syntax | 67 |
| 7. Specifications | 71 |
| Vision 120 Specifications | 71 |
| VHD Controller Specifications | 73 |
| Vision 120 Dimensions | 74 |
| Supported Timings | 75 |

Notes:

List of Figures

| | |
|--|----|
| 2-1. Vision 120 Front/Bottom/Side View..... | 5 |
| 2-2. Vision 120 Rear Panel | 6 |
| 2-3. VHD Controller Front Panel | 8 |
| 2-4. VHD Controller Rear Panel | 10 |
| 2-5. Vision 120 Remote Control..... | 12 |
| 3-1. Estimating Throw Distance..... | 18 |
| 3-2. Projector Placement | 19 |
| 3-3. Vertical Lens Shift (EXAMPLE ONLY) | 19 |
| 3-4. Horizontal Lens Shift (EXAMPLE ONLY) | 20 |
| 3-5. Folded Optics..... | 21 |
| 3-6. Vision 120/CineWide with AutoScope Motor Assembly - Exploded View | 25 |
| 3-7. Vision 120 with Ceiling Mount Adapters/Projector Stands | 27 |
| 3-8. AutoScope Lens Motor Installation | 28 |
| 3-9. Installing the Fixed CineWide Base Plate..... | 29 |
| 3-10. Connecting the Vision 120 to the VHD Controller | 31 |
| 3-11. HDMI Source Connections | 32 |
| 3-12. Digital (DTV) RGB or Component Video Connections (HD1, HD2) | 33 |
| 3-13. Digital (DTV) RGB or Component Video Connections (HD3) | 34 |
| 3-14. Analog RGB Connections | 35 |
| 3-15. S-Video and Composite Video Connections | 36 |
| 3-16. RS-232 Control System Connection | 37 |
| 3-17. 12-volt Trigger Output Connections..... | 38 |
| 3-18. External IR Receiver Connection..... | 39 |
| 3-19. Vision 120 Anamorphic Lens Mounting Assembly - Exploded View | 42 |
| 3-20. Attaching the Anamorphic Lens to the Lens Adapter Ring | 43 |
| 4-1. VHD Controller OSD Menu Structure for Vision 120 | 50 |
| 4-2. Typical PLUGE Pattern for Adjusting Brightness..... | 54 |
| 4-3. Typical Gray Bar Pattern for Adjusting Contrast | 55 |
| 4-4. Typical Color Bar Pattern for Adjusting Color Saturation and Tint | 55 |
| 4-5. Typical Test Pattern for Adjusting Sharpness..... | 57 |
| 7-1. Vision 120/CineWide with AutoScope Dimensions | 74 |

Notes:

Introduction

This Owner's Manual describes how to install, set up and operate the Vidikron Vision Model 120 DLP Projector and VHD Controller. Throughout this manual, the Vidikron Vision Model 120 DLP Projector and VHD Controller are referred to collectively as the "Vision 120."

Vidikron has prepared this manual to help home theater installers and end users get the most out of the Vision 120.

Vidikron has made every effort to ensure that this manual is accurate as of the date it was printed. However, because of ongoing product improvements and customer feedback, it may require updating from time to time. You can always find the latest version of this and other Vidikron product manuals on-line, at www.Vidikron.com.

Vidikron welcomes your comments about this manual. Send them to info@Vidikron.com.

Text Conventions: The following conventions are used in this manual, in order to clarify the information and instructions provided:

- Remote and built-in keypad button identifiers are set in upper-case bold type; for example, "Press **EXIT** to return to the previous menu."
- Computer input (commands you type) and output (responses that appear on-screen) is shown in monospace (fixed-width) type; for example: "To change the aspect ratio to Letterbox, type `SAR 2<Enter>`."
- All keys with functional names are initial-capped, set in bold type and enclosed in angle brackets. These keys are the following: `<Enter>`, `<Spacebar>`, `<Control>`, `<Esc>` and `<Tab>`.
- `<Enter>` indicates that you may press either the RETURN or ENTER key on your keyboard if it has both keys.

In addition to these conventions, underlining, boldface and/or italics are occasionally used to highlight important information, as in this example:



Note

*A carriage return **must** be used after each command or string.*

1.1 About This Manual

◀ Target Audience

◀ If You Have Comments About This Manual...

◀ Textual and Graphic Conventions

Graphic Conventions: These symbols appear in numerous places throughout the manual, to emphasize points that you must keep in mind to avoid problems with your equipment or injury:



Tip

TIPS highlight time-saving short cuts and helpful guidelines for using certain features.



Note

NOTES emphasize text with unusual importance or special significance. They also provide supplemental information.



Caution

CAUTIONS alert users that a given action or omitted action can degrade performance or cause a malfunction.



WARNING

WARNINGS appear when a given action or omitted action can result in damage to the equipment, or possible non-fatal injury to the user.



DANGER!

DANGER appears when a given action can cause severe injury or death.

1.2 Using This Manual

Use the following table to locate the specific information you need in this manual.

| If you need... | ... Turn to page: |
|---|--------------------------|
| Information about obtaining service | iv |
| General information about the Vision Model 120 DLP Projector and VHD Controller | 3 |
| Installation instructions | 15 |
| First-time configuration instructions | 49 |
| Advanced configuration instructions | 59 |
| Troubleshooting tips | 65 |
| Product specifications | 71 |

Vidikron further solidifies its leadership role with the introduction of the Vision 120 Digital Light Processing (DLP™) Projector. This overachiever combines state-of-the-art, 1920x1080 DLP™ resolution with advanced 3-chip engineering. The results are simply stunning, with jaw-dropping images that must be seen to be believed!

Vidikron has taken 1080p performance to a new level with this machine and harnessed the brightness and contrast capabilities inherent in 3-chip light engine design for a powerful presentation.

The Vision 120 comes with an external, all-digital signal processor/controller featuring advanced Imagix™ video processing, superb scaling and aspect ratio control. The Vision 120 is enhanced further by significant horizontal and vertical lens shift capability for maximum installation flexibility.

The Vision 120's 16:9 native aspect ratio DMD array makes it ideal for widescreen viewing, while its 3-chip, 1920 x 1080 native resolution produces crisp, crystal clear high-definition images with richly saturated colors, deep black levels and natural, highly refined detail.

This advanced design provides pure digital connections from input to light engine for absolutely stellar pictures. In addition, Vidikron's multiple aspect ratio control includes its unique IntelliWide™ mode for viewing standard video formats in widescreen without loss of image quality.

For uncompromising widescreen reproduction of movies originally filmed in the "scope" (2.35:1) format, the Vision 120 can be equipped with Vidikron's patent-pending CineWide™ technology, a combination of software, electronics and high-quality anamorphic optics. CineWide maintains constant vertical height on the screen just as in a movie theater. When a viewer transitions from 1.78:1 (16:9) program material to 2.35:1, the image simply gets wider while full height is maintained. Also available with the Vision 120 is CineWide with AutoScope™, an enhanced, remote-controlled motorized version of CineWide.



Note

CineWide requires the use of a 2.35:1 or similar aspect ratio superwide format screen.

Discrete IR and RS-232 control make custom installation seamless, while discrete source and aspect ratio selection accommodate any automation control system.

The Vision 120 offers these key features and benefits:

- Native Resolution: 1920 x 1080 (16:9 Native Aspect Ratio)
- Three-chip Digital Light Processing (DLP™) system
- Two HDMI Inputs (on VHD Controller) with High-bandwidth Digital Content Protection (HDCP)
- HDTV Compatible
- Multiple lens options for stunning sharpness and throw distance flexibility

1.3 Description, Features and Benefits

◀ Key Features and Benefits

Parts List ➤ Your Vision 120 is shipped with the following items. If any items are missing or damaged, please contact your Vidikron dealer or Vidikron Customer Service at (888) 4VIDIKRON.

- Vision Model 120 DLP Projector and VHD Controller
- Remote Control Unit and two (2), AAA-size batteries
- AC Power Cords for Projector and VHD Controller
- Rack-mount hardware for the VHD Controller
- Warranty information and registration card
- Vidikron Vision Model 120 Installation/Operation Manual (this document)

Optional Accessories:

- Dual-Link DVI Cable, length specified at time of order; available lengths range from 7.5 meters to 20 meters (24.6 feet to 65.6 feet)
- CineWide™ technology (fixed, secondary anamorphic lens)
- CineWide™ with AutoScope™ system (secondary anamorphic lens and motorized mount)
- Ceiling mount kit (part number 956-0247-00)
- Cool-cube™ Exhaust Kit
- Communications Adapter, Dual-Link DVI male to DVI-D female and RJ-11 female, pair (part number 146-0012-00)

2. Controls and Functions

Figure 2-1 shows the key Vision 120 components.

2.1 Vision 120 at a Glance

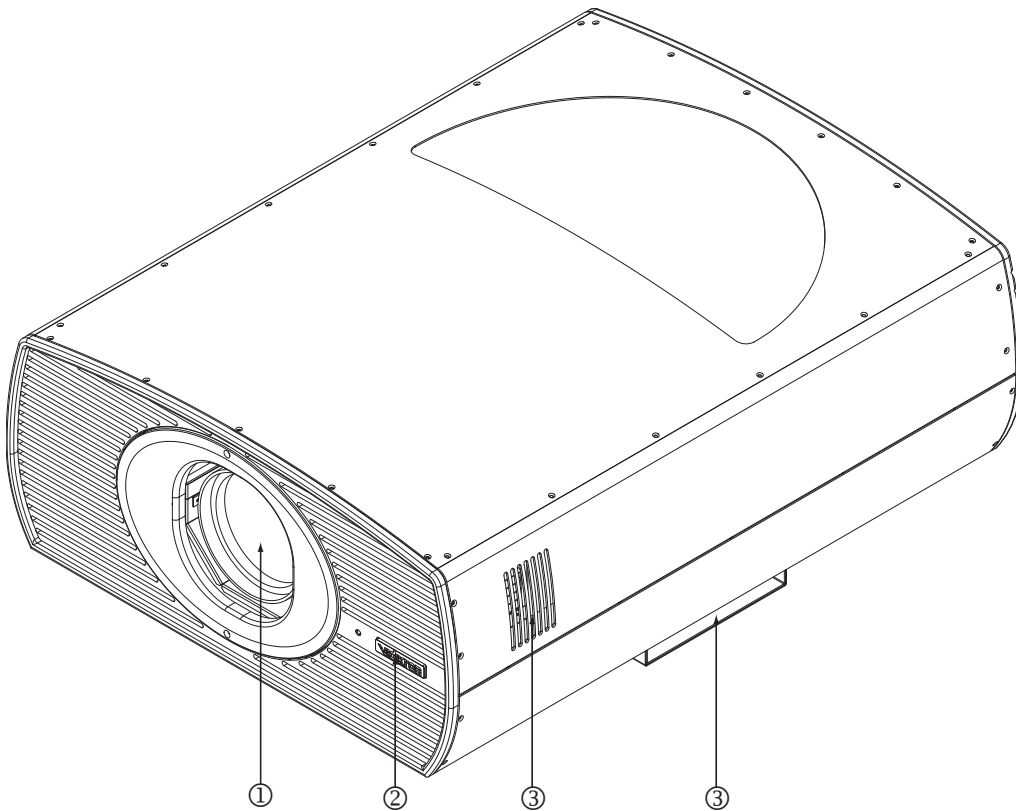

Figure 2-1. Vision 120 Front/Bottom/Side View

1. **PRIMARY PROJECTION LENS**
2. **VIDIKRON LOGO**
The logo can be rotated to match the projector orientation: inverted (ceiling-mounted) or upright. To rotate the logo, grip it at the sides, pull it away from the projector and rotate it 180 degrees.
3. **EXHAUST VENTS**

2.2 Vision 120 Rear Panel

Figure 2-2 shows the Vision 120 rear panel.

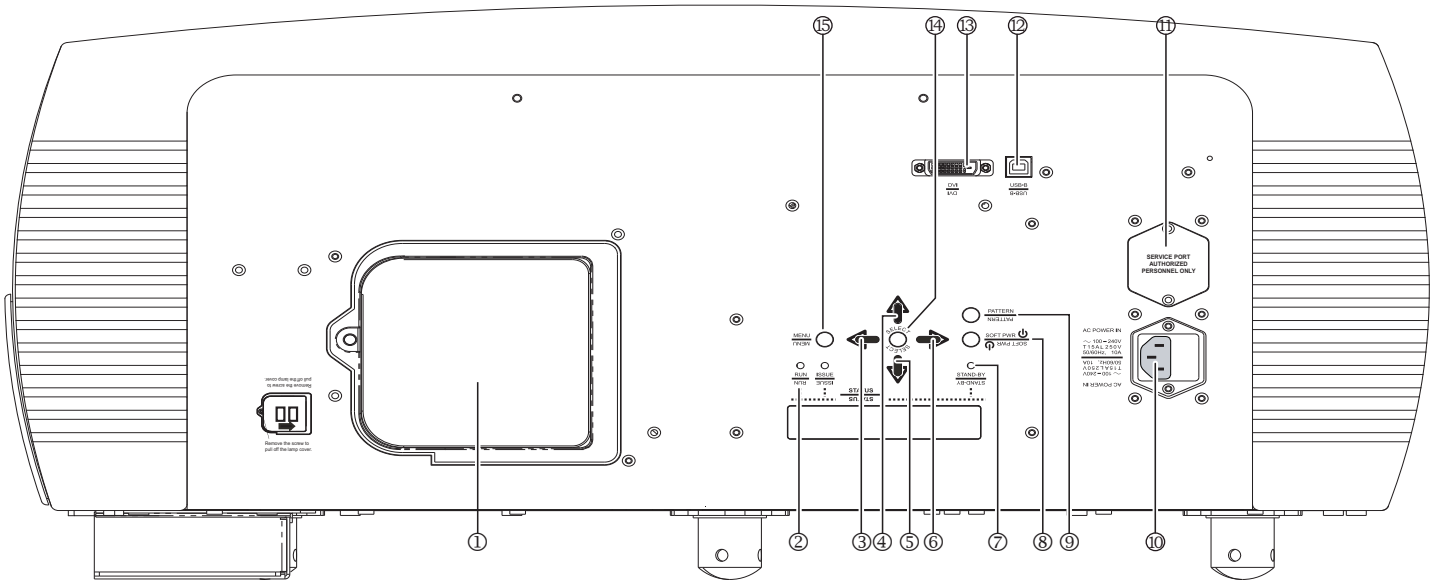

Figure 2-2. Vision 120 Rear Panel

1. **LAMP COVER**
Remove this cover to access the lamp compartment.
2. **RUN LED**
Lights blue to indicate that the projector is functioning normally.
3. **LEFT BUTTON**
Used to move the menu cursor left in the Vision 120 menu system.
4. **UP BUTTON**
Used to move the menu cursor up in the Vision 120 menu system.
5. **DOWN BUTTON**
Used to move the menu cursor down in the Vision 120 menu system.
6. **RIGHT BUTTON**
Used to move the menu cursor right in the Vision 120 menu system.
7. **STAND-BY LED**
Lights orange to indicate that the projector is in standby mode.
8. **SOFT POWER BUTTON**
Press once to turn on the Vision 120. Press it again to put the projector into Standby mode. For a discrete on or off command, you can use the direct access buttons on the remote control (see Figure 2-5).
9. **PATTERN BUTTON**
Press **PATTERN** to access the internal test pattern menu. Use arrow keys to select a pattern and press **SELECT** to confirm. Press **PATTERN** again to return to the selected source.

10. **POWER INPUT (100 to 240 VAC)**

Connect the Vision 120 to power here.

11. **SERVICE PORT**

For use by authorized service personnel only.

12. **USB-B**

High-speed service port (for future use).

13. **DVI-DL (Dual-Link)**

An HDCP-compliant, dual-link digital video input for connecting the output from the VHD Controller.

14. **SELECT BUTTON**

Press **SELECT** to confirm your selection of a highlighted choice on the On-Screen Display (OSD).

15. **MENU BUTTON**

Pressing the **MENU** button brings up the main Vision 120 menu. Also, if you are in an adjustment mode or function, pressing **MENU** brings the menu back one level.

2.3 VHD Controller Front Panel

Figure 2-3 shows the controls and indicators on the VHD Controller front panel; the paragraphs that follow describe them.

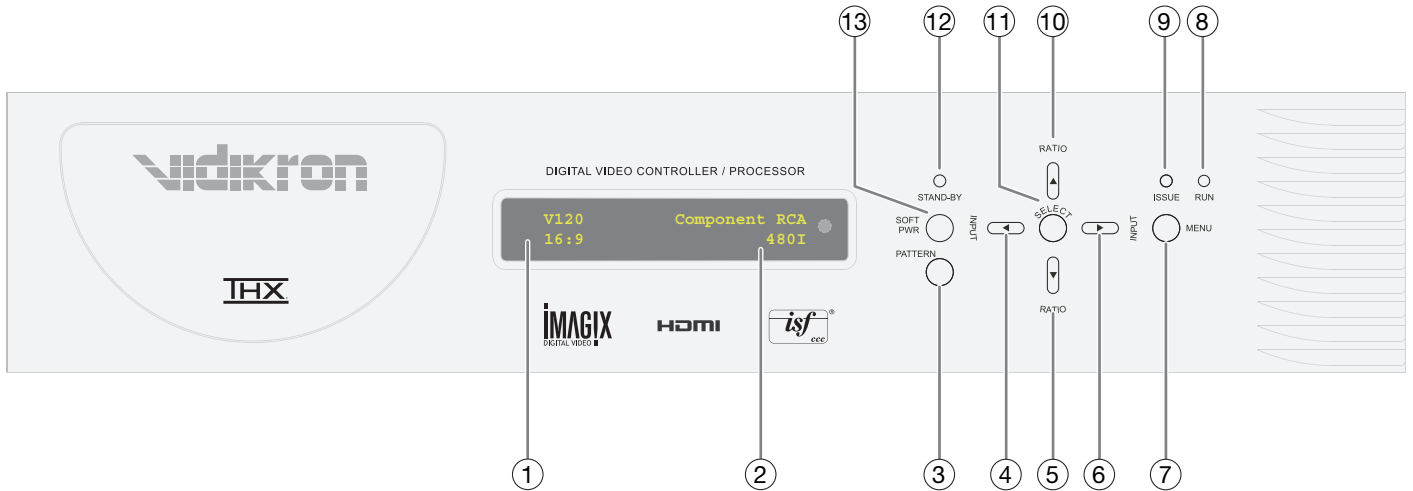

Figure 2-3. VHD Controller Front Panel

1. **IR SENSOR**
Receives IR commands from the remote.
2. **VACUUM FLUORESCENT DISPLAY (VFD)**
Can be used instead of the OSD. Displays currently-selected menu or – if no menu is selected – the current source, input resolution and aspect ratio.

If an error condition occurs, a message appears here indicating the cause:

Please check issue(s)
Communication Error
3. **PATTERN BUTTON**
Press **PATTERN** to access the internal test pattern menu. Use arrow keys to select a pattern and press **SELECT** to confirm. Press **PATTERN** again to return to the selected source.
4. **LEFT BUTTON**
Used to direct-select inputs or move the menu cursor left in the OSD. When no menu is present on-screen, the **LEFT** button toggles through the different sources, in this order: HDMI 2 - HDMI 1 - HD3 (VGA/Y-Pb-Pr) - HD 2 (BNC) - HD 1 (RCA) - S-Video - Composite (VID)
5. **DOWN BUTTON**
Use to direct-select aspect ratios or move the menu cursor down in the OSD. When no menu is present on-screen, the **DOWN** button toggles through the different aspect ratios, in this order:
IntelliWide 2.35 - Cinema - IntelliWide - Letterbox - 4:3 - 16:9

6. RIGHT BUTTON

Used to direct-select inputs or move the menu cursor right in the OSD. When no menu is present on-screen, the **RIGHT** button toggles through the different sources, in this order: Composite (VID) - S-Video - HD 1 (RCA) - HD 2 (BNC) - HD 3 (VGA/Y-Pb-Pr) - HDMI 1 - HDMI 2

7. MENU BUTTON

Pressing the **MENU** button brings up the main menu. Also, if you are in an adjustment mode or function, pressing **MENU** brings the menu back one level.

8. RUN LED

- Lights blue to indicate that the projector is functioning normally.
- Flashes blue (one second on/one second off) to indicate an error condition.
- Flashes blue (one half-second on/one half-second off) for approximately 90 seconds after the system is turned off.

9. ISSUE LED

Lights red to indicate an error condition.

10. UP BUTTON

Use to direct-select aspect ratios or move the menu cursor up in the OSD. When no menu is present on-screen, the **UP** button toggles through aspect ratios in the following order:

16:9 - 4:3 - Letterbox - IntelliWide - Cinema - IntelliWide 2.35

(IntelliWide 2.35 is available only on CineWide-equipped projectors. For more information about aspect ratios, refer to Table 4-1.)

11. SELECT BUTTON

Press **SELECT** to confirm your selection of a highlighted choice on the OSD.

12. STAND-BY LED

Lights orange to indicate that the projector is in standby mode.

13. SOFT POWER BUTTON

Press once to turn on the Vision 120. Press it again to put the projector into Standby mode. For a discrete on or off command, you can use the direct access buttons on the remote control (see Figure 2-5).

2.4 VHD Controller Rear Panel

Figure 2-4 shows the rear connector panel on the VHD Controller.

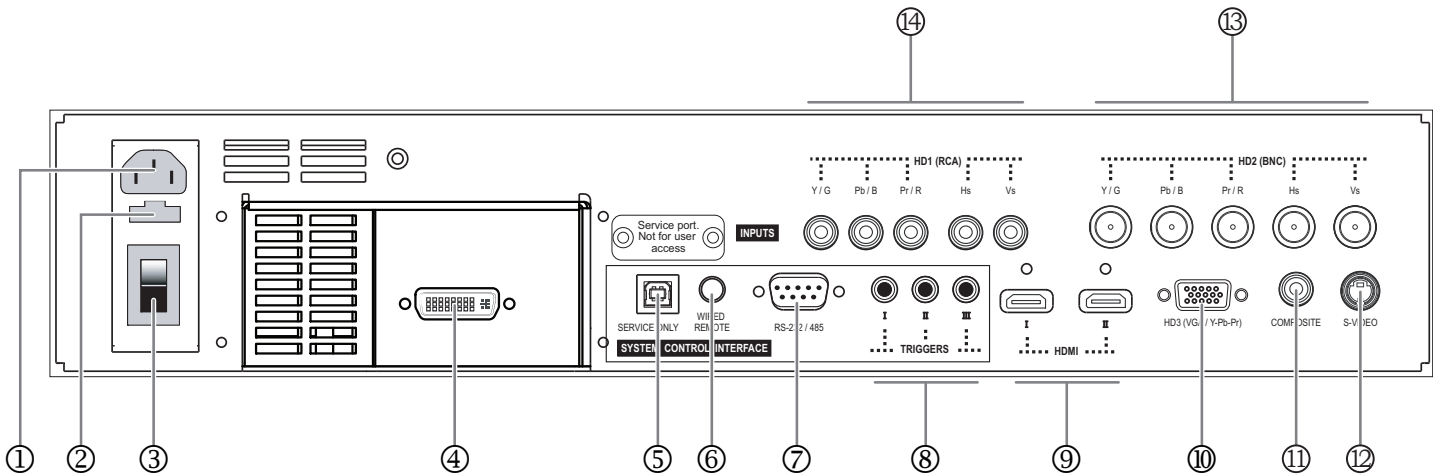

Figure 2-4. VHD Controller Rear Panel

1. **POWER INPUT (100 to 240 VAC)**
Connect the VHD Controller to power here.
2. **MAIN AC FUSE**
This is the main AC input fuse (5mm x 20mm, 500 mA, 250V slow-blow).
3. **MAIN POWER SWITCH**
Disconnects or applies power to the VHD Controller.
4. **DVI-DL (DUAL-LINK) OUTPUT (1080p)**
Connect this to the VHD Input at the rear of the Vision 120 (see Figure 2-2).
5. **SERVICE ONLY**
For future use.
6. **WIRED REMOTE**
Wired input from an external remote control or infrared receiver. It is a 3.5-mm, mini phono jack, wired as follows:
Ring = +5V
Tip = IR Input (TTL level)
Sleeve = Ground



Note

When an external remote control or infrared receiver is connected to the wired IR input, the IR sensor on the front of the VHD Controller is disabled.

7. **RS-232/485 CONTROL PORT**
A male, 9-pin D-sub connector for interfacing with a PC or home theater automation/control system. (Currently, only RS-232 interface is supported.)
8. **12-VOLT (750 mA) TRIGGER OUTPUTS**
Connection for up to three (3), 12-volt trigger-controlled devices. These can be retractable screens, screen masks or the Vidikron CineWide with AutoScope system.

9. **HDMI I (1) / HDMI II (2) (Digital)**

Two, HDCP-compliant digital video inputs for connecting a DVD player, HD tuner or other digital video source (up to 1080p) with a DVI or HDMI output.

10. **HD3 INPUT**

Provides a standard, 15-pin VGA-style connection to either an RGB or component high-definition source, or to a personal computer. The VHD Controller automatically detects the input signal resolution.

11. **COMPOSITE VIDEO INPUT**

Standard composite video input for connecting a VCR, laser disc player or other composite video source.

12. **S-VIDEO INPUT**

A standard S-Video input for connecting a DVD player, satellite receiver or Super VHS (S-VHS) VCR.

13. **HD2 INPUT**

Five BNCs for connecting either RGB or component high-definition sources (up to 1080p). The VHD Controller automatically detects the input signal resolution.

14. **HD1 INPUT**

Five RCA-type connectors for either RGB or component high-definition sources (up to 1080p). The VHD Controller automatically detects the input signal resolution.



Tip

For best results, do not run your DVD player in progressive mode.

2.5 Vision 120 Remote Control

Figure 2-5 shows the Vision 120 remote control, and the paragraphs that follow describe its functionality.

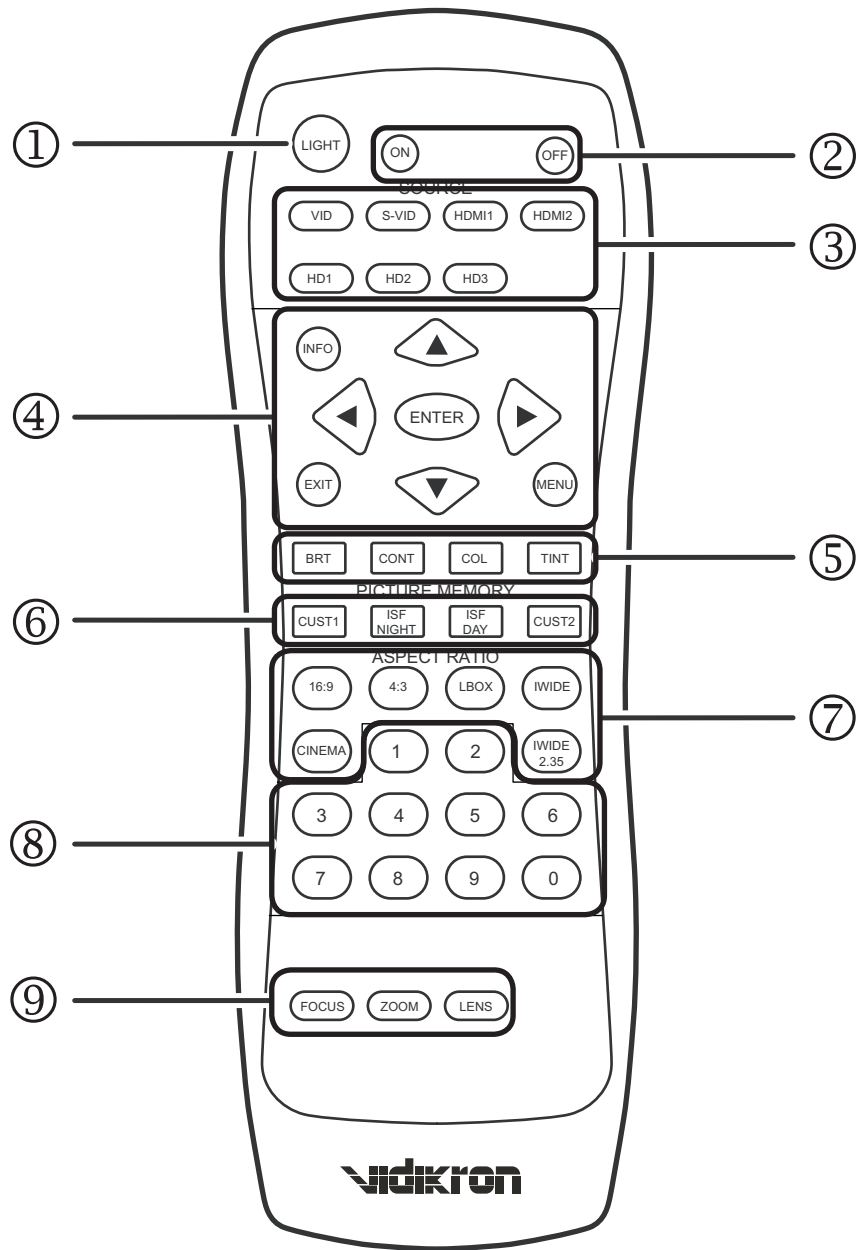

Figure 2-5. Vision 120 Remote Control

1. LIGHT

Press to illuminate the buttons.

2. ON / OFF

Use these buttons to turn the projector on or off.

3. Source Selection Buttons:**VID**

Press to select Composite video input as the source.

S-VID (S-Video)

Press to select the S-Video input as the source.

HDMI 1 (I) / HDMI 2 (II)

Press to select an HDMI input.

HD 1 / HD 2 / HD 3

Press to select the HD 1 (RCA), HD 2 (BNC) or HD 3 (PC) video input as the source.

4. INFO

Press to display input signal and product information.

Cursor Keys (▲, ◀, ▼, ▶)

Use these buttons to select items or settings, adjust settings or switch display patterns.

EXIT

Press to save menu item setting(s), exit the current menu and return to the previous one.

ENTER

Press to select a highlighted menu item or confirm a changed setting. This button functions similarly to the **SELECT** button on the projector rear panel (Figure 2-2) or VHD Controller front panel (Figure 2-3).

MENU

Press this button to show or hide the OSD controls.

5. Picture Adjustment Buttons:**BRT (Brightness)**

Press to adjust black level.

CONT (Contrast)

Press to adjust white level.

COL (Color)

Press to adjust color intensity.

TNT (Tint)

Press to adjust color hues.

6. **Memory Preset Buttons:**

CUST1

Press to recall settings for the current input from the "Custom 1" memory preset.

ISF NIGHT

Press to recall settings for the current input from the "ISF Night" memory preset.

ISF DAY

Press to recall settings for the current input from the "ISF Day" memory preset.

CUST2 (THX)

Press to recall settings for the current input from the "THX" memory preset.

7. **Aspect Ratio Selection Buttons**

Use these buttons to select an aspect ratio directly, as follows:

16:9

For viewing 16:9 DVDs or HDTV programs in their native aspect ratio.

4:3

Scales the input signal to fit 4:3 display mode in the center of the screen.

LBOX (Letterbox)

For viewing LaserDisc movies or non-anamorphic DVDs on a 16:9 screen.

IWIDE (IntelliWide)

Enlarges a 4:3 image horizontally in a NON-linear fashion to fit 16:9 full screen display.

CINEMA

For viewing 2.35:1 source material.

IWIDE 2.35 (IntelliWide 2.35 – CineWide-equipped projectors only)

Selects the IntelliWide 2.35 aspect ratio, used for viewing 16:9 source material on a 2.35:1 screen.

8. **0 - 9**

Use these keys to enter numeric characters.

9. **Motorized Lens Controls:**

FOCUS

To focus the image, press **FOCUS**. Then, press and hold the **UP** or **DOWN** button. When finished, press **MENU** or **EXIT**.

ZOOM

To adjust the projected image size, press **ZOOM**. Then, press and hold the **UP** button to zoom in (enlarge) or the **DOWN** button to zoom out (reduce). When finished, press **MENU** or **EXIT**.

LENS (Lens Shift)

To adjust the lens position, press **LENS**. Then, press and hold the **RIGHT, LEFT, UP** or **DOWN** button. When finished, press **MENU** or **EXIT**.

To install batteries in the remote control, press up on the battery cover retainer clip and lift off the cover. Install the two AAA batteries with the correct polarity and then replace the cover.

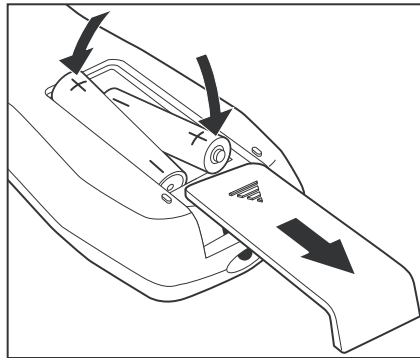

3.1 Remote Control

- Make sure that the battery polarities are correct when installing the batteries.
- Do not mix an old battery with a new one or different types of batteries.
- If you will not use the remote control for a long time, remove the batteries to avoid damage from battery leakage.
- Make sure that there is nothing obstructing the infrared beam between the remote control and the IR receiver on the projector.
- If the effective range of the remote control decreases, or it stops working, replace the batteries with new ones.
- The remote control may fail to operate if the infrared remote sensor is exposed to bright sunlight or fluorescent lighting.
- Ambient conditions may possibly impede the operation of the remote control. If this happens, point the remote control at the projector, and repeat the operation.

◀ *Notes on Batteries*

◀ *Notes on Remote Control Operation*

3.2 Quick Setup

Table 3-1 gives a quick overview of the Vision 120 installation process. The sections following this one provide detailed instructions.



Note

Installation should be performed by a qualified custom video installation specialist.

Table 3-1. Installation Overview

| Step | Procedure | For Details, Refer to page... |
|------|--|-------------------------------|
| 1 | Choose a location for the projector | 17 |
| 2 | If installing a Vision 120/CineWide or Vision 120/CineWide with AutoScope: Install fixed CineWide base plate or AutoScope lens motor | 24 |
| 3 | Mount the projector | 30 |
| 4 | Connect the VHD Controller to the projector | 31 |
| 5 | Connect signal sources to the VHD Controller | 32 |
| 6 | Connect external controller to RS-232 port (optional) | 37 |
| 7 | Connect 12-volt trigger outputs to AutoScope lens motor and/or other equipment (optional) | 38 |
| 8 | Connect projector, VHD Controller and lens motor (if present) to AC power and power up | 40 |
| 9 | For rear-screen and/or ceiling-mount installations, select the proper picture orientation | 40 |
| 10 | Primary lens adjustments: projected image size (zoom), position (shift) and focus | 19, 41 |
| 11 | Install CineWide anamorphic lens (optional) | 42 |
| 12 | CineWide lens adjustments: position, pitch (angle), geometry and focus | 44 |
| 13 | Projector calibration: adjust the following for each input ; save settings when finished: <ul style="list-style-type: none"> • Aspect ratio • Brightness • Contrast • Color level • Tint • Input position | 51 through 58 |

Proper installation of your projector will ensure the quality of your display. Whether you are installing a projector temporarily or permanently, you should take the following into account to ensure your projector performs optimally.

Choose the installation type that best suits your needs: front or rear screen, floor mount or inverted mount. Table 3-2 compares these various installation methods.

Table 3-2. Projector Installation Options

| Advantages | Considerations |
|--|--|
| Front Screen, Floor Mount Installation | |
| <ul style="list-style-type: none"> • Easy to set up • Can be moved or changed quickly • Easy to access | <ul style="list-style-type: none"> • Shares floor space with audience |
| Front Screen, Inverted Mount (ceiling) Installation | |
| <ul style="list-style-type: none"> • Does not take up audience space • Projector is unobtrusive • Projector cannot be accidentally moved | <ul style="list-style-type: none"> • Installation is more permanent • Projector access is more difficult |
| Rear Screen, Floor Mount Installation | |
| <ul style="list-style-type: none"> • Projector is completely hidden • Projector is easily accessed • Usually good ambient light rejection | <ul style="list-style-type: none"> • Requires separate room • Installation cost is usually higher |
| Rear Screen, Inverted Mount (ceiling) Installation | |
| <ul style="list-style-type: none"> • Projector is completely hidden • Usually good ambient light rejection | <ul style="list-style-type: none"> • Requires separate room • Installation cost is usually higher |
| Rear Screen, Floor Mount with Mirror | |
| <ul style="list-style-type: none"> • Projector is completely hidden • Usually good ambient light rejection • Requires less space behind screen than other rear screen installations | <ul style="list-style-type: none"> • Requires separate room • Installation cost is usually higher |

In general, minimize or eliminate light sources directed at the screen. Contrast ratio in your images will be noticeably reduced if light directly strikes the screen, such as when a shaft of light from a window or floodlight falls on the image. Images may then appear washed out and less vibrant.

3.3 Installation Considerations

◀ Installation Type

◀ Ambient Light

Throw Distance ➤ Throw distance is the distance measured from the front of the projector to the screen. This is an important calculation in any projector installation as it determines whether or not you have enough room to install your projector with a desired screen size and if your image will be the right size for your screen.

You can quickly estimate the throw distance by taking the width of the screen and multiplying it by the lens throw ratio; see Figure 3-1. The result of this calculation tells you roughly how far back the projector should be positioned from the screen in order to project a focused image large enough to fill the screen.

Estimating Throw Distance

Throw Distance (TD) = Screen Width (w) x Lens Throw Ratio

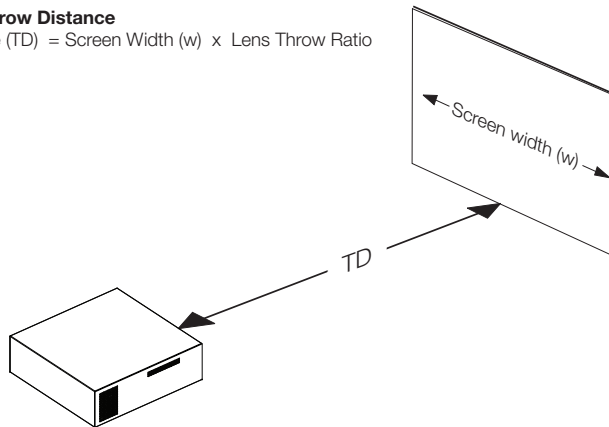

Figure 3-1. Estimating Throw Distance

Table 3-3 lists the available lens options for the Vision 120 and their associated throw ratios.

Table 3-3. Vision 120 Lens Options and Throw Ratios

| Lens Option (Note 2) | Throw Ratio with Primary Lens Only | Throw Range in inches, with 96x54-inch (1.78:1) Screen | | Throw Ratio with Primary Lens and Anamorphic Lens | Throw Range in inches, with 126.9x54-inch (2.35:1) Screen | |
|----------------------|------------------------------------|--|---------|---|---|---------|
| | | Minimum | Maximum | | Minimum | Maximum |
| A1 | 0.70 Fixed | 67.20 | | Not Applicable (Note 2) | | |
| A2 | 1.155 Fixed | 110.88 | | | | |
| B | 1.42 - 1.79 | 136.32 | 171.84 | | | |
| C | 1.86 - 2.51 | 178.56 | 240.96 | 1.42 - 1.88 | 180.20 | 238.57 |
| D | 2.67 - 4.19 | 256.32 | 402.24 | 2.03 - 3.13 | 257.61 | 397.20 |
| E | 4.32 - 6.98 | 414.72 | 670.08 | 3.15 - 5.48 | 399.74 | 695.41 |

Notes:

1. Throw distance does not affect image quality, provided these ranges are taken into account.
2. Only the C, D and E lenses can be used with the optional CineWide (secondary anamorphic) lens. Doing so affects the throw distances as shown here.

Proper placement of the projector relative to the screen will yield a rectangular, perfectly-centered image that completely fills the screen.

◀ **Vertical and Horizontal Position**

Ideally, the projector should be positioned perpendicular to the screen and in such a way that the lens center and screen center are aligned with each other, as shown in Figure 3-2.

Ceiling Installation

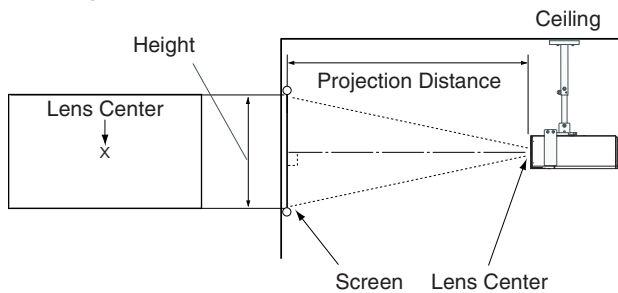

Floor Installation

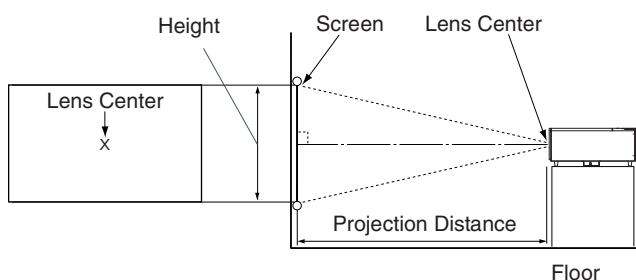
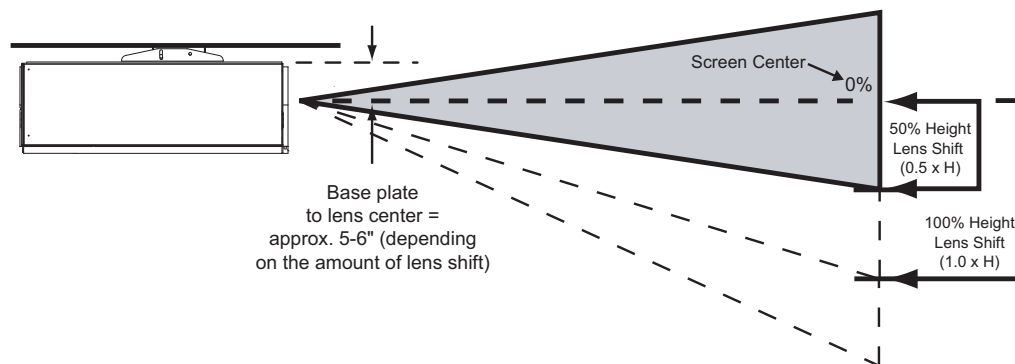

Figure 3-2. Projector Placement

If it is not possible to align the projector and screen as shown in Figure 3-2, you can use the lens shift controls to center the image on the screen. Lens shift is generally expressed as a percentage of the screen height or width, as shown in Figure 3-3 and Figure 3-4.

◀ **Vertical and Horizontal Lens Shift**



Note: This is a general example of lens shift. Lenses vary in their shift capabilities. **No particular lens or projector is used in this example.**

Figure 3-3. Vertical Lens Shift (EXAMPLE ONLY)

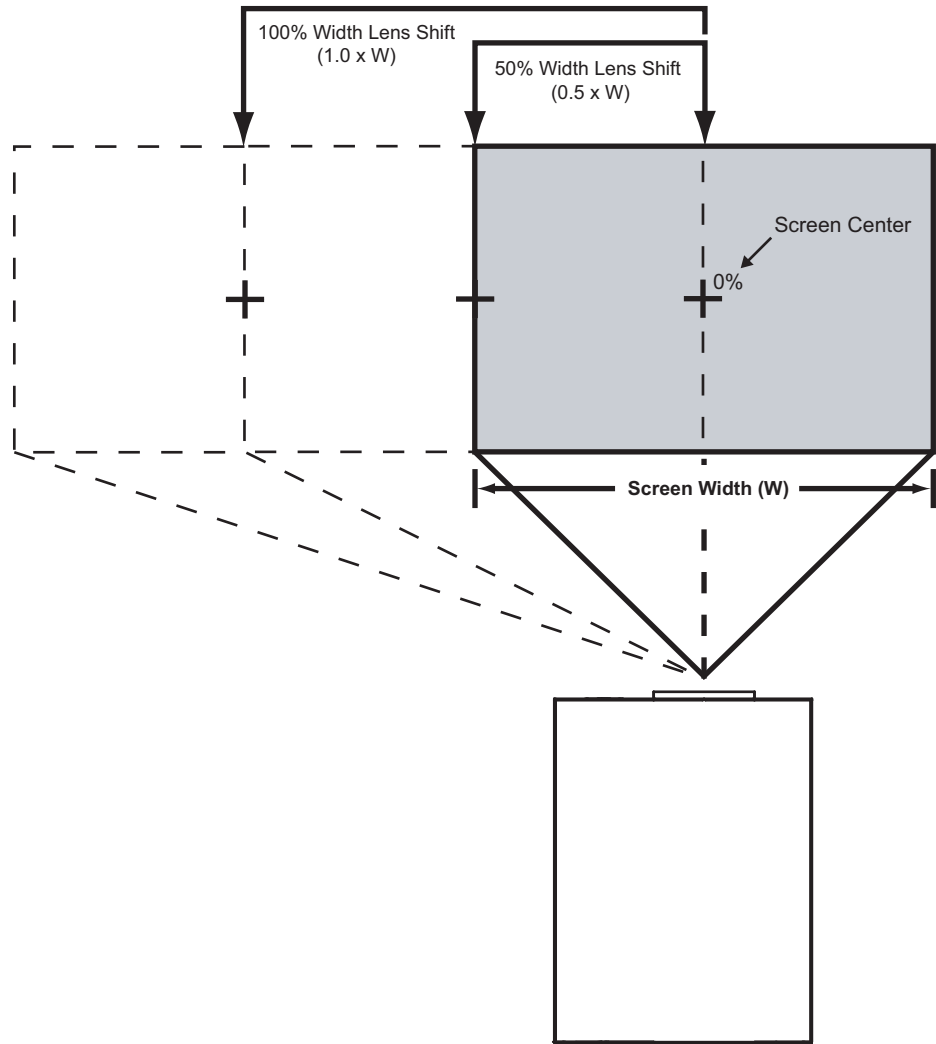

Note: This is a general example of lens shift. Lenses vary in their shift capabilities. **No particular lens or projector is used in this example.**

Figure 3-4. Horizontal Lens Shift (EXAMPLE ONLY)

Table 3-4 lists the lens shift limits for each available Vision 120 lens, as percentages and absolute measurements with a 100 x 56 inch (1.78:1) screen.

Table 3-4. Vision 120 Vertical and Horizontal Lens Shift Limits

| | | Lens Option | | | | | |
|--|-------|-------------|-------|-------|-------|-------|-------|
| | | A1 | A2 | B | C | D | E |
| Lens Shift Limits, as Percentages of Screen Height or Width (Notes 1 and 2) | | | | | | | |
| Vertical (Note 2) | Up | 10% | 31% | 30% | 32% | 28% | 30% |
| | Down | 10% | 71% | 61% | 62% | 65% | 63% |
| Horizontal (Note 2) | Left | 5% | 17% | 12% | | | |
| | Right | 5% | 17% | 12% | | | |
| Lens Shift Limits in Inches, with a 100-by-56 inch (1.78:1) Screen | | | | | | | |
| Vertical | Up | 5.60 | 17.36 | 16.80 | 17.92 | 15.68 | 16.80 |
| | Down | 5.60 | 39.76 | 34.16 | 34.72 | 36.40 | 35.28 |
| Horizontal | Left | 5.00 | 17.00 | 12.00 | | | |
| | Right | 5.00 | 17.00 | 12.00 | | | |
| <p>Notes:</p> <ol style="list-style-type: none"> 1. With no vertical or horizontal lens shift, the lens center and screen center are aligned with each other. 2. Vertical shift limits are percentages of the screen height. Horizontal shift limits are percentages of the screen width. 3. Vertical lens shift figures apply to ceiling mount configurations. For floor installations (where the projector is upright), reverse the up/down vertical offset percentages. | | | | | | | |

In rear screen applications where space behind the projector is limited, a mirror may be used to fold the optical path, as shown in Figure 3-5. The position of the projector and mirror must be accurately set. If you are considering this type of installation, contact your dealer for assistance.

◀ **Folded Optics**

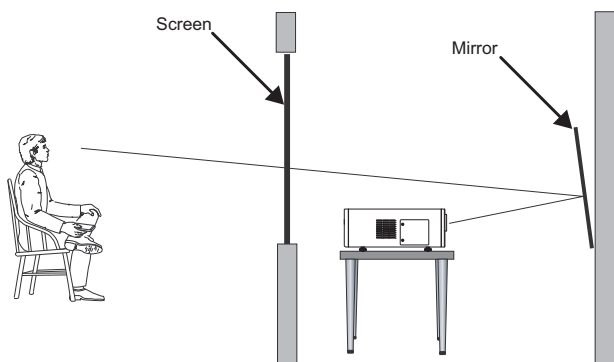

Figure 3-5. Folded Optics

Other Considerations ➤

Other considerations and tips that can help improve your installation:

- Keep the ambient temperature constant and below 35°C (95°F). Keep the projector away from heating and/or air conditioning vents. Changes in temperature may cause drifts in the projector circuitry, which may affect performance.
- Keep the projector away from devices that radiate electromagnetic energy such as motors and transformers. Common sources of these include slide projectors, speakers, power amplifiers and elevators.

3.4 Installing the Primary Projection Lens

The projection lens is shipped separately from the projector. To install it, proceed as follows:

1. Using a 2.5-mm hex wrench, loosen the two hex screws holding the Projector Front Jewelry in place.



2. Remove the jewelry.



3. Remove the Lens Cavity Front Cover.

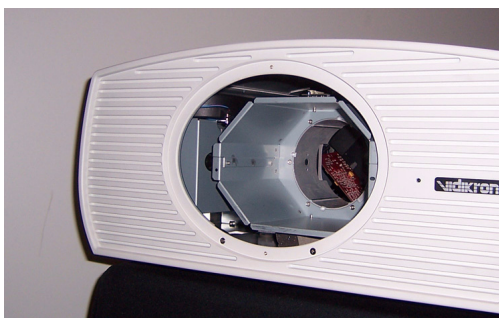

4. Remove the Rear Lens Cap.



5. Hold the lens assembly with the motor facing the right side of the Lens Cavity. **Carefully** insert the back of the lens assembly into the hole in the lens flange.

Gently push the lens assembly in until it is seated flush against the flange and the motor connectors have seated.



Caution

Make sure to route the wire harness in its original position and away from the moving lens stages and Motor Assembly, to prevent unexpected disconnection or lens damage.

6. Lock the lens in place by turning the Lens Locking Nut (to the left of the lens) 180 degrees counter-clockwise. (Use a 6.0mm hex wrench.)

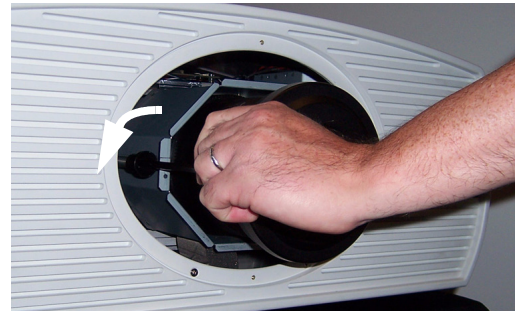

7. Remove the Front Lens Cap.



8. Replace the Lens Cavity Front Cover.



9. Re-install the Projector Front Jewelry. Tighten the hex screws at the top and bottom of the jewelry to secure it.



3.5 Installing the Optional CineWide Lens Mount

If you are installing a standard (non-CineWide) Vision 120, skip this step and proceed with **Mounting the Vision 120** (page 30).

If you are installing a Vision 120/CineWide, proceed with **Installing the Fixed CineWide Base Plate (Vision 120/CineWide)** (page 29).

If you are installing a Vision 120/CineWide with AutoScope, proceed as follows to install the AutoScope lens motor.

**Note**

1. Do not install the CineWide lens yet, only the fixed CineWide base plate or AutoScope lens motor. You will install the CineWide lens after you install the projector and adjust the primary lens.
2. Some components shipped with your projector may differ slightly from what is shown in these instructions.

Figure 3-6 shows the Vision 120/CineWide with AutoScope motor assembly.

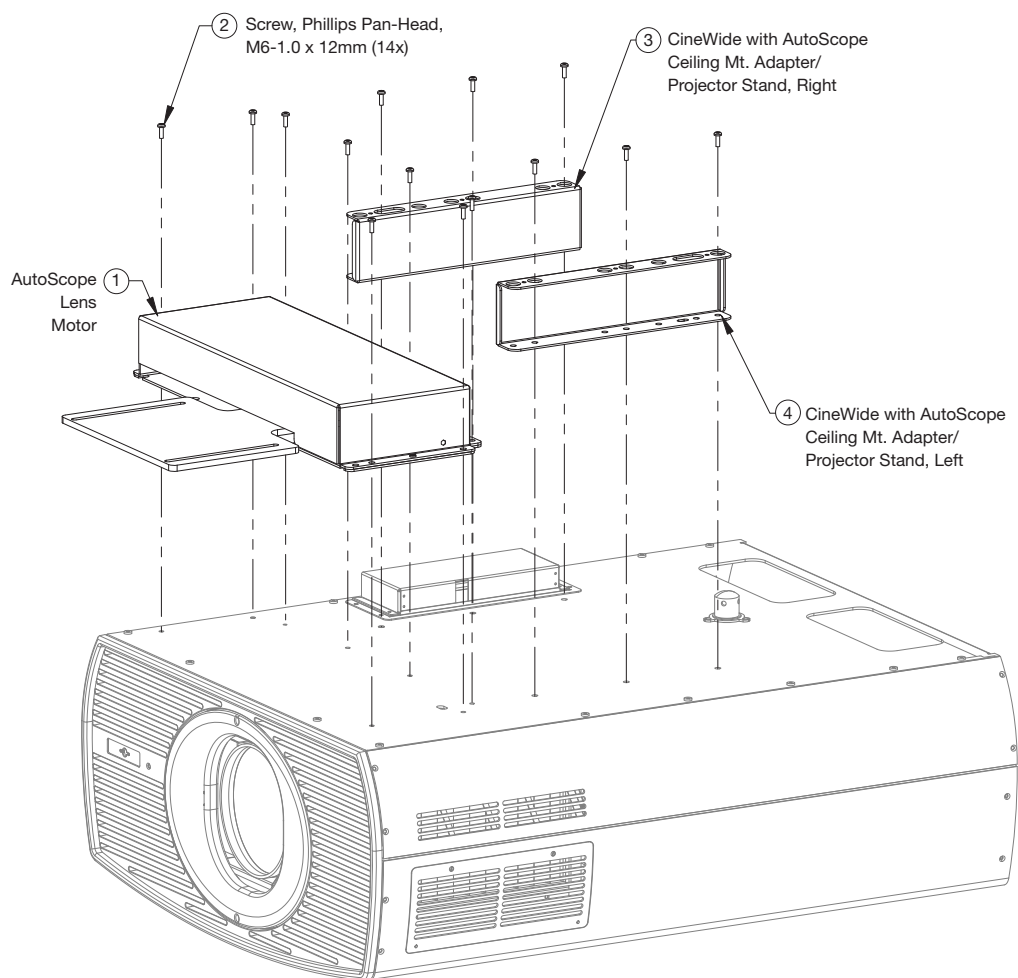

◀ **Installing the AutoScope Lens Motor (Vision 120/CineWide with AutoScope)**

Figure 3-6. Vision 120/CineWide with AutoScope Motor Assembly - Exploded View

Remove Projector Front Feet: Place the projector upside down on a blanket or other soft surface. Loosen and remove the two front feet on the projector.

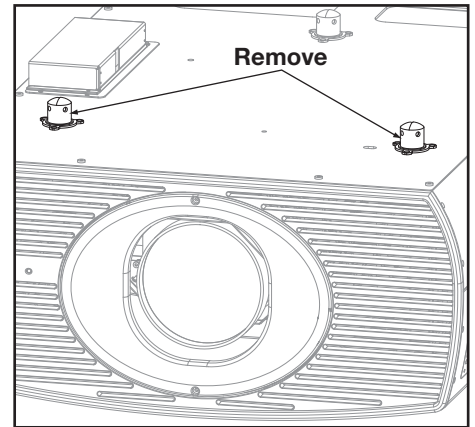

Install Ceiling Mount Adapters/Projector Stands: For ceiling installations, the adapters bring the attachment points for the projector mounting rails (included with the projector ceiling mount kit) from the bottom of the projector up and around the AutoScope lens motor housing. For floor installations (where the projector is upright), the adapters allow the projector to lie flat on the mounting surface.

Using six (6) each of the supplied, M6 x 12mm Pan-Head Phillips screws (item #2), attach the AutoScope Ceiling Mount Adapters/Projector Stands (items #3 and #4) to the projector as shown in Figure 3-7.

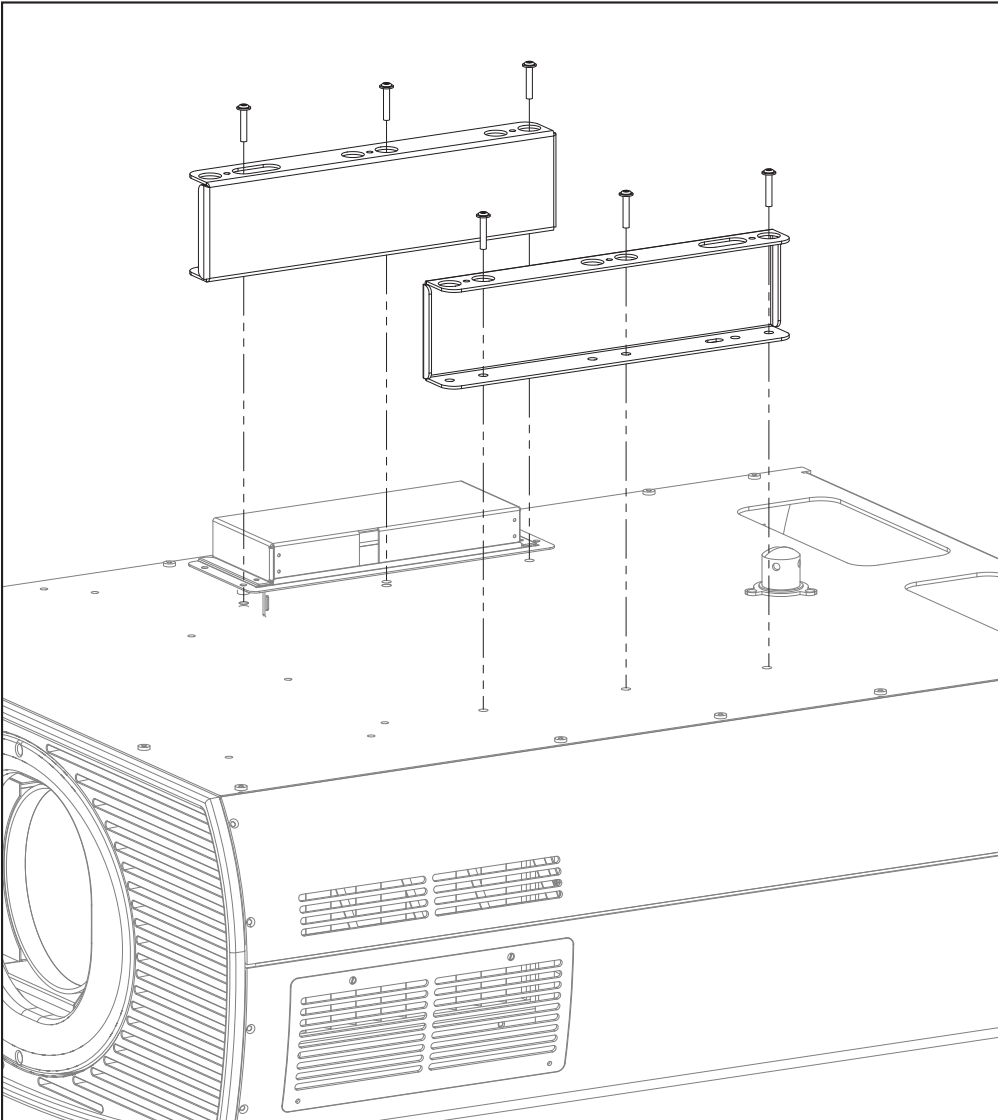

Figure 3-7. Vision 120 with Ceiling Mount Adapters/Projector Stands



Caution

DO NOT OVER-TIGHTEN THE SCREWS.

Install Lens Motor: Position the AutoScope Lens Motor (item #1) as shown in Figure 3-8. Line up the mounting holes on the lens motor housing with those on the underside of the projector. Secure the motor to the projector with the eight (8) remaining M6 x 12mm Pan-Head Phillips screws (item #2).

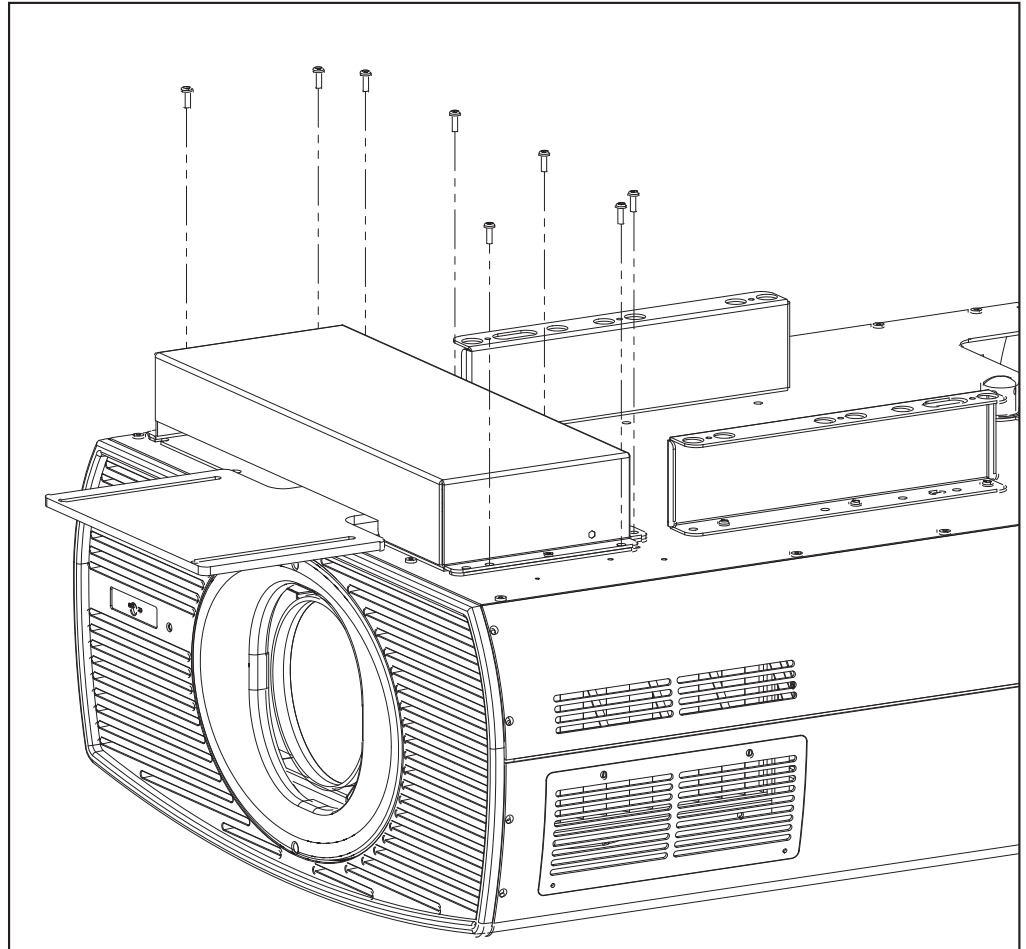

Figure 3-8. AutoScope Lens Motor Installation

After you have installed the AutoScope lens motor, proceed with **Mounting the Vision 120** (page 30).

To install the fixed CineWide base plate on a Vision 120/CineWide:

1. Place the projector upside down on a blanket or other soft surface.
2. Line up the mounting holes on the lens mount base plate with those on the bottom of the projector, directly below the primary lens (see Figure 3-9).
3. Secure the base plate to the projector with the screws provided for this purpose.

◀ **Installing the Fixed CineWide
Base Plate (Vision
120/CineWide)**

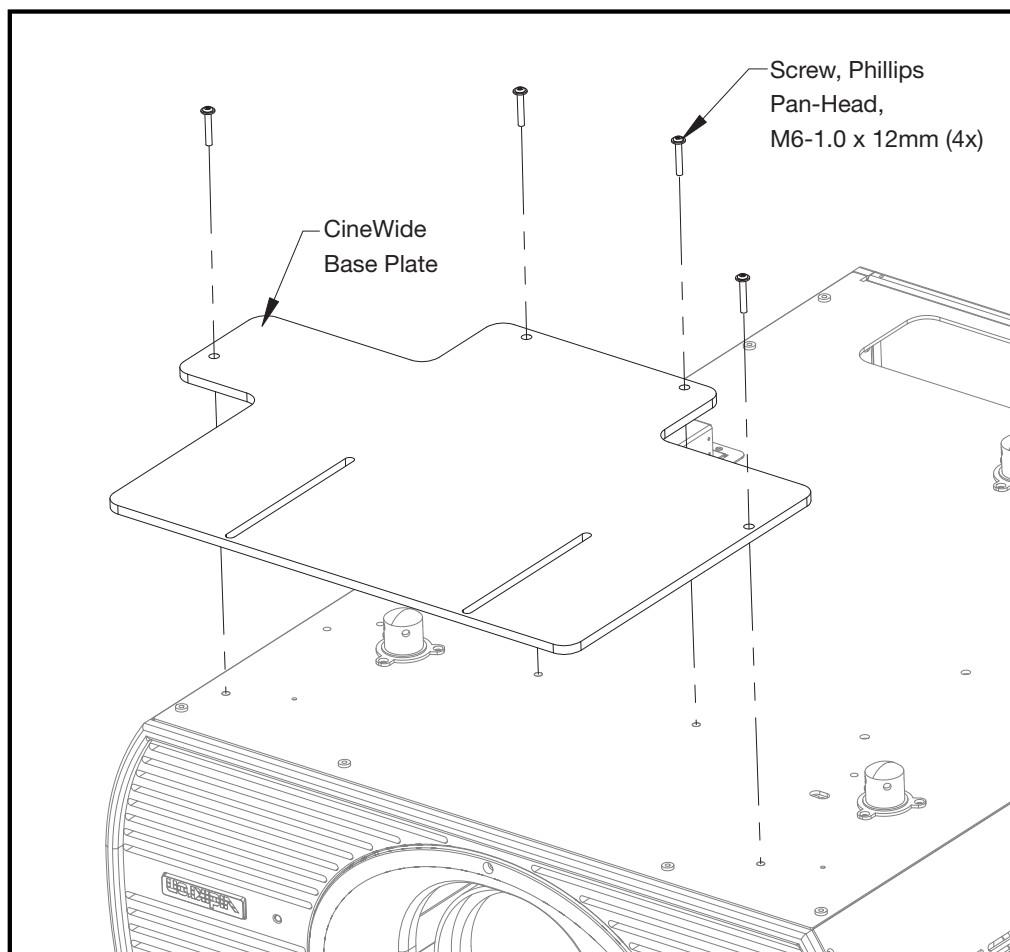

Figure 3-9. Installing the Fixed CineWide Base Plate

3.6 Mounting the Vision 120

There are several methods for mounting the projector. Depending on your chosen installation, one method may be more suitable than another.

Floor Mounting (Upright) ➤ In typical front and rear screen installations, the projector can be mounted to a secure and level surface such as a table or cart. Carts are useful when moving a projector during a presentation or from site to site. If possible, lock the wheels when it's in position to prevent it from being moved during a presentation.

Ceiling Mounting (Inverted) ➤ For fixed installations, and for those that want the projector out of sight or have a limited space for projector and audience, you can invert the Vision 120 and suspend it from the ceiling using a specially-designed ceiling mount fixture.



Note

Use only the Vidikron-approved ceiling mount kit designed for your projector (part number 956-0247-00). Install the mount kit according to the instructions provided with it.

The projector can also be inverted and placed in an enclosure above and behind the viewing area. Install four feet on the inside bottom surface of the enclosure on which the projector can rest. A variety of materials can be used for this purpose (for example, rubber crutch tips or turntable feet).

Adjusting the Projection Angle ➤ If the Vision 120 is ceiling-mounted and the screen is significantly lower than the projector, you can tilt the projector at a slight angle by adjusting the ceiling mount.

If you do this, you may need to shift the image using the on-screen display (OSD) controls, to compensate. For detailed instructions, refer to **Using the On-Screen Menus** on page 49.

Proceed as follows to connect the VHD Controller to the Vision 120, your video sources, external controller(s) – if present – and AC power.

When connecting your equipment:

- Turn off all equipment before making any connections.
- Use the correct signal cables for each source.
- Ensure that the cables are securely connected. Tighten the thumbscrews on connectors that have them.

To access the connector panel, press the door release button so it pops out. Turn the knob clockwise or counter-clockwise and pull gently on it to open the door.

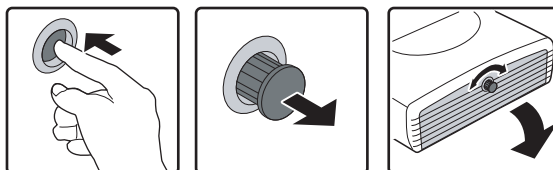

3.7 Connections to the Vision 120 and VHD Controller

◀ Connector Panel Access

The Vision 120 is designed to receive only digital input signals directly from the companion VHD Controller/Processor. All signal sources should be connected to the appropriate inputs on the rear panel of the controller. The signal from the controller is then output to the Vision 120 projector through a DVI-DL (dual-link) cable.

◀ Connecting the VHD Controller to the Vision 120



Note

You CANNOT connect a signal source with DVI output directly to the Vision 120. It MUST be routed through the VHD Controller for proper operation.

Use a Vidikron DVI Dual-Link (DVI-DL) cable to connect the output of the VHD Controller to the input of the Vision 120; see Figure 3-7.

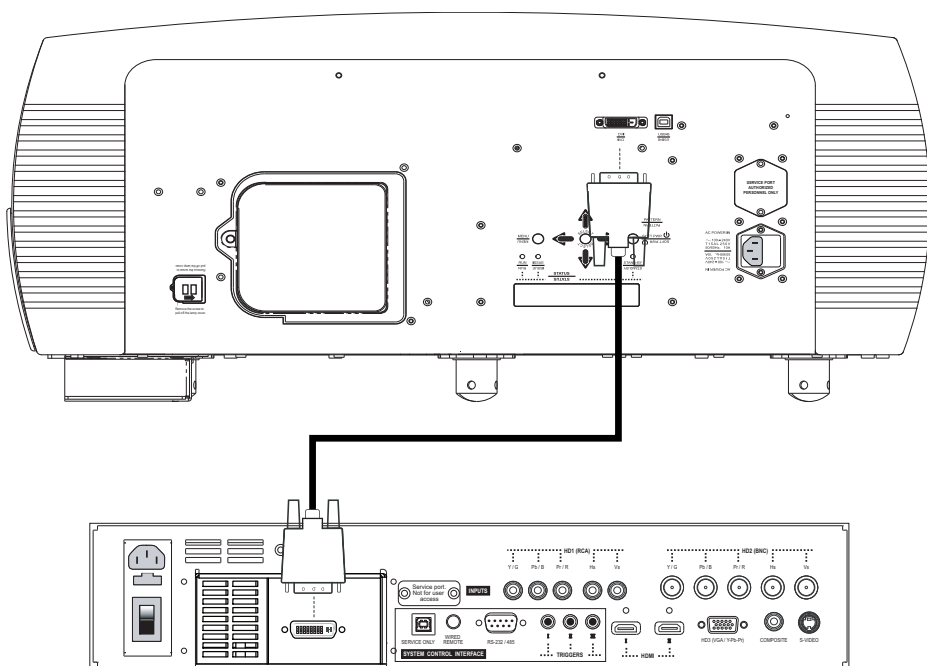

Figure 3-10. Connecting the Vision 120 to the VHD Controller

Connecting Source Components to the VHD Controller

Connect your video sources to the VHD Controller as shown and described in the sections that follow.

HDMI Connections: See Figure 3-11.



Tip

Use the HDMI inputs whenever possible. This ensures the highest video quality because the signal is carried in the digital domain throughout the entire signal path, from source component output into the projector.

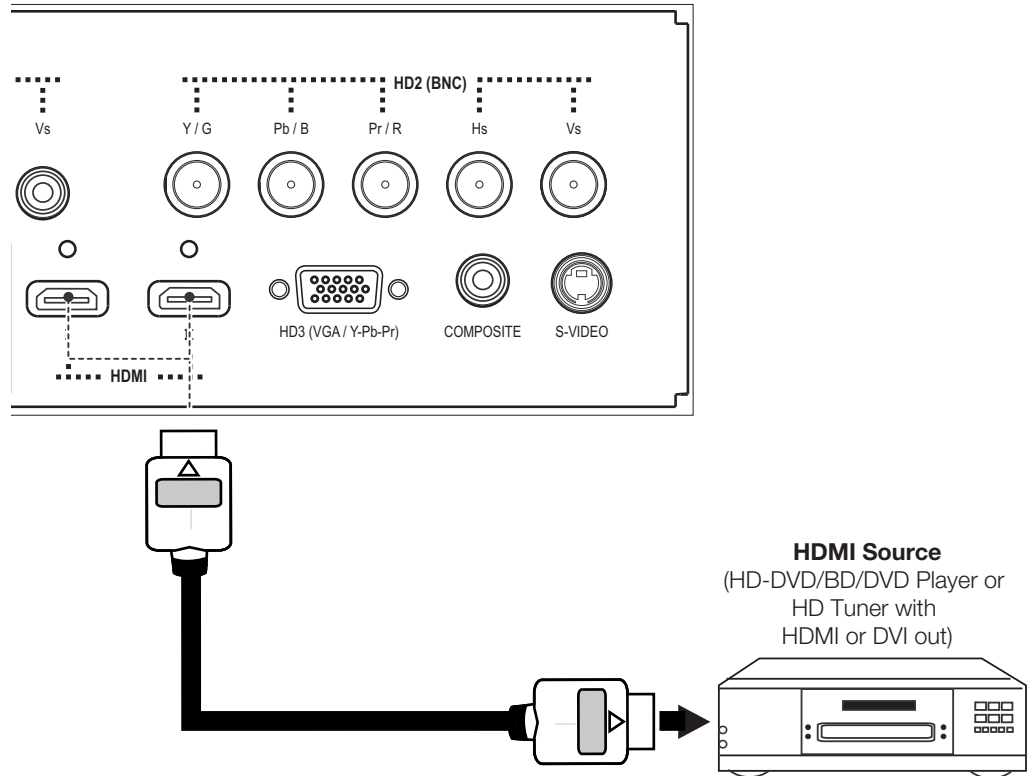

Figure 3-11. HDMI Source Connections

Digital (DTV) RGB or Component Video Connections: See Figure 3-12 and Figure 3-13.

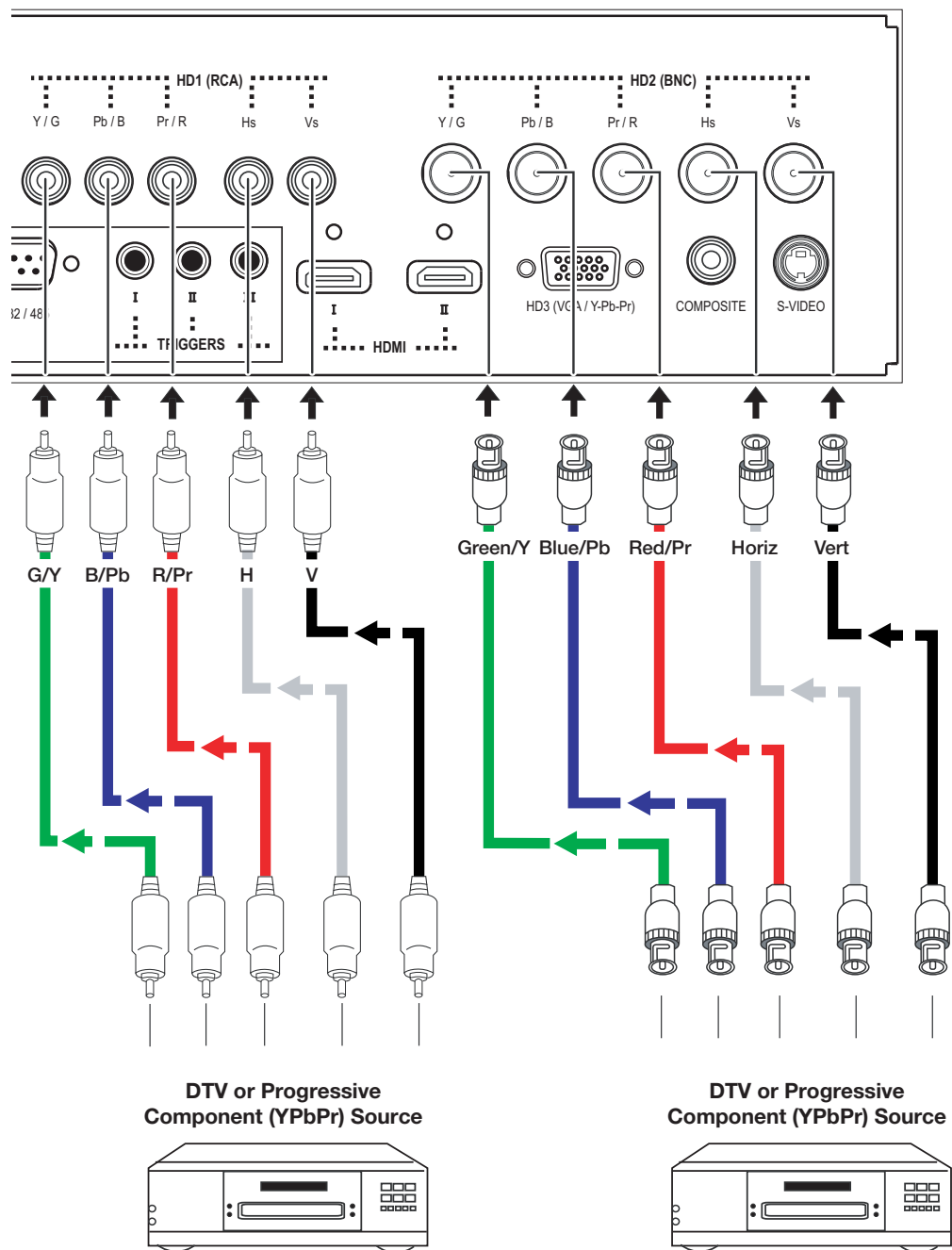

Figure 3-12. Digital (DTV) RGB or Component Video Connections (HD1, HD2)

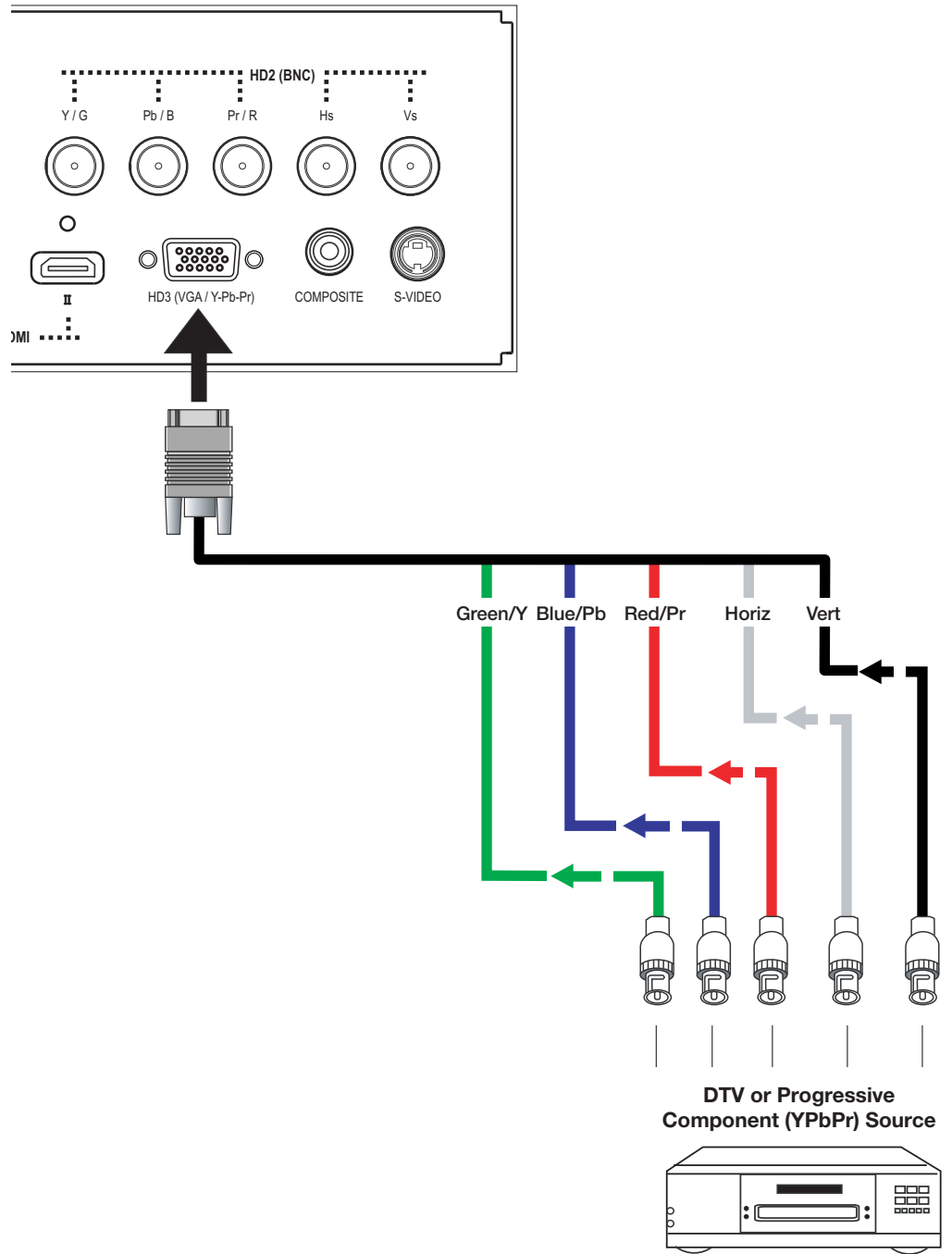

Figure 3-13. Digital (DTV) RGB or Component Video Connections (HD3)

Analog (Computer) RGB Connections: See Figure 3-14.

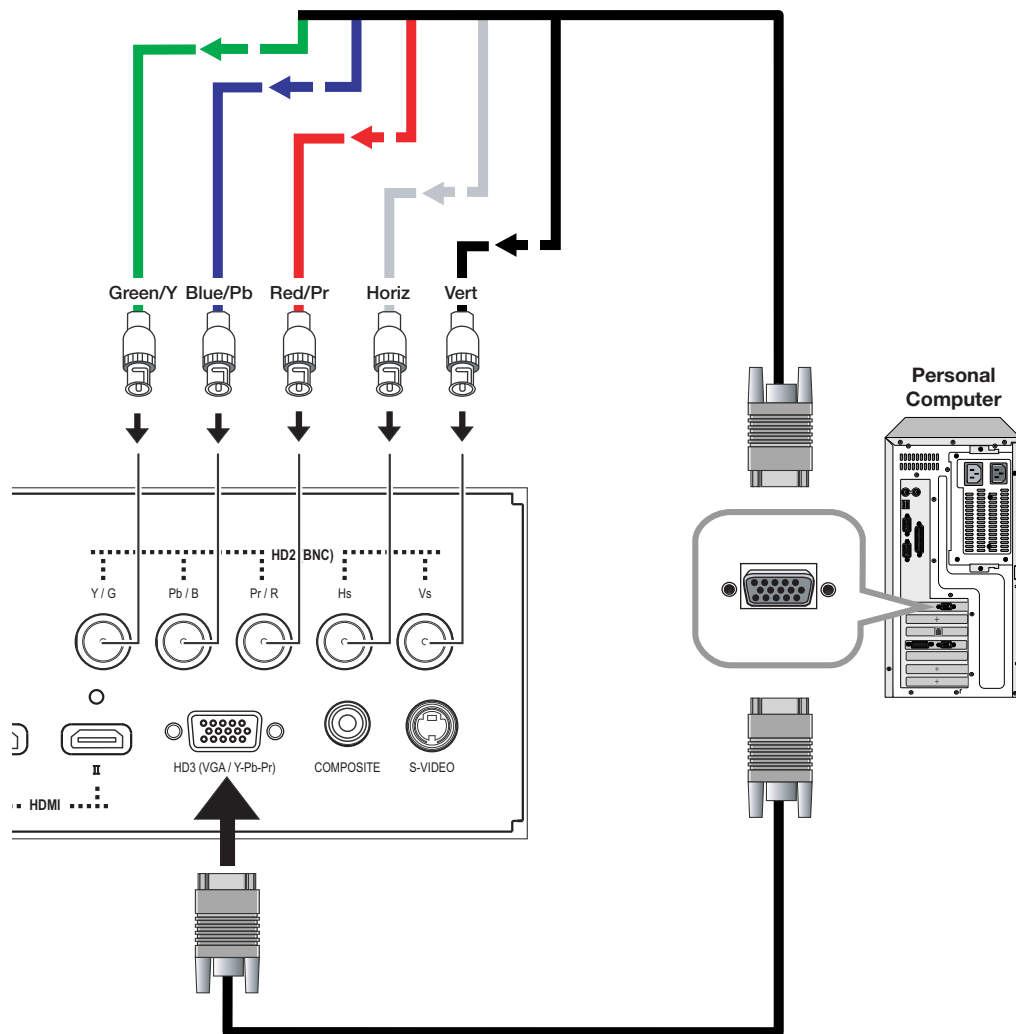

Figure 3-14. Analog RGB Connections

S-Video/Composite Video Connections: See Figure 3-15.

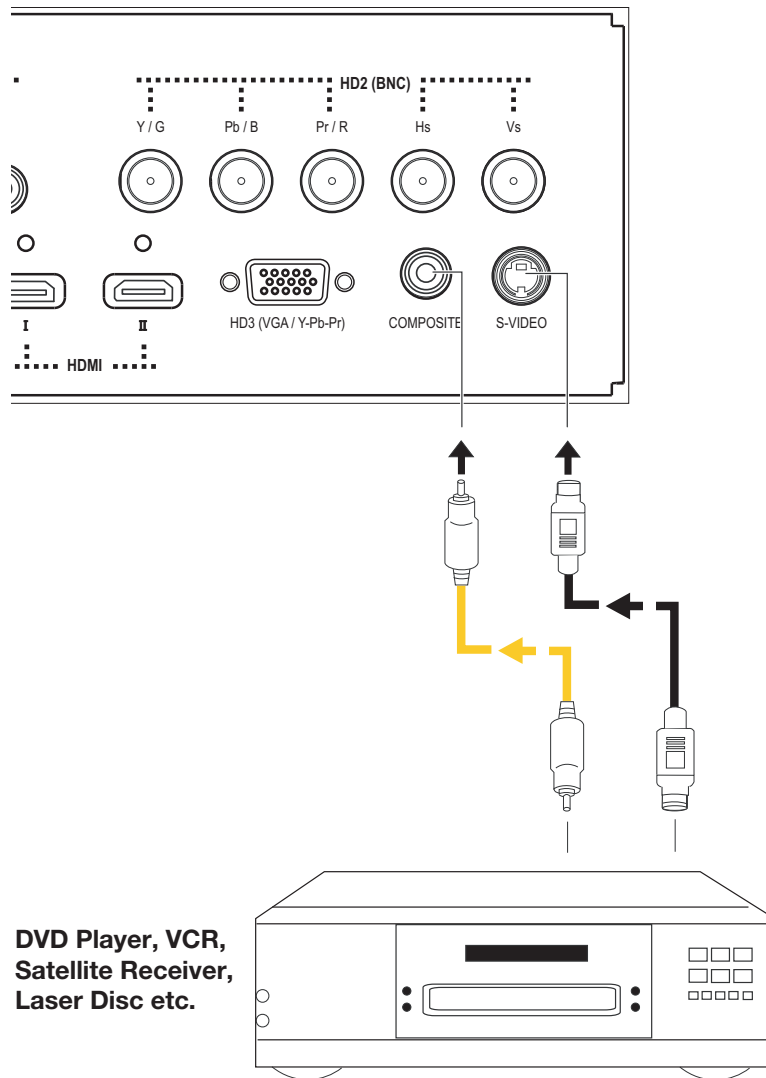

Figure 3-15. S-Video and Composite Video Connections

Use a “null-modem” 9-pin RS-232 cable to connect a PC or home theater control/automation system (if present) to the RS-232/485 port on the VHD Controller; see Figure 3-16.

◀ **RS-232 Controller Connection**

For more information about using this connection, refer to **Serial Communications** on page 67.

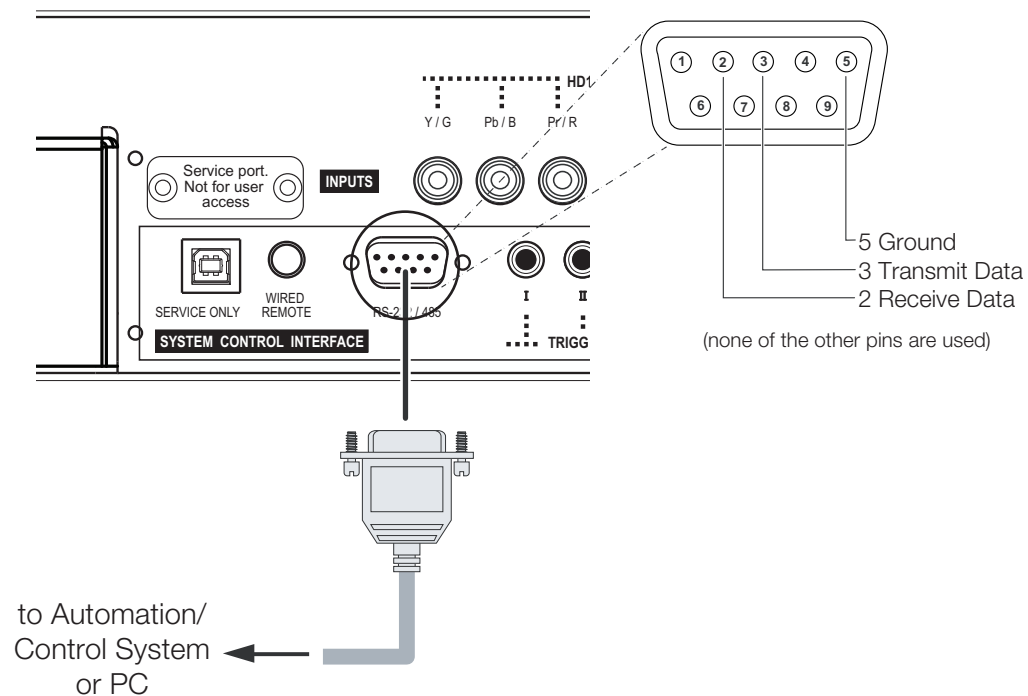

Figure 3-16. RS-232 Control System Connection

Connecting 12-Volt Trigger Outputs to External Theater Equipment

If your Vision 120 is equipped with a CineWide with AutoScope system, connect the AutoScope lens motor to a 12-volt trigger output on the VHD Controller; see Figure 3-17. Similarly connect other 12-volt trigger-activated equipment (such as retractable screens or screen masks) to the other trigger outputs. For more information on using the VHD Controller triggers, refer to **Triggers** on page 62.

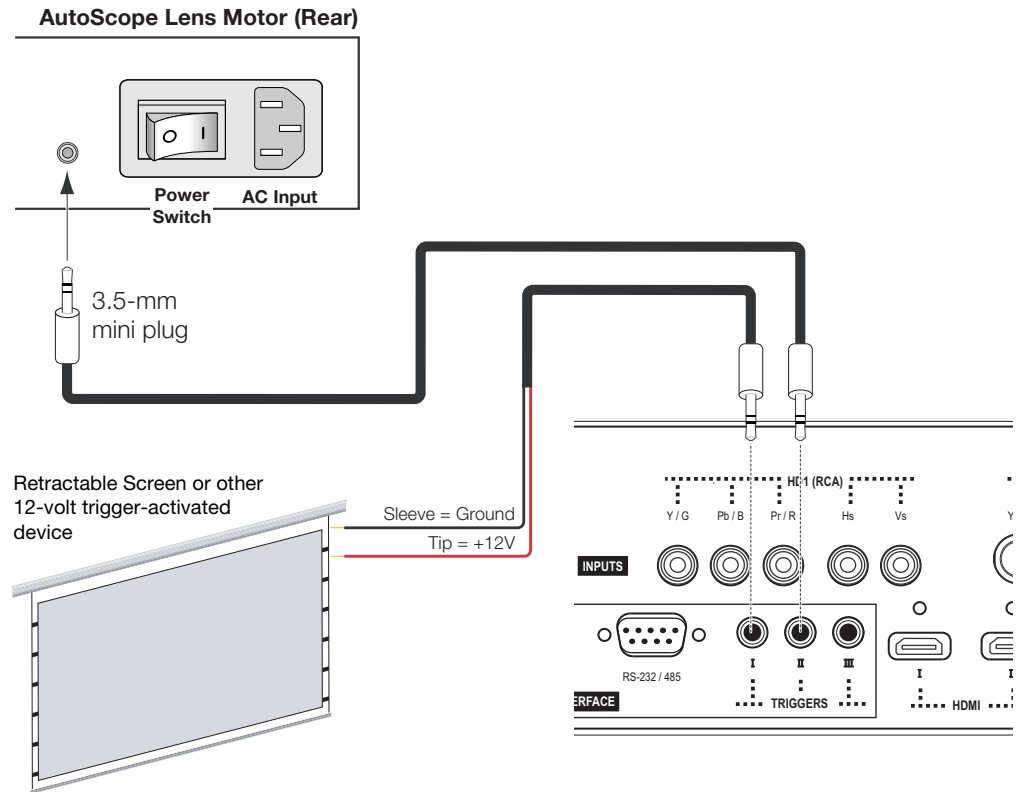

Figure 3-17. 12-volt Trigger Output Connections

If infrared signals from the remote control cannot reach the VHD Controller due to excessive distance or obstructions such as walls or cabinet doors, you can connect an external IR receiver to the WIRED REMOTE input on the VHD Controller to extend the range of the remote control. See Figure 3-18.

◀ **Connecting an External IR Receiver to the VHD Controller**

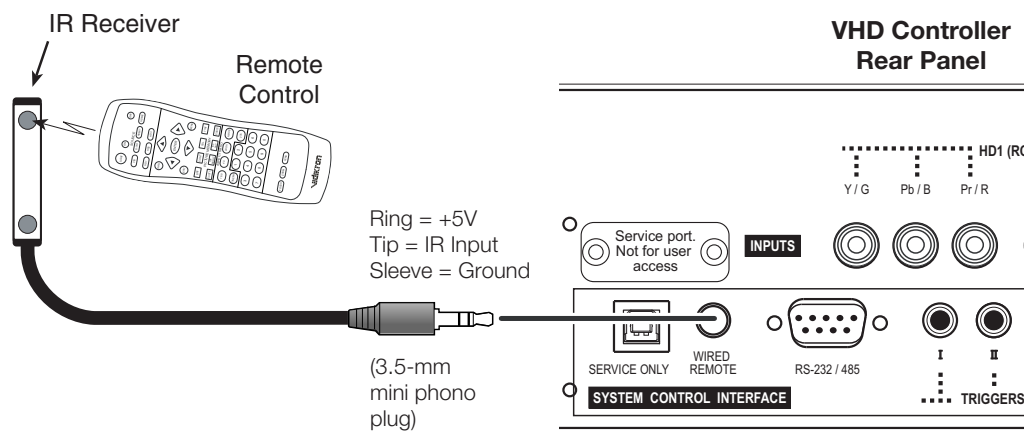

Figure 3-18. External IR Receiver Connection



Note

When an external IR receiver is connected to the wired IR input, the built-in IR sensor on the VHD Controller is disabled.

Connecting to AC Power ➤ **Projector/VHD Controller:** Plug the female end of one power cord into the AC receptacle on the rear of the Vision 120 (AC 100V ~ 240V). Then, connect the other end to your AC power source.

Similarly connect the VHD Controller to a nearby AC outlet.

AutoScope Lens Motor: With AutoScope-equipped projectors, an additional power cord is provided for the lens motor. Plug the female end of the AC power cord into the AC input on the rear of the lens motor assembly. Connect the other end to a 110 VAC power source.



Caution

*The input voltage to the AutoScope lens motor must be between 100 and 120 VAC. **Do not connect the AutoScope lens motor to a 200-240 VAC power source!***

3.8 Turning on the Power

1. Turn on your source components.
2. Turn on the main power switch at the rear of the VHD Controller.
3. If this is an AutoScope-equipped projector, turn on the main power switch at the rear of the AutoScope lens motor. The lens motor power switch is located next to the AC input (see Figure 3-17).
4. Press the **ON** button on the remote control – or the **SOFT PWR** button on the VHD Controller front panel – to turn on the system. The vacuum fluorescent display on the VHD Controller front panel briefly displays “Starting Display.”
5. When the projector is ready for use (after about 20 seconds), the **RUN** LED on the VHD Controller front panel lights solid blue. The fluorescent display indicates the current input source, aspect ratio and input resolution; for example:

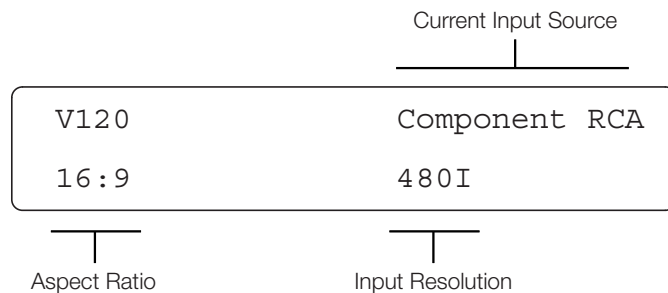

3.9 Adjusting the Picture Orientation

By default, the Vision 120 is configured for a “floor/front” installation, in which the projector is installed upright and in front of the screen. If it is installed behind the screen and/or inverted, you must change the picture orientation. To do this:

1. Press **MENU**.
2. Select Service from the Main Menu and enter the Service Menu passcode.
3. Select Display Device from the Service Menu.
4. Select Installation from the Display Device menu.
5. Choose Floor Rear, Ceiling Front or Ceiling Rear, to match the installation method.

**Note**

You must enter a passcode to access the Service menu.

To access the motorized lens controls, use the FOCUS, ZOOM and LENS buttons on the Vision 120 remote control unit (described on page 14).

Alternatively, select Display Device from the Service Menu. Select Configure, then Lens from the Display Device menu. The Lens menu gives you a great deal of control over the picture size, position and focus:

To focus the projected image, use the cursor buttons to highlight "In" or "Out." Then, press and hold the **ENTER** button on the remote control.

To make the picture smaller (zoom out), use the cursor buttons to highlight the minus sign (-). Then, press and hold the **ENTER** button on the remote control.

To enlarge the picture (zoom in), use the cursor buttons to highlight the plus sign (+). Then, press and hold the **ENTER** button on the remote control.

To change the projected image position, use the cursor buttons to highlight "Left," "Right," "Up" or "Down" in the Lens menu. Then, press and hold the **ENTER** button to shift the image in that direction.

3.10 Primary Lens Adjustments

◀ **Focus**

◀ **Zoom**

◀ **Vertical and Horizontal Lens Shift**

3.11 Installing and Adjusting the CineWide Anamorphic Lens

If you are installing a CineWide-equipped projector, proceed as follows to install and adjust the anamorphic lens.



Note

It is extremely important that the primary lens is properly adjusted before you install the anamorphic lens. Ensure that the image from the primary lens is perfectly centered on the screen.

Attach Lens Mounting Assembly to Lens Motor Carriage Plate (CineWide with AutoScope) or Base Plate (fixed CineWide)

The Vision 120 Anamorphic lens mount kit consists of everything shown in Figure 3-19. Some components shipped with your projector may differ slightly from what is shown in these instructions. If any items are missing or damaged, please contact your Vidikron dealer or Vidikron Customer Service at (888) 4VIDIKRON.

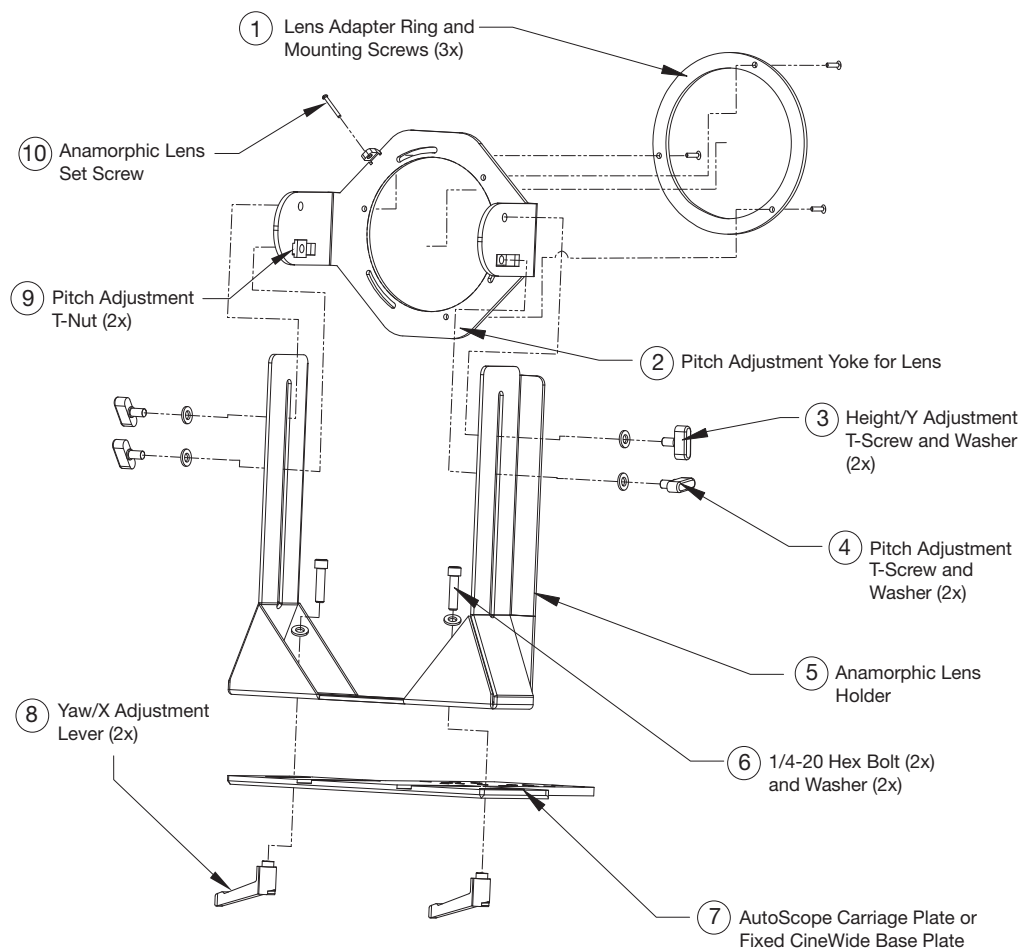

Figure 3-19. Vision 120 Anamorphic Lens Mounting Assembly - Exploded View

1. Remove the two Yaw/X Adjustment Levers (item #8) from the bottom of the Anamorphic Lens Holder (item #5).
2. Place the Anamorphic Lens Holder on top of the AutoScope Carriage Plate or fixed CineWide Base Plate (item #7). Position the bracket so that the long slot at the bottom of the lens holder is perpendicular to the corresponding slots on the plate.

3. Secure the Anamorphic Lens Holder to the plate using the Hex Bolts/Washers (item #6) and Yaw/X Adjustment Levers that you removed in Step 1.
4. Use the Lens Mounting Screws to attach the Lens Adapter Ring (item #1) to the Pitch Adjustment Yoke (item #2); see Figure 3-20. (Use the round, threaded holes on the yoke.)
5. Use the Height/Y Adjustment T-Screws (item #3), Pitch Adjustment T-Screws (item #4) and T-Nuts (item #9) to attach the Pitch Adjustment Yoke and Lens Adapter Ring to the Anamorphic Lens Holder. **The Yoke should be as close to the primary lens as possible.**
6. Attach the lens to the Lens Adapter Ring by threading it clockwise.

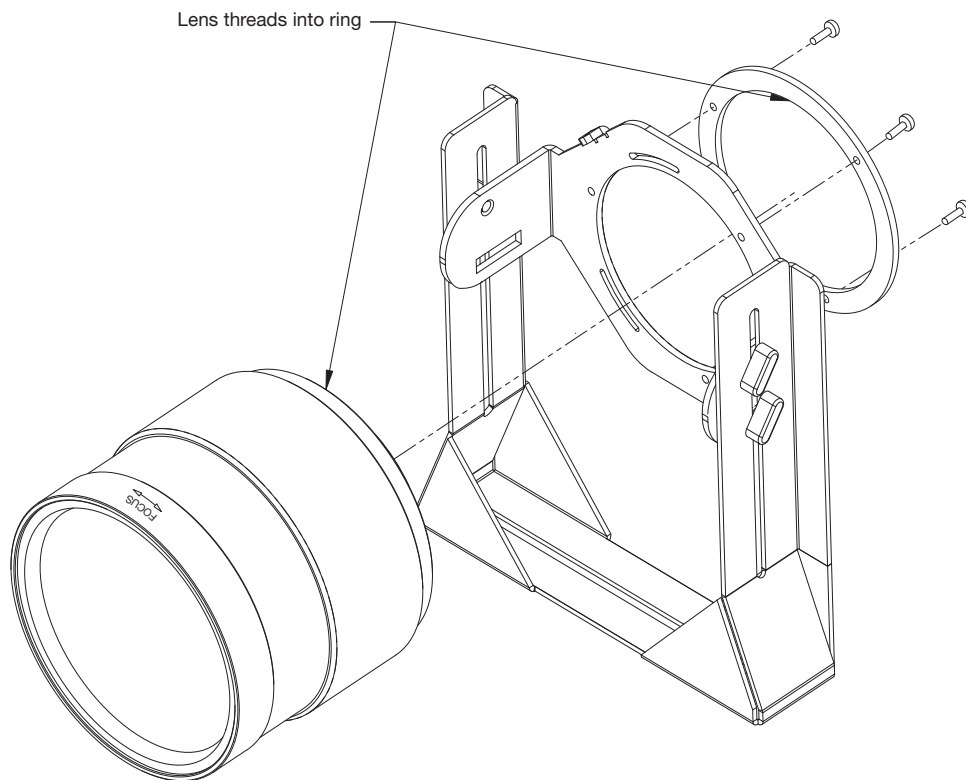
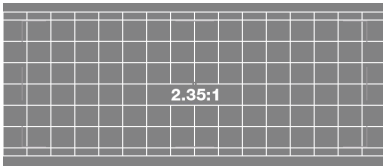

Figure 3-20. Attaching the Anamorphic Lens to the Lens Adapter Ring

Configure Lens Motor Trigger ➤

CineWide with AutoScope maintains constant image height independent of the aspect ratio, while using the full display resolution of the projector. It accomplishes this by moving the anamorphic lens in front of the primary lens when widescreen material is being viewed. When the viewer transitions back to 16:9 or 4:3 source material, the anamorphic lens moves out of the light path.

To configure the lens motor trigger on the VHD Controller for proper AutoScope operation:



1. Project a 2.35:1 aspect ratio test pattern or other image on the screen.
2. Press **MENU** on the remote control and enter the Service menu passcode.
3. Select **Service** from the Main menu.
4. Select **Triggers** from the Service menu.
5. Assign the trigger output to which the lens motor is connected to the Cinema and IntelliWide 2.35 aspect ratios. This enables the lens motor to move the anamorphic lens into position (in front of the primary lens) when either aspect ratio is selected.
6. To save the trigger settings, press ▼ repeatedly to highlight "Save." Then, press **ENTER**.
7. Select the Cinema aspect ratio to move the anamorphic lens into position, if it isn't already. To do this, press **CINEMA** on the VHD Controller remote control (Figure 2-5), or press ▲ or ▼ repeatedly with no menus visible on-screen.

Adjust the Anamorphic Lens ➤

Adjusting the Horizontal (X) Lens Position:

1. Project a white field on the screen.
2. Loosen the Yaw/X-Adjustment Levers underneath the lens.
3. Slowly move the anamorphic lens into place so that there are no shadows on either side of the screen:

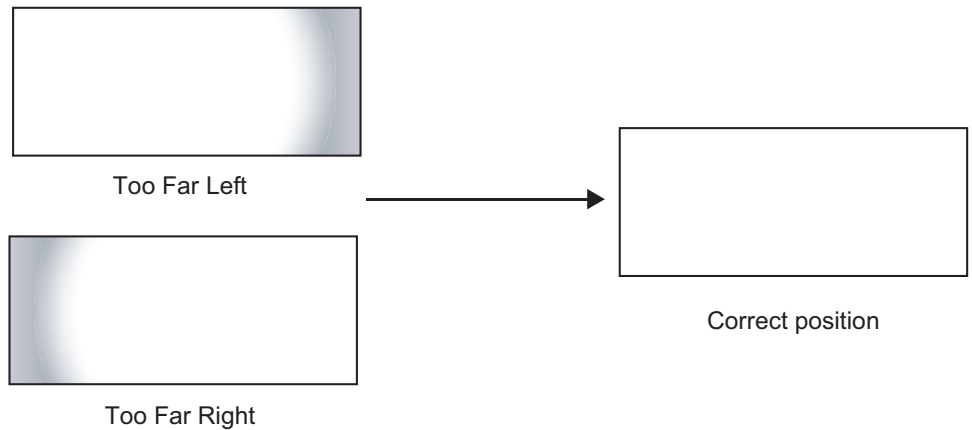

4. When the horizontal position is properly set, tighten the Yaw/X-Adjustment Levers to secure the lens in place.

Adjusting the Height (Y): With the white field still on-screen, loosen the Height/Y Adjustment T-Screws on either side of the lens. Then, slowly move the anamorphic lens into place so that there are no shadows on the top or bottom of the screen:

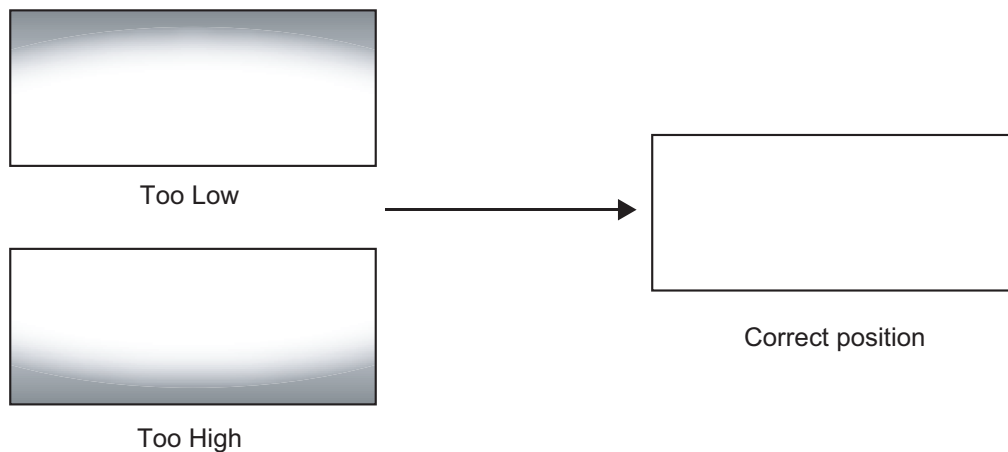

When the height is properly set, tighten the Height Adjustment T-Screws to secure the lens in place.

Pitch (Angle): Next, angle the lens to even out any top-to-bottom pincushion distortion. To do this, loosen the Pitch Adjustment T-Screws (directly below the Height/Y Adjustment T-Screws) on either side of the lens to allow it to pivot freely. Then, adjust the anamorphic lens angle so that the projected image is rectangular:

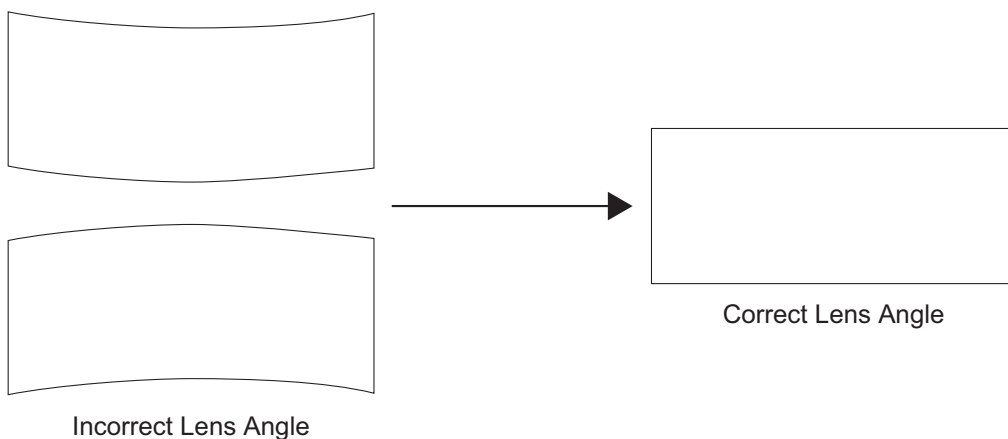

The anamorphic lens will almost always be angled with respect to the projector; this is normal.

Once the proper lens angle has been set, firmly tighten the Pitch Adjustment T-Screws to secure the lens in place.



Note

There may be some pincushion distortion even after the lens is properly adjusted, especially at shorter throw distances. If this is the case, Vidikron recommends that you slightly over-scan the image into the screen frame area to mask the distortion.

Adjusting the Yaw: Loosen the Yaw/X-Adjustment Levers to allow the lens to pivot freely from side to side. Then, angle the lens to even out any left-right pincushion distortion:

Anamorphic Lens (Top View)

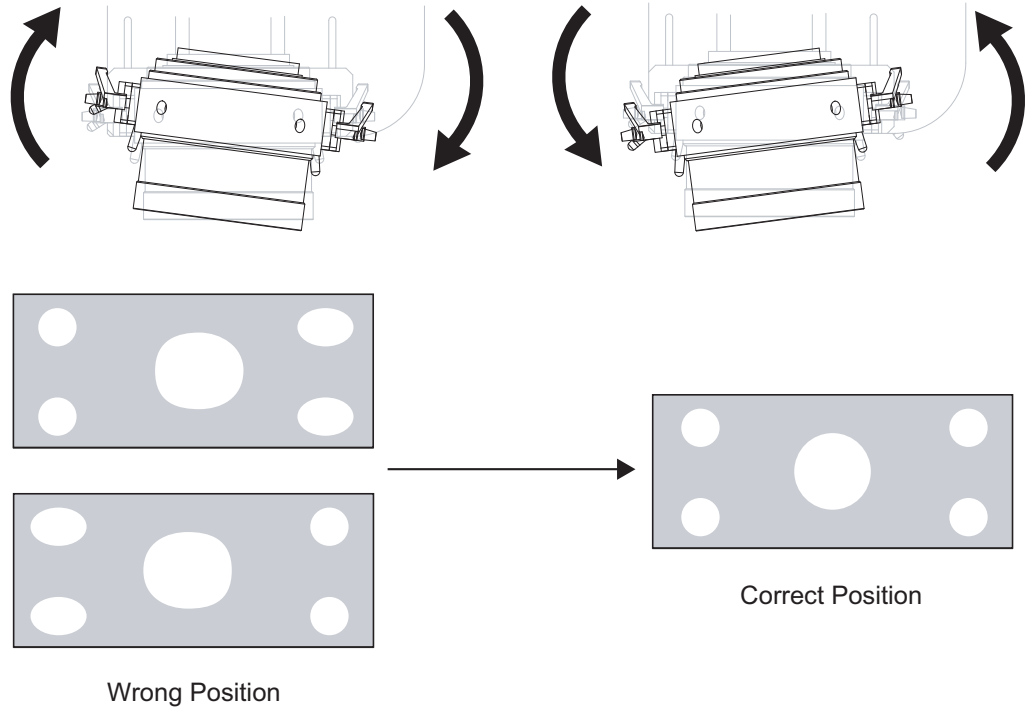

Once the proper lens angle has been set, firmly tighten the Yaw/X-Adjustment Levers to secure the lens in place.

Adjusting the Geometry:

1. Input an anamorphic cross-hatch test pattern to the projector.
2. Unscrew the Anamorphic Lens just enough to allow it to rotate freely.
3. Grasp the lens by the center ring and rotate the lens until the image is properly anamorphic:

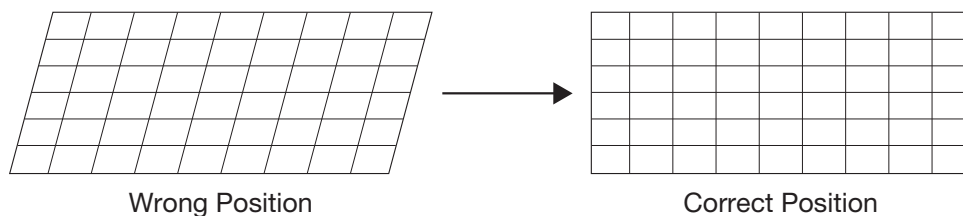

4. When the image geometry appears correct, tighten the Anamorphic Lens Set Screw (item #10) to secure the lens in place. (When viewed from the front, the rear opening on the anamorphic lens should appear as a tall, narrow oval.)

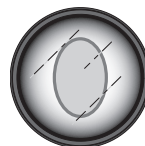

Focus: Finally, rotate the Focus Ring on the anamorphic lens to fine-tune the optical focus.



Notes:

To display the Main Menu, press the **MENU** button on the remote control (Figure 2-5), VHD Controller front panel (Figure 2-3) or projector rear panel (Figure 2-2).

To select a menu item, use the ▲ and ▼ buttons on the remote control, VHD Controller front panel or projector rear panel to highlight it. Then, to confirm your selection, press **ENTER** on the remote control (or **SELECT** on the VHD Controller front panel or projector rear panel).

The Vision 120 OSD menus are arranged hierarchically, as shown in Figure 4-1. Depending on the selected input source and signal characteristics, some menu options may not be available.

4.1 Using the On-Screen Menus

| | |
|-----------------------------------|---|
| Input Source | Composite |
| | S-Video |
| | Component RCA (HD1) |
| | Component BNC (HD2) |
| | Component PC (HD3) |
| | RGB RCA (HD1) |
| | RGB BNC (HD2) |
| | RGB PC (HD3) |
| | HDMI 1 |
| | HDMI 2 |
| Aspect Ratio | 16:9 |
| | 4:3 |
| | Letterbox |
| | IntelliWide |
| | Cinema |
| | IntelliWide 2.35 |
| Picture | Brightness |
| | Contrast |
| | Color |
| | Tint |
| | Sharpness |
| Input Position | Left/Right |
| | Up/Down |
| | Width |
| | Height |
| | Overscan |
| | Phase (RGB/Component signals only) |
| Memory Presets | Recall ISF Night |
| | Recall ISF Day |
| | Recall/Save Custom 1 |
| | Recall/Save THX |
| | Reset Custom 1 and THX to Factory Default |
| Information (read-only) | Resolution |
| | Firmware Versions |
| | OSD Version |

Note: IntelliWide 2.35 is available only on Vision 120 projectors equipped with the CineWide option (secondary anamorphic lens).

| | | |
|-----------------------|-------------------------------------|------------|
| Calibration | ISF Night - Display Color | Gain |
| | | Offset |
| | | Gamma |
| | | Lamp Power |
| | ISF Night - Input Image | Color Temp |
| | | Brightness |
| | | Contrast |
| | | Color |
| | ISF Night - Input Color | Tint |
| | | Sharpness |
| | | Gain |
| | | Offset |
| | ISF Day - Display Color | Gamma |
| | | Lamp Power |
| | | Color Temp |
| Brightness | | |
| ISF Day - Input Image | Contrast | |
| | Color | |
| | Tint | |
| | Sharpness | |
| ISF Day - Input Color | Gain | |
| | Offset | |
| | Chroma Delay | |
| | Noise Filter | |
| Save ISF Settings | Back / Confirm | |
| Output Shift | Left/Right | |
| | Up/Down | |
| | Width | |
| | Height | |
| Splash Timer | 5 ... 60 sec. | |
| OSD Position | Horiz. / Vert. (0, 1, 2 ... 100) | |

| | | | | |
|----------------------------------|----------------------------|--|--|-------|
| Service | Test Video | Horizontal Ramp | | |
| | | Vertical Ramp | | |
| | | Color Bars 1 | | |
| | | Color Bars 2 | | |
| | Display Device - Configure | Installation | Picture Orientation: Floor Front Ceiling Front Floor Rear Ceiling Rear | |
| | | | Lens | Focus |
| | | | | Zoom |
| | | | | Shift |
| | | Lamp Info (read-only) | Hours in use etc. | |
| | Diagnostic | White, Red, Green, Blue, Yellow, Cyan, Magenta | | |
| | HD Format | HD 1 (RCA) | COMP or RGB | |
| | | HD 2 (BNC) | | |
| | | HD 3 (PC) | | |
| | Triggers | I / II / III (1 / 2 / 3) | | |
| | Miscellaneous | Language | English, Français, Deutsch, Español or Italiano | |
| OSD Timer | | 0 or 5 ... 60 sec. | | |
| Film Mode (SD sources only) | | On / Off | | |
| CUE (Chroma Upsampling Error) | | On / Off | | |
| Motion Threshold | | 0, 1, 2 ... 15 | | |
| Altitude | | Normal or High | | |
| System Reset | | | | |
| Restore Saved Settings | | | | |

Figure 4-1. VHD Controller OSD Menu Structure for Vision 120

The Main Menu is the starting point for accessing all projector functions.

(The Calibration and Service menus are hidden and not accessible until you enter a passcode.)

◀ **Main Menu**

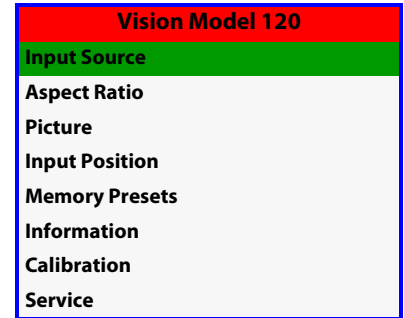

From the Main Menu, select Input Source to choose a video signal source.

The active source is indicated by an arrow (>) to its left; in this example, Composite is the active source.

◀ **Input Source**

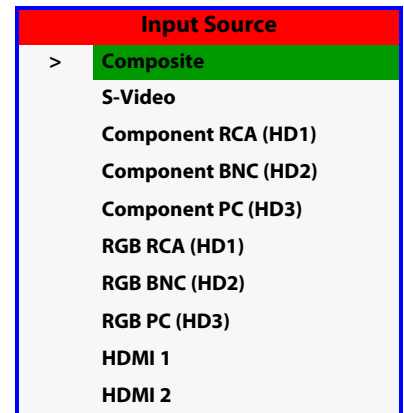

To change the aspect ratio (size and shape) of the projected image, select Aspect Ratio from the Main Menu and press **ENTER** or **SELECT**. Select the appropriate aspect ratio for your screen size and the type of program material being viewed; refer to Table 4-1.

The currently-selected aspect ratio is indicated by a "☒" to its left; in this example, 16:9 is selected.

◀ **Aspect Ratio**

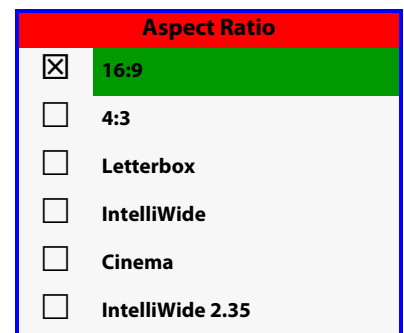

Note

The aspect ratio selection is automatically saved for each input and resolution.

Table 4-1. Aspect Ratio Settings





| Aspect Ratio | Remote Control Key | Description | |
|--------------|--------------------|--|--|
| 16:9 | 16:9 |   | <p>Select 16:9 to view 16:9 DVDs and HDTV programs in their native aspect ratio.</p> <p>4:3 images are stretched horizontally to fit a 16:9 screen.</p> |
| 4:3 | 4:3 |  | <p>Standard 4:3 scales the input signal to fit in the center of the 16:9 screen. 4:3 is the aspect ratio used by computer monitors, standard television programming and most VHS video cassettes.</p> |
| Letterbox | LBOX |  | <p>Letterbox mode scales (zooms in on) a 4:3 image linearly (by the same amount on all sides) to fill a 16:9 display. Letterbox is best suited for viewing LaserDisc movies or non-anamorphic DVDs on a 16:9 screen.</p> |
| IntelliWide | IWIDE |    | <p>IntelliWide scales a 4:3 image NON-linearly (more on the sides than in the center) to fit a 16:9 screen.</p> <p>On a 2.35:1 screen, the image is centered between black bars on either side.</p> |

Table 4-1. Aspect Ratio Settings (continued)

| Aspect Ratio | Remote Control Key | Description | |
|------------------|--------------------|--|--|
| Cinema | CINEMA |  <p>2.35:1 Image on 16:9 Screen (Cinema aspect ratio / no CineWide)</p>  <p>2.35:1 Image on 2.35:1 Screen (Cinema aspect ratio / CineWide)</p> | <p>Select Cinema to view 2.35 source material in its native aspect ratio.</p> <p>With a 16:9 screen and a non-CineWide projector (no anamorphic lens), the upper and lower portions of the screen are masked, but the geometry of the active image area is unchanged.</p> <p>With a 2.35:1 screen and a CineWide-equipped projector, the VHD Controller scales the 2.35:1 image so that the active image area fills the 16:9 chip surface, eliminating the black bars. The secondary, anamorphic lens then restores the proper geometry to the 2.35:1 image.</p> |
| IntelliWide 2.35 | IWIDE 2.35 |  <p>16:9 Image on 2.35:1 Screen</p>  <p>16:9 Image on 2.35:1 Screen with Intelliwide 2.35</p> | <p>A 16:9 image is scaled NON-linearly (more on the sides than in the center) to fit a 2.35:1 screen.</p> <p>IntelliWide 2.35 is available only on the Vision 120/CineWide.</p> |

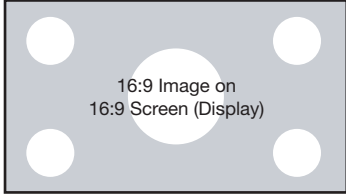
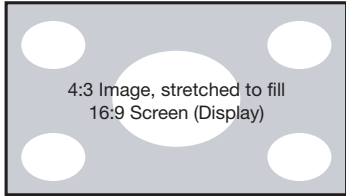
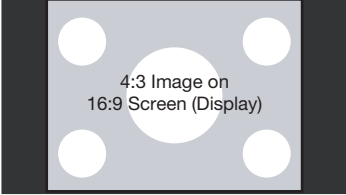
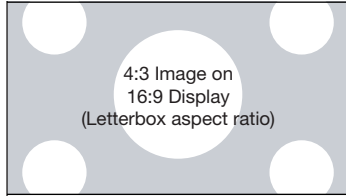
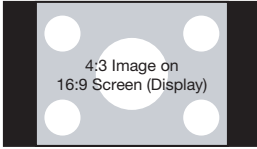
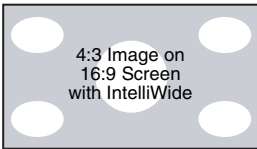
Use the controls in the Picture Menu to calibrate your Vision 120 for optimum picture quality.

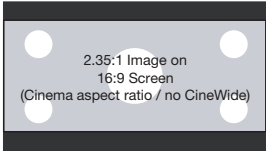
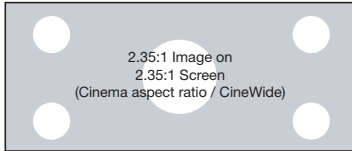
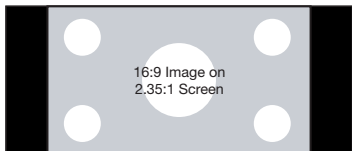
The Vision 120 has been designed to incorporate setup and calibration standards established by the Imaging Science Foundation (ISF). The ISF has developed carefully crafted, industry-recognized standards for optimal video performance and has implemented a training program for technicians and installers to use these standards to obtain optimal picture quality from Vidikron video display devices. Accordingly, Vidikron recommends that setup and calibration be performed by an ISF certified installation technician.

All signal types require separate processing. Therefore, you need to calibrate each VHD Controller input separately.

◀ **Picture**

| Picture | |
|------------|--|
| Brightness | |
| Contrast | |
| Color | |
| Tint | |
| Sharpness | |



Note

When you change a picture quality setting, save the change to a preset afterwards. Otherwise, the change will be lost when a different input is selected. (Picture quality settings are saved for each input separately.) For information about saving settings, refer to **Memory Presets** on page 58.

Although it may be possible to obtain satisfactory picture quality using the naked eye and regular program material, Vidikron recommends using the following calibration tools for best results:

- External test pattern source – Ovation Multimedia, Digital Video Essentials or AVIA test DVD or equivalent.
- A blue filter (provided with many test DVDs), for color level and tint adjustments.

Connect your test pattern source to the input that you are calibrating and proceed as follows.

Perform the adjustments in the order listed here.

Brightness: On your external test pattern source, select a PLUGE pattern. (PLUGE is an acronym for “Picture Line-Up Generation Equipment.”) Figure 4-2 shows a typical PLUGE pattern.

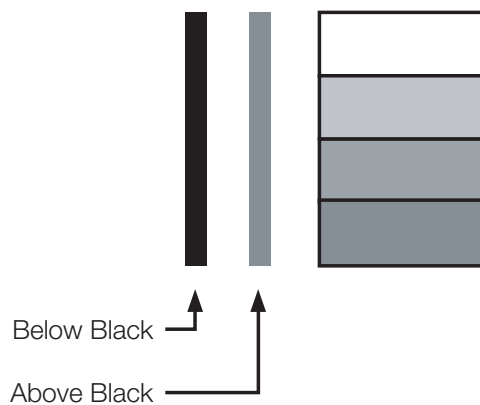

Figure 4-2. Typical PLUGE Pattern for Adjusting Brightness

PLUGE patterns vary but generally consist of some combination of black, white and gray areas against a black background. The example above includes two vertical bars and four shaded boxes.

Select Brightness from the Picture menu and press **ENTER** or **SELECT**. Adjust the brightness so that:

- The darkest black bars disappear into the background.
- The dark gray areas are barely visible.
- The lighter gray areas are clearly visible.
- The white areas are a comfortable level of true white.
- The image contains only black, gray and white (no color).

Contrast: On your external test pattern source, select a stepped, gray-bar pattern like the one shown in Figure 4-3.

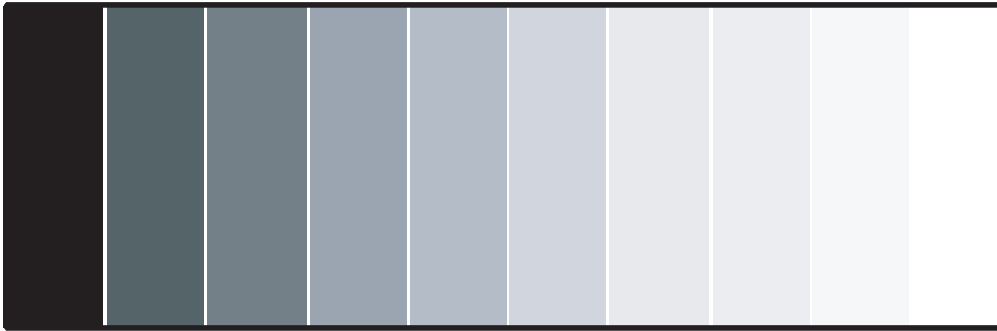

Figure 4-3. Typical Gray Bar Pattern for Adjusting Contrast

Select Contrast and press **ENTER** or **SELECT**. Adjust the contrast to a point just below which the white rectangle starts to increase in size.



Note

Brightness and contrast controls are interactive. A change to one may require a subtle change to the other in order to achieve the optimum setting.

Color Saturation: On your external test pattern source, select a color bar pattern like the one shown in Figure 4-4.

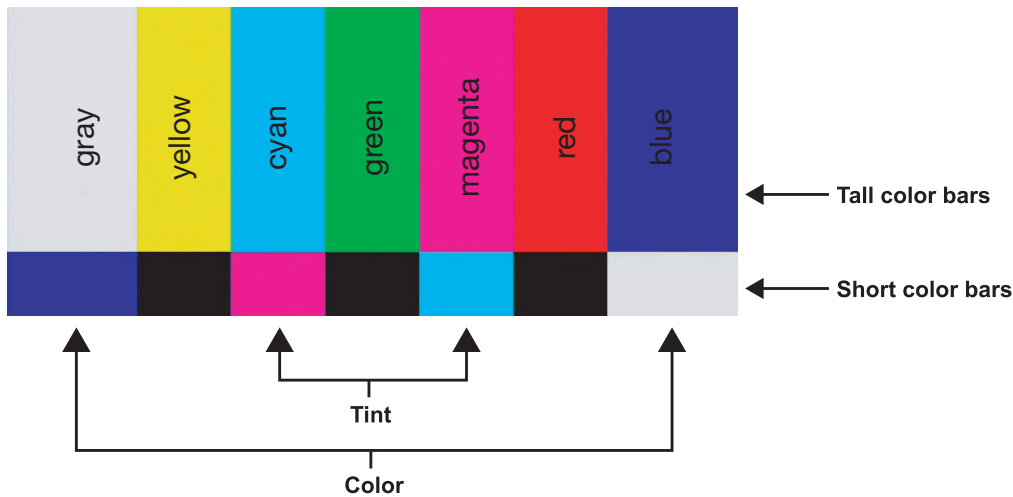
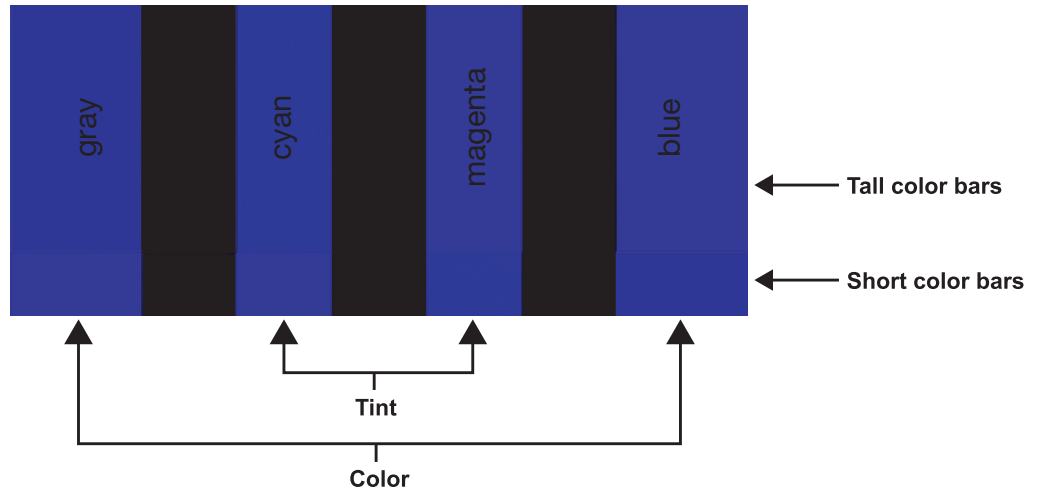

Figure 4-4. Typical Color Bar Pattern for Adjusting Color Saturation and Tint

Select Color and press **ENTER** or **SELECT**. While looking at the color bar pattern through a blue filter, adjust the color saturation level until the outermost (gray and blue) color bars appear to be a single shade of blue:



Tint: Tint or “hue” is essentially the ratio of red to green in the color portion of the image. When tint is decreased, the image appears redder; when it is increased the image appears greener. To set the tint, select Tint and press **ENTER** or **SELECT**. While looking at the color bar pattern through a blue filter, adjust the tint level until the cyan and magenta color bars (on either side of the green bar) appear to be a single shade of blue.



Note

Like the brightness and contrast controls, the color and tint controls are interactive. A change to one may require a subtle change to the other in order to achieve the optimum setting.

Sharpness: “Sharpness” is the amount of high-frequency detail in the image. To adjust sharpness, select Sharpness from the Picture menu and press **ENTER** or **SELECT**. On your external test pattern source, select a pattern like the one shown in Figure 4-5. Adjust as needed, looking for white edges around the transitions from black to gray and differently-sized lines in the “sweep” patterns at the top and bottom. Lower the sharpness setting to eliminate them.

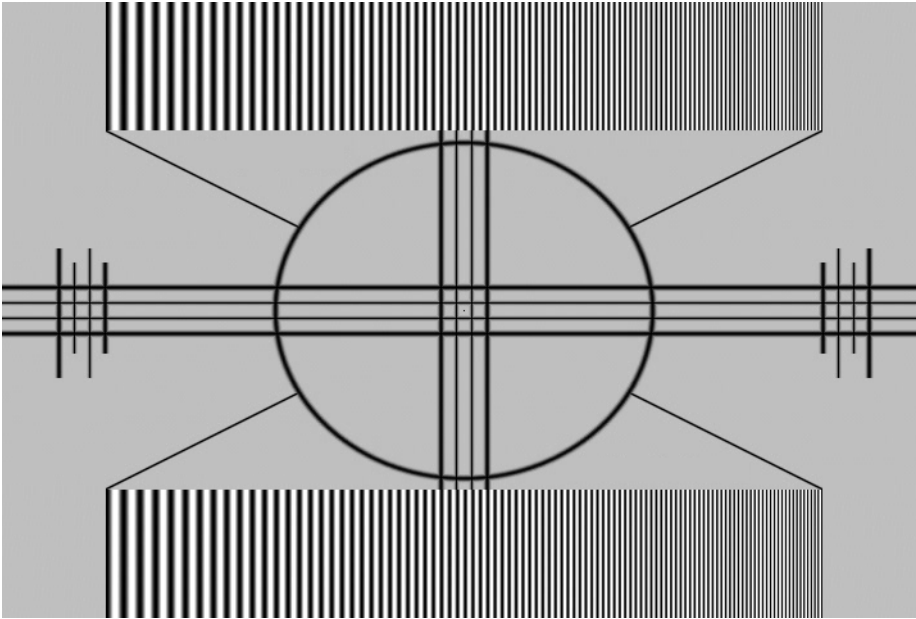

Figure 4-5. Typical Test Pattern for Adjusting Sharpness

Use the controls in the Input Position Menu to fine-tune the aspect ratio and image position for the current source.

◀ **Input Position**



Note

The input position settings are automatically saved for each input and resolution.

Left/Right: Select Left/Right from the Input Position menu to shift the projected image horizontally. Press ▶ to shift the image to the right; press ◀ to shift it to the left.

Up/Down: Select Up/Down from the Input Position menu to shift the projected image vertically. Press ▶ to shift the image upward; press ◀ to shift it downward.

Width: Select Width from the Input Position menu to change the projected image width. Press ▶ to increase the width; press ◀ to decrease it.

Height: Select Height from the Input Position menu to change the projected image height. Press ▶ to increase the height; press ◀ to decrease it.

| Input Position |
|----------------|
| Left/Right |
| Up/Down |
| Width |
| Height |
| Overscan |
| Phase |

Overscan: Image Overscan pushes the outside edge of the active picture area of the video signal out beyond the edge of the display area.

Some television programs are produced based on the assumption that older television sets may not display the outer edges of the broadcast picture area. Over scan effectively trims away these inactive, outer edges and enlarges the remaining portion of the image to fill the display area.

Select from 1% to 10% of Overscan, as desired.

For HDTV, DVDs and other video sources, Overscan is generally not necessary or desirable.

Phase: Adjust the phase if the image from an RGB or Component source shows shimmer or “noise.” Pixel phase adjusts the phase of the pixel sampling clock relative to the incoming signal. The effect of this control is similar to that of a tracking control on a VCR.

For best results, use a good test pattern such as a smooth gray consisting of a clear pattern of black and white pixels, or a similar “half on, half off” graphic image. (You may find that you can stabilize the image at more than one point. Use either setting in this case.)

Memory Presets ➤

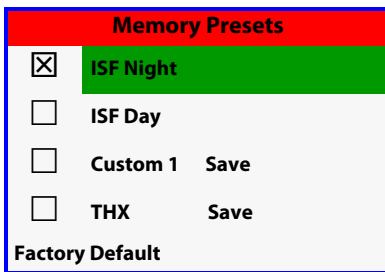

For each input, the Vision 120 lets you save image quality settings as presets that you can recall at a later time. You can create up to four presets per input and resolution. Use the ISF Presets menu to recall saved image presets, or to save image settings in the “Custom 1” or “THX” memory location. The currently-selected preset is indicated by a “☒” to its left; in the example shown here, ISF Night is selected.

You should save changes to any of the following settings to a preset; otherwise they will be lost when a new input source or resolution is selected:

- Brightness
- Contrast
- Color saturation
- Tint
- Sharpness

To reset the Custom 1 and THX image presets to their factory defaults, select Factory Default and press **ENTER** or **SELECT**.

Information ➤

| Information | |
|-------------|--------------|
| Resolution | 1280x768@60 |
| CB Firmware | 0.31 (T32) |
| CB FPGA | rxrev018.sxf |
| SB Firmware | D05 |
| SB FPGA | 0.25 |
| Scaler | 2.5 |
| OSD | E024 |

Select Information from the Main Menu to display information about the current input signal (resolution, frequency, type et cetera) and installed firmware versions. Should you ever need to contact Vidikron Technical Support, this information will help them answer your questions or resolve product performance issues.

Use the Calibration menu to perform advanced picture quality adjustments. **This menu should be used by ISF-certified technicians only.**



Note

You must enter a passcode to access the Calibration menu.

To recall the ISF Night or ISF Day settings, select “ISF Night” or “ISF Day” from the ISF Presets menu (see page 58) or use the corresponding buttons on the remote control.

ISF Night - Display Color: Use the Display Color settings to adjust the color balance at the projector output. These settings are saved independently for each input.

- **Gain:** Use the Gain controls to correct color imbalances in the bright areas of the image. A good way to do this is to use a test pattern consisting mostly of solid white areas, such as an 80 IRE “window” pattern. If the white areas contain traces of red (Pr), green (Y) or blue (Pr), decrease the Gain for that color.
- **Offset:** Use the Offset controls in the White Balance sub-menu to correct color imbalances in the dark areas of the image. A good way to do this is to use a test pattern consisting mostly of dark gray areas, such as a 30 IRE “window” pattern. If the gray areas contain traces of red (Pr), green (Y) or blue (Pr), decrease the Offset for that color.
- **Gamma:** “Gamma” determines how gray shades are displayed between minimum input (black) and maximum input (white) for all signals. A good gamma setting helps to optimize blacks and whites while ensuring smooth transitions for the “in-between” values utilized in other grays. Unlike “Brightness” and “Contrast” controls, the overall tone of your images can be lightened or darkened without changing the extremes and all images will be more vibrant while still showing good detail in dark areas.

In all but the most unusual situations, the appropriate “Color Temp” selection (see below) will produce accurate colors and a satisfying contrast level. However, it is sometimes necessary to adjust the red, blue and green gamma curves individually. To do this, select Gamma from the Display Color sub-menu and use the left- and right-arrow buttons to manipulate the on-screen slidebars.

- **Lamp Power:** Select Lamp Power from the Display Color menu to adjust the lamp output level. You can choose to run the lamp as bright as possible (300W; this is the default setting) or you can choose the lower (250W) setting. Generally, lower lamp output prolongs the life of the lamp, but decreases brightness.
- **Color Temp:** Select Color Temp from the Display Color menu to adjust the color temperature. The default setting is appropriate for most situations. Higher settings produce a “bluer” picture.

ISF Night - Input Image: The Input Image controls are similar to those in the Picture menu, but are accessible only by entering the Calibration menu passcode. This makes it possible to restore the picture quality settings to what they were when the projector was installed, simply by recalling the “ISF Night” preset.

◀ **Calibration**

| |
|----------------------|
| Calibration |
| ISF Night |
| Display Color |
| Input Image |
| Input Color |
| ISF Day |
| Display Color |
| Input Image |
| Input Color |
| Save ISF Settings |
| Output Shift |
| Splash Timer |
| OSD Position |

ISF Night - Input Color: The Input Color controls are similar to those in the Display Color menu (see above), but adjust the color balance of the incoming signal. These settings are also saved independently for each input.

- **Gain/Offset:** Refer to *ISF Night - Display Color*, above.
- **Chroma Delay:** use the Chroma Delay control to correct a mis-aligned image from a Composite, S-Video or Component video source. Chroma delay in an image causes color shifts to occur to the left of the vertical edge transitions, producing artificial shadows or a “halo” effect. If necessary, adjust this setting to eliminate them.
- **Noise Filter:** To apply noise filtering to the input signal, select Noise Filter from the Input Color menu. The Noise Filter is useful for clearing up noisy images from 480i video sources.

Use the left- or right-arrow buttons to select the desired amount of noise reduction, keeping in mind that higher settings (which reduce high frequencies) may also “soften” the image.

ISF Day - Display Color: Refer to *ISF Night - Display Color*.

ISF Day - Input Image: Refer to *ISF Night - Input Image*.

ISF Day - Input Color: Refer to *ISF Night - Input Color*.

Save ISF Settings: Whenever you make a change to the ISF settings, you should always save it. Select Save ISF Settings from the ISF Calibration menu to do this. In the event you ever have to perform a System Reset, you can restore the saved ISF settings by selecting Restore Saved Settings in the Service menu. (System Reset and Restore Saved Settings are described on page 62.)

Output Shift: The controls in the Output Shift menu are similar to those in the Input Position menu, except that they change the characteristics of the output signal. These settings are saved independently **for each aspect ratio**.

Splash Timer: Select Splash Timer from the Calibration menu to set the amount of time the Vidikron/ISF logo “splash” screen appears when you turn on the projector. The range is from 5 to 60 seconds, in one-second increments.

OSD Position: To adjust the position of the OSD, select OSD Position from the Calibration menu and press **ENTER** (or **SELECT**).

Press ▲ or ▼ to select “Hor.” or “Ver.” Then, press ◀ or ▶ change the position.

Use the Service menu to access advanced projector configuration settings. **This menu should be used by ISF-certified technicians only.**

◀ **Service**



Note

You must enter a passcode to access the Service menu.

Test Video: Select Test Video from the Service Menu to access the internal test patterns on the Vision 120. Four patterns are available: Horizontal Ramp, Vertical Ramp, Color Bars 1 (solid bars) and Color Bars 2 (SMPTE “checkerboard” pattern).

Press **MENU** to exit test pattern mode.

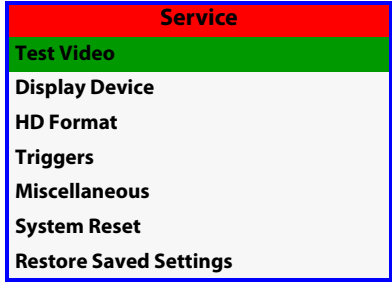

Tip

*You can also use the **PATTERN** button on the projector rear panel or VHD Controller front panel to enter and exit test pattern mode.*

Display Device: The options in the Display Device menu allow you to change the picture orientation and perform lens adjustments.

- **Installation:** Select Installation from the Display Device menu to change the picture orientation to suit the method of installation (Floor Front, Floor Rear, Ceiling Front or Ceiling Rear).
- **Lens:** Select Lens from the Display Device menu to access the motorized lens controls. Refer to **Primary Lens Adjustments** on page 41.
- **Lamp Info:** Select Lamp Info from the Display Device menu to obtain information about the currently-installed lamp: its serial number, number of “strikes” (attempts to ignite) and number of hours in use.
- **Diagnostic:** Select Diagnostic from the Display Device menu, then select Red, Green, Blue, Yellow, Cyan or Magenta to display only that color (simulating a filter of that color). This can be useful for calibration or measurement purposes.

To restore the normal picture (all colors), select **White**.

HD Format: Select HD Format from the Service menu to choose the default color space for the source signals on the HD1, HD2 and HD3 inputs. Select COMP (component) or RGB. The VHD Controller assumes this color space when you “direct-select” an HD input using the left-arrow and right-arrow (◀ or ▶) buttons on the projector rear panel or VHD Controller front panel, or the **HD1**, **HD2** or **HD3** buttons on the remote control unit.

You can override this setting by using the OSD to select an HD input (refer to **Input Source** on page 51). For example, if you select COMP for HD2 here and the input signal changes to RGB, select “RGB BNC” from the Input Source menu to enable the Vision 120 to properly display that signal.

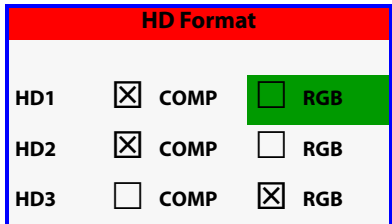

Note

*When you change the default color space for an HD input, it takes effect the **next** time you select that input (not immediately).*

Triggers: Select Triggers from the Service menu to configure the 12-volt trigger outputs. You can assign one or more trigger outputs to each aspect ratio. Those triggers are then activated by selecting that aspect ratio.

If your projector is equipped with the Vidikron CineWide with AutoScope system, assign at least one trigger output (the same one to which the lens motor is connected) to the Cinema and IntelliWide 2.35 aspect ratios.

Miscellaneous: Select Miscellaneous from the Service menu to set the following options:

- **Language:** Select Language from the Miscellaneous menu and press the up- or down-arrows to select the OSD Language (English, Français, Deutsch, Español or Italiano).
- **OSD Timer:** Select OSD Timer from the Miscellaneous menu to set the OSD Timer, which controls how long the menus remain on-screen after selecting them. Select from 5 to 60 seconds, in one-second increments. Or, set the timer to 0 (disabled) if you want the menus to remain on-screen indefinitely.
- **Film Mode:** Use Film Mode to smooth out moving images from interlaced, standard-definition (SD) sources. In most cases, the Vision 120 detects the proper “pull-down” rate and vertical frequency. However, if your source is jittery and/or tearing you may wish to enable Film Mode (ON) to ensure stable processing for that source.
- **CUE (Chroma Upsampling Error) Correction:** Some DVD players use MPEG decoders that do not correctly “upsample” the 4:2:0 format chroma information on the DVD to the 4:2:2 or 4:4:4 format required by the video encoder of the display device.

This so-called “chroma bug” sometimes causes streaky or spiky horizontal lines running through the chroma channel. It is most noticeable in static, interlaced scenes and on diagonal edges (especially red ones). Set CUE to On to correct this issue.

- **Motion Threshold:** The Motion Threshold determines the difference between a pixel and its corresponding value in the previous field or frame that must be exceeded for the pixel to be considered moving.

Increase the Motion Threshold if the image appears excessively noisy or if moving objects appear blurred. Decrease it to reduce or eliminate artifacts caused by deinterlacing errors.

- **Altitude:** Select Altitude from the Miscellaneous menu to control the operation of the projector’s cooling fan.

In most cases, the default setting (Normal) will maintain the correct operating temperature. If the lamp frequently turns off due to overheating, or in certain high-altitude operating environments, you may need to change this setting to High.

System Reset: To reset ALL projector and controller settings (including image settings) back to their factory defaults, choose System Reset from the Service menu.

A confirmation message appears, reminding you to save your settings before you perform the reset, so that you can restore them afterwards. If you have done this, select Confirm to continue with the reset. Otherwise, click Back to cancel.



Caution

This action is not undoable. Proceed with caution! Before you perform a System Reset, save your “Custom” ISF presets (page 58) and ISF Day/Night presets (page 60).

Restore Saved Settings: Following a System Reset, select Restore Saved Settings, then select Yes to apply all previously-saved settings to the projector and VHD Controller.

Maintenance and Troubleshooting

The lamp should be replaced when it reaches the end of its life (typically 2000 hours), or sooner if a noticeable degradation in brightness occurs. When you replace a lamp, you should replace the filters as well.

For lamp or filter replacement, please contact your nearest Vidikron authorized service center or Vidikron dealer. Do not attempt to replace the lamp yourself!

5.1 Lamp Replacement



WARNING

The Vision 120 lamp is under high pressure. Handle it with great care at all times. Lamps may explode if dropped or mishandled.

Never attempt to disassemble the lamp casing or dispose of the lamp casing in any manner other than by returning it to your Vidikron dealer.

If the lamp breaks, leave the area immediately and stay away for at least 30 minutes. Ventilate the room to allow the mercury vapor to disperse.

If you inhale the mercury vapor, see a physician immediately.

1. Turn off the projector and unplug the power cord. Allow the projector to cool down for approximately 45 minutes prior to removing the lamp assembly for replacement.
2. Loosen and remove the rear Lamp Cover screw.



3. Slide the Lamp Cover in the direction of the arrow to remove it.

4. Loosen the two, captive lamp assembly mounting screws using a coin or a large, flat-blade screwdriver.

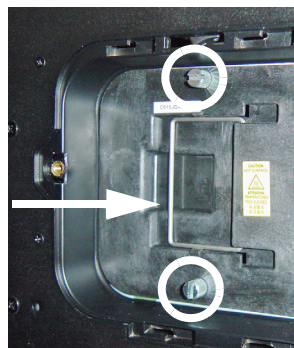

5. Grasp the lamp assembly handle and pull gently, removing the lamp module from the projector housing.

6. Install the new lamp module.
7. Replace the lamp cover and re-tighten all screws.

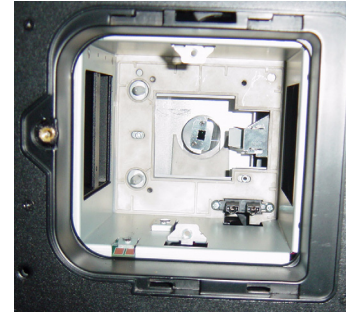

5.2 Filter Replacement

Whenever you replace the lamp – or more often if the projector is installed in an extremely dusty environment – you should also replace the filter located at the right side of the projector.

1. Loosen the two screws holding the filter access panel in place. Then, remove the panel.
2. Pull the filter out of the projector and discard. **Do not reuse filters.**
3. Insert the new filter with the pleats facing in and the foam-covered side facing out.
4. Replace the filter access panel and tighten the screws to secure it.

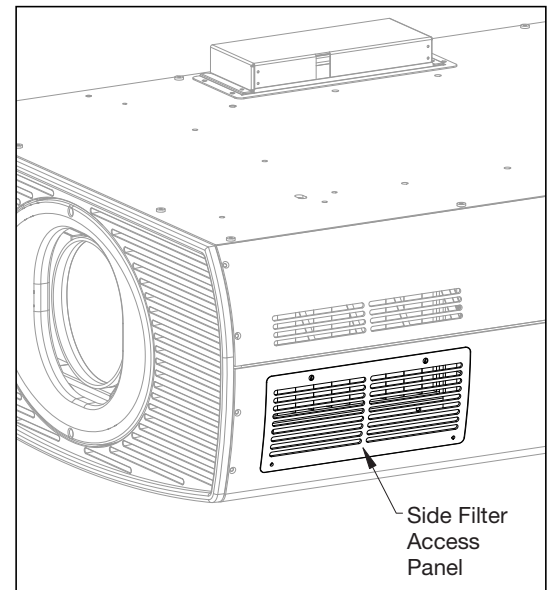

Table 5-1 provides some general guidelines for troubleshooting problems you may encounter with the Vision 120. If the suggested solutions fail to resolve the problem or if you encounter an issue not described here, please contact Vidikron Technical Support.

5.3 Troubleshooting Tips

Table 5-1. Troubleshooting Chart

| Symptom | Possible Cause(s) | Solution |
|--|--|---|
| The projector does not turn on after initial installation. The power LED on the front of the VHD Controller lights red after you press the power button. | <ul style="list-style-type: none"> The VHD Controller is connected to the Vision 120 incorrectly or not at all. The Vision 120 is not plugged in or the AC outlet is not active. | <ul style="list-style-type: none"> Verify the DVI-DL cable connection from the VHD Controller to the Vision 120 (Figure 3-10). Ensure that the Vision 120 is plugged in and that the AC outlet is active. |
| The projector and VHD Controller are both on, but there is no video image on-screen. | <ul style="list-style-type: none"> Incorrect source selection. Source component is not turned on. | <ul style="list-style-type: none"> Select the correct source. Turn on the source. |
| A projected image from a DVD is split or otherwise scrambled. | <ul style="list-style-type: none"> DVD player is set to progressive scan mode. | <ul style="list-style-type: none"> Turn off progressive scan on the DVD player. |
| Image is too bright and/or lacks definition in the bright areas of the image. | <ul style="list-style-type: none"> Contrast is set too high. | <ul style="list-style-type: none"> Lower the contrast setting. |
| Image appears "washed out" and/or dark areas appear too bright. | <ul style="list-style-type: none"> Brightness is set too high. | <ul style="list-style-type: none"> Lower the brightness setting. |
| Colors in the image are swapped; for example, reds appear blue or vice versa. | <ul style="list-style-type: none"> The Red/Pr, Green/Y or Blue/Pb outputs from the source are connected to the wrong inputs on the VHD Controller. | <ul style="list-style-type: none"> Ensure that the source outputs are connected to the correct VHD Controller input. |
| Image geometry is incorrect. | <ul style="list-style-type: none"> Incorrect aspect ratio selection. | <ul style="list-style-type: none"> Select the aspect ratio that best matches the source image and screen size (refer to Table 4-1). |
| The projector will not turn back on after it was powered down, or the image disappears during operation. | <ul style="list-style-type: none"> The projector will not turn on for two minutes after power-down, to protect the lamp. The lamp has failed. | <ul style="list-style-type: none"> Wait two minutes until the STAND-BY LED at the front of the VHD Controller turns orange. Replace the lamp. |

Notes:

To interface the VHD Controller with a home theater automation/control system or a PC running terminal emulation software, connect it to your control system or PC as shown in Figure 3-16. **Use a null-modem cable.**

If you are using a PC to communicate with the VHD Controller:

1. Start a terminal session on your PC using a terminal-emulation program, such as HyperTerminal.
 2. Configure the PC serial port as follows: no parity, 8 data bits, 1 stop bit and no flow control. Set the baud rate to 19200, to match that of the VHD Controller RS-232 port.
 3. Press **<Enter>**. You should see a command prompt (**>**) in the terminal window.
 4. Type a command from among those listed in Table 6-1 and press **<Enter>**.
- Commands are in ASCII format and are not case-sensitive; `on` and `ON` are equivalent.
 - For a command that takes no parameters, type the command followed by a carriage return; for example, to turn on the system, type `ON<Enter>`.
 - For a command that takes a parameter, type the command, one or more spaces and the desired value followed by a carriage return; for example, to switch to the S-Video input, type `SSRC 1<Enter>`.
 - When you enter a valid command, the VHD Controller executes it. When you send an on/off, input selection, aspect ratio or image preset command, the VHD Controller also responds with an acknowledgment on the command line. For example, when you issue the command `SAR 2`, the VHD Controller responds with `Letterbox` on the command line.
 - When you enter a misspelled or otherwise invalid command, the VHD Controller ignores it and responds with `Invalid Command` on the command line.
 - When you send a command followed by values outside the valid range for that command, the VHD Controller ignores it and responds with `Invalid Parameter` on the command line.
 - When the VHD Controller receives an `OFF` command, it will not acknowledge or execute any commands for approximately 90 seconds afterwards. This is to prevent hot re-strikes of the lamp, which can damage it.

6.1 RS-232 Connection and Port Configuration

6.2 Serial Command Syntax

Table 6-1 lists the serial commands supported by the VHD Controller and the responses it sends back to the control system or PC.

Table 6-1. Serial Commands and Responses

| Command | Description | Response |
|---------------------------------|---|---------------------------------------|
| off | Turns projector off | Powering Down |
| on | Turns projector on | Powering Up Genum Init Complete |
| rev | Display system firmware version information: > rev * Vidikron Genum Scaler Board * * Rev 0.28 (T01) 05 Jan 2007 * File Name: Vidikron_Genum.ncd Created: 21 Dec 2006 - 10:42:40 Device: XC3S100EVQ100 | (see description) |
| Input Selection Commands | | |
| SSRC 0 | Selects the Composite video input | Composite |
| SSRC 1 | Selects the S-Video input | S-Video |
| SSRC 2 | Selects the Component RCA (HD1) input | Component RCA |
| SSRC 3 | Selects the Component BNC (HD2) input | Component BNC |
| SSRC 4 | Selects the Component PC (HD3) input | Component PC |
| SSRC 5 | Selects the RGB RCA (HD1) input | RGB RCA |
| SSRC 6 | Selects the RGB BNC (HD2) input | RGB BNC |
| SSRC 7 | Selects the RGB PC (HD3) input | RGB PC |
| SSRC 8 | Selects the HDMI 1 input | HDMI 1 |
| SSRC 9 | Selects the HDMI 2 input | HDMI 2 |
| Aspect Ratio Commands | | |
| SAR 0 | Selects the 16:9 aspect ratio | 16:9 |
| SAR 1 | Selects the 4:3 aspect ratio | 4:3 |
| SAR 2 | Selects the Letterbox aspect ratio | Letterbox |
| SAR 3 | Selects the IntelliWide aspect ratio | IWide |
| SAR 4 | Selects the Cinema aspect ratio | Cinema |
| SAR 5 | Selects the IntelliWide 2.35 aspect ratio | IntelliWide 2.35 |

Table 6-1. Serial Commands and Responses (continued)

| Command | Description | Response |
|--|---|-----------|
| Image Preset Commands | | |
| SISF 0 | Loads "ISF Night" image preset | ISF Night |
| SISF 1 | Loads "ISF Day" image preset | ISF Day |
| SISF 2 | Loads "Custom 1" image preset | Custom 1 |
| SISF 3 | Loads "THX" image preset | THX |
| Menu Navigation Commands | | |
| <p>The following serial commands are meant to emulate buttons on the remote control or VHD Controller front panel. Each button has its own serial command, so effectively it is as if you were using the IR remote only you'll be doing so via serial commands. These commands provide active OSD responses just like the IR remote.</p> | | |
| ENTR | ENTER (or SELECT) button | (none) |
| EXIT | EXIT button | |
| MENU | MENU button | |
| MND | Down-Arrow (▼) button | |
| MNL | Left-Arrow (◀) button | |
| MNR | Right-Arrow (▶) button | |
| MNU | Up-Arrow (▲) button | |
| Picture Adjust Commands | | |
| <p>The following serial commands are meant to emulate the discrete picture adjustment buttons on the remote control unit. Use them in conjunction with MNL and/or MNR to make picture adjustments. For example, to increase Brightness by five increments, send this sequence of commands:</p> <pre> MBR <Enter> MNR <Enter> MNR <Enter> MNR <Enter> MNR <Enter> MNR <Enter> EXIT <Enter> </pre> | | |
| MBR | Adjust Brightness | (none) |
| MCOL | Adjust Color Level | |
| MCON | Adjust Contrast | |
| MTIN | Adjust Tint | |

Notes:

Specifications

Table 7-1 lists the Vision 120 specifications.

Table 7-1. Vision 120 Specifications

| | |
|--|---|
| Projector Type: | Digital Light Processing (DLP), 3-chip, 16:9 DMD |
| Native Resolution: | 1920 x 1080 (16:9) |
| Aspect Ratios: | Refer to Table 7-2 |
| Video Standards: | Refer to Table 7-2 |
| DTV Compatibility: | 480i/576i, 480p, 576p, 1080i 50/60, 720p 50/60, 1080p 24/50/60, 1080psf |
| Scan Frequency: | Horizontal: 15 - 100 kHz Vertical: 28 - 78 Hz |
| Picture Size (16:9 Screen): | Recommended Width: 72 - 120 in. Maximum Width: 250 in. |
| Throw Distance (Factor x Screen Width): | Refer to Table 3-3 |
| Horizontal and Vertical Offset: | Refer to Table 3-4 |
| Lamp: | 300W UHP |
| Estimated Lamp Life: | 2000 hours |
| Input: | DVI-DL (Dual-Link) with HDCP (from VHD Controller) |
| Controls: | Built-in keypad |

7.1 Vision 120 Specifications

Table 7-1. Vision 120 Specifications (continued)**Brightness and Contrast:****Cinema Standards Measurement System (CSMS) Specifications**

- Brightness: 58.3 foot-Lamberts (fL)
- Contrast Ratio: 320:1

These measurements are taken from the projector in a controlled, home theater environment. All measurements are made to ANSI/NAPM IT7.228-1997 specifications using the Photo Research PR-650 SpectraColorimeter and Minolta LS-100 Luminance Meter, Video Essentials test DVD and a 1.3 gain, 72-inch wide screen. The projector is calibrated to a color temperature of 6,500K and has a minimum of 150 hours of usage.

The foot-Lambert (fL) is the unit of measurement used in commercial movie theaters to express image brightness at the screen surface. The Society of Motion Picture and Television Engineers (SMPTE) specifies 16 fL as the target image brightness for film-based projectors using an open gate (without film in the projector). More importantly, today SMPTE specifies 12 fL as the target image brightness in Digital Cinema theaters. The foot-Lambert measurement is dependent on screen size, screen gain and projector light output.

Home Theater Calibration Specifications

- Light Output: 1380 ANSI Lumens
- Contrast Ratio: 320:1

These specifications are obtained by calibrating the projector as described above for CSMS measurements.

Industry-Standard Specifications

- Light Output: 2825 ANSI Lumens
- Contrast Ratio: 4000:1

These are typical projector brightness and contrast specifications found in most companies' sales literature. Vidikron includes these measurements in its literature to allow for direct comparison with other manufacturers' projectors. These measurements are typically taken at 9,000K to 13,000K to get expected performance data when the projector is used in professional, commercial and industrial displays.

Power Requirements:

100 to 240 VAC (auto-sensing), 50/60 Hz, 530 Watts (1808.9 BTUs/hour)

Operating Environment:

41°F to 95°F (5°C to 35°C), 0% to 90% humidity (non-condensing)

Dimensions:

See Figure 7-1

Weight (without lens):

99.21 lbs. (45.00 kg)

Regulatory Approvals:

Complies with FCC Class B, CE, C-Tick, GOST, TUV-GS, cTUV-US

Limited Warranty:

Projector: Two (2) years parts and labor from the date of delivery to the end user.
Lamp: 1000 hours or six (6) months, whichever comes first.

Specifications are subject to change without notice.

Table 7-2 lists the VHD Controller specifications.

Table 7-2. VHD Controller Specifications

| | |
|---|---|
| Aspect Ratios: | 4:3, Letterbox, 16:9, IntelliWide, Cinema, IntelliWide 2.35 |
| Video Standards: | NTSC, NTSC 4.43, PAL B/G/H/I/M/N , SECAM |
| Output Resolution: | 1080p |
| Inputs: | (1) Composite (1) S-Video (1) HD Video, R (Pr), G (Y), B (Pb), H, V - RCA connectors (1) HD Video/Computer, R (Pr), G (Y), B (Pb), H, V - BNCs (1) HD Video/Computer, R (Pr), G (Y), B (Pb), H, V - 15-pin D-Sub connector (2) HDMI with HDCP |
| Output: | DVI-DL (Dual-Link) with HDCP |
| Control Options: | - Discrete infrared remote - Serial commands via RS-232 interface - Front-panel controls |
| RS-232 Communication Parameters: | 19200 bps, no parity, 8 data bits, 1 stop bit, no flow control |
| Trigger Outputs: | (3) +12 VDC, each rated at 750 mA and thermal fuse-protected |
| Bandwidth: | 150 Mega Samples per Second (MSPS) |
| Power Requirements: | 100 to 240 VAC (auto-sensing), 50/60 Hz, 160 Watts (546.1 BTUs/hour) |
| Operating Environment: | 41°F to 95°F (5°C to 35°C), 0% to 90% humidity (non-condensing) |
| Dimensions: | Width = 17.50 inches (444.5 mm) Depth = 11.19 inches (284.1 mm) Height = 3.75 inches (95.3 mm) |
| Weight: | 13.0 lbs. (5.90 kg) |
| Regulatory Approvals: | Complies with FCC, CE C-Tick |
| Limited Warranty: | Two (2) years parts and labor from the date of delivery to the end user. |

Specifications are subject to change without notice.

7.2 VHD Controller Specifications

7.3 Vision 120 Dimensions

Figure 7-1 shows the Vision 120 dimensions (all dimensions are in inches).

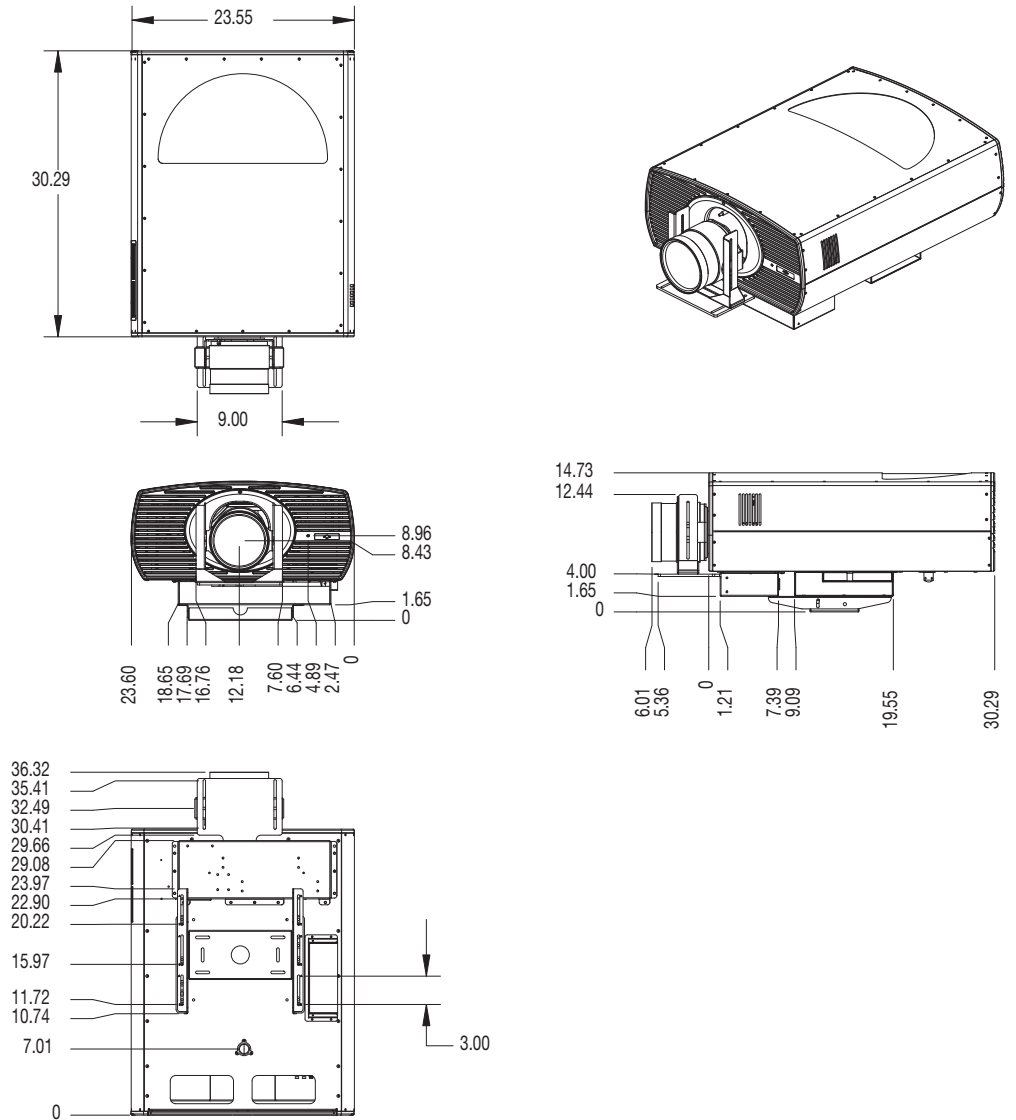

Figure 7-1. Vision 120/CineWide with AutoScope Dimensions

Table 7-3 lists the signal types supported by each input on the Vision 120.

7.4 Supported Timings

Table 7-3. Supported Signal Timings by Input

| Format | Resolution | Refresh Rate (Hz) | Horizontal Frequency (kHz) | Pixel Frequency (MHz) | Supported? (√ = Yes, – = No) | | | |
|-----------|------------|-------------------|----------------------------|-----------------------|------------------------------|-----------|------------------|-------------------|
| | | | | | HD 1/HD 2/HD 3 | | HDMI 1 HDMI 2 | Composite S-Video |
| | | | | | RGBHV | Component | | |
| 640x480 | 640x480 | 60.00 | 31.469 | 25.175 | √ | – | √ | – |
| | | 72.00 | 37.861 | 31.500 | √ | – | √ | – |
| | | 75.00 | 37.500 | 31.500 | √ | – | √ | – |
| | | 85.00 | 43.269 | 36.000 | √ | – | √ | – |
| 800x600 | 800x600 | 60.00 | 37.879 | 40.000 | √ | – | √ | – |
| | | 72.00 | 48.077 | 50.000 | √ | – | √ | – |
| | | 75.00 | 46.875 | 49.500 | √ | – | √ | – |
| | | 85.00 | 53.674 | 56.250 | √ | – | √ | – |
| 1024x768 | 1024x768 | 60.00 | 48.363 | 65.000 | √ | – | √ | – |
| | | 70.00 | 56.476 | 75.000 | √ | – | √ | – |
| | | 75.00 | 60.023 | 78.750 | √ | – | √ | – |
| | | 85.00 | 68.677 | 94.500 | √ | – | √ | – |
| 1152x864 | 1152x864 | 75.00 | 67.500 | 108.000 | √ | – | √ | – |
| 1280x768 | 1280x768 | 60.00 | 47.396 | 68.250 | √ | – | √ | – |
| | | 60.00 | 47.776 | 79.500 | √ | – | √ | – |
| | | 75.00 | 60.289 | 102.250 | √ | – | √ | – |
| | | 85.00 | 68.633 | 117.500 | √ | – | √ | – |
| 1280x960 | 1280x960 | 60.00 | 60.000 | 108.000 | √ | – | √ | – |
| | | 85.00 | 85.938 | 148.500 | √ | – | √ | – |
| 1280x1024 | 1280x1024 | 60.00 | 63.981 | 108.000 | √ | – | √ | – |
| | | 75.00 | 79.976 | 135.000 | √ | – | √ | – |
| | | 85.00 | 91.146 | 157.500 | √ | – | √ | – |
| 1360x768 | 1360x768 | 60.00 | 47.712 | 85.500 | √ | – | √ | – |
| 1400x1050 | 1400x1050 | 60.00 | 64.744 | 101.000 | √ | – | √ | – |
| | | 60.00 | 65.317 | 121.750 | √ | – | √ | – |
| | | 75.00 | 82.278 | 156.000 | √ | – | √ | – |
| 1600x1200 | 1600x1200 | 60.00 | 75.000 | 162.000 | √ | – | √ | – |
| 1920x1200 | 1920x1200 | 60.00 | 74.038 | 154.000 | √ | – | √ | – |

Table 7-3. Supported Signal Timings by Input (continued)

| Format | Resolution | Refresh Rate (Hz) | Horizontal Frequency (kHz) | Pixel Frequency (MHz) | Supported? (√ = Yes, – = No) | | | |
|-----------|------------|-------------------|----------------------------|-----------------------|------------------------------|-----------|------------------|----------------------|
| | | | | | HD 1/HD 2/HD 3 | | HDMI 1 HDMI 2 | Composite S-Video |
| | | | | | RGBHV | Component | | |
| 480/60i | 720x487 | 59.94 | 15.734 | 13.500 | √ | √ | √ | √ |
| 480/60p | 720x483 | 59.94 | 31.469 | 27.000 | √ | √ | √ | – |
| 576/50i | 720x576 | 50.00 | 15.625 | 14.750 | √ | √ | √ | √ |
| 576/50p | 720x576 | 50.00 | 31.250 | 29.000 | √ | √ | √ | – |
| 720/50p | 1280x720 | 50.00 | 37.500 | 75.250 | √ | √ | √ | – |
| 720/60p | 1280x720 | 60.00 | 45.000 | 74.250 | √ | √ | √ | – |
| 1080/50i | 1920x1080 | 50.00 | 28.125/31.250 | 74.250/72.000 | √ | √ | √ | – |
| 1080/60i | 1920x1080 | 59.94/60.00 | 33.716/33.750 | 74.175/74.250 | √ | √ | √ | – |
| 1080/24p | 1920x1080 | 23.98/24.00 | 26.978/27.000 | 74.175/74.250 | √ | √ | √ | – |
| 1080/50p | 1920x1080 | 50.00 | 56.250 | 148.500 | √ | √ | √ | – |
| 1080/60p | 1920x1080 | 59.94/60.00 | 67.433/67.500 | 148.350/148.500 | √ | √ | √ | – |
| NTSC 3.58 | – | 59.94/60.00 | 15.734/15.750 | 3.580 | √ | √ | √ | √ |
| NTSC 4.43 | – | 59.94/60.00 | 15.734/15.750 | 4.430 | √ | √ | √ | √ |
| PAL-B/G | – | 50.00 | 15.625 | 4.430 | √ | √ | √ | √ |
| PAL-M | – | 59.94/60.00 | 15.734/15.750 | 3.580 | √ | √ | √ | √ |
| PAL-N | – | 50.00 | 15.625 | 3.580 | √ | √ | √ | √ |
| PAL-60 | – | 59.94/60.00 | 15.734/15.750 | 4.430 | √ | √ | √ | √ |
| SECAM | – | 50.00 | 13.500 | 4.250/4.410 | – | – | – | √ |

020-0844-00 rev. B
December 2007



Vidikron
2900 Faber Street
Union City, CA 94587
510-324-5900
Fax 510-324-5905
1-888-4-VIDIKRON
www.vidikron.com



SERIAL NUMBER

Free Manuals Download Website

<http://myh66.com>

<http://usermanuals.us>

<http://www.somanuals.com>

<http://www.4manuals.cc>

<http://www.manual-lib.com>

<http://www.404manual.com>

<http://www.luxmanual.com>

<http://aubethermostatmanual.com>

Golf course search by state

<http://golfingnear.com>

Email search by domain

<http://emailbydomain.com>

Auto manuals search

<http://auto.somanuals.com>

TV manuals search

<http://tv.somanuals.com>