

**ViewSonic®**



***WR100***  
***802.11g Wireless Router***

**User Guide**



Copyright © ViewSonic Corporation, 2004. All rights are reserved.

ViewSonic and the three birds logo are registered trademarks of ViewSonic Corporation.

UPnP™ is a trademark of UPnP™ Implementers Corporation (UIC).

The 'Wi-Fi CERTIFIED' logo is a certification mark of the Wi-Fi Alliance.

Broadcom and the 125 High Speed Mode™ logo are trademarks of Broadcom Corporation in the United States and other countries.

Microsoft, Windows, the Microsoft Internet Explorer logo graphic, and the Windows logo are either registered trademarks or trademarks of Microsoft Corporation in the United States and/or other countries.

Corporate names and trademarks are the property of their respective companies.

Disclaimer: ViewSonic Corporation shall not be liable for technical or editorial errors or omissions contained herein; nor for incidental or consequential damages resulting from furnishing this material, or the performance or use of this product.

In the interest of continuing product improvement, ViewSonic Corporation reserves the right to change product specifications without notice. Information in this document may change without notice.

No part of this document may be copied, reproduced, or transmitted by any means, for any purpose without prior written permission from ViewSonic Corporation.

## Product Registration

To meet your future needs and to receive additional product information as it becomes available, register your ViewSonic® product at: [www.viewsonic.com](http://www.viewsonic.com).

### For Your Records

Model Name:	WR100
Model Number:	VS10276
Document Number:	A-WR100-1_CD 08-20-04
Serial Number:	_____
Purchase Date:	_____

# Table of Contents

---

Product Registration.....	i
For Your Records.....	i
<b>Chapter 1: Getting Started</b>	
Overview.....	1
Package Contents .....	3
Safety Notice .....	4
<b>Chapter 2: Product Description</b>	
Front of router.....	5
Back of router .....	6
<b>Chapter 3: Setting up the wireless router</b>	
Step 1 Connect the wireless router.....	8
Step 2 Configure your PC.....	10
For Windows 2000 or XP .....	10
For Windows® 98 or Me .....	13
Step 3 Configure the wireless router .....	16
Security Mode: WEP .....	20
Security Mode: WPA Pre-shared Key .....	22
Security Mode: WPA Radius .....	23
<b>Chapter 4 Advanced Web Management Settings</b>	
Security (Firewall) .....	24
System.....	27
To upgrade the Wireless router's firmware: .....	28

Table of Contents, continued

MAC Cloning .....	29
DHCP Server .....	32
Status.....	34
Advanced Wireless .....	35
Access Filters .....	39
Virtual Server .....	45
Routing Table .....	47

**Appendix**

Specifications.....	51
Troubleshooting .....	52
Compliance Information.....	56
Cleaning & Maintenance.....	59
Customer Support.....	60
Limited Warranty.....	61

# Chapter 1: Getting Started

---

This chapter provides an Overview of the **ViewSonic WR100 Wireless Router**, Package Contents, and Safety Notice.

## Overview

Congratulations on purchasing the **ViewSonic Wireless Router!**

### Freedom of a wireless network

- **Create a wireless network for your home or office**  
Create a local area network (LAN) with the WR100 Wireless Router and share a single high-speed broadband connection, files, printers and other peripherals among all your computers.
- **Robust security keeps your data secure**  
Network Address Translation (NAT) and Stateful Packet Inspection (SPI) firewall ensures your networked data is safe from Internet intruders. Wireless security includes 64-bit/128-bit Wired Equivalency Privacy (WEP), 256-bit Wi-Fi Protected Access™ (WPA) and Medium Access Controller (MAC) address filtering.

- **Supports 125 High Speed Mode™ \***



Transfer data up to 10 times the speed of standard 802.11b wireless networks. Share your files, videos, music and pictures almost instantly with the 125\* high speed mode within your network.

\* The **WR100 Wireless Router** performs at 125 High Speed Mode only with wireless adapters that support this protocol, such as the **ViewSonic WPCC100 Wireless PC Card**. If your wireless adapter does not support this protocol, however, the **WR100 Wireless Router** will still work at standard 802.11g speed.

\* When operating at the highest speeds, the **WR100 Wireless Router** achieves a throughput of up to 34 Mbps, which is the equivalent throughput of a system following 802.11g protocol and operating at a signaling rate of 125 Mbps. This mode requires the same technology from the client devices such as the **ViewSonic WPCC100 PC Card Adapter**.

- **Easy set up**

User-friendly set up wizard on the Network Companion CD makes installation a snap.

# Package Contents

Check to make sure all of the items shown below are included in the package.



Wireless WR100 Router



Network Companion CD

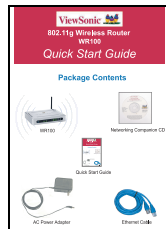

Quick Start Guide



AC Power Adapter



Ethernet LAN Cable  
(6 feet)

For information on optional accessories and products, go to [www.viewsonic.com](http://www.viewsonic.com).

**ViewSonic** Wireless Router

# Safety Notice

To ensure safe operation, following these simply rules:

- Place device in a safe, secure location.
- Read the user guide thoroughly before installing the device.
- The device should only be repaired by authorized and qualified personnel. Do not try to open or repair the device yourself as this voids the warranty.
- Do not place the device in a damp, wet, or humid location like a bathroom.
- Do not expose the device to direct sunlight or other heat sources. The housing and electronic components may be damaged by direct sunlight or heat sources.



# Chapter 2: Product Description

---

This chapter describes the parts of the router on the **Front** and **Back** panels.

## Front of router

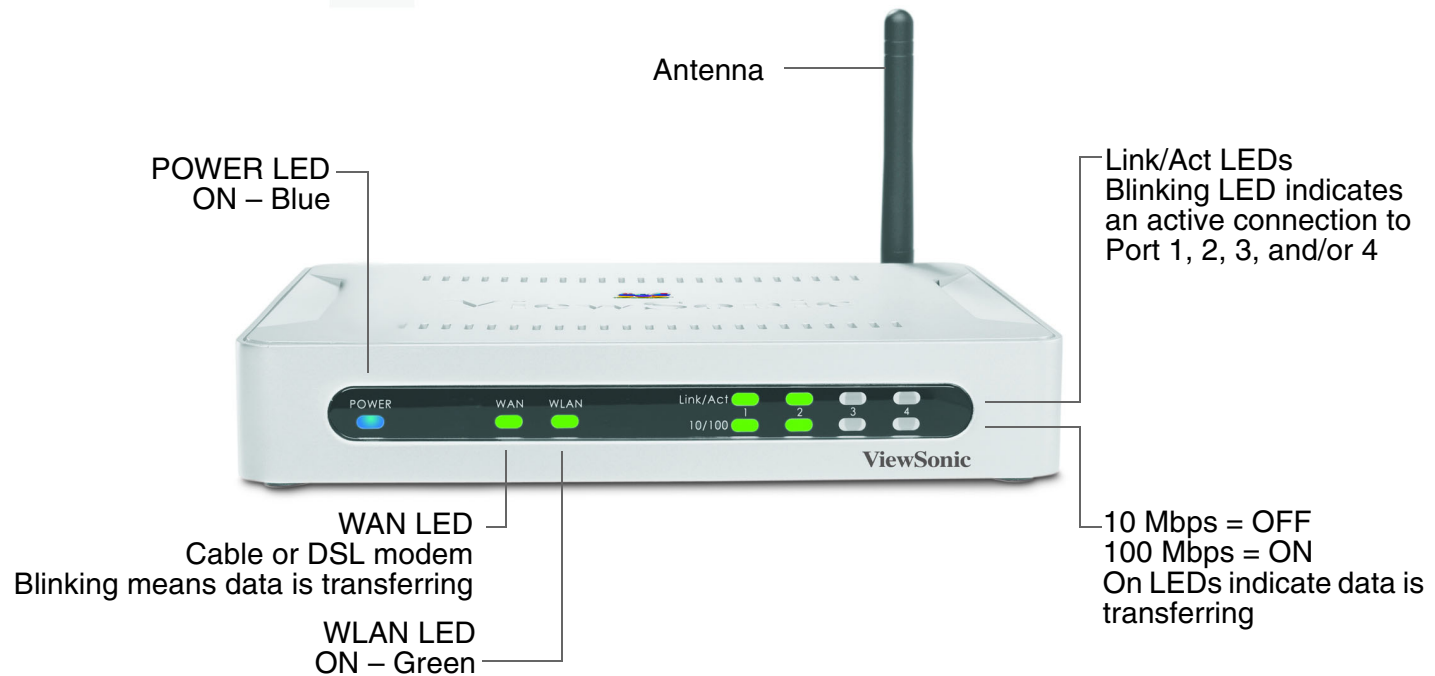

# Back of router

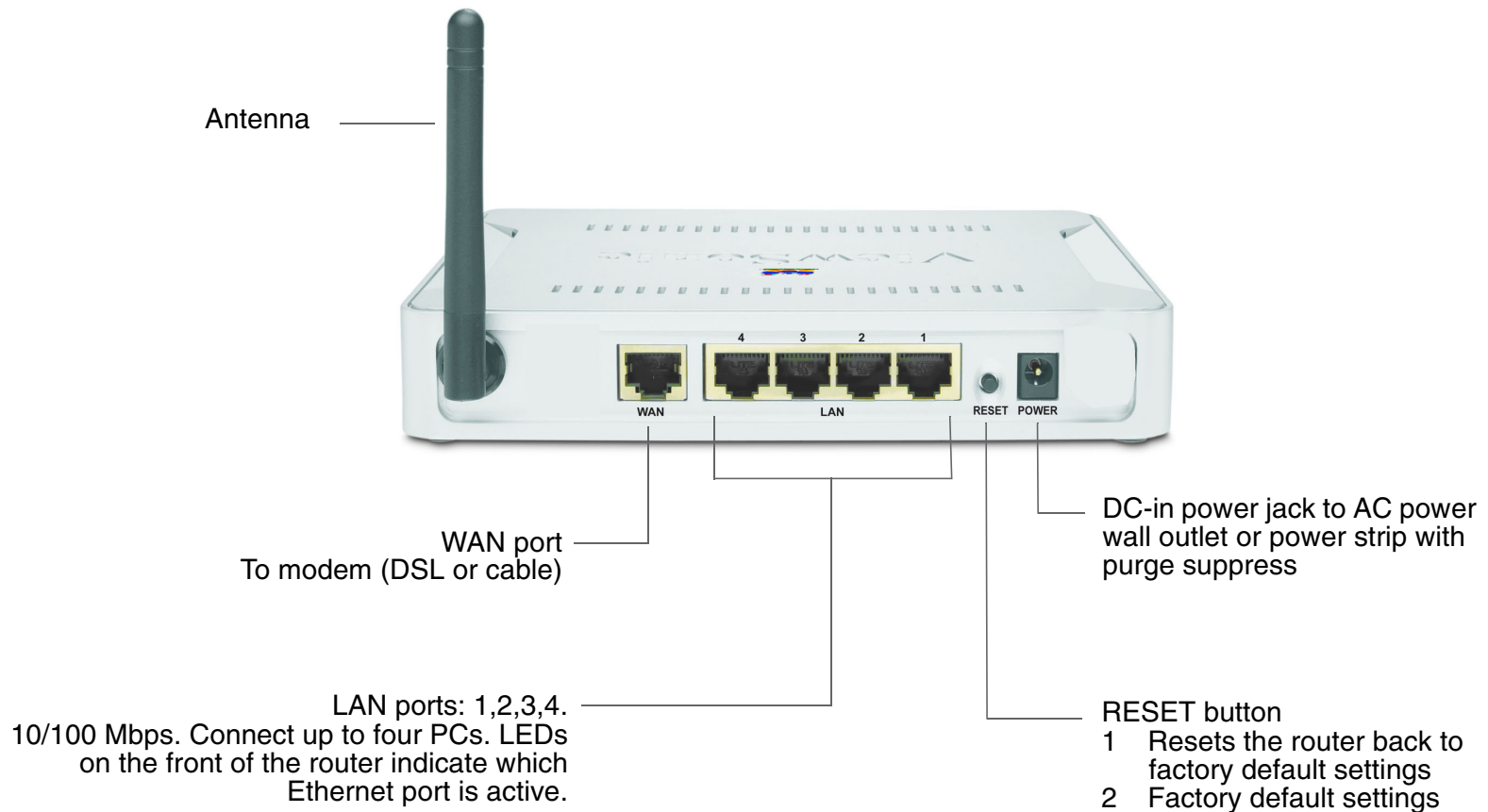

# Chapter 3: Setting up the wireless router

---

This chapter shows how to set up the ViewSonic wireless router to work with multiple devices in three steps: (1) Connect the wireless router. (2) Configure your PC. (3) Configure the wireless router. A typical setup may look like the following:



## Step 1 Connect the wireless router.

- 1 Make sure you have all the setup information from your Internet Service Provider (ISP).
- 2 Make sure that all network hardware is turned off, including the router, computer(s), and cable or DSL model.
- 3 Connect one end of an Ethernet cable to one of the LAN ports as shown on the right (labeled 1, 2, 3, or 4 on the back of the router). Plug the other end of the cable to the Ethernet port on your computer. To connect an additional computer or network devices to the router, repeat this step.

**Optional:** Connect another Ethernet cable from your cable or DSL model to the WAN port on the back of the router.

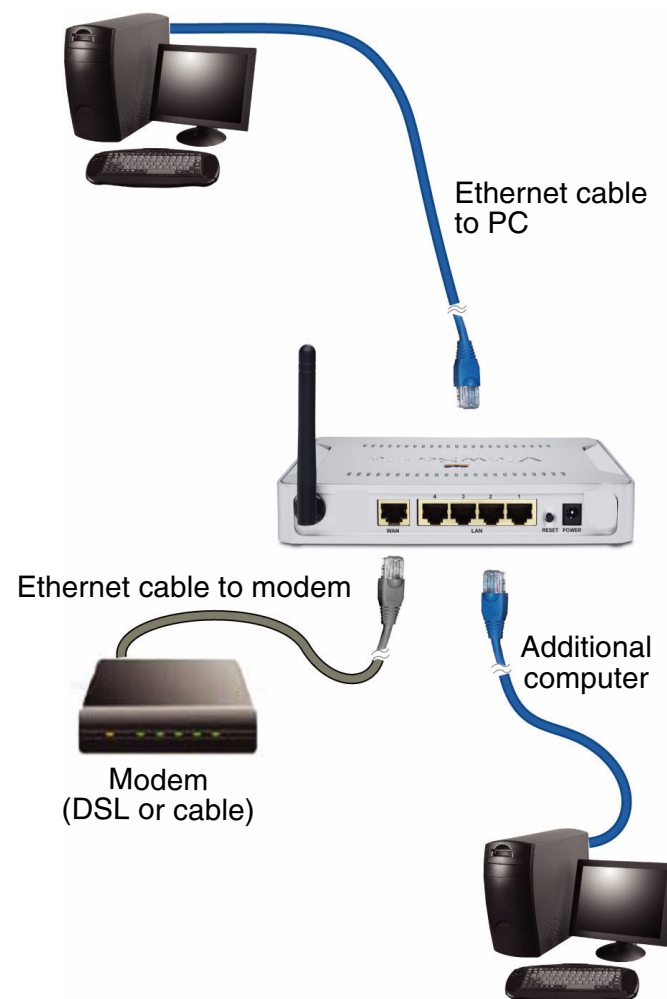

- 4 Connect the AC Power Adapter from the Power Jack on the back of the router to an AC Wall Outlet as shown or to a power strip with surge protection. The Power LED on the front of the router turns blue when there is power.

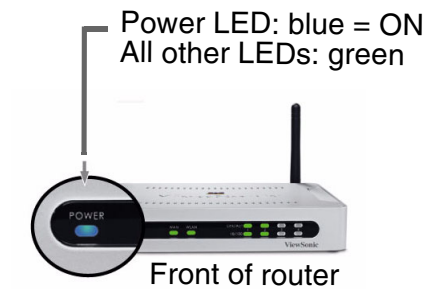
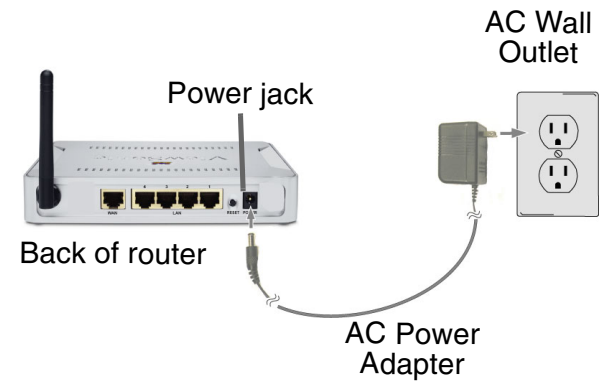

## Step 2 Configure your PC

Make sure that your computer is set to **DHCP** (Dynamic Host Configuration Protocol) to obtain an IP address automatically as follows:

### For Windows 2000 or XP

- 1 Click the **Windows® Start** button > **Control Panel** > **Network and Internet Connections** > **Local Area Connection**. The **Local Area Connection Status** screen appears as shown on the right.
- 2 From the **General** tab (usually appears selected by default), click **Properties**. The **Local Area Connection Properties** screen appears in the next step.

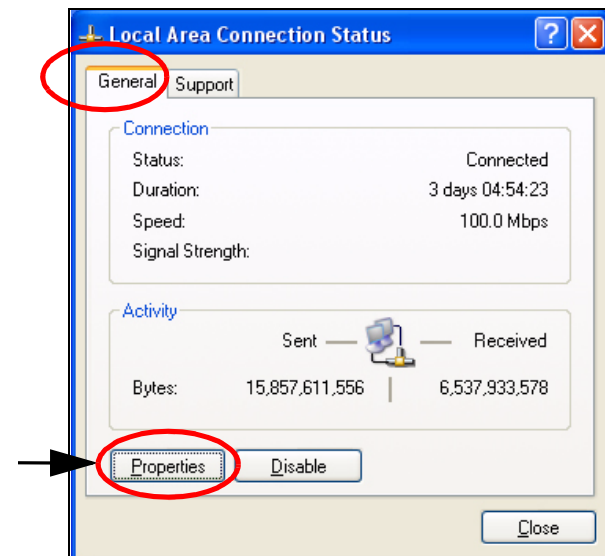

- 3 Check the box next to **Internet Protocol (TCP/IP)** if it isn't already checked by default. Highlight **Internet Protocol (TCP/IP)** if it isn't already highlighted automatically. Click **Properties**. The **Internet Protocol (TCP/IP) Properties** screen appears as shown in the next step.

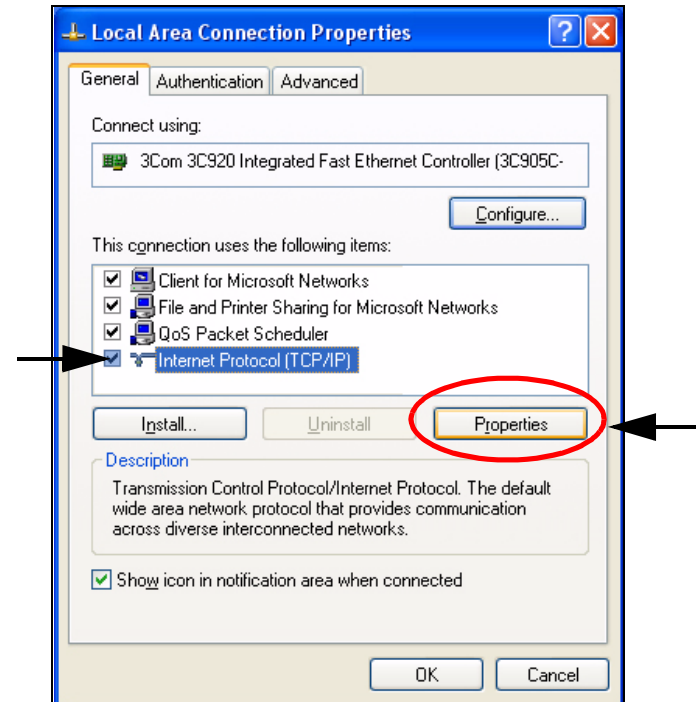

- 4 Select **Obtain an IP address automatically**. Click **OK > OK > Close** to complete the PC configuration.
- 5 Restart your PC if prompted.

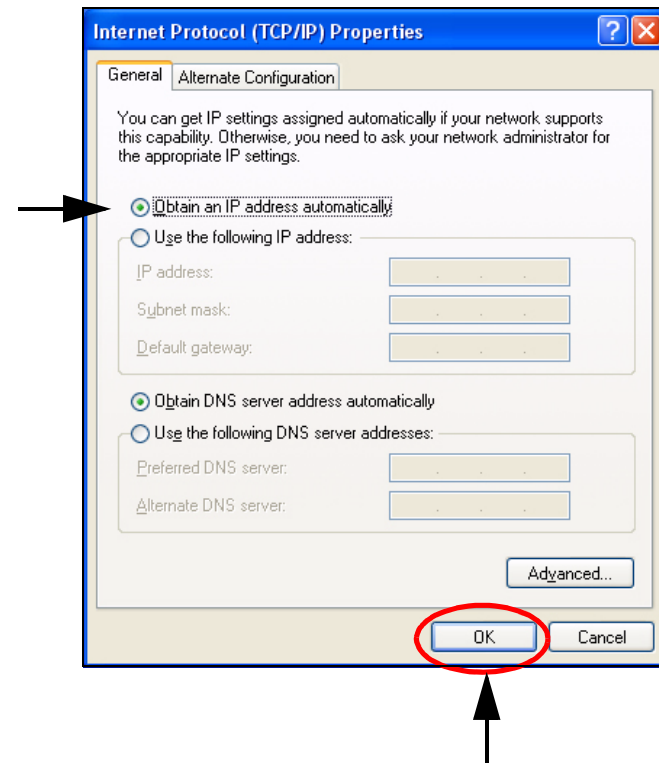



## For Windows® 98 or Me

- 1 Click the **Windows® Start** button > Select **Settings** > Click **Control Panel** > double-click on **Network**. The **Network** screen appears as shown on the right.
- 2 Select the **Configuration** tab if it isn't already selected by default. In the list of installed network components, click the **TCP/IP** line for the applicable Ethernet adapter. Click **Properties**. The **TCP/IP Properties** screen appears as shown in the next step.

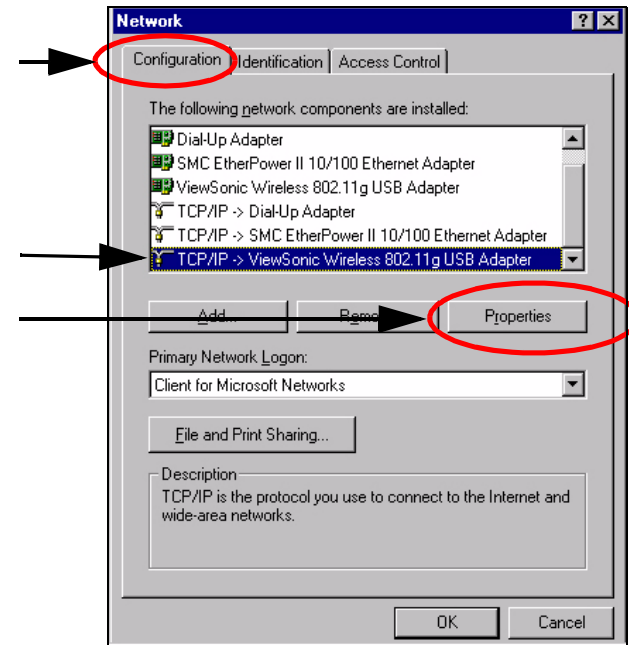

- 3** From the **TCP/IP Properties** screen, select the **IP Address** tab (1). Select **Obtain an IP address automatically** (2). Select the **Gateway** tab (3). The **TCP/IP Properties** screen with the **Gateway** tab appears as shown on the next page.

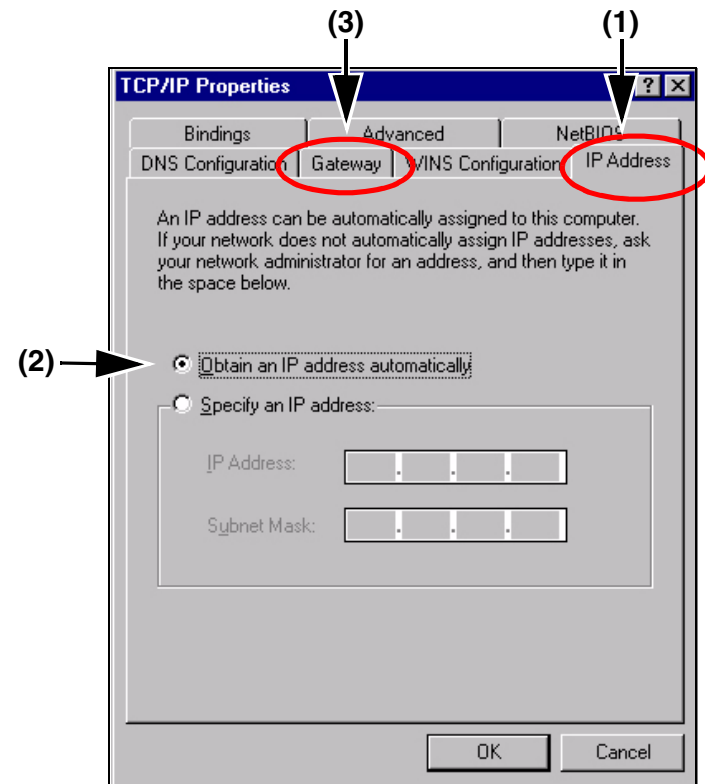

- 4 Verify that the *Installed gateways* field is blank. Click **OK** > **OK**.
- 5 Windows may ask you for the original Windows installation disk or additional files. Look for those files on **C:\windows\options\cabs** or insert your Windows CD-ROM into your CD-ROM drive and check the correct file location: for example if your CD-ROM is D, go to D:\win98, or D:\win9x.
- 6 Restart your PC if prompted.

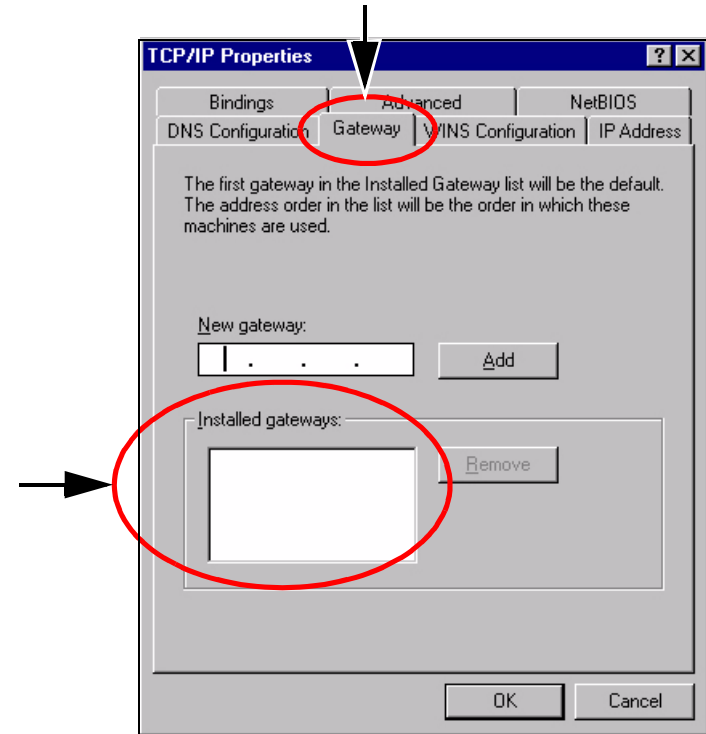

## Step 3 Configure the wireless router

You only need to configure the router once on any computer that is already set up using Web-based utility screens on the next few pages. Default settings in the table on the right may be helpful during the configuration process.

- 1 Open your web browser. In the address field, enter **http://192.168.1.1** and press **Enter**. A logon window appears like the one shown on the next page.

<b>Basic Settings</b>	<b>Default</b>
Internet Configuration Type	Automatic Configuration-DHCP
Wireless Router IP Address	192.168.1.1
Wireless Router Subnet Mask	255.255.255.0
Router Password	admin (lowercase)
<b>DHCP Settings</b>	
DHCP Server	Enable
DHCP Starting IP Address	192.168.1.100
Number of DHCP Client Users	50
<b>2.4GHz Wireless Setting</b>	
SSID	viewsonic
Channel	6
WEP (Encryption)	Disable

## 2 The Logon screen:

**User name:** leave blank.

**Password:** enter the default password **admin** in all lowercase letters. (Later on, we recommend changing the default to your own password for added security using the Password tab of the following web-based utility.)

Click **OK**. The **Primary Setup** screen appears as shown in the next step.

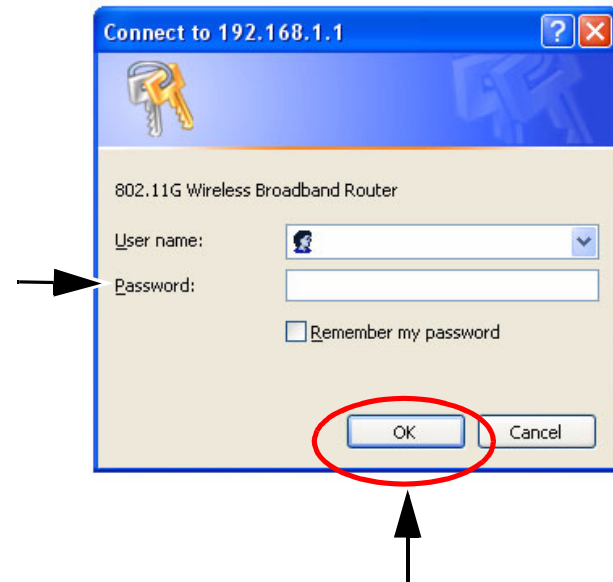

### 3 The Primary Setup screen:

**Host Name:** if requested by your ISP (usually cable ISPs). Otherwise, leave this field blank.

**Domain Name:** if required by your ISP. Otherwise, leave this field blank.

**Connection Type:** Click the **down arrow** for a drop-down menu with several Connection Types. **IMPORTANT!** The **Primary Setup** screen displays different features depending on which Connection Type you select. Select one of the following:

- **Dynamic IP Setting** - DHCP (Automatic Configuration). If you are connecting through DHCP or a dynamic IP address from your ISP, keep this default setting.
- **Static IP Address.** If your ISP assigns you a Static IP Address, select Static IP Address. More fields appear below Connection Type. Enter the Internet IP Address, Subnet Mask, Default Gateway, and enter at least one DNS address.
- **PPPoE** (for DSL). If you are connecting through PPPoE, select PPPoE from the drop-down menu. Complete the User Name and Password fields.

Continued.....

The screenshot shows the 'Primary Setup' screen of a ViewSonic wireless router. The 'Primary Setup' tab is selected and circled in red. A black arrow points to this tab. Below the navigation bar, the 'Primary Setup' section contains a 'Time Zone' dropdown menu set to '(GMT-08:00) Pacific Time (USA & Canada)' and a checked checkbox for 'Automatically adjust clock for daylight saving changes.' The 'Internet' section has a 'MAC Address' of '00:0C:10:21:32:03', 'Host Name' and 'Domain Name' fields, and a 'Connection Type' dropdown menu set to 'Dynamic IP Setting', which is circled in red. Three black arrows point to the 'Host Name', 'Domain Name', and 'Connection Type' fields. The 'LAN' section has a 'MAC Address' of '00:0C:10:21:32:05', 'IP Address' (192.168.1.1), and 'Subnet Mask' (255.255.255.0) fields. The 'Wireless' section has a 'MAC Address' of '00:0C:10:21:32:04', 'Mode' dropdown set to '11b+g' (circled in red), 'Domain' set to 'FCC', 'Channel' dropdown set to '6' (circled in red), 'SSID' set to 'viewsonic', and 'Security' radio buttons with 'Enable' selected (circled in red). A 'Configure Security' button is also circled in red. A black arrow points from this button to the text below. At the bottom are 'Apply' and 'Cancel' buttons.

Goes to the screen to select one of the following **Security modes**:

- WEP
- WPA Pre-Shared
- WPA Radius

**Wireless: Mode:** click the down arrow for the drop-down menu with a list of wireless networking modes. Select one of the following modes based on your environment setting:

- **Disable:** To disable wireless networking for 802.11g and 802.11b, select Disable.
- **11b+g:** If you have 802.11b and 802.11g devices in your network, then keep the default setting, 11b+g.
- **11g Only:** If you have only 802.11g devices, select 11g Only.
- **G Plus\*:** This mode requires the same technology from the client devices.
  - \* **Important!** When operating at highest speeds, this Wi-Fi device achieves an actual throughput of up to 34 Mbps, which is the equivalent throughput of a system following 802.11g protocol and operating at a signaling rate of 125 Mbps.

**Channel:** customize as needed. It is recommended that you change the channel to prevent interference with other wireless routers in the vicinity.

**SSID:** customize as needed. This field automatically defaults to **ViewSonic** when **11b+g** is selected in the previous **Mode** field. For added security, change **viewsonic** in the SSID to a unique name.

**Security:** to enable Security, (recommended), select **Enable**.

**Configure Security:** click **Configure Security**. The Configure Security screen appears as shown in the next step.

## 4 Configure the **Security Mode**

### **Security Mode: WEP**

**Security Mode:** to customize the **Security** settings, click the down arrow for the pull-down menu. Select **WEP**.

**WEP Encryption: Wired Equivalent Protection.** This field automatically defaults to **64bits/10 hex** digital when **WEP** is selected in the **Security Mode** field. To select a different **WEP Encryption** such as **Passphrase** or **Hex**, go to the **Security Mode** field and click the down arrow for a pull-down menu with other options.

**Passphrase:** type your personalized passphrase – alpha-numeric, not case sensitive. Click **Generate**. Hex keys automatically appear in the fields for Key 1, 2, 3, and 4. Important! To configure your wireless client devices in the future or to change your **Passphrase**, write your **Passphrase** on a separate piece of paper along with any one of the four generated Key codes in the fields for Key 1, 2, 3, and 4.

To save your settings, click **Apply** at the bottom of the **Security** screen. The full **Primary Setup** screen reappears.

Click **Apply** on the **Primary Setup** screen. You are now ready to configure your wireless client devices if needed. For other advanced configuration of the router, see the **WR100 User Guide** on the *Networking Companion CD*. Close the web browser.

The screenshot shows the 'Security' configuration page. At the top, it states: 'The Access Point supports 3 different types of security settings. There are: WPA Pre-Shared Key, WPA RADIUS, and WEP.' The 'Security Mode' dropdown is set to 'WEP'. Below it, 'Default Transmit Key' has radio buttons for 1, 2, 3, and 4, with '1' selected. 'WEP Encryption' is set to '64 bits/10 hex digits'. There is a 'Passphrase' field and a 'Generate' button. Below these are four 'Key' fields (Key 1, Key 2, Key 3, Key 4). At the bottom, there are 'Apply' and 'Cancel' buttons. Red circles highlight the 'Security Mode' dropdown, the 'Generate' button, and the 'Apply' button. Arrows point to the 'Security Mode' dropdown, the 'WEP Encryption' dropdown, the 'Passphrase' field, and the 'Apply' button.



Restart your computer(s) to get the router's new settings if prompted.

Test the setup by opening your web browser from any computer and entering **<http://www.viewsonic.com>**

For more detailed information, see the **WR100 User Guide Troubleshooting** section on the *Networking Companion CD*. Then, if you still need help, contact ViewSonic Customer Support. See the **Customer Support** table in the **Appendix** of this user guide for contact information.

## Security Mode: WPA Pre-shared Key

**Important Notice:** In order to use the WPA correctly, make sure that your current wireless router's driver, and Wireless Utility can support the WPA. The WPA needs 802.1x authentication (when RADIUS mode is chosen), though the Operating System must also support 802.1x protocol. For Microsoft's OS family, only Windows XP has incorporated this by default. Other operating systems must install a third-party client software.

- 1 Security Mode:** click the down arrow for a pull-down menu. click on **WPA-Preshared Key**.
- 2 WPA Algorithms:** click one of the following options:
  - **TKIP** (Temporal Key Integrity Protocol). TKIP uses a stronger encryption method and incorporates MIC (Message Integrity Code) to provide protection against hackers.
  - **AES** (Advanced Encryption System) uses a symmetric 128-Bit block data encryption.
- 3 WPA Shared Key:** enter the Pre-Shared Key – between 8 to 63 alpha-numeric characters.
- 4 Group Key Renewal:** enter the time period of renewal. The default selection is 300 seconds.

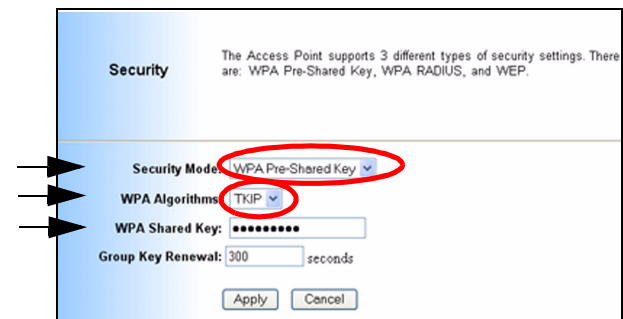

## Security Mode: WPA Radius

- 1 Security Mode: WPA RADIUS:** uses an external RADIUS server to perform user authentication. To use WPA RADIUS, enter the IP address of the RADIUS server, the RADIUS Port (default is 1812) and the shared secret from the RADIUS server.
- 2 WPA Algorithms:** Choose your algorithm method: TKIP or AES.
- 3 Radius Server Address:** Input your RADIUS Server IP address.
- 4 Radius Server Port:** Input the Authentication port of your RADIUS server; the default port being used is 1812
- 5 Radius Shared Secret:** The RADIUS server accepts the authentication if both Shared Keys match.
- 6 Group Key Renewal:** Input the period of renewal time; the default selection is 300 seconds
- 7** Click **Apply** to save your settings.

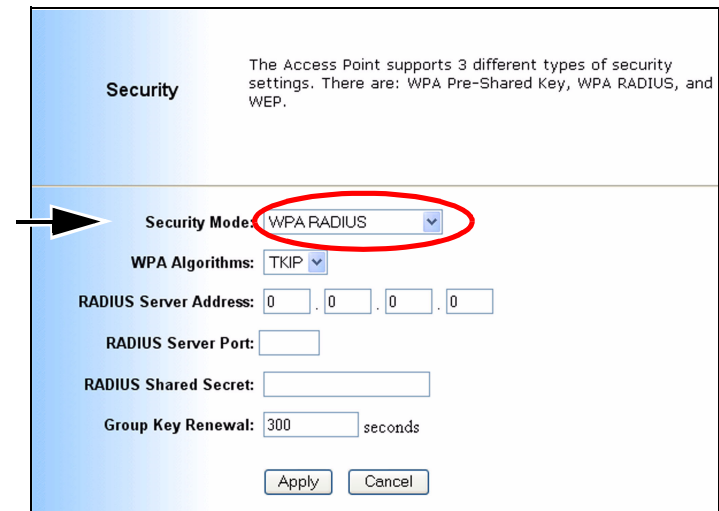

**Security** The Access Point supports 3 different types of security settings. There are: WPA Pre-Shared Key, WPA RADIUS, and WEP.

Security Mode: WPA RADIUS

WPA Algorithms: TKIP

RADIUS Server Address: 0 . 0 . 0 . 0

RADIUS Server Port:

RADIUS Shared Secret:

Group Key Renewal: 300 seconds

Apply Cancel

# Chapter 4 Advanced Web Management Settings

## Security (Firewall)

**Wireless router Password:** Change the password for the Wireless router by typing the password in the **Enter New Password** field. Then, type it again into the **Re-enter** field to confirm. Click the **Apply** button to save the setting.

Use the default password (“admin”) when you first open the configuration pages. After you have configured these settings, set a new password for the Wireless router (using the Security screen). This increases security by protecting the Wireless router from unauthorized changes.

**VPN Pass-Through:** Virtual Private Networking (VPN) is typically used for work-related networking. For VPN tunnels, the Wireless router supports IPsec Pass-Through, L2TP Pass-Through, and PPTP Pass-Through.

- **IPSec** - Internet Protocol Security (IPSec) is a suite of protocols used to implement secure exchange of packets at the IP layer. To allow IPSec tunnels to pass through the Wireless router, IPSec Pass-Through is enabled by default. To disable IPSec Pass-Through, uncheck the box next to IPSec.
- **L2TP** - Layer 2 Tunneling Protocol is a protocol used to tunnel Point-to-Point Protocol (PPP) over the Internet. To allow L2TP

The screenshot shows the ViewSonic router's web management interface. The 'Security' tab is selected and circled in red. The 'Router Password' section has two input fields for 'Enter New Password' and 'Re-enter to Confirm', with arrows pointing to them. The 'VPN Pass-Through' section has checkboxes for IPsec, L2TP, and PPTP, all of which are checked. The 'Web Filters' section has checkboxes for Proxy, Java, ActiveX, and Cookies, all of which are unchecked. The 'DMZ' section has a dropdown menu set to 'Disable' and a text box for 'DMZ Host IP Address' containing '192.168.1.0'. The 'Block WAN Request' section has a dropdown menu set to 'Enable'. The 'Apply' button is circled in red.

tunnels to pass through the Wireless router, L2TP Pass-Through is enabled by default. To disable L2TP Pass-Through, uncheck the box next to L2TP.

- **PPTP** - Point-to-Point Tunneling Protocol is the method used to enable VPN sessions to a Windows NT 4.0 or 2000 server. To allow PPTP tunnels to pass through the Wireless router, PPTP Pass-Through is enabled by default. To disable PPTP Pass-Through, uncheck the box next to PPTP.

**Web Filters:** Using the Web Filters feature, you may enable up to four different filters.

- **Proxy** - Use of WAN proxy servers may compromise network security. Denying Proxy will disable access to any WAN proxy servers. To enable proxy filtering, click the box next to Proxy.
- **Java** - Java is a programming language for websites. If you deny Java, you run the risk of not having access to Internet sites created using this programming language. To enable Java filtering, click the box next to Java.
- **ActiveX** - ActiveX is a programming language for websites. If you deny ActiveX, you run the risk of not having access to Internet sites created using this programming language. To enable ActiveX filtering, click the box next to ActiveX.
- **Cookies** - A cookie is data stored on your PC and used by Internet sites when you interact with them. To enable cookie filtering, click the box next to Cookies.

**DMZ:** The DMZ hosting feature allows one local user to be exposed to the Internet for use of a special-purpose service such as Internet gaming or videoconferencing. DMZ hosting forwards all

the ports at the same time to one PC. The Port Forwarding feature is more secure because it only opens the ports you want to have opened, while DMZ hosting opens all the ports of one computer, exposing the computer so the Internet can see it.

Any PC whose port is being forwarded must have its DHCP client function disabled and should have a new static IP address assigned to it because its IP address may change when using the DHCP function.

- 1** To expose one PC, select **Enable**.
- 2** Enter the computer's **IP address** in the **DMZ Host IP Address** field.
- 3** Click the **Apply** button.

**Block WAN ICMP Request:** By enabling the Block WAN Request feature, you can prevent your network from being "pinged," or detected, by other Internet users. The Block WAN Request feature also reinforces your network security by hiding your network ports. Both functions of the Block WAN Request feature make it more difficult for outside users to work their way into your network. This feature is enabled by default. Select **Disable** to disable this feature.

Check all the settings and click **Apply** to save them.

# System

Restore Factory Default: Click the **Yes** button to reset all configuration settings to factory default values.

**IMPORTANT:** Any settings you have saved will be lost when the default settings are restored. Click the **No** button to disable the Restore Factory Defaults feature.

Click the **Apply** button to save the setting.

Firmware Upgrade: Click the **Upgrade** button to load new firmware onto the Wireless router. If the wireless router is not experiencing difficulties, then there is no need to download a more recent firmware version, unless that version has a new feature that you want to use.

**Note:** When you upgrade the wireless router's firmware, you may lose its configuration settings, so make sure you write down the wireless router's settings before you upgrade its firmware.

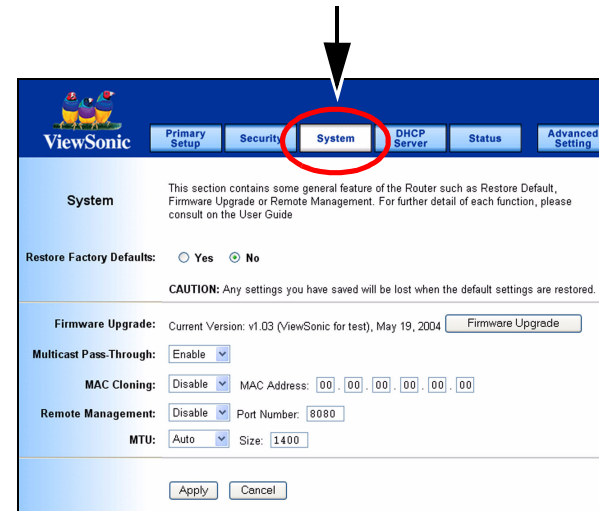

## To upgrade the Wireless router's firmware:

- 1 Download the firmware upgrade file from the internet.
- 2 Extract the firmware upgrade file.
- 3 Click the **Upgrade** button.
- 4 On the Firmware Upgrade screen, click the **Browse** button to locate the firmware upgrade file.
- 5 Double-click the firmware upgrade file.
- 6 Click the **Upgrade** button, and follow the on-screen instructions.

**IMPORTANT!** Do not power off the wireless router or press the **Reset** button while the firmware is being upgraded.





## MAC Cloning

The Wireless router's MAC address is a 12-digit code assigned to a unique piece of hardware for identification. Some ISPs require that you register the MAC address of your network card/adaptor, which was connected to your cable or DSL modem during installation. If your ISP requires MAC address registration, find your wireless router's MAC address by following the instructions for your PC's operating system.

### For Windows 98 and Millennium

- 1 Click the **Start** button on your PC and select **Run**.
- 2 Type "**winipcfg**" in the field provided and press the **OK** key.
- 3 Select the **Ethernet Adapter** you are using.
- 4 Click **More Info**.
- 5 Write down your **Ethernet MAC address**.

### **MAC (Medium Access Controller)**

*A specific MAC address is hard-coded into every wireless 802.11 for security. Only the 802.11 radios that have their specific MAC address added to that network's MAC table can get into the network.*

## For Windows 2000 and XP:

- 1 Click the **Start** button and select **Run**.
- 2 Type **cmd** in the field provided, and press the **OK** key.
- 3 At the command prompt, run **ipconfig /all**, and look at your wireless router's physical address.
- 4 Write down your wireless router's **MAC address**.

To clone your network wireless router's MAC address onto the wireless router and avoid calling your ISP to change the registered MAC address, follow these instructions.

- 1 Select **Enable**.
- 2 Enter your wireless router's **MAC address** in the **MAC Address** field.
- 3 Click the **Apply** button.

To disable **MAC address** cloning, keep the default setting, **Disable**.

**Remote Management:** This feature allows you to manage your wireless router from a remote location.

**Internet.** To disable this feature, keep the default setting, **Disable**. To enable this feature, select **Enable**, and use the specified port (default is 8080) on your PC to remotely manage the wireless router. Also, change the wireless router's default password to one

of your own, if you haven't already. A unique password increases security.

To remotely manage the wireless router, enter <http://xxx.xxx.xxx.xxx:8080> (the x's represent the wireless router's Internet IP address, and 8080 represents the specified port) in your web browser's address field. You will be asked for the wireless router's password. After successfully entering the password, you will be able to access the wireless router's web-based utility.

**IMPORTANT: If the Remote Management feature is enabled, anyone who knows the wireless router's Internet IP address and password will be able to alter the wireless router's settings.**

**MTU:** MTU is the Maximum Transmission Unit. It specifies the largest packet size permitted for Internet transmission. Keep the default setting, Auto, to have the wireless router select the best MTU for your Internet connection. To specify a MTU size, select Manual, and enter the value desired (default is 1400). You should leave this value in the 1200 to 1500 range.

**Traffic Log:** The wireless router can keep logs of all incoming or outgoing traffic for your Internet connection. This feature is disabled by default. To keep activity logs, select Enable.

To keep a permanent record of activity logs as a file on your PC's hard drive, Log viewer software must be used. In the **Send Log to** field, enter the fixed IP address of the PC running the Log viewer software. The wireless router will send updated logs to that PC.

To see a temporary log of the wireless router's most recent incoming traffic, click the **Incoming Access Log** button. To see a temporary log of the wireless router's most recent outgoing traffic, click the **Outgoing Access Log** button. Click the **Apply** button to save the setting.

## DHCP Server

The DHCP Server screen allows you to configure the settings for the wireless router's Dynamic Host Configuration Protocol (DHCP) server function. The wireless router can be used as a DHCP server for your network. A DHCP server automatically assigns an IP address to each computer on your network. If you choose to enable the wireless router's DHCP server option, you must configure your entire network PCs to connect to a DHCP server, the wireless router.

If you disable the wireless router's DHCP server function, you must configure the IP Address, Subnet Mask, and DNS for each network computer (note that each IP Address must be unique).

**DHCP Server:** Select the **Enable** option to enable the wireless router's DHCP server option.

If you already have a DHCP server on your network or you do not want a DHCP server, then select **Disable** from the options.

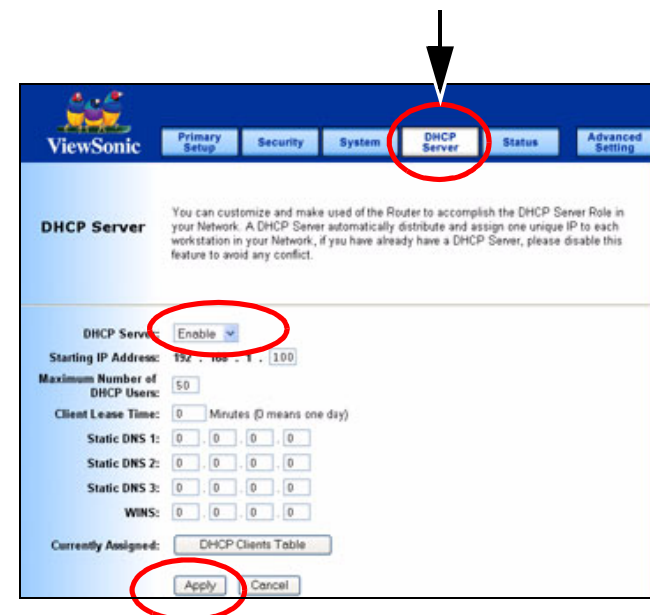

**Starting IP Address:** Enter a numerical value for the DHCP server to start with when issuing IP addresses. Because the wireless router's default IP address is 192.168.1.1, the Starting IP Address must be 192.168.1.2 or greater, but smaller than 192.168.5.253. The default Starting IP Address is 192.168.1.100.

**Maximum Number of DHCP Users:** Enter the maximum number of PCs that you want the DHCP server to assign IP addresses to. The absolute maximum is 253 - possible if 192.168.1.1 is your starting IP address. The default is 50.

**Client Lease Time:** The Client Lease Time is the amount of time a network user will be allowed connection to the wireless router with their current dynamic IP address.

Enter the amount of time, in minutes, that the user will be "leased" this dynamic IP address. The default is 0 minutes, which means one day.

**Static DNS 1-3:** The Domain Name System (DNS) is how the Internet translates domain or website names into Internet addresses or URLs. Your ISP will provide you with at least one DNS Server IP Address. If you wish to utilize another, enter that IP Address in one of these fields. You can enter up to three DNS Server IP Addresses here. The wireless router will utilize these for quicker access to functioning DNS servers.

**WINS:** The Windows Internet Naming Service (WINS) manages each PC's interaction with the Internet. If you use a WINS server, enter that server's IP Address here. Otherwise, leave this blank.

Currently Assigned: Click the DHCP Clients Table button to see a list of PCs assigned IP addresses by the wireless router. For each PC, the list shows the client hostname, MAC address, IP address, and the amount of DHCP client lease time left. Click the **Refresh** button to display the most current information.

Click **Apply** to save your settings.

## Status

This screen displays the wireless router's current status and settings. This information is read-only.

This page will auto re-flash every five seconds to update the information.

**Host Name:** The **Host Name** is the name of the wireless router. This entry is necessary for some ISPs.

**Domain Name:** The **Domain Name** is the name of the wireless router's domain. This entry is necessary for some ISPs.

**WAN IP Release:** Click the **WAN IP Release** button to delete the wireless router's current Internet IP address.

**WAN IP Renew:** Click the **WAN IP Renew** button to get a new Internet IP address for the wireless router.

Click the **Refresh** button to refresh the wireless router's status and settings.



# Advanced Wireless

**Wireless MAC Filters:** This function allows the administrator to have access control by entering the MAC address of client stations.

- 1 When you select **Enable**, two new options appear under Wireless MAC Filters: **Prevent** or **Permit**.
- 2 Select **Prevent** or **Permit**.
- 3 Click on **Edit MAC Filter List** to add the client stations. The MAC list shown on the next page.

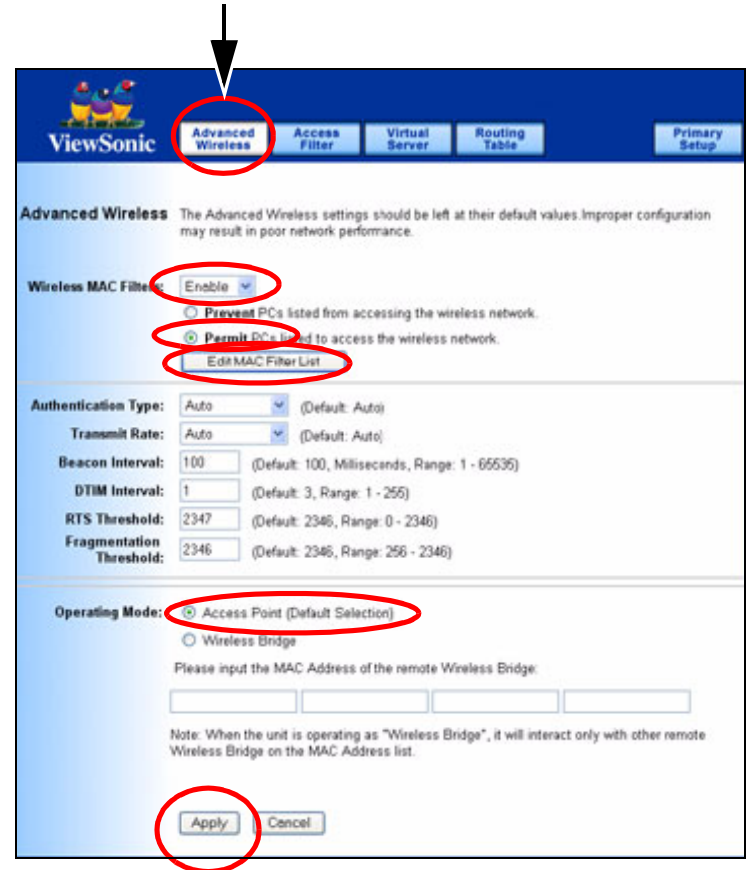

The list could store up to 40 different MAC addresses. When entering an address, use the format shown under the title of the screen.

**MAC Address Filter List**  
Enter MAC Address in (xx:xx:xx:xx:xx:xx) format

MACAddresses 1~20 ▾

MAC 01 :	<input type="text" value="00:00:00:00:00:00"/>	MAC 11 :	<input type="text" value="00:00:00:00:00:00"/>
MAC 02 :	<input type="text" value="00:00:00:00:00:00"/>	MAC 12 :	<input type="text" value="00:00:00:00:00:00"/>
MAC 03 :	<input type="text" value="00:00:00:00:00:00"/>	MAC 13 :	<input type="text" value="00:00:00:00:00:00"/>
MAC 04 :	<input type="text" value="00:00:00:00:00:00"/>	MAC 14 :	<input type="text" value="00:00:00:00:00:00"/>
MAC 05 :	<input type="text" value="00:00:00:00:00:00"/>	MAC 15 :	<input type="text" value="00:00:00:00:00:00"/>
MAC 06 :	<input type="text" value="00:00:00:00:00:00"/>	MAC 16 :	<input type="text" value="00:00:00:00:00:00"/>
MAC 07 :	<input type="text" value="00:00:00:00:00:00"/>	MAC 17 :	<input type="text" value="00:00:00:00:00:00"/>
MAC 08 :	<input type="text" value="00:00:00:00:00:00"/>	MAC 18 :	<input type="text" value="00:00:00:00:00:00"/>
MAC 09 :	<input type="text" value="00:00:00:00:00:00"/>	MAC 19 :	<input type="text" value="00:00:00:00:00:00"/>
MAC 10 :	<input type="text" value="00:00:00:00:00:00"/>	MAC 20 :	<input type="text" value="00:00:00:00:00:00"/>



## **Authentication Type:**

**Auto:** Auto is the default authentication algorithm. It will change its authentication type automatically to fulfill client's requirement.

**Open System:** Open System authentication is not required to be successful while a client may decline to authenticate with any particular other client.

**Shared Key:** Shared Key is only available if the WEP option is implemented. Shared Key authentication supports authentication of clients as either a member of those who know a shared secret key or a member of those who do not. IEEE 802.11 Shared Key authentication accomplishes this without the need to transmit the secret key in clear. Requiring the use of the WEP privacy mechanism.

**Transmission Rate:** The rate of data transmission should be set depending on the speed of your wireless network. You can select from a range of transmission speeds, or you can select AUTO to have the wireless router automatically use the fastest possible data rate and enable the Auto-Fallback feature. Auto-Fallback will negotiate the best possible connection speed between the wireless router and a wireless client. The default setting is AUTO.

**DTIM Interval:** This value indicates the interval of the Delivery Traffic Indication Message (DTIM). A DTIM field is a countdown field informing clients of the next window for listening to broadcast and multicast messages. When the Access Point has buffered broadcast or multicast messages for associated clients, it sends

the next DTIM with a DTIM Interval value. Access Point Clients hear the beacons and awaken to receive the broadcast and multicast messages.

**Beacon Interval:** The Beacon Interval value indicates the frequency interval of the beacon. Enter a value between 20 and 1000. A beacon is a packet broadcast by the wireless router to synchronize the wireless network. The default value is 100.

**RTS Threshold:** This value should remain at its default setting of 2346. Should you encounter inconsistent data flow, only minor modifications are recommended. If a network packet is smaller than the preset RTS threshold size, the RTS/CTS mechanism will not be enabled. The wireless router sends Request to Send (RTS) frames to a particular receiving station and negotiates the sending of a data frame. After receiving an RTS, the wireless station responds with a Clear to Send (CTS) frame to acknowledge the right to begin transmission.

**Fragmentation Threshold:** This value specifies the maximum size for a packet before data is fragmented into multiple packets. It should remain at its default setting of 2346. If you experience a high packet error rate, you may slightly increase the Fragmentation Threshold. Setting the Fragmentation Threshold too low may result in poor network performance. Only minor modifications of this value are recommended.

**AP Mode or Wireless Bridge Mode:** wireless router can operate in two modes. When the AP Mode is selected, the device operates as a normal Access Point. Providing every wireless client station a

join network point. The Wireless Bridge Mode will be able to join different wireless router wirelessly by input the destination MAC Address.

Click **Apply** to save your settings.

## Access Filters

The Access Filter screen allows you to block or allow specific kinds of Internet usage. You can set up Internet access policies for specific PCs and set up filters by using network port numbers.



## Add service to list

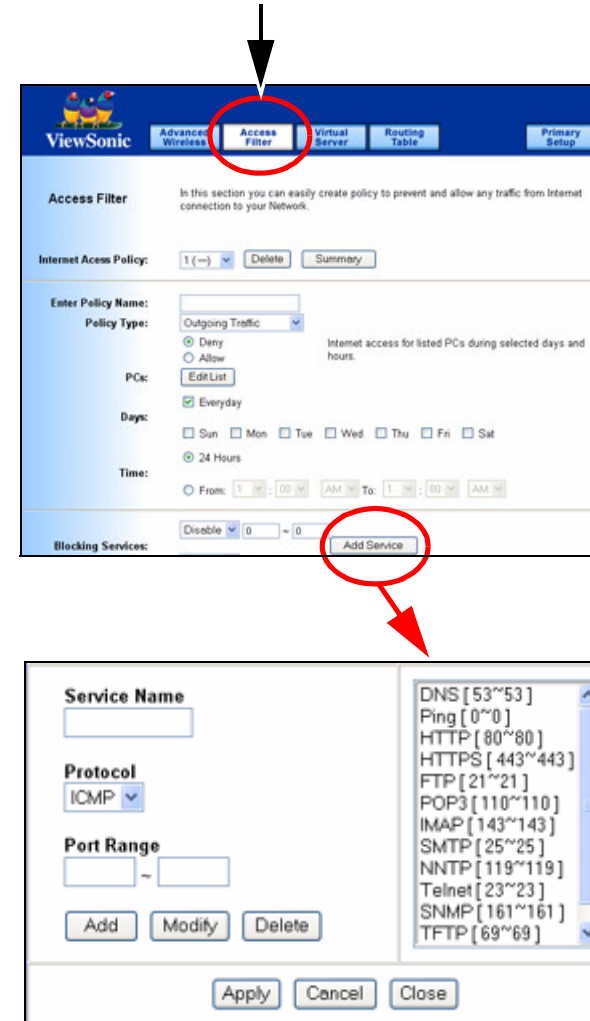

## INTERNET ACCESS POLICY

This feature allows you to customize up to ten (10) different Internet Access Policies for particular PCs, which are identified by their IP or MAC addresses. For each policy's designated PCs, the wireless router can do one or more of the following:

- Block or allow Internet access or inbound traffic during the days and time periods specified
- Block designated services
- Block websites with specific URL addresses
- Block websites that use specific keywords in their URL addresses.

### To create or edit a policy, do the following:

- 1 Select the policy's number (1-10) in the drop-down menu.
- 2 Enter a name in the **Enter Policy Name** field.
- 3 Select Internet Access or **Inbound Traffic** from the Policy Type drop-down box, depending on the kind of access you want to control. Select **Internet Access** to control your network PCs' access to the Internet. Select **Inbound Traffic** to control Internet PCs' access to your local area network.

**IMPORTANT!** The screen's settings will vary depending on which Policy Type you select.

- 4 Select **Deny** or **Allow**, depending on how you want to control access for specific PCs.
- 5 Click the **Edit List** button next to PCs or Internet PCs.
  - (1). On the List of PCs or List of Internet PCs screen, specify **PCs by IP address** or **MAC address**. Enter the appropriate **IP addresses** into the IP fields. If you have a range of IP addresses to filter, complete the appropriate IP Range fields. Enter the appropriate MAC addresses into the MAC fields.
  - (2). Click the **Apply** button to save your changes. Click the **Cancel** button to cancel your unsaved changes. Click the **Close** button to return to the Internet Filter screen.
- 6 Set the days when access will be filtered. Keep the default setting, **Everyday**, or select the appropriate days of the week.
- 7 Set the time when access will be filtered. Keep the default setting, **24 Hours**, or check the box next to **From** and use the drop-down boxes to designate a specific time period.

**IMPORTANT!** Access for the listed PCs is controlled during the selected days and times. Any blocked services or websites are blocked at all times.

- 8 In the **Blocking Services** drop-down boxes, select the services you want to block (the default setting is None). In the **Blocking Services** fields, the range of ports for this service will appear. If

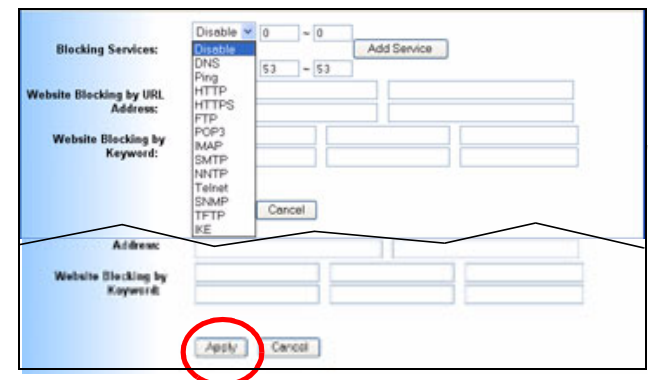

you want to change the range of **ports**, enter the **new** numbers in the **Blocking Services** fields, or edit the service's settings.

To add a service or edit a service's settings

- (1). Click the **Add Service** button.
  - (2). To create a new service, enter the name of the service in the **Service Name** field. To edit a service's settings, select the service from the box on the right of the screen.
  - (3). From the **Protocol** drop-down menu, select the protocol type for this service: **ICMP**, **UDP**, **TCP**, or **UDP & TCP**.
  - (4). In the **Port Range** fields, enter the range of ports for this service.
  - (5). To add a service, click the **Add** button. To edit the settings for a service, click the **Modify** button.
  - (6). To delete a service, select the service from the box on the right of the screen. Click the **Delete** button.
  - (7). Click the **Apply** button to save your changes. Click the **Cancel** button to undo your changes. Click the **Close** button to close the **Add Service** window.
- 9** If you want to block websites with specific URL addresses, enter each URL address in a Website Blocking by URL Address field. You can enter up to four URL addresses. (This feature is not available if you chose Inbound Traffic for the Policy Type.)
- 10** If you want to block websites that use specific keywords as part of their URL addresses, enter each keyword in a Website

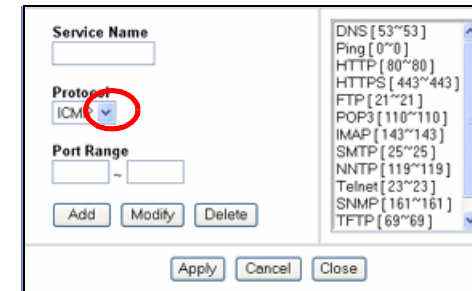

Blocking by Keyword field. You can enter up to six keywords. (This feature is not available if you chose Inbound Traffic for the Policy Type.)

- 11** Click the **Apply** button to save your settings for an Internet Access Policy. Click the **Cancel** button to cancel your unsaved changes.
- 12** To create or edit additional policies, repeat steps 1-11.

## Delete

To delete an Internet Access Policy, select the policy's number, and click the **Delete** button.

## Summary

To see a summary of all the policies, click the **Summary** button. The **Internet Policy Summary** screen will show each policy's number, Name, Type, Days, and Time of Day. To delete a policy, click its box, and then click the **Delete** button. Click the **Close** button to return to the **Internet Filter** screen.



# Virtual Server

The **Virtual Server** screen sets up public services on your network, such as web servers, ftp servers, e-mail servers, or other specialized Internet applications. (Specialized Internet applications are any applications that use Internet access to perform functions such as videoconferencing or online gaming. Some Internet applications may not require any forwarding.)

When users send this type of request to your network via the Internet, the wireless router will forward those requests to the appropriate PC. Any PC whose port is being forwarded must have its **DHCP client** function disabled and must have a new static IP address assigned to it because its IP address may change when using the **DHCP** function.

- 1 Applications.** Enter the name of the public service or other Internet application.
- 2 External Port.** Enter the numbers of the External Ports (the port numbers seen by users on the Internet).
- 3 Protocol TCP.** Click this checkbox if the application requires TCP.
- 4 Protocol UDP.** Click this checkbox if the application requires UDP.

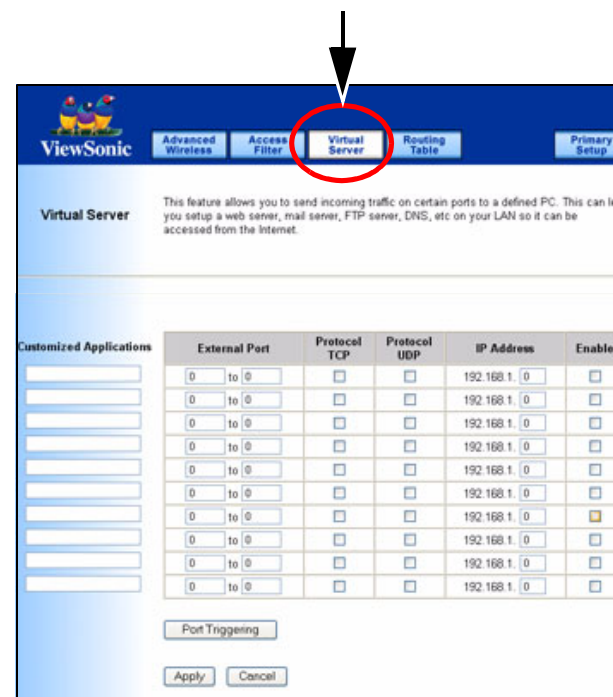

**5 IP Address.** Enter the IP Address of the PC running the application.

**Enable.** Click the **Enable** checkbox to enable port forwarding for the application.

**6 Port Triggering.** Port Triggering is used for special Internet applications whose outgoing ports differ from the incoming ports. For this feature, the wireless router will watch outgoing data for specific port numbers. The wireless router remembers the IP address of the computer that sends a transmission requesting data, so that when the requested data returns through the wireless router, the data is pulled back to the proper computer by way of IP address and port mapping rules. Click the **Port Triggering** button to set up triggered ports, and follow these instructions:

- (1). Enter the Application Name of the trigger.
- (2). Enter the **Outgoing Port Range** used by the application. Check with the Internet application for the port number(s) needed.
- (3). Enter the **Incoming Port Range** used by the application. Check with the Internet application for the port number(s) needed.
- (4). Click the **Apply** button to save your changes. Click the **Cancel** button to cancel your unsaved changes. Click the **Close** button to return to the **Port Forwarding** screen.

Check all the settings and click **Apply** to save them.

# Routing Table

On the **Routing Table** screen, you can set the routing mode and settings of the wireless router. **Gateway** mode is recommended for most users.

- 1 **Dynamic Routing (RIP). IMPORTANT!** This feature is not available in **Gateway** mode. The default setting is **Disable**.

**Dynamic Routing** enables the wireless router to automatically adjust to physical changes in the network's layout and exchange routing tables with other wireless routers. The wireless router determines the network packets' route based on the fewest number of hops between the source and destination.

To enable the **Dynamic Routing** feature, select **Enable**. To disable the **Dynamic Routing** feature for all data transmissions, keep the default setting, **Disable**.

- 2 **Static Routing:** a pre-determined pathway that network information must travel to reach a specific host or network. To set up a static route between the wireless router and another network, select a number from the **Static Routing** drop-down list.
- 3 **Destination IP Address Interface:** the address of the network or host that you want to assign a static route.
- 4 **Subnet Mask:** determines which portion of an IP address is the network portion, and which portion is the host portion.



- 5 Gateway:** the IP address of the gateway device that allows for contact between the wireless router and the network or host.
- 6 Interface:** Depending on where the **Destination IP Address** is located, select **LAN & Wireless** or **Internet (WAN)** from the **Interface** drop-down menu.
- 7** To save your changes, click the **Apply** button. To cancel your unsaved changes, click the **Cancel** button.

For additional static routes, repeat steps 1-4.

- 8 Delete This Entry:** to delete a static route entry do the following.
  - (1) From the **Static Routing** drop-down list, select the **Entry Number** of the static route.
  - (2) Click **Delete This Entry**.
  - (3) To save a deletion, click **Apply** button. To cancel a deletion, click the **Cancel** button.
- 9 Show Routing Table:** click the **Show Routing Table** button to view all of the valid route entries in use. The following fields appear for each entry. Click the **Refresh** button to refresh the data displayed.

**Destination LAN IP:** the address of the network or host to which the static route is assigned.

**Subnet Mask:** this determines which portion of an IP address is the network portion, and which is the host portion.

**Gateway:** the IP address of the gateway device that allows for contact between the wireless router and the network or host.

**Interface:** this interface tells you whether the Destination IP Address is on the **LAN & Wireless** (internal wired and wireless networks), the **WAN** (Internet), or **Loopback** (a dummy network in which one PC acts like a network — necessary for certain software programs).

**10** Click **Apply** to save your settings.

# Appendix

The Appendix has the following sections:

- Specification
- Troubleshooting
- Customer Support
- Compliance Information
- Cleaning & Maintenance
- Limited Warranty

# Specifications

<b>WLAN Standards</b>	<b>IEEE 802.11g*</b> <b>IEEE 802.11b</b>	54, 48, 36, 24, 18, 12, 9, 6 Mbps 11, 5.5, 2, 1 Mbps
<b>Ports</b>	<b>WAN</b> <b>LAN</b>	1 4
<b>Compatibility</b>	<b>Operating Systems</b> <b>Min. Sys. Req.</b>	Windows® 98SE, 2000, XP Professional, XP Home Pentium 200 Mhz or faster processor, 64 MB RAM recommended, CD-ROM drive
<b>Main Board Memory</b>	<b>Flash</b> <b>SDRAM</b>	4MB 8MB
<b>Antenna</b>		Single external antenna
<b>LED Status</b>	<b>LEDs</b>	Power, Standby, Ethernet & Wireless Link/Activity
<b>Networking Interface</b>	<b>Ethernet</b> <b>Wireless</b>	IEEE 802.3 10-base T, IEEE 802.3u 100-base T IEEE 802.11g (2.4Ghz-DSSS)
<b>Channels</b>		1-11 United States, Canada
<b>Output Power</b>		Max 100 mW (after antenna)
<b>Coverage Area†</b>		Up to 100 meters indoors Up to 400 meters outdoors
<b>Wireless Security</b>		64/128 bit WEP Encryption, WPA (Windows XP, SP1 and Windows 2000 SP4 only), and MAC address filtering
<b>Regulatory/Certifications</b>		FCC, IC, UL and Wi-Fi®, and CB
<b>Integrated VPN</b>		Router supports VPN (L2TP and IPSec) traffic. Router also supports reverse VPN functionality.
<b>Physical Dimensions</b>	<b>Product</b>	180 mm x 30 mm x 148 mm (7.08" x 1.18" x 5.83")
<b>Weight</b>	<b>Net</b> <b>Gross</b>	0.8 lb. (0.34 kg) 2.3 lb. (1.04 kg)

\*This mode requires the same technology from the client devices such as the **ViewSonic WPCC100 PC Card Adapter**.

†Performance varies dependent on environment.

# Troubleshooting

**1 If you are using a cable or DSL modem and are experiencing problems connecting to the Internet, do the following:**

- Power off your cable or DSL modem, PC, and the router.
- Power on your modem and wait a few minutes until the modem has established a connection with your ISP.
- Power on the router.
- Power on your PC and attempt to connect to the Internet. For most users, the router's default values should be satisfactory. Some users may need to enter additional information in order to connect to the Internet through their ISP or broadband (cable or DSL) carrier. For example, some cable providers require a specific MAC address for connection to the Internet. To learn more about this, click the Advanced tab and then the MAC Address Clone tab.



## **2 My Wireless Access Point Router will not turn on. No LED's light up.**

- The power is not connected.
- Connect the power adapter to your AP and plug it into the power outlet.

**IMPORTANT!** Only use the power adapter that came with your AP. Using any other adapter may damage your AP Router.

## **3 LAN Connection Problems I can't access my router.**

- Make sure your router is powered on.
- There is no network connection.
- The computer you are using does not have a compatible IP Address. Be sure that the IP Address used on your computer is set to the same subnet as the router. For example, if the router is set to 192.168.1.1, change the IP address of your computer to 192.168.1.15 or another unique IP Address that corresponds to the 192.168.1.X subnet.
- Press the Reset button located on the rear of the router to revert to the default settings.

#### **4 I can't connect to other computers on my LAN.**

- The IP Addresses of the computers are not set correctly. Make sure that each computer has a unique IP Address. If using DHCP through the AP Router, make sure that each computer is enable DHCP function and restart the computer.
- Network cables are not connected properly. Make sure that the Link LED is on. If it is not, try a different network cable.
- Windows network settings are not set correctly. Check each computer for correct network settings.

#### **5 I can't access the Wireless AP Router from a wireless network card.**

- Out of range. Make sure that your computer is within range and free from any strong electrical devices that may cause interference.
- IP Address is not set correctly. Make sure that the Mode, SSID, Channel and encryption settings are set the same on each wireless adapter.
- Check your IP Address to make sure that it is compatible with the Wireless AP Router.

## **6 I forgot my password. What do I do?**

- Press and hold the **Reset** button on the back of the router for 10 seconds. The router then resets to factory defaults. Reconfigure your router all over again.

## **7 *What picture formats can I show with my ViewSonic router?***

- .JPG, GIF, TIF, and BMP

# Compliance Information

## FCC Interference Statement

FCC (Federal Communication Commission) Interference Statement

### Class B Regulations

USA

This equipment complies with the limits for a class B digital device as specified in Part 15 of FCC Rules which provide reasonable protection against harmful interference in a residential area. This equipment generates and uses radio frequency energy, and if not installed and used in accordance with the instructions, may cause harmful interference to radio communications. However, there is no guarantee that interference will not occur in a particular installation. In the unlikely event that there is interference to radio or television reception (which can be determined by turning the equipment off and on), the user is encouraged to try to correct the interference by one or more of the following measures:

- Reorienting or relocating the receiving antenna (radio or television).

- Relocating the equipment with respect to the receiver.
- Consult your dealer or an experienced radio/television technician.
- Any changes or modifications to the equipment not expressly approved by the manufacturer could void the user's authority to operate this equipment.
- Use of a shielded interface cable is required to comply with the Class B limits of Part 15 of FCC rules.

This device complies with Part 15 of the FCC Rules.

Operation is subject to the following two conditions: (1) This device may not cause harmful interference, and (2) this device must accept any interference received, including interference that may cause undesired operation.

**FCC Caution:** Any changes or modifications not expressly approved by the party responsible for compliance could void the user's authority to operate this equipment.

## **Canada**

This digital apparatus does not exceed the Class B limits for radio noise emissions from digital apparatus as set out in the interference-causing equipment standard entitled "Digital Apparatus," ICES-003 of the Department of Communications.

Cet appareil numérique respecte les limites de bruits radioélectriques applicables aux appareils numériques de Classe B prescrites dans la norme sur le matériel brouilleur: "Appareils Numériques," NMB-003 édictée par le ministère des Communications.



This product is in compliance with the standards that the Wi-Fi Alliance has certified.

## Cleaning & Maintenance

- To clean the unit, make sure the unit is turned off.
- Clean the unit in a well-vented room. Allow enough room for air to circulate through the air holes on the unit. Do not pile or stack things on top of or around the unit to prevent air from circulating. This increases the chance of overheating.
- Never spray or pour any liquid directly onto the unit. Do not immerse in water or any liquid.
- Wipe the unit with a clean, soft, lint-free cloth to remove dust and other particles. Dust often.
- If still not clean, apply a small amount of non-ammonia, non-alcohol based glass cleaner onto a clean, soft, lint-free cloth, and wipe the screen.
- Do not attempt to use the unit in a metal closet that prevents the antenna from sending and receiving signals.

# Customer Support

Before contacting ViewSonic Customer Support, check the **Troubleshooting** section for possible solutions to any setup problems you have. For Customer Support or product service, you will need to provide the product serial number.

Country/Region	Website	T = Telephone F = FAX
United States	<a href="http://www.viewsonic.com/support">www.viewsonic.com/support</a>	T: (800) 688-6688 F: (909) 468-1202
Canada	<a href="http://www.viewsonic.com/support">www.viewsonic.com/support</a>	T: (866) 463-4775 F: (909) 468-1202



# Limited Warranty

## Wireless Router Products

### What the warranty covers:

ViewSonic® warrants its Wireless Router products to be free from defects in material and workmanship during the warranty period. If a ViewSonic Wireless Router product proves to be defective in material or workmanship during the warranty period, ViewSonic will, at its sole option, repair or replace the product with a like product. Replacement product or parts may include remanufactured or refurbished parts or components.

VIEWSONIC AND ITS SUPPLIERS DISCLAIM ALL WARRANTIES AND CONDITIONS, EITHER EXPRESS OR IMPLIED, INCLUDING, BUT NOT LIMITED TO, IMPLIED WARRANTIES OF MERCHANTABILITY, FITNESS FOR A PARTICULAR PURPOSE, AND NONINFRINGEMENT.

ANY SOFTWARE THAT MAY BE INCLUDED WITH THIS PRODUCT IS PROVIDED FREE OF CHARGE AND ON AN "AS IS" BASIS, WITHOUT WARRANTY OF ANY KIND, INCLUDING WITHOUT LIMITATION ANY WARRANTIES THAT IT IS FREE OF DEFECTS, MERCHANTABILITY, FIT FOR A PARTICULAR PURPOSE, NON-INFRINGEMENT, OR COMPATIBLE WITH ANY OTHER SOFTWARE. FOR YOUR SPECIFIC RIGHTS AND DUTIES, PLEASE SEE THE END-USER LICENSE AGREEMENT (EULA) CONTAINED WITHIN THE SOFTWARE FOR YOUR PRODUCT.

### How long the warranty is effective:

ViewSonic Wireless Router products are warranted for one (1) year for all parts and one (1) year for all labor from the date of the first consumer purchase.

### Who the warranty protects:

This warranty is valid only for the first consumer purchaser.

### What the warranty does not cover:

1. Software
2. Any product on which the serial number has been defaced, modified or removed.
3. Damage, deterioration or malfunction resulting from:
  - a. Accident, misuse, neglect, fire, water, lightning, or other acts of nature, unauthorized product modification, or failure to follow instructions supplied with the product.
  - b. Repair or attempted repair by anyone not authorized by ViewSonic.
  - c. Damage to or loss of any programs, data or removable storage media.
  - d. Software or data loss occurring during repair or replacement.
  - e. Any damage of the product due to shipment.
  - f. Removal or installation of the product.
  - g. Causes external to the product, such as electrical power fluctuations or failure.
  - h. Use of supplies or parts not meeting ViewSonic's specifications.
  - i. Normal wear and tear.
  - j. Any other cause which does not relate to a product defect.
4. Removal, installation, and set-up service charges.

(Page 1 of 2)

**How to get service:**

1. For information about receiving service under warranty, contact ViewSonic Customer Support. You will need to provide your product's serial number.
2. To obtain service under warranty, you will be required to provide (a) the original dated sales slip, (b) your name, (c) your address, (d) a description of the problem, and (e) the serial number of the product.
3. Take or ship the product freight prepaid in the original container to an authorized ViewSonic service center or ViewSonic.
4. For additional information or the name of the nearest ViewSonic service center, contact ViewSonic.

**Limitation of implied warranties:**

THERE ARE NO WARRANTIES, EXPRESS OR IMPLIED, WHICH EXTEND BEYOND THE DESCRIPTION CONTAINED HEREIN INCLUDING THE IMPLIED WARRANTY OF MERCHANTABILITY AND FITNESS FOR A PARTICULAR PURPOSE.

**Exclusion of damages:**

VIEWSONIC'S LIABILITY IS LIMITED TO THE COST OF REPAIR OR REPLACEMENT OF THE PRODUCT. VIEWSONIC SHALL NOT BE LIABLE FOR:

1. DAMAGE TO OTHER PROPERTY CAUSED BY ANY DEFECTS IN THE PRODUCT, DAMAGES BASED UPON INCONVENIENCE, LOSS OF USE OF THE PRODUCT, LOSS OF DATA, LOSS OF TIME, LOSS OF PROFITS, LOSS OF BUSINESS OPPORTUNITY, LOSS OF GOODWILL, INTERFERENCE WITH BUSINESS RELATIONSHIPS, OR OTHER COMMERCIAL LOSS, EVEN IF ADVISED OF THE POSSIBILITY OF SUCH DAMAGES.
2. ANY OTHER DAMAGES, WHETHER INCIDENTAL, CONSEQUENTIAL OR OTHERWISE.
3. ANY CLAIM AGAINST THE CUSTOMER BY ANY OTHER PARTY.

**Effect of state law:**

This warranty gives you specific legal rights, and you may also have other rights which vary from state to state. Some states do not allow limitations on implied warranties and/or do not allow the exclusion of incidental or consequential damages, so the above limitations and exclusions may not apply to you.

**ViewSonic Wireless Router Products Warranty (V1.0)**

**Release Date: June 3, 2004**

**(Page 2 of 2)**

## Free Manuals Download Website

<http://myh66.com>

<http://usermanuals.us>

<http://www.somanuals.com>

<http://www.4manuals.cc>

<http://www.manual-lib.com>

<http://www.404manual.com>

<http://www.luxmanual.com>

<http://aubethermostatmanual.com>

Golf course search by state

<http://golfingnear.com>

Email search by domain

<http://emailbydomain.com>

Auto manuals search

<http://auto.somanuals.com>

TV manuals search

<http://tv.somanuals.com>