

USE/INSTALLATION INSTRUCTIONS

VIKING RANGE CORPORATION
111 Front Street
Greenwood, Mississippi 38930 USA
(662) 455-1200

VRBD/VUBD 24" W. BEVERAGE DISPENSER

Retain for Future Reference

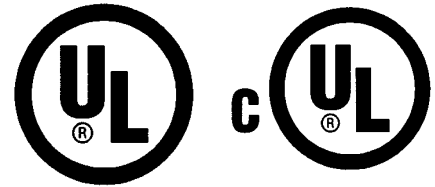

IMPORTANT - PLEASE READ AND FOLLOW

- Before beginning, please read these instructions completely and carefully.
- Do not remove permanently affixed labels, warnings, or plates from the product. This may void the warranty.
- The installer should leave these instructions with the consumer for future reference.

GENERAL INFORMATION

1. **ALWAYS** connect CO₂ gas cylinder to reducing valve or regulator
2. **NEVER** connect gas cylinder directly to keg.
3. **ALWAYS** secure gas cylinder in upright position.
4. **ALWAYS** keep gas cylinder away from heat.
5. **NEVER** drop or throw gas cylinder.
6. **ALWAYS** ventilate after CO₂ leakage.
7. Gas cylinders should be stored in the coolest part of the room, preferably at 70°F., and securely fastened in the upright position before the primary regulator is attached to the cylinder

! WARNING

CO₂ CAN BE DANGEROUS

If it becomes difficult to breathe and your head starts to ache, abnormal concentrations of carbon dioxide may be present in the area. Leave the room immediately.

BEER DISPENSING KIT CONSISTS OF:

- Draft Tower Assembly
- Drain Hose
- Drain Container
- Keg Coupler
- Air Line with Clamps
- Single Gauge Regulator
- Filled 5 lb. CO₂ Cylinder

TOOLS NEEDED:

- Crescent Wrench
- Pliers
- Screwdriver

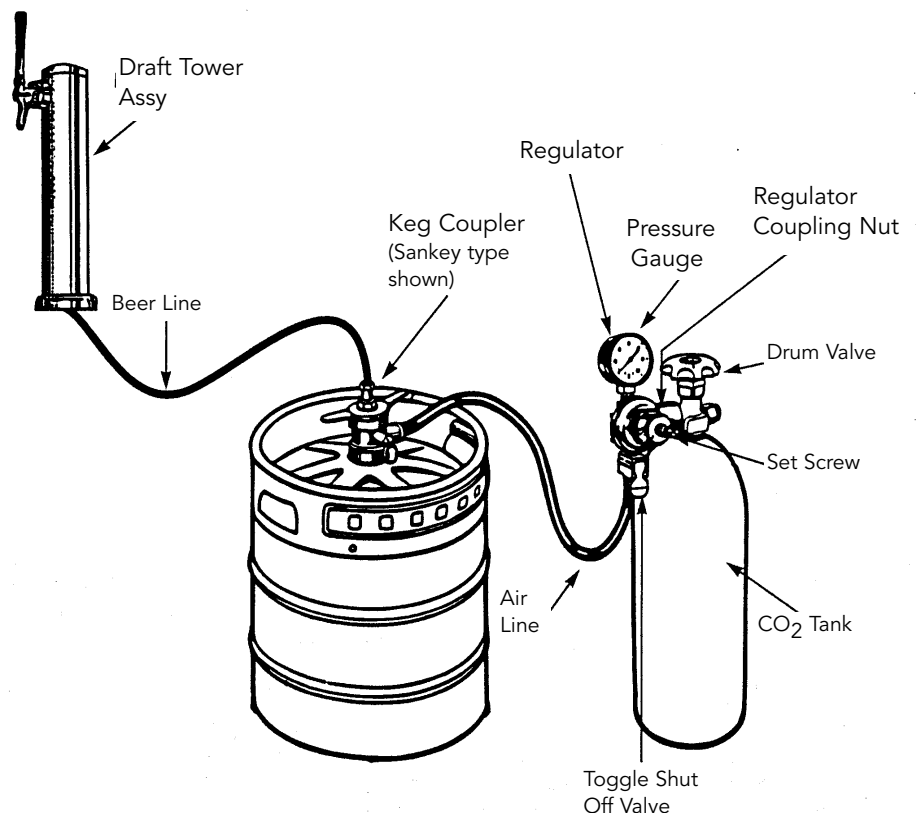

41006170 Rev. F

Proper Disposal of Your Old Refrigeration Product

⚠ WARNING

Suffocation Hazard

Remove doors from your old refrigerator.

Failure to do so can result in child entrapment, which can cause death or brain damage

IMPORTANT: Child entrapment and suffocation are not problems of the past. Junked or abandoned refrigerators are still dangerous, even if they will sit for "just a few days." If you are getting rid of your refrigeration product, please follow the instructions below to help prevent accidents.

BEFORE YOU THROW AWAY YOUR OLD REFRIGERATION PRODUCT:

- Take off the doors.
- Leave the shelves in place so that children may not easily climb inside.

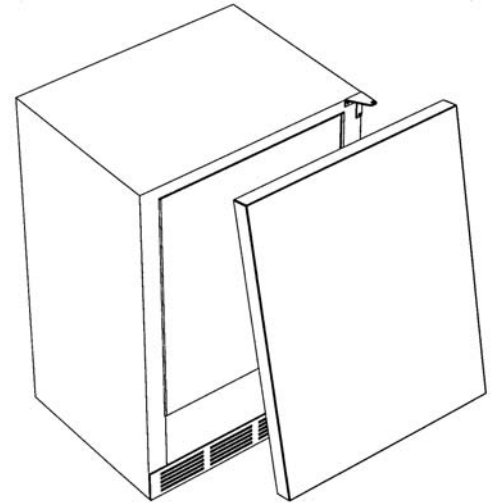

BUILT-IN INSTALLATION

Select Location

The proper location will ensure peak performance of your appliance. Choose a location where the unit will be out of direct sunlight and away from heat sources. Units with fan cooled condensers can be built-in.

Unit should be operated in a properly ventilated area with ambient temperatures above 40°F (4.4°C) and below 110°F (43°C). Installation should be such that the cabinet can be moved for servicing if necessary.

Cabinet Clearance

Ventilation is required from the bottom front section of the unit. **Keep this area open and clear of any obstructions.** The adjacent cabinets and countertop can be built around the unit as long as no top trim or counter top is installed lower than the top of the hinge.

ELECTRICAL CONNECTION

Electrical Requirements

A 115 volt, 60 Hz, AC only 15 amp fused electrical supply is required. (A time delay fuse or circuit breaker is recommended.) It is recommended that a separate circuit, serving only this appliance, be provided.

- ELECTRICAL GROUND IS REQUIRED ON THIS APPLIANCE.**
- DO NOT UNDER ANY CIRCUMSTANCES REMOVE THE POWER SUPPLY CORD GROUND PLUG.**
- DO NOT USE AN EXTENSION CORD.**

Recommended Grounding Methods

For your personal safety, this unit must be grounded. This appliance is equipped with a power supply cord having a 3-prong grounding plug. To minimize possible shock hazard, the cord must be plugged into a mating 3-prong grounding type wall receptacle grounded in accordance with the National Electrical Code and local codes and ordinances. If the circuit does not have a grounding type receptacle, it is the responsibility and obligation of the customer to exchange the existing receptacle in accordance with the National Electrical Code and applicable local codes and ordinances. The third ground plug **SHOULD NOT**, under any circumstances, be cut or removed. All UL listed refrigerated products are equipped with this type of plug.

Power Supply
with 3-prong
grounding plug

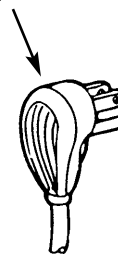

Grounding type wall
receptacle

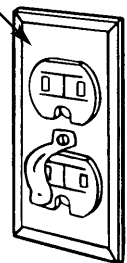

⚠ WARNING

Electrical Shock Hazard
Do not splash or spray water from a hose on a refrigerated unit. Doing so may cause an electrical shock which may result in severe injury or death.

CASTERS

Your beverage dispenser is equipped with four casters. the front two casters can be locked.

For built-in applications, the four casters can be removed by removing the nut located inside the dispenser cabinet and then pulling the threaded caster spindle through the base of the unit.

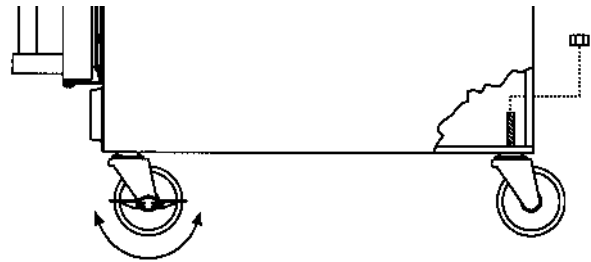

Lock and Unlock

CABINET CUTOUT - FREESTANDING MODELS

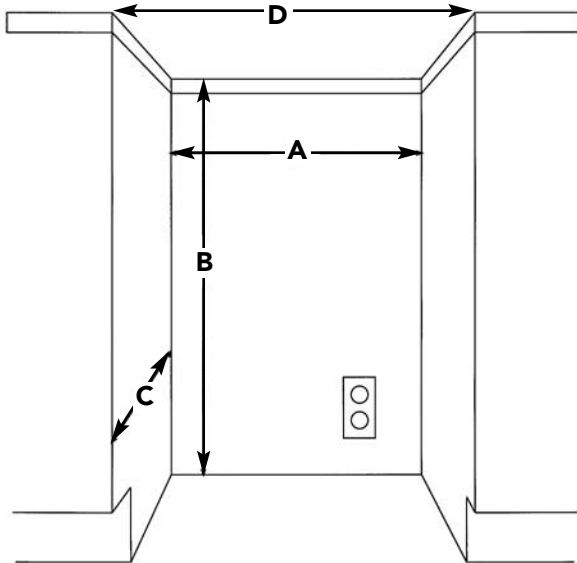

A	24" (61.0 cm)*
B	35 9/16" (90.3 cm)**
C	24" (61.0cm)
D	24 3/4" (62.9 cm)

*24" width for cabinet only. 24 1/4" (61.6 cm) needed for cabinet and door width clearance if door is recessed between cabinets.

**35 9/16" (90.3 cm) height is without casters mounted to unit. 39 3/4" (101.0cm) needed for height clearance with casters.

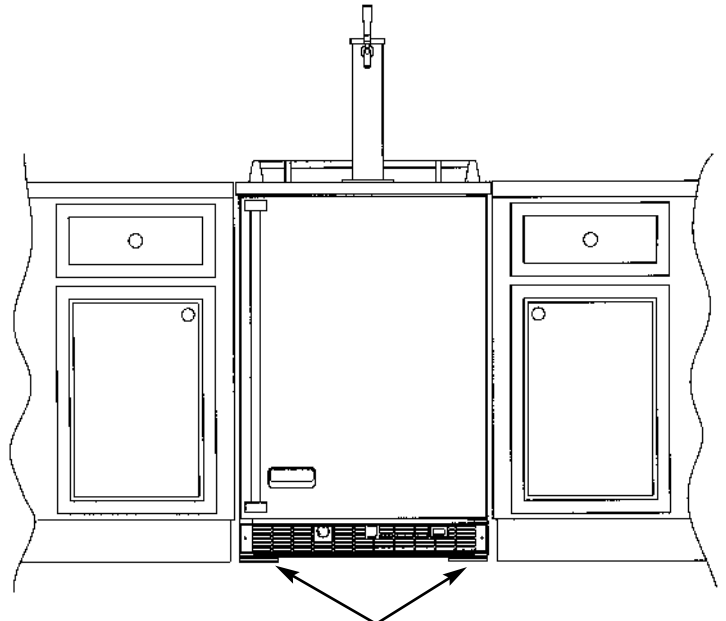
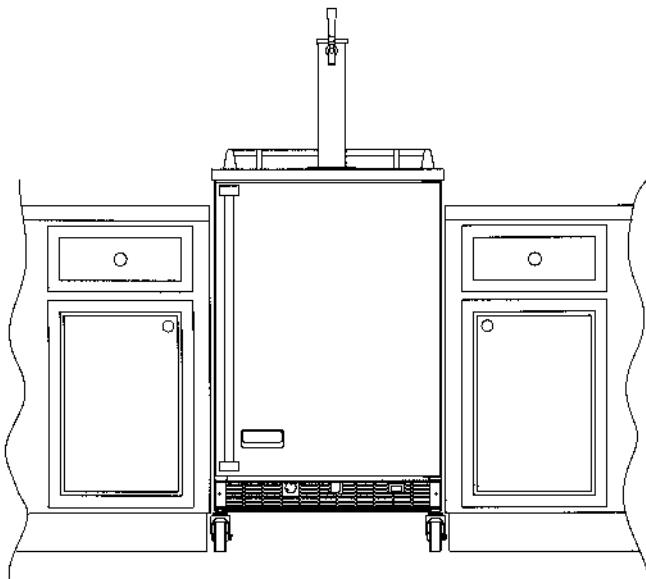

If removing the casters is necessary for installation, the unit should be raised off the ground. This should be done with an approved material.
(Consult local building codes for approved material.)

LEVEL UNIT

1. After placing unit in position, check to make certain the unit is level side to side and front to back.
2. Accurate leveling is essential for proper operation.

DIMENSIONS - FREESTANDING MODELS

FRONT

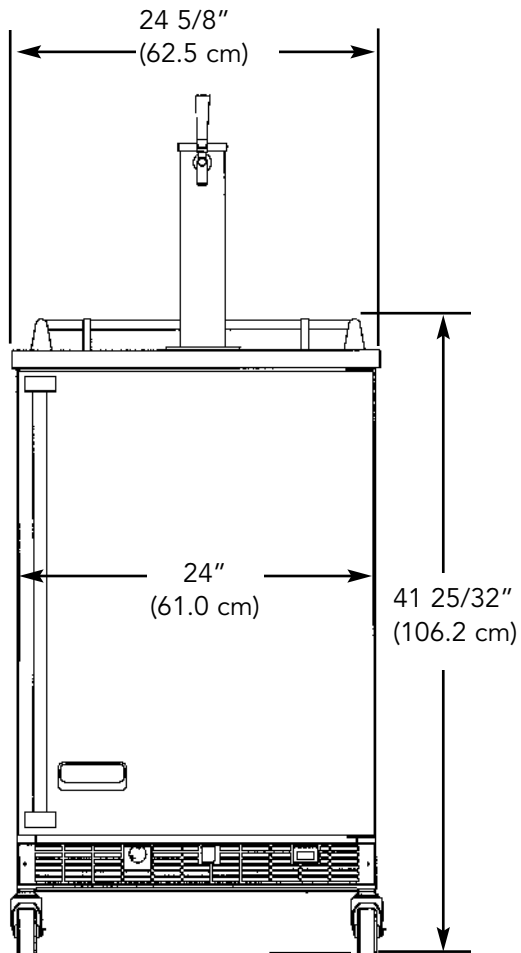

SIDE

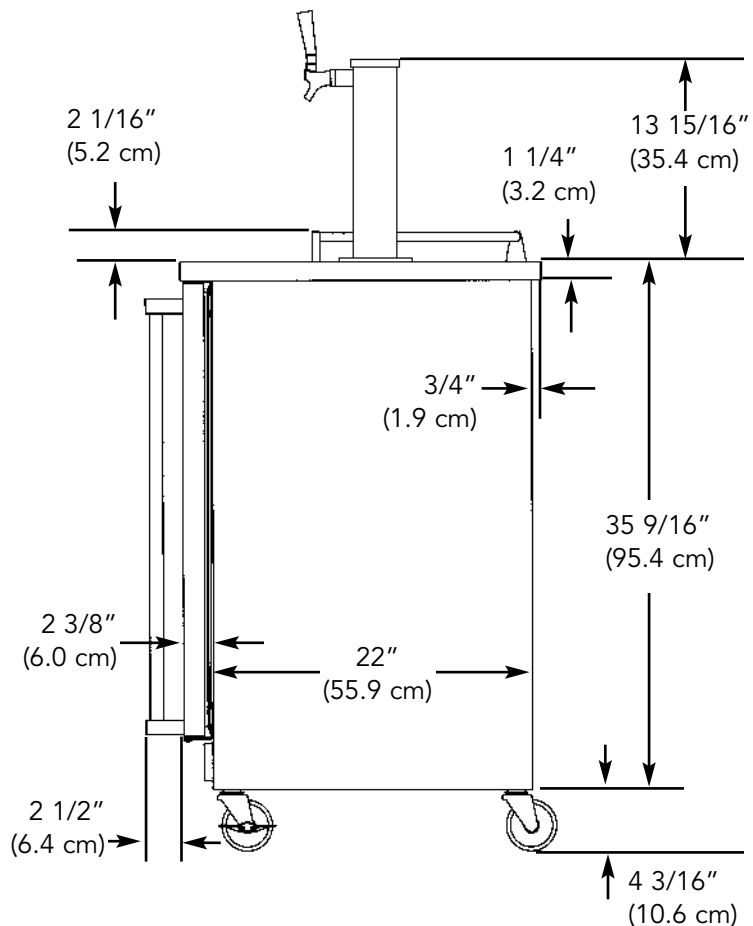

TOP

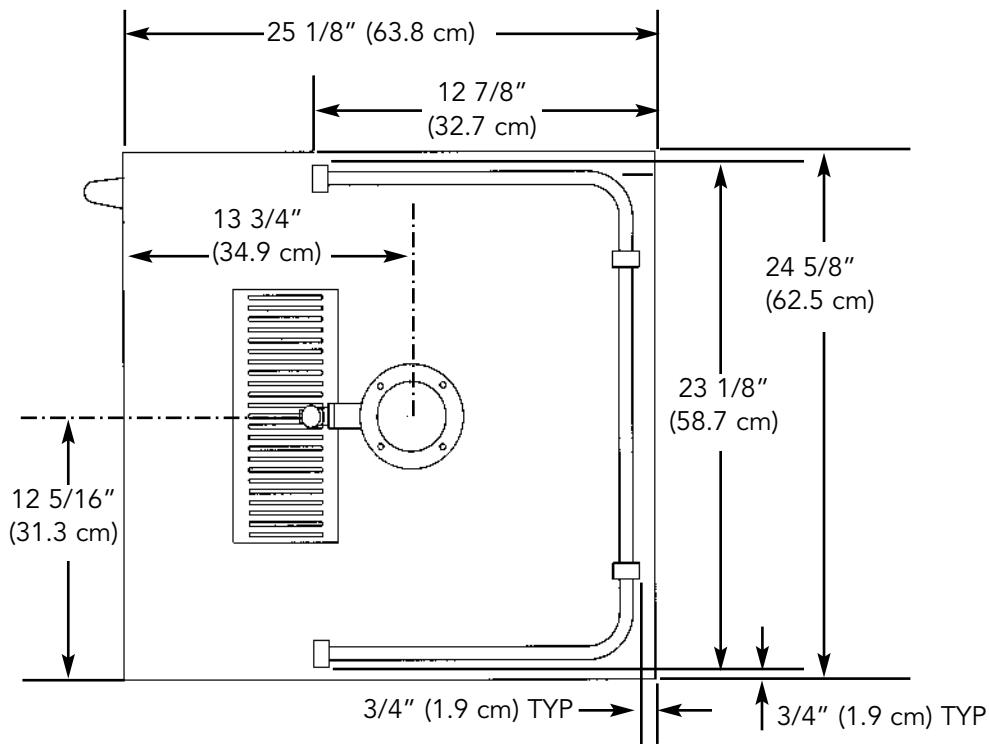

CABINET CUTOUT - UNDERCOUNTER MODELS

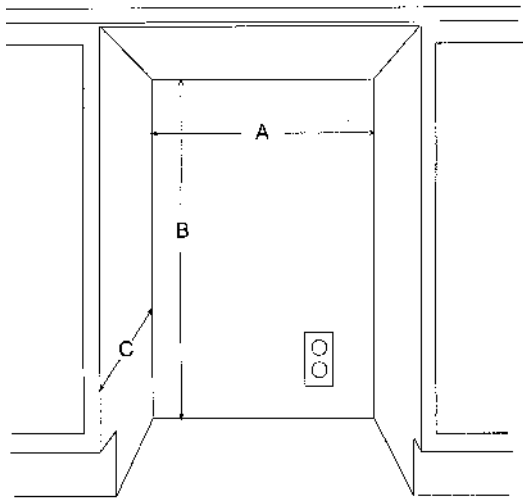

A	24" (61.0 cm)*
B	Min. 34 1/8" (87.9 cm) Max. 35 1/8" (89.2 cm)
C	24" (61.0 cm)

*24" width for cabinet only. 24 1/4" (61.6 cm) needed for cabinet and door width clearance if door is recessed between cabinets.

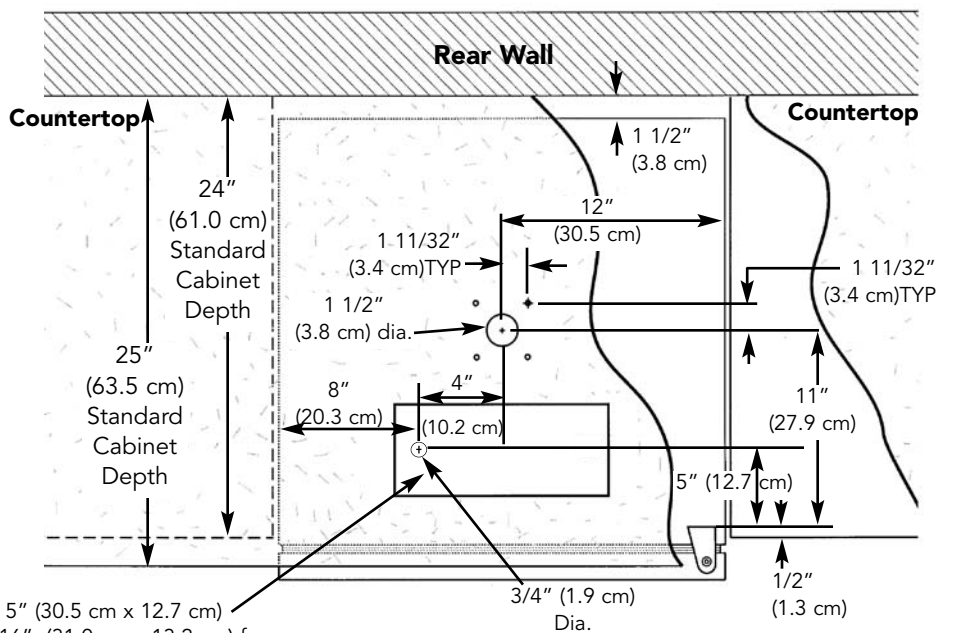

*Actual dimension of drain pan is 12" x 5" (30.5 cm x 12.7 cm)
This area should be cut 12 3/16" x 5 3/16" (31.0 cm x 13.2 cm) for clearance

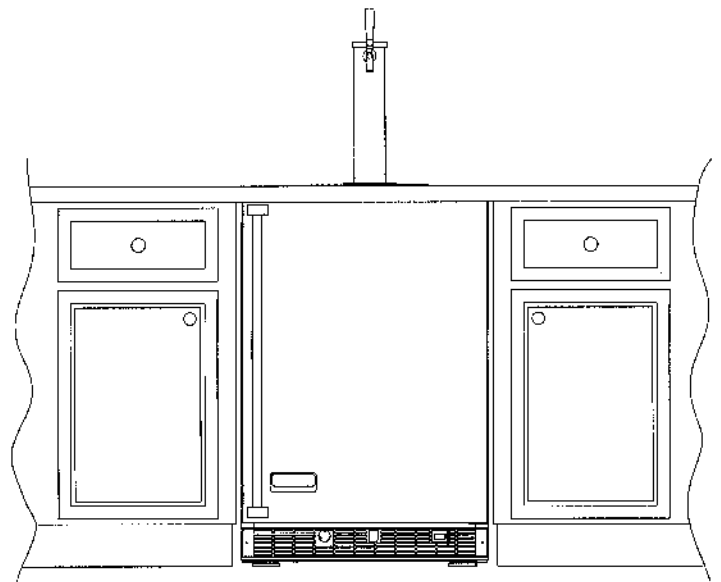
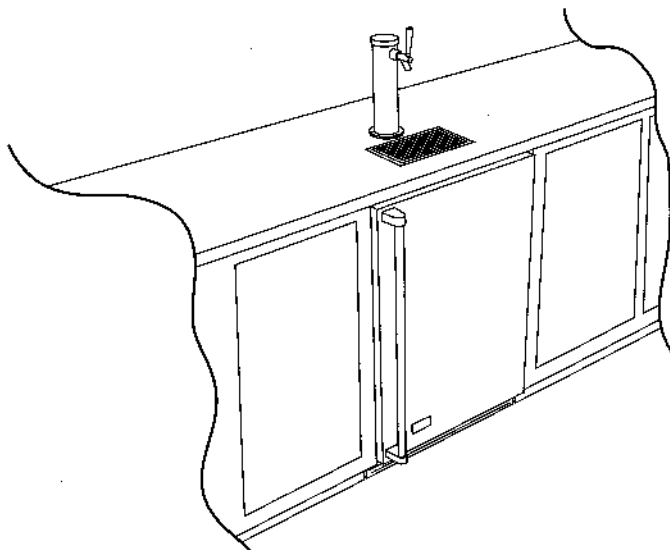

DIMENSIONS - UNDERCOUNTER MODELS

FRONT

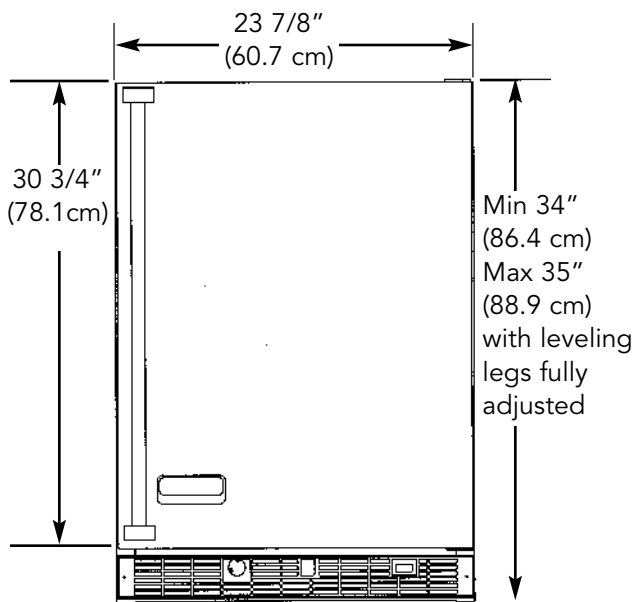

SIDE

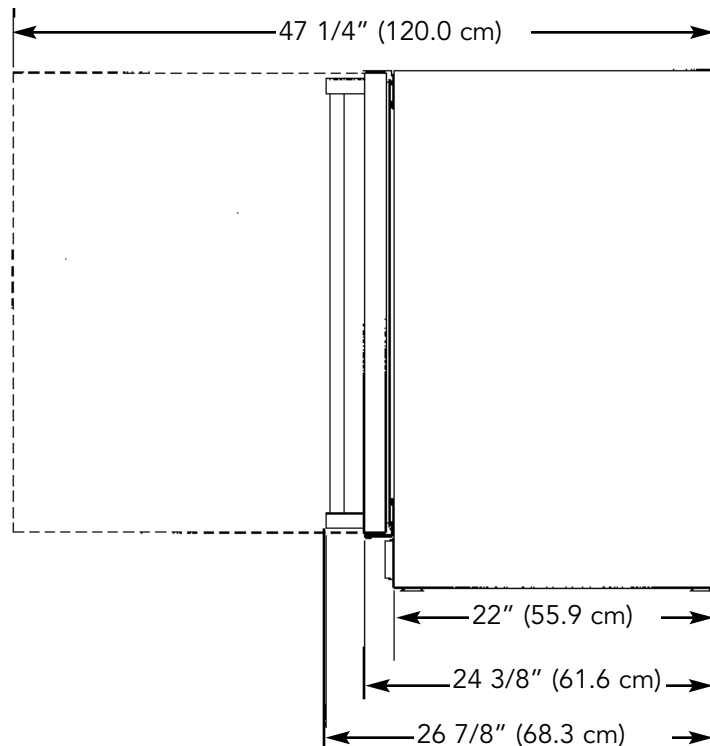

TOP

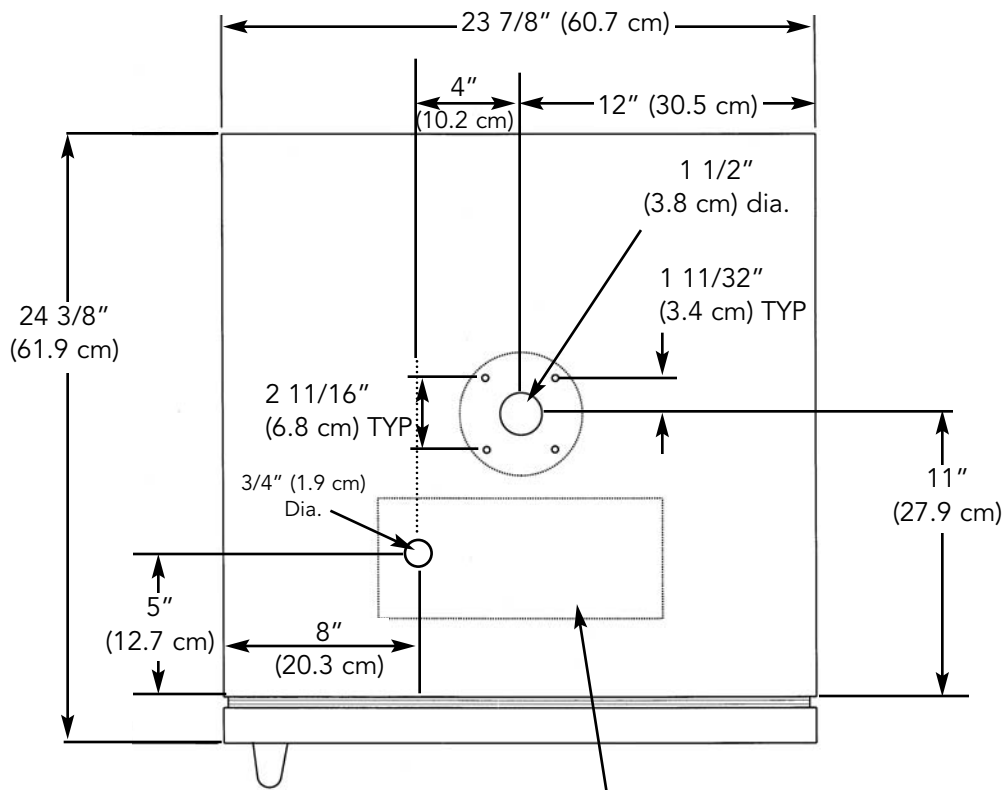

*Actual dimension of drain pan is 12" x 5" (30.5 cm x 12.7 cm)

ASSEMBLY

1. Screw the black faucet knob onto the faucet.

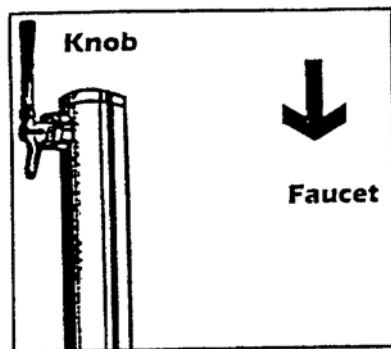

3. Attach the clear beverage line coming from the draft tower to the keg coupler. Use the black washer inside the hex nut and tighten securely with crescent wrench.

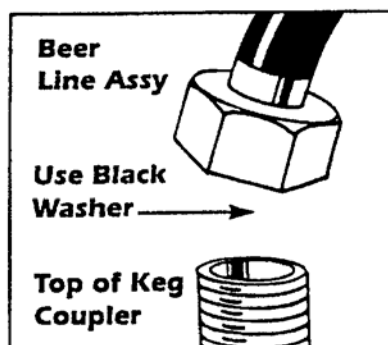

5. Attach one end of the red air hose to the hose barb on the CO₂ regulator, using one of the two snap clamps provided. (Use pliers to snap the clamp tight to assure that there is no gas leak.)

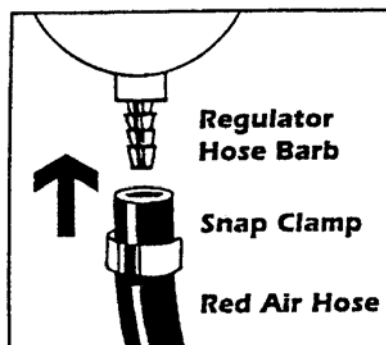

7. Fasten the other end of the red air line to the keg coupler using the remaining snap clamp.

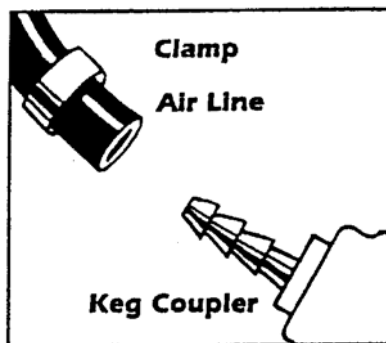

2. Insert the clear beverage line from the tower through the hole in the top of the unit. Mount the draft tower onto the refrigerator using the (4) furnished screws and (1) mounting gasket.

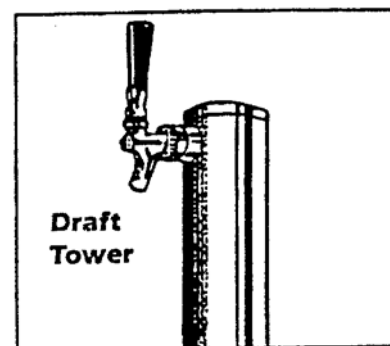

4. Fasten the CO₂ regulator to the CO₂ tank, tightening the CO₂ nut securely, using the gray fiber washer between the regulator nut and the cylinder.

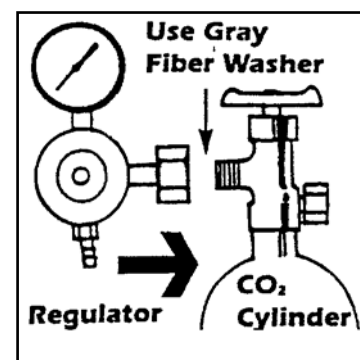

6. Place the CO₂ cylinder and regulator in the right corner of the refrigerator.

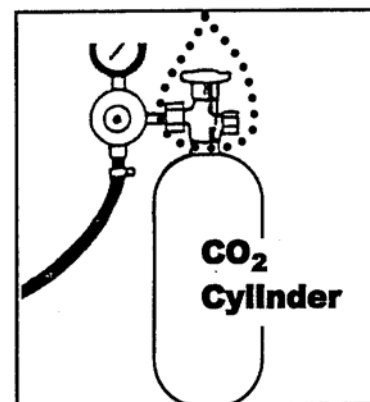

NOTE: It is important that the cylinder be kept in an upright position to operate efficiently. Secure the cylinder using the provided chain by looping the chain around the cylinder valve and regulator.

CO₂ REGULATOR

1. Low pressure gauge.
(reads the amount of internal keg pressure)
2. Adjustment lock nut.
3. Regulator adjustment screw
(after keg is tapped, screw clockwise until low pressure gauge indicates between 12 & 14 lbs.)
4. Shut-off valve.
5. CO₂ Nut (use fiber CO₂ washer)

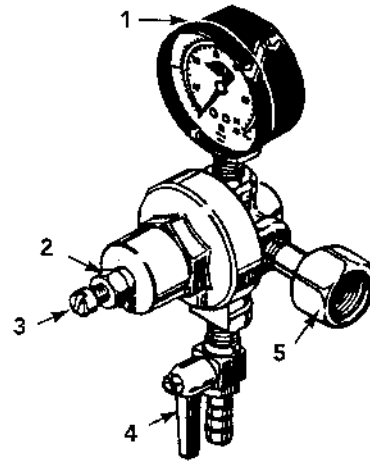

How to Replace an Empty CO₂ Cylinder

1. Close cylinder valve by turning clockwise "A".
2. Unscrew adjustment screw (counter-clockwise) "B" as far as it will go.
3. Remove the regulator from empty cylinder "E".
4. Remove dust cap from new cylinder "E". Open and close valve "A" quickly to blow dust from outlet.
5. With cylinder valve "A" in closed position, reattach regulator to cylinder at "E". Be sure to include the CO₂ washer.
6. Open valve "A" all the way. (This is important because this cylinder valve seals in two places.)
7. Readjust regulator pressure "B" and open valve "C".

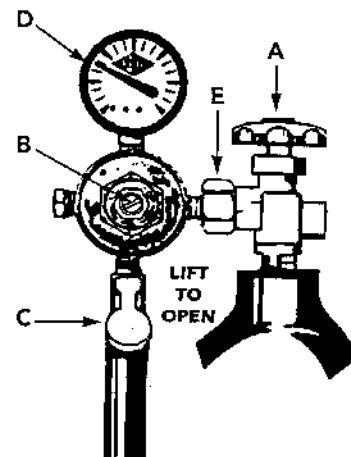

TAPPING PROCEDURES

There are two keg sizes:

- 1) the quarter barrel containing 7 3/4 gallons or approximately 3 1/2 cases of 12 ounce bottles or
- 2) the half barrel containing 15 1/2 gallons or approximately 7 cases.

APPROXIMATE MEASUREMENTS REQUIRED TO TAP MOST KEGS

	Quarter Barrel	Half Barrel
Height	17 - 21 inches	25 - 29 inches
Diameter	16 - 20 inches	18 - 22 inches
Weight	80 - 85 pounds	160 - 180 pounds

SANKEY TYPE KEG COUPLER

(Taps all Coors™, Miller™ and Budweiser™ kegs)

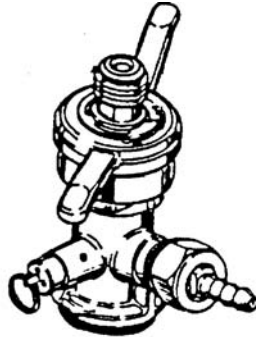

1. Align lug locks on tavern head with lug housing in top of key; insert tavern head.

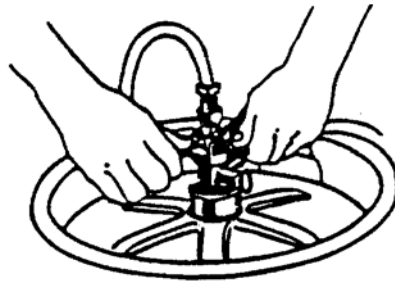

2. Turn tavern head handle 1/4 turn clockwise; the tavern head is now secured to keg.



3. Rotate on/off valve handle 1/4 turn clockwise to open beer and CO₂ ports in keg. The keg is now tapped.

TWIN PROBE KEG TAPS

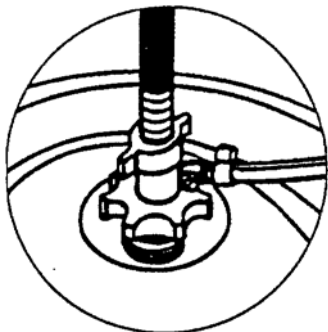

Insert Probes

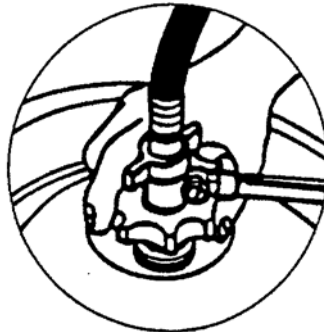

Screw Tavern Knob Hand Tight

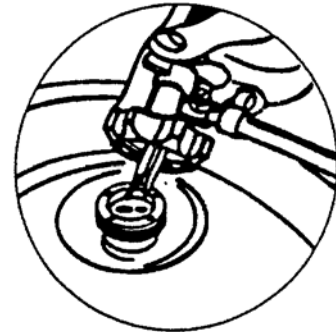

Turn on Pressure and Draw Beer



CO₂ Cylinders (It is recommended to have an extra cylinder on hand)

Cylinder	Dia.	Ht.	Empty Weight	Full Weight
5 lbs.	5"	17-1/2"	12-1/2 lbs.	17-1/2 lbs.

DRAIN HOSE AND CONTAINER

Before using the beverage dispenser, make sure the drain hose and container are properly installed.

1. Attach the hose to the drain.
2. Attach the container to the hose.
3. Empty the container when it becomes full.
4. Rinse both the hose and container before reattaching to the beverage dispenser.

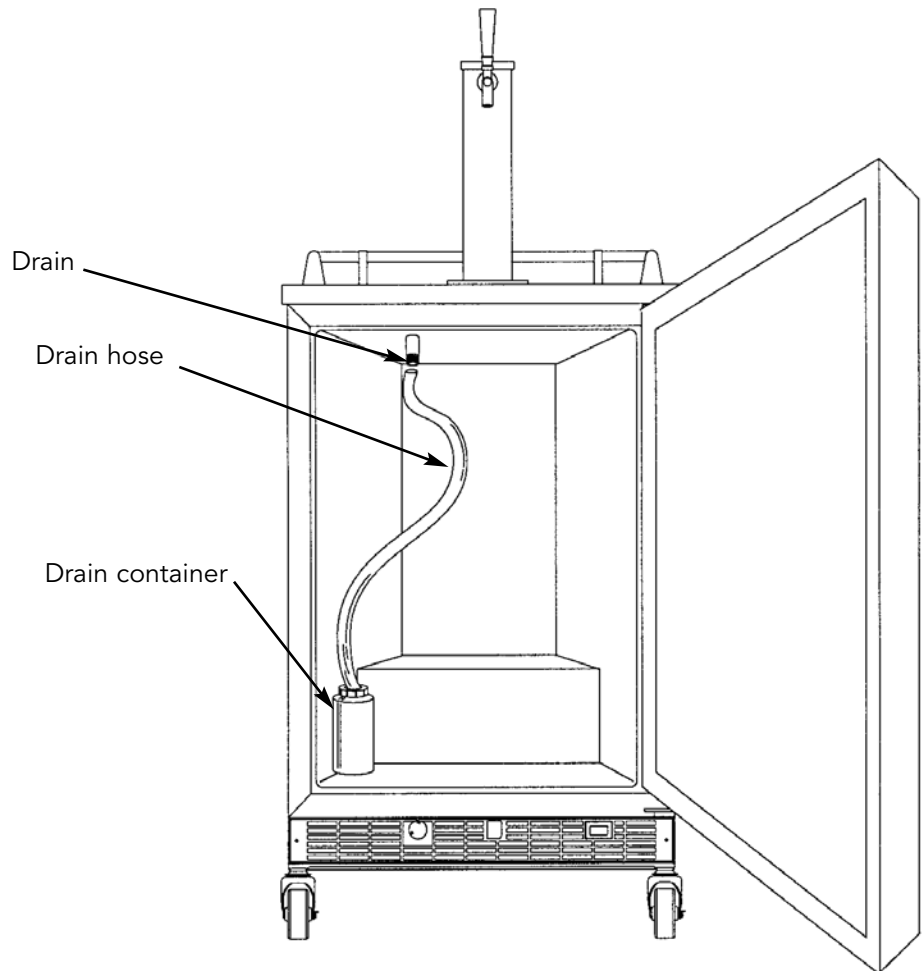

FINAL PREPARATION

- All stainless steel parts should be wiped with hot soapy water. If buildup occurs, do not use steel wool, abrasive cloths, cleaners, or powders. If it is necessary to scrape stainless steel to remove encrusted materials, soak with hot, wet cloths to loosen the material, then use a wood or nylon scraper. Do not use a metal knife, spatula, or any other metal tool to scrape stainless steel; scratches are almost impossible to remove.

GENERAL TIPS AND SUGGESTIONS

- After making a temperature change, allow 24 hours for your unit to reach a new temperature setting.
- The motor will start and stop often. It must do this to maintain the temperature you select.
- Unplug the appliance before working on anything with the electrical system.
- Exercise caution when sweeping, vacuuming, or mopping near the front of the unit. Damage to the grill can occur.
- For all cleaning, mix 2 tablespoons baking soda with 1 quart warm water or use mild soapy and water solution. Do not use strong cleaners or scouring powder or pads.
- Keep your appliance out of direct sunlight.
- Do not splash or spray water on or under the unit.
- Clean you appliance's condenser periodically to maintain proper cooling performance.

WIRING DIAGRAM 24" W. REFRIGERATED BEVERAGE DISPENSER

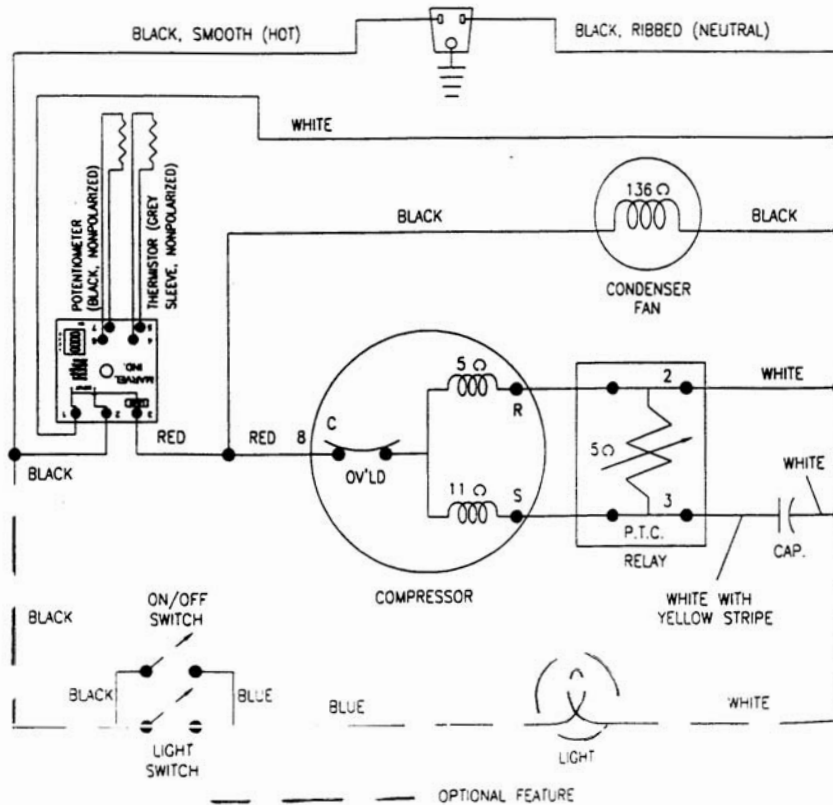

WARNING: ELECTRICAL GROUNDING INSTRUCTIONS

This appliance is equipped with a three prong grounding plug for your protection against shock hazard and should be plugged directly into a properly grounded three prong receptacle. Do not cut or remove the grounding prong from this plug.

OPERATING INSTRUCTIONS

SETTING THE CONTROL

**NOTE: The control is factory set for the ideal draft beer temperature - 38°F (3.3°C).
(Temperature setting may need adjustments depending on ambient temperature.)**

Initially set the cold control knob midway between the numbers. Allow at least 48 hours for the unit to stabilize before making any adjustments to the initial temperature setting. The higher the number, the cooler the temperature.

The temperature control knob is located at the bottom front of the cabinet, just behind the square opening near the middle of the grill.

Draft beer is not pasteurized, so it must be kept cold - preferably around 38°F (3.3°C). Temperatures above 45°F (7.2°C) may cause the beer to become wild, turn sour and cloudy. Draft beer should be consumed within 30 days, as it is not pasteurized and loses its original brewery fresh taste and aroma the older it gets.

HOW TO DRAW THE PERFECT GLASS OF BEER

1. Start with a clean beer glass that has been wetted in cold water. Place the glass at a 45° angle, one inch below the faucet. **Do not let the glass touch the faucet.** Open the faucet all the way.

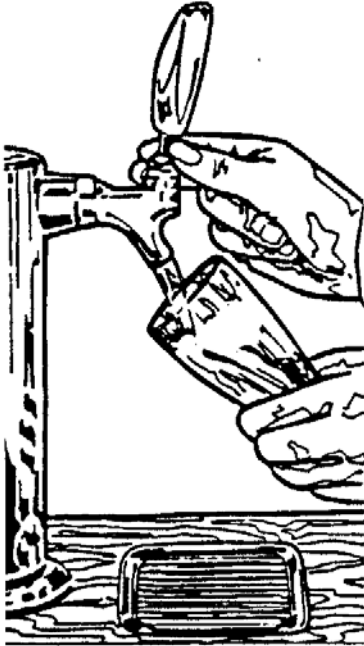

2. After the glass has reached half full, gradually bring the glass to an upright position.

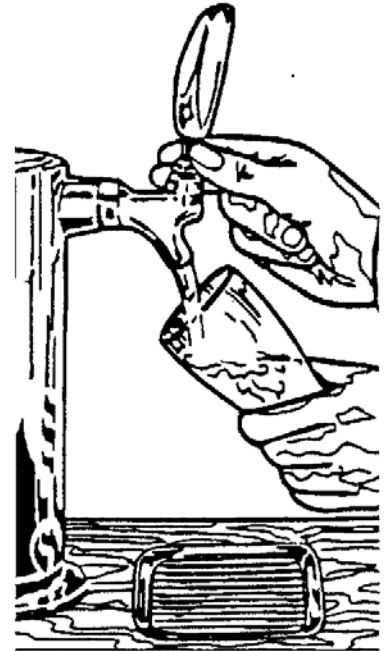

3. Let the remaining beer run straight down the middle. This insures proper release of CO₂ by producing a 3/4" to 1" foam head.



4. Close the faucet completely and quickly.

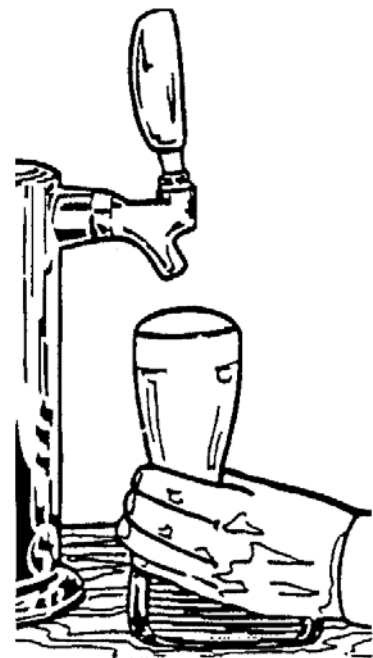

COMMON DRAFT PROBLEMS

DESCRIPTION	CAUSES
<p>Wild Beer Beer, when drawn, is all foam, or too much foam and not enough liquid beer.</p>	<p>Beer drawn improperly Creeping regulator Applied pressure is set too high Hot spots in line Use of non-insulated beer line Beer runs are too long for proper cooling Tapped into a warm keg Cooler malfunctioning Kinks, dents, twists, or other obstructions in line Faucets in bad, dirty or worn condition</p>
<p>Cloudy Beer When beer in glass appears hazy, not clear</p>	<p>Frozen or nearly frozen beer Old beer Beer that has been unrefrigerated for long periods of time Dirty glass Dirty faucet Unrefrigerated foods placed on top of cold keg Contaminated air source</p>
<p>Flat Beer Foamy head disappears quickly; beer lacks usual zestful brewery fresh flavor</p>	<p>Dirty glasses Sluggish regulator Applied pressure is set too low CO₂ is turned off at night Contaminated air source (associated with compressed air) Moisture in air system Beer too cold Loose tap or vent connections</p>
<p>False Head Large soap-like bubbles, head dissolves very quickly</p>	<p>Applied pressure required does not correspond to beer temperature Small beer line into a large faucet shank Beer lines warmer than beer in keg Dry glasses Improper pour</p>
<p>Unpalatable Beer Off-Taste</p>	<p>Dirty or old beer lines Dirty faucet Contaminated air source, or unfiltered Unsanitary bar conditions</p>

ENERGY SAVING TIPS

Ways to save power, save money, and still enjoy your beverage dispenser.

- Reduce door openings.
- Close the door as soon as you can.
- Keep the coils on bottom of the refrigerator clean.
- Adjust the temperature control to a warmer setting when practical.
- Keep unit away from the stove or other heat sources.

CLEANING AND MAINTENANCE

Condenser

The condenser tubing under the cabinet for forced air units does not require frequent cleaning. However, satisfactory cooling depends on adequate ventilation over the condenser. Be sure that nothing obstructs the air flow openings in the lower front of the cabinet. At least once or twice a year brush or vacuum lint and dirt from the condenser for efficient performance by unscrewing the grill on the bottom front of the cabinet.

Cabinet

The painted cabinet can be washed with mild soap and water and thoroughly rinsed with clear water. Never use abrasive scouring powders.

Interior and Door Gasket

Wash interior compartment with mild soap and water. Mix 2 tablespoons of baking soda with one quart of warm water. Do not use an abrasive powder, solvent, polish cleaner or undiluted detergent.

SERVICE INFORMATION

It is assumed that your beverage dispenser has been properly installed in accordance with all specifications and local codes. If your beverage dispenser should fail to operate, review the common draft problems before calling for service.

If service is required:

1. Call your dealer or authorized service agency. The name of the authorized service agency can be obtained from the dealer or distributor in your area.
2. Have the following information readily available:
 - Model Number
 - Serial Number
 - Date of purchase
 - Name of dealer from whom purchased.
3. Clearly describe the problem that you are having.

If you are unable to obtain the name of an authorized service agency, or if you continue to have service problems, contact Viking at (888) 845-4641 or write to:

VIKING PREFERRED SERVICE
111 Front Street
Greenwood, Mississippi 38930 USA

Record the information indicated below. You will need it if service is ever required. The model and serial number for your beverage dispenser is located on the front of the unit at the base of the door frame.

Model Number _____ Serial Number _____

Date of Purchase _____ Date Installed _____

Dealer's Name _____

Address _____

If service is requires installation of parts, use only authorized parts to ensure protection under the warranty.
This manual should remain with the beverage dispenser for future reference.

PROFESSIONAL SERIES 24" W. BEVERAGE DISPENSER WARRANTY

ONE YEAR FULL WARRANTY

Built-in/freestanding beverage dispensers and all of their components and accessories, except as detailed below*, are warranted to be free from defects in material or workmanship under normal household use for a period of one (1) year from the date of original retail purchase. Viking Range Corporation, warrantor, agrees to repair or replace, at its option, any part which fails or is found to be defective during the warranty period.

*Painted and decorative items are warranted to be free from defective materials or workmanship for a period of ninety (90) days from the date of original retail purchase. ANY DEFECTS MUST BE REPORTED TO THE SELLING DEALER WITHIN NINETY (90) DAYS FROM DATE OF ORIGINAL RETAIL PURCHASE.

FIVE YEAR LIMITED WARRANTY

Any sealed refrigeration system component, as listed below, is warranted to be free from defective materials or workmanship in normal household use during the second through the fifth year from the date of original retail purchase. Viking Range Corporation, warrantor, agrees to repair or replace, at its option, any part which fails or is found to be defective during the warranty period.

Sealed Refrigeration System Components: Compressor, Evaporator, Condenser, Connecting Tubing, Dryer/Strainer

It is recommended that in temperatures above 100°F (37.8°C) and below 40°F (4.4°C) the unit be shut off. The normal operating range for the unit is between 60°F (15.6°F) and 100°F (37.8°C).

NINETY (90) DAY RESIDENTIAL PLUS WARRANTY This warranty applies to applications where use of the product extends beyond normal residential use. Examples are, but not limited to, bed and breakfasts, fire stations, private clubs, churches, etc. This warranty excludes all commercial locations such as restaurants, food service locations and institutional food service locations.

This warranty extends to the original purchaser of the product warranted hereunder and to each transferee owner of the product during the term of the warranty.

This warranty shall apply to products purchased and located in the United States and Canada. Products must be purchased in the country where service is requested. Warranty labor shall be performed by an authorized Viking Range Corporation service agency or representative. Warranty shall not apply to damage resulting from abuse, accident, natural disaster, loss of electrical power to the product for any reason, alteration, improper installation, improper operation or repair or service to the product by anyone other than an authorized Viking Range Corporation service agency or representative. Warranty shall not apply to damage resulting from indoor units being used in outdoor situations. This warranty does not apply to commercial usage. Warrantor is not responsible for consequential or incidental damage whether arising out of breach of warranty, breach of contract, or otherwise. Some jurisdictions do not allow the exclusion or limitation of incidental or consequential damages, so the above limitation or exclusion may not apply to you.

Owner shall be responsible for proper installation, providing normal care and maintenance, providing proof of purchase upon request, and making the appliance reasonably accessible for service. If the product or one of its component parts contains a defect or malfunction during the warranty period, after a reasonable number of attempts by the warrantor to remedy the defects or malfunctions, the owner is entitled to either a refund or replacement of the product or its component part or parts. Replacement of a component part includes its free installation. Warrantor's liability on any claim of any kind, with respect to the goods or services covered hereunder, shall in no case exceed the price of the goods or service or part there of which gives rise to the claim.

WARRANTY SERVICE: Under the terms of this warranty, service must be performed by a factory authorized Viking Range Corporation service agent or representative. Service will be provided during normal business hours, and labor performed at overtime or premium rates shall not be covered by this warranty. To obtain warranty service, contact the dealer from whom the product was purchased, an authorized Viking Range Corporation service agent, or Viking Range Corporation. Provide model and serial number and date of original purchase. For the name of your nearest authorized Viking Range Corporation service agency, call the dealer from whom the product was purchased or Viking Range Corporation. **IMPORTANT:** Retain proof of original purchase to establish warranty period.

The return of the Owner Registration Card is not a condition of warranty coverage. You, however, should return the Owner Registration Card so that Viking Range Corporation can contact you should any question of safety arise which could affect you.

Any implied warranties of merchantability and fitness applicable to the above described undercounter refrigerator are limited in duration to the period of coverage of the applicable express written limited warranties set forth above. Some jurisdictions do not allow limitations on how long an implied warranty lasts, so the above limitation may not apply to you. This warranty gives you specific rights, and you may also have other rights which may vary from jurisdiction to jurisdiction.

Viking Range Corporation
111 Front Street • Greenwood, Mississippi 38930 USA • (662) 455-1200
Specifications subject to change without notice

F1755G

(PS0806VR)

Free Manuals Download Website

<http://myh66.com>

<http://usermanuals.us>

<http://www.somanuals.com>

<http://www.4manuals.cc>

<http://www.manual-lib.com>

<http://www.404manual.com>

<http://www.luxmanual.com>

<http://aubethermostatmanual.com>

Golf course search by state

<http://golfingnear.com>

Email search by domain

<http://emailbydomain.com>

Auto manuals search

<http://auto.somanuals.com>

TV manuals search

<http://tv.somanuals.com>