

Telecommunication Peripheral Products
Technical Practice

MLC-24
Message Waiting
Lamp Controller
March 2, 1998

Add Message Waiting Lamps for Voice Mail....On any Telephone System!



With Viking's **MLC-24** you can integrate visual message waiting indication with nearly any phone system...even those phone systems which do not support message lamps.

The **MLC-24** is compatible with virtually any voice messaging system with "out call" or "dispatch" feature. It can also be activated manually from a Touch Tone phone. The lamps can be reset by the voice mail system or from the user's telephone.

Commands are sent to the controller via C.O. line or analog PABX/KSU station or trunk port. Up to four **MLC-24** controllers can be connected to a single line.

<http://www.VikingElectronics.com>

[E-mail...Sales@VikingElectronics.com](mailto:Sales@VikingElectronics.com)

Features

- Each MLC-24 controls up to 24 message waiting lamps
- Compatible with 90 to 125V message waiting phones
- Compatible with LED's or Viking **LM-1** or **LM-2** retrofit message waiting lamp kit
- Displays both steady lamp or flash for urgent messages
- Expandable in multiples of 24 lamps
- Uses existing C.O. lines or analog PABX/KSU stations
- Built in diagnostics to aid installer

Made in the U.S.A.

Applications

- Voice mail systems that don't provide message waiting voltage
- Remote voice mail systems
- Staff "In - Out" board
- "Do Not Disturb" lights

Sales...(715) 386 - 8861

Specifications

Power: 120V AC/13.8V AC 1.25A, UL listed, adapter provided
Dimensions: 8.25mm x 160mm x 44mm (8.25" x 6.25" x 1.75")
Shipping Weight: 1.36 kg (3 lbs.)
Environmental: 0°C to 32°C (32°F to 90°F) with 5% to 95% non-condensing humidity
Connections: (1) RJ21X male, (1) RJ21X female, (1) RJ11 com port

Installation

A. Centrex or PABX Installation with Standard Phones

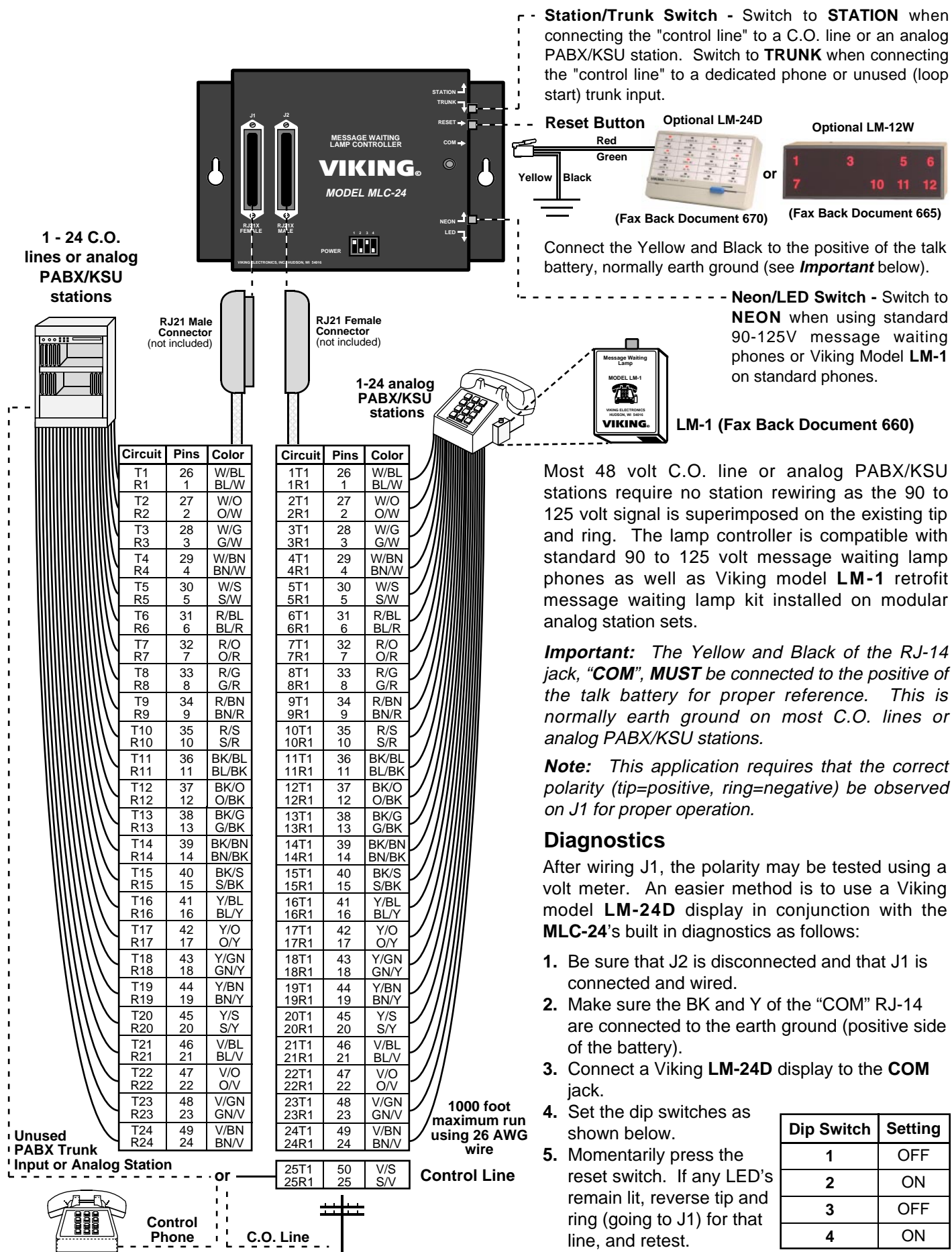

B. Electronic or Digital Phone Installation with LM-2 Message Waiting Lamps

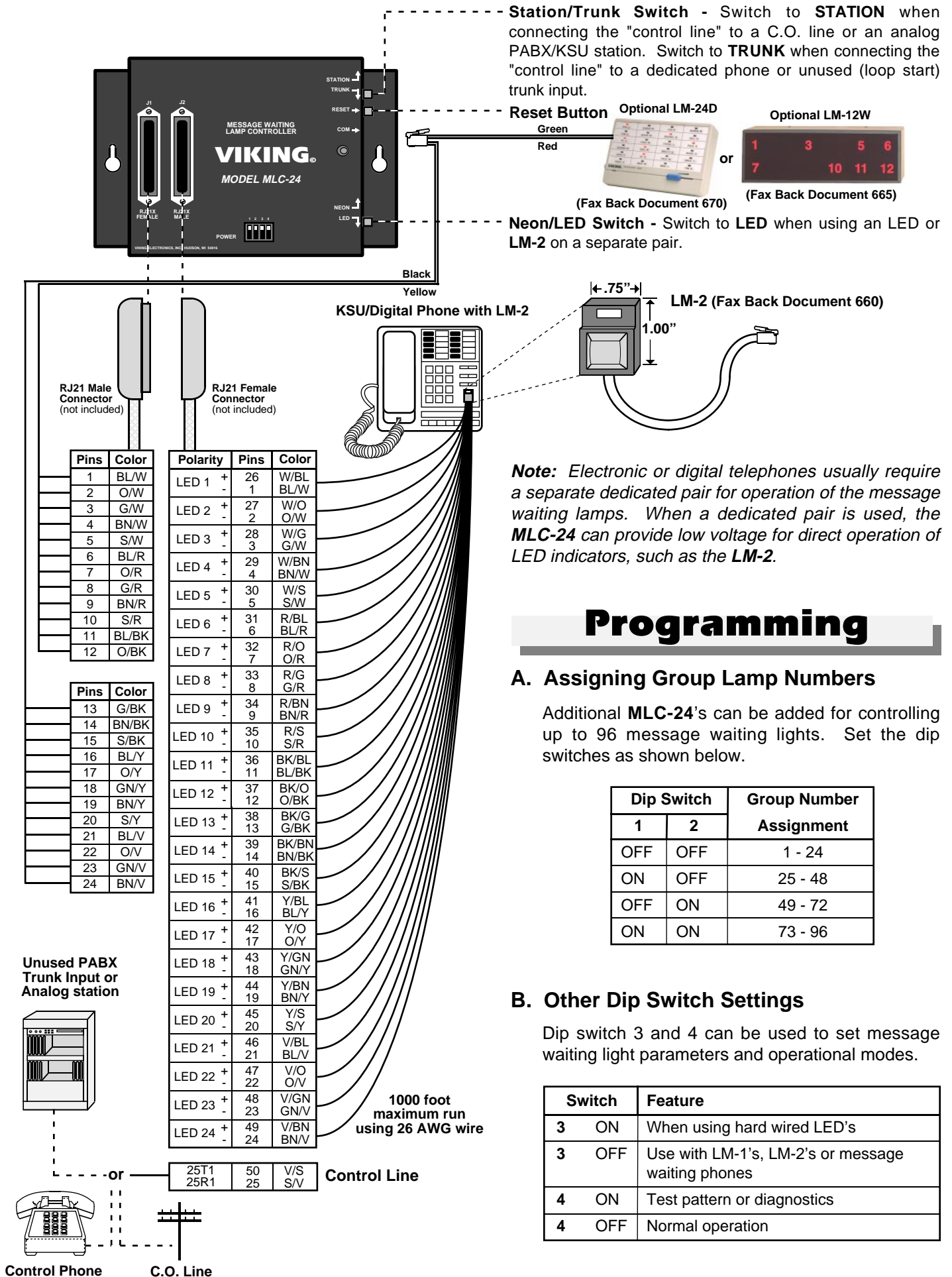

Operation

A control phone connected directly to the **MLC-24**'s "control line" controls the lamps. The "control line" may also be connected to a C.O. line, analog PABX/KSU station, or an unused C.O. port.

One **MLC-24** controller can serve 24 different station lamps, plus up to three 24 line status displays (**LM-24D** or **LM-12W**) for the receptionist(s). Up to four **MLC-24**'s can be installed on a single extension or line.

In voice mail applications the "dispatch" or "out-call" feature is used to call the extension assigned to the **MLC-24**, which answers and provides a 500 Hz tone. The voice mail system then sends a three digit DTMF code that specifies the status of an individual lamp. For example, a Touch Tone code of "1, 24" would cause lamp 24 to be off, a "2, 24" would cause it to be on steady, a "3, 24" would cause it to flash and a "4, 24" would cause it to fast flash. When the three digit code is complete, the **MLC-24** hangs up. The 3 digit code can also be entered manually from any Touch Tone phone.

In applications where a ringing extension is not available, the **MLC-24** can be programmed to provide talk battery for direct connection to an unused trunk input, a standard DTMF phone or the voice mail "dispatch" or "out-call" port, if compatible.

A. On Premise Operation

When the **MLC-24** is connected to a station circuit of a PABX, the voice mail system or user must first dial the station (extension) number connected to the **MLC-24**'s "control line." The **MLC-24** will answer with a steady tone. The command codes can then be entered as shown in the table to the right.

Signaling the MLC-24...	Enter Digits
1. ...to turn lamp OFF at station xy*	1 + xy*
2. ...to turn lamp ON at station xy*	2 + xy*
3. ...to flash a lamp at station xy*	3 + xy*
4. ...to fast flash a lamp at station xy*	4 + xy*
5. ...to turn all lamps OFF	1 - 4 + 99

* xy refers to numbers 1 - 96

B. Off Premise Operation

When the **MLC-24** is located in a remote facility, the voice mail system or user must call the telephone number of the phone line connected to the "control line" of the **MLC-24** (J2 Pins 25, 50). The **MLC-24** will answer with a steady tone. The command codes can then be entered as shown in the table.

C. Message Waiting Lamp Illumination

1. Neon Message Waiting Phones and/or LM-1 Modular Message Waiting Lamp Retrofit Kit

This kit will illuminate when the receiver is on-hook. They will go out when the receiver is off-hook and go on as the receiver is returned on-hook. The lamp may be extinguished by an off Touch Tone code or by momentarily (.25 - 2 seconds) going off hook.

2. LM-2 LED Message Waiting Lamp Kit

This kit will illuminate immediately and remain on until the **LM-2** switch is depressed momentarily (.25 - 2 seconds) or an off Touch Tone code is issued to extinguish the LED.

3. LED's

These will illuminate immediately and remain on until an "off" Touch Tone code is issued to extinguish the LED.

D. Power Failure

In the event of AC power failure, the message waiting lamps will not function. All telco operations will operate as normal.

E. Special Features

1. With switch positions 1 and 3 in the OFF position and 2 and 4 in the ON position, the display will indicate on or off hook condition for 24 lines (off-hook = LED is on, on-hook = LED is off). **Note:** Depress the reset button on the **MLC-24** after changing switch positions.
2. With switch positions 2 and 3 in the "off" position and 1 and 4 in the "on" position, the installer can generate a test pattern that will aid in the installation. The **MLC-24** will turn the lamps on one at a time, then turn them all off. This will continue until the switches are placed back into position for normal operation.

Product Support Line...(715) 386-8666

Fax Back Line...(715) 386-4345

Due to the dynamic nature of the product design, the information contained in this document is subject to change without notice. Viking Electronics, its affiliates and/or subsidiaries assume no responsibility for errors and/or omissions contained in this information. Revisions of this document or new editions of it may be issued to incorporate such changes.

Free Manuals Download Website

<http://myh66.com>

<http://usermanuals.us>

<http://www.somanuals.com>

<http://www.4manuals.cc>

<http://www.manual-lib.com>

<http://www.404manual.com>

<http://www.luxmanual.com>

<http://aubethermostatmanual.com>

Golf course search by state

<http://golfingnear.com>

Email search by domain

<http://emailbydomain.com>

Auto manuals search

<http://auto.somanuals.com>

TV manuals search

<http://tv.somanuals.com>