



TECHNICAL SERVICE MANUAL

MAGNETIC DRIVE PUMPS
 SERIES 823 – STEEL
 825 – CAST IRON
 827 – STAINLESS STEEL
 SIZES K & KK

SECTION	TSM 845
PAGE	1 OF 14
ISSUE	F

CONTENTS

Introduction	1
Safety Information	2
Special Information	3
Maintenance	3
Disassembly: Pump	4
Disassembly: Coupling	6
Disassembly & Assembly of MD-C Series Bearing Housing	8
Installation of Bushings	10
Assembly: Coupling	10
Adjusting Head Gasket End Clearance	11
Pump Rotation	11
Pressure Relief Valve	11
Troubleshooting	13
Warranty	14

Model Number Chart

UNMOUNTED	UNITS
K-823 , 825 , 827	Units are designated by the unmounted pump model numbers followed by a letter(s) indicating drive style.
KK823 , 825 , 827	B = Bracket Mount R = Viking Reducer Drive P = Commercial Speed Reducer (Example: KK-827-MD-C80R)

TABLE 1

This manual deals only with Series 823, 825 and 827 magnetic drive pumps and couplings. Refer to Figures 1 thru 23 for general configuration and nomenclature used in this manual. Pump specifications and recommendations are listed in Catalog Section 845.

WARNING !

Persons with surgical implants of a metallic or electronic nature should avoid working on pump – especially the inner magnet assembly.

INTRODUCTION

The illustrations used in this manual are for identification purposes only and should not be used for ordering parts. Secure a parts list from the factory or a Viking® representative. Always give complete name of part, part number or material with model number and serial number of pump when ordering repair parts. The unmounted pump or pump unit model number and serial number can be found on the nameplate.

In the Viking® model number system, the basic size letters are combined with the series (823, 825, 827), indicating basic pump construction material (steel, cast iron, or stainless steel respectively). See Model Number Chart.



FIGURE 1
 K & KK-827 (stainless steel) MD-C80 B Bearing Carrier, Footed Bracket and Mounted Pump with Flanged Ports.

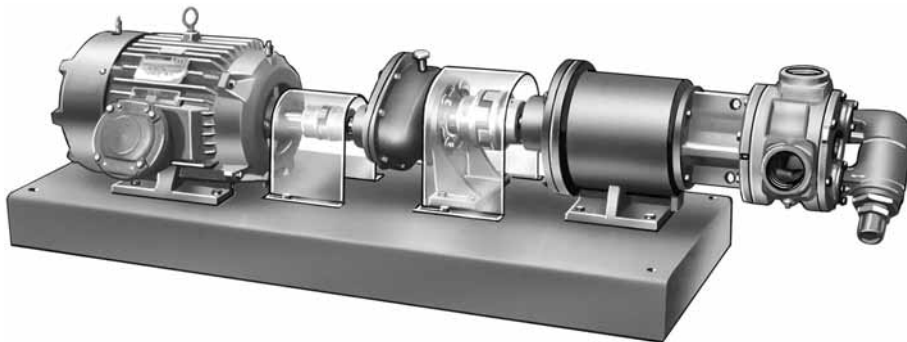

FIGURE 2
 K & KK-825 (cast iron) MD-C80 R Unit complete with Motor, "B" Gear Reducer, Bearing Carrier mounted to base with Mounted Pump featuring Tapped Ports.

SAFETY INFORMATION

INCORRECT INSTALLATION, OPERATION OR MAINTENANCE OF EQUIPMENT MAY CAUSE SEVERE PERSONAL INJURY OR DEATH AND/OR EQUIPMENT DAMAGE AND MAY INVALIDATE THE WARRANTY.

This information must be read fully before beginning installation, operation or maintenance and must be kept with the pump. All installation and maintenance must be undertaken by suitably trained or qualified persons only.

Symbol Legend :



Danger - Failure to follow the listed precautionary measures identified by this symbol may result in serious injury or death.

WARNING

Warning - Safety instructions which shall be considered for reasons of safe operation of the pump or pump unit and/or protection of the pump or pump unit itself are marked by this symbol.

	<p>DO NOT OPERATE PUMP IF:</p> <ul style="list-style-type: none"> - The front cover is not installed correctly. - Any guards are missing or incorrectly installed. - The suction or discharge piping is not connected. 	WARNING	<p>Before operating the pump, be sure that it and all parts of the system to which it is connected are clean and free from debris and that all valves in the suction and discharge pipelines are fully opened. Ensure that all piping connecting to the pump is fully supported and correctly aligned with its relevant connections. Misalignment and/or excess loads will cause severe pump damage.</p>
	<p>DO NOT place fingers, etc. into the pumping chamber or its connection ports or into any part of the drive train if there is ANY possibility of the pump shafts being rotated. Severe injury will occur.</p>		<p>Be sure that pump rotation is correct for the desired direction of flow.</p>
	<p>DO NOT exceed the pumps rated pressure, speed, and temperature, or change the system/duty parameters from those for which the pump was originally supplied, without confirming its suitability for the new duty.</p>	WARNING	<p>DO NOT INSTALL THE PUMP INTO A SYSTEM WHERE IT WILL RUN DRY (I.E. WITHOUT A SUPPLY OF PUMPED MEDIA).</p>
	<p>INSTALLATION AND OPERATION OF THE PUMP MUST ALWAYS COMPLY WITH HEALTH AND SAFETY REGULATIONS.</p>	WARNING	<p>Pressure gauges/sensors are recommended, next to the pump suction and discharge connections to monitor pressures.</p>
	<p>Rare earth magnets used in couplings have extremely strong magnetic fields capable of changing performance or damaging items such as: Pacemakers, Metal Implants, Watches, Computers & Disks, and Credit Cards</p> <p>Completely assembled magnetic couplings will not affect items listed above - only disassembled components.</p> <p>There are no known harmful effects of these magnetic fields on the human body.</p>		<p>Caution must be taken when lifting the pump. Suitable lifting devices should be used as appropriate. Lifting eyes installed on the pump must only be used to lift the pump, not pump with drive and/or baseplate. If pump is baseplate mounted, the base plate must be used for all lifting purposes. If slings are used for lifting, they must be safely and securely attached. For weights of bare shaft pumps refer to catalog.</p>
WARNING	<p>A device must be incorporated into the pump, system, or drive to prevent the pump exceeding its stated duty pressure. It must be suitable for both directions of pump rotation where applicable. Do not allow pump to operate with a closed/blocked discharge unless a pressure relief device is incorporated. If an integral relief valve is incorporated into the pump, do not allow re-circulation through the relief valve for extended periods.</p>		<p>DO NOT attempt any maintenance or disassembly of the pump or pump unit without first ensuring that :</p> <ul style="list-style-type: none"> - The pump is fully isolated from the power source (electric, hydraulic, pneumatic). - The pumping chamber, relief valve and any shaft seal support system are depressurized and purged. - Any temperature control devices (jackets, heat-tracing, etc) are fully isolated, that they are depressurized and purged, and components are allowed to reach a safe handling temperature.
	<p>The mounting of the pump or pump unit should be solid and stable. Pump orientation must be considered in relation to drainage requirements. Once mounted, shaft drive elements must be checked for correct alignment. Rotate pump shaft by at least one full revolution to ensure smoothness of operation. Incorrect alignment will produce excessive loadings and will create high temperatures and increased noise emissions. Do not use any drive arrangements which cause sideloading of the drive shaft.</p>		<p>DO NOT attempt to dismantle a pressure relief valve which has not had the spring pressure relieved or is mounted on a pump that is operating. Serious personal injury or death and/or pump damage may occur.</p>
			<p>DO NOT loosen or undo the front cover, any connections to the pump, shaft seal housings, temperature control devices, or other components, until sure that such action will not allow the unsafe escape of any pressurized media.</p>
	<p>The installation must allow safe routine maintenance and inspection (to check for leakage, monitor pressures, etc) and provide adequate ventilation necessary to prevent overheating.</p>		<p>Pumps and/or drives can produce sound power levels exceeding 85 dB(A) under certain operating conditions. When necessary, personal protection against noise must be taken.</p>
			<p>Avoid any contact with hot parts of pumps and/or drives which may cause injury. Certain operating conditions, temperature control devices (jackets, heat-tracing, etc.), bad installation, or poor maintenance can all promote high temperatures on pumps and/or drives.</p>

SPECIAL INFORMATION

DANGER !

Before opening any Viking pump liquid chamber (pumping chamber, reservoir, etc.) Be sure:

1. That any pressure in the chamber has been completely vented through the suction or discharge lines or other appropriate openings or connections. (See detailed procedure for venting the pumps, pages 4, 5 and 6).
2. That the driving means (motor, turbine, engine, etc.) has been "locked out" or made otherwise non-operational so that it cannot be inadvertently started while work is being done on the pump.
3. That you know what liquid the pump has been handling and the precautions necessary to safely handle the liquid. Obtain a material safety data sheet (MSDS) for the liquid to be sure these precautions are understood.

Failure to follow above listed precautionary measures may result in serious injury or death.

ROTATION: Viking Mag-Drive® pumps are designed to run in the direction indicated on the nameplate only. If rotation must be reversed, see "Pump Rotation" on page 10.

PRESSURE RELIEF VALVES:

1. Relief valves are mounted on the head of K and KK size pumps. Relief Valves are not available on jacketed heads.
2. If a Relief Valve is not furnished on the pump, some means of over protection such as an in-line relief valve should be provided. Do not rely on magnets decoupling for protection from over pressure. This may result in damage to magnets, pump or other equipment.
3. Relief valve adjusting screw cap must always point towards suction side of pump. If pump rotation is reversed, remove pressure relief valve and turn end for end (See "Pump Rotation" on page 10 for additional steps required for proper operation). See Figure 3.
4. Pressure relief valves cannot be used to control pump flow or regulate discharge pressure.

For additional information on pressure relief valves, refer to Technical Service Manual TSM000 and Engineering Service Bulletin ESB-31.

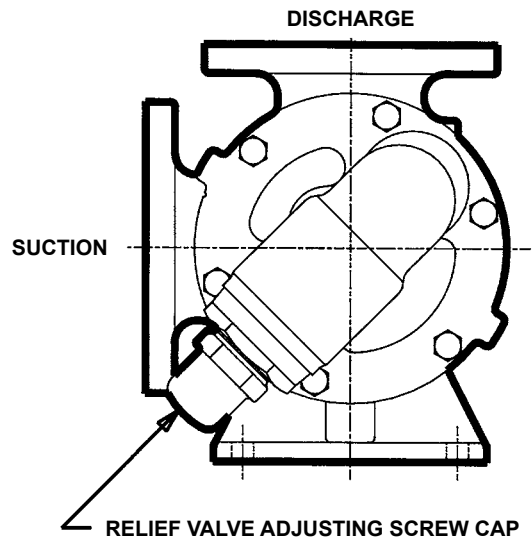

FIGURE 3

MAINTENANCE

CAUTION !

Rare earth magnets used in these couplings have extremely strong magnetic fields capable of changing the performance or damaging items such as the following:

**Pacemakers
Metal Implants
Watches
Computers & discs
Credit Cards**

Completely assembled magnetic couplings will not affect items listed above.

Altered performance or damage can occur only when the coupling halves are separated.

There are no known harmful effects of these magnetic fields on the human body.

Series 823, 825 and 827 pumps are designed for long, trouble-free service life under a wide variety of application conditions with a minimum of maintenance. The points listed below will help provide long service life.

CLEANING PUMP: Keep pump as clean as possible. This will facilitate inspection, adjustment and repair work.

STORAGE: If pump and coupling are to be stored, drain pump and pour non-detergent SAE 30 weight oil into the pump port. Apply grease to the pump or the coupling shaft extension, if present or accessible. Viking suggests rotating pump shaft by hand one complete revolution every 30 days to circulate the oil. The coupling should be stored in a dry area.

Note: if the liquid to be pumped reacts with oil, use an acceptable alternate.

SUGGESTED REPAIR TOOLS: The following tools are required to properly repair Series 823, 825, and 827 pumps. These tools are in addition to standard mechanics' tools such as open-end wrenches, pliers, screwdrivers, etc. Most of the items can be obtained from an industrial supply house.

1. Soft face hammer
2. Allen wrenches
3. External Snap ring pliers - 2-810-029-375
4. Internal Snap ring pliers - 2-810-047-999
5. Feeler gauge set
6. Arbor Press
7. Brass Bar
8. Hand Knobs - 2-790-046-999 (2 Required)
9. Standard 5/16" 12 point socket

DISASSEMBLY: PUMP

1. Refer to Figures 4, 5 & 6 for names of parts.
2. Mark head, casing, and bracket before disassembly to insure proper reassembly. The idler pin, which is offset in the pump head, must be positioned toward and an equal distance from port connections to allow for proper flow of liquid through the pump.
3. Remove the head capscrews.

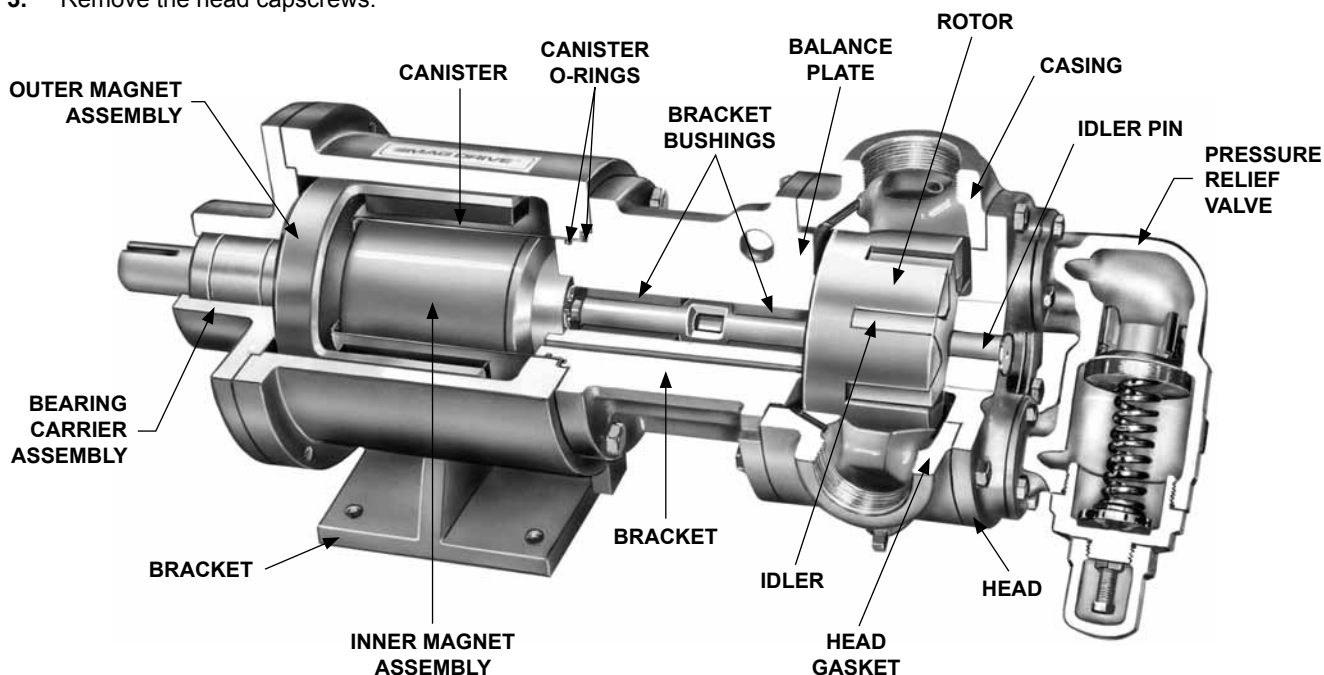

FIGURE 4
CUTAWAY VIEW MAG-DRIVE PUMP, MODEL KK-825 MD-80 B ILLUSTRATED

DANGER !

Before opening any Viking pump liquid chamber (pumping chamber, reservoir, etc.) Be sure:

1. That any pressure in the chamber has been completely vented through the suction or discharge lines or other appropriate openings or connections. (See detailed procedure for venting the pumps, pages 4, 5 and 6).
2. That the driving means (motor, turbine, engine, etc.) has been "locked out" or otherwise made non-operational so that it cannot be inadvertently started while work is being done on the pump.
3. That you know what liquid the pump has been handling and the precautions necessary to safely handle the liquid. Obtain a material safety data sheet (MSDS) for the liquid to be sure these precautions are understood.

Failure to follow above listed precautionary measures may result in serious injury or death.

4. Remove head from pump. Do not allow idler to fall from idler pin. Tilt top of head back when removing to prevent this. Avoid damaging head gasket set, all gaskets are required to maintain end clearance.
 5. Remove idler and bushing assembly. If idler bushing needs replacing, see **“Installation of Bushings” page 9**. If further disassembly is required pump must be separated from coupling. Refer to **“Disassembly: Coupling,” on page 6**, before proceeding with Step 6.
 6. After inner magnet is removed then remove key and external retaining ring from the shaft. Rotor and shaft may now be extracted by tapping on end of the shaft with a soft face hammer (if a soft faced hammer is unavailable a regular hammer may be used with a piece of hardwood).
 7. Mark the location and orientation of the Balance plate before removing by pulling out. (The balance plate may not be removable in the 825 series).
- The casing should be examined for wear, particularly in the area between ports. All parts should be checked for wear before pump is assembled.
- When making major repairs, such as replacing a rotor and shaft, it is advisable to also install a new head and idler pin, idler and bushing, and casing bushings. See **“Installation of Bushings” on page 9**.
- Clean all parts thoroughly and examine for wear or damage. Check bushings, idler pin and balance plate; replace if necessary.

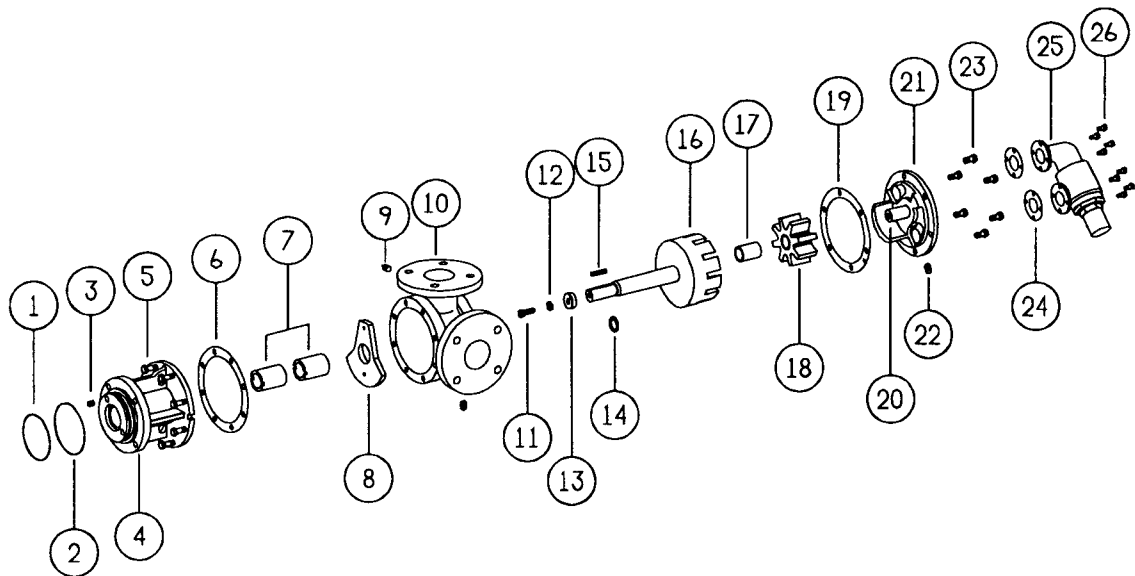

ITEM	NAME OF PART	ITEM	NAME OF PART	ITEM	NAME OF PART
1	Bracket Gasket - Primary	10	Casing	19	Head Gasket
2	Bracket Gasket	11	Capscrew for Inner Magnet	20	Idler Pin
3	Orifice	12	Lockwasher	21	Head & Pin
4	Bracket	13	Washer	22	Pipe Plug
5	Capscrews for Casing	14	External Retaining Ring	23	Capscrews for Head
6	Casing Gasket	15	Key	24	Gaskets for Relief Valve
7	Bracket Bushings	16	Rotor & Shaft	25	Relief Valve
8	Balance Plate (Maybe Not in 825)	17	Idler Bushing	26	Capscrews for Relief Valve
9	Pipe Plugs	18	Idler & Bushing		

**FIGURE 5
K & KK MAG DRIVE PUMP**

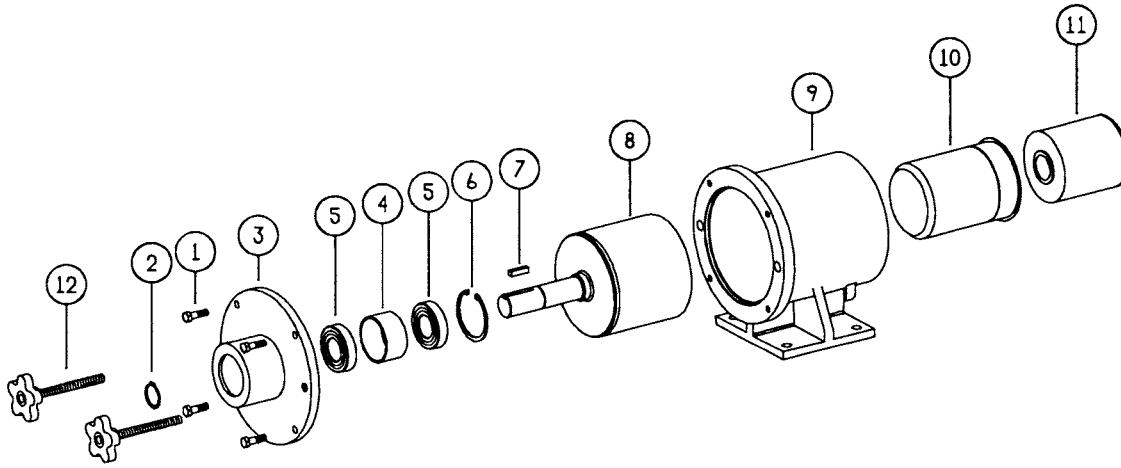

ITEM	NAME OF PART	ITEM	NAME OF PART	ITEM	NAME OF PART
1	Capscrews	5	Ball Bearing (2 Req'd)	9	Bracket
2	External Snap Ring	6	Internal Snap Ring	10	Canister
3	Bearing Housing	7	Key	11	Inner Magnet Assembly
4	Bearing Spacer	8	Outer Mag Assembly	12	Hand Knobs

**FIGURE 6
MD-C SERIES COUPLING**

DISASSEMBLY: COUPLING SERIES MD-C80 COUPLING

1. If unit has a spacer coupling then bracket of coupling can stay bolted to base. Without spacer coupling, either the reducer will need to be removed or the coupling unbolting. Remove piping to pump, provide a minimum of 4" of clearance beyond end of coupling shaft. Insert (2) .5" U.N.C. handknobs which have a minimum of 4.5" of full threads into the two tapped holes at 9 and 3.00 positions on the back of the bearing housing. Remove the (4) .375 capscrews. **See Figure 7.**

CAUTION !

Magnet sets are extremely powerful. Serious injury may result if proper procedures are not followed.

2. Turn the handwheels evenly to back out the bearing housing and outer magnet assembly. **See Figure 8.**

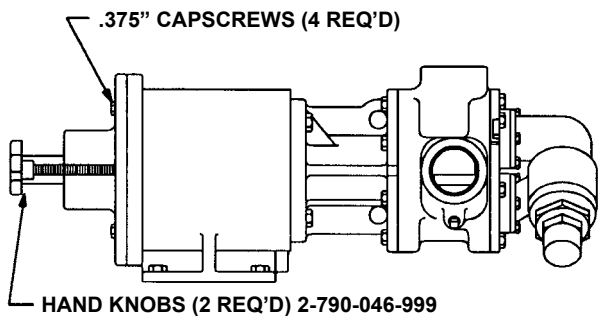

FIGURE 7

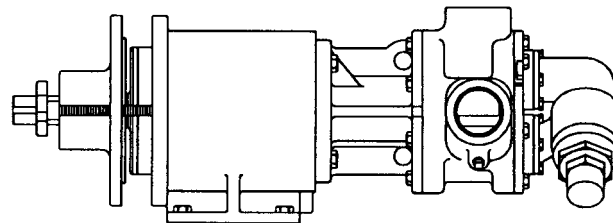

FIGURE 8

CAUTION !

Do not attempt to pull the magnet sets apart by hand until the outer has been backed off 4". Support the outer magnet assembly and pull completely away from the inner magnet. Be careful when setting down this unit to avoid tools and other metal objects being attracted to the end of the magnet.

- Support pump with hoist and remove the (4) .5" capscrows. See Figure 9. Pull the pump out of the bracket; there will be some resistance to pull apart since the inner magnet assembly will be attracted to the coupling bracket. If further disassembly of the bearing carrier is required, refer to page 7. Since there will be some liquid left in the canister, be aware that liquid will run out when the canister separates from the pump. Remove canister if it has not already come off the pump.

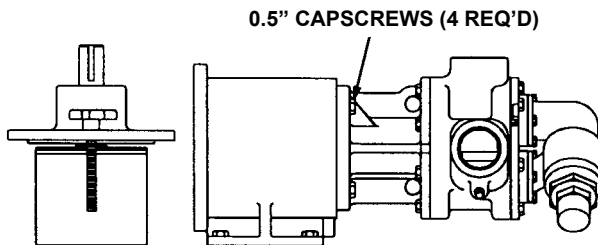

FIGURE 9

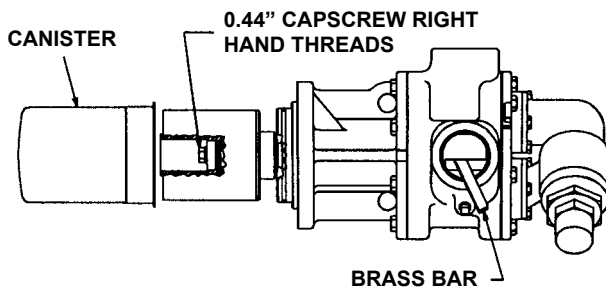

FIGURE 10

- Insert a brass bar through a port between two rotor teeth and loosen the capscrow holding the inner magnet to the shaft (See Figure 11). Do not forget, this is a very strong magnet. If pump disassembly is required, remove the external retaining ring.
- Do not remove the O-ring unless it is bad, especially if PTFE (Derivative) encapsulated. If a new O-ring is required, follow instructions in the "Assembly: Pump" on page 7.

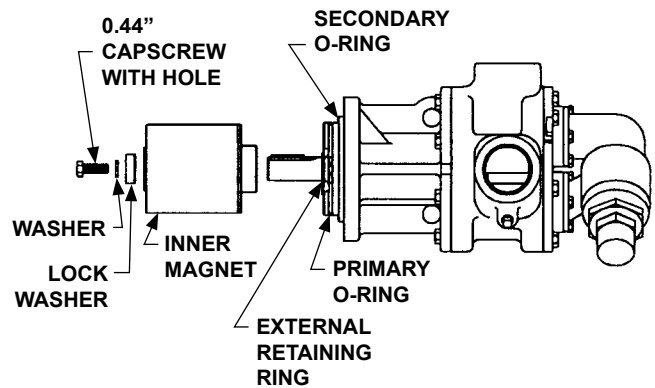

FIGURE 11

DISASSEMBLY & ASSEMBLY OF MD-C SERIES BEARING HOUSING

DISASSEMBLY

The bearing housing features two sealed ball bearings along with an outer magnet assembly. If further disassembly of this unit is required, proceed as follows:

1. Refer to **Figure 12** for part identification. Cover the open end of the outer magnet with a piece sheet metal or cardboard. This will keep foreign material out of magnet area. Set the assembly face down with the shaft pointing up and remove handknobs.
2. Remove external retaining ring from shaft, place unit into press and push out shaft as shown in **Figure 13**. Support end of outer magnet to prevent it from dropping as possibly being damaged.
3. Remove the internal retaining ring and press out bearings.

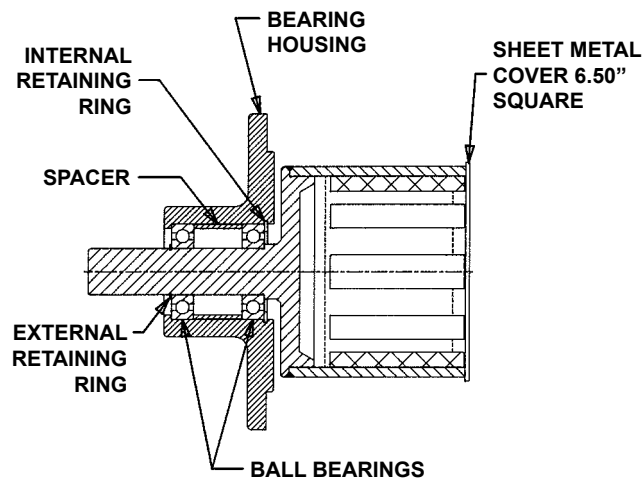

FIGURE 12

ASSEMBLY

1. Place (1) bearing into housing bore. Gently tap or press into bore. Position spacer in bore and insert second bearing. Press down until bearings bottom out. Install internal retaining ring into bearing housing.
2. Slide shaft of outer magnet assembly into bearing until it meets resistance. Set upright in press (**See Figure 14**) and place a spacer on the end of housing such as 3" NPT coupling and press housing down until bearing bottoms out on shaft shoulder. Install external retaining ring on shaft of outer magnet assembly.

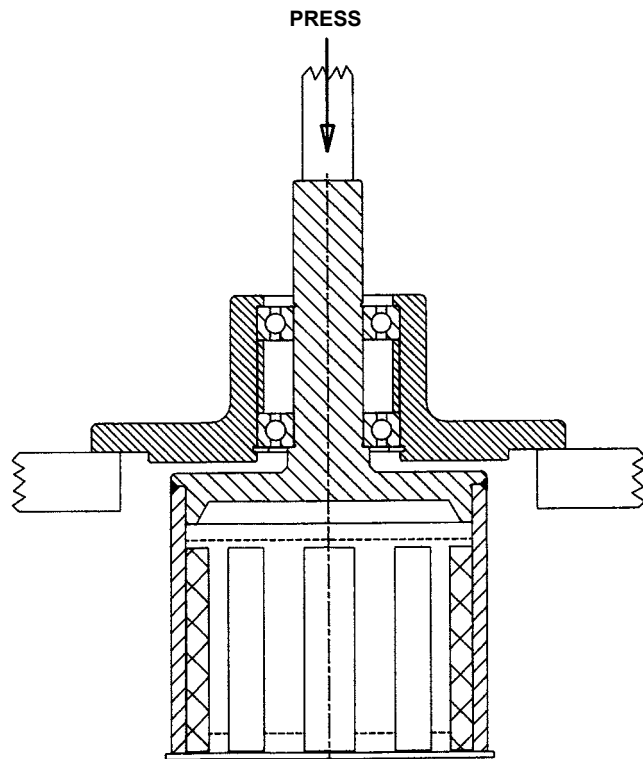

FIGURE 13

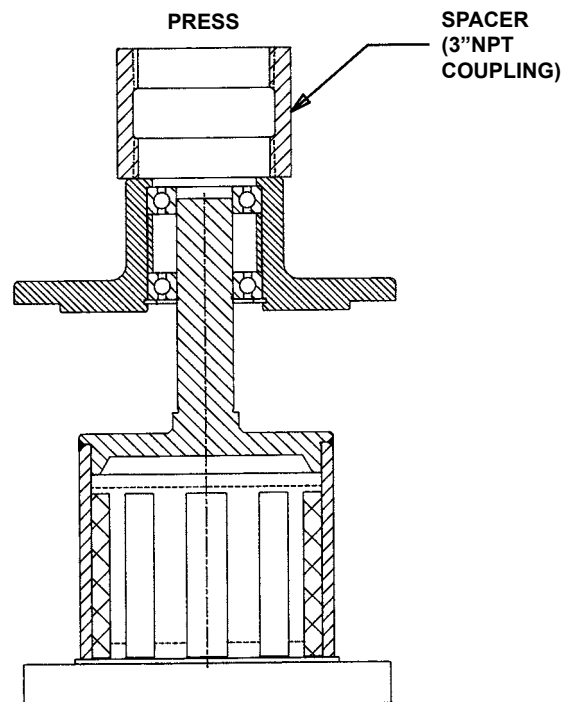

FIGURE 14

ASSEMBLY: PUMP

Use a suitable lubricant compatible with the fluid being handled when reassembling the pump.

Inspect all parts, especially drilled holes in casing for the suck back system to make sure they are not plugged. Replace any worn parts and polish any burrs; clean all parts; assemble pump.

1. If the canister O-rings need to be replaced, apply a lubricant to the O-ring and place into the O-ring groove. If the O-ring is PTFE (derivative) encapsulated, follow these special instructions.

Do not attempt to reuse the primary O-ring if it has been removed (and is PTFE derivative encapsulated). Immerse a new O-ring in boiling water and stretch out O-ring so it will fit onto casing hub without forcing over a sharp edge. Run hot water over O-ring until it shrinks down tight onto the pilot of the pump. Dry with compressed air. The secondary PTFE derivative encapsulated O-ring can be placed in the bracket groove with some lubricant.

2. **If casing was removed from bracket, inspect flat gasket and replace if necessary. Install casing onto bracket pilot in the same orientation as before. This series of pumps does not allow rotating the casing to alternate port configurations – to modify the port arrangement, Refer to “Pump Rotation” on page 10.** Secure the casing with (8) capscrews.
3. Place the balance plate (if separate from bracket) into the casing bore (this step may not be required in the 825 series). Make sure plate is positioned the same as before. **Refer to Figure 15** for standard balance plate positioning.

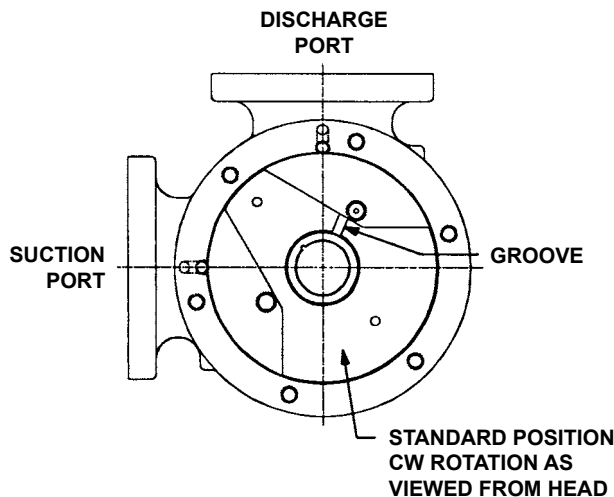

FIGURE 15

4. Clean rotor and shaft so it is free of dirt, grit and other debris and apply lubricant. Push into casing and bracket bushings as far as it will go.

5. If old gaskets are not reusable, refer to “Adjusting Head Gasket End Clearance” on page 10. Otherwise, place the head gaskets on the head. The proper amount of gaskets should be used to provide the correct end clearance. **Table 2** gives the quantity of gaskets available in a gasket set along with standard end clearance.

GASKET TABLE

PUMP MODEL	NORMAL END CLEARANCE (INCH.)	SET OF GASKETS CONSISTS OF THE FOLLOWING
K & KK 825	.008	(1) .015 (2) .007
K & KK 823, 827	.010	(3) .005

End clearances are adequate for viscosity's up to 750 SSU (SAE 20-lube oil at room temperature). Higher viscosity liquids require additional end clearances.

TABLE 2

As a general guideline, for viscosity's between 750 and 7500 SSU (heavier lube oils) double the amount of end clearance indicated, for viscosity's between 7500 and 25,000 SSU (e.g., resins) triple the amount indicated.

For specific recommendations for end clearances for viscosity or for operating temperatures above 225°F, check with your Viking Representative or consult the factory.

6. Coat the idler pin with a suitable lubricant and place the idler on the idler pin in the head.
7. The head can now be assembled on the pump. Tilt the top of the pump head away from the pump slightly until the crescent enters the inside diameter of the rotor and rotate the idler until its teeth mesh with the rotor teeth. Pump head and casing should have been marked before disassembly to insure proper reassembly. If not, be sure idler pin, which is offset in the pump head, is positioned toward and an equal distance from port connections to allow for proper flow of liquid through the pump.
8. Install relief valve if provided and removed. Valve cap should point to Suction side of the pump (**See Figure 3 on page 2**).
9. Place key and external retaining ring onto shaft then follow instruction listed for assembling to the coupling.

INSTALLATION OF BUSHINGS

CARBON GRAPHITE:

When installing carbon graphite bushings, extreme care must be taken to prevent breaking. Carbon graphite is a brittle material and easily cracked. If cracked, the bushing will quickly disintegrate. Using a lubricant and adding a chamfer on the bushing and the mating part will help in installation. The additional precautions listed below must be followed for proper installation:

When removing old bracket bushings, mark location of lubrication groove.

1. An arbor press must be used for installation.
2. Be certain bushing is started straight.
3. Do not stop pressing operation until bushing is in proper position, starting and stopping will result in a cracked bushing.
4. Check bushing for cracks after installation.

SILICON CARBIDE

When installing Silicon Carbide bushings into a metal part the mating part must be heated to 600° F (preferable in an oven). The bushing must be put into the proper position quickly before the mating part cools down and the bushing heats up. Failure to follow this procedure will result in cracked bushings.

ASSEMBLY COUPLING:

SERIES MD-C80 COUPLING

DANGER !

Follow these directions exactly to avoid injury to self or damage to pumping unit. Be careful to keep inner & outer magnets at least (1) foot apart until step 3. Do not engage magnets in any other fashion.

1. Inspect magnets for any steel objects attached to the magnets. Remove any foreign material. Place external retaining ring and key on pump shaft. Slide inner magnet assembly onto shaft so it butts against retaining ring. Install washer, lock washer and capscrew to secure magnet (See Figure 16). Insert a brass bar through a port between two rotor teeth and tighten capscrew.

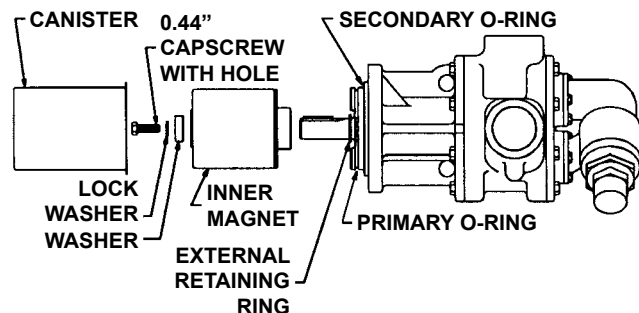

FIGURE 16

2. Inspect canister O-ring for signs of wear and replace if necessary. Slide canister over inner magnet and press over O-ring until canister meets the pump mounting flange.
3. Support the pump from overhead and secure coupling bracket to avoid tipping when pump is attached. Using the canister as a guide, slide the pump assembly up to the coupling bracket through the smaller opening. Secure with the four 0.5\" data-bbox="465 41 870 170"/>

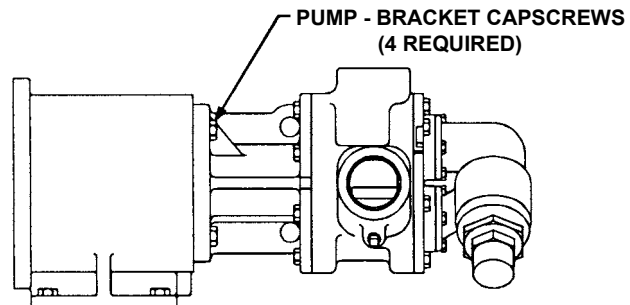

FIGURE 17

4. The outer magnet should be installed into the bearing housing, if not refer to Disassembly & Assembly of Bearing Housing. Install hand knobs so that 4\" data-bbox="465 395 870 516"/>

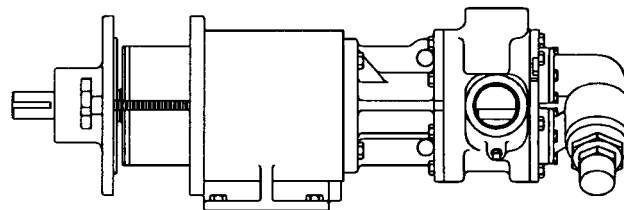

FIGURE 18

5. Install the (4) 0.375\" data-bbox="465 687 870 729"/>

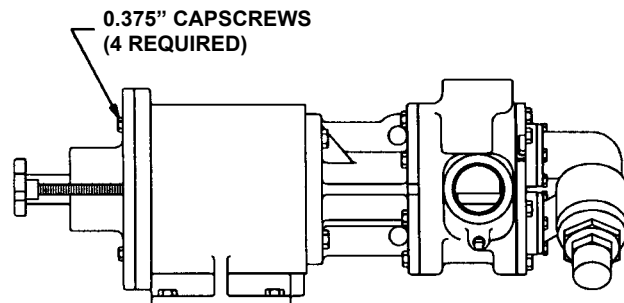

FIGURE 19

ADJUSTING HEAD GASKET END CLEARANCE

Use either of the following procedures to properly adjust the end clearance when replacing gaskets:

PROCEDURE A:

With balance plate in position, slide rotor and shaft into casing. Insert a feeler gage of the proper thickness into the port and between two rotor teeth (See Figure 20 on page 10). Install one 0.015" and one 0.007" gasket onto head. With the idler on the idler pin, place the head into the pump casing. With the capscrews tight, the feeler gage should fit snugly, otherwise gaskets should be added or removed until the proper clearance is attained.

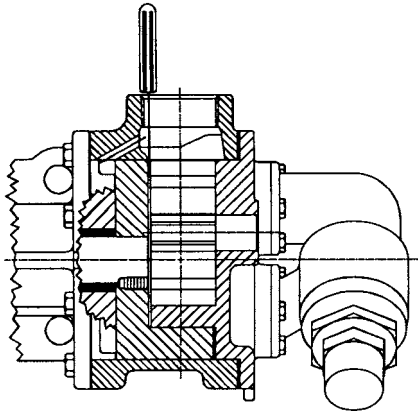

FIGURE 20

PROCEDURE B:

If the pump is in line and the ports are not accessible, remove the head and gaskets. Put the head back on (without gaskets) and measure the gap as shown. (See Figure 21 on page 10). After determining the gap between the head and casing, select a combination of gaskets with approximately 25% more total thickness than the gap plus the required end clearance. Note that the gaskets will compress when head is tightened down. Remove the head, install all gaskets then replace the head. Tighten the head capscrews and check the pump clearance by making sure the pump turns freely by hand.

Since the pump shaft is concealed, it is best to work up the proper end clearance because it is difficult to determine when there is too much end clearance with this approach.

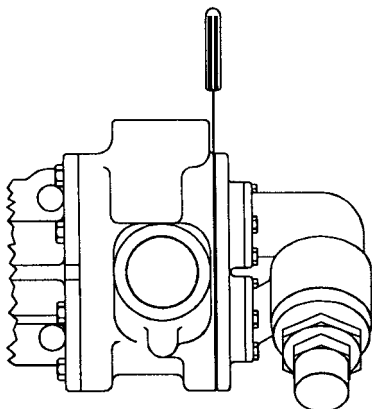

FIGURE 21

PUMP ROTATION

The pump is designed to take fluid from the discharge side of the pump and channel it down the idler pin into the shaft and out into the canister through the capscrew which secures the inner magnet. The fluid is returned through a hole in the casing back to the suction side of the pump. There are generally three parts which may need replacing or adjusting to change rotation.

HEAD & PIN – Hole should be from the discharge side of head to the pin and a pipe plug is placed in the tapped hole on the suction side of the head. To change rotation, move the plug to the opposite side of the head.

BALANCE PLATE – If the plate is separate from the bracket and looks like the Style A in Figure 22, it can be reversed. The groove should connect the discharge port to the bushing bore. If rotation is changed, the plate is flipped over (not rotated) and the groove would not be visible but will still function properly. If the plate is like Style B, it is **NOT** reversible and a new plate will be required.

BRACKET – The bracket will have two holes drilled through and tapped on one side. The discharge side of the bracket should feature a pipe plug with a hole drilled through it. To change rotation simply move this pipe plug to the other hole.

Contact your local Viking distributor or the factory to determine which parts are required.

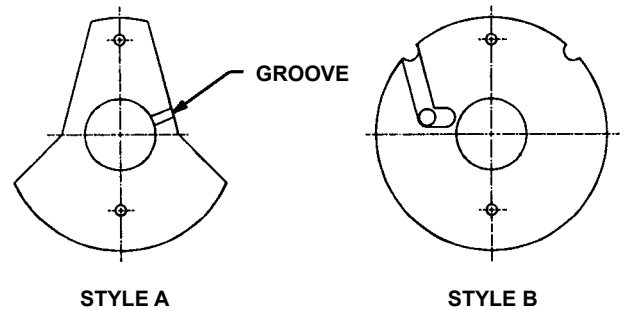

FIGURE 22

PRESSURE RELIEF VALVE

DANGER !

Before opening any Viking pump liquid chamber (pumping chamber, reservoir, etc.) Be sure:

1. That any pressure in the chamber has been completely vented through the suction or discharge lines or other appropriate openings or connections. (See detailed procedure for venting the pumps, pages 4, 5 and 6).
2. That the driving means (motor, turbine, engine, etc.) has been "locked out" or made otherwise non-operational so that it cannot be inadvertently started while work is being done on the pump.
3. That you know what liquid the pump has been handling and the precautions necessary to safely handle the liquid. Obtain a material safety data sheet (MSDS) for the liquid to be sure these precautions are understood.

Failure to follow above listed precautionary measures may result in serious injury or death.

DISASSEMBLY: RELIEF VALVE

Mark valve and head before disassembly to insure proper reassembly.

1. Remove valve cap.
2. Measure and record length of extension of adjusting screw. Refer to "A" on Figure 23.
3. Loosen locknut and back out adjusting screw until spring pressure is released.
4. Remove bonnet, spring guide, spring and poppet from valve body. Clean and inspect all parts for wear or damage and replace as necessary.

DANGER !

Before starting pump, be sure all drive equipment guards are in place.

Failure to properly mount guards may result in serious injury or death.

ASSEMBLY: RELIEF VALVE

Reverse procedures outlined under Disassembly. If valve is removed for repairs, be sure to replace in same position. Relief valve adjusting screw cap must always point towards suction side of pump. If pump rotation is reversed, remove relief valve and turn end for end. Refer to Figure 3, page 2.

PRESSURE ADJUSTMENT

If a new spring is installed or if pressure setting of pressure relief valve is to be changed from that which the factory has set, the following instructions must be carefully followed.

1. Carefully remove valve cap, which covers adjusting screw.
Loosen locknut, which locks adjusting screw so pressure setting will not change during operation of pump.
2. Install a pressure gauge in discharge line for actual adjustment operation.
3. Turn adjusting screw in to increase pressure and out to decrease pressure.
4. With discharge line closed at a point beyond pressure gauge, gauge will show maximum pressure valve will allow while pump is in operation.

IMPORTANT

In ordering parts for pressure relief valve, always give model number and serial number of pump as it appears on nameplate and name of part wanted. When ordering springs, be sure to give pressure setting desired.

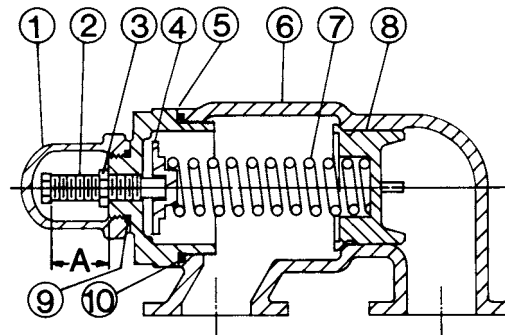

VALVE - AS, AK AND AL SIZES

VALVE - LIST OF PARTS

- | | |
|--------------------|-------------------|
| 1. Valve Cap | 6. Valve Body |
| 2. Adjusting Screw | 7. Valve Spring |
| 3. Lock Nut | 8. Poppet |
| 4. Spring Guide | 9. Cap Gasket |
| 5. Bonnet | 10. Bonnet Gasket |

FIGURE 23

TROUBLESHOOTING

Some of the following may help pinpoint the problem:

Pump does not pump:

- ▶ Lost its prime from air lead or low level in tank.
- ▶ Suction lift too high.
- ▶ Rotating in wrong direction.
- ▶ Strainer clogged.
- ▶ Bypass valve open, pressure relief valve set too low or pressure relief valve poppet stuck open.
- ▶ Improper end clearance.
- ▶ Pump worn out.
- ▶ Any changes in liquid, system or operation that would influence pump or coupling performance, e.g. new liquid, additional lines or process changes.
- ▶ Temperature changes either in the liquid or the environment.
- ▶ Magnetic coupling is decoupling. Change in application (temperature, pressure, viscosity, etc.) may require torque beyond coupling capabilities.

Pump starts, then loses its prime:

- ▶ Supply tank empty.
- ▶ Liquid vaporizing in the suction line.
- ▶ Air leak or air pocket in the suction line.

Pump is noisy:

- ▶ Pump is being starved (heavy liquid cannot get to pump fast enough). Increase suction pipe size, reduce length or slow down pump.
- ▶ Pump is cavitating (liquid vaporizing in suction line). Increase suction pipe size or reduce length.
- ▶ Check alignment.
- ▶ Magnetic coupling decoupled. Shut off and restart.

Pump not delivering up to capacity:

- ▶ Starving or cavitating - increase suction pipe size or reduce length.
- ▶ Strainer partially clogged.
- ▶ Air leak somewhere in suction line.
- ▶ Running too slow. Is motor the correct speed and wired up correctly.
- ▶ Pressure relief valve set too low, tuck open or has damaged poppet / seat.
- ▶ Bypass line around pump partially open.
- ▶ Pump worn out or too many gaskets.

Pump takes too much power (stalls motor):

- ▶ Liquid more viscous than unit sized to handle.
- ▶ System pressure relief valve set too high.
- ▶ Coupling misaligned.
- ▶ Bushings frozen up or liquid set up in coupling.

PUMP INFORMATION

Pump Model Number:

Serial Number:

Date Received:

Date Installed:

Distributor:

Contact Person:

Phone:

Fax:

E-mail:

Comments:

CAUTION !

TO REDUCE THE RISK OF LEAKAGE WITH VIKING MAG DRIVE PUMPS, USERS SHOULD COMPLY WITH THE FOLLOWING GUIDELINES AND ADHERE TO THE FOLLOWING PROCEDURES:

- The pump configuration and materials used in a pump are tailored to the application for which it is ordered. Users should never use a pump for an application that is different from the application specified when the pump was ordered. This includes differences in liquid, speed, pressure, temperature or viscosity.
- Users must understand the characteristics of liquids they are pumping and be especially aware of any particulates in the liquid. Particulates can cause rapid wear of the bushings, especially if carbon graphite bushings are used. Hard bushings and hard shafts can reduce the risk of rapid wear, but the use of hard materials is not always the optimal solution. In applications involving non-abrasive, non-self lubricating liquids, carbon graphite bushings are typically the preferred material.
- Users should periodically inspect their pump for wear. This is especially critical and should be carried out with greater frequency when carbon graphite bushings are used or the same pump has not previously been used for the same application, including the same liquid, speed, pressure, temperature and viscosity. Users should promptly replace worn parts when they are discovered.
- Users should continuously monitor pumps that are handling hazardous liquids. This is especially critical for unmanned, remote locations. If a user does not have in-house expertise in the area of monitoring, it should contact a local engineering firm with monitoring experience.

WARRANTY

Viking warrants all products manufactured by it to be free from defects in workmanship or material for a period of one (1) year from date of startup, provided that in no event shall this warranty extend more than eighteen (18) months from the date of shipment from Viking. The warranty period for Universal Seal series pumps ONLY (Universal Seal models listed below) is three (3) years from date of startup, provided that in no event shall this warranty extend more than forty-two (42) months from the date of shipment from Viking.

UNDER NO CIRCUMSTANCES SHALL VIKING BE LIABLE UNDER THIS WARRANTY OR OTHERWISE FOR SPECIAL, INCIDENTAL, INDIRECT, CONSEQUENTIAL OR PUNITIVE DAMAGES OF ANY KIND, INCLUDING, BUT NOT LIMITED TO, LOST OR UNREALIZED SALES, REVENUES, PROFITS, INCOME, COST SAVINGS OR BUSINESS, LOST OR UNREALIZED CONTRACTS, LOSS OF GOODWILL, DAMAGE TO REPUTATION, LOSS OF PROPERTY, LOSS OF INFORMATION OR DATA, LOSS OF PRODUCTION, DOWNTIME, OR INCREASED COSTS, IN CONNECTION WITH ANY PRODUCT, EVEN IF VIKING HAS BEEN ADVISED OR PLACED ON NOTICE OF THE POSSIBILITY OF SUCH DAMAGES AND NOTWITHSTANDING THE FAILURE OF ANY ESSENTIAL PURPOSE OF ANY PRODUCT.

THIS WARRANTY IS AND SHALL BE VIKING'S SOLE AND EXCLUSIVE WARRANTY AND SHALL BE IN LIEU OF ALL OTHER WARRANTIES, EXPRESS OR IMPLIED, INCLUDING, BUT NOT LIMITED TO, ALL WARRANTIES OF MERCHANTABILITY, FITNESS FOR A PARTICULAR PURPOSE AND NON-INFRINGEMENT ALL OF WHICH OTHER WARRANTIES ARE EXPRESSLY EXCLUDED.

See complete warranty at www.vikingpump.com.

Free Manuals Download Website

<http://myh66.com>

<http://usermanuals.us>

<http://www.somanuals.com>

<http://www.4manuals.cc>

<http://www.manual-lib.com>

<http://www.404manual.com>

<http://www.luxmanual.com>

<http://aubethermostatmanual.com>

Golf course search by state

<http://golfingnear.com>

Email search by domain

<http://emailbydomain.com>

Auto manuals search

<http://auto.somanuals.com>

TV manuals search

<http://tv.somanuals.com>