



# OWNERS MANUAL





## Your Vinotemp

Thank you for your order. Your wine cellar is now under construction. We are sending you this literature in advance to acquaint you with your new wine cabinet. While we at Vinotemp take great care in the preparation and production of your wine cellar, the delivery company and the client play a big part in a successful, happy customer.

You are receiving this owner's manual in advance, in order to help you become familiar with the process of receiving, installing and operating your new wine cabinet.

Our goal at Vinotemp is to produce the finest quality cabinets in the industry. Each of us here at Vinotemp plays a role in the development of your wine cellar. Your unit has been made for you based on the information we've received. We hope you enjoy your wine cabinet for many years to come.

We thank you for your business. We hope that your experience with us is pleasurable and that we have helped you enjoy one of the greatest pleasures in life, collecting and drinking wine.

Sincerely yours,

Alvin Patrick  
Vice President  
Vinotemp International  
17621 S. Susana Rd.  
Rancho Dominguez, California 90221

**Thank you for choosing a Vinotemp wine cellar.**

Please enter the complete model and serial numbers in the space provided.

Model \_\_\_\_\_

Serial Number \_\_\_\_\_

You should also attach your purchase receipt to this manual.



## TABLE OF CONTENTS

<b>Important Safety Information.....</b>	<b>Page 1</b>
<b>Receipt and Inspection of Your Cabinet.....</b>	<b>Page 2</b>
<b>Proper Placement of Your New Cabinet.....</b>	<b>Page 3</b>
<b>Cabinet Alignment and Feature Description.....</b>	<b>Page 4</b>
<b>Digital Controller Operating Instructions.....</b>	<b>Page 5</b>
<b>Bottle Loading / Temperature Control.....</b>	<b>Page 6</b>
<b>Maintenance.....</b>	<b>Page 7</b>
<b>Troubleshooting Guide.....</b>	<b>Page 8</b>
<b>Cellar Disassembly/Reassembly.....</b>	<b>Page 9</b>
<b>WineMate Installation.....</b>	<b>Page 10</b>
<b>Frequently Asked Questions.....</b>	<b>Page 11</b>
<b>More FAQ's.....</b>	<b>Page 12</b>
<b>Terms and Conditions of Sale.....</b>	<b>Back Cover</b>



# Important Safety Information

## **WARNING**



### To avoid the risk of electrical shock, property damage, personal injury or death:

- The power cord must be plugged into a 3-prong grounding-type wall receptacle, grounded in accordance with the National Electrical Code, ANSI/NFPA 70 - latest edition and local codes and ordinances.
- It is the personal responsibility of the consumer to have a proper 3-prong wall receptacle installed by a qualified electrician.
- **DO NOT, UNDER ANY CIRCUMSTANCES, REMOVE THE POWER CORD GROUNDING PRONG.**
- A separate adequately fused and grounded circuit should be available for this appliance.
- Do not remove any grounding wires from individual components while servicing, unless the component is to be removed and replaced. *It is extremely important to replace all grounding wires when components are replaced.*

GROUNDING TYPE  
WALL RECEPTACLE

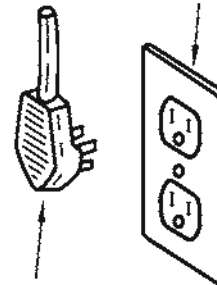

POWER SUPPLY CORD  
WITH 3-PRONG  
GROUNDING PLUG

## **WARNING**



### ELECTRIC SHOCK HAZARD

- Disconnect electric supply from appliance before servicing.
- Replace all panels before operating.
- Failure to do so could result in death or electrical shock

- **DO NOT PLUG IN THE CELLAR UNTIL 24 HOURS AFTER DELIVERY. (TO ALLOW COOLANT TO SETTLE)**
- **DO NOT USE A GROUND FAULT INTERRUPTER (GFI).**
- **A DEDICATED 15 AMP CIRCUIT IS HIGHLY RECOMMENDED.**
- **KEEP CHILDREN FROM ENTERING THE WINE CELLAR.**

## Receipt of your cabinet

Your unit has been shipped from our factory through a moving company that we have used for many years. They have the experience in handling quality furniture products, which are heavy and require specific instructions for the installers to follow. Their instructions include the following:

1. Inspecting the unit.
2. Unpacking the unit and cleaning up the debris
3. Placing the unit in your home in a properly ventilated location.  
(The chart on page 11 shows the necessary clearance for each type of exhaust).
4. adjusting the doors.



*note:* Wait 24 hours before plugging in your unit. Every Vinotemp unit is inspected for quality before careful packaging and shipment from the factory to you.

## Inspection of the Cabinet

When the moving company arrives to install the unit, take a few moments to inspect this packaging before it is removed.

If there is any tearing or other damage to the shipping carton take note of it and inspect those areas of the cabinet thoroughly. Make sure you inspect the unpackaged unit as soon as it is received to insure its condition. This can affect your future warranty. You have within 5 days to report a claim.

Look for any marks, which may affect the potential area of damage.

Any damage must be noted by yourself and the installation crew on the shipping receipt, which you and they will be required to sign.

This notation will assure that damage claims may be filed with the moving company for damage in transit.



## Location of your Wine Cabinet

Designating the proper location for your unit is important. There are several considerations which need to be made in order to receive the best performance results from your unit. They are:

1. Weight Factor
2. Ambient Temperature
3. Proper Ventilation
4. Noise Factor
5. Humidity Control

On the next page we will explore these factors in more detail.



## Weight factor

You will need to take into account that the weight of the unit fully loaded with wine can be substantial. This chart specifies the approximate weights of the units empty and filled with wine.

Model	Unit Weight	Max Bottle Capacity	# of Bottles X 3 lbs (each)	Total Weight
700	550	440	1320	1870 lbs
440	350	280	840	1190 lbs
296	300	224	672	972 lbs
250	275	160	480	755 lbs
230	350	160	480	830 lbs
100	195	80	240	435 lbs

## Ambient temperature factor

The cooling system in the cabinet has the ability to cool a maximum of 25°F below the ambient temperature in the room. Therefore you want to place the unit in a room which will not exceed 78°F. Otherwise the unit will not have the capacity to keep the wine at a desirable 55°F.

On the other hand, you want to make sure the temperature in the room does not fall much below 55°F. The unit only has the capacity to cool the wine inside and cannot exceed the ambient temperature of the room. In addition, the unit is designed only to cool to a minimum temperature of 50°F.

Please note, select models using a more powerful cooling system than the standard 1500 BTU unit and utilizing thicker insulation may be suitable for use in areas with an ambient temperature up to 95°F. Models with glass doors should not be put in extreme environments even when using upgraded cooling and insulation.

## Ventilation factor

Ventilation is an important factor to consider when choosing the correct location. The compressor motor will give off heat, which will need to dissipate away from the unit. If the unit is located within a restricted area and ventilation is not available, then the ambient temperature of the room will increase and thus will prevent the unit from cooling adequately.

Be sure to find a location with good ventilation. For standard (rear exhaust) units, the rear of the unit should be placed 6 inches away from the back wall. In addition, there should be 12 inches of clearance above the top of the unit and 12 inches on each side. This will assure adequate ventilation of the heat exhaust. (Periodically vacuum the grill of the cooling unit to keep dust from clogging the unit).

## Noise factor

These units are motor driven and do produce a nominal amount of noise while the compressor and temperature equalizer fans are in operation. The noise is comparable to the noise of a refrigerator when it is running.

The unit will run continuously during the initial cool down period when the wine bottles are first placed inside the cabinet. After that, the unit will run as needed in order to maintain relative humidity and precise temperature tolerances. The amount of time the unit will need to run is based on the ambient temperature of the room. Front venting cabinets and the Wine Mate 2500 upgraded cooling system are louder due to design and size of compressor.

If the unit is placed on a hard surface such as tile or hardwood floors, it is recommended that you consider installing a small piece of carpeting underneath the unit to prevent the unit's operating noise from echoing against the hard surface.

## Humidity control

The cabinets are designed to maintain humidity. This is accomplished through the design/engineering of the cooling unit. There are no special controls for this function. As the cabinet begins to cool, the humidity in the cabinet will begin to rise, creating the ideal environment for aging wine.

*Note:* The unit does not create humidity. If you live in a dry climate, you can add to the humidity of the cabinet by placing a sponge in a small container of water at the bottom of the cabinet. This will help to create the necessary humidity needed.

## Aligning the unit

Vinotemp wine cabinets are equipped with legs which can be adjusted up or down with a wrench as needed to align the unit. There are two primary reasons for alignment. The first is to assure that the unit stands solidly on the floor without rocking back and forth. The second is to adjust the doors, to assure that they are flush and provide a tight seal.

Alignment should only be done once the cabinet is in its permanent location and prior to filling it with wine. To align the unit, slowly adjust the legs using a wrench. Work in a clockwise motion, making minor adjustments. It may require you to make several complete rotations around the unit in order to complete the needed adjustments.

Do not attempt to level cellar with a leveling device. Proper alignment requires only that the doors are flush and sealing properly and that all of the legs of the unit are touching the ground. If the doors are not properly sealed it will allow cool air to escape and your cabinet will not perform to its best ability.

Note: Adjustment of the legs for proper alignment is the customer's responsibility.



Poorly Aligned

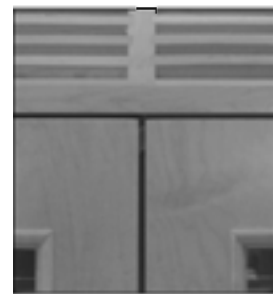

Properly Aligned

## Feature Description

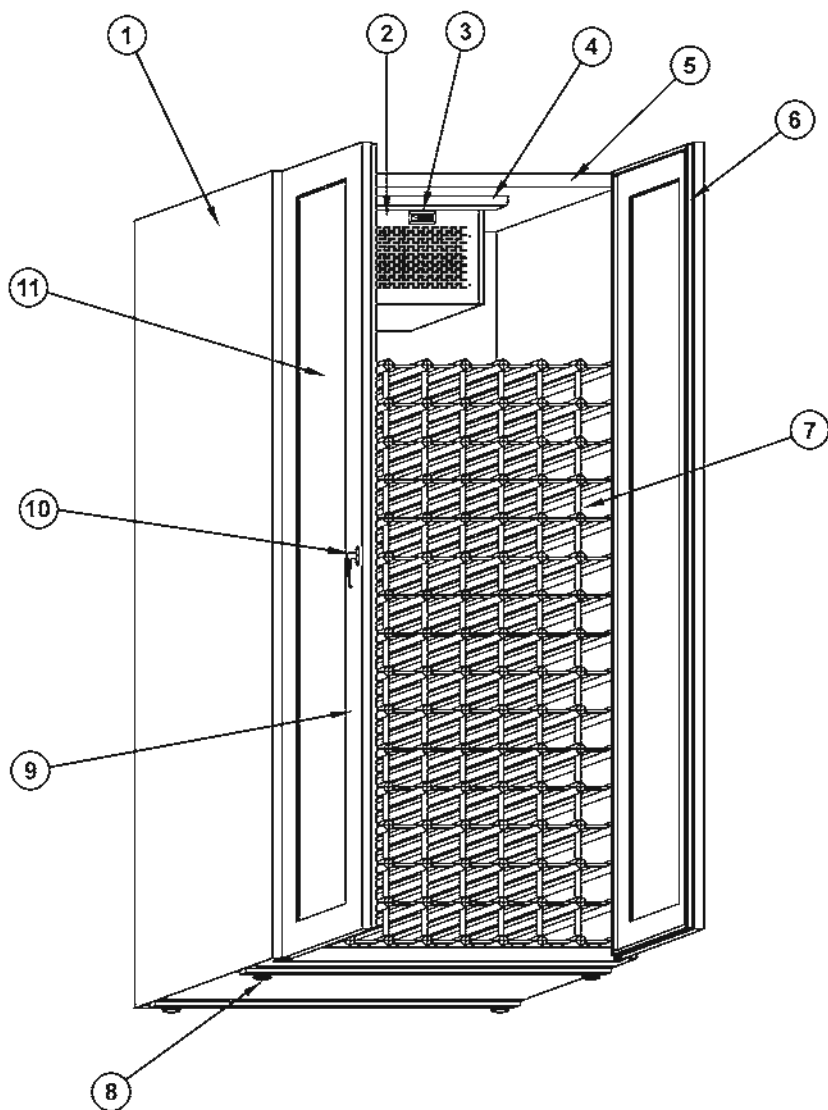

1. Cabinet
2. Cooling Unit
3. Digital Controller
4. Light
5. Magnetic SS Strip
6. Heavy Duty Gasket
7. Rack
8. Adjustable Foot
9. Hinged Door(s)
10. Handle and Lock
11. Dual Paned Glass

### Features:

The Vinotemp wood wine cellar is designed and used to provide a stable temperature between 52-62 °F in a normal environment.





The cellar will keep a desired humidity of 50-70% even when the environment fluctuates between dry and humid air.

These temperatures and humidity levels are optimized for long term wine storage.

Top, front, rear and side exhaust options are available for convenient installations.

# Wine Mate Digital Controller

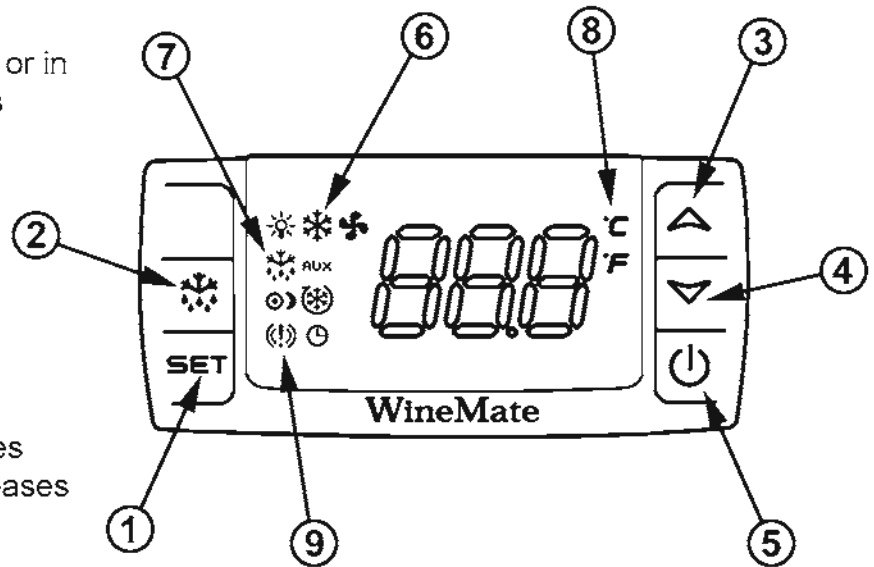

## Front Panel Controls

- 1 **SET** Displays the target set point, or in programming mode it selects a parameter or confirms an operation.
- 2  (DEF) Starts a manual Defrost.
- 3  (UP) Displays the maximum recorded temperature, or in programming mode it browses the parameter codes or increases the displayed value.
- 4  (Down) Displays the minimum recorded temperature, or in programming mode it browses the parameter codes or decreases the displayed value
- 5  (Power) Turns on/off the controller



*Note: During normal working conditions, the display shows the temperature measured in the air, in case of an active alarm, the display flashes between the temperature and the alarm code.*

## LED Indicators

- 6  When this LED is on it indicates that the compressor is enabled, when it is flashing it means that the Anti-short Cycle Delay has been enabled.
- 7  This LED goes on during defrost mode.
- 8 **°C °F** The °C or °F indicates the temperature measuring unit (Celsius or Fahrenheit). A flashing °C or °F means that the unit is in programming mode.
- 9  This LED indicates that an alarm is occurring. The alarm codes are listed below:

### Alarm Codes:

P1 = Room probe failure (compressor output acc. to par. "Con" and "COF")  
HA = Maximum temperature alarm (Outputs unchanged)  
LA = Minimum temperature alarm (Outputs unchanged)  
CA = Serious external alarm (i1F=bAL) (All outputs OFF)

### Alarm Recovery

Probe alarm "P1" starts a few seconds after the fault in the related probe and stops a few seconds after the probe restarts normal operation (check connections before replacing the probe). Temperature alarms "HA" and "LA" automatically stop as soon as the temperature returns to normal. Alarm "CA" (with i1F=PAL) recovers only by switching the unit off and then on again.



# Operating Instructions

## Viewing and setting the desired temperature or “SET POINT”:

*To view the current set point value:* Push and immediately release the SET key the display will show the value. Wait 5 seconds or push SET again to return to the previous display.

*To change the set point value:* Press and hold the SET key until the °C or °F indicator light starts blinking. You are now in programming mode and have 10 seconds to begin adjusting the desired temperature. Use the UP or DOWN button to adjust the value, then press SET again or wait 10 seconds to save the new desired temperature.

## Manual Defrost:

*To start a manual defrost:* Push and hold the DEF key for at least two seconds. *Note:* By default the unit will defrost once every 24 hours

## Key Combinations:

- ▲ + ▼ Locks and unlocks the keyboard.
- SET + ▼ Enters programming mode.
- SET + ▲ Returns to the room temperature display.

*Note: these operating instructions are all most users will ever need to operate their unit, however more advanced features are available. for the complete operating instructions go to [www.vinotemp.com/winemate-operating.html](http://www.vinotemp.com/winemate-operating.html)*

## Use & Temperature Control

### Bottle Loading:

- Load wine bottles starting from the bottom locating the bottles evenly from left to right. This will prevent the cellar from shifting and potentially knocking the doors out of alignment.
- Keep the rack open every few bottle spaces to allow free airflow.
- Loading the cellar with no more than two cases per day will allow the cooling system to rapidly cool the wine to it's desired temperature.

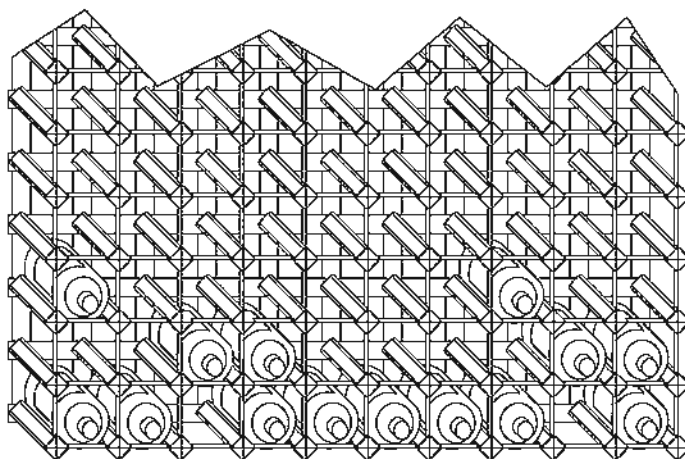

### Temperature Control:

- Set the temperature at 55 °F for the optimum aging of wine.
- Set the temperature higher when the ambient temperature is very high.
- On initial start-up, the time required to reach the desired temperature will vary, depending on the quantity of bottles, temperature setting and surrounding temperature.
- Allow at least 24 hours to stabilize the temperature for each new temperature setting operation.

## Maintenance

A Vinotemp wine cellar is a relatively low maintenance appliance, however there are a few simple procedures that will help to keep your cellar working at it's optimum for years to come.

### Coil Cleaning

Cleaning the condenser coil regularly will ensure an unobstructed flow of air into your cellar. The coil is located on the back of the cooling unit. Make sure that the cellar is unplugged before attempting to clean. A standard vacuum cleaner with an extended attachment should be used.

### Condensation Removing

Sometimes during normal operation of the cellar, condensation will form inside which will need to be cleaned off. This happens during periods of high temperature and humidity, however, too much condensation could also indicate other problems (see troubleshooting on next page)

### Gasket Care

If the cabinet's cooling system is running continually without reaching the desired temperature, the problem may lie with the door gaskets not sealing correctly.

Examine the door gasket around the entire unit. You may also note this by turning on the interior light and turning off the lighting in the room. Determine if there is an area which is not sealing properly. If a problem exists, use the following guidelines to resolve the problem:

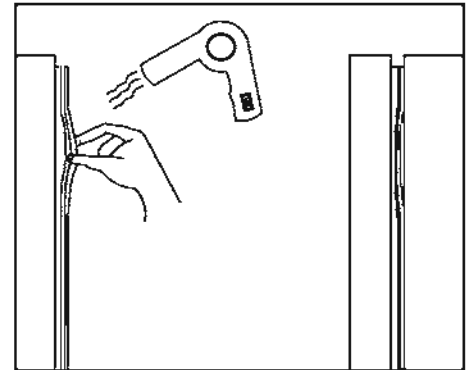

Using a hair dryer, heat the gasket up while using your fingers to pull the gasket outward. Doing this for several minutes will loosen the gasket material and increase its flexibility.

Then close the door and determine if the magnetic strip within the gasket will seal with the metal strip on the door. Repeat this process until gasket seals correctly. Once it has leave the doors closed for two to three hours. The seal should retain the new shape after this process.

### Door Warping

Our unfinished wood cabinets are not warranted against warpage. Because the grain of the wood is not sealed there is a potential for warpage to occur, this is why it is not recommended to request your cabinet in this style. Fortunately the effects of door warpage can be minimized with the following procedure.

In case of warpage, leave door open to expose both door surfaces to the same outside condition for 24 to 48 hours. To accelerate the process, wet the contracted (dry) door panel with a damp towel or sponge and allow drying with both door sides exposed.

To prevent future warpage, thoroughly seal the outsides of a straight door with two coats of high quality moisture proof wood sealant, so as to prevent any further moisture exchange.

Never seal a warped door, as it might be impossible to correct the condition after treatment. Vinotemp is not responsible for reversible moisture induced warpage of unfinished doors or for doors stained, and/or sealed after shipment from the factory.

# Troubleshooting

Complaint	Possible Causes	Response
<b>1. Unit not running</b>		
	<ul style="list-style-type: none"> <li>a. Power cord unplugged</li> <li>b. No power to unit</li> <li>c. Temperature setting high</li> <li>d. Low voltage.</li> <li>e. Incorrect or loose wirings.</li> <li>f. Defrost light blinking</li> <li>g. Running light blinking</li> </ul>	<ul style="list-style-type: none"> <li>a. Check for power cord plug</li> <li>b. Check power at receptacle &amp; fuses</li> <li>c. Lower temperature setting</li> <li>d. Contact an authorized electrician</li> <li>e. Check all wirings and connections</li> <li>f. Under defrost</li> <li>g. Call service for failed components</li> </ul>
<b>2. Compressor stopping and starting but short running time</b>		
	<ul style="list-style-type: none"> <li>a. Incorrect temperature setting</li> <li>b. Incorrect voltage</li> <li>c. Failed thermistor</li> <li>d. Failed components</li> <li>e. Improper condenser airflow</li> <li>f. Dirty condenser</li> <li>g. Overcharge of refrigerant</li> <li>h. Discharge or suction pressure too high</li> </ul>	<ul style="list-style-type: none"> <li>a. Set 55 to 60 °F</li> <li>b. Check for voltage</li> <li>c. Check thermistor by placing it in ice water and measuring resistance</li> <li>d. Check compressor windings, start relay and overload protector.</li> <li>e. Check for condenser fan</li> <li>f. Clean condenser</li> <li>g. Call service for removing refrigerant</li> <li>h. Call service for OEM information</li> </ul>
<b>3. Fan motor running but compressor not running</b>		
	<ul style="list-style-type: none"> <li>a. Incorrect power supply</li> <li>b. Incorrect or loose wirings</li> <li>c. Failed components</li> <li>d. Liquid refrigerant in the compressor</li> </ul>	<ul style="list-style-type: none"> <li>a. Check for proper voltage</li> <li>b. Check all wirings and connections</li> <li>c. Check start relay, start capacitor, overload protector, compressor.</li> <li>d. Call service for OEM information.</li> </ul>
<b>4. Compressor running but fan not running</b>		
	<ul style="list-style-type: none"> <li>a. Fan blade bond</li> <li>b. Incorrect or loose wirings</li> <li>c. Failed motors</li> </ul>	<ul style="list-style-type: none"> <li>a. Check for proper clearance</li> <li>b. Check all wirings</li> <li>c. Call service for checking open or shorted windings</li> </ul>
<b>5. No cooling but compressor and fan running</b>		
	<ul style="list-style-type: none"> <li>a. Evaporator airflow restriction</li> <li>b. Refrigerant leakage</li> <li>c. Refrigeration system restriction</li> </ul>	<ul style="list-style-type: none"> <li>a. Check for airflow through evaporator</li> <li>b. Check for loss of refrigerant</li> <li>c. Call service for checking restrictions</li> </ul>
<b>6. Temperature too high or unit running too long</b>		
	<ul style="list-style-type: none"> <li>a. Improper evaporator or condenser airflow</li> <li>b. Dirty Condenser</li> <li>c. Iced evaporator</li> <li>d. Malfunctioning fans</li> <li>e. Improper seals</li> <li>f. Improper area to be cooled.</li> <li>g. Low voltage</li> <li>h. Operating 60 Hz unit at 50Hz</li> <li>i. Sealed system problem</li> <li>j. Undercharge or overcharge</li> </ul>	<ul style="list-style-type: none"> <li>a. Check for air restrictions</li> <li>b. Clean condenser</li> <li>c. Defrost and reset temperature</li> <li>d. Check for both fans</li> <li>e. Check for gasket and door opening</li> <li>f. Check for excessive load incorrect installation</li> <li>g. Check power supply</li> <li>h. Use proper 60 Hz</li> <li>i. Call service for checking loss of refrigerant or restrictions</li> <li>j. Call service to add or remove refrigerant</li> </ul>
<b>7. House circuit tripping</b>		
	<ul style="list-style-type: none"> <li>a. Incorrect fuse or breaker</li> <li>b. Incorrect wirings</li> <li>c. Failed components</li> </ul>	<ul style="list-style-type: none"> <li>a. Check for proper fuse or breaker</li> <li>b. Check for wirings and connections</li> <li>c. Call service</li> </ul>
<b>8. Noisy operation</b>		
	<ul style="list-style-type: none"> <li>a. Mounting area not firm</li> <li>b. Loose parts</li> <li>c. Compressor overloaded due to high ambient temperatures or airflow restriction</li> <li>d. Malfunctioning components</li> </ul>	<ul style="list-style-type: none"> <li>a. Add support to improve installation</li> <li>b. Check fan blades, bearings, cabinet washers, tubing contact and loose screws.</li> <li>c. Check for airflow blockage</li> <li>d. Call service for checking Internal loose, inadequate lubrication and incorrect wiring.</li> </ul>

## Cellar Disassembly/Reassembly

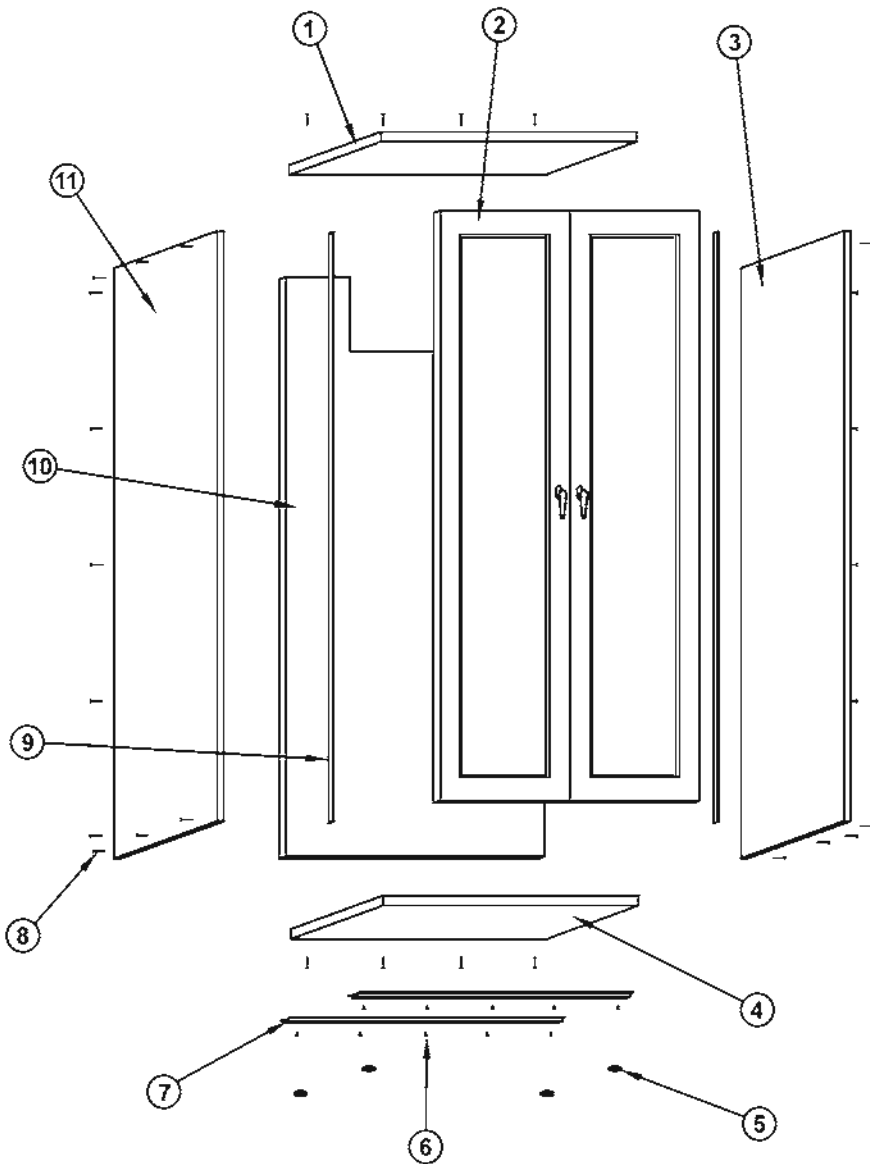

1. Top Panel
2. Door(s)
3. Right Panel
4. Bottom Panel
5. Foot
6. Screws (used for #7)
7. Bottom Metal
8. Screws (used for panels)
9. Hinge(s)
10. Rear Panel
11. Left Panel

### Tools required for disassembly:

- 7/16" wrench
- Phillips screwdriver
- 4mm hex wrench (allen wrench)
- 1/4" Nut driver

*Note:* 2-3 people are required to complete cellar disassembly. Remove racking first. Also some units are equipped with a horizontal stabilizing bar which must be removed first.

1. Remove shipping carton and packing material with exception of the pallet. Open door and remove the plastic bag containing four or six casters depending on the size of the unit.
2. Place the cardboard on the ground behind the wine cellar.
3. With the 7/16" wrench, remove the three bolts at the top of cooling unit. Carefully slide the unit out and place it on the ground out of the way in an upright position, being careful not to damage the insulated bottom.
4. On some 700's, remove the vertical middle bar by removing center screw in back brace, then remove screws on top and bottom of middle bar.
5. Carefully remove the screws that are on the cabinet side of the hinge making sure someone is holding the door while screws are being removed. Place the door on cardboard to the side of the wine cellar.
6. With the phillips screwdriver or 1/4" nut driver carefully remove the screws holding the bottle racks, be sure to save the screws which are located in the top back of the rack. Remove entire rack. (standard cellar trellis racks)  
*Note:* Models with horizontal support bar (single door 440 and single door 400E); the bar must be removed prior to removing rack.
7. Carefully tilt the unit back and place on the cardboard packing or padding to avoid damaging the cabinet.
8. With the 4mm wrench, carefully remove bolts on the side of the cabinet and place side on cardboard.
9. Having someone holding the top and bottom ends, remove bolts on the other side. Place the side on cardboard.
10. Remove the bolts at top of unit. Place top on cardboard.

**For re-assembly follow instructions in reverse**

## Wine-Mate Installation

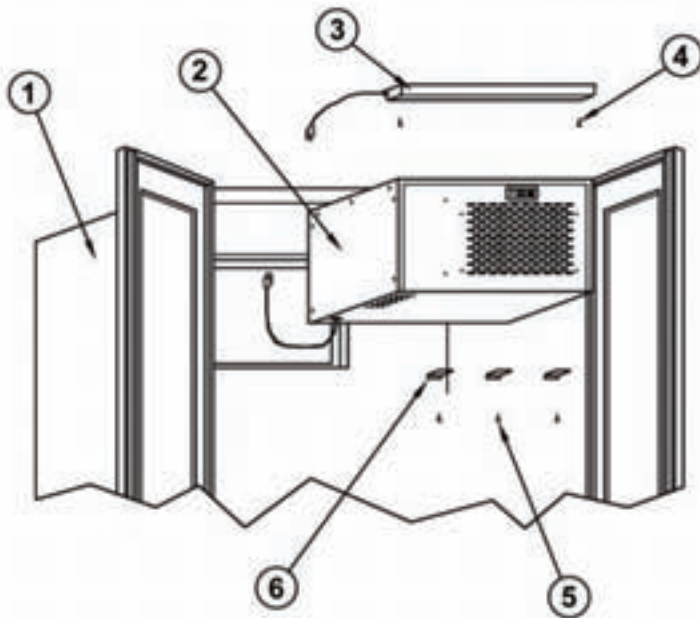

1. Cellar
2. Cooling Unit
3. Light
4. Screws for Light
5. Screws for Bracket
6. Bracket

### Wine-Mate Removal:

1. Unplug the cellar from the wall and the light
2. Remove light screws and light
3. Remove 3 bracket screws and brackets (this is all that supports the unit so an assistant will have to support it during removal)
4. Slide unit toward front of cellar and remove

### Installation Guidelines:

Wine-Mate is extremely proud of the reliability of its products. Experience has shown that of the small number of problems that occur, most are due to improper unit selection or enclosure construction. If the unit is suspected of malfunction, please refer to the troubleshooting guide on page 8.

Before installing your new unit, plug it in and test it for 15 minutes, there should be warm air flowing out the back (or top depending on configuration) and cool air out the bottom. The unit should be installed as near the top of the cabinet as possible, centered, and should have an unobstructed area of 3 feet to exhaust into, also the cool air should not be obstructed out the bottom of the unit. All openings should be sealed with high quality weather stripping. Once installed plug unit into a grounded wall outlet. The use of an extension cord is strongly recommended against.

### Specifications

Unit	Capacity	Dimensions (WxHxD)	Electrical	Weight
1500-CD	1500BTUH	18" x 10.5" x 16.5"	115V 60HZ 4A	50 lbs
2500-CD	2500BTUH	18" x 10.5" x 16.5"	115V 60HZ 5A	55 lbs
1500-HTD	1500BTUH	18" x 10.5" x 16"	115V 60HZ 4A	55 lbs
2500-HTD	2500BTUH	18" x 10.5" x 16"	115V 60HZ 5A	60 lbs
Grille (both)		19.875" x 12.5 x .25"		

### Air Flow Diagrams

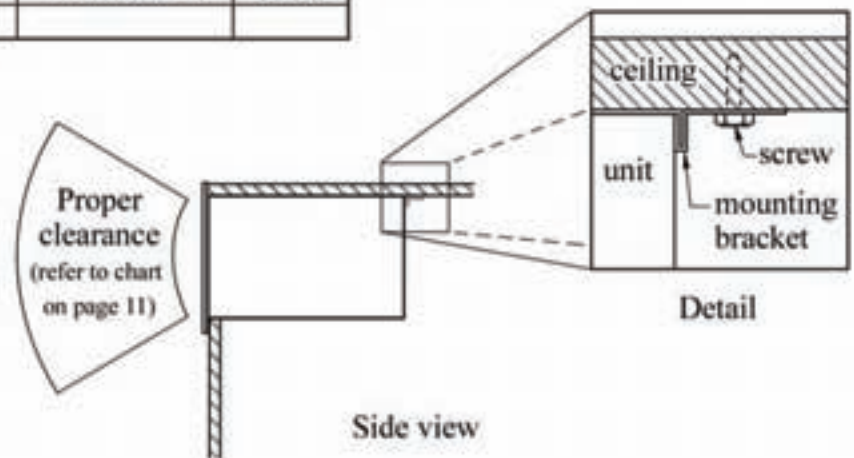
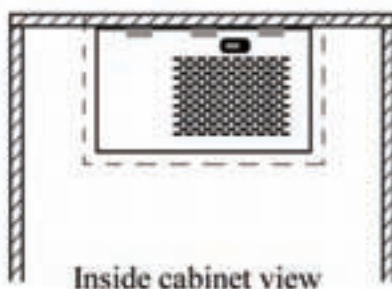
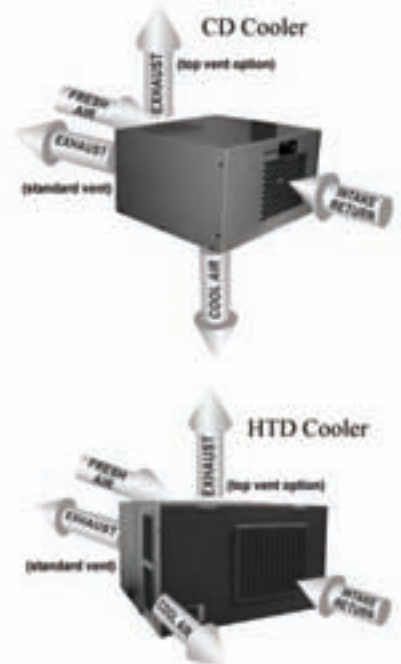



## Frequently Asked Questions

**Where are Vinotemp Wine Cellars made?** In Rancho Dominguez, California, near North Long Beach, Carson and Compton (20 minutes from LAX).

**What are Vinotemp wine cellars made of?** Handmade in wood. We usually use white oak exteriors, but the new Economy ("E") line and the WC-Series uses Luan Mahogany for the exterior.

**What is the insulation factor?** The "R" factor is approx. 11.6 because the Vinotemp walls are 1 3/4 inches thick, filled with rigid board insulation with a vapor barrier on each side to keep the cold air in and the hot air out.

**What kind of cooling system is used?** The very best money can buy, the "WineMate" have been engineered two years before the initial production, a combination cooling-humidifying unit, heavy duty and efficient.

**What is the BTU on standard models?** Unless upgraded, most cabinets come standard with the WM-1500CD cooling unit which is 1500BTU. For all cooling units the model number corresponds with the BTU rating (except 220-Volt systems). We offer cooling units from 1500BTU to 8500BTU. Check online for current units and pricing information at [www.vinotemp.com](http://www.vinotemp.com).

**What is the interior cubic footage of Vinotemp wine cellars?**

- 700-Series = 60 cubic feet
- 440-Series = 45 cubic feet
- 250-Series = 28 cubic feet

**What is the electrical requirement?**

115-Volt/60Hz for domestic units and 220Volt/50Hz for exports For all units a dedicated 15 Amp wall outlet is suggested(except the 6500 and 8500 BTU units which require a larger outlet), and neither a Ground Fault Interrupter (GFI) or an extension cord is recommended. Refer to the chart (right) for more info on specific units.

Model	Amperage
1500 BTU	4 AMPS
2500 BTU	5 AMPS
3500 BTU	8 AMPS
4500 BTU	9 AMPS
6500 BTU	14.2 AMPS
8500 BTU	16 AMPS

**Which is the ideal temperature for aging wines gracefully?** 55F to 58F. Wines will age faster at higher temperature.

**What should be the distance between the cabinet and the back wall?** That depends on the type of exhaust system that you have. Please refer to the following chart to determine the proper ventilation:

Exhaust type	Clearance Required
Top Exhaust	8"-12" on top and 2" in the back and on both sides
Side Exhaust	8"-12" on the side it will exhaust (left or right)
Front Exhaust	12" of clearance in front of the cabinet
Rear Exhaust	12" on top and on both sides and 6" in back

**Can a Vinotemp unit be installed in a closet?** Yes, but the closet must be large enough and have a louver door installed to let the air circulate.

**What if the floor is not level?** All Vinotemp have either four or six levelers built in. The legs can be adjusted to a range of up to one inch.

**What kind of wine racks are used in Vinotemp wine cellars?** Yes- the Famous Cellar Trellis wine racks made of dry solid wood and metal bracing, very strong, durable and pleasing to the eye. We also make redwood wine racking (as an option).

## More FAQ's

**What size of bottles will fit in Vinotemp Cellars?** Most 750ml bottles will fit in our standard 3 3/4" racking

**Can you make customize racking?** Yes, for example half of the cabinet could be 3 3/8" to maximize storage, a capacity, a quarter could be standard and the rest could be 4" or 4 1/2" for larger champagne and magnum bottles.

**Can a Vinotemp wine cellar be dismantled and reassembled inside?** It is sometimes done when turns are too sharp, when the unit does not fit, or a diagonal does not clear the ceiling. We supply a dismantling kit and instructions. It takes approximately 60 to 90 minutes to disassemble and reassemble inside.

**Do you use magnetic doors?** Yes, we use magnetic gaskets with 360° with stainless metal strips.

**Can I control the temperature?** Yes.

**Are Vinotemp space saving units?** Yes, definitely for example the Model 700 holds 440 bottles or 36 cases. Thirty six cases would take over ten feet of wall space if stacked four cases high however, the cabinet is only just over 4 feet wide.

**Do you have restaurant models of Vinotemp?** Our wine cellars can be used by restaurants, hotels, country clubs, etc. They can even be NSF certified (an additional cost)

**What temperature do you recommended for white and red wines?** For both red and white, we recommend 55 °F. Place the reds on top, the whites on the bottom. The cold air is heavier and warmer air rises.

**Can you hand customize a wine cellar?** Yes, this is our specialty. Any size, any style, any shape, any wood, any color. Just give us the dimensions and specifications, we do the rest.

**Do you have different designs?** Yes we have 18 kinds of glass doors, thermal, dual pane, vacuum sealed and tempered glass; 46 kinds of beveled doors and windows of great beauty; and one hundred kinds of carved doors and laminates.

**Can I pick up my wine cellar at the factory?** Yes you can. We will load it up with a signed release.

**How do you ship the wine cellars?** In Southern California from Santa Barbara to San Diego and Bakersfield to Palm Springs, we use Action Delivery Express. For the rest of the country Bekins Van Lines delivers and provides normal installation. Action Delivery Express will accept checks. The van lines accept only CASH OR CASHIERS CHECK

**Do you have many options?** We have an extensive number of options. See the price list.

**Do you ship anywhere in the world?** Yes we do.

**Can you finish the cabinets to customer specifications?** Yes. Have the customer give us a sample and we will try to match it.

**Do you also make walk in wine cabinets?** Yes, we do, in any size from 600+ bottles to 20,000 bottles or more. Our modular panels are fully insulated. It will take two men a full day to assemble one, including floor, walls, ceiling, cooling system, door, lighting wine racks, and case racks.

**Do you have different voltage systems?** Yes we do. We do have the standard 115 volt 60Hz for the U.S., Canada and many countries. We also have the 220 volt 50 Hz for Europe and many other countries.

**What size cubicles do you make?** 3 3/8" for traditional Reds; 3 3/4 for Reds and Whites including French Burgundies; 4" cubicles for Champagne, Dom Perignon etc; 4 1/2" cubicles for Magnums. The 750ml will fit into the 4", they will not fit and go through on the 4 1/2 inch cubicles. For splits (375ml) we recommend using a 3" cubicle.

## TERMS AND CONDITIONS OF SALE:

Vinotemp International ("Seller") and the person or entity that acquires these goods from Seller ("Purchaser") hereby fully agree to the following terms and conditions of the sale: Shipping fees are the responsibility of the Purchaser whether freight prepaid or freight collect. Seller assumes no responsibility for the goods sold to the Purchaser once the goods have left the Seller's premises, including, but not limited to, late delivery by the moving carrier, or for events caused by any difficulty carrier incurs in attempting to fit the goods into the Purchaser's place of business or residence due to the size of the goods or otherwise. Purchaser assumes all responsibility for delivery, payment of freight, access, measurement, installation, hook-up, wiring, moving and storage of the goods. The transportation of all goods is subject to the terms and conditions which the moving carrier imposes on Purchaser including, but not limited to, additional charges imposed per flight of stairs, and/or additional charges resulting from the carrier's inability to safely and/or adequately use the building elevator to lift the goods to an upper floor. Any claim for damages incurred during shipment by the carrier of the goods are insured and handled directly with the carrier. Any damages due to manufacture defects will be handled directly with Vinotemp International, subject to the limited warranty.

All sales are final, and unless authorized in writing by the Seller, Purchaser may not return the goods, under any circumstance. If Purchaser refuses to accept the goods, under any circumstance, the Purchaser is liable for the return and cost of freight both ways, and if Seller does take back the goods, there will be a restocking charge that is 35% of the purchase price of the goods. Custom Cabinet and Racking are non returnable. Purchaser must notify Seller of non-conforming goods within four days of delivery, after which time all goods are deemed accepted. If an order has been placed and production has started, cancellation of your order will be a 15% charge.

If Purchaser tenders payment with a check that has insufficient funds (NSF), or stops payment on a check or credit card for any reason, Purchaser agrees to pay for all costs associated with the Seller's connection or litigation of such a claim, including without limitation extra damages, court costs and attorneys' fees. Finance charges begin the date of invoice. Collection fees plus NSF fee of 50\$ will be added to your invoice, which you agree to promptly pay. Title to the goods does not pass until payment is received in full by Seller and Seller retains a security interest in the goods until they are paid for in full.

**LIMITED WARRANTY:** Seller warrants that the goods will be free of defects in materials and workmanship as follows: Furniture style (wood) wine units: all cooling unit parts for a period of 5 (five) years; cabinetry and labor (uninstalled) for a period of 12 (twelve) months from date of sale, removal and re-installation of unit is not included in warranted labor. For the metal cabinet wine units: parts and labor for cooling system and cabinetry for a period of 12 (twelve) months from date of sale, removal and re-installation of unit is not included in warranted labor. For a scratch and dent or refurbished unit, warranty is 3 months from your dated invoice (parts for function only, not cosmetic). Thermoelectric Units: 90 (ninety) days from the date of sale. (This includes Wine Coolers, Beer Dispensers and Refrigerators). Cigar Humidors and Racking Systems are not warranted. Split Systems and installed products are parts only for 1 year, no labor. There is no warranty on parts purchased separately. Purchaser's exclusive remedy is limited, at Seller's option; to repair or replace defective part[s] with either new or factory reconditioned part[s]. Purchaser is responsible for shipping the unit pre-paid to designated facility and Seller will pay return shipping charges in the continental United States for items repaired under warranty within 12 (twelve) months from date of sale. Since the natural variation in texture, density, grain, color, tone and shade of wood is unavoidable; Seller does not guarantee the texture, color, tone or shade of the wood; nor does seller guarantee the colorfastness of wood or against peeling, chipping, cracking or scratching. Note: Unfinished wood is subject to warping; all wood surfaces must be sealed before placing cellar into service. Improper placement of the unit will void the warranty. This limited warranty does not cover damage due to such things as accident, misuse, abuse, mishandling, neglect, acts of God, fires, earthquakes, floods, high winds, government, war, riot or labor trouble, strikes, lockouts, delay of carrier, unauthorized repair, or any other cause beyond the control of the Seller, whether similar or dissimilar to the foregoing. Seller is not responsible for any damages caused to Seller's property resulting from the good. This limited warranty applies only inside the Continental US. (Alaska, Puerto Rico and Hawaii are not warranted).

With Wine Mate products, if the customer calls and the product is "defective", you must obtain a letter from your qualified refrigeration technician at the customers cost, to verify that the unit was installed properly, with proper ventilation and the unit is truly malfunctioning due to manufacture defect.

Purchaser understands and acknowledges that the goods sold here are wine cellars, cigar humidors, and/or other similar units which house wine or cigars. Purchaser assumes all risk of using these units, including risk of spoilage, humidity variations, temperature variations, leaks, fire, water damage, mold, mildew, dryness and similar and any other perils that might occur.

Seller is not responsible for incidental or consequential damages, and there are no warranties, expressed or implied, which extend beyond the Limited Warranty described above. The implied warranties of merchantability and of fitness for a particular purpose are hereby expressly disclaimed. Some states do not allow the exclusion of incidental or consequential damages, or a waiver of the implied warranties of fitness and/or merchantability, so the above limitations may not apply to you. This warranty gives you specific legal rights and you may also have other rights which vary from state to state.

In the event of any dispute between Seller and Purchaser arising out of or relating to these terms and conditions or to the goods sold generally, Purchaser must first file a written claim with Seller within ten days of the occurrence giving rise to the claim and wait an additional thirty days for a response before initiating any legal action. The sale and all terms are subject to California law. Any legal proceeding arising out of or relating to these terms and conditions or to the goods sold generally shall be brought solely and exclusively in the County of Los Angeles. In no event may Purchaser initiate any legal proceeding more than six months after the occurrence of the event giving rise to the dispute.

The above terms and conditions are the only ones governing this transaction and Seller makes no oral representations of any kind. These Terms and Conditions can only be modified in writing, signed by both Purchaser and Seller. 04/07

## Free Manuals Download Website

<http://myh66.com>

<http://usermanuals.us>

<http://www.somanuals.com>

<http://www.4manuals.cc>

<http://www.manual-lib.com>

<http://www.404manual.com>

<http://www.luxmanual.com>

<http://aubethermostatmanual.com>

Golf course search by state

<http://golfingnear.com>

Email search by domain

<http://emailbydomain.com>

Auto manuals search

<http://auto.somanuals.com>

TV manuals search

<http://tv.somanuals.com>