

*it all
starts
with a
vision*

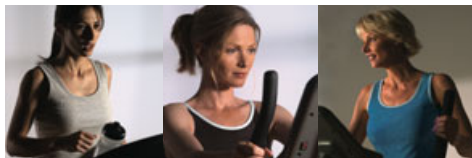

VISION  FITNESS.

500 South CP Avenue • P.O. Box 280 • Lake Mills, WI 53551
toll free 800.335.4348 • phone 920.648.4090 • fax 920.648.3373
www.visionfitness.com

©2007 Vision Fitness. All Rights Reserved. 1.07
AG18.51PRD
REV1

Assembly Guide

VISION  FITNESS.

X6150 AND X6250HRT
INCLINE ELLIPTICAL TRAINERS

TOOLS & PARTS INCLUDED

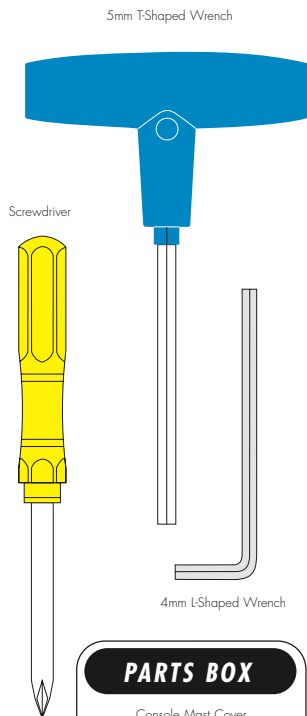



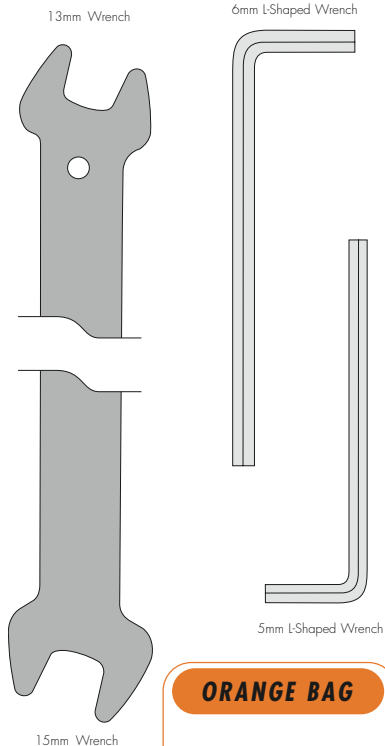

- PARTS BOX**
- Console Mast Cover
 - Accessory Tray/Water Bottle Cage
 - Color-coded Hardware Bags
 - Heart Rate Chest Strap (X6250HRT Only)
 - Power Cord
 - Owner's Guide
 - Assembly Guide
 - Warranty Card



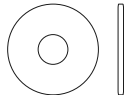









- ORANGE BAG**
- 
- M4x15L Screw
Quantity: 4

HARDWARE INCLUDED

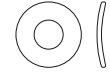
- BLUE BAG**
- 
- M8x20L Bolt
Quantity: 2
- 
- 8x25x1.5T Washer
Quantity: 2
- 
- M5x10L Bolt
Quantity: 6
- 
- 5x10x1T Washer
Quantity: 6
- 
- M5x12L Flathead Bolt
Quantity: 8

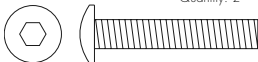
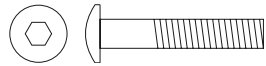
- PINK BAG**
- 
- M8 Lock Washer
Quantity: 5
- 
- M8x25L Socket Head Bolt
Quantity: 5
- 
- M5x12L Screw
X6250HRT Only
Quantity: 4
- 
- M8x10L Set Screw
Quantity: 2
- 
- 8x18x1.5T Arc Washer
Quantity: 1
- 
- 8x18x1.5T Flat Washer
Quantity: 4

- GREEN BAG**
- 
- 5x10x1T Washer
Quantity: 4
- 
- M8 Nut
Quantity: 2
- 
- M5x10L Bolt
Quantity: 4
- 
- Axle Sleeve
illustration not to scale
Quantity: 2
- 
- M8 Lock Washer
Quantity: 8
- 
- 8x18x1.5T Flat Washer
Quantity: 4
- 
- 8x18x1.5T Arc Washer
Quantity: 4
- 
- Spacer Ring
illustration not to scale
Quantity: 4
- 
- 8x25x1.5T Washer
Quantity: 2
- 
- M8x45L Fully Threaded Bolt
Quantity: 4
- 
- M8x45L Bolt
Quantity: 2
- 
- M8x60L Bolt
Quantity: 4

Assembly Guide

X6150 AND X6250HRT INCLINE ELLIPTICAL TRAINERS

To avoid possible damage to this Elliptical Trainer, please follow these assembly steps in the correct order. Before proceeding, find your new Elliptical Trainer's serial number located on the front axle tube, and enter here:

Refer to this number when calling for service, and enter this serial number on your Warranty Card and in your own records. Be sure to read your Owner's Guide before using your new Elliptical Trainer.
If any parts, hardware or tools are missing, please call 1.800.335.4348, Extension 12

NOTE: It is recommended that you apply grease to the threads of each bolt and screw as you assemble your Elliptical Trainer to prevent loosening and noise. Also, during each assembly step, ensure that ALL bolts and screws are in place and partially threaded in before completely tightening any ONE bolt or screw.

STEP 1 ORANGE BAG

- Slide the right transport wheel into the front tube. Align the holes in the front tube with the screw holes in the transport wheel sleeve. Insert two screws (M4x15L). Tighten with the screwdriver.
- Repeat these steps on the left side.

STEP 1

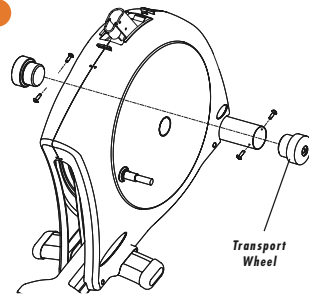

STEP 2 BLUE BAG

- Slide the knuckle joint sleeve of the right pedal arm assembly onto the pin on the right side cover disk. Secure in place with a washer (8x25x1.5T) and bolt (M8x20L). Tighten with the 5mm Thandle wrench.
- Slide the knuckle joint cover over the knuckle joint. Fix in place with a washer (5x10x1T) and a bolt (M5x10L). Tighten with the screwdriver.
- Attach a cover to the left and right side of the link arm connection joint. Fix each side in place with a washer (5x10x1T) and a bolt (M5x10L). Tighten with the screwdriver.
- Assemble the pedal footwell onto the right pedal arm with four flathead bolts (M5x12L). Tighten with the screwdriver.
- Insert the footwell cushion into the footwell. Make sure all pegs are seated into their respective holes.
- Repeat these steps on the left side.

Pedal Footwell

STEP 2

Knuckle Joint Sleeve

Knuckle Joint Cover

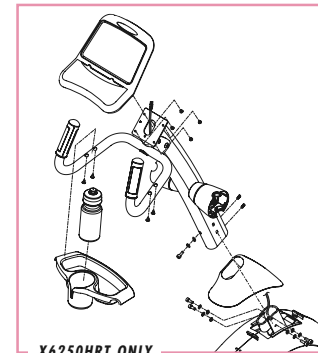

X6250HRT ONLY

STEP 2

BLUE BAG

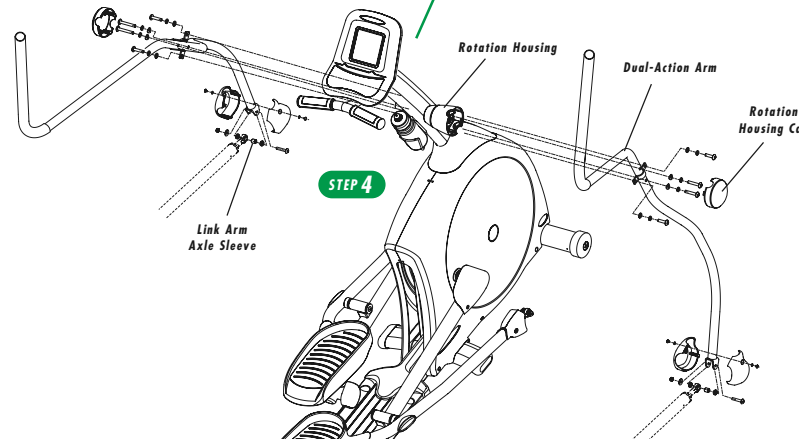

Link Arm Axle Sleeve

STEP 4

Rotation Housing

Dual-Action Arm

Rotation Housing Cap

STEP 3

PINK BAG

- Slide the console mast boot onto the console mast.
- Unwrap the wire harness located in the console mast frame bracket. Take the wire tie that exits the bottom of the console mast and wrap it around the end of the wire harness. Pull the wire tie up through the top of the console mast and slide the bottom of the console mast over the console mast frame bracket.
- Insert a socket head bolt (M8x25L) with a lock washer (M8) and a flat washer (8x18x1.5T) to each of the four mounting holes on the sides of the console mast. Insert a socket head bolt (M8x25L) with a lock washer (M8) and an arc washer (8x18x1.5T) to the mounting hole on the backside of the console mast. When all bolts are in place tighten the bolts with the 6mm L-shaped wrench. Insert two sets screws (M8x10L) to the nuts welded in the front side of console mast and tighten them with a 4mm L shaped wrench.
- Slide the console mast boot down in place over the frame covers.
- Remove the four mounting screws from the backside of the console. Plug the wire harness and heart rate wires into the back side of the console. Mount the console to the console mast with the four screws removed earlier in this step.

X6250 ONLY: Set the accessory tray on the console mast handlebars. Secure in place with four screws (M5x12L). Tighten with the screwdriver.
X6150 ONLY: Remove the water bottle cage mounting screws from the console mast with the screwdriver. Mount the bottle cage to the mast with these same screws. Insert water bottle.

STEP 4

GREEN BAG

- Line up the holes in the right dual-action arm with the holes on the right rotation housing. Insert two bolts (M8x60L), with a lock washer (M8) and an arc washer (8x18x1.5T), through the holes in the center of the dual-action arm and thread into the rotation housing. Next, insert two fully threaded bolts (M8x45L), with a lock washer (M8) and a flat washer (8x18x1.5T), through the flange on the side of the dual-action arm and into the rotation housing. Tighten all bolts with the 5mm Thandle wrench.
- Position the rotation housing cap over the dual-action arm and snap in place.
- Slide the axle sleeve through the socket joint on the right link arm. Slide a spacer ring onto each side of the axle sleeve.
- Slide the link arm axle sleeve between the teeth on the bottom of the dual-action arm bracket. Insert a bolt (M8x45L) through the dual-action arm bracket and link arm axle sleeve. Fix in place with a washer (8x25x1.5T) and nut (M8). Tighten with the 13mm wrench and 5mm L-shaped wrench.
- Attach a cover to the left and right side of the dual-action arm connection joint. Fix each side in place with the washer (5x10x1T) and bolt (M5x10L). Tighten with the screwdriver.
- Repeat these steps on the left side.

STEP 3

Console Mast

Console Mast Boot

Wire Harness

Console Mast Frame Bracket

Free Manuals Download Website

<http://myh66.com>

<http://usermanuals.us>

<http://www.somanuals.com>

<http://www.4manuals.cc>

<http://www.manual-lib.com>

<http://www.404manual.com>

<http://www.luxmanual.com>

<http://aubethermostatmanual.com>

Golf course search by state

<http://golfingnear.com>

Email search by domain

<http://emailbydomain.com>

Auto manuals search

<http://auto.somanuals.com>

TV manuals search

<http://tv.somanuals.com>