

# Visioneer Strobe XP 450 USB Scanner Installation Guide

FOR WINDOWS



# COPYRIGHT INFORMATION

Copyright © 2003 Visioneer, Inc.

Reproduction, adaptation, or translation without prior written permission is prohibited, except as allowed under the copyright laws.

The Visioneer brand name and logo are registered trademarks of Visioneer, Inc. The PaperPort brand name and logo are registered trademarks of ScanSoft, Inc.

Microsoft is a U.S. registered trademark of Microsoft Corporation. Windows is a trademark of Microsoft Corporation. TextBridge is a registered trademark of ScanSoft, Inc. ZyINDEX is a registered trademark of ZyLAB International, Inc. ZyINDEX toolkit portions, Copyright © 1990-1998, ZyLAB International, Inc. All Rights Reserved. All other products mentioned herein may be trademarks of their respective companies.

Information is subject to change without notice and does not represent a commitment on the part of Visioneer. The software described is furnished under a licensing agreement. The software may be used or copied only in accordance with the terms of such an agreement. It is against the law to copy the software on any medium except as specifically allowed in the licensing agreement. No part of this document may be reproduced or transmitted in any form or by any means, electronic or mechanical, including photocopying, recording, or information storage and retrieval systems, or translated to another language, for any purpose other than the licensee's personal use and as specifically allowed in the licensing agreement, without the express written permission of Visioneer.

Part Number: 05-0567-200

## Restricted Rights Legend

Use, duplication, or disclosure is subject to restrictions as set forth in contract subdivision (c)(1)(ii) of the Rights in Technical Data and Computer Software Clause 52.227-FAR14. Material scanned by this product may be protected by governmental laws and other regulations, such as copyright laws. The customer is solely responsible for complying with all such laws and regulations.

## Technical Support

Visit Visioneer's web site at [www.visioneer.com](http://www.visioneer.com) for technical support including help during installation, driver updates, spare parts, and documentation.

## Visioneer's Limited Product Warranty

If you find physical defects in the materials or the workmanship used in making the product described in this document, Visioneer will repair or (at its option) replace the product at no charge to you, provided you return it (postage prepaid, with proof of your purchase from the original reseller) during the **3-month period after the date of your original purchase of the product. Upon registration of the product with Visioneer at [www.visioneer.com](http://www.visioneer.com), the warranty is automatically extended for an additional 9 months for a total of 12 months.**

THIS IS VISIONEER'S ONLY WARRANTY AND YOUR EXCLUSIVE REMEDY CONCERNING THE PRODUCT, ALL OTHER REPRESENTATIONS, WARRANTIES OR CONDITIONS, EXPRESS OR IMPLIED, WRITTEN OR ORAL, INCLUDING ANY WARRANTY OF MERCHANTABILITY, FITNESS FOR A PARTICULAR PURPOSE OR NON-INFRINGEMENT, ARE EXPRESSLY EXCLUDED. AS A RESULT, EXCEPT AS SET OUT ABOVE, THE PRODUCT IS SOLD "AS IS" AND YOU ARE ASSUMING THE ENTIRE RISK AS TO THE PRODUCT'S SUITABILITY TO YOUR NEEDS, ITS QUALITY AND ITS PERFORMANCE.

IN NO EVENT WILL VISIONEER BE LIABLE FOR DIRECT, INDIRECT, SPECIAL, INCIDENTAL OR CONSEQUENTIAL DAMAGES RESULTING FROM ANY DEFECT IN THE PRODUCT OR FROM ITS USE, EVEN IF ADVISED OF THE POSSIBILITY OF SUCH DAMAGES.

All exclusions and limitations in this warranty are made only to the extent permitted by applicable law and shall be of no effect to the extent in conflict with the express requirements of applicable law.

## FCC Radio Frequency Interference Statement

This equipment has been tested and found to comply with the limits for the class B digital device, pursuant to part 15 of the FCC Rules. These limits are designed to provide reasonable protection against interference in a residential installation. This equipment generates, uses and can radiate radio frequency energy and if not installed, and used in accordance with the instructions, may cause harmful interference to radio communications. However, there is no guarantee that interference will not occur in a particular installation. If this equipment does cause harmful interference to radio or television reception, which can be determined by turning the equipment off and on, the user is encouraged to try and correct the interference by one or more of the following measures:

- Reorient or relocate the receiving antenna.
- Increase the separation between the equipment and receiver.
- Connect the equipment into an outlet on a circuit different from that to which the receiver is connected.
- Consult the dealer or an experienced radio/TV technician for help.

This equipment has been certified to comply with the limits for a class B computing device, pursuant to FCC Rules. In order to maintain compliance with FCC regulations, shielded cables must be used with this equipment. Operation with non-approved equipment or unshielded cables is likely to result in interference to radio and TV reception. The user is cautioned that changes and modifications made to the equipment without the approval of manufacturer could void the user's authority to operate this equipment.

This device complies with part 15 of the FCC Rules. Operation is subject to the following two conditions: (1) This device may not cause harmful interference, and (2) this device must accept any interference received, including interference that may cause undesired operation.

## TABLE OF CONTENTS

Welcome .....	1
What's in the Box .....	1
The Visioneer Strobe XP 450 Scanner .....	2
What You Need .....	3
Documentation .....	4
<b>Chapter 1: Installation</b> .....	<b>5</b>
Step 1: Assemble the Scanner .....	5
Step 2: Connect and Power On the Scanner .....	6
Step 3: Install the Software .....	7
Step 4: Connect the USB Cable .....	9
<b>Chapter 2: Scanning with the Scanner Button</b> .....	<b>11</b>
Load and Scan Documents .....	11
Configuring the Scanner Button .....	13
About the Configuration Dialog Box .....	13
Selecting New Settings for the Scanner Button .....	15
Creating a New Button Configuration .....	16
Editing Button Configurations .....	19
Setting Preferences .....	20
<b>Chapter 3: Scanning from PaperPort</b> .....	<b>22</b>
Your Scanner and the TWAIN Standard .....	22
If your computer is running Windows Me or XP .....	22
Load Documents into the Document Feeder .....	23
Scanning from Windows 98, Me, 2000, or XP .....	24
Adjusting the Image with the Scan Manager .....	28
Adjusting the Image Type, Resolution, Brightness and Contrast .....	28
Adjusting the Output Size .....	31
Setting the Scan Area .....	33

Reversing the Image .....	35
Adjusting Color and Gray Images .....	36
Adjusting Color Settings .....	38
Adjusting the Scanner's Power Saving Time .....	44
Scanning from Windows Me or XP .....	45
<b>Chapter 4: Maintenance</b> .....	50
Cleaning the Automatic Document Feeder .....	50
Clearing Paper Jams .....	51
Replacing the ADF Pad Assembly .....	52
Troubleshooting .....	53
Uninstalling Your Scanner .....	55
Step 1: Uninstalling the Visioneer OneTouch Software .....	55
Step 2: Uninstalling the PaperPort Software .....	56
Visioneer Strobe XP 450 Scanner Specifications .....	57
Visioneer Strobe XP 450 Scanner Parts List .....	58
<b>Index</b> .....	59

## WELCOME

Your Visioneer Strobe XP 450 USB scanner can quickly scan color and black and white documents and place their images on your computer.

---

**Warning:** Do not plug in the USB cable until after you have installed the software. Carefully follow the steps and sequence described in the installation procedure beginning on page 5.

---

## WHAT'S IN THE BOX

Before proceeding, check the contents of the box. If items are missing or damaged, contact the dealer where you purchased the scanner.

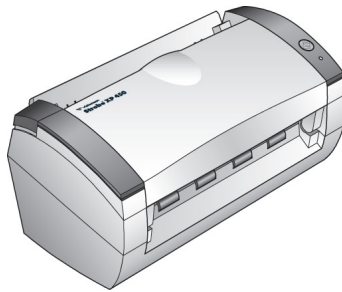

Strobe XP 450 Scanner

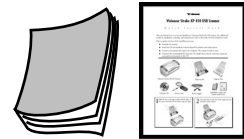

Installation Guide and  
Quick Install Card



Software CD

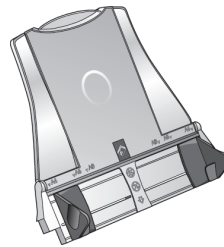

Paper Guide

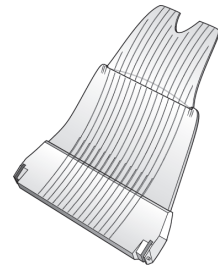

Output Tray



USB Cable



Power Supply



Power Cord

## THE VISIONEER STROBE XP 450 SCANNER

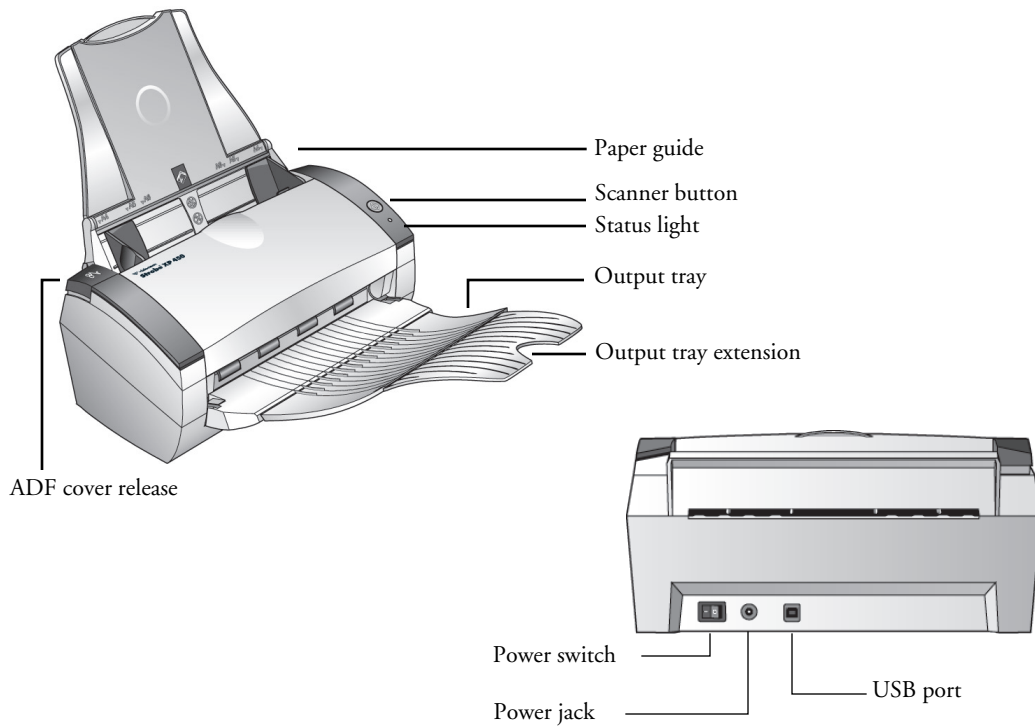

**Paper guide**—Holds documents in place. Adjusts to fit the document size.

**Scanner button**—Starts scanning using the scan settings button.

**Status light**—Shows the scanner's status. A flashing green light indicates the scanner is preparing to scan. A steady green light indicates the scanner is ready to scan. Refer to the Troubleshooting section for additional details.

**Output tray**—Holds documents after scanning through the ADF.

**Output tray extension**—Unfolded when scanning legal-sized documents.

**ADF cover release**—Opens the cover on the automatic document feeder.

**Universal Serial Bus (USB) port**—Connects the scanner to the computer.

**Power jack**—Connects the power cord to the scanner.

**Power switch**—Turns the scanner's power on and off.

## WHAT YOU NEED

### **An IBM-compatible PC with:**

- A CD-ROM drive
- An available Universal Serial Bus (USB) port
- Microsoft Windows operating system: 98, 2000, Me, or XP
- Available internal memory (RAM) as follows:
  - 64 megabytes (MB)
  - Windows XP—128 MB
- 200 MB of free hard disk space

---

**Note:** The new USB 2.0 ports operate at higher speeds than USB 1.1 ports. If your computer is not equipped with USB 2.0 ports, you can add them with the Visioneer Hi-Speed USB 2.0 PCI Card. Visit the Visioneer web site at [www.visioneer.com](http://www.visioneer.com) for ordering information, or contact the dealer where you purchased your Visioneer XP 450 OneTouch USB scanner. However, you do not have to add USB 2.0 ports to the computer. Your scanner automatically works with both USB 1.1 and USB 2.0 ports.

---

### **A VGA Monitor**

Recommended settings for your monitor are as many colors as possible—High Color (16-bit), True Color (24-bit or 32-bit). Set the resolution to at least 800 by 600 pixels.

To set your monitor's colors and resolution, open the Windows Control Panel, double-click Display, and then click the Settings tab.

## DOCUMENTATION

Your scanner is delivered with the following documentation:

- Quick Install Card—abbreviated installation instructions.
- Visioneer Strobe XP 450 Scanner Installation Guide—on the Installation CD; contains detailed installation, scanning, configuration, and maintenance information.
- ScanSoft PaperPort User's Guide—on the Installation CD; contains detailed feature and configuration information.
- Online Help—for the scanner configuration, Visioneer Scan Manager, and PaperPort software applications.



# Installation

---

**Warning:** Do not plug in the USB cable until after you have installed the software. Complete the installation steps in the order described in the installation procedure below.

---

Installation is a quick, four-step process:

1. Assemble the scanner
2. Connect and power on the scanner
3. Install the software
4. Connect the USB cable to your computer

## STEP 1: ASSEMBLE THE SCANNER

**To assemble the scanner:**

1. Remove all shipping tape from the top and bottom of the scanner.
2. Align the slots on the paper guide with the ridges on the scanner and slide it down until it snaps into place.

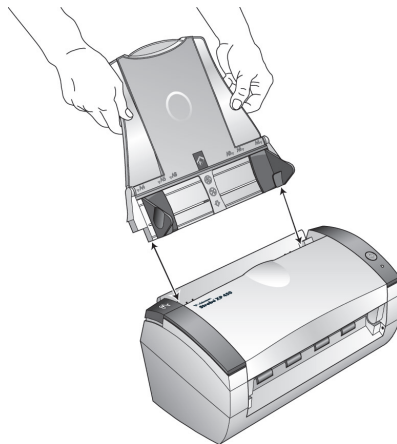

3. Insert the pins on each side of the output tray into the holes on the scanner.

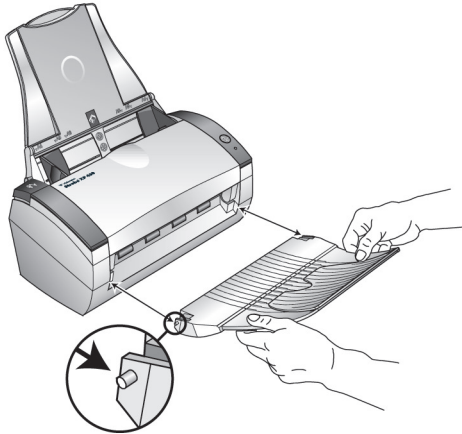

4. Proceed to “Step 2: Connect and Power On the Scanner”.

## STEP 2: CONNECT AND POWER ON THE SCANNER

Before installing the software, connect the power supply and power cord, and then turn the power on.

**To connect your Visoner Strobe XP 450 scanner:**

1. Plug the power supply into the power port on the scanner.



2. Plug the power cord into the power supply and into a wall outlet.

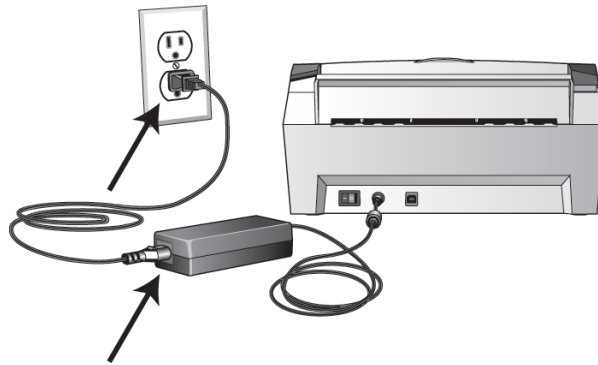

3. Turn on the power switch, located on the back of the scanner to the left of the power port.

The status light comes on and flashes indicating that the scanner is receiving power.

## STEP 3: INSTALL THE SOFTWARE

---

**Note:** You must install the software *before* connecting the scanner to your computer. Otherwise, the correct driver software for your scanner will not be installed and it may not work properly.

---

### To install the software:

1. Start Microsoft Windows and make sure no other applications are running.
2. Insert the CD into your computer's CD-ROM drive.

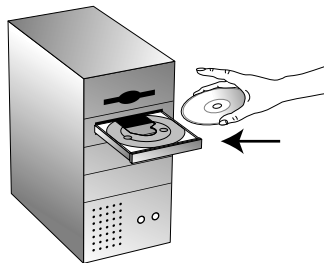

The CD automatically starts.

---

**Note:** If the CD does not start, check the following:

- Make sure the CD drive's door is completely shut.
  - Double-click the My Computer icon on your Windows desktop. Double-click the icon for your CD-ROM drive. From the list of files on the CD, double-click the file named START32.EXE.
- 

3. On the installation menu, select **Install ScanSoft PaperPort and Scanner Driver**.

If a message window opens instructing you to restart your computer, click **Restart**.

4. On the PaperPort 9.0 Welcome window, click **Next**.

5. On the License Agreement window, read the ScanSoft license agreement. If you accept the terms, select **I accept the terms in the license agreement**, and then click **Next**.

6. On the Customer Information window, accept the current values or enter new information, and then click **Next**.

7. On the Setup Type window, click **Next**.

8. Click **Install** to begin the installation.

9. On the Product Registration window, do one of the following:

- Select **Register online**, click **OK**, and then follow the registration instructions.
- Select **Print registration form**, click **OK**, and then follow the instructions to complete and print the registration form.
- Select **Remind me in 7 days** and click **OK**.

10. On the Visioneer License Agreement window, read the license agreement. If you accept the terms, select **I Agree**, and click **Next**.

11. On the Visioneer Product Registration window, complete the required information, and then click **Register**.

12. On the Welcome window, click **Next** to start the installation.

- When you see the Connect Scanner window, do **NOT** click Finish. Leave the window open and proceed to the next section, “Step 4: Connect the USB Cable”.

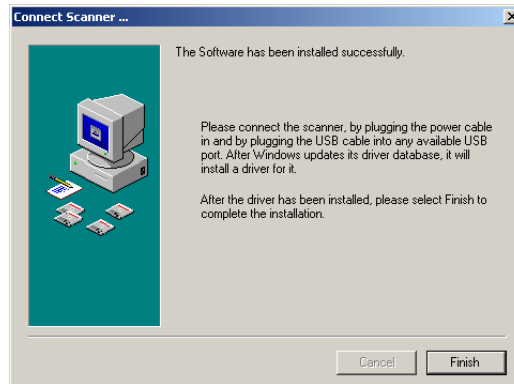

## STEP 4: CONNECT THE USB CABLE

The Visioneer Strobe XP 450 scanner connects to any available USB port. Check your computer's manual for USB port locations.

---

**Note:** You can connect the scanner to your computer while the computer is running. You do not have to shut down your computer.

---

- Plug the USB cable into the USB port on the scanner and then a USB port on the computer. The ports are identified USB symbols.

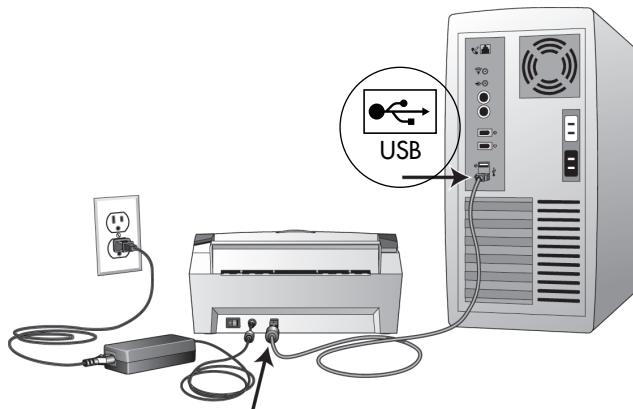

---

**Note:** You can also connect the scanner to a USB port on the computer's keyboard if it has one, or to a USB hub. If you use a USB hub, it must have its own power supply already plugged into an electrical outlet.

---

---

**Note:** If you have not installed the software, unplug the USB cable from the computer and install the software now. When the software installation is complete, a message tells you to connect the scanner.

---

---

**Note:** If you are using Windows XP and have plugged the USB cable into a USB 1.1 port, an information bubble opens explaining that "A HI-SPEED USB device is plugged into a non-HI-SPEED USB hub". Plug the USB cable into a USB 2.0 port (if available) or disregard the message. Refer to the Note on page 3 of this guide for more details.

---

Your computer recognizes that a scanner has been plugged into the USB port and automatically loads the appropriate software from the CD to run the scanner.

2. When the software is finished loading, return to the Connect Scanner window and click **Finish**.

The scanner's status light is green when the scanner and computer are communicating properly.

3. On the Install Completed window, click **Finish**.
4. When installation is finished, restart your computer.
5. If you removed the CD from the CD drive and want to install other software, reinsert the CD into the drive.

In addition to installing the other software from the CD, you can also view and print the User Guides and Installation Guide.

# Scanning with the Scanner Button

When you press the scanner button, your document is scanned using predefined scan settings and then the image is sent to a software application on your computer. To change scan settings, see “Configuring the Scanner Button” on page 13.

## LOAD AND SCAN DOCUMENTS

1. If you are scanning legal-sized documents, unfold the output tray extension.
2. Adjust the paper guide for the size of paper.

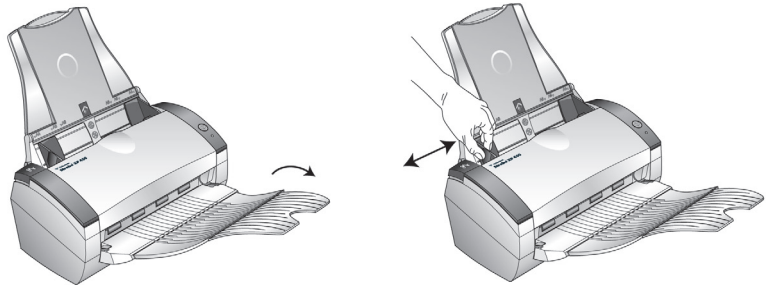

---

**Note:** Remove any staples or paper clips from the documents before loading them into the automatic document feeder. Staples and paper clips can jam the feed mechanism.

---

3. Load the documents face down, with their tops into the automatic document feeder.

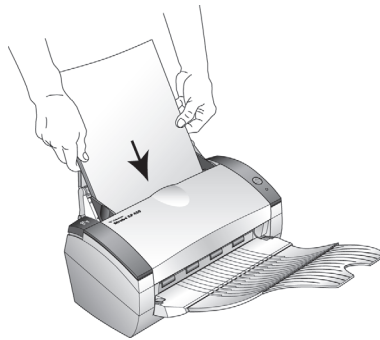

4. Press the button on the scanner.

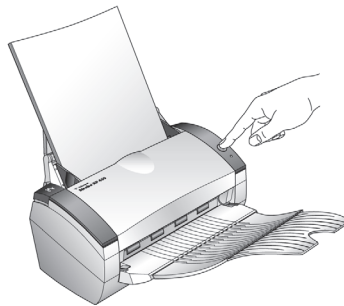

A scan progress window opens and then a thumbnail of the scanned image appears in the destination software. In the following example, the destination software is the PaperPort desktop.

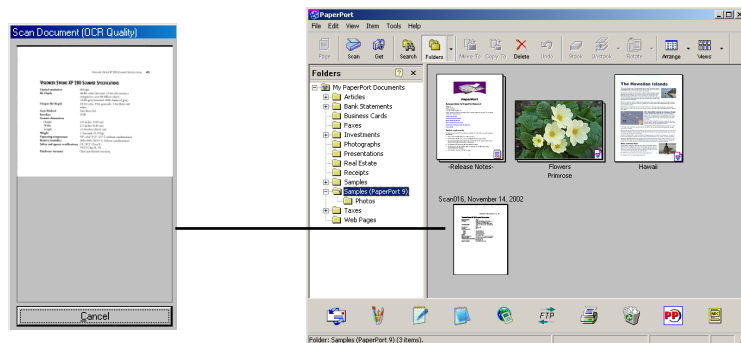



## CONFIGURING THE SCANNER BUTTON

When you first connect your scanner to a computer, the scanner's OneTouch software is configured to scan in black and white and send the scanned image to the PaperPort desktop. You can change the settings by selecting new options from the Configuration dialog box.

### To open the Configuration dialog box:

1. On the Windows taskbar, click **Start**, point to **Programs**, point to **ScanSoft PaperPort 9.0**, and then click **OneTouch Configure**.
2. If not already selected, click the Scan tab on the Configuration dialog box to display available scanning configurations.

### ABOUT THE CONFIGURATION DIALOG BOX

The Configuration dialog box manages settings for the scanner button. In the following figure, the button is set to scan with the configuration named Scan Document and then open PaperPort to display the scanned image. The Format and Page(s) option is set to scan in the PaperPort image format.

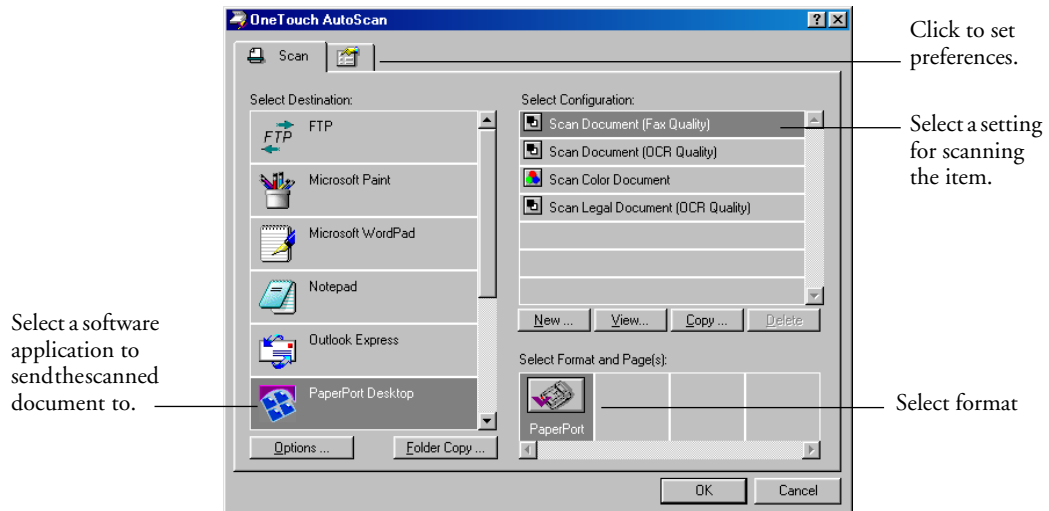

The options on the Configuration dialog box are:

**Select Destination**—the list of applications that can open to display the scanned image. To configure the list of available applications, click the Preferences tab at the top of the dialog box and select the desired option. See “Setting Preferences” on page 20 for more information.

**Select Configuration**—the list of available configurations. The configuration settings include: scanning mode, resolution, page size, contrast, and brightness. To see a selected configuration’s settings, click its icon. Click the icon again to close the detailed information.

Click the icon of a selected configuration to view its settings.

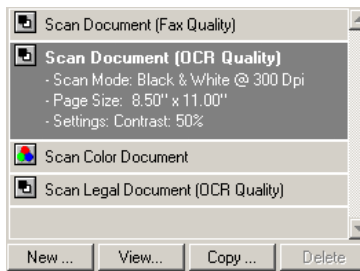

The icons next to each Configuration indicate the scanning mode:



Color



Black and White



Grayscale

You can also click the **View** button to see more detailed information about the selected configuration.

**Select Format and Page(s)**—a set of format for the scanned image. The formats are bitmap and PaperPort. Bitmaps are usually used for photos or artwork. The bitmap format is available when you select a destination application other than PaperPort.



**Options**—displays a dialog box for selecting options related to the selected destination application for the scanned image. Each destination application has its own options dialog box.

## SELECTING NEW SETTINGS FOR THE SCANNER BUTTON

You can select a new destination application, scanning configuration, and image format to use when you press the scanner button.

### To select new settings for the Scanner Button:

1. From the Select Destination list, select the application where you want scanned images sent.

See “Setting Preferences” on page 20 to display a full list of the destination applications that you can use with the scanner.

---

**Note:** If you select a word processing program such as Microsoft WordPad or Microsoft Word and a configuration for OCR, the text in scanned images is automatically converted to word processing text by the optical character recognition (OCR) software that you receive with the scanner. The converted text then appears in the selected destination application.

---

2. From the Select Configuration list, select a scan configuration.



To scan in color, select one of the configurations indicated by the small color icon, such as the Scan Color Document configuration.

The configuration list is preset for the application you select in the Select Destination list. If you select a different application, the configurations are for that application.

3. Select a Format and Page(s) option.
4. Click **OK**.

Now when you press the scanner button, the document is scanned using the new settings.

## CREATING A NEW BUTTON CONFIGURATION

You cannot change settings of the preset (default) configurations. To use settings other than those offered by the preset configurations, you must create a new configuration. You can do this either by copying a preset configuration and making the desired changes or by creating a new configuration from scratch.

### To create a new configuration:

1. Scroll the applications in the Select Destination list and click the application for which you want to create a new configuration.
2. Do one of the following:
  - Click the **New** button.
  - Select a preset configuration and click the **Copy** button.
3. On the New Scan Configuration dialog box, type a name.
  - If you are copying from a preset configuration, leave the name as is or change it as required.

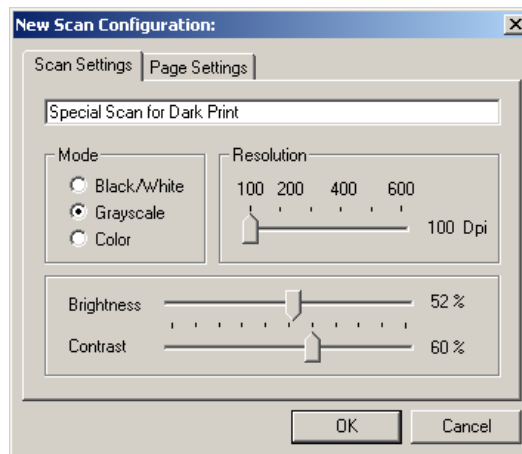

---

**Note:** If you select a printer or other device in the Select Destinations list, the dialog box may have an additional tab for setting specific options for the particular device.

---

- Select scan settings for the new configuration.

**Mode**—Select a scanning mode as follows:

- Black/White to scan in black and white. For example, letters and memos are usually scanned in black and white.
- Grayscale to scan items such as documents containing drawings or black and white photographs. The scanning produces an image in varying shades of gray.
- Color to scan color photographs and other color items.

**Resolution**—Drag the slider to the right or left to adjust the dots per inch (dpi) of the resolution. The maximum resolution is 600 dpi; the minimum is 100 dpi. The higher the dpi setting, the sharper and clearer the scanned image. However, higher dpi settings take longer to scan and produce larger files for the scanned images.

**Brightness and Contrast**—Drag the sliders to the right or left to adjust the brightness and contrast of the scanned image. The Contrast setting does not apply to the Black/White mode.

- Click the Page Settings tab to select page settings.

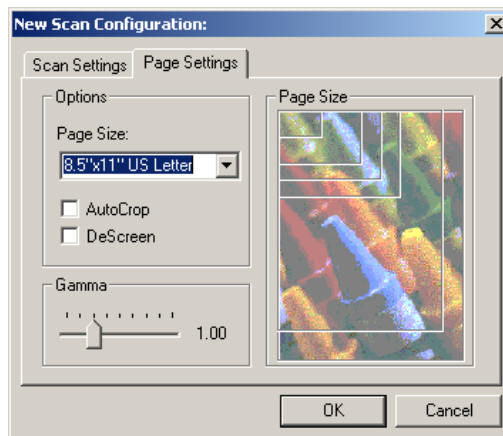

**Page Size**—Click a page size from the drop-down list. The outlines on the picture represent the various page sizes. Clicking one of those outlines also selects it as the page size for the scan. If you

select the Custom option from the drop-down list, boxes appear in place of the picture. Enter the horizontal and vertical page dimensions in the boxes.

**AutoCrop**—This option lets the scanner automatically determine the size of the item being scanned. For example, if you scan an unusual page size, the scanner will automatically determine the size of the page.

**DeScreen**—Select this option when scanning a picture from a newspaper or magazine article, or other items that contain images with patterns or dots. These patterns and dots sometimes cause a wavy appearance for which the Descreen option can compensate.

The following example shows the effect of descreening a scanned image from a magazine article.

Original Image



Descreened Image



The scanning may slow down a bit when descreen is selected. The DeScreen setting does not apply to the Black/White mode.

**Gamma**—Drag the slider to improve how the colors in a scanned image look on your monitor. Gamma correction allows you to achieve precise color matching. Because the computer cannot always transmit the exact color information to the hardware, you may have to make some color adjustments using the Gamma feature.

The default Gamma setting works fine in most cases and normally does not need to be adjusted.

6. Click **OK** to save the new configuration.

On the Configuration dialog box, make sure the configuration you just defined is selected.

7. To set the new configuration for use by the scanner button, select the configuration and then click **OK**.

## EDITING BUTTON CONFIGURATIONS

You cannot edit the preset button configurations; you can only edit those configurations that you created yourself.

### To edit a configuration:

1. Open the Configuration dialog box.
2. Select the configuration you want to edit. The selection must be a configuration you created.
3. Click the **Edit** button.

The Edit Scan Configuration dialog box opens.

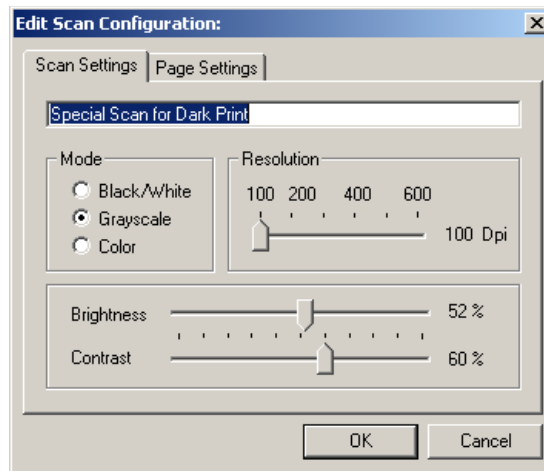

4. Edit the settings as required and click **OK**.
5. Click **OK** to close the Configuration dialog box.

## SETTING PREFERENCES

You can set general preferences for button and scanner functions.

### To set preferences:

1. Open the Configuration dialog box and click the Preferences tab.

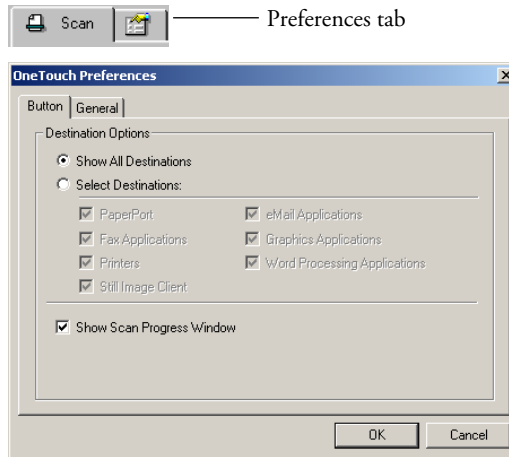

2. Select button preferences as described below.

**Show All Destinations**—This option selects all the destination application categories. The list of destination applications on the Configuration dialog box will include all the applications on your computer that fall into these categories. This is the default selection when the OneTouch AutoScan software is installed. The list also includes printers and other devices connected to your computer so, for example, you can scan an item and have it printed immediately.

**Select Destinations**—Select this option to individually choose the types of applications to include in the list of destination applications. Check the boxes for the type of application to include.

**Show Scan Progress Window**—Select this option to display a progress window of the document during scanning.



3. Click the General tab to set a temporary folder.

**Folder for Temporary Images**—Click the **Folder** button and then select a folder for the scanner's temporary images. During scanning, a temporary file contains scan information about the image. Because temporary image files can sometimes be large, select a folder that has sufficient disk space available.

4. Click **OK** to save the AutoScan preferences.

# Scanning from PaperPort

Instead of using the scanner button, you can scan from the PaperPort software application. Use this method if you want to preview an image and adjust scanning settings prior to scanning.

## **YOUR SCANNER AND THE TWAIN STANDARD**

Your scanner uses the TWAIN standard for scanning. TWAIN is a widely recognized methodology that computers use to receive images from scanners, digital cameras, and other digital devices. The PaperPort software application that you received with your scanner uses the TWAIN standard, and this guide shows how to scan with it. Many other graphics and imaging applications also comply with the TWAIN standard, so you can use your scanner with those applications too. To use your scanner with other TWAIN-compliant software, please refer to their user guides.

## **IF YOUR COMPUTER IS RUNNING WINDOWS ME OR XP**

Instead of using the TWAIN standard, your scanner can also use Microsoft's Windows Image Application (WIA) standard for scanning, which is also available from other applications. Therefore, you can use your scanner with other applications on a computer running Windows Me or XP too. See "Scanning from Windows Me or XP" on page 45.

## LOAD DOCUMENTS INTO THE DOCUMENT FEEDER

1. If you are scanning legal-sized documents, unfold the output tray extension.
2. Adjust the paper guide for the size of paper.

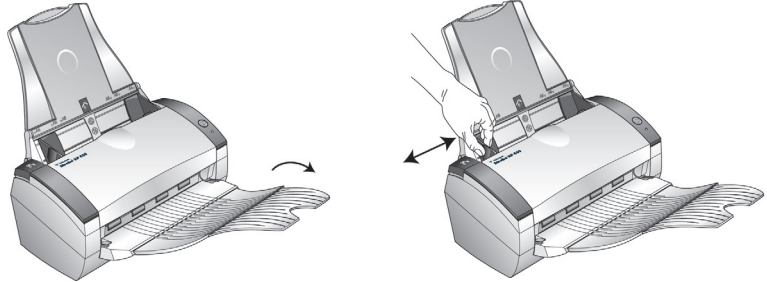

---

**Note:** Remove any staples or paper clips from the documents before loading them into the automatic document feeder. Staples and paper clips can jam the feed mechanism.

---

3. Load the documents face down, with their tops into the automatic document feeder.

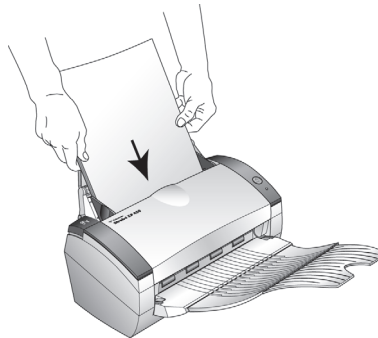

## SCANNING FROM WINDOWS 98, ME, 2000, OR XP

The instructions in this section are for scanning with the TWAIN software on computers running Windows 98, Me, 2000, or XP. If your computer is running Windows Me or XP and you want to use the WIA software, see “Scanning from Windows Me or XP” on page 45.

### To scan an item from PaperPort:

1. On the Windows taskbar, click **Start**, point to **Programs**, point to **ScanSoft PaperPort 9.0**, and then click **PaperPort**.

The PaperPort desktop opens.

Scan icon

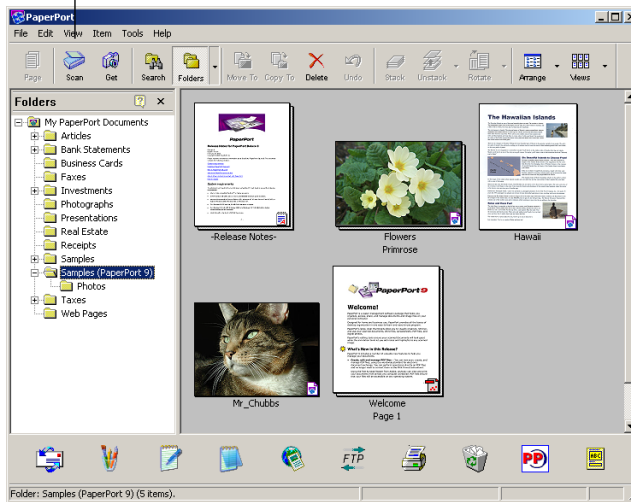

2. Click the **Scan** icon on the PaperPort command bar.

The Folders pane (which shows folders for organizing your scanned images) is replaced by the Scan pane.

## Scan pane

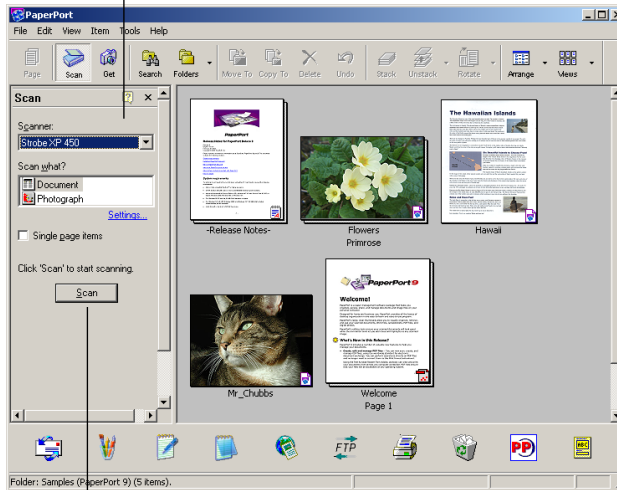

Opens the Scan Manager

3. From the Scanner drop-down list, select **Strobe XP 450**.
4. In the “Scan what?” section, choose to scan a **Document** or **Photograph**.
5. Click **Settings** to view and change the format for the scanned item’s file name and the file type. The default file type for documents is .pdf and the default for photographs is .jpg.
6. Use the **Single page items** check box as follows:
  - When the check box is selected, all pages in the document feeder are scanned and placed in a stack on the PaperPort desktop.
  - When the check box is not selected, all pages in the document feeder are scanned, but not placed on the PaperPort desktop until you close the Scan Manager and indicate the scanning job is finished.
7. Click the **Scan** button on the Scan pane.

The Scan Manager opens. Use the Scan Manager to select scanning options and to start the scanner.

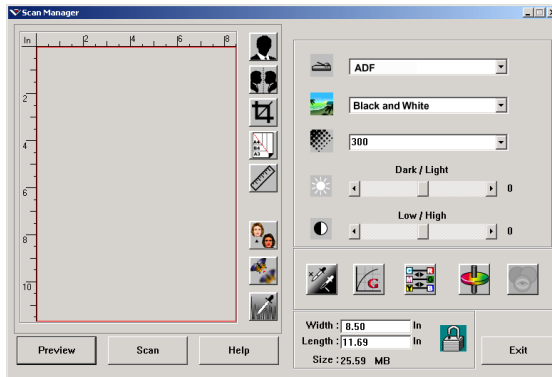

8. If you want to see what the scanned image will look like before scanning its final image, click the **Preview** button.

The scanner scans a preview of the item and displays it in the Scan Manager. You can now use the options on the Scan Manager to fine-tune the image. For details on adjusting images, see “Adjusting the Image with the Scan Manager” on page 28.

---

**Note:** If you preview when scanning a stack of documents, the first page of the stack feeds through the ADF for the preview. After adjusting the scanner settings, replace the page on the stack so it is scanned with the rest of the pages.

---

9. To preview the item with the new settings, click the **Preview** button again on the Scan Manager.
10. When you are satisfied with the preview image, click **Scan**.  
If the **Single page items** check box is selected on the PaperPort desktop, the item appears as a thumbnail on the desktop.
11. If the **Single page items** check box is not selected, thumbnails do not appear until you indicate the scanning job is finished.
  - Close the Scan Manager.
  - On the PaperPort - Scan message box, click **Done**.

---

**Note:** Refer to “The Single Page Items Check Box” on page 27.

---

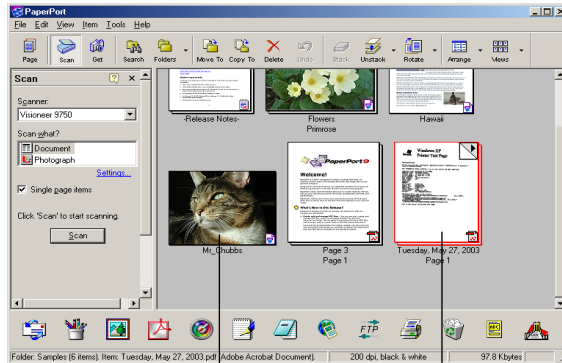

A thumbnail image of the scanned item appears on the PaperPort desktop

Thumbnail images of a stack of documents scanned with the ADF.

## ON THE PAPERPORT DESKTOP

- By default, the name of the scanned image is the day, date, and number of scanned items that day. For example, the second item scanned on a day is followed by a (2), the third by a (3) and so on. To change a name, click it to select its text and type a new name.
- The thumbnail images of the stack of documents has “go to page arrows” so you can click through the pages in the stack. The page counter next to the scroll arrows shows which page you’re viewing and the total number in the stack.

## THE SINGLE PAGE ITEMS CHECK BOX

The Single page items check box provides the option to add additional items to a scanning job and scan double-sided items. If the check box is selected, scanned items immediately appear on the PaperPort desktop. If the check box is not selected (this is the default), the following message box appears when you close the Scan Manager.

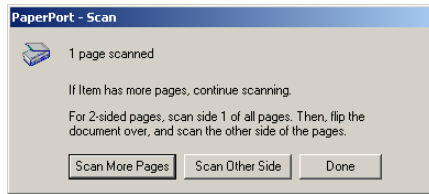

- Click **Scan More Pages** to scan additional pages and add them to the stack of items placed on the PaperPort desktop.
- Click **Scan Other Side** to reload and scan the other side of previously scanned pages. This option is only available once.
- Click **Done** if you are finished scanning. The scanned items are placed on the PaperPort desktop.

To learn more about the PaperPort software please see the *ScanSoft PaperPort User's Guide* on the Installation CD.

## ADJUSTING THE IMAGE WITH THE SCAN MANAGER

The Scan Manager has a wide variety of options to adjust your scanned images. Using those options you can produce the best possible scan of your documents, color photos, magazine articles, business cards, or any other items you scan.

## ADJUSTING THE IMAGE TYPE, RESOLUTION, BRIGHTNESS AND CONTRAST

The Scan Manager's drop-down lists and sliders are used to adjust the image type, resolution, brightness, and contrast.



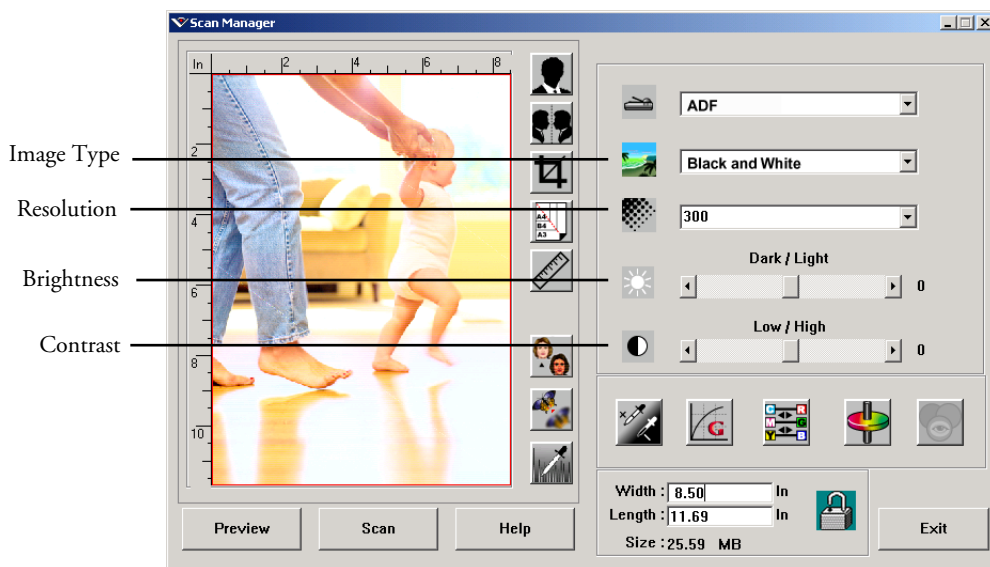

## IMAGE TYPE

From the **Image Type** drop-down list, select the appropriate image type for the item(s) you're scanning:

- **Black and White**—scans in black and white. The scanning pixels are all the same size and are either black or white. Use this setting for letters, memos, pen and ink drawings, and other black and white material. This setting produces the smallest file size for scanned items.
- **Halftone**—scans the image so it appears to consist of gray tones. A pop-up menu appears so you can choose one of the halftone options. Notice that the preview image changes as you select each option so you can see which one is best for scanning. Halftones produce simulated gray tones by using black and white pixels of different sizes and is often used to produce newspaper and magazine images. Use this setting for lower resolution black and white images. The halftone settings also produce small file sizes.



Halftone Example

- **8-Bit Gray**—scans the image using up to 256 true shades of gray. Use this setting to scan black and white photographs and other higher quality black and white images. You can also scan a color photo with this setting to turn its colors into gray shades. The file size is about one third the size of a color scan.
- **24-Bit Color**—scans the image in full color. Use this setting to scan color photographs and other color images. The file size is the largest of the image type options.
- **Enhanced bit-depths**—If you are using an imaging application other than PaperPort, the image type drop-down list will include 16-Bit Grayscale and 48-Bit Color. These image types are only available if the imaging application supports them. You will receive an error message if the application does not support the selected enhanced bit-depth.

---

**Note:** You can see the file size at the bottom of the Scan Manager.

---

## RESOLUTION

Resolution determines the amount of detail you can see in the scanned image. The resolution setting for a scan is in dots-per-inch (dpi). The higher the resolution, the finer the details, however, higher dpi settings also take longer to scan and produce larger files sizes. Usually the higher resolution settings are used for precision work, such as photographs or fine artwork.

- Click the **Resolution** drop-down list and select a resolution.

The resolution settings on your Strobe XP 450 scanner range from 100 dpi to 2400 dpi.

## BRIGHTNESS AND CONTRAST

Sometimes an item is scanned with the brightness and contrast set too light or too dark. For example, a note written with a light pencil may need to be scanned darker to improve legibility.

Brightness refers to the lightness or darkness of the image. Contrast is the range between the darkest and lightest portions of the image. The greater the contrast, the more the difference between the lighter and darker shades in the image.

- **Dark/Light slider**—adjusts the brightness of the scan. Drag the slider to the right or left to increase or decrease the brightness.
- **Low/High slider**—adjusts the contrast. Drag the slider to the right or left to increase or decrease the contrast.

## ADJUSTING THE OUTPUT SIZE

The output size is the width and height of the image after it is scanned. For example, if you plan to print the image on a piece of paper you can select the output size of 8.5 by 11.0 inches.

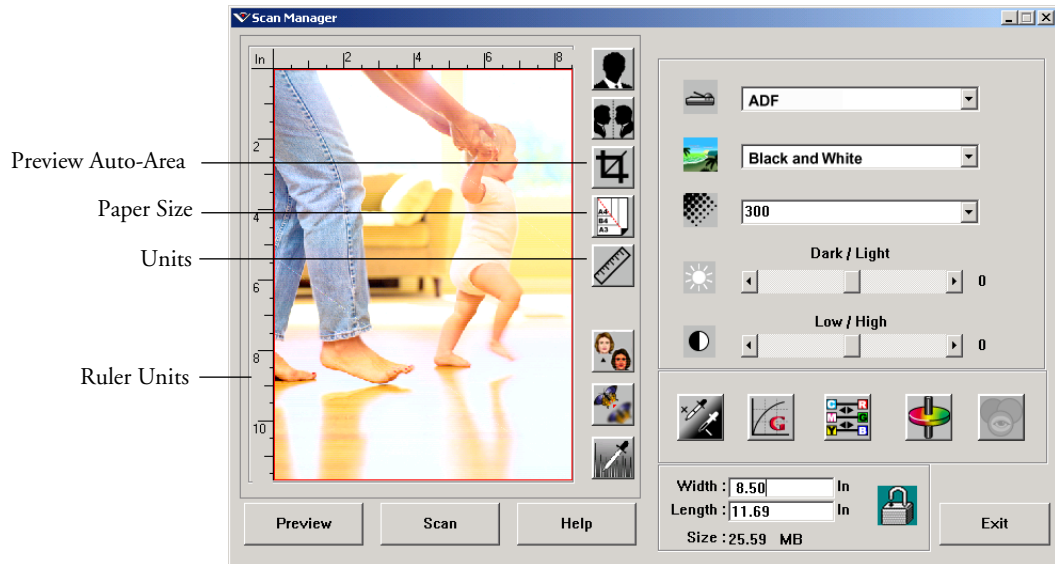

## PREVIEW AUTO-AREA

The item you're scanning may not fill the scanning area. In that case you can preview the item and use the Preview Auto-Area button to automatically set the size of the scanned image.

- Click the **Preview Auto-Area** button to let the Scan Manager automatically determine the size of the item being previewed.

For example, if you preview the scan of a small photo, the Scan Manager automatically determines that the scan area is only the edges of the photo.

You can manually adjust the scan area. For example, if you want the scan to include a border around the image, drag the edges of the scan area box.

## PAPER SIZE

If you know the size of the item(s) you're scanning, set the paper size. This automatically sets the scan size to the paper size.

- Click the **Paper Size** button and select the image's paper size from the list.

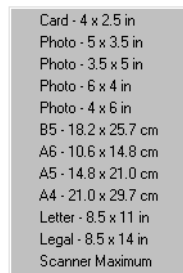

## UNITS

The ruler around the edges of the image area and the output dimensions can be displayed in inches, centimeters, or pixels.

- Click the **Units** button to select the units for the ruler. Clicking the button toggles through the three choices. The ruler and output dimensions change to the new units.

## SETTING THE SCAN AREA

You can manually adjust the output area to scan specific sections of an image. For example, if you're scanning a photograph and want to focus on one section, manually setting the output size removes the rest of the photograph from the final scanned image.

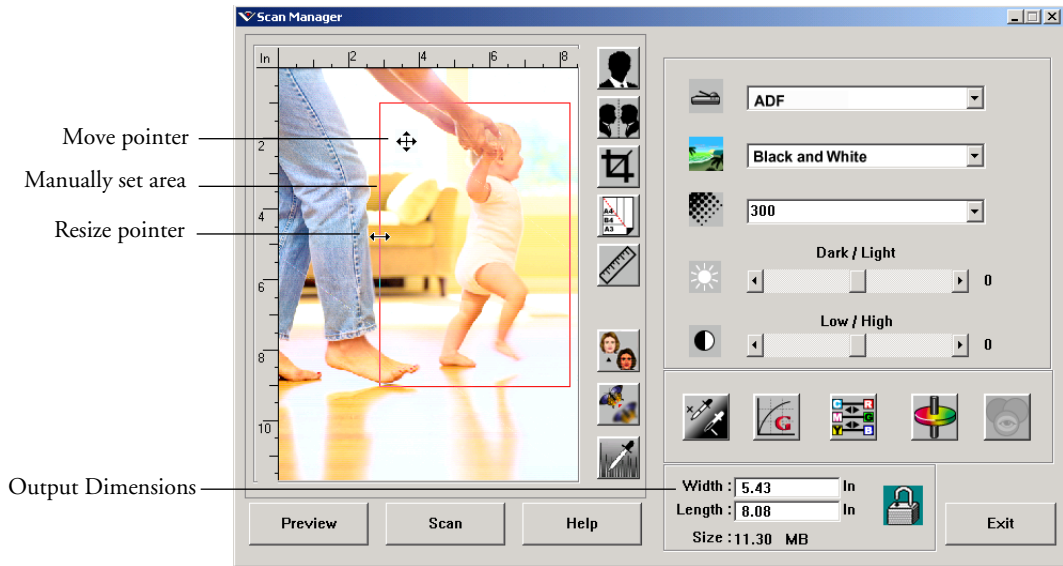

### To manually set an output area:

1. Put the mouse pointer on an edge of the scan area box so it becomes a resize pointer (two-headed arrow) and then drag to set a new size for the box.
2. To move the box, put the mouse pointer inside the box so the pointer becomes a four-headed arrow. Drag to move the box to a new position.
3. The output dimensions change to reflect the new scan area size.

Now, when you scan, only the area inside the scan area box is scanned to the PaperPort desktop.

---

**Note:** If you want to reset the scan area to the full size of the image again, click the **Preview Auto-Area** button.

---

Here's a sample of a manually selected output area:

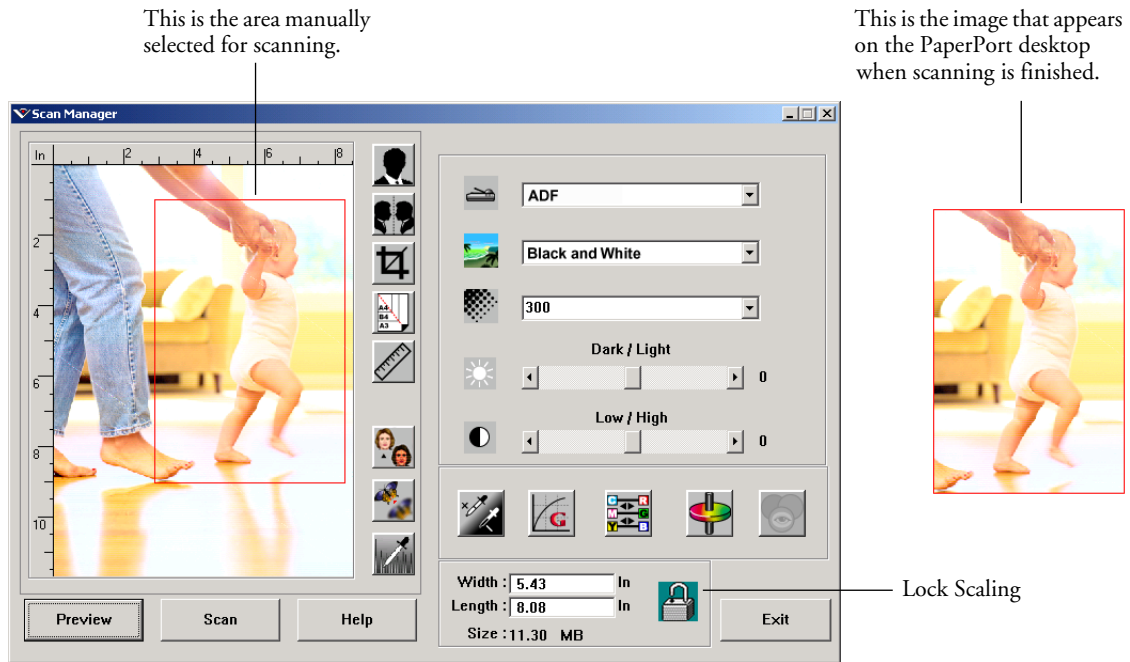

## MANUALLY SETTING THE WIDTH AND LENGTH

The output dimensions at the bottom of the Scan Manager show the Width and Length of the scan area. You can set the area by typing numbers into those boxes.

### To manually set the width and length:

1. Click in the **Width** or **Length** box and type a new dimension.  
The scan area box changes to reflect the new size.
2. To maintain the same width to length ratio, click the **Lock Scaling** icon next to the dimension.

With the Lock Scaling locked, when you type a new width or length, the other setting changes so the relative size of the scan area remains constant.

## REVERSING THE IMAGE

The Scan Manager has an Invert button and a Mirror button for reversing the scanned image.

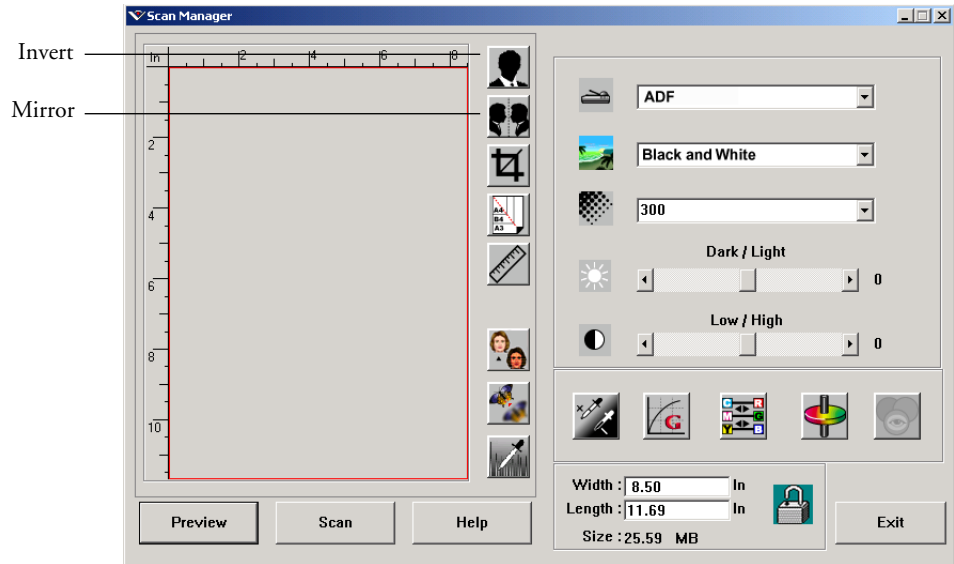

Invert reverses the black and whites or the colors of an image.

Mirroring flips the image 180 degrees.

- Click the **Invert** or **Mirror** button to see the image you want.

Original Image



Inverted Image



Mirrored Image

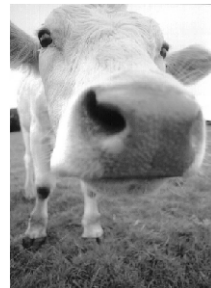

## ADJUSTING COLOR AND GRAY IMAGES

The Scan Manager has three buttons—Descreen, Sharpen, and Auto Level—for adjusting color and gray images. These buttons are available when the 24-Bit Color or 8-bit Gray Image Types are selected.

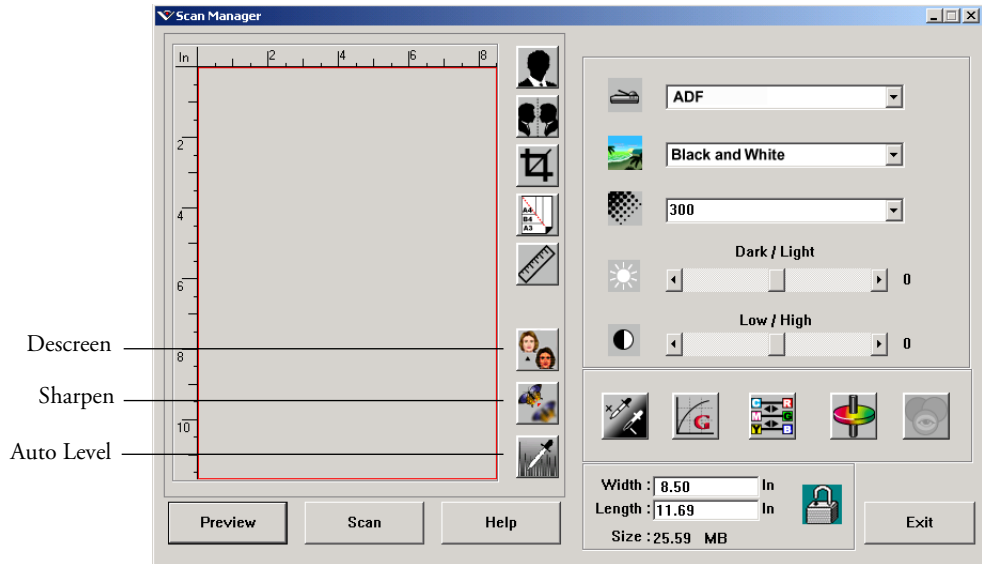

### DESCREEN IMAGE

Select this option when scanning a picture from a newspaper or magazine article, sales catalog, or other source that contains images with patterns or dots. Scans of patterns or dots sometimes have a distorted or wavy appearance. The scanner scans the item to compensate for the patterns and dots, and produces a clearer image. The scanning may slow down a bit when this option is selected. You don't need to select this option when scanning photographs.

Original Image



Descreened Image





**To descreen an image:**

1. Click the **Descreen** button.
2. Choose the appropriate option from the list.



Watch the preview image as you select various options to see which one is best for your final scanned image.

**SHARPEN IMAGE**

Sharpness determines the amount of blur in an image. Your scanner can sharpen an original blurred image by adjusting the blurry edges in sections of the image.

**To sharpen an image:**

1. Click the **Sharpen** button.
2. Choose the appropriate option from the list.

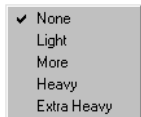

Original Image



Sharpened Image

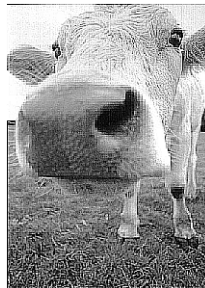

### AUTO LEVEL

Your scanner can analyze a color image to automatically determine the best settings to match the colors of the original image. Click this button to let the scanner automatically adjust the color settings.

Original Image

AutoLevelAdjusted



### ADJUSTING COLOR SETTINGS

The buttons for manually adjusting a preview image's color settings offer several advanced color options. The availability of each option is dependent upon the selected Image Type for the image.

The screenshot shows the Scan Manager software interface. On the left is a preview window with a ruler. On the right is a control panel with various settings. Labels with lines pointing to specific controls are as follows:

- Highlight/Shadow Levels:** Points to the 'Dark / Light' slider.
- Curves:** Points to the 'Curves' icon in the bottom toolbar.
- Color Balance:** Points to the 'Color Balance' icon in the bottom toolbar.
- Hue/Saturation/Lightness:** Points to the 'Hue/Saturation/Lightness' icon in the bottom toolbar.
- Color Drop-out:** Points to the 'Color Drop-out' icon in the bottom toolbar.

Other visible controls in the interface include:

- ADF (Automatic Document Feeder) dropdown menu.
- Black and White dropdown menu.
- Resolution dropdown menu set to 300.
- Dark / Light slider set to 0.
- Low / High slider set to 0.
- Width: 8.50 In, Length: 11.69 In, Size: 25.59 MB.
- Buttons for Preview, Scan, Help, and Exit.

## HIGHLIGHT/SHADOW LEVELS

Images have light and dark areas. The highlight is the lightest spot on an image; shadow is the darkest spot. The range of colors between the highlight and shadow determines the range of colors of the image. Use the Highlight/Shadow Levels to extend the original range of colors between the highlight and shadow to reveal more details in the midrange colors.

### To adjust the highlight and shadow levels:

1. Click the **Highlight/Shadow** button.

The dialog box shows a histogram of the saturation, gamma, and hue (S, G, H) of the range of colors for the highlight and shadow.

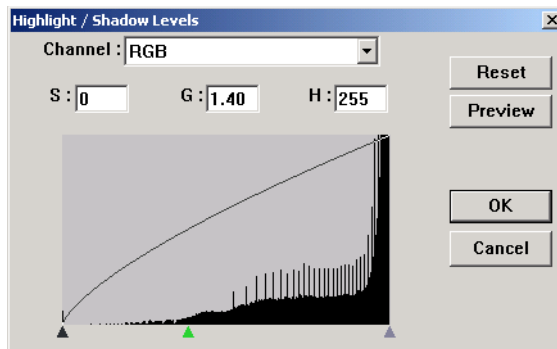

Saturation is the strength or purity of a color, gamma controls the brightness of the midtones of the color, and hue is the color your eyes see as reflected from the image. The gamma setting in this dialog box is in conjunction with the hue and saturation but you can also set gamma by itself for an image. See the section “Curves,” below for more information

2. From the Channel drop-down list, choose **RGB** to adjust all the channels together, or choose a single channel if available.
3. Enter new settings in the boxes for the three levels, or drag the small triangles at the bottom of the histogram.

The histogram changes to show the new levels.

4. Click **Preview** to see the effect of the changes on the preview image.
5. Click **Reset** to reset the levels to their original values.
6. Click **OK** when the levels are what you want.

## CURVES

Like the Highlight/Shadow levels, the Curves feature also adjusts the range of midtone colors on an image. However, with the Curves feature you can set the gamma individually to adjust midtone levels without losing details from the lightest or darkest areas.

### To adjust the gamma curve:

1. Click the **Curves** button.

The dialog box that opens shows a plot of the gamma. The gamma of the original image is represented by a straight line from the lower left to upper right corners. Changing the straight line to a curve changes the gamma setting for the midtones on the original image.

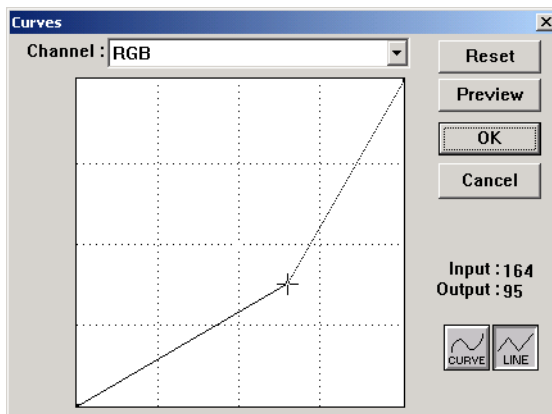

2. From the Channel drop-down list, choose **RGB** to adjust the gamma of all the channels, or choose a single channel if available.

3. Drag the line up or down to set a new gamma.

The input and output values represent values on the horizontal and vertical axes for the new gamma setting. Click the **Curve** or **Line** button to see the display as a smooth curve or a line. You can drag the line at multiple points.

4. Click **Preview** to see the effect of the changes on the preview image.
5. Click **Reset** to reset the levels to their original values.
6. Click **OK** when the levels are what you want.

## COLOR BALANCE

The color balance refers to the relative amounts of the three primary colors in an image. By adjusting the color balance you can sometimes compensate for an image with too much or too little of a color.

### To adjust the color balance:

1. Click the **Color Balance** button.

The settings in the dialog box are initially set to zero for each of the colors, indicating no change to the original image's color balance.

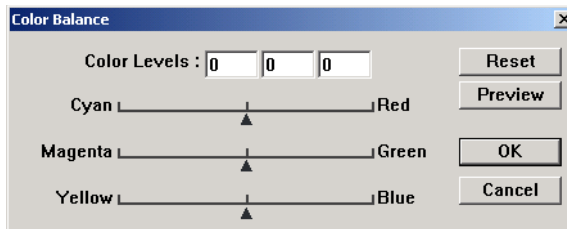

2. Type a number in one or more of the **Color Levels** boxes to set a new color level, or drag the triangles to the left or right.

Each color is paired with its complementary color, so as you drag a triangle you are increasing a color while decreasing its complementary color.

3. Click **Preview** to see the effect of the changes on the preview image.

4. Click **Reset** to reset the levels to their original values.
5. Click **OK** when the levels are what you want.

### HUE/SATURATION/LIGHTNESS

Hue is the color your eyes see as reflected from the image, saturation is the strength or purity of a color and determines whether a color is pale or rich, and lightness is the intensity of the color.

#### To adjust the hue/saturation/lightness:

1. Click the **Hue/Saturation/Lightness** button.

The settings in the dialog box are initially set to zero, indicating no change to the original image's hue, saturation, or lightness.

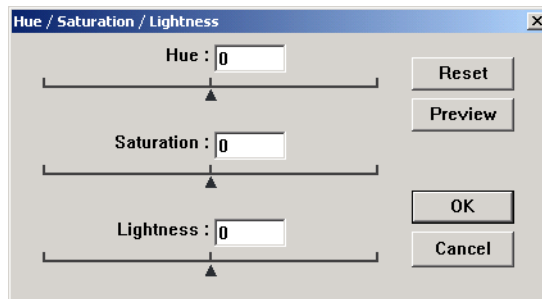

2. Type a number in one or more of the color boxes to set a new level, or drag the triangles to the left or right.
3. Click **Preview** to see the effect of the changes on the preview image.
4. Click **Reset** to reset the levels to their original values.
5. Click **OK** when the levels are what you want.

## COLOR DROP-OUT

Color drop-out is the ability of your scanner to automatically remove one color from a scanned item. For example, if you are scanning a letter with a red watermark, you can choose to drop-out the color red (the R Channel) so the scanned letter just shows the text and not the red watermark.

Color drop-out applies when you select the scanning image types of Black and White, Halftone, 8-Bit Gray or 16-Bit Grayscale. It does not apply to the image types of 24-Bit Color or 48-Bit Color.

Here are some examples of color drop-out:

The original with black text on a blue background

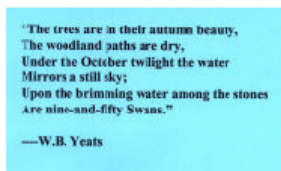

The scanned item with the B Channel (Blue) dropped out

"The trees are in their autumn beauty,  
The woodland paths are dry,  
Under the October twilight the water  
Mirrors a still sky;  
Upon the brimming water among the stones  
Are nine-and-fifty Swans."  
—W.B. Yeats

The original with a red watermark over black text

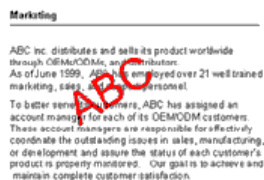

The scanned item with the R Channel (Red) dropped out

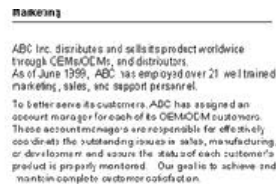

### To drop the color out of a black and white, or grayscale image:

1. From the Image Type list, choose **Black and White**, **Halftone**, **8-Bit Gray**, or **16-Bit Grayscale**.
2. Click the Color Drop-out icon.

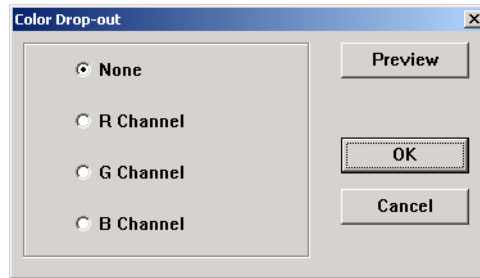

3. On the Color Drop-out dialog box, choose a color to drop out.
4. Click **OK**.

Now when you scan the black and white or gray item, the selected color is removed.

## ADJUSTING THE SCANNER'S POWER SAVING TIME

Your scanner has a built-in power saving feature that is set to power down after 45 minutes of idle time. You can change the time before the scanner powers down, from 15 to a maximum of 180 minutes.

### To adjust the power down time:

1. Right-click the Visioneer icon on the top-left corner of the Scan Manager desktop and select **Set Power Saving** from the menu.
2. On the Set Power Saving Time dialog box, enter a value from 15 to 180 minutes.
3. Click **OK** to save the change and close the dialog box.



## SCANNING FROM WINDOWS ME OR XP

If your computer is running the Windows Me or XP operating system, you have a choice of scanning using the TWAIN-compliant Visioneer Scan Manager software as just described (see “Scanning from Windows 98, Me, 2000, or XP” on page 24) or scanning using the Microsoft Windows Image Application (WIA) standard as described below.

---

**Note:** The screen captures in this section show the WIA-standard screens as they appear in the Windows XP operating system. If you are using Windows Me, the screens will look slightly different, but will function in the same manner.

---

### To scan an item:

1. On the Windows taskbar, click **Start**, point to **All Programs**, point to **ScanSoft PaperPort 9.0**, and then click **PaperPort**.

The PaperPort desktop opens.



2. Click the **Scan** icon on the PaperPort command bar.

The Folders pane is replaced by the Scan pane.

Scan pane

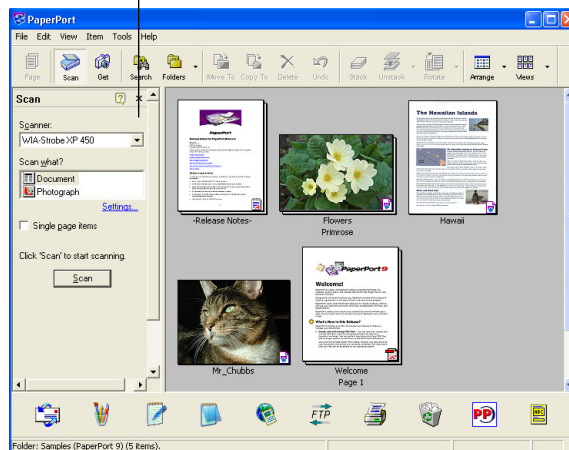

3. From the Scanner drop-down list, select **WIA-Strobe XP 450**.

4. In the “Scan what?” section, choose to scan a **Document** or **Photograph**.
5. Click **Settings** to view and change the format for the scanned item’s file name and the file type. The default file type for documents is .pdf and for photographs is .jpg.
6. Use the **Single page items** check box as follows:
  - When the check box is selected, all pages in the document feeder are scanned and placed in a stack on the PaperPort desktop.
  - When the check box is not selected, all pages in the document feeder are scanned, but not placed on the PaperPort desktop until you indicate the scanning job is finished.
7. Click the **Scan** button in the Scan pane.

The Scan using Strobe XP 450 window opens. Use this window to select scanning options and start the scanner.

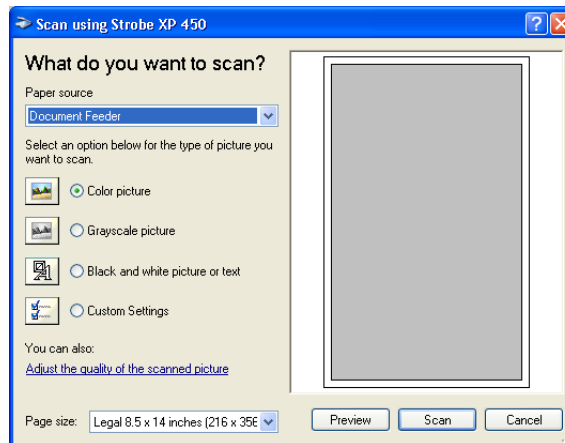

8. Make sure the Paper source value is set to **Document Feeder**.
9. Click the button most appropriate for the item you’re scanning.
10. Select a paper size from the Page Size drop-down list.
11. Click **Preview** to preview the image before scanning.  
The image is displayed on the right side of the window.

---

**Note:** If you preview when scanning a stack of documents, the first page of the stack feeds through the ADF for the preview. After adjusting the scanner settings, replace that page on the stack so it is scanned with the rest of the pages.

---

12. Adjust settings of the previewed image as desired:
  - Change the button selection for the type of image.
  - Adjust the custom settings; refer to the next section, “Fine Tuning Your Scans”.
  - Change the size of the scanned image. To do this, click and hold the mouse pointer over one of the four sizing-boxes on the corners of the previewed image. Then drag the box to increase or decrease the size of the image.
13. Preview the image again. When you are satisfied with the image, click the **Scan** button.

If the **Single page items** check box is selected on the Scan pane, the scanned item appears as a thumbnail on the PaperPort desktop.
14. If the **Single page items** check box is not selected, thumbnails do not appear until you indicate the scanning job is finished.
  - On the PaperPort - Scan message box, click **Done**.

---

**Note:** Refer to “The Single Page Items Check Box” on page 27.

---

## FINE TUNING YOUR SCANS

You can select new settings before you scan an item to fine tune exactly how you want to scan a particular item.

### To select the scanner settings before you scan:

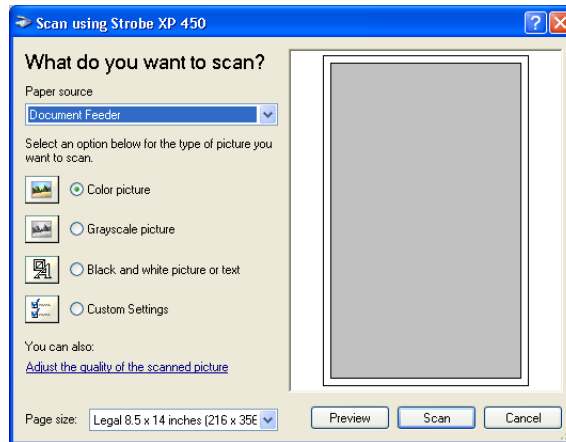

1. On the Scan using Strobe XP 450 window, click **Adjust the quality of the scanned picture.**

The Advanced Properties dialog box opens.

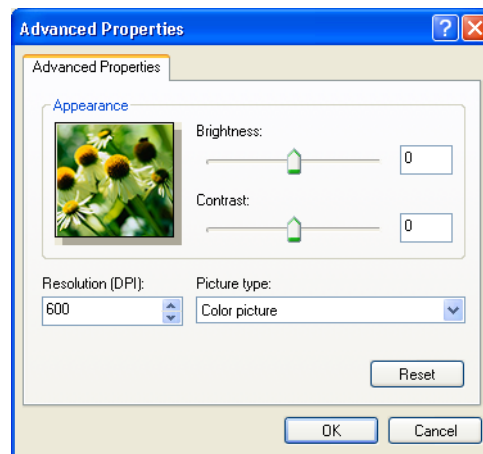

2. Select the options for scanning.

**Brightness and Contrast**—Drag the sliders to the right or left to adjust the brightness and contrast of the scanned image. The Contrast setting does not apply to the setting **Black and White picture or text**.

**Resolution (DPI)**—Click the drop-down list and choose the dots per inch (dpi) of the resolution. The maximum resolution is 600 dpi; the minimum is 50 dpi. The higher the dpi setting, the sharper and clearer the scanned image. However, higher dpi settings take longer to scan and produce larger files for the scanned images.

**Picture type**—Click the drop-down menu and choose the most appropriate type for the item you're scanning.

3. Click **OK**.

The Custom Settings button is now set to scan with the options you selected.

If you want to reset the settings and start over, click **Reset**.

# Maintenance

This chapter contains information on maintenance, troubleshooting, uninstalling, scanner specifications, and spare parts.

## CLEANING THE AUTOMATIC DOCUMENT FEEDER

You may need to clean the ADF feed mechanism if your documents do not feed easily into the ADF, or several feed in at the same time.

### To clean the ADF:

1. Wet a cotton swab with some isopropyl alcohol (95%).
2. Press the ADF cover release on the top left of the scanner body to open the automatic document feeder cover.

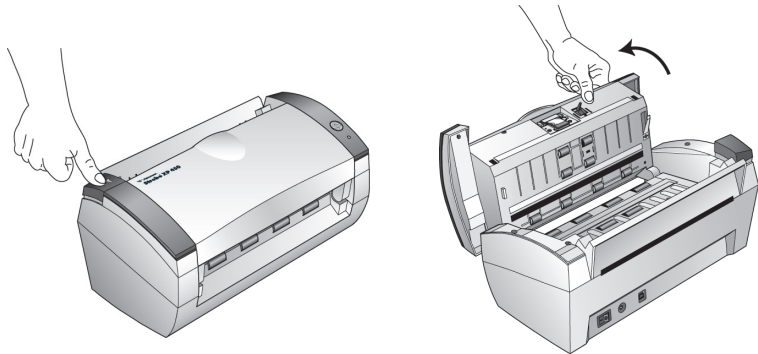

3. Wipe the feed roller from side to side. Rotate the roller to clean its entire surface.
4. Wipe the pad from top to bottom. Be careful not to snag the swab on the springs on either side of the pad.
5. Close the cover when you're finished.

## CLEARING PAPER JAMS

If your scanner stops scanning due to a paper jam in the Automatic Document Feeder, a warning dialog box opens after a few moments.



### To clear a paper jam:

1. Press the ADF cover release on the top-left of the scanner body to open the automatic document feeder cover.

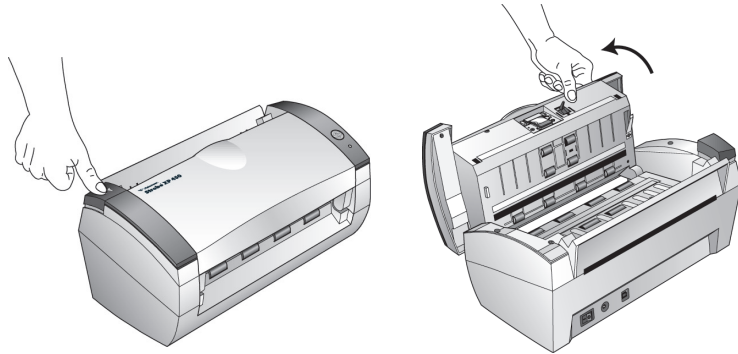

2. Remove the jammed paper and close the cover.

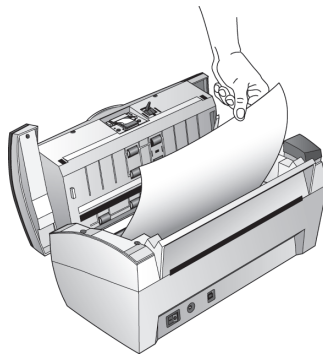

To reduce the number of paper jams, smooth and straighten paper before scanning and adjust the guides to the paper size.

## REPLACING THE ADF PAD ASSEMBLY

The ADF pad spring may begin to wear out after 150,000 scanned pages. Problems with documents feeding into the ADF is an indication that the pad spring may be wearing out.

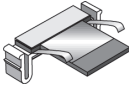

See the “Visioneer Strobe XP 450 Scanner Parts List” on page 58 for ordering information.

### To replace the ADF Pad assembly:

1. Press the ADF cover release on the top left of the scanner body to open the automatic document feeder cover.

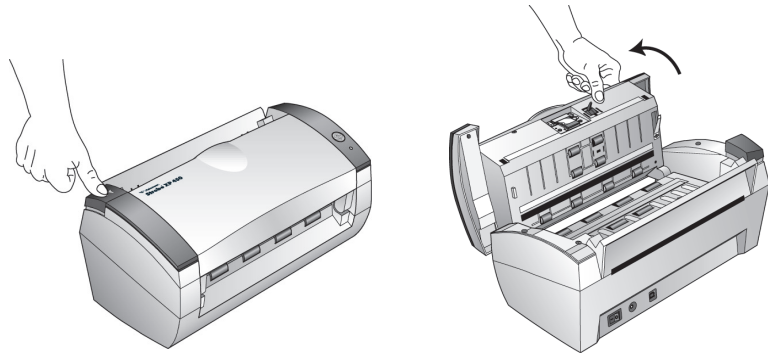

2. Squeeze the plastic clamps that hold the pad assembly in place and lift the pad up and out

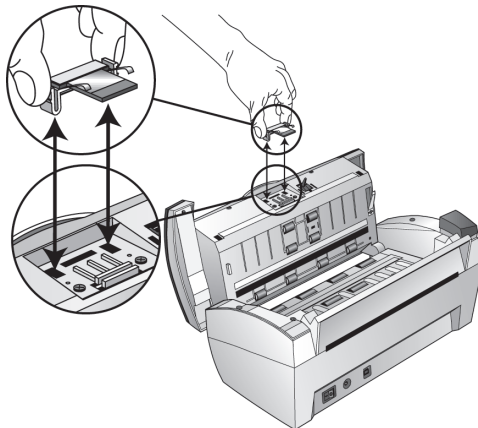

3. Reverse the procedure to replace the new pad into its slots.



## TROUBLESHOOTING

In addition to the troubleshooting information contained in this section, please see the Readme file on your installation CD. The Readme file contains additional information that may help you diagnose problems with the scanner.

If you try the troubleshooting procedures described in this section and in the Readme file, and the scanner still has problems, you may have a malfunctioning scanner. Refer to the technical support card that you received with your scanner. Also visit our web site at [www.visioneer.com](http://www.visioneer.com) for additional technical information.

### **Problem: The scanner won't scan. What's wrong?**

Check for one of these possible problems:

- **Are the cables loose or not plugged in securely?** Inspect the cable connections. Make sure the cables are plugged in securely.
- **Is the scanner's status light on?** Turn on the scanner's power. If the status light doesn't come on, plug the power supply into another electrical outlet.
- **Did you restart the computer after installing the software?** If you didn't restart the computer, it may not have loaded all of the software files. Try restarting your computer.
- **Did you plug the scanner into a USB hub?** If you're using a USB hub to connect the scanner, the hub must have its own power supply. If the hub does not have its own power supply, plug the scanner into a USB port on the computer.
- **Did you select another scanning source in the PaperPort Scan Pane?** If you use multiple devices with your computer, you may have selected another source for images. Start the PaperPort software and click the **Scan** icon, and then make sure **Strobe XP 450** is selected as the scanner.

**Problem: During installation I got the error message: PaperPort Installation is not complete. What do I do?**

The installation procedure was not successful. You need to reinstall the PaperPort software.

**Problem: I got the error message: PaperPort cannot allocate enough memory to perform internal critical operations. What do I do?**

Close any other active applications so that additional memory is available. If you click Continue, PaperPort moves the file to the PaperPort data directory and renames the file with the prefix "bad". This allows you to recover the file later.

To recover the file, you can import it into PaperPort by using the Import command in the File menu.

**Problem: How do I uninstall PaperPort?**

See the next section. Uninstalling does not delete your scanned items, and they remain in the PaperPort Data folder.

**Problem: What do the different status light conditions mean?**

The status light indicates the current state of the scanner. Descriptions of the most common patterns are listed below. Contact Visioneer Technical Support if you experience a different blinking pattern.

- **Blinking green:** indicates the scanner is preparing to scan.
- **Steady green:** indicates the scanner is ready to scan.
- **Blinking red, 1 long + 13 short blinks:** indicates the scanner cover is open.

## UNINSTALLING YOUR SCANNER

To uninstall the Visioneer Strobe XP 450 scanner, remove the scanner software first, and then remove PaperPort, or other scanner software.

### STEP 1: UNINSTALLING THE VISIONEER ONE TOUCH SOFTWARE

1. On the Windows taskbar, click **Start**, point to **Settings**, and then click **Control Panel**.
2. Double-click the **Add/Remove Programs** icon.
  - Windows 98, 98SE, or ME: The Add/Remove Programs Properties window opens. Select the Install/Uninstall tab.
  - Windows 2000 or XP: The Add or Remove Programs window opens. Make sure the Change or Remove option is selected.
3. From the list of programs, select **Visioneer Strobe XP 450**.
  - Windows 98, 98SE, and ME: Click the **Add/Remove** button.
  - Windows 2000 or XP: Click the **Change/Remove** button.
4. On the Select Uninstall Method window, make sure the **Automatic** option is selected, and then click **Next**.

---

**Important:** The Automatic option is selected by default and is recommended by Visioneer. The other options are for advanced users.

---

5. On the Perform Uninstall window, click **Finish**.

The Visioneer OneTouch software is removed from your computer.
6. If the Remove Shared Components window opens, Visioneer recommends selecting **No to All**.
7. Unplug the USB cable from your computer and scanner.
8. Close all open windows and restart your computer.

## STEP 2: UNINSTALLING THE PAPERPORT SOFTWARE

### To uninstall PaperPort 9.0 from Windows 98SE or ME:

1. On the Windows taskbar, click **Start**, point to **Settings**, and then click **Control Panel**.
2. Double-click the **Add/Remove Programs** icon.
3. On the Add/Remove Programs Properties window, select the **Install/Uninstall** tab.
4. Select **PaperPort 9.0** and click **Remove**.
5. On the Welcome window, click **Next**.
6. On the Program Maintenance window, select the **Remove** option, and then click **Next**.
7. On the Remove the Program window, select the **Remove files** option, and then click **Remove**.

The PaperPort software is removed.

8. On the Uninstall Completed window, click **Finish**.
9. Close all open windows and restart your computer.

### To uninstall PaperPort 9.0 from Windows 2000 or XP:

1. On the Windows taskbar, click **Start**, point to **Settings**, and then click **Control Panel**.
2. Click the **Add or Remove Programs** icon.

The Add or Remove Programs window opens.

3. Select **PaperPort 9.0** and click **Remove**.
4. A message window opens, asking if you are sure you want to remove PaperPort 9.0 from your computer. Click **Yes**.

The PaperPort software is removed.



5. Close all open windows and restart your computer.

## VISIONEER STROBE XP 450 SCANNER SPECIFICATIONS

<b>Optical resolution</b>	600 x 1200 dpi
<b>Bit depth</b>	48-bit color
<b>Maximum item size</b>	8.5" x 14"
<b>Minimum item sizes</b>	3.5" x 2" (automatic document feeder) 2.5" x 2" (front feed)
<b>Scan method</b>	Automatic document feeder (ADF)
<b>ADF specifications</b>	
Scanning Speed	Up to 22 pages per minute @ 200 dpi B&W
Capacity	50 sheets
Paper Thickness	16 - 28 lbs. (0.002" - 0.006")
<b>Light source</b>	Cold cathode fluorescent lamp
<b>Interface</b>	USB 2.0
<b>Scanner dimensions</b>	
Height	12.5 inches (31.75 cm)
Width	13.25 inches (33.66 cm)
Length	17 inches (43.18 cm)
<b>Weight</b>	8.6 pounds (3.91 kg)
<b>Operating temperature</b>	50°–104° F (5°–35° C without condensation)
<b>Relative humidity</b>	40%–70% (@35° C without condensation)
<b>Power supply</b>	
Input voltage/frequency	100 - 240 Vac, 47 - 63 Hz
Output voltage/watt	24 V DC, 20.16 watt maximum
<b>Power consumption</b>	< = 30 Watts
<b>Safety and agency certifications</b>	UL, ULc, FCC Class B, VCCI Class B, CE
<b>Hardware warranty</b>	One-year limited warranty upon registration of the scanner

## VISIONEER STROBE XP 450 SCANNER PARTS LIST

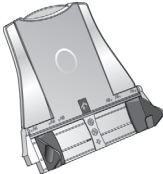
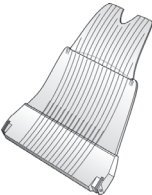
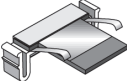
Please use the following part names and numbers when ordering replacements for your scanner.

	<b>Part Name</b>	<b>Part Number</b>
	Paper Guide	57-0101-000
	Output Tray	57-0102-000
	ADF Pad	57-0100-000
	AC Power Cord	35-0071-000
	Power Supply	37-0064-000

**INDEX****Numerics**

24-bit color 29, 43

8-bit gray 29, 43

**A**

adjust image 28

AutoCrop

cropping images 18

automatic color adjustment 38

AutoScan 11

configuring 13

**B**

bit depth 57

black and white 29

brightness 30

brightness slider 30

**C**

CD

other software 10

CD-ROM drive 3

color adjustment 36

automatic 38

manual setting 38

color balance 41

color drop-out 43

components 2

computer specifications 3

Configuration dialog box 13

configuring AutoScan 13

editing 19

new configuration 16

new settings 15

contrast 14, 30

contrast slider 30

cropping 18

**D**

DeScreen 18

descreen image 36

destination application

OCR 15

distorted image 36

documentation 4

dots-per-inch 30

dpi 30

**G**

gamma 39

manual setting 40

gamma setting 18

**H**

halftone 29

help 4

highlight level 39, 40

hue 39, 42

**I**

image

adjust color 36, 38

color balance 41

descreen 36

highlights 39, 40

invert 35

mirror 35

shadows 39, 40

sharpen 37

image adjustment 28

image size 31

image type 29

installation 5

**L**

length and width

manual setting 34

lightness 42

lock scaling icon 34

**M**

magazine article 36

monitor 3

**N**

newspaper article 36

**O**

on/off switch 7  
output size 31, 33

**P**

paper guide 5  
paper size 32  
PaperPort 22  
    desktop 24  
    Scan pane 24  
    scanning with Windows Me or XP 45  
PaperPort desktop  
    thumbnail 27  
patterns on picture 36  
preferences  
    setting for AutoScan 20  
    tab 20  
preview auto-area 31

**R**

resolution 30  
reverse image 35  
RGB 39, 40  
ruler units 32

**S**

saturation 39, 42  
scan  
    file name 27  
    multiple pages 27  
    PaperPort desktop 27  
    preview 26  
    small item 31  
scan area  
    automatic setting 31

    manual setting 33

Scan Manager  
    scan options 28

scanner  
    components 2  
    connecting 6  
    troubleshooting 53  
    uninstall 55

scanning  
    AutoScan 11  
    from PaperPort 22  
        Windows 98, Me, 2000, or XP 24

setup 5  
shadow level 39, 40  
sharpen image 37  
specifications  
    computer 3  
    monitor 3  
status light 7, 53  
system requirements 3

**T**

thumbnail 27  
troubleshooting 53  
Twain standard 22

**U**

uninstall 55  
units 32  
USB port 9

**W**

watermark, remove 43  
wavy appearance 36  
WIA standard 22  
Windows Me or XP  
    scanning in PaperPort 45



## Free Manuals Download Website

<http://myh66.com>

<http://usermanuals.us>

<http://www.somanuals.com>

<http://www.4manuals.cc>

<http://www.manual-lib.com>

<http://www.404manual.com>

<http://www.luxmanual.com>

<http://aubethermostatmanual.com>

Golf course search by state

<http://golfingnear.com>

Email search by domain

<http://emailbydomain.com>

Auto manuals search

<http://auto.somanuals.com>

TV manuals search

<http://tv.somanuals.com>