



Visioneer® Strobe XP 470
USB Scanner
User's Guide



visioneer



for Windows

Visioneer Strobe XP 470 USB Scanner User's Guide

FOR WINDOWS



COPYRIGHT INFORMATION

Copyright © 2005 Visioneer, Inc.

Reproduction, adaptation, or translation without prior written permission is prohibited, except as allowed under the copyright laws.

The Visioneer brand name and logo are registered trademarks of Visioneer, Inc. The PaperPort brand name and logo are registered trademarks of ScanSoft, Inc.

This product is covered by one or more of the following patents: 6,459,506 6,054,707 6,275,309 5,818,976 5,499,108 5,517,332.

Microsoft is a U.S. registered trademark of Microsoft Corporation. Windows is a trademark of Microsoft Corporation. ZyINDEX is a registered trademark of ZyLAB International, Inc. ZyINDEX toolkit portions, Copyright © 1990-1998, ZyLAB International, Inc. All Rights Reserved. All other products mentioned herein may be trademarks of their respective companies.

Information is subject to change without notice and does not represent a commitment on the part of Visioneer. The software described is furnished under a licensing agreement. The software may be used or copied only in accordance with the terms of such an agreement. It is against the law to copy the software on any medium except as specifically allowed in the licensing agreement. No part of this document may be reproduced or transmitted in any form or by any means, electronic or mechanical, including photocopying, recording, or information storage and retrieval systems, or translated to another language, for any purpose other than the licensee's personal use and as specifically allowed in the licensing agreement, without the express written permission of Visioneer.

Part Number: 05-0687-000

Restricted Rights Legend

Use, duplication, or disclosure is subject to restrictions as set forth in contract subdivision (c)(1)(ii) of the Rights in Technical Data and Computer Software Clause 52.227-FAR14. Material scanned by this product may be protected by governmental laws and other regulations, such as copyright laws. The customer is solely responsible for complying with all such laws and regulations.

Technical Support

Visit Visioneer's web site at www.visioneer.com for technical support including help during installation, driver updates, spare parts, and documentation.

FCC Radio Frequency Interference Statement

This equipment has been tested and found to comply with the limits for the class B digital device, pursuant to part 15 of the FCC Rules. These limits are designed to provide reasonable protection against interference in a residential installation. This equipment generates, uses and can radiate radio frequency energy and if not installed, and used in accordance with the instructions, may cause harmful interference to radio communications. However, there is no guarantee that interference will not occur in a particular installation. If this equipment does cause harmful interference to radio or television reception, which can be determined by turning the equipment off and on, the user is encouraged to try and correct the interference by one or more of the following measures:

- Reorient or relocate the receiving antenna.
- Increase the separation between the equipment and receiver.
- Connect the equipment into an outlet on a circuit different from that to which the receiver is connected.
- Consult the dealer or an experienced radio/TV technician for help.

This equipment has been certified to comply with the limits for a class B computing device, pursuant to FCC Rules. In order to maintain compliance with FCC regulations, shielded cables must be used with this equipment. Operation with non-approved equipment or unshielded cables is likely to result in interference to radio and TV reception. The user is cautioned that changes and modifications made to the equipment without the approval of manufacturer could void the user's authority to operate this equipment.

This device complies with part 15 of the FCC Rules. Operation is subject to the following two conditions: (1) This device may not cause harmful interference, and (2) this device must accept any interference received, including interference that may cause undesired operation.

TABLE OF CONTENTS

Welcome	1
What's in the Box	1
The Visioneer Strobe XP 470 Scanner	2
What You Need	4
Documentation	4
Installation	5
Before You Begin	5
Step 1: Assemble the Scanner	6
Step 2: Install the Software	8
To Install Another Driver	15
Step 3: Connect and Power On the Scanner	16
Step 4: Connect the USB Cable	17
Install OmniPage 12 and Additional Software	21
Register Your Scanner	24
Scanning	25
Load and Scan Documents	25
Check the Scan Settings Before Scanning	28
Scan from the OneTouch Button Panel	30
Using the OneTouch Button Panel	31
Scanning from Other Software	33
The Default OneTouch Settings on Your Scanner	34
Configuring the OneTouch Buttons	35
About the OneTouch Properties Window	36
Selecting New Settings for a Button	38
Setting Destination Application Properties	40
Selecting Page Format Options	49
Renaming a OneTouch Button	54
Selecting Options for a Button	55

Creating a New Scan Configuration	58
Editing or Deleting Scan Configurations	67
Configuring Before Scanning	68
Scanning with Optical Character Recognition (OCR)	70
Using OmniPage OCR Options	71
Scanning with sPDF or nPDF and Searching for Text	79
Scan and Burn to a CD	82
Scanning with Event Forwarding	84
Creating an HTML Web Page from Your Scanned Documents	86
Transferring Scanned Documents to Storage	89
Checking the Hardware and Setting the Lamp Power Save Mode	92
Scanning from PaperPort	95
Scanning from the Basic Interface or Advanced Interface	96
Scanning from the Basic Interface	101
Scanning from the Advanced Interface	105
Adjusting the Image with the Advanced Interface	108
Adjusting the Brightness and Contrast	112
Adjusting Gamma, Saturation, and Color Hue	113
Adjusting Input Size	114
The Ruler Units	116
The Scan Info Box	116
Creating a New Advanced Interface Profile	117
Display the Device Configuration	118
Scanning with the Windows Image Acquisition	119
Maintenance	124
Cleaning the Automatic Document Feeder	124
Clearing Paper Jams	125
Replacing the ADF Pad Assembly	126

Troubleshooting	127
Status Light Troubleshooting Codes	129
Uninstalling Your Scanner	131
Step 1: Uninstalling the Scanner and OneTouch Software ...	131
Step 2: Uninstalling the PaperPort Software	132
Visioneer Strobe XP 470 Scanner Specifications	134
Visioneer Strobe XP 470 Scanner Parts List	135
Index	137

WELCOME

Congratulations on purchasing your Visioneer Strobe XP 470 USB scanner. With your scanner you can quickly scan single-sided or double-sided stacks of color and black-and-white documents and place their images on your computer.

WHAT'S IN THE BOX

Before proceeding, check the contents of the box. If items are missing or damaged, contact the dealer where you purchased the scanner.

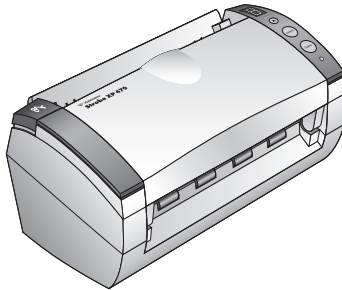

Visioneer Strobe XP 470 USB Scanner

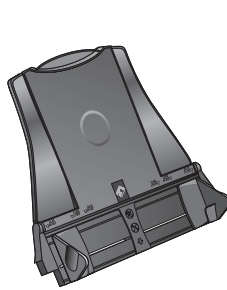

Paper Guide

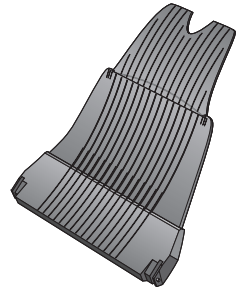

Output Tray



USB Cable

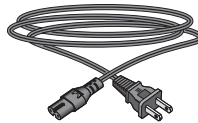

Power Cord



Power Supply

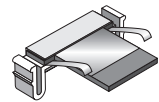

Replacement ADF Pad



Two CDs
Disc 1 and Disc 2



User's Guide



Buttons
Label

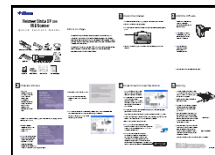

Quick Install Guide and Technical
Support Card



THE VISIONEER STROBE XP 470 SCANNER

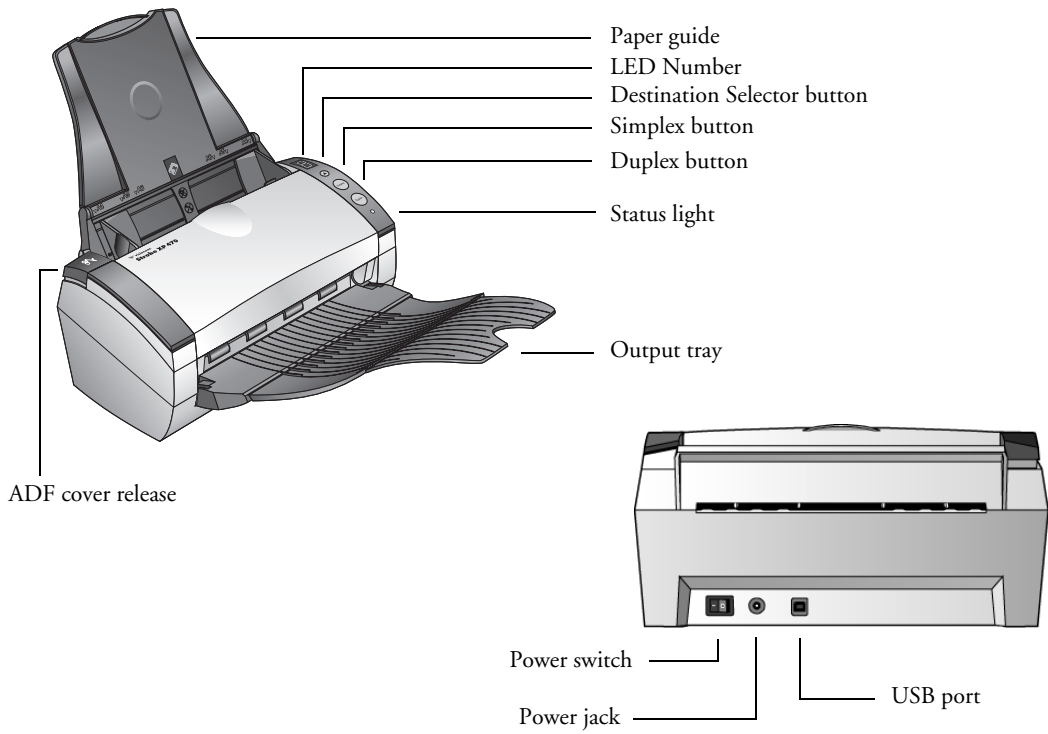

Paper guide—Holds documents in place. Adjusts to fit the document width.

LED Number—Shows the current scan setting for the Simplex and Duplex scanning buttons. A scan setting includes resolution, file type, brightness, color or black and white, destination, and so on.

Destination Selector button—Selects the scan setting for the Simplex and Duplex buttons. Press to cycle through the nine settings.

Simplex button—Press to scan a one-sided document.

Duplex button—Press to scan a two-sided document.

Status light—Shows the scanner's status. A rapidly flashing green light indicates the scanner is preparing to scan. A steady green light indicates the scanner is available to scan. Refer to the Troubleshooting section for additional details.

Output tray—Holds documents after scanning through the automatic document feeder (ADF).

ADF cover release—Opens the cover on the ADF.

Power switch—On/Off power switch.

Power jack—Connects the power cord to the scanner.

Universal Serial Bus (USB) port—Connects the scanner to the computer.

WHAT YOU NEED

An IBM-compatible PC with:

- A CD-ROM drive
- An available Universal Serial Bus (USB) port
- A Pentium II (or higher) processor or equivalent
- Microsoft Windows operating system: 2000 (Service Pack 4), Me, or XP (Service Pack 1 and 2)
- Available megabytes (MB) of internal memory (RAM):
 - 128 MB for Windows 2000 or Me
 - 256 MB for Windows XP
- 200 MB minimum of free hard disk space

A VGA Monitor

Recommended settings for your monitor are as many colors as possible—High Color (16-bit), True Color (24-bit or 32-bit). Set the resolution to at least 800 by 600 pixels.

To set your monitor's colors and resolution, open the Windows Control Panel, double-click Display, and then click the Settings tab.

DOCUMENTATION

Your scanner is delivered with the following documentation:

- Quick Install Guide—Abbreviated installation instructions.
- Visioneer Strobe XP 470 Scanner User's Guide—Detailed installation, scanning, configuration, and maintenance information.
- ScanSoft PaperPort User's Guide—On the Installation CD; contains detailed feature and configuration information.
- Online Help

INSTALLATION

Installation is a quick, four-step process:

1. Assemble the scanner
2. Install the software
3. Connect and power on the scanner
4. Connect the USB cable to your computer

BEFORE YOU BEGIN

Please make sure of the following before you begin installation:

- If your computer has AntiVirus or AntiSpyware software running, you may see messages during installation asking you to allow the installation to proceed. Although the messages will differ based on the software your computer is running, in each case you should allow the installation to proceed. Alternatively, you can turn off the AntiVirus or AntiSpyware software before installing your scanner, but if you do, make sure to turn it back on again when installation is finished.
- If you already have a scanner connected to your computer, you need to remove its driver programs first before beginning the installation of your Visioneer Strobe XP 470 scanner. Please see “Uninstalling Your Scanner” on page 131 for basic instructions, or see the User’s Guide that you received with your other scanner for specific instructions.
- You had the option to purchase your Visioneer Strobe XP 470 based on the software bundled with the scanner. The information in this guide may cover software not provided with the scanner you purchased. Please disregard any information about the software not applicable to your chosen product.

STEP 1: ASSEMBLE THE SCANNER

To assemble the scanner:

1. Remove all shipping tape from the top and bottom of the scanner.
2. Carefully remove the protective foam from the ADF cover release, then press the release and open the automatic document feeder cover.

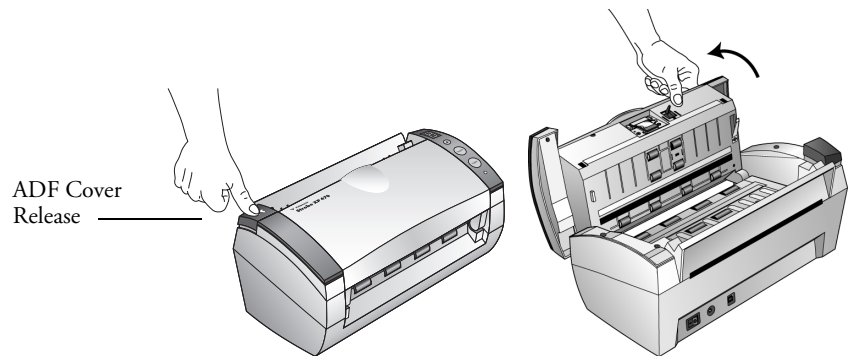

3. Carefully remove any foam particles that may have gotten inside the document feeder, and close the cover.
4. Align the slots on the paper guide with the ridges on the scanner and slide it down until it snaps into place.

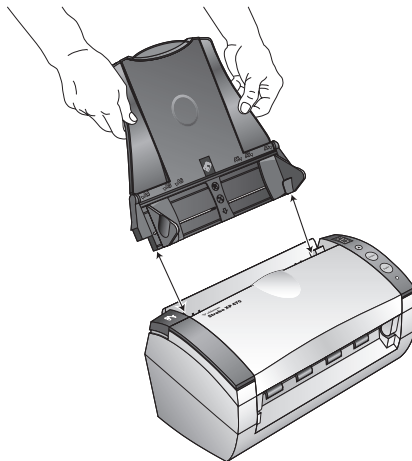

5. Insert the pins on each side of the output tray into the holes on the scanner.

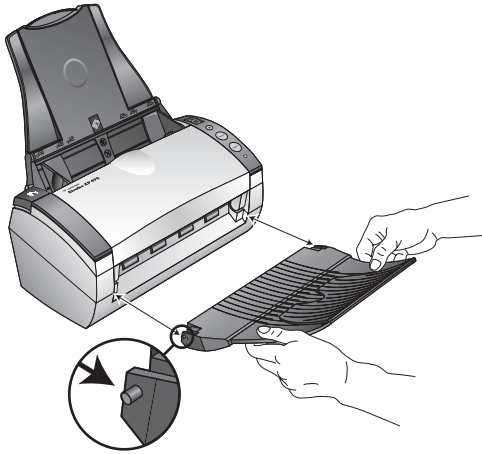

6. Flip open the extension on the output tray so it is fully extended.

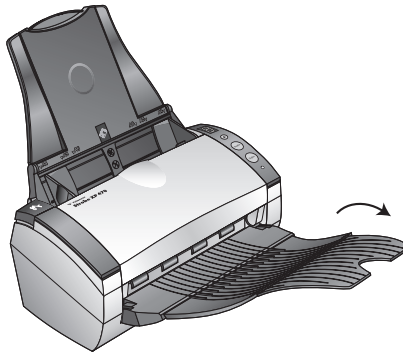

7. Proceed to “Step 2: Install the Software.”

STEP 2: INSTALL THE SOFTWARE

Note: The software is on the two CD's you received with your scanner. Please be sure to install from **Disc 1** first. **Disc 2** contains the OmniPage 12 software that you install after the scanner software.

To install the software:

1. Start Microsoft Windows and make sure no other applications are running.
2. Insert **Disc 1** into your computer's CD-ROM drive.

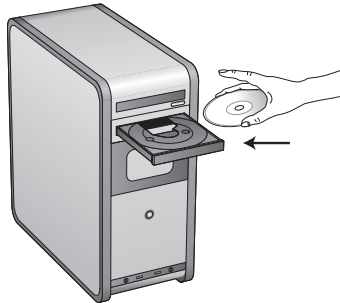

The Options Menu for the CD automatically opens.

Note: If the CD does not start, check the following:

- Make sure the CD drive's door is completely shut.
- Make sure the CD was inserted in the drive in the proper direction (label side up).

To launch the CD manually:

- Open the Windows option for My Computer. You can do this by double-clicking on the My Computer icon on your desktop.
- Double-click the icon for your CD-ROM drive.
- The Installation menu for the CD should now open.

If the menu does not open:

- From the list of files on the CD, double-click the file named START32.EXE.
-

3. On the installation menu, select **Install ScanSoft PaperPort**.



4. At the PaperPort 9.0 Welcome window, click **Next**.
Installing PaperPort 9.0 will uninstall any existing versions of PaperPort and install PaperPort 9.0 while retaining all of your PaperPort files.
5. Read the ScanSoft license agreement and select **I accept the terms in this agreement** then click on **Next**. If you choose not to accept the license agreement, the installation will terminate and the PaperPort software will not be installed.
6. Fill in the Customer Information then click on **Next**.
7. Keep the default Setup Type and click on **Next**.
8. Click on **Install** to begin the installation.

Reminder: If your computer is running an AntiVirus or AntiSpyware application, you may see messages asking you to allow installation. Select the option to allow installation to proceed with the install.

9. At the Product Registration window, do one of the following:
 - Select **Register online**, then click **OK** and follow the registration instructions.
 - Select **Print registration form**, then click **OK** and follow the instructions to complete and print the registration form.
 - Select **Remind me in 7 days** and click **OK**.
10. At the Installshield Wizard Completed window, click **Finish**.
If a message window opens instructing you to restart your computer, click **Restart**.
11. At the Installation Menu, select **Install Scanner Driver**.



The Welcome to the OneTouch 4.0 Setup Wizard opens.

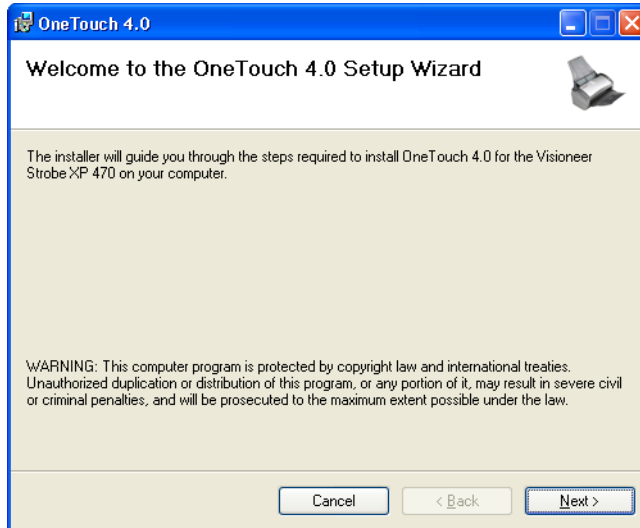

12. Click **Next**.
13. On the Visioneer License Agreement window, read the license agreement. If you accept the terms, select **I Agree** then click **Next**.
If you choose not to accept the license agreement, the installation will terminate and the scanner driver will not be installed.

The next window lists the choices of the drivers that you can install for your scanner.

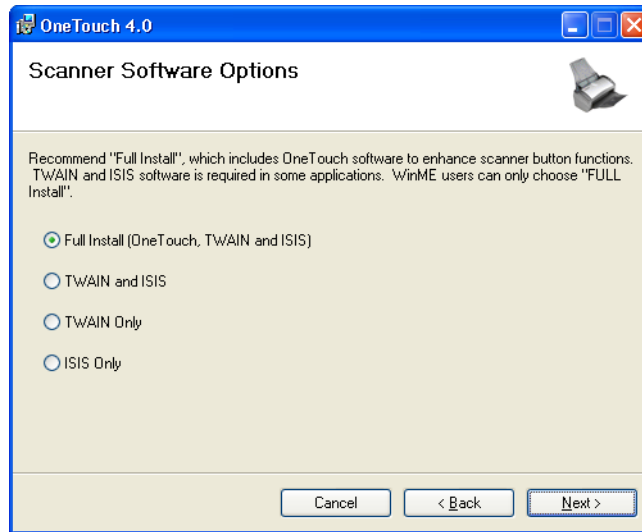

14. Choose the option you want.

- **Full Install (OneTouch, TWAIN and ISIS)**—This is the **recommended** installation. It installs the OneTouch 4.0 software which provides the necessary driver software for the scanner. It also installs scanning interfaces for TWAIN, Microsoft's Windows Image Acquisition (WIA), and the ISIS driver. Installing this option means that you can use several different methods to scan, as explained in this User Guide. **Note:** If your computer is running Windows Me, you must select this **Full Install (OneTouch, TWAIN and ISIS)** option. The other options do not apply to Windows Me computers.
- **TWAIN and ISIS**—The TWAIN and ISIS drivers are installed. The OneTouch 4.0 Monitor will not run and you cannot use the OneTouch features. You can use the Visioneer Strobe XP 470 TWAIN driver, and scan from other applications with a TWAIN interface. You can also scan from applications that use the ISIS driver.

- **TWAIN only**—The TWAIN driver is installed. The OneTouch 4.0 Monitor will not run and you cannot use the OneTouch features. You can use the Visioneer Strobe XP 470 TWAIN driver, and scan from other applications with a TWAIN interface.
- **ISIS only**—The ISIS driver is installed. You can scan from applications that use the ISIS driver, such as Kofax VRS and QuickScan, and you can also use the Kofax TWAIN driver. But the OneTouch 4.0 Service will not run. You will not be able to use the Visioneer Strobe XP 470 TWAIN driver.

Note: If decide to change your scanner's installed drivers later on, you must first uninstall the drivers the scanner is currently using. See the instructions on page 15.

15. Click **Next**.

During installation of the **Full Install** you will see this window asking you to select one of the images for your Color Space setting.

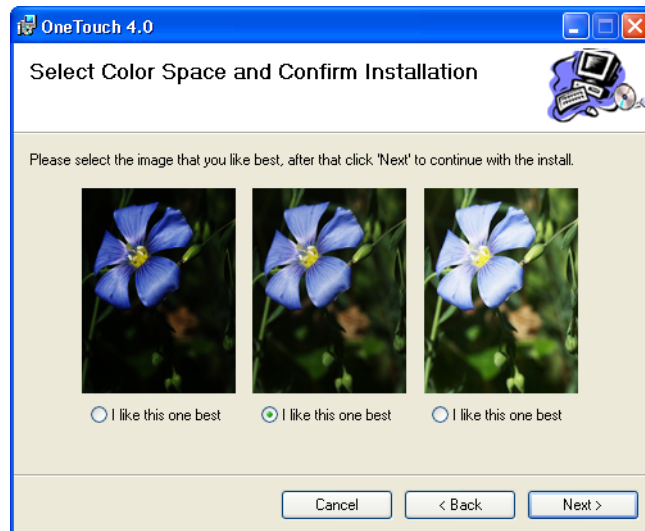

The Color Space setting sets the gamma value for the scanner so scanned items look good on your monitor. Gamma controls the brightness of the midtones of colors. This setting can be changed later on as you are scanning.

16. Select the option that looks best to you and click **Next**.

The driver installation will now begin.

17. **STOP** when you see the “Complete the installation by connecting your hardware” window. Do **NOT** click on **OK** yet. Leave the window open and proceed to “Step 3: Connect and Power On the Scanner” on page 16.

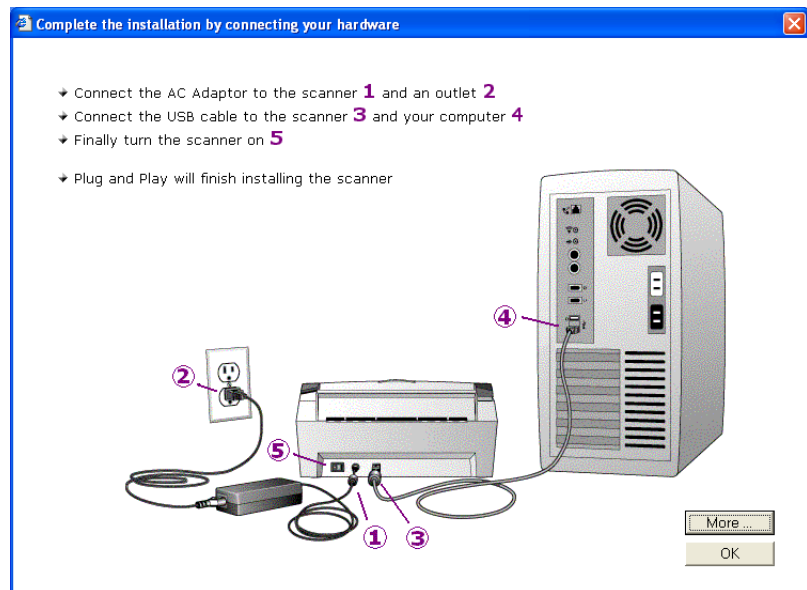

Reminder: If your computer is running AntiVirus or AntiSpyware software, you may see messages asking you to allow installation. Select the option to allow installation to proceed.

Note: If you want to see more information about your scanner and a quick explanation of how to use the OneTouch features, click on the **More** button on the window. After you have read more about your scanner, return to the Connect Scanner window and proceed to “Step 4: Connect the USB Cable” on page 17.

TO INSTALL ANOTHER DRIVER

Before you can install another driver for your scanner, you must remove the currently installed driver first. Then the new driver can be installed.

1. Remove the scanner from the system.
 - a. Open the Windows Control Panel then double-click on the **System** icon.
 - b. Select the **Hardware** tab then click on the **Device Manager** button.
 - c. Find and select **Imaging Devices** then select the **Visioneer Strobe XP 470**.
 - d. Choose **Uninstall** from the **Action** menu.
2. Unplug the scanner USB cable.
3. Uninstall the OneTouch 4.0 driver.
 - a. Open the Windows Control Panel.
 - b. Double-click on **Add/Remove Programs**.
 - c. Select OneTouch 4.0 then click on the **Remove** button.
4. Follow the instructions in “Step 2: Install the Software” on page 8 of this User Guide and follow steps for completing a custom driver installation.

STEP 3: CONNECT AND POWER ON THE SCANNER

Connect the power supply and power cord, and then turn the power on.

To connect your Visioneer Strobe XP 470 scanner:

1. Plug the power supply into the power port on the scanner.



Note: Only use the power supply (SA60-24 made by Sino-American) included with your scanner. Connecting any other type of power supply may damage your scanner, and will void its warranty.

2. Plug the power cord into the power supply and into a wall outlet.

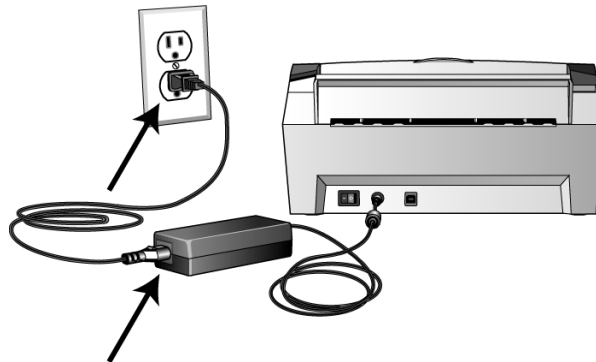

3. Turn on the power switch, located on the back of the scanner to the left of the power port.

The status light comes on and flashes indicating that the scanner is receiving power.

Now proceed to the next section, “Step 4: Connect the USB Cable.”

STEP 4: CONNECT THE USB CABLE

The Visioneer Strobe XP 470 scanner connects to any available USB port. Check your computer’s manual for USB port locations.

Note: You can connect the scanner to your computer while the computer is running. You do not have to shut down your computer.

1. Plug the USB cable into the USB port on the scanner and then into a USB port on the computer. The ports are identified with the USB symbols.

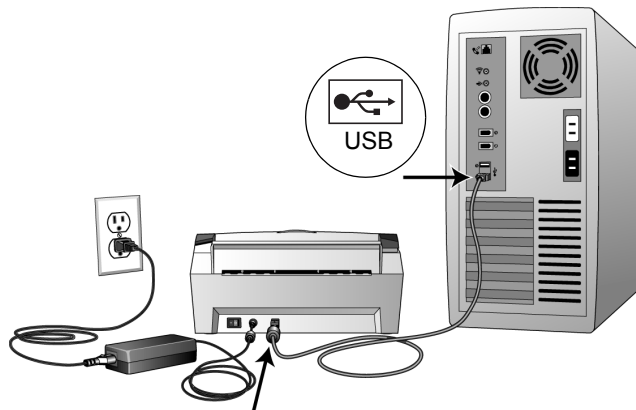

You can also connect the scanner to a USB hub. If you use a USB hub, it must have its own power supply already plugged into an electrical outlet.

Note: If you have not installed the scanner driver, unplug the USB cable from the computer and install the software now. When the driver installation is complete, a message tells you when to connect the scanner.

If you are using Windows XP, Service Pack 1, and have plugged the USB cable into a USB 1.1 port, an information bubble may open explaining that “A HI-SPEED USB device is plugged into a non-HI-SPEED USB hub”. Plug the USB cable into a USB 2.0 port (if available) or just disregard the message. If you leave it plugged into the USB 1.1 port, your scanner may scan a bit slower than the 33 pages per minute, and 66 images per minute available with a USB 2.0 port.

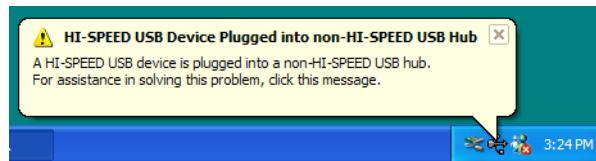

Your computer then recognizes that a scanner has been plugged into the USB port and automatically loads the appropriate software to run the scanner.

Do not proceed until you receive a message that your computer has found the new hardware, or updated the driver database. If your computer is running Windows XP, you will see the following message.

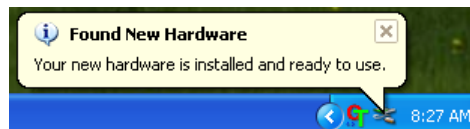

2. When you're certain that the software has completely loaded, return to the "Complete the installation by connecting your hardware" window and click **OK** to complete the installation process.

You can also click **More** to see a quick overview about accessing and navigating the OneTouch Button Panel. When you're finished reading the additional information, click **OK**.

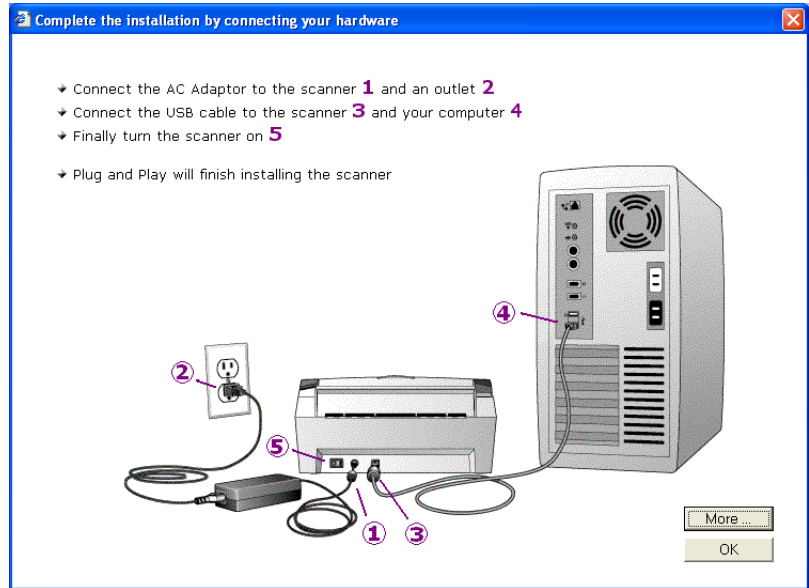

The scanner's status light is green when the scanner and computer are communicating properly.

3. Click **Close** at the OneTouch 4.0 Installation Complete window.

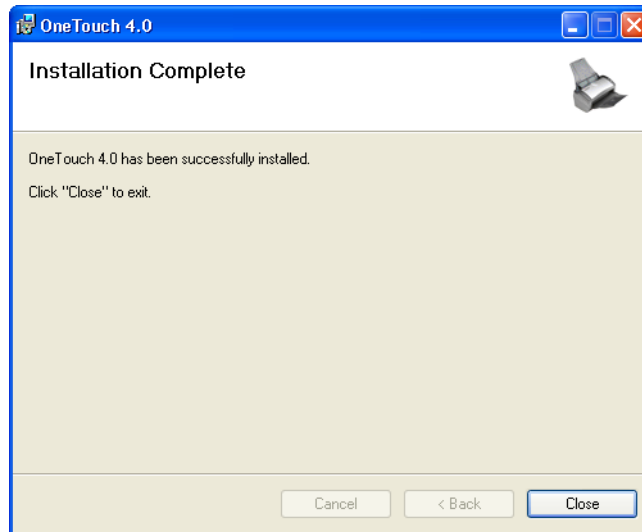

4. You can now remove the installation CD so you can install the OmniPage 12 software from the **Disc 2** CD that you received with your scanner.

INSTALL OMNIPAGE 12 AND ADDITIONAL SOFTWARE

Both CDs that you received contain additional software for your scanner:

- **Disc 1** contains a new version of Adobe Acrobat Reader
- **Disc 2** contains the OmniPage 12 software

Note: OmniPage 12 is required for your scanner to have its full range of features. Please make sure to install OmniPage 12 before scanning.

To install OmniPage 12:

1. Make sure the Installation CD is removed from your computer's CD-ROM drive, and then insert **Disc 2** into the drive.

The menu for the CD automatically opens.

If the menu does not automatically open, see the note on page 8.

2. Select **OmniPage 12** to install.
3. Follow the instructions on the screen.
4. When installation is finished, remove **Disc 2** and store it in a safe place.

To install additional software:

1. Make sure that **Disc 2** is removed from your computer's CD-ROM drive, and then re-insert the Installation CD (**Disc 1**) into the drive.

The Installation menu will open automatically.

If the menu does not automatically open, see the note on page 8.

2. Select **Additional Software and Guides**.



3. At the next set of menu options, click on **More Great Software**.



4. Select the software application that you want to install and follow the installation wizard for that product.

Adobe Acrobat Reader is included under More Great Software. If your computer already has a later version of Adobe Acrobat Reader installed, please do not install the version provided on the installation CD.

5. To view, print, or save the user guides, click **User Guides** in the **Additional Software and Guides** menu.

Select the user guide you want to view. After the file opens, you can choose to print or save it using the application's "File" menu.

Note: The user guides are in a .pdf file format. If you do not have Adobe Acrobat Reader installed on your computer, you will not be able to view these user guides.

6. When you have finished, remove the CD from the computer and store it in a safe place.

That's it! You are now ready to scan!

REGISTER YOUR SCANNER

Registering your scanner is very important because it provides you with access to our free telephone support service. Registration also gives you free access to software updates for your scanner.

To register your scanner:

1. Right-click on the OneTouch icon in the Windows Notification Area (at the bottom right corner of the screen).
2. Choose **Check for Online Updates...** from the pop-up menu.

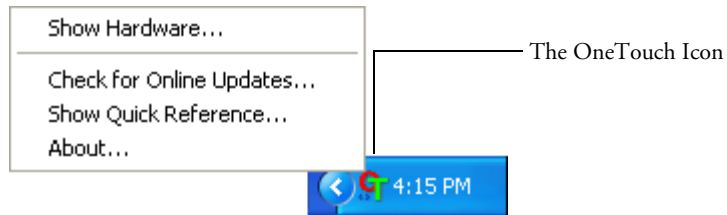

3. Follow the instructions on the screen and register your scanner by entering your scanner's serial number and your email address.

Note: A valid email address is required.

The serial number is located on the underside of the scanner.

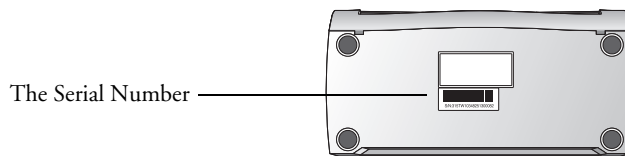

After registration is complete you will receive an email message with your RegID. Your RegID is important as you will need it when accessing free telephone support, or checking for online updates.

4. Write down your RegID below so you will always know where to find it.

RegID: _____

Scanning

When you press either the Simplex or Duplex button, documents are scanned using the scan settings indicated by the LED number. The scanned images are then sent to a software application (known as the Destination Application) on your computer.

LOAD AND SCAN DOCUMENTS

1. Make sure the output tray is fully extended, and adjust the paper guide for the width of paper.

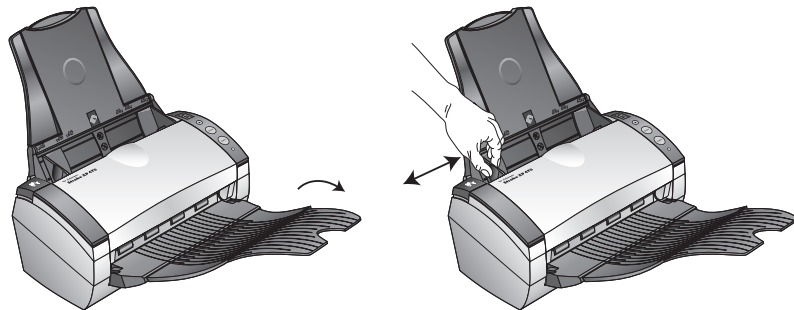

Note: Remove any staples or paper clips from documents before loading them into the automatic document feeder. Staples and paper clips can jam the feed mechanism and scratch the internal components.

2. Load the documents with their tops into the automatic document feeder.

For Simplex (one-sided) scans, load the documents *face down*.

For Duplex (two-sided) scans, the documents can be face up or down because both sides are scanned.

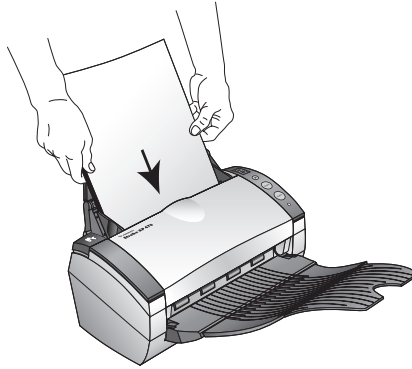

3. Check the LED number to make sure you're using the scan setting you want.

To choose a new scan setting, press the Destination Selector button.

The current scan setting. See "Check the Scan Settings Before Scanning" on page 28 to check the settings.

Press the Destination Selector to cycle through the scan settings to select the one you want.

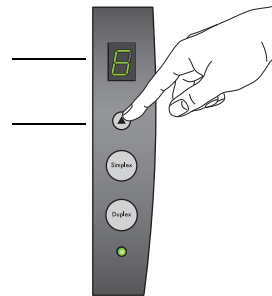

4. To scan a one-sided document, press the **Simplex** button.
To scan a two-sided document, press the **Duplex** button.

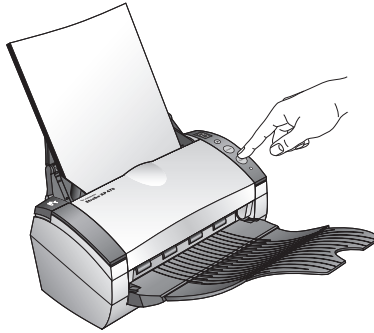

A scan progress window opens and then a thumbnail of the scanned image appears in the Destination Application. In this example of duplex (two-sided) scanning, the Destination Application is the PaperPort desktop and the two pages are stacked, one on top of the other.

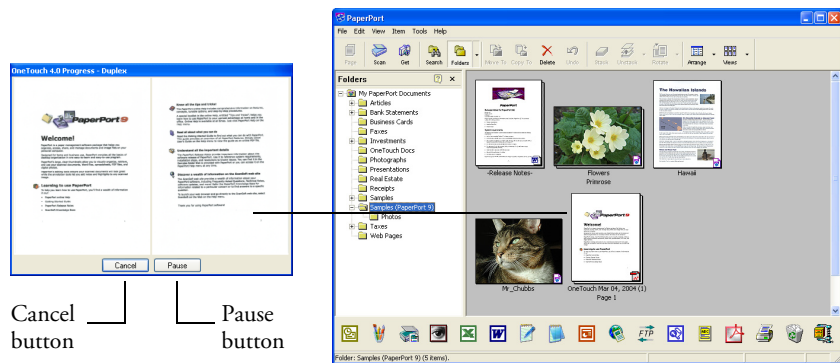

To Cancel scanning, click the **Cancel** button.

To pause the scanning, click the **Pause** button. It will change to a **Continue** button. Put the page back into the scanner and click **Continue** to resume scanning.

CHECK THE SCAN SETTINGS BEFORE SCANNING

1. To check the scan settings before scanning, *press, hold down, and then release*, either the **Simplex** or **Duplex** button.

Press, *hold down, and then release* either button to see the setting for the selected LED number.

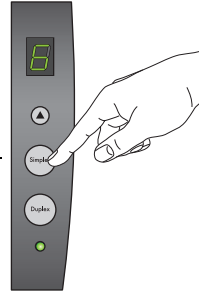

The OneTouch Button Panel appears with the description of the selected settings. This sample shows the current description of setting 6.

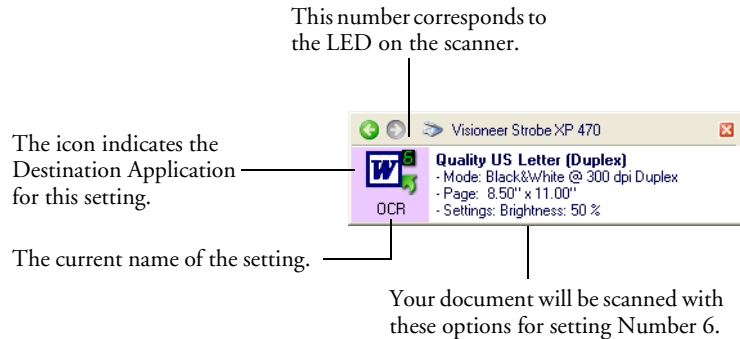

The OneTouch Properties window for that setting also appears in case you want to change scanning options before scanning.

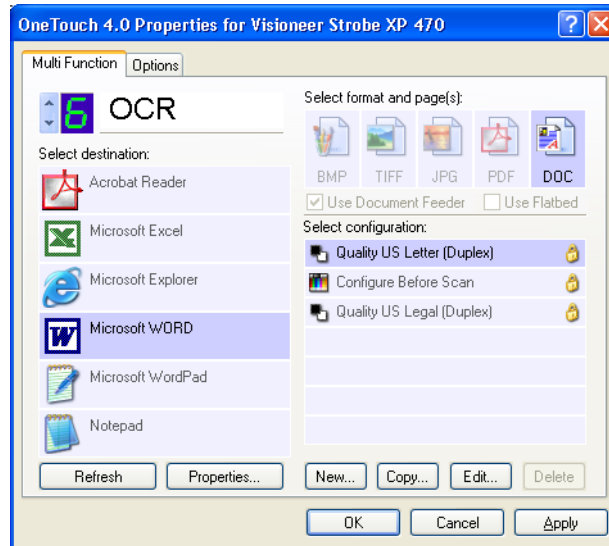

Use this window to reset the button settings for the destination applications, file formats, and so forth. See “Configuring the OneTouch Buttons” on page 35 to reset the settings.

2. Click the close boxes on the OneTouch Button Panel and the Properties window to close them.

SCAN FROM THE ONETOUCH BUTTON PANEL

You can scan from the OneTouch Button Panel on the screen.

1. Adjust the paper guide for the width of paper and load the documents with their tops into the automatic document feeder.

For Simplex (one-sided) scans, load the documents *face down*.

For Duplex (two-sided) scans, the documents can be face up or down because both sides are scanned.

The OneTouch Icon



2. Now click on the OneTouch icon in the Windows System Tray (at the bottom right corner of the screen).

The OneTouch Button Panel appears and shows the first five on-screen scanning buttons. Click the arrows to cycle through all 9 settings.

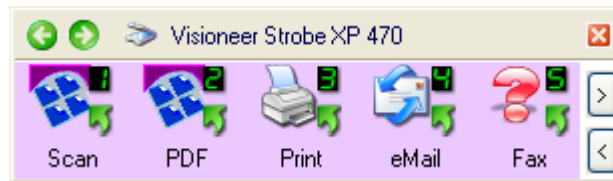

Click the button you want to use to scan.

Click these arrows to navigate through the 9 buttons.

The Properties window also appears in case you want to change the scanning options before scanning.

- On the screen—not on the scanner—click the button you want to use to scan.

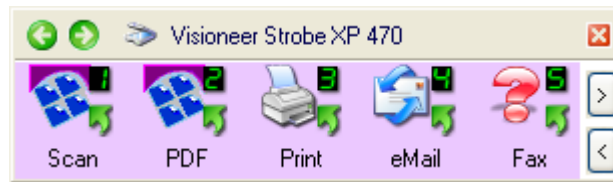

For example, if you want to scan with button 2, which converts the document to PDF, click here.

Or if you want to scan with button 4, which attaches the scanned document to a blank eMail message, click here.

Note: Your scanner comes with 9 factory-preset OneTouch button settings. You can reconfigure and rename the buttons for your specific scanning requirements.

The scanner begins scanning. When the process finishes, the scanned images appear in the Destination Application, just as if you scanned with the Simplex or Duplex scanner buttons.

USING THE ONETOUCH BUTTON PANEL

The OneTouch Button Panel is also your on-screen set of controls for the scanner. The OneTouch Button Panel shows information about the scanner and its settings.



- To open the OneTouch Button Panel, click the OneTouch icon. It is located in the Windows System Tray at the bottom right corner of the screen.

The OneTouch Button Panel opens at its Button View, which shows the on-screen scanning buttons.

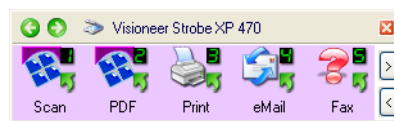

The Button View

- To scan from the panel, click the icon you want to use to scan.
- To see the details for a button, right-click on it. The Properties window for that button also appears.

Right-click on a button to see its details in the Detail View and Properties Window.



Clicking the icon in either view starts the scanner scanning using the button's settings.

The Detail View

- To cycle through the nine buttons, click the arrows on the right side of the panel.

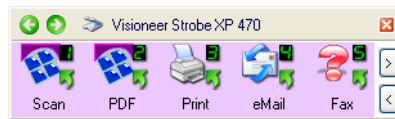

Click these arrows to cycle through the 9 buttons.

- To navigate through the panel's three views, click the green arrows at the top of the panel.

Click these arrows to navigate through the panel's three views.

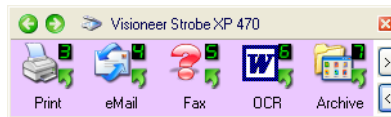

The Button View

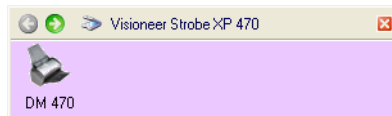

The Hardware View

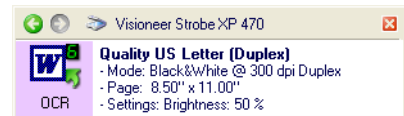

The Detail View

- The Button View is your main scanner control panel. Use it to scan or to see all nine buttons.
- The Detail View shows the current scan settings for a button.

- The Hardware View shows the current scanners connected to your computer.

If the Properties window is not open, right-click the icon on the Detail View or Button View to open it.

From the Hardware View and Detail View, click the green arrow to return to the Button View. You can also click on the hardware icon to return to the Button View.

6. To close the OneTouch Button Panel, click the close button on the panel.

ABOUT THE ONETOUCH BUTTON PANEL'S NAMES AND ICONS

The button names, such as PDF, eMail or Fax, indicate the original factory settings for a button. For example, the eMail button is set up to scan documents and then immediately attach them to a new eMail message in Microsoft Outlook Express. But you can change the name, the Destination Application, and any of the other aspects of the button.

A question mark for a button, such as shown for button 5 in the examples above, means your computer does not have appropriate software for the initial factory settings (Fax software in the example above). In that case, you would probably want to change the name and Destination Application to something else. For example, if you scan a lot of documents that have faint images, such as hand-drawn sketches in light pencil, you might want to change the button's name to Sketches, and the Destination Application to Microsoft Paint, or some other drawing program.

See "Configuring the OneTouch Buttons" on page 35 to change the settings of the buttons on the OneTouch Button Panel.

SCANNING FROM OTHER SOFTWARE

In addition to scanning from the scanner buttons and the OneTouch Button Panel, you can scan directly from PaperPort and other software. See the sections "Scanning from PaperPort" on page 95 and "Scanning with the Windows Image Acquisition" on page 119 for details.

THE DEFAULT ONETOUCH SETTINGS ON YOUR SCANNER

When you receive your scanner, its settings are preconfigured to scan items for various basic tasks, such as email or fax, and then send the scanned image to an appropriate, preselected Destination Application. The following table shows these factory-default settings. *You can change any of these settings.*

Button	Name	Destination Application	Preconfigured Settings
1	Scan	PaperPort	Black&White @ 200dpi Duplex 8.5" x 11" page Brightness 50%
2	PDF	PaperPort	Black&White @ 200dpi Duplex 8.5" x 11" page Brightness 50%
3	Print	Printer	Black&White @ 300dpi Simplex 8.5" x 14" page Brightness 50%
4	eMail	Microsoft Outlook (attachment)	Black&White @ 200dpi Simplex 8.5" x 11" page Brightness 50%
5	Fax	Fax Application	Black&White @ 200dpi Simplex 8.5" x 11" page Brightness 50%
6	OCR	Microsoft Word	Black&White @ 300dpi Duplex 8.5" x 11" page Brightness 50%
7	Archive	Transfer to Storage	Black&White @ 300dpi Simplex 8.5" x 11" page Brightness 50%
8	Custom	Microsoft Paint	Color @ 100dpi Simplex 6" x 4" photo size Brightness 50% Contrast 50%
9	Paint	Microsoft Paint	Color @ 300dpi Simplex 8.5" x 11" page Brightness 50% Contrast 50%

CONFIGURING THE ONE TOUCH BUTTONS

Each OneTouch button configuration consists of a **Destination Application**, a **Scan Configuration**, and a **Document Format**. The OneTouch Properties window is where you select these three elements for a button.

To open the OneTouch Properties window:



1. Click the OneTouch icon. It is located in the Windows System Tray at the bottom right corner of the screen.
2. Right-click a button on the OneTouch Button Panel.

Reminder: Remember that left-clicking a button on the OneTouch Button Panel starts the scanner scanning. *Right-clicking* opens the OneTouch Properties window.

The OneTouch Properties window opens for that button.

Right-click on a button (for example, button 2) and the Properties window opens for that button.

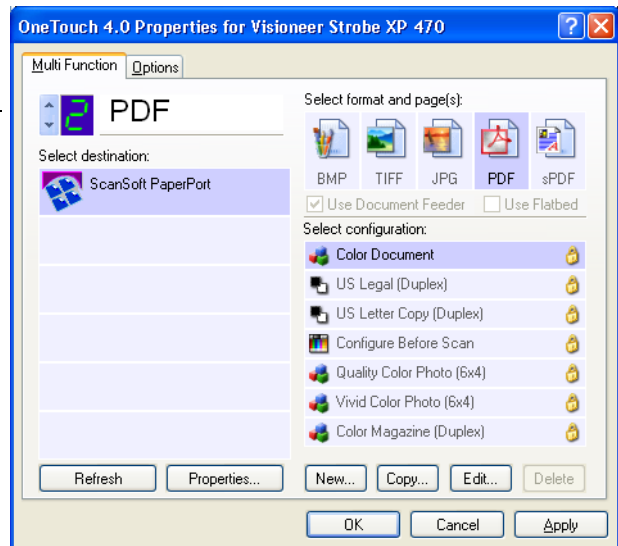
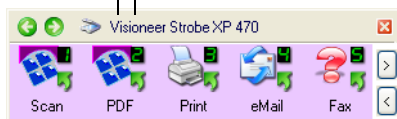

The OneTouch Properties window also opens when you press, hold down, and release the Simplex or Duplex button on the scanner.

ABOUT THE ONETOUCH PROPERTIES WINDOW

The OneTouch Properties window is where you can select new settings for the buttons. The OneTouch Properties window also has special scanning features such as scanning to a CD, scanning and converting text directly into an HTML web page, and scanning with optical character recognition (OCR) that turns a scanned image into text that you can edit.

Note: Some of the options on the OneTouch Properties Window (and other OneTouch windows and dialog boxes) are “grayed out” and are not available. Grayed out options are not appropriate for your Visioneer Strobe XP 470 scanner. For example, on the figure below, the option “Use Document Feeder” is selected and “grayed out” because the Visioneer Strobe XP 470 is an ADF scanner and always uses the document feeder, so there’s no reason for you to select it. If you use the OneTouch application with other Visioneer scanners, grayed out options become active, if appropriate.

The following example of the OneTouch window shows the settings for Button 2. The button is set to scan with the scan configuration named Color Document and then open ScanSoft PaperPort to display the scanned image. The Format and Page(s) option is set to scan in the PDF image format.

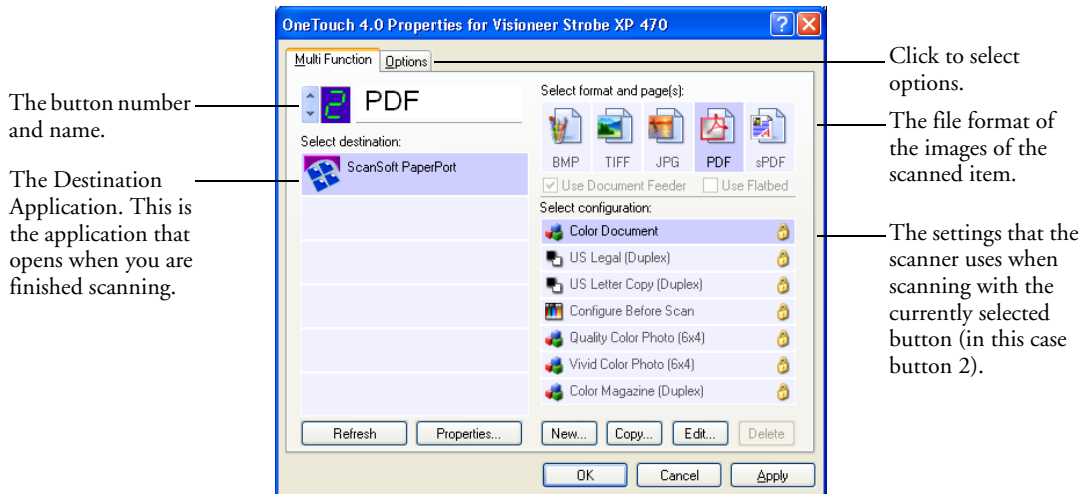

The settings on the Properties window are:

Select Destination—The list of applications that can open to display the scanned image for the selected button. To configure the list of available applications, click the Options tab at the top of the dialog box and select the desired options. See “Selecting Options for a Button” on page 55 for more information.

Select Configuration—The list of available scan configurations for the selected button. The configuration settings include: scanning mode, resolution (dpi), page size, brightness, color saturation, hue, and gamma. To see a selected scan configuration’s settings, click its icon. Click the icon again to close the detailed information.

Click the icon of a selected configuration to view its settings.

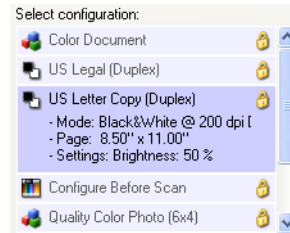

The icons next to each scan configuration indicate the scanning mode.



Color



Black and White



Grayscale



Configure
Before Scan

Note: Use **Configure Before Scan** if you want to set the scanning mode manually before scanning. See “Configuring Before Scanning” on page 68.

You can also click the **Edit** button or double click the configuration to see more detailed information about the selected configuration.

Select Format and Page(s)—A set of file formats for the scanned image for the selected button. The formats are based on the type of destination application you select. This example shows the formats that apply to the PaperPort Desktop.

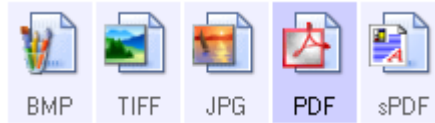

The button names indicate their file types. See “Selecting Page Format Options” on page 49 for more about the formats.

Options tab—Displays a window for selecting options related to the selected destination application for the scanned image.

SELECTING NEW SETTINGS FOR A BUTTON

For each of the nine OneTouch buttons, you can select a new **Destination Application**, **Scan Configuration**, and **Document Format**.

Click these arrows to see the properties for the button whose settings you want to change.

Select a software application as the destination to send scanned documents.

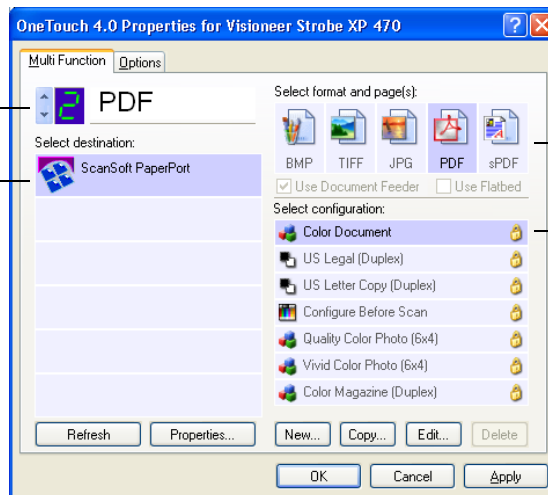

Select a format for the scanned image

Select a configuration for scanning the item.

To select new settings for the Scanner Button:

1. Click the button selection arrows to select the button you want to change.

Each button has its own settings. So, as you click the arrows to cycle through the buttons, the available settings on the window change to show them for each button.

2. From the Select Destination list, select the application where you want documents sent when scanning is finished.

See “Selecting Options for a Button” on page 55 to display a full list of the Destination Applications that you can use with the scanner.

Note: If you select a word processing program such as Microsoft WordPad or Microsoft Word and a page format that can be used for OCR (such as Text, RTF, Word, sPDF, or nPDF), the text in scanned images is automatically converted to word processing text. See “Scanning with Optical Character Recognition (OCR)” on page 70 for details.

3. From the Select Configuration list, select a scan configuration.



To scan in color, select one of the configurations indicated by the small color icon, such as the Color Document configuration.

The scan configuration list is preset for the application you select in the Select Destination list. If you select a different application, the configurations are for that application. However, you can create your own scan configurations as well.

4. Select a Format and Page(s) option.

The available options apply to the Destination Application you select. For example, if you select Microsoft Word as the Destination Application, the available formats are for text, such as .doc, .txt, and .rtf. But if select Microsoft Paint as the Destination Application, then the available formats are for graphics, such as .bmp, and .jpg.

- Click OK, or if you want to keep the window open and work with other features, click Apply.

Now when you press or click a scanner button, the document is scanned using the newly configured settings for that button.

SETTING DESTINATION APPLICATION PROPERTIES

The different types of Destination Applications have various properties that you can select.

- On the OneTouch Properties window, click a Destination Application.
- Click the **Properties** button.

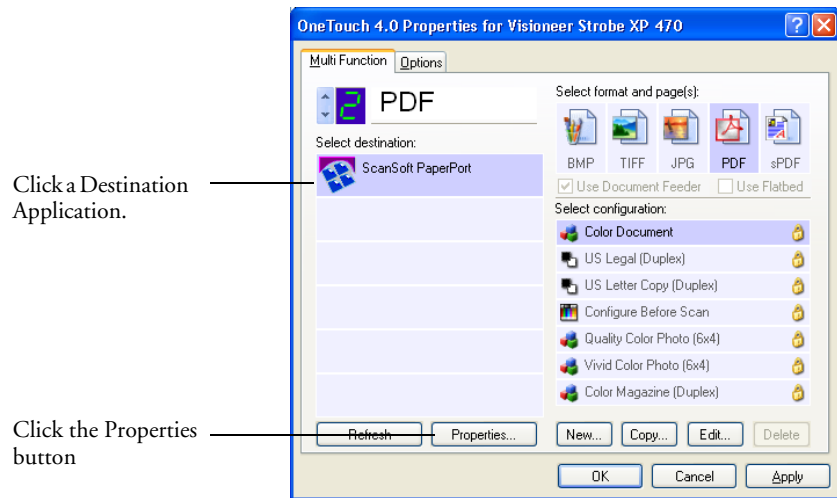

A OneTouch 4.0 Link Properties dialog box appears for the type of Destination Application you selected, and the available options are for that type of application.

PAPERPORT PROPERTIES

These properties apply to PaperPort, and are for designating the folder to receive your scanned items.

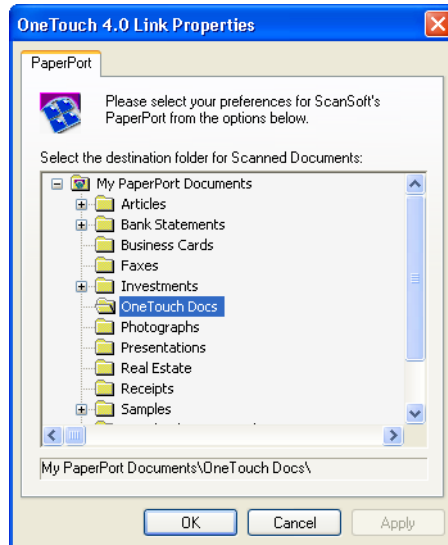

1. Select the PaperPort folder where you want the file of the scanned image to be located.
2. Click **OK**.
3. Click **OK** or **Apply** on the OneTouch Properties window.

When PaperPort opens after you finish scanning, the thumbnails of your scanned documents are on the Desktop in that folder.

TEXT DOCUMENTS PROPERTIES

These properties apply to Microsoft Word, Excel, Adobe Reader, and the other applications indicated by their icons in the list. The properties apply to the OCR settings for the applications.

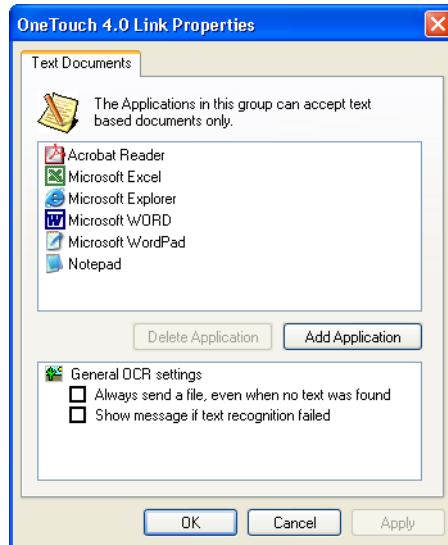

1. Click in the OCR settings boxes for the options you want.

The options will apply to all the applications in the group.

Always send a file, even when no text was found—The scanned file is sent to the OCR reader even if the image does not appear to contain text. This could occur if you scanned a photograph with a OneTouch button set for text applications.

Show message if text recognition failed—A message will appear on the screen if the OCR reader does not detect text in the image.

2. To add another application to the list, click the **Add Application** button.

The Add Text Based Link dialog box appears.

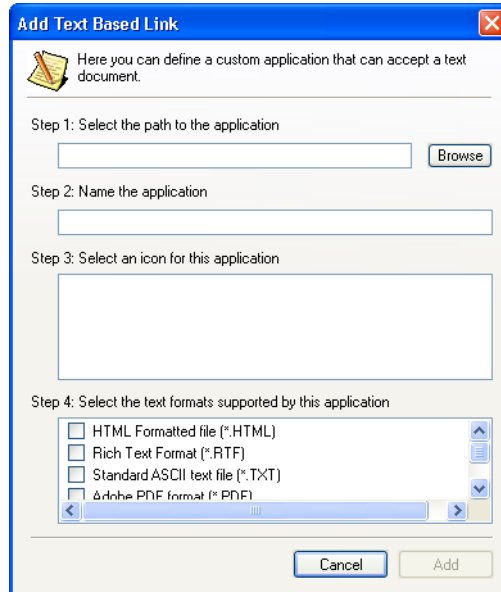

3. Click **Browse** to find the application you want to add to the list.

When you select the application using the Browse button, steps 1, and 2 on the dialog box are automatically filled in, and the application icon appears in step 3.

4. Select the icon in Step 3.

To select the options in step 4 on the dialog box, refer to the documentation that you received with the application to see which text formats it supports.

The boxes you select here determine the Page Format icons that appear on the OneTouch Properties window for that group of applications.

5. Click the **Add** button.
6. Click **OK** or **Apply** on the OneTouch Properties window.

IMAGE DOCUMENTS PROPERTIES

These properties apply to ScanSoft OmniPage Pro 12 that you received with your scanner, plus Microsoft Paint and other image processing applications.

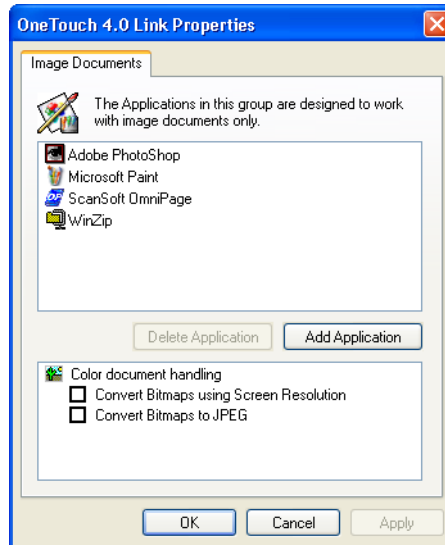

1. Click in the Color document handling settings boxes for the options you want.

The options will apply to all the applications in the group.

Convert Bitmaps using Screen Resolution—Use this option to ensure that an image will fit on the computer's screen. When a computer screen is set to a lower resolution, bitmap images with a higher resolution may be too big to fit on the screen. Converting the bitmap image to match the screen resolution ensures that the image fits on the screen.

Convert Bitmaps to JPEG—JPEG files can be compressed to produce smaller file sizes and, therefore, shorter transmission times. Use this option to provide that compression capability to image files.

2. To add another application to the list, click the **Add Application** button.

See the steps on page 43 to add an application to the list.

3. Click **OK**.
4. Click **OK** or **Apply** on the OneTouch Properties window.

STORAGE PROPERTIES

These properties apply to the Destination Application named Transfer to Storage. If a CD burner is attached to your computer, you also use this dialog box to start the Burn to CD process.

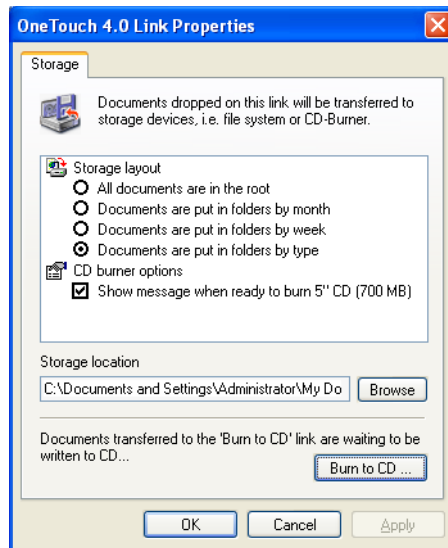

Note: If you do not have a CD burner attached to your computer, the CD options are not shown on the dialog box. The Burn to CD option is only available for Windows XP.

1. Click the Storage Layout options you want.

All documents are in the root—The scanned documents are saved in the root of the folder specified in the Storage Location.

Documents are put into folders by month, week, or type—

Folders are created based on your selection (month, week, or type) and the scanned documents are saved in those folders. New folders are created for each month and week so you can keep track of when you scanned the documents.

2. Click the **Browse** button to specify the location to store the scanned documents, or type a location directly into the box.

If you are scanning to a shared network drive, it must be a mapped drive. For more information about mapped drives, see your network administrator.

3. If you have a CD burner attached to your computer, the option **Show message when ready to burn 5" CD (700MB)**, should be selected.

You'll see a message when it's time to click the **Burn to CD** button.

4. Click **OK**.
5. Click **OK** or **Apply** on the OneTouch Properties window.

EMAIL PROPERTIES

These properties apply to eMail applications so you can specify the folder for documents that you will attach to an eMail message. Microsoft Outlook and AOL Version 9 accept direct attachment of documents to a blank eMail message as soon as scanning is finished, but other eMail applications do not. If you're using one of those applications, you need to know which folder contains the scanned documents so you can manually attach them to your eMail messages.

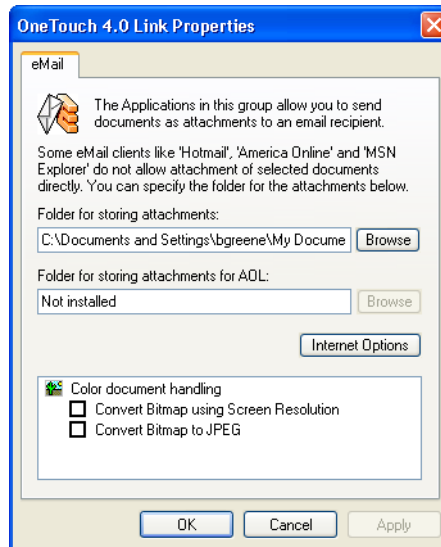

1. Click the **Browse** button for **Folder for storing attachments** and choose a folder for your eMail attachments.
2. Click the **Browse** button to specify the location to store them, or type a location directly into the box.

See the steps on page 45 to add an application.

3. If you are using America Online (AOL) on your computer, and the folder name for AOL is incorrect, click the **Browse** button and find the correct AOL folder.

Normally the folder that AOL uses to store attachments will be listed in the box. For AOL versions prior to version 9.0, the folder has to be the specific folder AOL uses to find attachments. AOL 9.0, however, can attach documents automatically after scanning is finished.

4. If you need to set or change any internet options for AOL click the **Internet Options** button.

The Windows Internet Options Control Panel appears. See your Windows documentation and AOL user manual for the settings on the Windows Control Panel.

5. Select the options for color document handling.

Convert Bitmaps using Screen Resolution—Use this option to ensure that an image will fit on the computer's screen. When a computer screen is set to a lower resolution, bitmap images with a higher resolution may be too big to fit on the screen. Converting the bitmap image to match the screen resolution ensures that the image fits on the screen.

Convert Bitmaps to JPEG—JPEG files can be compressed to produce smaller files sizes and, therefore, shorter transmission times. Use this option to provide that compression capability to image files.

6. Click **OK**.
7. Click **OK** or **Apply** on the OneTouch Properties window.

SELECTING PAGE FORMAT OPTIONS

The Page Format options that you select determines the file format of the scanned document. Appropriate page format options and file types are available for the type of Destination Application selected for the button.

The available options are for images and text.

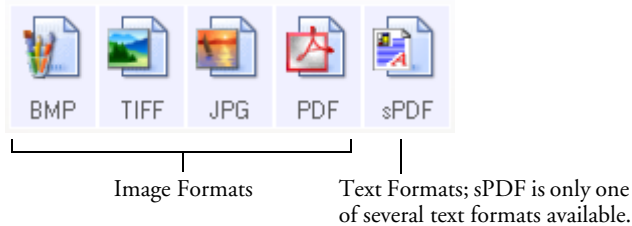

The Text Formats are for text file types. The names of the formats indicate their file types. See “Text Formats” on page 51 for details.

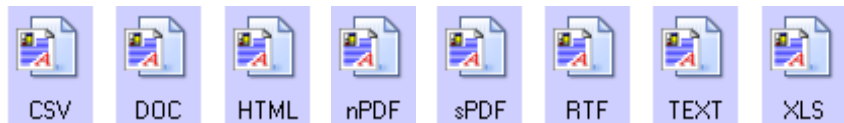

IMAGE FORMATS

Select an image file format for photos, artwork or other documents that you want to save as images. BMP and TIFF are standard image file formats generally used if you want to do additional image processing, such as photo touch-up or color correction. Both of those file formats tend to be larger than the JPEG format.

Because JPEG image files can be reduced in size, the JPEG format is often used for images on web pages, or if file size might be a problem when electronically sending the files. JPEG files are reduced in size by lowering their image quality, and you can select the degree of quality for your scanned images from the JPEG file format icon.

The PDF format is often used to create images of text pages. You may want to select PDF as the page format when scanning text pages that do not require OCR processing or other processing. The PDF format is also used to put multi-page documents on web sites as pdf-readable files. As with the JPEG option, the PDF format can be reduced in size or quality.

Note: The two other PDF formats—nPDF and sPDF—are for scanning with OCR processing and with the ability to search the scanned text. See the next section, “Text Formats,” and also “Scanning with sPDF or nPDF and Searching for Text” on page 79 for details.

To select a JPEG or PDF file size:

1. Select **JPG** or **PDF** as the page format.
2. Right-click on the **JPG** or **PDF** icon.

A menu appears.

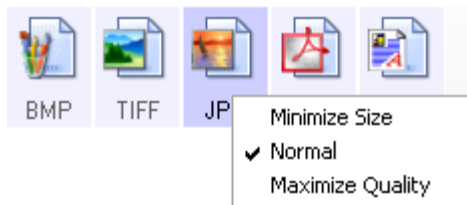

3. Choose the file size/image quality option for your scanned images.

Minimize Size—Smallest file size, lowest image quality.

Normal—Medium file size, some loss of image quality.

Maximum Quality—Largest file size, no loss of image quality.

Your selection pertains only to the button currently selected on the OneTouch Properties window. Other buttons that have JPG or PDF selected as the Page Format are not affected, so you can set the JPEG or PDF file size/image quality independently for each button.

4. Click **OK** or **Apply** on the OneTouch Properties window.

TEXT FORMATS

Selecting the text format option also selects OCR processing as an automatic step for scanning. Therefore, when you scan a document with the text format selected, the text portions of the document are automatically converted to editable text. See “Scanning with Optical Character Recognition (OCR)” on page 70.

Select a text format for documents with text or numbers, such as a business letter, report, or spreadsheet. The text format icon has several file formats available, depending on the Destination Application you select.

The specific file format is the file name extension on the text format icon.

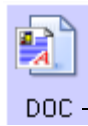

— The specific text format; this example is for Microsoft Word format (.doc).

As you select Destination Applications that are text applications, the text format icon changes to match the file type of the application. In some cases, the Destination Application supports several file types, and you can right-click on the icon to choose the particular file type for that application.

To select a file type for the text format:

1. Select the Destination Application.
2. Right-click on the text format icon.

A menu appears. The following figure shows samples for different formats.

Example menu for the DOC text format.

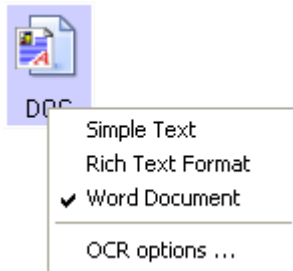

Example menu for the nPDF text format.

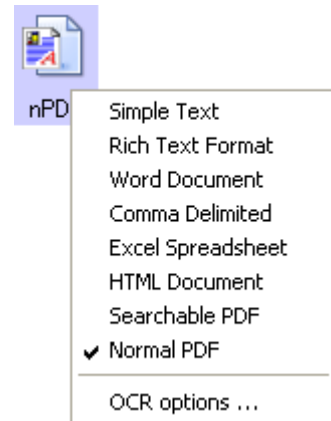

3. Choose the file type that you want for the text format.

Your selection of a file type pertains only to the button currently selected on the OneTouch Properties window. Other buttons that have a text option selected as the Page Format are not affected, so you can set the text file type independently for each button.



Simple Text—The .txt file format. Text with no formatting; used by the standard Microsoft Notepad application.



Rich Text Format—The .rtf file format. Text that retains formatting when converted. Available with Microsoft Wordpad and Word.



Word Document—The .doc file format used by Microsoft Word.



CSV

Comma Delimited—The .csv file format; used for database or spreadsheet data with fields separated by commas. When the document is converted into editable text by the OCR software, the fields are maintained so you can copy and paste them to a database or spreadsheet application.



XLS

Excel Spreadsheet—The .xls file format used by Microsoft Excel.



HTML

HTML Document—The .htm file format used to create web pages.



sPDF

Searchable PDF—The .sPDF file format used by Adobe Acrobat and OmniPage Pro 12. This format converts scanned text into PDF with text search and OCR capabilities. It is only available if you have installed OmniPage Pro 12 on your computer. See “Scanning with sPDF or nPDF and Searching for Text” on page 79 for details.



nPDF

Normal PDF—The .nPDF file format used by Adobe Acrobat and OmniPage Pro 12. This format also converts scanned text into PDF with text search and OCR capabilities, plus you can edit the text in an nPDF image if you have a PDF editing program. The nPDF format is also only available if you have installed OmniPage Pro 12 on your computer. See “Scanning with sPDF or nPDF and Searching for Text” on page 79 for details.

4. To change the OmniPage OCR settings, choose **OCR Options**. This menu selection is not available when the Destination Application is NotePad or Microsoft Internet Explorer.

The OCR Options provide a series of selections for the OCR feature when you scan text. This menu option is only available if you have installed OmniPage Pro 12 on your computer. See “Using OmniPage OCR Options” on page 71 for details.

Note that the OCR Options settings apply to all buttons. If you change them for one button, those changes apply to the other buttons as well.

5. Click **OK** or **Apply** on the OneTouch Properties window.

RENAMING A ONETOUCH BUTTON

The OneTouch buttons have names that identify their pre-set functions, such as OCR and PDF, but you can edit the names.

To change the button names:

1. Open the OneTouch Properties window.
2. Using the arrows, choose the button that you want to rename.
3. Select the name's text and type a new name.

Click the arrows to get to the button to rename, then select the name text.



Type a new name for the button.



4. Click **OK** or **Apply**.

The button is now renamed.

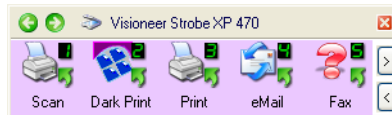

SELECTING OPTIONS FOR A BUTTON

The OneTouch Options determine the types of Destination Applications available for a button, as well as the location of the files of your scanned items.

To select options:

1. Open the OneTouch Properties window and click the **Options** tab.

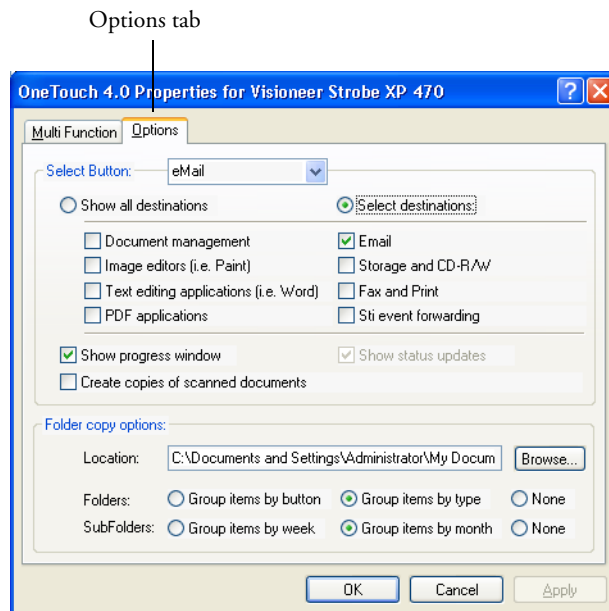

2. Click the menu arrow and choose the button for new options.
3. Select button options as described below.

Show All Destinations—This option selects all the Destination Application categories. The list of Destination Applications available for the selected button will include all the applications on your computer that fall into these categories. This is the default selection for Button 8. The list also includes printers and other devices connected to your computer so, for example, you can scan an item and have it printed immediately.

Select Destinations—Select this option to individually choose the types of applications to include in the list of Destination Applications. Check the boxes for the type of application to include.

- *Document Management* includes PaperPort and other applications for processing and keeping track of your scanned documents.
- *Image Editors* include Microsoft Paint and other drawing and graphics applications.
- *Text Editors* include Microsoft Word and WordPad, Microsoft Excel, and other word processing and spreadsheet applications. Select this option if you want OCR processing to convert your scanned documents to text that you can edit. See “Scanning with Optical Character Recognition (OCR)” on page 70 for more about OCR.
- *PDF* applications are for documents scanned to PDF format.
- *Email* includes Microsoft Outlook and other eMail applications. If you are using Microsoft Outlook or AOL Version 9.0 (or later) your scanned documents are added to a blank eMail message.
- *Storage and CD-R/W* is for either storing scanned documents in a folder, or sending them to a CD burner to create a CD containing the scanned documents. See “Transferring Scanned Documents to Storage” on page 89 and “Scan and Burn to a CD” on page 82 for details.
- *Fax and Print* is for sending your scanned documents directly to your printer or fax software for faxing.
- *Sti event forwarding* is for using another application’s interface for scanning. The OneTouch Event Forwarding dialog box appears so you can select which application to use to continue scanning. See “Scanning with Event Forwarding” on page 84 for details.

4. After selecting a new category of Destination Applications, click the **Multi Function** tab to see which ones are added to the list.

Show Progress Window—Select this option to display the progress window of the document(s) during scanning.

Create copies of scanned documents—Select this option if you want a copy of your scanned documents to be saved in the folder specified in the Folder Copy Options section. Note that these copies are in addition to the scanned files sent to the Destination Application. For example, if the Destination Application is Microsoft Word, two copies are saved—one in the Word folder and the other in the copy location folder. This option is not available if you have Document Management or Storage and CD-R/W selected as the Destination Application type.

Folder Copy Options—Type the name and path of the folder where you want to store copies of scanned documents, or click the **Browse** button and find the folder for the copies. Select the grouping option for the documents. The Group by button option groups the documents under the name of the OneTouch button. For example, if the button is named Printer, the documents are grouped under the name Printer. Group by type groups the scanned documents by the type of file, such as .doc or .jpg. If you also want to group them by date you can choose the week and month options.

5. Click **OK** to save the options for the selected button.

CREATING A NEW SCAN CONFIGURATION

The scan configurations are where you select the scanning resolution, brightness, mode (color, black&white, or grayscale), and a number of other settings.

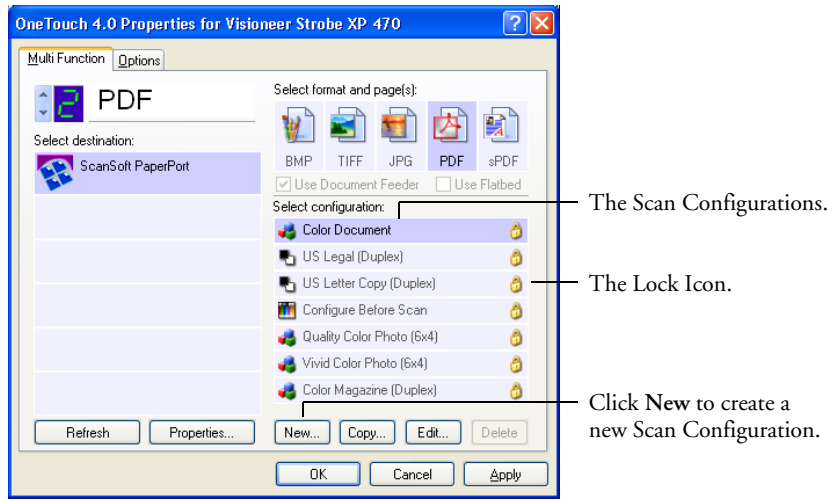

Note the lock icon on the preset configurations. Although you can unlock and edit the preset configurations, we recommend that you leave them locked, and only add new configurations. That way, you will always have the original factory-set configurations available.

To create a new configuration:

1. Open the OneTouch Properties window and make sure the **Multi Function** tab is selected.
2. Scroll through the applications in the Select Destination list and click the type of application for which you want to create a new scan configuration.

When you create a new scan configuration, it will appear for the buttons that are set for the same types of Destination Applications. For example, if you create a new configuration for a button that is set to show image editor applications, that new configuration also appears for any other buttons set for image editors, but not for

buttons set for text editing applications. Thus, you can create specific sets of scan configurations for specific functions and they appear only when appropriate.

3. Click the **New** button.

If you want to start from the settings of another configuration, select the configuration, then click the **Copy** button.

If the **Scan Settings** tab is not selected, click it.

4. On the Scan Configuration Properties dialog box, type a name.

TIP: If you're going to set up the new configuration to scan duplex (two-sided), include that in the name, such as "Scan for Dark Print (Duplex)," to remind you that it is a duplex scan.

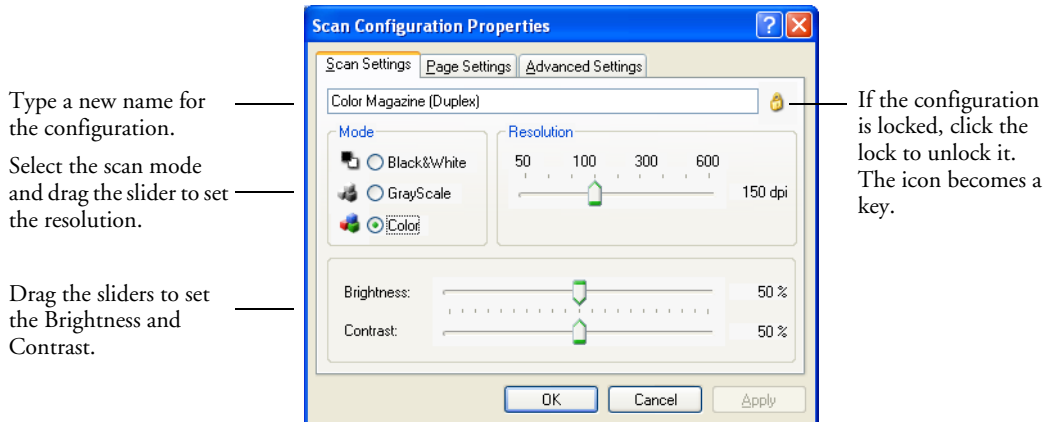

Type a new name for the configuration.

Select the scan mode and drag the slider to set the resolution.

Drag the sliders to set the Brightness and Contrast.

If the configuration is locked, click the lock to unlock it. The icon becomes a key.

Note: If you select a printer or other device in the Select Destinations list, the dialog box may have an additional Device Settings tab for setting specific options for the particular device.

5. Select scan settings for the new scan configuration.

Mode—Select a scanning mode:

- **Black&White** to scan in black and white. For example, letters and memos are usually scanned in black and white. This scan mode produces the smallest file size.

- **GrayScale** to scan items such as documents containing drawings or black and white photographs. The scanning produces an image of up to 256 shades of gray.
- **Color** to scan color photographs and other color items. Color scans have the largest file size.

Resolution—Drag the slider to the right or left to adjust the dots per inch (dpi) of the resolution. The maximum resolution is 600 dpi; the minimum is 50 dpi. The higher the dpi setting, the sharper and clearer the scanned image. However, higher dpi settings take longer to scan and produce larger files for the scanned images.

Brightness and Contrast—Sometimes an item is scanned with the brightness and contrast set too light or too dark. For example, a note written with a light pencil may need to be scanned darker to improve legibility.

Brightness refers to the lightness or darkness of the image.

Contrast is the range between the darkest and lightest portions of the image. The greater the contrast, the more difference between the lighter and darker shades in the image.

Drag the sliders to the right or left to adjust the brightness and contrast of the scanned image. The Contrast setting does not apply to the Black&White mode.

6. If you want to lock the configuration, click the lock icon to change it from a key to a lock.

7. Click the **Page Settings** tab to select page settings.

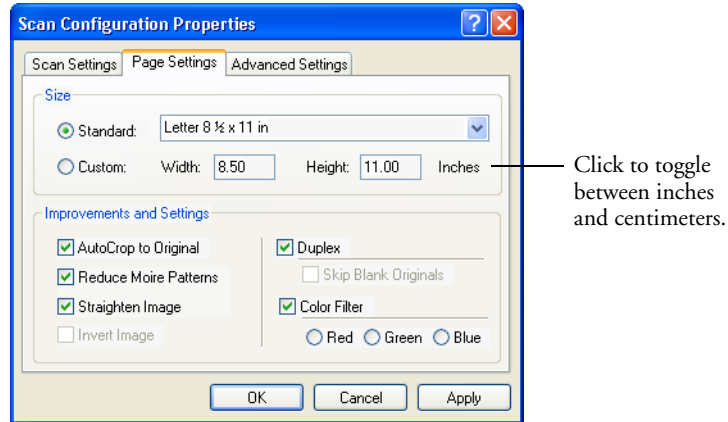

Size—Click **Standard**, click the menu arrow and choose a page size from the list, or click **Custom** and enter the horizontal and vertical page dimensions in the boxes. The maximum size is 8.5" x 14". The units of measurement can be inches or centimeters. Click the name of the units, inches or centimeters, to toggle between them.

Improvements and Settings—Only the options that apply to the selected Destination Application are available.

- **AutoCrop to Original**—Select this option to let the scanner automatically determine the size of the item being scanned. For example, if you scan a 5 by 7 inch photo, the scanner will determine the size of the photo.

When using the AutoCrop to Original option, always use the paper guides on the scanner so the page is not skewed. Skewed pages may not scan properly.

For single-sided scans, the scan area is the size of the image. For double-sided scans, the scan area is the size of the larger of the two areas on the front and back of the page.

- **Straighten Image**—Select this option to let the scanner automatically determine if a page is skewed, and then straighten its image. The scanner detects page edges and can sense when the page is fed through at an angle. However, if the page is fed through

at too great an angle, the image may not scan correctly. In that case, re-scan the page using the paper guides to feed the paper in straight.

- **Reduce Moire Patterns**—Moire patterns are wavy, rippled lines that sometimes appear on the scanned images of photographs or illustrations, particularly newspaper and magazine illustrations. Selecting **Reduce Moire Patterns** will limit or eliminate moire patterns in the scanned image. This option is only available for the Grayscale or Color Mode at 200dpi or less.
- **Invert Image**—Only available for Black&White Mode, this option reverses the black and whites of an image.

Original Image



Inverted Image



- **Duplex**—Scan both sides of the page. If this option is not selected, the scanner will scan the front side of the page only.

Note: Because you can set Duplex and Simplex for the OneTouch buttons, there could be a conflict when you press the Simplex or Duplex button on the scanner. Regardless of the OneTouch setting, the scanner button always takes precedence. In other words, even if the LED number on the scanner has a setting for Duplex, when you press the Simplex scanner button the scanner scans in Simplex mode, and vice versa.

- **Skip Blank Originals**—Skips pages that are completely blank. Typically you use this option when you will scan a stack of two-sided pages which have a number of blank sides. This option is only available for Duplex scanning.

- **Color Filter**—Color filter is the ability of your scanner to automatically remove a color from a scanned item. For example, if you are scanning a letter with a red watermark, you can choose to filter out the red so the scanned letter just shows the text and not the red watermark. Color filter applies to Black&White or Grayscale Mode.

The original with a red watermark over black text.

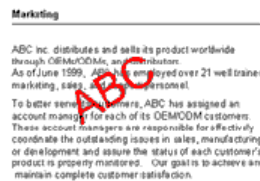

The scanned item with the red filtered out.

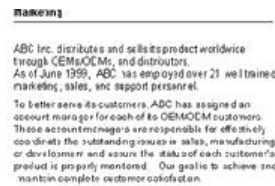

8. Click the **Advanced Settings** tab.

The options of the Advanced Settings tab are for the Color or Grayscale scanning mode.

Saturation is the strength or purity of a color, hue is the color your eyes see as reflected from the image, and gamma controls the brightness of the midtones of the color.

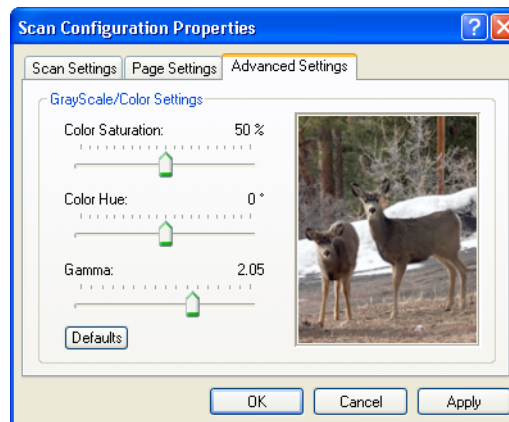

9. Drag the sliders to the left and right to change the color settings. As you do, the image changes to show the effects of the new settings.

10. Click **OK** to save the new configuration.

It will now appear in the list of Scan Configurations on the OneTouch Properties window for the appropriate Destination applications.

THE DEVICE SETTINGS TAB

A Device Settings tab appears on the Scan Configurations dialog box when your selected Destination Application sends the scanned image to a printer, fax application, or other device. You use the options on the Device Settings tab to select settings for the device.

1. Click on the **Device Settings** tab.

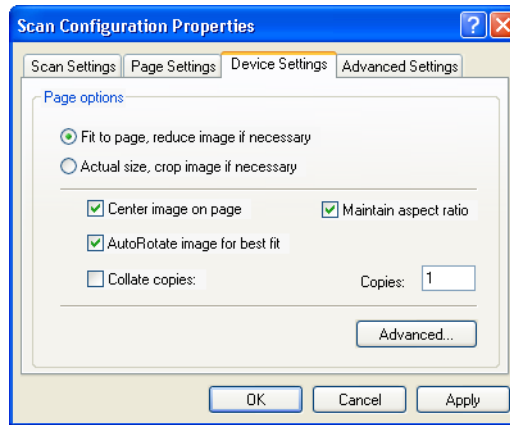

Fit to page, reduce image if necessary—If the scanned image is too big to be printed or faxed on a single page, the image will automatically be reduced to fit the page.

Actual size, crop image if necessary—If the scanned image is too big to be printed or faxed on a single page, the image will automatically be cropped around its edges to fit on the page.

Center image on page—The image will be printed in the center of the page instead of at the top right corner.

Maintain aspect ratio—The aspect ratio is the length-to-width relationship of the image’s dimensions. Select this option so the image’s relative proportions remain constant.

AutoRotate image for best fit—If the image is a Landscape format and the device is printing in the Portrait mode, or vice versa, rotate the image to fit on the page.

Collate copies—If you’re printing more than one page, collate the copies. Enter the number of copies in the **Copies** box.

Advanced—Click to see additional settings for the device. The dialog that appears is specific to the device. For example, if the device is your printer, the dialog box is your printer’s setup settings.

2. Click **OK** or **Apply**.

THE STORAGE OPTIONS TAB (ARCHIVE)

A Storage Options tab appears on the Scan Configurations dialog box when the selected Destination Application is set as Transfer to Storage. You use the options on this tab to select where you want to save your scanned items for storage when scanning with that particular Scan Configuration. Button 7 is set as the default Archive button for scanning to storage, with Transfer to Storage as the destination. So if you want to have the Scan Configuration apply to Button 7, switch to it first before creating the new Scan Configuration.

Note: The selections you make using the Storage Options tab override the storage options that apply to the Storage Properties. This means that you can create separate Scan Configurations to store scanned items at various locations in addition to the main location set by the Storage Properties. See “Storage Properties” on page 45 and “Transferring Scanned Documents to Storage” on page 89 for more details.

1. Click on the **Storage Options** tab.

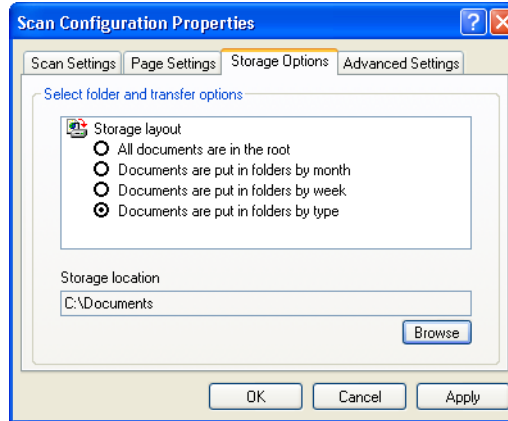

2. Click the Storage Layout options you want.

All documents are in the root—The scanned documents are saved in the root of the folder specified in the Storage Location.

Documents are put into folders by month, week, or type—Folders are created based on your selection (month, week, or type) and the scanned documents are saved in those folders. New folders are created for each month and week so you can keep track of when you scanned the documents.

3. Click the **Browse** button to specify the location to store the scanned documents, or type a location directly into the box.
4. Click **OK** or **Apply**.

EDITING OR DELETING SCAN CONFIGURATIONS

To edit or delete a scan configuration:

1. Open the OneTouch Properties window.
2. Select the scan configuration you want to edit or delete.

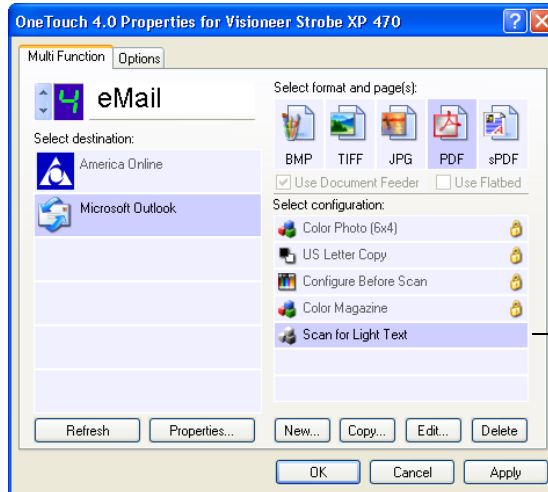

3. To delete the configuration, click the **Delete** button.

- To edit the configuration, click the **Edit** button.

The Scan Configuration Properties dialog box opens for that configuration.

To edit or delete a configuration, it must first be unlocked. Click the Lock icon to unlock the configuration. Clicking it toggles between locking and unlocking the configuration.

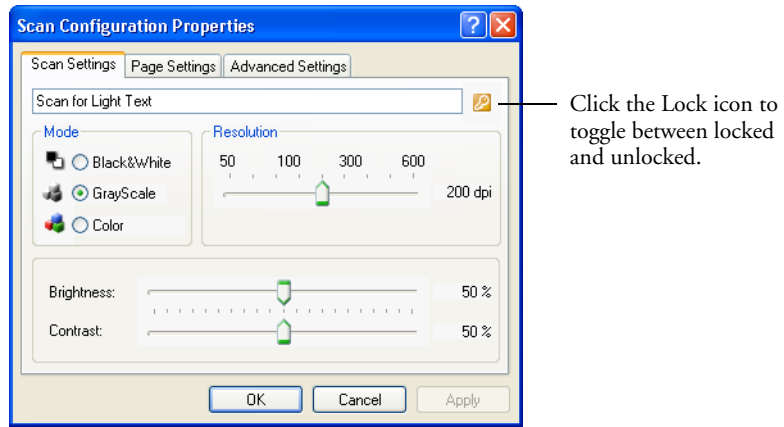

- Edit the settings and click **OK**.
- Click **OK** to close the dialog box.

CONFIGURING BEFORE SCANNING

You can manually configure the scan settings before beginning the scanning process. In that case, you select Configure Before Scan as the Scan Setting. When you press a scan button, one of the scanning interfaces appears for you to set the scanning options.

To configure before scanning:

- Open the OneTouch Properties window.
- Using the arrows, choose the button that you want to set to configure before scanning.

3. Select the scan configuration **Configure Before Scan**.

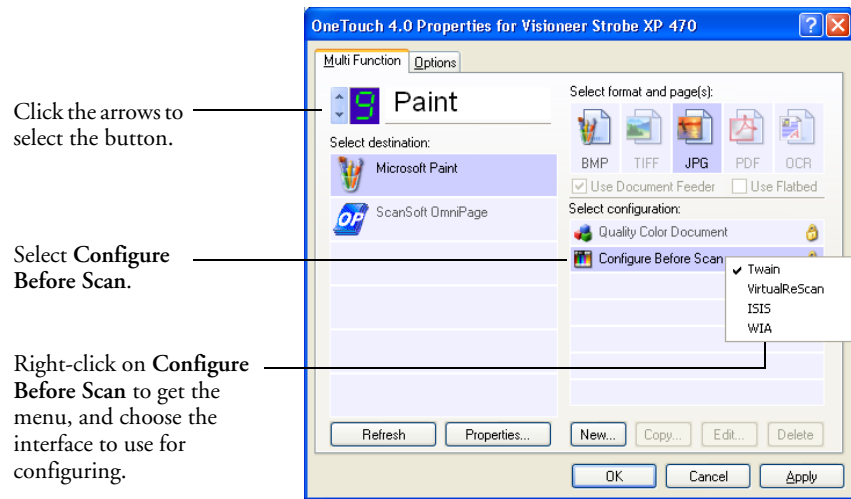

4. Right-click on **Configure Before Scan** and choose an interface to use for configuring before scanning.

TWAIN—The Basic Interface or Advanced Interface appears for you to configure the scanning. See “Scanning from the Basic Interface or Advanced Interface” on page 96.

VirtualReScan—The Kofax VRS TWAIN interface appears for you to configure the scanning.

ISIS—The ISIS Scan interface appears for you to configure the scanning.

WIA—The Windows Image Acquisition Interface (WIA) appears for you to configure the scanning. See “Scanning with the Windows Image Acquisition” on page 119.

Note: The WIA option is only available if your computer is running Microsoft Windows XP or Me.

5. Click **OK** or **Apply** on the OneTouch Properties window.

SCANNING WITH OPTICAL CHARACTER RECOGNITION (OCR)

Optical Character Recognition (OCR) is like a printer in reverse. Instead of printing what's on the screen onto paper, OCR converts text and numbers on a scanned page into editable text and numbers. You can then work with the text and numbers to edit, spellcheck, change font or type size, sort, calculate, and so forth.

The OCR process is automatic when the format you select for the Destination Application is a Text format, such as DOC, TXT, XLS, or RTF. In other words, when you scan a page and send it to a text application, the words and numbers on the scanned page are automatically converted to editable text so you can then work with them in the application.

The OmniPage 12 software that you received with your Visioneer Strobe XP 470 scanner offers additional options for OCR. See the next section, "Using OmniPage OCR Options" on page 71 for details.

Note: OneTouch Button 6 is preset as your OCR button. But you can also set up any other button to scan and OCR the text.

To scan with OCR:

1. Use any of the following methods:
 - To scan using the buttons on the scanner, press the Destination Selector until the LED is at 6, then press the **Simplex** or **Duplex** button.

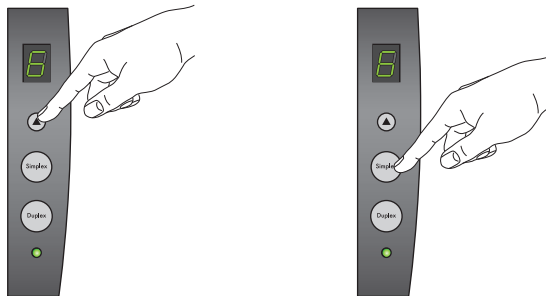



- To scan from the OneTouch Button Panel, click the OneTouch icon in the Windows system Tray, click the arrows to see Button 6, then click Button 6.

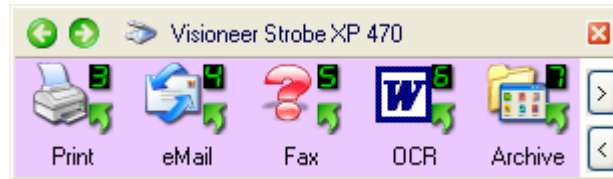

Click the arrows until Button 6 is on the panel, then click Button 6.

- To scan from the OneTouch Properties window, select a Destination Application that has one of the Text formats.
2. Now scan the document.

Your scanned pages appear in the Destination Application with their text ready for editing and other text processing.

Note: OCR scanning is also for spreadsheets so you can work in Microsoft Excel (or other spreadsheet application) with the figures and text from the original spreadsheets.

USING OMNIPAGE OCR OPTIONS

The OmniPage OCR Options are only available if you have installed OmniPage Pro 12 on your computer. OmniPage Pro 12 is on the Disc 2 CD that you received with your scanner in case you haven't installed it yet.

Note: OmniPage OCR options apply globally to all the OneTouch buttons that perform OCR. For example, Button 6 is set by default to OCR text, but Button 8 is not. If you reconfigure Button 8 to also OCR text, the OCR options you select for Button 8 will also apply to Button 6.

To select OmniPage OCR options:

1. Open the OneTouch Properties window.
2. Using the arrows, choose a button that has Destination Applications that use the text format as their file type.
3. Select the Destination Application to get one of the text format file types as the page format.
4. Right-click on the page format icon to see the menu.
5. Choose **OCR Options** from the menu.

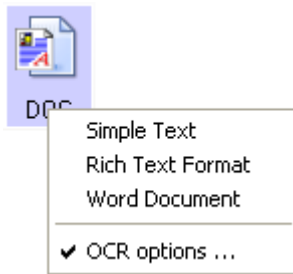

The OmniPage OCR Options window opens with the **OCR** tab selected.

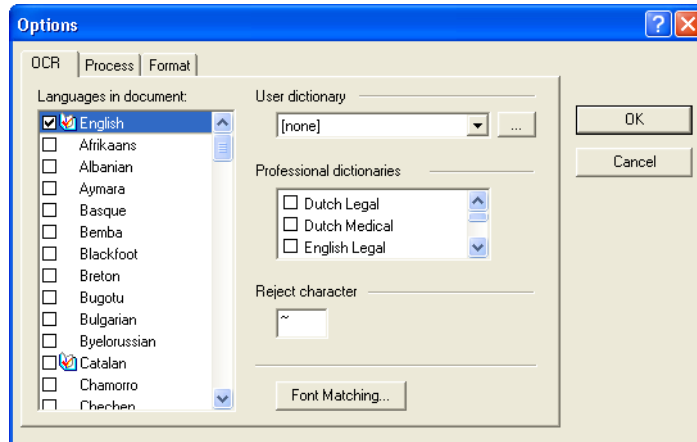

6. Choose the options you want from the OCR window.

Languages in Document—Select the language(s) in the documents to be scanned. These are the languages that will be recognized during the OCR process. For faster and more reliable language recognition, select only the languages in the document.

The languages at the top of the list are your recent choices. Below that the languages are in alphabetical order. Type a letter to jump to one of the languages in the list.



The dictionary icon indicates a language with dictionary support available. The dictionary is consulted to help in the OCR process. It can also offer suggestions during proofing.

User Dictionary—A user dictionary is your personal dictionary with words that you want the OCR proofreading process to recognize as legitimate words. For example, if you scan documents with highly technical terms not found in typical dictionaries, you can add them to your personal dictionary. You can also add names that you expect to be in the documents too. That way, when the OCR process proofreads the text, names will not be considered misspelled words. You can create multiple user dictionaries.

Click the menu arrow and select a user dictionary from the list. Any Microsoft Word user dictionaries detected on your computer system are also listed. A dictionary named Custom is your default Word dictionary.



To create a user dictionary, click the button next to the menu arrow. Click **New**, type a name for the dictionary, and click **OK**. Click **Close** and then choose your new dictionary from the list. It will be used during the OCR process. You add words to a dictionary during the proofreading process. To turn on the proofreading process for your scanned documents, see the OmniPage Pro 12 documentation.

Professional Dictionaries—These are legal and medical dictionaries containing highly specialized words and phrases. The options are: Dutch Legal, Dutch Medical, English Legal, English Medical, French Legal, French Medical, German Legal, and German Medical. Click the checkbox next to a dictionary name to select it.

Reject Character—This is the character that the OCR process inserts for an unrecognizable text character. For example, if the OCR process cannot recognize the J in REJECT, and ~ is the reject character, the word would appear as RE~ECT in your document. The ~ is the default reject character.

Type the character you want to use in the Reject character box. Try to choose a character that will not appear in your documents.

Font Matching—Your computer system usually has a number of fonts available for the OCR process to use to recognize text. However, not all of the fonts may be selected for the OCR process. Using Font Matching you can select the fonts on your computer that match the fonts in your documents.

Click the **Font Matching** button to see the Font Matching dialog box.

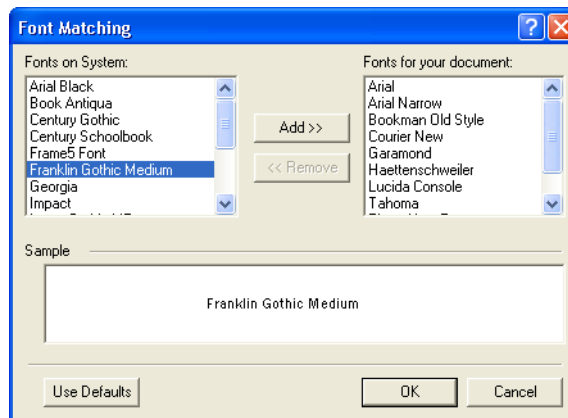

The list on the left are the fonts available on your computer system. The list on the right are the fonts that will be used by the OCR process to recognize the text in your documents. If possible, the list of **Fonts for your document** should include all the fonts in the

documents you plan to scan. To add new fonts to that list, select a font in the **Fonts on System** list and click **Add**. Note that when you select a font, a sample appears in the text box so you can compare it with the fonts in your document to see if that's the right font. To remove a font, select it and click **Remove**. To return the lists to their defaults, click **Use Defaults**. Click **OK** when you're finished.

7. Click the **Process** tab and choose the options from the Process window.

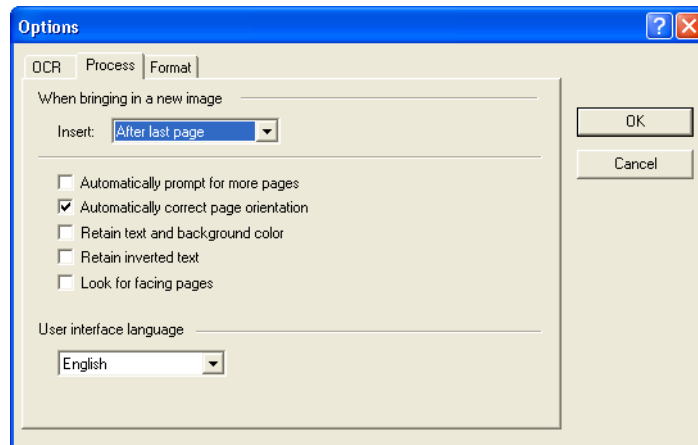

When bringing in a new image—Click the menu arrow and select where you want new pages added to your current document. The choices are **After last page**, **After current page**, **Before current page**, and **Before first page**.

Automatically prompt for more pages—Select this option if the document is too big to fit into the scanner's paper guide.

Automatically correct page orientation—Select this option to have the OCR process check orientation and automatically rotate an improperly oriented page image by 90, 180 or 270 degrees prior to recognition. All pages are automatically straightened (de-skewed) if necessary.

Retain text and background color—If your document contains colored text or backgrounds, select this option to have them detected and displayed in the text editing application you have selected. The colored text and backgrounds will also be available for export. Deselect this option if you want color pictures in the document but do not want colored text and backgrounds. You can change the color of texts and backgrounds in the OmniPage Pro 12 Text Editor.

Retain inverted text—Inverted text is white or pale letters on a black or dark background. Select this option to retain inverted text, deselect it to have inverted text transformed to normal text of black text on a white background.

Look for facing pages—Select this option if you want to scan two facing pages of an open book in one step, and then to recognize and store them as two separate pages (as if they had come from two separate scannings).

User interface language—English is the interface language.

8. Click the **Format** tab and choose the options you want from the Format window.

Note that as you select formats, the image changes to represent the selection so you can see, at a glance, what the layout will look like.

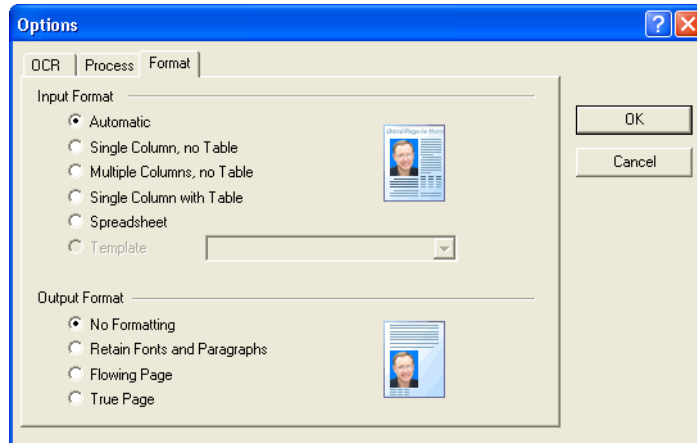

Automatic—Choose this option to let the OCR process determine the layout of the pages. It is the fastest type of format processing. Typically you select this option when the document has different or unknown types of layouts, pages with multiple columns and a table, or pages containing more than one table. The OCR process will then determine if text is in columns, an item is a graphic or text, and tables are present.

Single Column no Table—Choose this option if the document contains only one column of text and no tables. Business letters are normally in this form. You can also use this option for documents with words or numbers in columns if you do not want them placed in a table or decolumnized or treated as separate columns.

Multiple Columns, no Table—Choose this option if some document pages contain text in columns and you want it kept in separate columns, similar to the original layout. If table-like data is encountered, it is placed in columns, not in a gridded table.

Single Column with Table—Choose this option if your document contains only one column of text and a table. The table will be placed in a grid in the text editing application you have selected. You can later specify whether to export it in a grid or as tab-separated text columns.

Spreadsheet—Choose this option if the entire document consists of a table that you want to export to a spreadsheet program, or have treated as a table. No flowing text or graphics zones will be detected.

Template—If you created a zone template in OmniPage Pro 12, choose a zone template file to have its background value, zones and zone properties applied to all OCR scanned pages from now on.

No Formatting (NF)—The document will be plain text, decolumnized and left-aligned in a single font and font size. You can export plain text to nearly all file types and target applications, and graphics, tables and bullets can be retained. When exporting to Text or Unicode file types, graphics and tables are not supported.

Retain Fonts and Paragraphs (RFP)—This output format retains the font and paragraph styling, including graphics and tables without columnized text. This output format is available for nearly all file types.

Flowing Page (FP)—This format keeps the original layout of the pages, including columns. This is done wherever possible with column and indent settings, but not with text boxes or frames. Text will then flow from one column to the other, which does not happen when text boxes are present.

True Page (TP)—This output format keeps the original layout of the pages, including columns. This is done with text, picture and table boxes and frames. True page is offered only for target applications capable of handling the formatting. True Page formatting is the only choice for XML export and for all PDF export, except to the file type “PDF Edited”.

9. When you're finished selecting the OCR options, click **OK** on the **Options** window.

These options will now apply to the OCR processing when you select any scan button with a text format as the page format.

SCANNING WITH sPDF OR nPDF AND SEARCHING FOR TEXT

Searchable PDF (sPDF) and Normal PDF (nPDF) are special forms of an Adobe PDF file. sPDF converts scanned text into the PDF format with text search and OCR capabilities. nPDF has those same features, plus you can edit the text in an nPDF image if you have a PDF editing program. The two PDF formats can also produce images with different image quality, so you may want to experiment with them to determine which is better for your scanned documents. sPDF and nPDF are only available as page format options if you have installed OmniPage Pro 12 on your computer.

To scan with sPDF or nPDF:

1. Open the OneTouch Properties window.
2. Using the arrows, choose a OneTouch button to use for the sPDF or nPDF scanning.
3. Select a Destination Application that uses a text format as the page format.
4. Right-click on the text format icon.

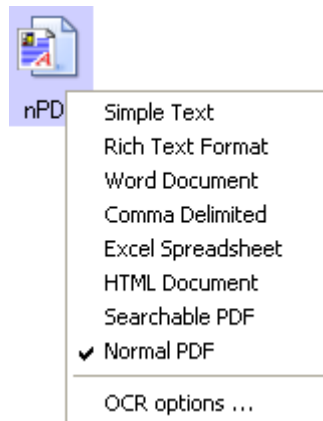

5. Choose the **Searchable PDF** or **Normal PDF** option for the page format.

Note: Not all Destination Applications have the sPDF and nPDF options. Microsoft Word, for example, does not have them as scanning options.

The settings for the button (button 8 in this example) now show your page format selection.

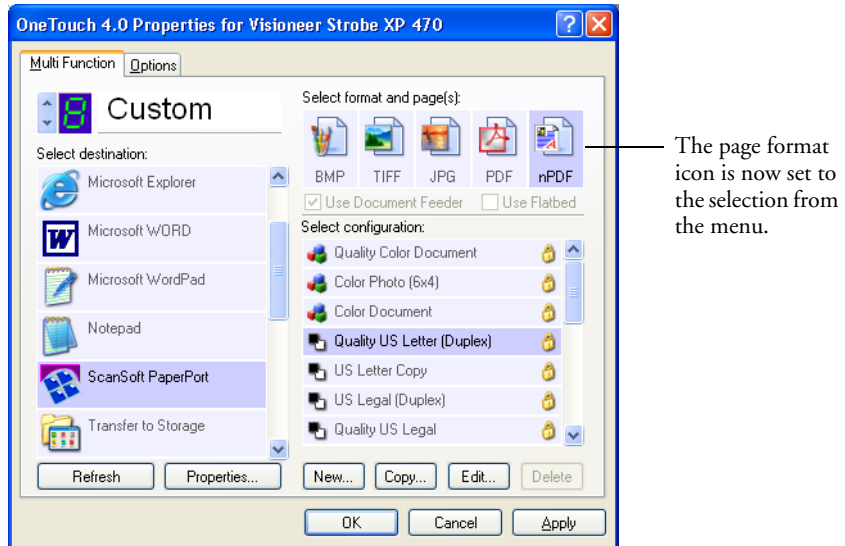

6. Choose a Scan Configuration.
7. Click **Apply** or **OK**.
8. Now scan with that button and the scanned document will be in the sPDF or nPDF format that was selected for the button.

Note: The Transfer to Storage selection for a Destination Application also has the sPDF and nPDF options. That means you can scan and store items directly to a server in these formats.

9. To search for the text, open Adobe Acrobat Reader or Adobe Acrobat.
10. From the Adobe Acrobat **File** menu choose **Open**, and open the file you just scanned.

11. From the Adobe Acrobat **Edit** menu choose **Find**.

The Find dialog box appears.

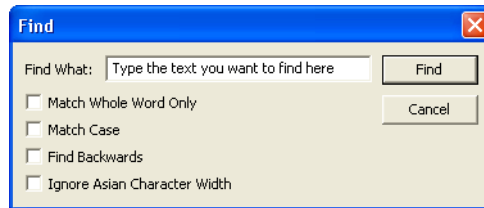

12. Enter the text you want to find, and click the **Find** button.

See the Adobe Acrobat user manual for more about finding text in a PDF file, or about editing PDF text.

SCAN AND BURN TO A CD

If you have a CD burner attached to your computer, you can scan directly from your Visioneer Strobe XP 470 scanner onto a CD. This feature is available only on computers running Windows XP.

To scan and burn to a CD:

1. Put a blank CD into your computer's CD Drive.
2. Open the OneTouch Properties window.
3. Using the arrows, choose a button to use for scanning and burning to a CD.
4. Select **Burn to CD** as the Destination Application.

The Burn to CD Destination Application is only available if you have a CD burner attached to your computer, but you do not need to have a CD in the burner to select the destination.

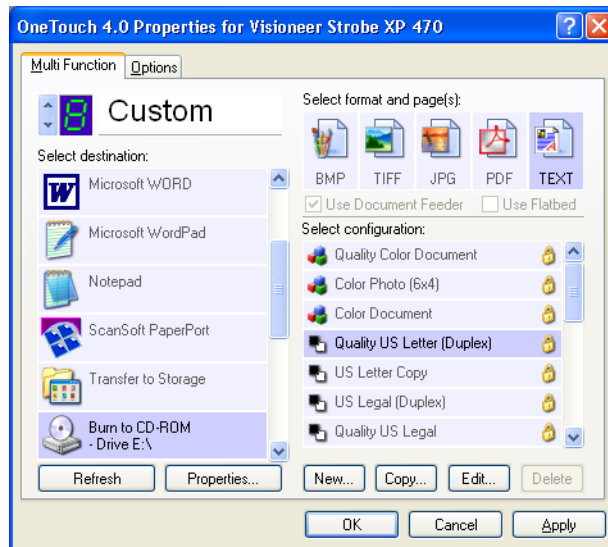

5. Choose a Page Format and a Scan Configuration.
6. Click **Apply** or **OK**.

7. Now start scanning using the button you selected to use to scan and burn to CD.

When scanning is finished, a bubble message on the screen tells you that files are waiting to be burned to the CD.

8. On the OneTouch window, make sure that the **Burn to CD** Destination Application is still selected and click the **Properties** button.

The OneTouch 4.0 Link Properties window appears,

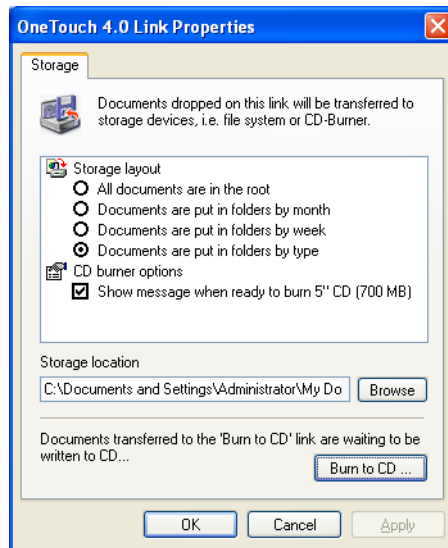

9. Make sure a CD is in the CD burner.
10. Click the **Burn to CD** button.

The CD burner begins and your scanned documents are written to the CD.

SCANNING WITH EVENT FORWARDING

If you want to specify an application to use for scanning at the start of the process, you can use event forwarding. The scanner will feed in the first page, but will then stop until you select the application to use. After you select the application, its interface will open and you can use it to continue with the scanning.

To scan with event forwarding:

1. Open the OneTouch Properties window.
2. Using the arrows, choose a button to use for the event forwarding.
3. Select **Still Image Client** as the Destination Application.

Note that you cannot choose a page format for this option because the actual destination application is not selected until after the scanner feeds in the first page of your document.

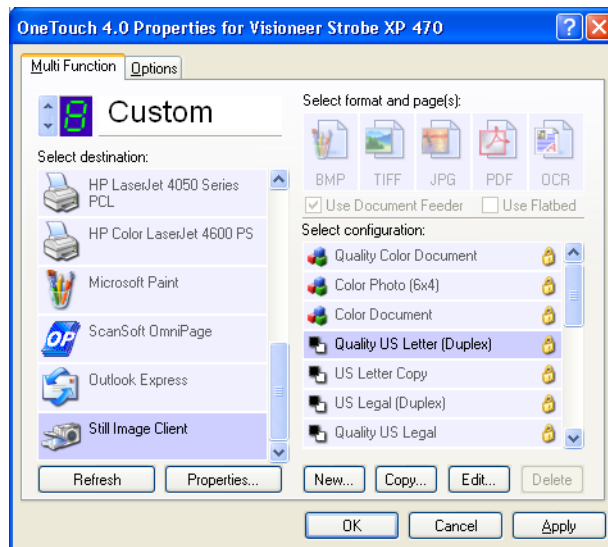

4. Choose a Scan Configuration.
5. Click **Apply** or **OK**.

6. Start scanning using the button you selected for event forwarding.
A dialog box appears for you to select the application to use for scanning.

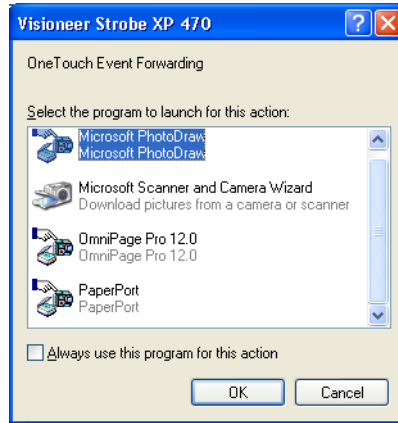

7. Select the application in the box and click **OK**.
Now the application you selected opens and you can continue the scanning from that application's TWAIN interface.

CREATING AN HTML WEB PAGE FROM YOUR SCANNED DOCUMENTS

If you scan a document, whether a single page or multiple pages, you can have the pages converted directly to html formatted pages for posting directly to your web site. Those pages are then viewable by visitors to your web site without the need for any internet plug-ins or other special processing. This is, essentially, from your scanner to a web-ready format in one automatic step.

To scan and create an HTML web page:

1. Open the OneTouch Properties window.
2. Using the arrows, choose Button 6, or any other button that has Microsoft Explorer as one of its Destination Applications.
3. Select **Microsoft Explorer** as the Destination Application.
4. Choose **HTML** as the Page Format.

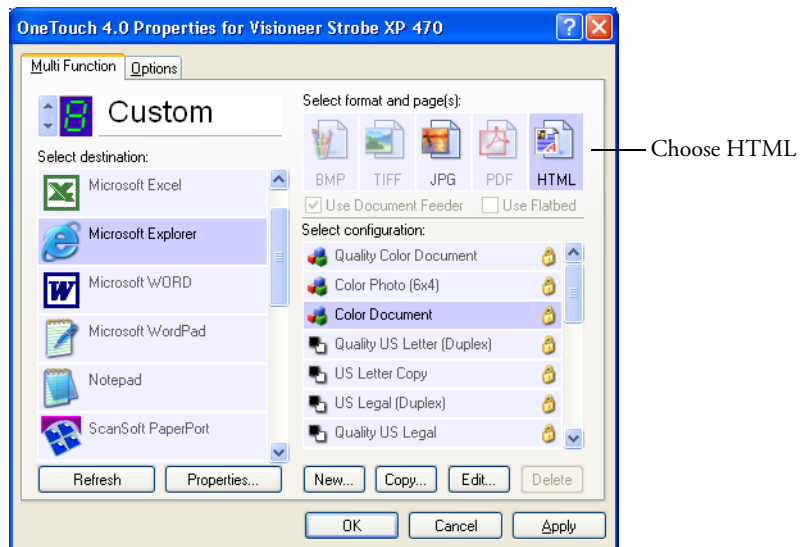

5. Choose a Scan Configuration.
6. Click **Apply** or **OK**.

7. Now on the OneTouch Button Panel, click Button 6 (or if you used another button, click it).

When scanning is finished, the document is first converted to editable text using the OCR process, and then is converted into an HTML format. Microsoft Internet Explorer then opens showing your converted page.

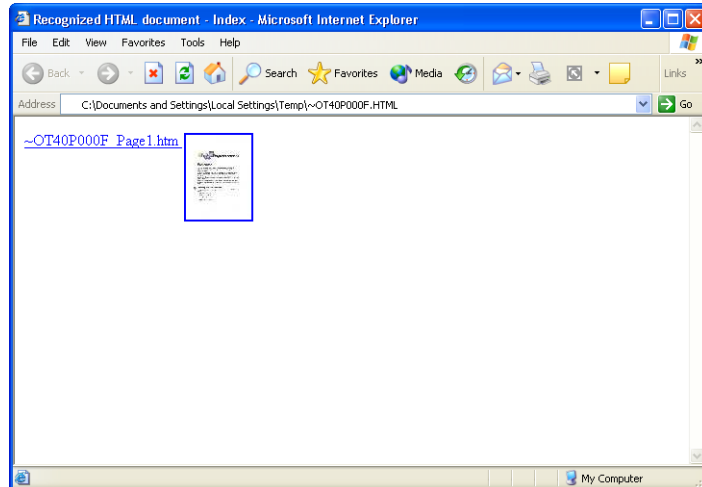

8. Choose **Save As** from the Internet Explorer **File** menu, give the page a name, and save it in the location you use for your web page files.

You may also want to write down the address shown in the Address bar to make sure you'll know where to find your new HTML page later on.

If you want to see what the page will look like on your web site, click on it.

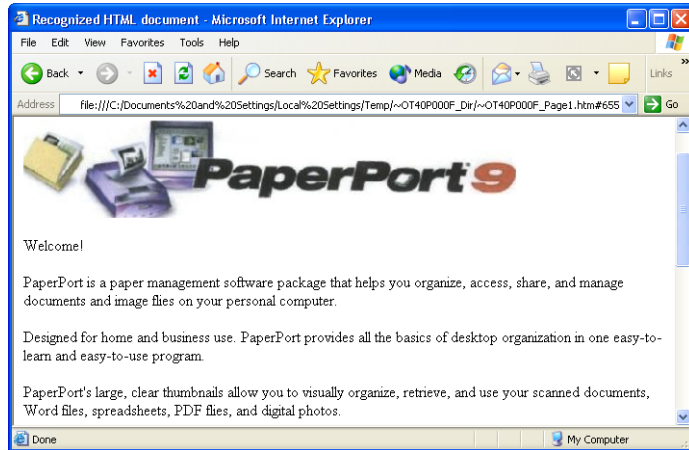

9. You can now use Microsoft Internet Explorer or other application to post the document to your web page as you would any other HTML page.

TRANSFERRING SCANNED DOCUMENTS TO STORAGE

With the Transfer to Storage scanning process, you can scan documents and save them in a folder in one step. The process is ideal for archiving documents without having to manually save or process them in any other way. If you choose a text format for the file format, the documents are also automatically converted by the OCR process into editable text and numbers before being stored.

Note: OneTouch Button 7 is preset as your Archive button. But you can also set up any other button to scan to Archive the text.



1. To scan using the buttons on the scanner, press the Destination Selector until the LED is at 7, then press the **Simplex** or **Duplex** button.
2. To scan from the OneTouch Button Panel, click the OneTouch icon in the Windows system Tray, click the arrows to see Button 7, then click Button 7.

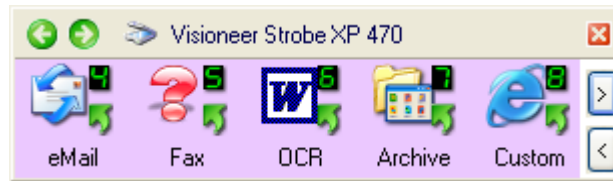

Click the arrows until Button 7 is on the panel, then click Button 7.

Your scanned pages are stored in the location that you specified on the OneTouch 4.0 Link Properties window.

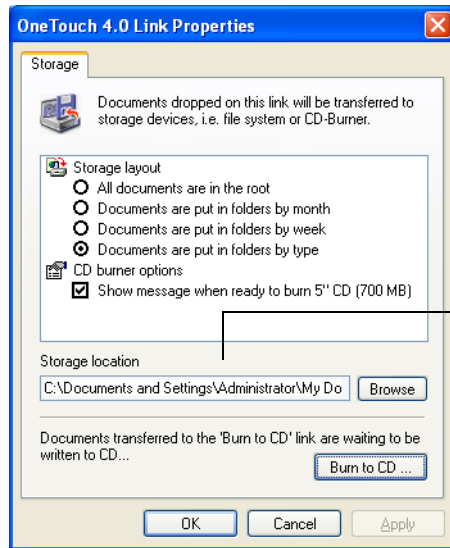

Your scanned documents will be stored at this location.

To Use OCR Before Transferring to Storage

If the documents you want to transfer to storage are text documents or spreadsheets, you can have them converted by the OCR process prior to being stored.

1. Open the OneTouch Properties window.
2. Using the arrows, choose Button 7, or any other button if it is set up with Transfer to Storage as one of its Destination Applications.
3. Choose a text format as the file format.

- Right-click on the text format icon and choose the file format for the scanned documents.

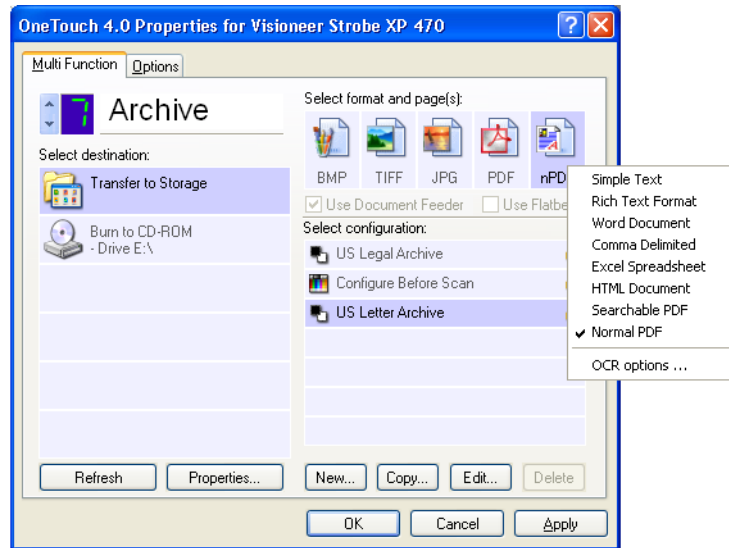

- Choose a Scan Configuration.
- Click **Apply** or **OK**.
- Now start scanning using Button 7 (or other button you set up for archiving).

When scanning is finished, the documents are saved in the text file format and in the location you specified.

CHECKING THE HARDWARE AND SETTING THE LAMP POWER SAVE MODE

1. Right-click on the OneTouch icon and choose **Show Hardware** from the pop-up menu.

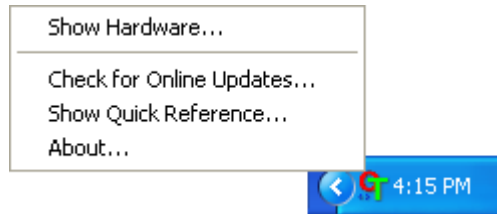

You can also click the scanner icon at the top of the OneTouch Button Panel.



If the Hardware View of the panel is open you can also right-click on the XP 470 icon.

The Hardware Properties dialog box appears and shows information about your Vioneer Strobe XP 470 scanner.

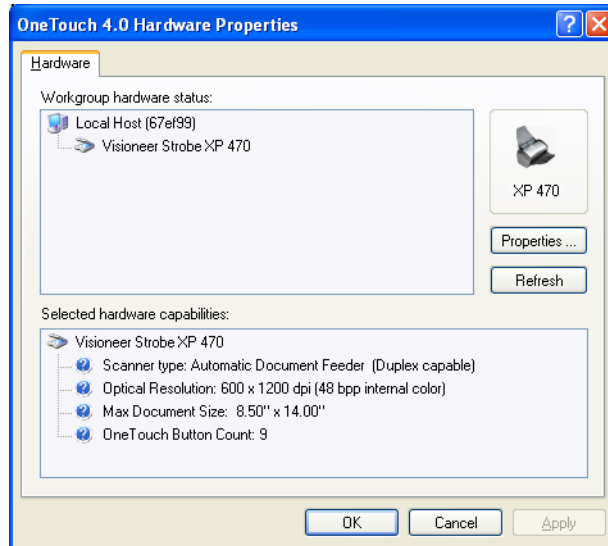

2. Click the **Properties** button.

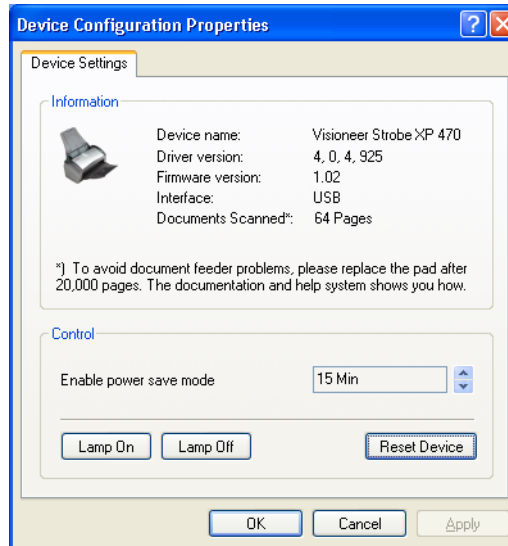

Your scanner has a built-in power saving feature that is set to power down after 15 minutes of idle time. You can change the time before the scanner powers down, from 10 minutes to a maximum of 10 hours.

3. Click the arrows for the Lamp timeout setting and choose a time setting.

To turn the lamp on and off manually without turning off power to the scanner, click the **Lamp On** or **Lamp Off** buttons.

To return the scanner to its factory settings, click **Reset Device**.

4. Click **OK** to save the changes and close the dialog box.

Scanning from PaperPort

Instead of using the scanner buttons or the OneTouch Button Panel to scan, you can scan from PaperPort.

You scan from PaperPort using the Basic Interface, Advanced Interface, or the Windows Image Acquisition (WIA). See “Scanning with the Windows Image Acquisition” on page 119 to scan using the Windows Image Acquisition.

The Basic Interface and Advanced Interface use the TWAIN standard for scanning. TWAIN is a widely recognized method that computers use to receive images from scanners, digital cameras, and other digital devices. Many other graphics and imaging applications also comply with the TWAIN standard, so you can use your scanner with those applications too.

Note: When scanning, the Basic Interface or Advanced Interface opens right away (without opening PaperPort first) if the button you’re using to scan is set to **Configure Before Scan**, and the selected option is **TWAIN**.

SCANNING FROM THE BASIC INTERFACE OR ADVANCED INTERFACE

The instructions in this section are for scanning from the PaperPort Desktop using the Basic Interface or Advanced Interface.

To scan an item from PaperPort:

1. Start **ScanSoft PaperPort 9.0**.

The PaperPort Desktop opens.

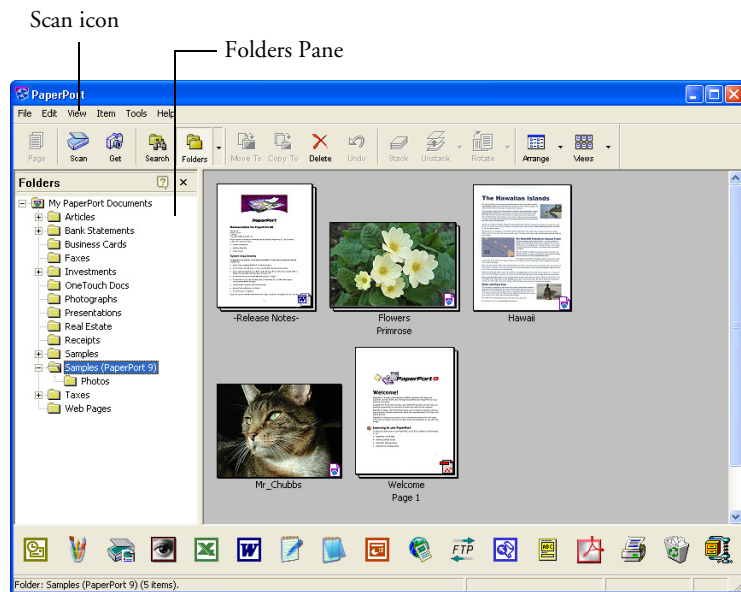

2. Click the **Scan** icon on the PaperPort command bar.

The Folders pane (which shows folders for organizing your scanned images) is replaced by the Scan pane.

Scan pane

Choose Visioneer Strobe XP 470 from here

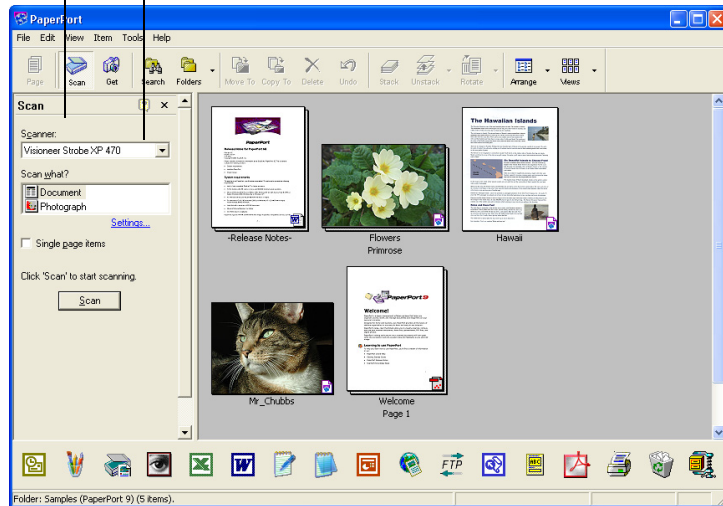

1. From the Scanner list, choose **Visioneer Strobe XP 470**.
2. In the “Scan what?” section, choose to scan a **Document** or **Photograph**.

If you want to change the format of the scanned item’s file name or file type before you start scanning, click **Settings**. The default file type for documents is .pdf and the default for photographs is .jpg.

3. Use the **Single page items** check box as follows:
 - When the check box is selected, all pages in the automatic document feeder are scanned and placed as single pages on the PaperPort desktop.
 - When the check box is not selected, all pages in the automatic document feeder are scanned, but not placed on the PaperPort desktop until you indicate the scanning job is finished by clicking **Done** on the **PaperPort-Scan** window.

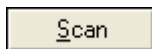

4. Click the **Scan** button on the Scan pane.

The Basic Interface opens and you’re ready to start scanning.

5. If you haven't put the document into the scanner's paper guide, do it now.

Note: If you used the Advanced Interface the last time you scanned from PaperPort, it will open instead.

Note: You can also open the Basic Interface or Advanced Interface from the PaperPort ScanDirect application.

SELECTING SETTINGS

Clicking the Settings option on the PaperPort Scan panel displays the Settings dialog box where you can change the naming of scanned items and their file type.

To select Settings:

1. Click **Settings** on the Scan Pane before clicking the Scan button.

The Settings dialog box appears.

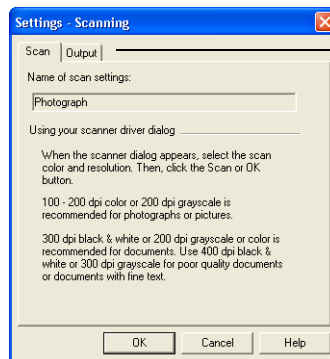

Click the Output tab to see setting options.

When the Scan tab is selected, as shown above, the dialog box shows information about the scan.

2. Click the **Output** tab.

The Settings dialog box now has options for setting the name of scanned items, and their file type.

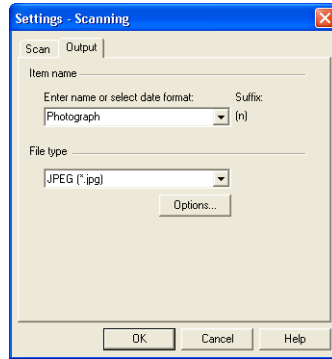

- **Enter name or select date format**—You have two basic options for the naming of scanned items: a text name, or a date.

To give scanned items a text name, type the name in the box. For example, to name your scanned items *Photograph*, type the word *Photograph* in the box. From then on, each scanned item is named *Photograph* and is numbered sequentially, *Photograph* (1), *Photograph* (2), and so on.

To name each item by the date when it is scanned, click the menu arrow and choose one of the date formats, such as *March 4, 2001*. From then on each scanned item is named on the date when it is scanned, and numbered sequentially, *May 23, 2003* (1), *May 23, 2003* (2), and so on.

- **File type**—Click the menu arrow and choose the file type for your scanned items, such as *.jpg*, *.pdf*, or *.bmp*. Your scanned items are then converted to that file type and placed on the PaperPort Desktop. The small icon on the bottom right corner of the PaperPort thumbnails indicates the file type you selected.



This icon indicates the PDF format.

If you select JPEG or PDF as the file type, you can also click the **Options** button to select image quality options.

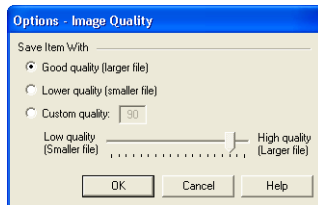

These options offer choices for the balance between image quality and file size. The higher the quality of the image, the larger the file size, and the lower the quality the smaller the size. For example, for images on your web site, you may accept less image quality and a smaller file size so images load faster on your web pages. The **Good Quality** and **Lower Quality** options produce reasonably good images. To select your own option, click **Custom** and drag the slider. Click **OK**.

SCANNING FROM THE BASIC INTERFACE

The Basic Interface can scan a preview of the image so you can adjust its appearance before scanning the final image. After adjusting the appearance, you click the Scan button on the Basic Interface (not on the scanner) to scan the item.

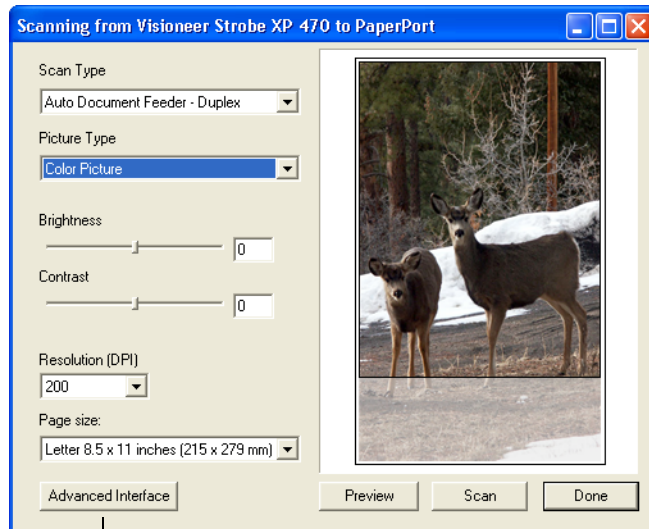

Click the Advanced Interface button if you would rather scan with the Advanced Interface.

1. From the **Scan Type** menu, choose the option to scan Simplex (one-sided) or Duplex (two-sided).
2. Choose the color, grayscale, or black and white option from the **Picture Type** menu.

Note: If you want to preview the document before scanning, make sure only one page is loaded into the scanner.

Preview

3. Click the **Preview** button.

The scanner scans the item and displays a preview image. You can now use the options on the Basic Interface to adjust the image.

Note: If you want to preview for a stack of pages, use one of the pages as a test page and load it into the scanner. Click the Preview button and adjust the scanner settings. Then replace the page on the stack at its original position and load the stack into the scanner. Then just click the Scan button.

4. Adjust the brightness, contrast, and resolution until the picture is what you want.

You can also change the picture type again, for example, from color to grayscale.
5. To preview the item with the new settings, place the document into the ADF again and click the **Preview** button again on the Basic Interface.
6. When you are satisfied with the preview image, place the document into the ADF again and click **Scan**.
7. When you're finished scanning items, click **Done** to close the Basic Interface.

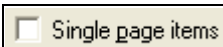

If the **Single page items** check box is selected on the PaperPort desktop, the item appears as a thumbnail on the desktop.

If the **Single page items** check box is not selected, thumbnails do not appear until you indicate the scanning job is finished.

See "The Single Page Items Check Box" on page 104.

8. On the PaperPort Scan message box, click **Done**.

When scanning is complete, thumbnail images appear on the PaperPort Desktop

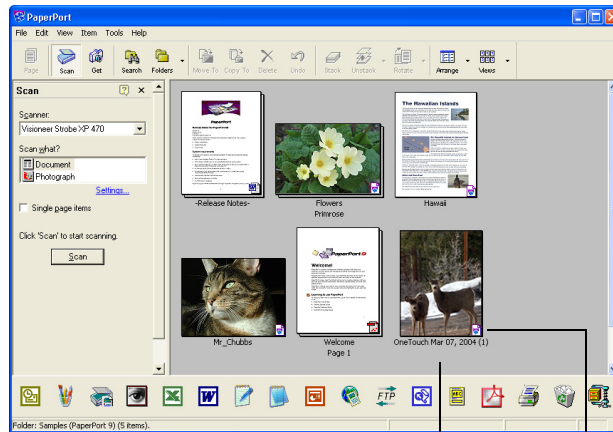

A thumbnail image of the scanned item appears on the PaperPort desktop

The small icon represents the file format, in this case the PaperPort format

ON THE PAPERPORT DESKTOP

- Unless you changed it with the Settings option, the name of the scanned image is the day, date, and number of scanned items that day. For example, the second item scanned on a day is followed by a (2), the third by a (3) and so on. To change a name, click it to select its text and type a new name.
- The thumbnail images of the stack of documents has “go to page arrows” at their top right corners so you can click to flip through the pages in the stack. The page counter underneath the thumbnail name shows which page you’re viewing.
- The small icon at the bottom right corner of the thumbnail image indicates the file format of the scanned item.

THE SINGLE PAGE ITEMS CHECK BOX

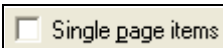

The Single page items check box (on the PaperPort Desktop Scan Pane) provides the option to add additional items to a scanning job. If the check box is selected, scanned items immediately appear on the PaperPort desktop. If the check box is not selected (this is the default), the following message box appears when you close the Basic Interface.

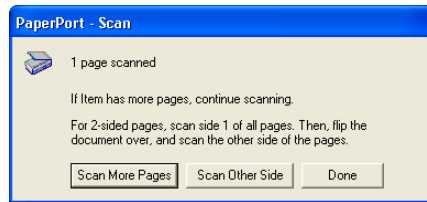

- Click **Scan More Pages** to scan additional pages and add them to the stack of items placed on the PaperPort desktop.
- Click **Scan Other Side** to reload and scan the other side of previously scanned pages. This option is only available once.
- Click **Done** if you are finished scanning. The scanned items are placed on the PaperPort desktop.

To learn more about the PaperPort software please see the *ScanSoft PaperPort User's Guide* on the Installation CD.

GETTING HELP WITH THE PAPERPORT SOFTWARE

The PaperPort software includes a complete set of help topics that answer questions about each feature of the software. To open the Help Topics window, press the **F1** key or choose **PaperPort Help** from the **Help** menu.

You can also refer also to the *PaperPort Getting Started Guide* and *PaperPort User's Guide* on the CD.

SCANNING FROM THE ADVANCED INTERFACE

The Advanced Interface has more options for scanning.

1. Open the Basic Interface as described in the section “To scan an item from PaperPort:” on page 96.
2. Click the **Advanced Interface** button on the Basic Interface.



The Advanced Interface appears.

Choose Simplex (one-sided) or Duplex (two-sided) from this menu.

Click an icon to select a configuration—Color, Grey Scale, or Black&White. Clicking the “+” sign in front of Custom shows Custom’s scan settings.

Click a setting in the list to change it. The setting’s options appear on the right side of the Advanced Interface where you can make changes if necessary.

Check the Scan Info to make sure your computer has sufficient space for the image. Warning icons on this box appear if your computer does not have enough space for the scanned image’s file.

If you don’t need all the features of the Advanced Interface, click Basic Interface to return to it.

Click Preview to view the image in the window.

When you are satisfied with the scan settings, click Scan.

Click Done to close the Advanced Interface.

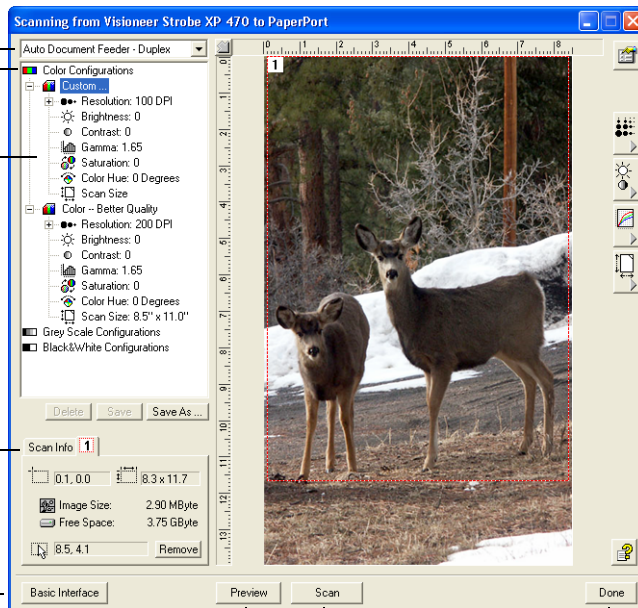

1. From the menu at the top left panel, select whether you want to scan a Simplex (one-sided) or Duplex (two-sided) document.
2. Click one of the icons to select a configuration.

For example, select Color Configurations and then select Custom to scan a color item with the preset Custom scan settings.

The configuration settings appear as a list. Click the + (plus) sign to see the full list. Click the - (minus) sign to collapse the list.

- **Black&White** is for letters, memos, pen and ink drawings, and other black and white material. This setting produces the smallest file size for scanned items.
 - **GrayScale** scans the image using up to 256 true shades of gray. Use this setting to scan black and white photographs and other higher quality black and white images. You can also scan a color photo with this setting to turn its colors into gray shades. The file size is about one third the size of a color scan.
 - **Color** scans the image in full color. Use this setting to scan color photographs and other color images. The file size is the largest of the image type options.
3. Click the **Preview** button to preview the image before scanning.
 4. Review the image to determine if adjustments are needed.
 5. To adjust a setting, click the setting in the list on the left below the selected configuration.

A panel opens on the right side of the Advanced Interface for the selected setting. Select new options on that panel. See “Adjusting the Image with the Advanced Interface” on page 108 for details on changing scan settings.

6. (optional) To preview the image again, put the document back into the scanner's automatic document feeder, and click the **Preview** button again. Readjust the settings if necessary.
7. When you're satisfied with the image, load all the documents into the paper guide and click the **Scan** button.

A window opens during scanning and shows the progress of the scan.

8. When you're finished scanning items, click **Done** to close the Advanced Interface.

When scanning is finished, a thumbnail of the scanned image appears on the PaperPort desktop. If you're scanning multiple pages, they appear as PaperPort stacks. The default setting is to scan multiple items and save them as stacks. That setting is controlled by the Single Page Items check box.

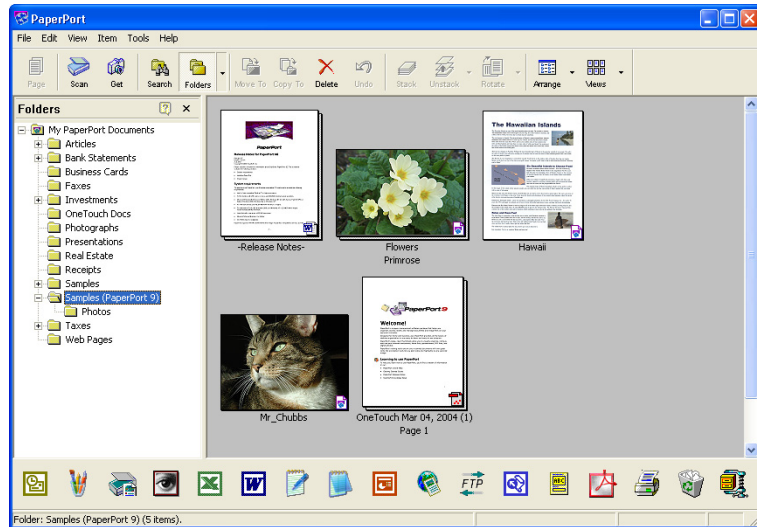

To Cancel scanning while it's in progress, click the **Cancel** button on the progress window.

9. If the **Single page items** check box is selected on the PaperPort desktop, the item appears as a thumbnail on the desktop.

If the **Single page items** check box is not selected, thumbnails do not appear until you indicate the scanning job is finished.

See "The Single Page Items Check Box" on page 104.

10. Use the PaperPort software to work with the image.

ADJUSTING THE IMAGE WITH THE ADVANCED INTERFACE

You can adjust the scan settings on the Advanced Interface to produce the best possible image for the documents you're scanning.

To adjust a setting:

1. On the left side of the Advanced Interface, select a configuration, for example, Color Configurations.
2. Click a setting in the list of settings, or click its corresponding button on the right side of the Advanced Interface.

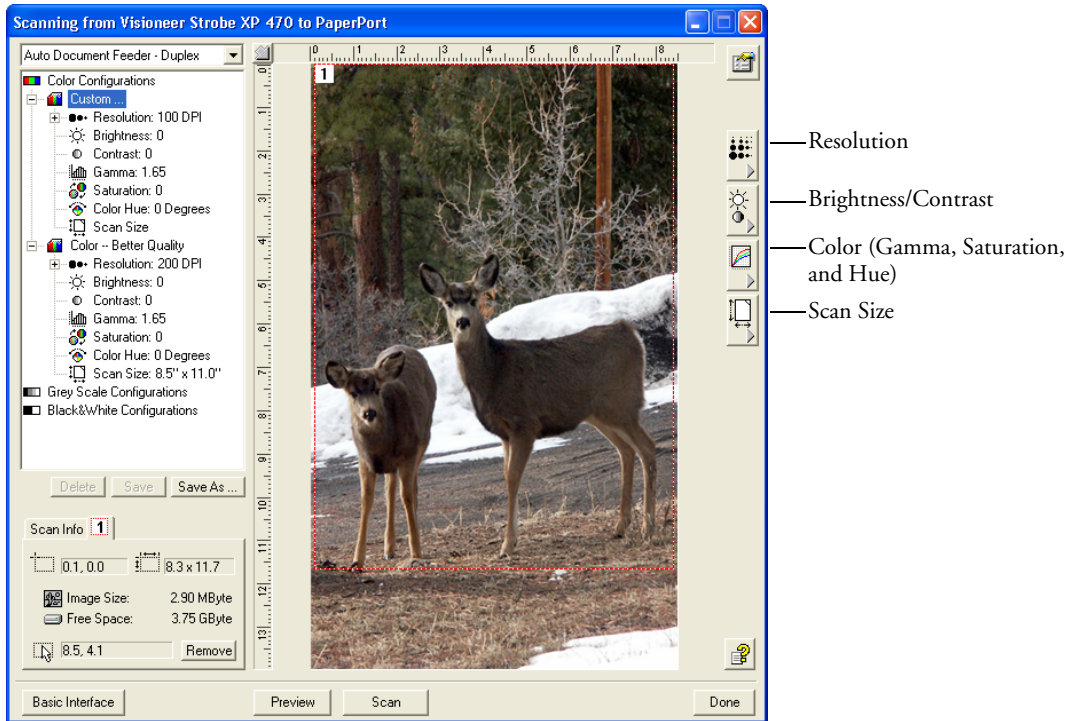

Note: The list of scan settings for a configuration applies only to that type of configuration. For example, the Black&White Configuration does not have a setting for adjusting the Color Hue.

The following figure shows an example of the Advanced Interface if you click the Resolution setting in the list, or click the Resolution button.

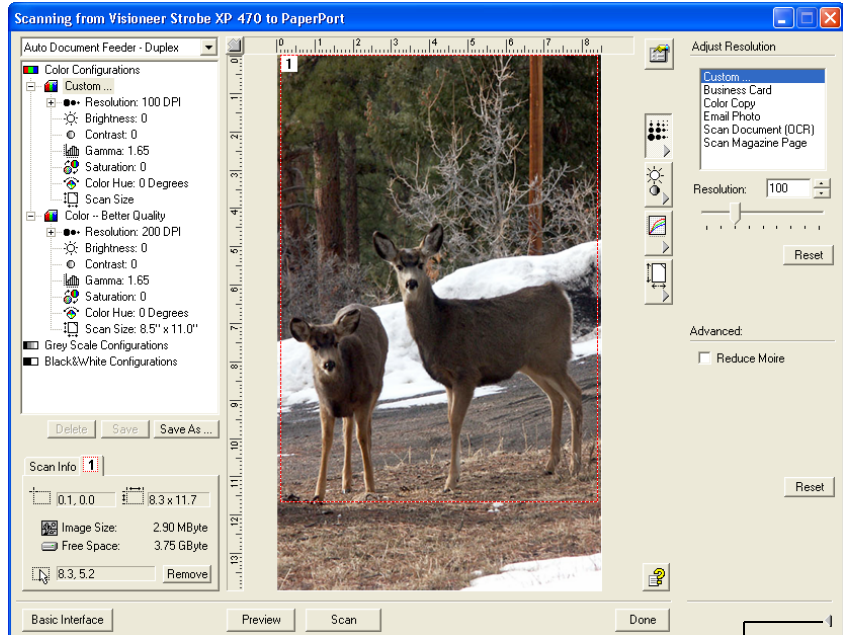

Click to close the settings panel

Note: The information in the scan settings list and the options you select on the various settings panels are interactive. As you change the settings on the panel, the numbers in the list on the left also change.

ADJUSTING THE RESOLUTION

Resolution determines the amount of detail you can see in the scanned image. The resolution setting for a scan is in dots-per-inch (dpi). The higher the resolution, the finer the details. However, higher dpi settings also take longer to scan and produce larger files sizes. Usually the higher resolution settings are used for precision work, such as photographs or fine artwork.

The following figure shows the resolution options.

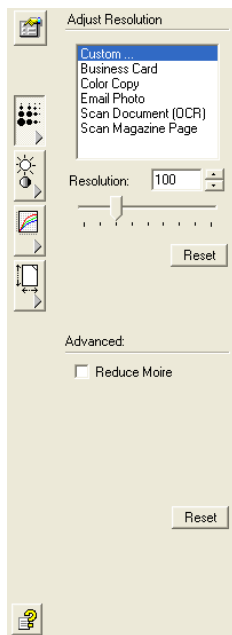

Note: The location of various buttons on the panels may be slightly different on your Advanced Interface window. The appearance of the window depends on your monitor's screen resolution.

To adjust the resolution:

1. To use one of the preset resolutions for typical scanned items, click one of the options in the list.

For example, to set the resolution for scanning a business card, select Business Card. That setting is preset to read small print on a typical business card.

2. To set the resolution manually, drag the **Resolution** slider to the left to decrease the resolution or to the right to increase it.

You can also type a number directly into the resolution setting box, or click the up and down arrows to increase or decrease the setting. The resolution settings on your Visioneer Strobe XP 470 scanner range from 50 dpi to 600 dpi.

3. Click **Reset** to return the resolution to its original setting.

The resolution panel also includes an advanced setting for Moire patterns. Moire patterns are wavy, rippled lines that sometimes appear on the scanned images of photographs or illustrations, particularly newspaper and magazine illustrations. To scan the image and limit or eliminate moire patterns, select the **Reduce Moire** option. This option is only available from 50 to 300 dpi.

ADJUSTING THE BRIGHTNESS AND CONTRAST

Sometimes an item is scanned with the brightness and contrast set to be too light or too dark. For example, a note written with a light pencil may need to be scanned darker to improve legibility.

The following figure shows the brightness and contrast options. Contrast is only available for Color and Gray Scale configurations.



To adjust the brightness and contrast:

1. Drag the **Brightness** slider to the left to make the item darker or to the right to make the item lighter.
2. Drag the **Contrast** slider to the left to decrease the contrast or to the right to increase the contrast.

You can also type a number directly into the brightness or contrast setting boxes, or click the up and down arrows next to the box to increase or decrease the setting.

3. Click **Reset** to return the settings to their original numbers

ADJUSTING GAMMA, SATURATION, AND COLOR HUE

If you're using the Color Configuration to scan, you can adjust a group of color settings. Gamma controls the brightness of the color midtones. Saturation is the strength or purity of a color and hue is the color your eyes see as reflected from the image.

The following figure shows the color options.

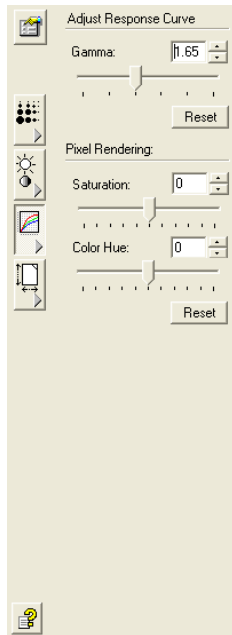

To adjust the color settings:

1. Drag the **Gamma**, **Saturation**, and **Color Hue** sliders to the left to decrease the settings or to the right to increase the settings.

You can also type a number directly into the setting boxes, or click the up and down arrows next to the boxes.

2. Click **Reset** to return the settings to their original numbers.

ADJUSTING INPUT SIZE

You can scan documents up to 8.5" x 14", but you can select other scan sizes, or adjust the input size to scan only specific sections of an image. For example, if you're scanning a photograph and want to focus on one section, adjusting the input size removes the rest of the photograph from the final scanned image.

The following figure shows the input size options.

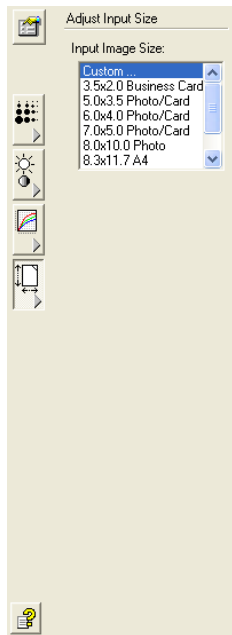

To set the image size:

1. Select the image size from the menu.

The dotted outline shows the selected area in the image.

The following figure shows an example of a manually selected area.

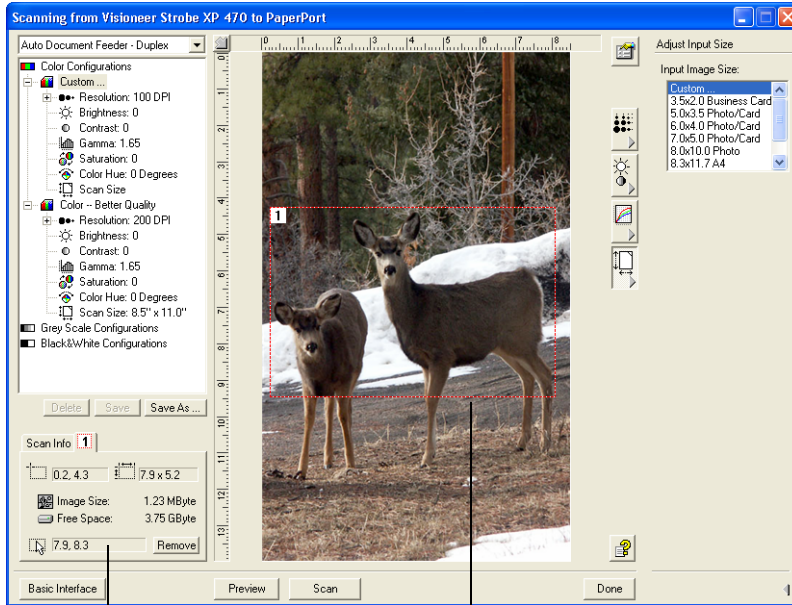

The Scan Info box shows the size and position of the area.

The selected scan area.

This is the image that appears on the PaperPort desktop when scanning is finished.



1. You can now move or resize the outline to select the specific area you want to scan.
2. To move the dotted outline, put the pointer in the selected area and drag the mouse.
3. To resize the selected area, put the pointer on a dotted line and drag it.

Note that as you drag a dotted line, the menu selection for the image size changes to **Custom** to indicate you are customizing the size.

The Scan Info box on the lower left portion of the Advanced Interface shows the information for the new area.

4. If the dotted line is not exactly where you want it, put the pointer on the line and drag the mouse.
5. If you want to remove the selected area and start over, click **Remove** on the Scan Info box.

Note: Clicking **Remove** causes the entire 8.5" x 14" area to be selected.

THE RULER UNITS

The ruler around the edges of the image help you precisely position a custom sized image. You can change the ruler units to suit the type of measurements you want.

To set the ruler units:



1. Click the **Ruler Units** button.

The ruler units across the top and down the side of the window cycle through centimeters, inches, and pixels.

THE SCAN INFO BOX

The following figure shows the information on the Scan Info box:

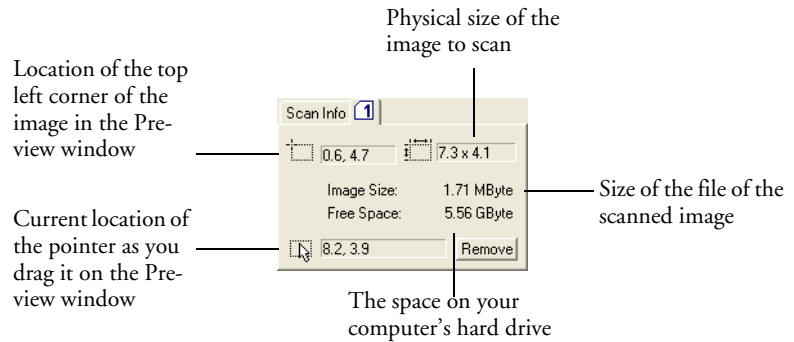

CREATING A NEW ADVANCED INTERFACE PROFILE

You cannot change the settings of the preset profiles in the Advanced Interface. However you can create new profiles and save them for future use.

To create a new profile:

1. On the Advanced Interface, select one of the preset profiles, for example, Black&White Configurations/Custom.
2. Adjust the settings as required and then click the **Save As** button.

The Save Profile dialog box opens.

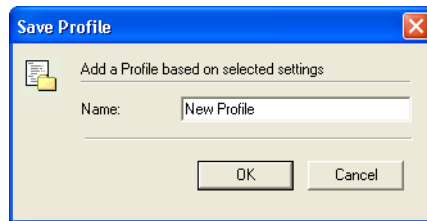

3. Type a name for the new profile and click **OK**. The name must be at least two characters long.

Your new profile is added to the configuration list.

To change or delete a profile you created:

1. Select your profile from the configuration list.
2. Make changes to the profile as needed, and then click **Save**.
3. If you want to delete the selected profile, click **Delete**.

DISPLAY THE DEVICE CONFIGURATION



1. Click the **Device Configuration** button.

The Device configuration window shows the information about your scanner.

See the section “Checking the Hardware and Setting the Lamp Power Save Mode” on page 92 for more information about the device settings.

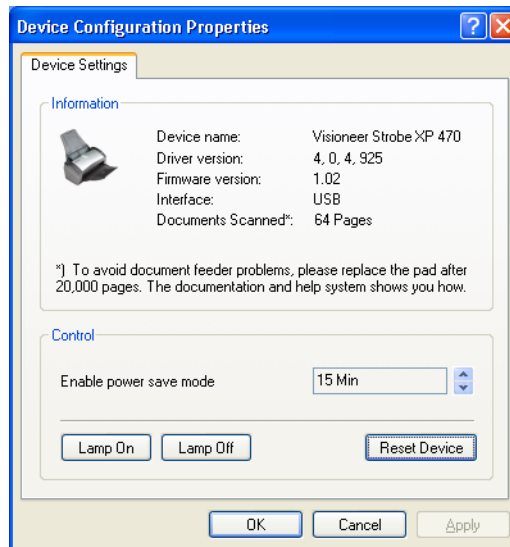

SCANNING WITH THE WINDOWS IMAGE ACQUISITION

Microsoft Windows includes its own set of options for acquiring images from scanners, digital cameras, and other digital devices. Windows Image Acquisition (WIA) options as described below.

Note: Scanning with the Windows Image Acquisition (WIA) is only available if your computer is running Windows XP or Me.

To scan an item:

1. On the Windows taskbar, click **Start**, point to **All Programs**, point to **ScanSoft PaperPort 9.0**, and then click **PaperPort**.

The PaperPort desktop opens.



2. Click the **Scan** icon on the PaperPort command bar.

The Folders pane is replaced by the Scan pane.

Scan pane

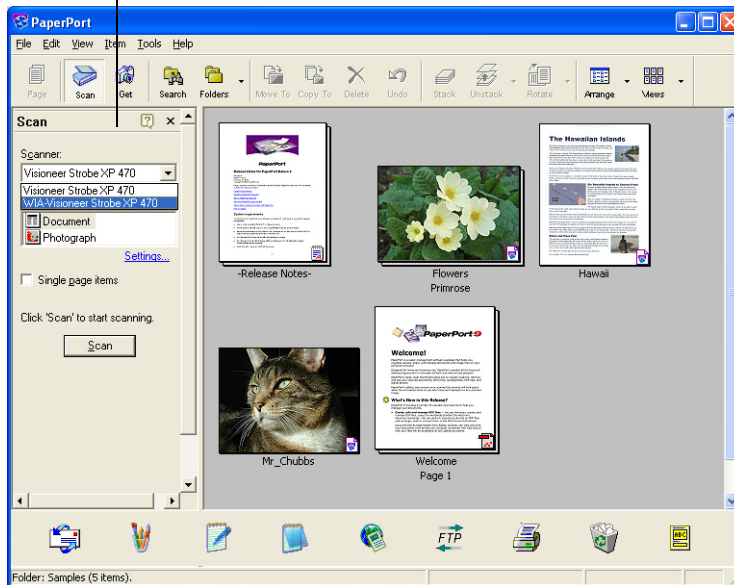

1. From the Scanner list, select **WIA-Visioneer Strobe XP 470**.

2. In the “Scan what?” section, choose to scan a **Document** or **Photograph**.
3. Click **Settings** to view and change the format for the scanned item's file name and the file type. The default file type for documents is .pdf and for photographs is .jpg.
4. Use the **Single page items** check box as follows:
 - When the check box is selected, all pages in the document feeder are scanned and placed as single pages on the PaperPort desktop.
 - When the check box is not selected, all pages in the document feeder are scanned, but not placed on the PaperPort desktop until you indicate the scanning job is finished.
5. Click the **Scan** button in the Scan pane.

The scan window opens. Use this window to select scanning options and start the scanner.

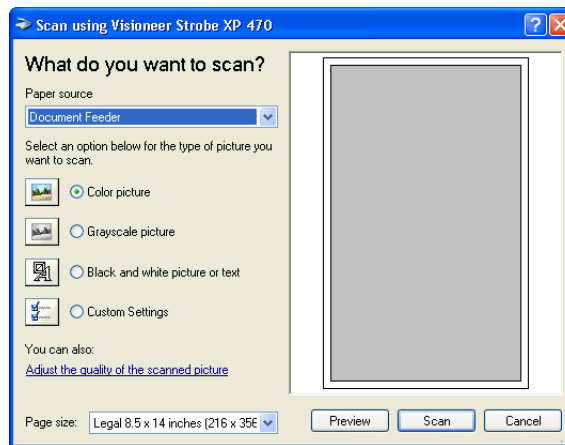

6. Click the button most appropriate for the item you're scanning.
7. Select a paper size from the Page Size list.
8. Click **Preview** to preview the image before scanning.
The image is displayed on the right side of the window.

Note: If you preview when scanning a stack of documents, the first page of the stack feeds through the ADF for the preview. After adjusting the scanner settings, replace that page on the stack so it is scanned with the rest of the pages.

9. Adjust settings of the previewed image as desired:
 - Change the button selection for the type of image.
 - Adjust the custom settings; refer to the next section, “Fine Tuning Your Scans”.
 - Change the size of the scanned image. To do this, click and hold the mouse pointer over one of the four sizing-boxes on the corners of the previewed image. Then drag the box to increase or decrease the size of the image.
10. Preview the image again. When you are satisfied with the image, click the **Scan** button.

If the **Single page items** check box is selected on the Scan pane, the scanned item appears as a thumbnail on the PaperPort desktop.
11. If the **Single page items** check box is not selected, thumbnails do not appear until you indicate the scanning job is finished.
12. On the PaperPort - Scan message box, click **Done**.

Note: Refer to “The Single Page Items Check Box” on page 104.

FINE TUNING YOUR SCANS

You can select new settings before you scan an item to fine tune exactly how you want to scan a particular item.

To select the scanner settings before you scan:

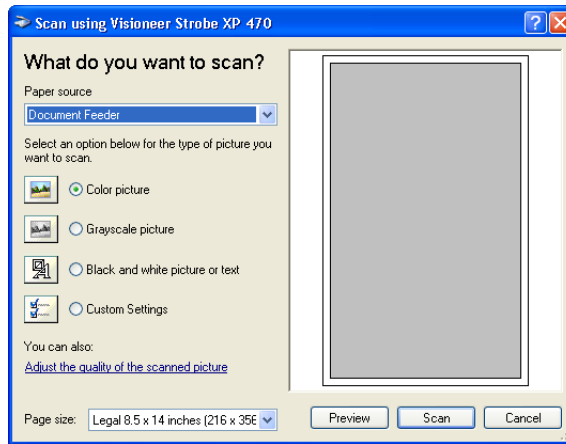

1. On the scan window, click **Adjust the quality of the scanned picture**.

The Advanced Properties dialog box opens.

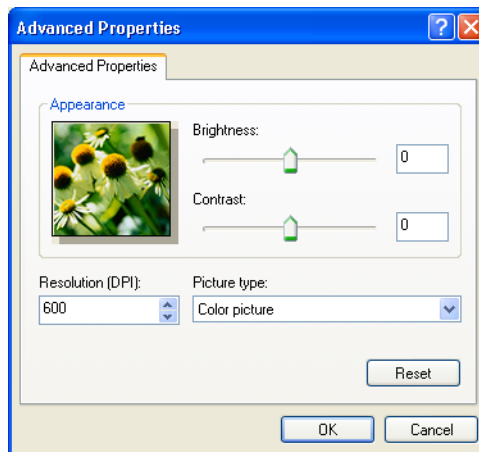

2. Select the options for scanning.

Brightness and **Contrast**—Drag the sliders to the right or left to adjust the brightness and contrast of the scanned image. The Contrast setting does not apply to the setting **Black and White picture or text**.

Resolution (DPI)—Click the menu arrow and choose the dots per inch (dpi) of the resolution. The maximum resolution is 600 dpi; the minimum is 50 dpi. The higher the dpi setting, the sharper and clearer the scanned image. However, higher dpi settings take longer to scan and produce larger files for the scanned images.

Picture type—Click the menu arrow and choose the most appropriate type for the item you're scanning.

3. Click **OK**.

The Custom Settings button is now set to scan with the options you selected.

If you want to reset the settings and start over, click **Reset**.

Maintenance

This chapter contains information on recalibrating, troubleshooting, cleaning, uninstalling, and scanner specifications.

This section contains information on maintenance, troubleshooting, uninstalling, scanner specifications, and spare parts.

CLEANING THE AUTOMATIC DOCUMENT FEEDER

You may need to clean the ADF feed mechanism if your documents do not feed easily into the ADF, or several feed in at the same time.

To clean the ADF:

1. Wet a cotton swab with some isopropyl alcohol (rubbing alcohol).
2. Press the ADF cover release on the top left of the scanner body to open the automatic document feeder cover.

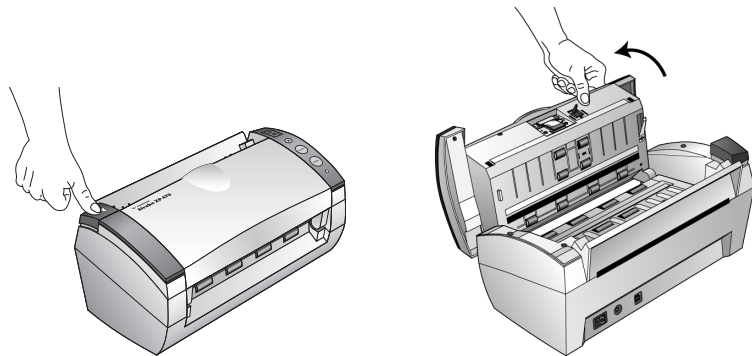

3. Wipe the feed roller from side to side. Rotate the roller to clean its entire surface.
4. Wipe the pad from top to bottom. Be careful not to snag the swab on the springs on either side of the pad.
5. Close the cover when you're finished.

CLEARING PAPER JAMS

If your scanner stops scanning due to a paper jam in the Automatic Document Feeder, a warning dialog box opens after a few moments.

To clear a paper jam:

1. Press the ADF cover release on the top-left of the scanner body to open the automatic document feeder cover.

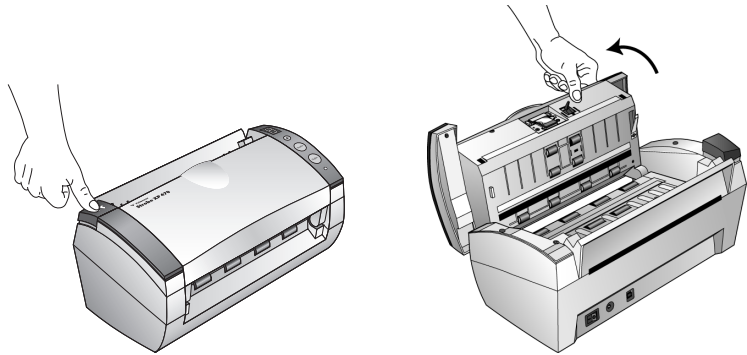

2. Remove the jammed paper and close the cover.

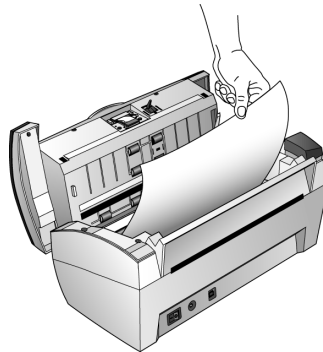

To reduce the number of paper jams, smooth and straighten the paper before scanning and adjust the guides to the paper size.

REPLACING THE ADF PAD ASSEMBLY

The ADF pad spring may wear out and is designed to be a user-replaceable part. Problems with documents feeding into the ADF is an indication that the pad spring may be wearing out.

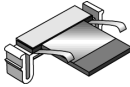

See the “Visioneer Strobe XP 470 Scanner Parts List” on page 135 for ordering information.

To replace the ADF Pad assembly:

1. Press the ADF cover release on the top left of the scanner body to open the automatic document feeder cover.

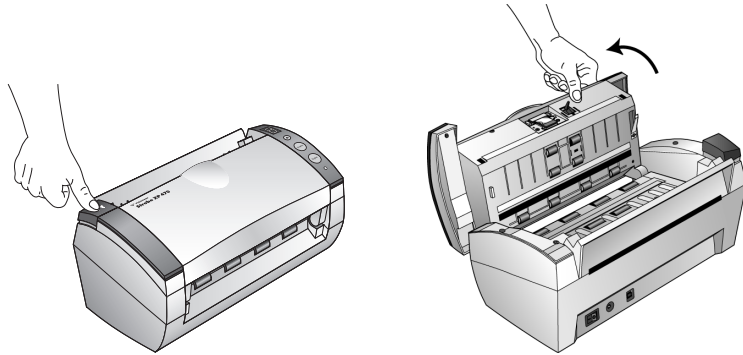

2. Squeeze the plastic clamps that hold the pad assembly in place and lift the pad up and out

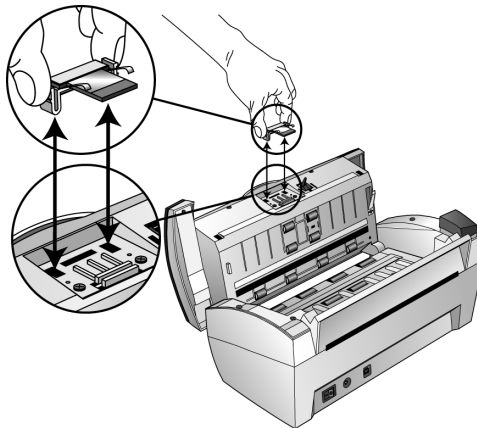

3. Reverse the procedure to replace the new pad into its slots.

TROUBLESHOOTING

In addition to the troubleshooting information contained in this section, please see the Readme file on your installation CD. The Readme file contains additional information that may help you diagnose problems with the scanner.

If you try the troubleshooting procedures described in this section and in the Readme file, and the scanner still has problems, you may have a malfunctioning scanner. Refer to the technical support card that you received with your scanner. Also visit our web site at www.visioneer.com for additional technical information.

Problem: The scanner won't scan. What's wrong?

Check for one of these possible problems:

- **Are the cables loose or not plugged in securely?** Inspect the cable connections. Make sure the cables are plugged in securely.
- **Is the scanner's status light on?** Turn on the scanner's power. If the status light doesn't come on, plug the power supply into another electrical outlet.
- **Did you restart the computer after installing the software?** If you didn't restart the computer, it may not have loaded all of the software files. Try restarting your computer.
- **Did you plug the scanner into a USB hub?** If you're using a USB hub to connect the scanner, the hub must have its own power supply. If the hub does not have its own power supply, plug the scanner into a USB port on the computer.
- **Did you select another scanning source in the PaperPort Scan Pane?** If you use multiple devices with your computer, you may have selected another source for images. Start the PaperPort software and click the **Scan** icon, and then make sure **Visioneer Strobe XP 470** is selected as the scanner.

Problem: During installation I got the error message: PaperPort Installation is not complete. What do I do?

The installation procedure was not successful. You need to reinstall the PaperPort software.

Problem: With AutoCrop to Original selected, sometimes I get blank pages, or pages with lines. What's wrong?

The pages were probably scanned in crookedly, or skewed. To use AutoCrop to Original, the pages must be scanned in straight. Adjust the paper guides on the scanner so pages feed in straight.

Problem: I got the error message: PaperPort cannot allocate enough memory to perform internal critical operations. What do I do?

Close any other active applications so that additional memory is available. If you click Continue, PaperPort moves the file to the PaperPort data directory and renames the file with the prefix "bad". This allows you to recover the file later.

To recover the file, you can import it into PaperPort by using the Import command in the File menu.

Problem: How do I uninstall PaperPort?

See the section "Uninstalling Your Scanner" on page 131. Uninstalling does not delete your scanned items, and they remain in the PaperPort Data folder.

STATUS LIGHT TROUBLESHOOTING CODES

A green status light indicates the normal state of the scanner.

NORMAL OPERATION

- **Blinking green:** indicates the scanner is waking up from power saving and preparing to scan.
- **Steady green:** indicates the scanner is ready to scan.

ERROR CODES

If your scanner experiences hardware problems, the status light will blink red, and the LED flashes an “E” and the error code number.

The LED blinks back and forth between “E” and the error code number (such as 6).

The red light flashes the number of times as the error code (6 in this example).

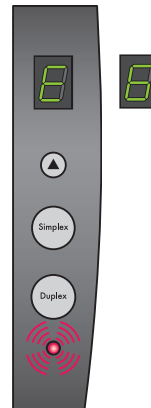

The table below describes the error codes.

Error Code	Problem Description	Solution
0	Scanner is not connected to the computer. (The LED does not flash "E" and the status light remains green.)	A cable may be loose. Check that the scanner's cables are correctly attached to the computer. If the scanner still does not connect, re-boot the computer.
1	The scanning hardware in the body of the scanner has malfunctioned.	Re-boot your computer. If the problem persists, contact Visioneer Technical Support.
2	The scanning hardware in the ADF portion of the scanner has malfunctioned.	Re-boot your computer. If the problem persists, contact Visioneer Technical Support.
3	The main board in the scanner has malfunctioned.	Re-boot your computer. If the problem persists, contact Visioneer Technical Support.
4	The CCD in the body of the scanner has malfunctioned.	Re-boot your computer. If the problem persists, contact Visioneer Technical Support.
5	The CCD in the ADF portion of the scanner has malfunctioned.	Re-boot your computer. If the problem persists, contact Visioneer Technical Support.
6	The scanner's cover is open.	Close the scanner cover and make sure it attaches completely.
7	The lamp in the scanner body has malfunctioned.	Make sure that the lamp has not been turned off manually. See the steps on page 92 to turn the lamp on and off. Re-boot your computer. If the problem persists, contact Visioneer Technical Support.
8	The lamp in the ADF portion of the scanner has malfunctioned.	Make sure that the lamp has not been turned off manually. See the steps on page 92 to turn the lamp on and off. Re-boot your computer. If the problem persists, contact Visioneer Technical Support.
9	Paper jam	See "Clearing Paper Jams" on page 125.

UNINSTALLING YOUR SCANNER

To uninstall the Visioneer Strobe XP 470 scanner, remove the OneTouch software first, and then remove PaperPort, or other scanner software.

STEP 1: UNINSTALLING THE SCANNER AND ONETOUCH SOFTWARE

1. On the Windows taskbar, click **Start**, point to **Settings**, and then click **Control Panel**.
2. Double-click the **Scanner/Cameras** icon.
 - For Windows 2000, click the **Devices** tab, select the **Visioneer Strobe XP 470** scanner, and click the Remove button to remove the scanner from the list. Click **OK**.
 - For Windows Me or XP, right-click the **Visioneer Strobe XP 470** icon, and select **Delete** to delete the scanner from the list.
3. Unplug the USB cable from the scanner.
4. Click the **Back** button in the toolbar to go back to the Control Panel.
5. Double-click the **Add/Remove Programs** icon.
 - Windows Me: The Add/Remove Programs Properties window opens. Select the Install/Uninstall tab.
 - Windows 2000 or XP: The Add or Remove Programs window opens. Make sure the Change or Remove option is selected.
6. From the list of programs, select **OneTouch 4.0**.
 - Windows Me: Click the **Add/Remove** button.
 - Windows 2000 or XP: Click the **Change/Remove** button.
7. On the OneTouch 4.0 InstallShield Wizard window, select **Remove** and then click **Next**.
8. On the Confirm Uninstall window, click **OK**.

9. On the Maintenance Complete window, click **Finish**.
The OneTouch software is removed from your computer.
10. Close all open windows and restart your computer.

STEP 2: UNINSTALLING THE PAPERPORT SOFTWARE

To uninstall PaperPort 9.0 from Windows Me:

1. On the Windows taskbar, click **Start**, point to **Settings**, and then click **Control Panel**.
2. Double-click the **Add/Remove Programs** icon.
3. On the Add/Remove Programs Properties window, select the **Install/Uninstall** tab.
4. Select **PaperPort 9.0** and click **Remove**.
5. On the Welcome window, click **Next**.
6. On the Program Maintenance window, select the **Remove** option, and then click **Next**.
7. On the Remove the Program window, select the **Remove files** option, and then click **Remove**.
The PaperPort software is removed.
8. On the Uninstall Completed window, click **Finish**.
9. Close all open windows and restart your computer.

To uninstall PaperPort 9.0 from Windows 2000 or XP:

1. On the Windows taskbar, click **Start**, point to **Settings**, and then click **Control Panel**.
2. Click the **Add or Remove Programs** icon.
The Add or Remove Programs window opens.
3. Select **PaperPort 9.0** and click **Remove**.

4. A message window opens, asking if you are sure you want to remove PaperPort 9.0 from your computer. Click **Yes**.

The PaperPort software is removed.



5. Close all open windows and restart your computer.

VISIONEER STROBE XP 470 SCANNER SPECIFICATIONS

Optical resolution	600 x 1200 dpi
Bit depth	48-bit color (internal)
Maximum item size	8.5" x 14"
Minimum item size	3.5" x 2" (automatic document feeder)
Scan method	Automatic document feeder (ADF)
ADF specifications	
Scanning Speed	Up to 33 pages per minute. Up to 66 images per minute @ 200 dpi B&W
Capacity	50 sheets
Paper Thickness	16 - 28 lbs. (0.002" - 0.006")
Light source	Cold cathode fluorescent lamp
Interface	USB 2.0 High Speed
Scanner dimensions	
Height	12.5 inches (31.75 cm)
Width	13.25 inches (33.66 cm)
Length	17 inches (43.18 cm)
Weight	8.6 pounds (3.91 kg)
Operating temperature	50°–104° F (5°–35° C without condensation)
Relative humidity	40%–70% (@35° C without condensation)
Power adaptor	DC Jack, 24V/2.0A (60W), 100-240V (with EMI core)
Power consumption	< = 30 Watts
Safety and agency certifications	UL, C-UL, FCC Class B, CE

VISIONEER STROBE XP 470 SCANNER PARTS LIST

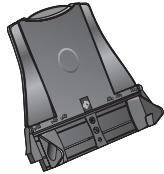
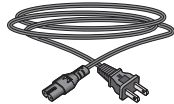
Please use the following part names and numbers when ordering replacements for your scanner.

	Part Name	Part Number
	Paper Guide	57-0104-000
	Output Tray	57-0105-000
	ADF Pad	57-0103-000
	AC Power Cord	35-0071-000
	Power Supply	37-0067-000
	Buttons Label	09-0631-000

INDEX**A**

ADF cleaning 124
 ADF pad assembly replace 126
 Advanced Interface 96, 105
 adjust settings 108
 new profile 117
 profile 117
 Advanced Properties 122
 advanced settings 63
 AOL Version 9 47
 Archive button 89
 aspect ratio 65
 Autocrop to Original 61
 AutoRotate image 65

B

background color 76
 Basic Interface 101
 bit depth 134
 Black&White 59, 106
 blurred image 111
 BMP 49
 Brightness 60, 112, 123
 Burn to CD 45, 82
 Destination Application 83
 button options 55
 button settings 38

C

CD-ROM drive 4
 Color 60, 106
 color
 hue 113
 options 113
 Color Document 39
 color filter 63
 color space 13
 Comma Delimited 53
 components 2
 computer specifications 4
 Configure Before Scan 68

Contrast 60, 112, 123
 csv file format 53

D

date format 99
 Destination Application 25, 35
 OCR 71
 text file format 51
 Destination Selector 27
 Device Settings 59, 64
 Disc 1 8
 Document Format 35
 Document Management 56
 documentation 4
 dots-per-inch 110
 dpi 110, 123
 Duplex 62
 duplex button 3, 25, 27, 62

E

eMail 56
 eMail Properties 47
 error codes 129
 Excel Spreadsheet 53

F

Fax and Print 56
 file format 52
 file storage location 90
 file type 99
 flowing page 78
 folder pane 96
 Font Matching 74
 Format and Page(s) 39
 full feature install 12

G

gamma 13, 63, 113
 grayed out options 36
 GrayScale 60, 106

H

help 104
 htm file format 53

HTML Document 53
 HTML page 88
 HTML Web Page 86
 hue 63

I

image
 blur 111
 preview 106
 Image Documents Properties 44
 Image Editors 56
 image file 49
 image file format 49
 image size 114
 improvements and settings 61
 input size 114
 installation 5
 invert image 62
 inverted text 76
 ISIS 69

J

JPG 49
 JPG file size 50

L

lamp malfunction 130
 Lamp timeout setting 94
 Languages in Document 73
 LED number 25, 62
 Link Properties 40

M

Microsoft Internet Explorer 87
 Microsoft Outlook 47
 Moire Patterns 62, 111
 monitor 4

N

Normal PDF 53, 79
 nPDF 39, 50, 53, 59, 79

O

OCR 51

columns 77
 optical character recognition 70
 storage 90
 tables 77

OCR button 70
 OCR Dictionary 73
 OCR Options 71, 72
 OmniPage Pro 12 44, 53
 on/off switch 17
 One Touch Button Panel 28, 30, 89
 Button View 31
 Detail View 32
 Hardware View 33
 initial settings 34
 names 33, 54
 OCR 71
 One Touch icon 30, 31, 35
 One Touch Properties window 28, 35, 40
 options 55, 58

P

Page Format
 HTML 86
 page format options 49
 page settings 61
 page size 61
 paper guide 6
 paper jam 125, 130
 PaperPort 95
 desktop 96
 help topics 104
 Scan pane 97
 thumbnail 103
 PaperPort Properties 41
 pause scanning 27
 PDF 50, 56
 PDF file size 50
 Picture type 123
 power saving 93
 Preview button 101, 120
 preview image 106

R
 Reject Character 74

Resolution 60, 110, 123

Rich Text Format 52

rtf file format 52

ruler units 116

S

saturation 63, 113

scan

file name 103

from PaperPort 95

multiple pages 103

PaperPort desktop 103

Scan Configuration 35

scan file name 99

Scan Info box 116

scan with event forwarding 84

scanner

components 2

connecting 16

troubleshooting 127

uninstall 131

Searchable PDF 53, 79

Select Configuration 37, 39

Select Destination 37, 39, 56

Select Format and Page(s) 38

Settings on the Scan Pane 98

setup 5

Show All Destinations 55

Show Hardware 92

Simple Text 52

simplex button 3, 25, 27, 62

single page items check box 97, 104, 121

size 61

skewed page 61

skip blank originals 62

sPDF 39, 50, 53, 59, 79

spreadsheet 77

spreadsheets

OCR 71

status light 17, 19, 127

troubleshooting codes 129

Sti event forwarding 56

Storage and CD-R/W 56

Storage Properties 45

Straighten Image 61

system requirements 4

T

template 77

text color 76

Text Documents Properties 42

Text Editors 56

text file format 51

Text Formats 51

thumbnail icon 99, 103

thumbnail image 27

TIFF 49

Transfer to Storage 89

troubleshooting 127

true page 78

TWAIN 69, 85

U

uninstall 131

USB port 17

V

VirtualReScan 69

W

watermark, remove 63

WIA 69, 119

Windows Image Acquisition 119

Word Document 52

X

xls file format 53

visioneer



Free Manuals Download Website

<http://myh66.com>

<http://usermanuals.us>

<http://www.somanuals.com>

<http://www.4manuals.cc>

<http://www.manual-lib.com>

<http://www.404manual.com>

<http://www.luxmanual.com>

<http://aubethermostatmanual.com>

Golf course search by state

<http://golfingnear.com>

Email search by domain

<http://emailbydomain.com>

Auto manuals search

<http://auto.somanuals.com>

TV manuals search

<http://tv.somanuals.com>