

Quick Start **CLUB-8000**



Quick Reference Setup Guide

This quick reference guide is provided to help you set up your **CLUB-8000** system for the first time. It contains instructions on setting up the products that are included in the **CLUB-8000**. If you are connecting any additional gear that is not included in the **CLUB-8000**, refer to the appropriate manuals for detailed instructions.

Gathering Package Contents

The first step to putting together your new **CLUB-8000** system is unpacking all of the necessary equipment. Remember to keep your manuals nearby when setting up, as you may need to reference them. The products listed below are included in the **CLUB-8000** system:

CDG-9000 PRO

- 1 Control interface connector wire
- [1] Instruction Manual

KJM-8000+ 9-Channel Digital Key Control KJ/DJ Mixer

- [1] Instruction Manual

VP-2100 PRO 2000W Professional Power Amplifier

- [1] Instruction Manual

VX-15 Vocal Speakers

- [4] VX-15 speakers

VSP-M1 Multi-Effect Digital Signal Processor/Mixer

- 1 Instruction manual

SS-88 Speaker Stands

- [4] SS-88 speaker stands

CLUB-8 Road Case

- [1] CLUB-8 road case
- [1] Rolling cart
- [2] MK-38 PRO microphones
- [1] Gooseneck DJ light
- 1 RCA to 1/4" Patch Cable (3.3 ft paired)
- Rack-mounting screws

Mounting components into the CLUB-8

Follow these basic guidelines when mounting:

- Always screw in the mounting screws using an "X" formation.
- If possible, to keep the products cooler, leave some space in between the components in the rack.

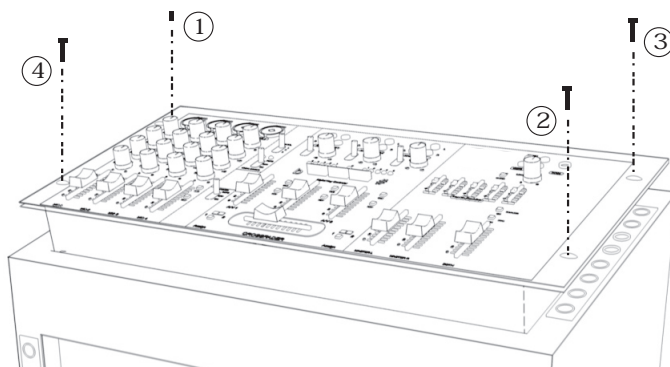

Below is one way to configure your CLUB-8000:

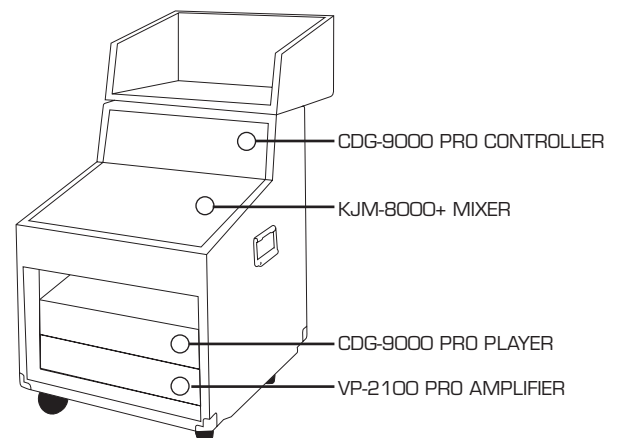

Vocopro
THE SINGERS ULTIMATE CHOICE

On the web at www.vocopro.com
or call toll free **1-800-678-5348**

Setting up the speakers and speaker stands

1. Setup each SS-88 speaker stand by extending the support legs to a position that is stable and tighten the tension mechanism firmly.
2. Place a VX-15 speaker on top of the SS-88 so that the shaft of the SS-88 fits flush into the mounting cavity on the bottom of the VX-15.

NOTE: Each end of the SS-88 pole has a particular diameter fitted for common speakers' mounting cavities. If the SS-88 shaft does NOT fit flush into the mounting cavity on the VX-15, loosen the SS-88 pole and reverse it in the stand and then remount the speaker.

3. Repeat the above steps for each speaker and stand.

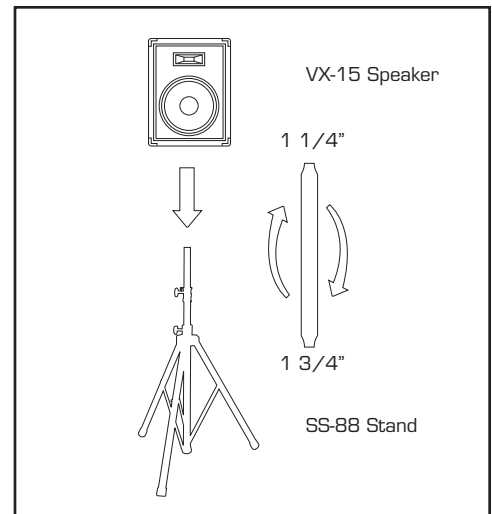

Connecting Power

Be sure that each product has a power cord firmly attached. It is recommended that you use a power strip/surge protector when connecting your CLUB-8000 to a power outlet.

Connecting the components

Once you have mounted all of the components into the CLUB-8, it is time to connect them. Follow these directions on connecting the components.

NOTE: If you are also connecting components that are not part of the CLUB-8000 system, please refer to the manual of that product for setup instructions.



**MAKE SURE ALL PRODUCTS ARE POWERED OFF
PRIOR TO CONNECTING TO AN AC OUTLET**



1

CDG-9000 PRO remote unit to the player unit

Connect the Control Interface Connector from "CONNECT TO MAIN UNIT" jack on the rear panel of the remote unit to the "CONNECT TO REMOTE CONTROLLER" jack on the rear panel of the player unit.

CDG-9000 PRO Controller



CDG-9000 PRO Player

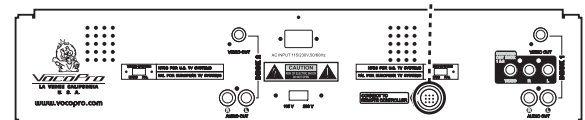

2

CDG-9000 PRO player unit to KJM-8000+

You have the option of either connecting each deck of the CDG-9000 PRO separately (Fig. 1) or together through a single SWITCHED output (Fig. 2).

Separately through individual deck outputs (Fig. 1)

Using RCA cables:

1. For each deck, connect the L/R (red & white) audio outputs and Video (yellow) output on the CDG-9000 PRO to the CDG(1) and DVD(3) inputs on the rear panel of the KJM-8000+

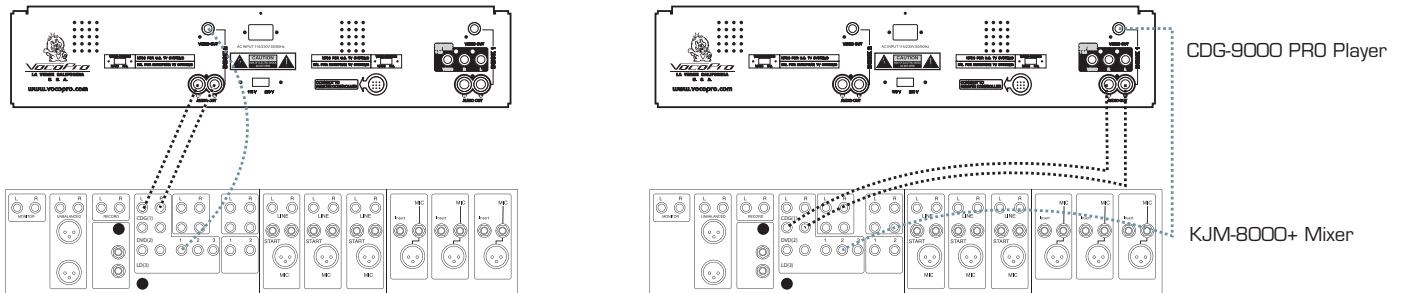

Together through SWITCHED output (Fig. 2)

Using RCA cables:

1. Connect the L/R SWITCHED audio and SWITCHED video outputs on the CDG-9000 PRO player to the CDG(1) audio input on the KJM-8000 PRO

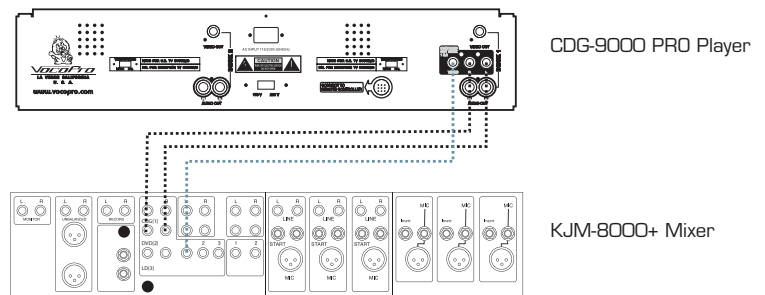

3

KJM-8000+ to VP-2100 PRO

You can do this using either XLR(f) to XLR(m) cables or XLR(f) to 1/4"(m) cables. Below are instructions for each.

Using two XLR(f) to XLR(m) (Fig. 1)

1. Connect the XLR(f) end to the LEFT MASTER AUDIO XLR output on the KJM-8000+ and the XLR (m) end to the left XLR audio input on the VP-2100 PRO.
2. Now do the same thing except now go from the RIGHT MASTER AUDIO XLR output on the KJM-8000+ and the right XLR audio input on the VP-2100 PRO

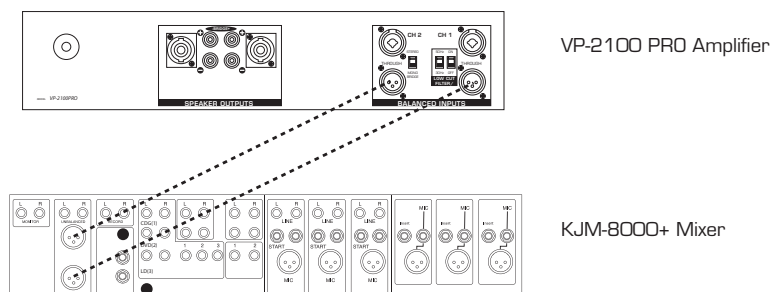

Using two XLR(f) to 1/4"(m) (Fig. 2)

1. Connect the XLR(f) end to the LEFT MASTER AUDIO XLR output on the KJM-8000+ and the 1/4"(m) end to the CH. B 1/4" audio input on the VP-2100 PRO.
2. Now do the same thing except now go from the RIGHT MASTER AUDIO XLR output on the KJM-8000+ and the CH. A 1/4" audio input on the VP-2100 PRO.

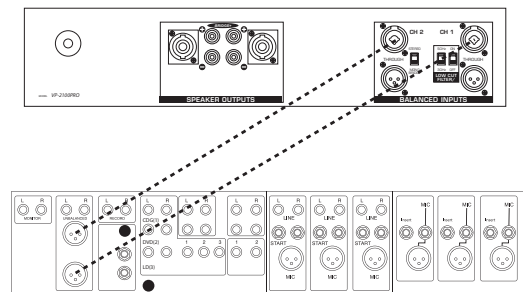

4 VP-2100 PRO to VX-15 speakers

Speakers 1 and 2

Using the SPEAKON style to 1/4" adapter and 1/4"(m) to 1/4"(m) cable (included):

1. Connect the SPEAKON style end to CH.1 on the rear panel of the VP-2100 PRO
2. Connect one end of the 1/4" cable to the 1/4" end of the adapter
3. Connect the other end of the 1/4" cable to one of the four VX-15's.
3. Repeat this for the second speaker, except now connect the SPEAKON style end to CH. 2 on the VP-2100 PRO and the 1/4" end to the second VX-15 speaker.

VP-2100 PRO Amplifier

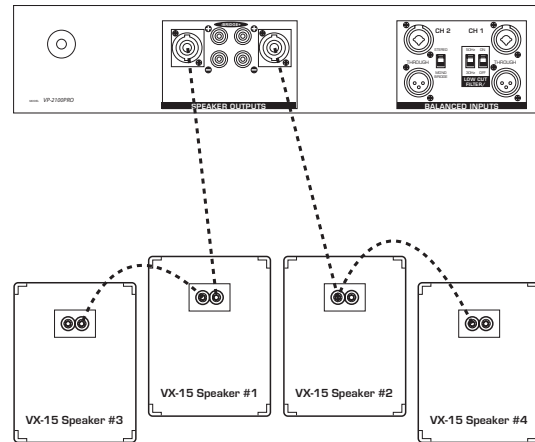

Speakers 3 and 4

Using a 1/4"(m) to 1/4"(m) cable

1. Connect one end of the 1/4" cable to the open 1/4" jack on the rear of speaker 1
2. Connect the other 1/4" end to the back of the 3rd speaker.
3. Repeat this for the final speaker now going from the back of speaker 2 and into the 4th speaker.

5 Connecting Microphones to the KJM-8000+

Using either a mic cable with two XLR ends (Fig. A) or an XLR to 1/4" cable (Fig. B):

Connect the microphone cables to the MIC inputs on the rear panel of the KJM-8000+.

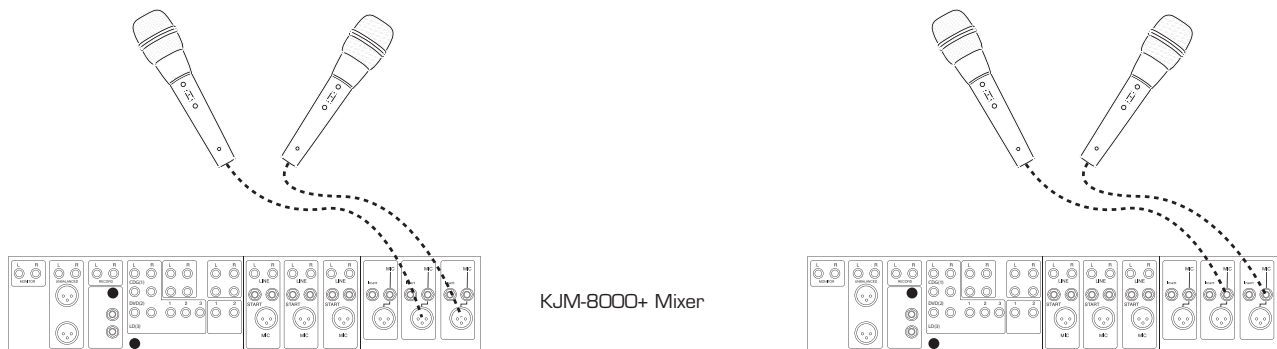

6 Adding the VSP-M1 to the CLUB-8000 system

Using either a mic cable with two XLR ends or an XLR to 1/4" cable:

1. Connect the XLR(f) end to the LEFT BALANCED OUTPUT on the rear panel of the VSP-M1.
2. Connect the XLR(m) or 1/4" end to MIC input 1 on the rear panel of the KJM-8000+.
3. Follow the above steps, now going from the RIGHT BALANCED OUTPUT on the VSP-M1 to MIC input 2 on the rear panel of the KJM-8000+.
4. Connect the mics to the mic inputs on the rear panel of the VSP-M1.

VSP-M1 Processor



KJM-8000 PRO Mixer

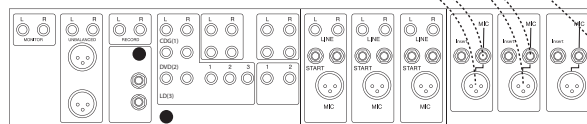

Free Manuals Download Website

<http://myh66.com>

<http://usermanuals.us>

<http://www.somanuals.com>

<http://www.4manuals.cc>

<http://www.manual-lib.com>

<http://www.404manual.com>

<http://www.luxmanual.com>

<http://aubethermostatmanual.com>

Golf course search by state

<http://golfingnear.com>

Email search by domain

<http://emailbydomain.com>

Auto manuals search

<http://auto.somanuals.com>

TV manuals search

<http://tv.somanuals.com>