



VOLVO C70  
**OWNER'S MANUAL**



WEB EDITION

## **DEAR VOLVO OWNER**

THANK YOU FOR CHOOSING VOLVO

We hope that you will enjoy many years of driving pleasure in your Volvo. The car has been designed for the safety and comfort of you and your passengers. Volvo is one of the safest cars in the world. Your Volvo has also been designed to satisfy all current safety and environmental requirements.

In order to increase your enjoyment of the car, we recommend that you familiarise yourself with the equipment, instructions and maintenance information contained in this owner's manual.





## 00 Introduction

Introduction .....	6
Volvo Car Corporation and the environment .....	7



## 01 Safety

Seatbelts .....	12
Airbag system .....	15
Airbags (SRS) .....	16
Activating/deactivating the airbag (SRS) .....	18
Side airbags (SIPS bags) .....	20
Inflatable Curtain (IC) .....	22
WHIPS .....	23
Roll-Over Protection System (ROPS) .....	25
When the systems deploy .....	26
Crash mode .....	27
Child safety .....	28



## 02 Instruments and controls

Overview, left-hand drive car .....	34
Overview, right-hand drive car .....	36
Driver's door control panel .....	38
Combined instrument panel .....	39
Indicator and warning symbols .....	40
Information display .....	44
Electrical socket .....	45
Lighting panel .....	46
Left-hand stalk switch .....	48
Right-hand stalk switch .....	50
Cruise control (option) .....	52
Steering wheel keypad (option) .....	53
Steering wheel adjustment, hazard warning flashers .....	54
Parking brake .....	55
Power windows .....	56
Rearview and door mirrors .....	57
Personal preferences .....	61



### 03 Climate control

General information on climate control .....	66
Electronic climate control, ECC .....	68
Air distribution .....	71
Fuel-driven heater (option) .....	72



### 04 Interior

Front seats .....	76
Electrically operated roof .....	79
Wind deflector (option) .....	83
Interior lighting .....	84
Storage spaces in the passenger compartment .....	86
Cargo area .....	90



### 05 Locks and alarm

Remote control with key blade .....	96
Active locks .....	99
Privacy locking (option) .....	100
Keyless drive (option) .....	102
Battery in remote control .....	105
Locking and unlocking .....	106
Alarm (option) .....	110



## 06 Starting and driving

General .....	116
Refuelling .....	118
Starting the engine .....	119
Diesel particle filter (DPF) .....	120
Ignition switch and steering lock ....	121
Keyless drive .....	122
Manual gearbox .....	123
Automatic gearbox .....	125
Brake system .....	128
DSTC – Stability and traction control system .....	130
Parking assistance (option) .....	132
BLIS – Blind Spot Information System (option) .....	135
Towing and recovery .....	138
Jump starting .....	140
Driving with a trailer .....	141
Towing equipment .....	143
Detachable towbar .....	145
Loading .....	150
Adjusting headlamp pattern .....	151



## 07 Wheels and tyres

General .....	154
Tyre pressure .....	158
Warning triangle and spare wheel .....	160
Changing wheels .....	162
Emergency puncture repair .....	164



## 08 Car care

Cleaning .....	170
Touching up paintwork .....	173
Rustproofing .....	174

07

08



## 09 Maintenance and service

Volvo service .....	178
Self-maintenance .....	179
Bonnet and engine compartment ..	180
Diesel .....	181
Oils and fluids .....	182
Wiper blades .....	187
Battery .....	188
Replacing bulbs .....	190
Fuses .....	196



## 10 Infotainment system

General .....	206
Audio functions .....	207
Radio functions .....	211
CD functions .....	215
Menu structure – audio system .....	217
Phone functions (option) .....	218
Menu structure – phone .....	225



## 11 Specifications

Type designation .....	232
Dimensions and weights .....	233
Engine specifications .....	235
Engine oil .....	237
Fluids and lubricants .....	241
Fuel .....	242
Catalytic converter .....	244
Electrical system .....	245
Type approval .....	247



## Introduction

### Owner's Manual

A good way of getting to know your new car is to read the owner's manual, ideally before your first journey. This will give you the opportunity to familiarise yourself with new functions, to see how best to handle the car in different situations, and to make the best use of all the car's features. Please pay attention to the safety instructions contained in the manual:



#### WARNING

"Warning!" texts indicate where there is a risk of personal injury in the event of the instructions not being followed.



#### IMPORTANT

"Important!" texts indicate a risk of damage to the car in the event of the instructions not being followed.

The equipment described in the owner's manual is not present in all models. In addition to standard equipment, this manual also describes options (factory fitted equipment) and certain accessories (extra equipment).



#### NOTE

Volvo cars are adapted for the varying requirements of different markets, as well as for national or local legal requirements and regulations. If you are uncertain over what is standard, an option or an accessory then contact your Volvo dealer.

The specifications, design features and illustrations in this owner's manual are not binding. We reserve the right to make modifications without prior notice.

© Volvo Car Corporation



## Volvo Car Corporation and the environment

### Volvo Cars' environmental philosophy



Environmental care, safety and quality are the three core values which influence all operations of the Volvo Car Corporation. We also believe that our customers share our consideration for the environment.

Your Volvo complies with strict international environmental standards and is also manufactured in one of the cleanest and most resource-efficient plants in the world.

Volvo Car Corporation has global ISO certification, which includes the environmental standard (ISO 14001) covering factories, central functions, as well as several of our

other units. We also set requirements for our partners so that they work systematically with environmental issues.

EPI (Environmental Product Information) is supplied for all Volvo models. Here you can see how the environment is affected during the entire lifecycle of the car.

Read more at [www.volvocars.com/EPI](http://www.volvocars.com/EPI).

#### **Fuel consumption**

Volvo cars have competitive fuel consumption in each of their respective classes. Lower fuel consumption generally results in

lower emission of the greenhouse gas, carbon dioxide.

It is possible for the driver to influence fuel consumption. For more information read under the heading Reducing environmental impact on page 8.





## Volvo Car Corporation and the environment

### Efficient emission control

Your Volvo is manufactured following the concept **Clean inside and out** – a concept that encompasses a clean interior environment as well as highly efficient emission control. In many cases the exhaust emissions are well below the applicable standards.

### Clean air in the passenger compartment

A passenger compartment filter prevents dust and pollen from entering the passenger compartment via the air intake.

A sophisticated air quality system, IAQS<sup>1</sup> (Interior Air Quality System) ensures that the incoming air is cleaner than the air in the traffic outside.

The system consists of an electronic sensor and a carbon filter. The incoming air is monitored continuously and if there is an increase in the level of certain unhealthy gases such as carbon monoxide then the air intake is closed. Such a situation may arise in heavy traffic, queues and tunnels for example.

The entry of nitrous oxides, ground-level ozone and hydrocarbons is prevented by the carbon filter.

<sup>1</sup> Option

### Textile standard

The interior of a Volvo is designed to be pleasant and comfortable, even for people with contact allergies and for asthma sufferers. All of our upholstery and interior textiles are tested with respect to certain unhealthy substances and allergens as well as emissions. This means that all textiles fulfil the requirements in the Öko-Tex 100 standard<sup>2</sup>, a major advance towards a healthier passenger compartment environment.

Öko-Tex certification covers seatbelts, carpets and fabrics for example. The leather in the upholstery undergoes chromium-free tanning with natural plant substances and fulfils the certification requirements.

### Volvo workshops and the environment

Regular maintenance creates the conditions for a long service life and low fuel consumption for your car, and in this way you contribute to a cleaner environment. When Volvo's workshops are entrusted with the service and maintenance of your car it becomes part of our system. We make clear demands regarding the way in which our workshops are designed in order to prevent spills and discharges into the environment. Our workshop staff have the knowledge and the tools required to guarantee good environmental care.

<sup>2</sup> More information on [www.oekotex.com](http://www.oekotex.com)

### Reducing environmental impact

You can easily help reduce environmental impact, for example, by driving economically, by purchasing eco-labelled car care products and by servicing and maintaining the car in accordance with the instructions in the owner's manual.

The following hints will help you to do your bit for the environment (for further advice on how you can reduce environmental impact and drive economically, see page 116).

- Decrease fuel consumption by choosing ECO tyre pressure, see page 158.
- Remove unnecessary items from the car - the greater the load the higher the fuel consumption.
- Is your car equipped with an engine block heater? If so, use it for a few hours before starting from cold to reduce fuel consumption and exhaust emissions.
- Drive gently and avoid braking too hard.
- Drive in the highest gear possible. Low engine speeds result in lower fuel consumption.
- Use engine braking to slow down.
- Avoid idling. Take consideration of local regulations. Switch off the engine in longer stationary traffic.





## Volvo Car Corporation and the environment

- Always dispose of environmentally hazardous waste, such as batteries and oils, in an environmentally responsible manner. If uncertain, consult an authorised Volvo workshop for advice.

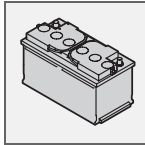

- Service your car regularly.
- High speed increases consumption considerably due to increased wind resistance. A doubling of speed increases wind resistance four times.

These hints will help you to reduce your fuel consumption without increasing your travel time or lessening the enjoyment of driving. Apart from being kind to your car, you'll be saving money - and the Earth's resources.

Seatbelts .....	12
Airbag system .....	15
Airbags (SRS) .....	16
Activating/deactivating the airbag (SRS) .....	18
Side airbags (SIPS bags) .....	20
Inflatable Curtain (IC) .....	22
WHIPS .....	23
Roll-Over Protection System (ROPS) .....	25
When the systems deploy .....	26
Crash mode .....	27
Child safety .....	28

## SAFETY



# 01



## Seatbelts

### Always use a seatbelt

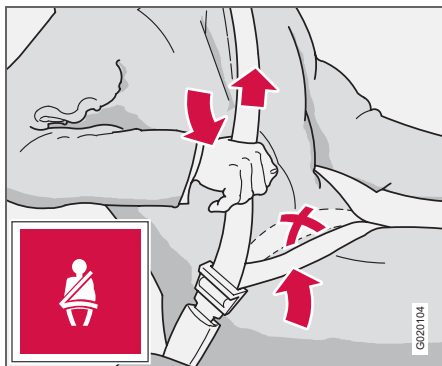

Tensioning the hip strap. The belt must be positioned low down.

Heavy braking can have serious consequences if the seatbelts are not used, so make sure that all passengers use their seatbelts. It is important that the seatbelt lies against the body so it can provide maximum protection. Do not lean the backrest too far back. The seatbelt is designed to protect in a normal seating position.

### Putting on a seatbelt:

- Pull the seatbelt out slowly and secure it by pressing the buckle into the lock. A loud "click" indicates that the seatbelt has locked.

### Releasing the belt

- Press the red lock button and then let the seatbelt retract. If the seatbelt does not retract fully, feed the seatbelt in by hand so that it does not hang loose.

The seatbelt locks and cannot be withdrawn:

- if it is pulled out too quickly.
- during braking and acceleration.
- if the car leans heavily.

### Keep in mind the following:

- do not use clips or anything else that can prevent the seatbelt from fitting properly
- ensure that the seatbelt is not twisted or caught on anything
- the hip strap must be positioned low down (not over the abdomen).

Tension the hip strap over the lap by pulling the diagonal shoulder belt as illustrated.

### WARNING

The seatbelts and airbags interact. If a seatbelt is not used or is used incorrectly, this may diminish the protection provided by the airbag in the event of a collision.

### WARNING

Each belt is intended for one person only.

### WARNING

Never modify or repair the seatbelt yourself. Contact an authorised Volvo workshop. If the seatbelt has been subjected to a major load, such as in a collision, the entire seatbelt must be replaced. Some of the seatbelt's protective properties may have been lost even if the seatbelt does not appear damaged. The seatbelt must also be replaced if it shows signs of wear or damage. The new seatbelt must be type-approved and designed for installation at the same location as the replaced seatbelt.

### WARNING

The rear seat is designed for a maximum of two passengers.



## Seatbelts and pregnancy



The seatbelt should always be worn during pregnancy. But it is crucial that it be worn in the correct way. The diagonal section of the seatbelt should wrap over the shoulder then be routed between the breasts and to the side of the abdomen. The lap section of the seatbelt should lay flat over the thighs and as low as possible under the abdomen. It must never be allowed to ride upward. Remove all slack from the seatbelt and ensure that it fits close to the body. In addition, check that there are no twists in the seatbelt.

As a pregnancy progresses, pregnant drivers should adjust their seats and steering wheel such that they can easily maintain control of

the vehicle as they drive (which means that they must be able to easily operate the foot pedals and steering wheel). They should strive to position the seat with as large a distance as possible between their abdomen and the steering wheel.

## Seatbelt reminder

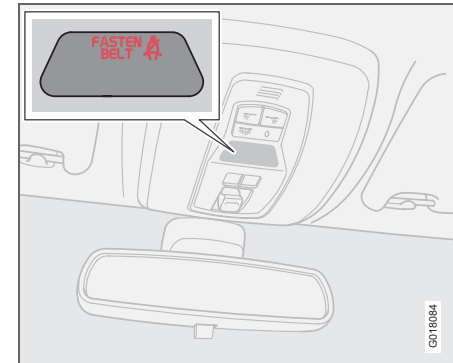

Unbelted occupants will be reminded to fasten their seatbelts through an audio and visual reminder. The audio reminder is speed dependent, and in some cases time dependent. The visual reminder is located in the roof console and the combined instrument panel.

Child seats are not covered by the seatbelt reminder system.

## Rear seat

The seatbelt reminder in the rear seat has two subfunctions:

- Provides information on which seatbelts are being used in the rear seat (shown on the information display). The message is



## Seatbelts

automatically cleared after approx. 30 seconds or can be acknowledged manually by pressing the **READ** button.

- To provide a warning if one of the rear seatbelts is unfastened during a journey. This warning takes the form of a message on the information display along with the audio/visual signal. The warning ceases when the seatbelt is re-fastened or when manually acknowledged by pressing the **READ** button.

The message on the information display showing which seatbelts are in use is always available. Press the **READ** button to see stored messages.

### Certain markets

An unbelted driver will be reminded to fasten his or her seatbelt through an audio and visual reminder. At low speed, the audio reminder will sound for the first 6 seconds.

### Seatbelt tensioner

All the seatbelts are equipped with seatbelt tensioners. A mechanism in the seatbelt tensioner tightens the belt around the body in the event of a sufficiently violent collision. The belt then provides more effective restraint for occupants.

### Seatbelt guide

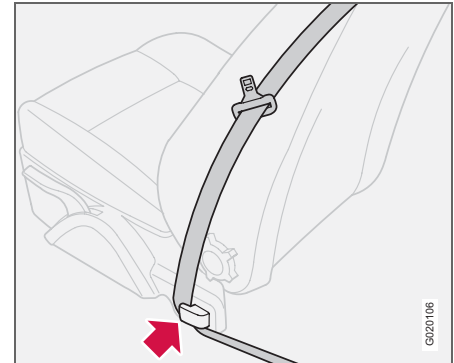

*The seatbelt guide is fitted on both the driver's seat and passenger seat.*

The seatbelt guide is an aid for providing better access to the seatbelt. When getting into and out of the rear seat remove the seatbelt from the seatbelt guide and position it furthest back on the seatbelt bar. Refit the seatbelt into the seatbelt guide afterwards.



### Warning symbol on the combined instrument panel

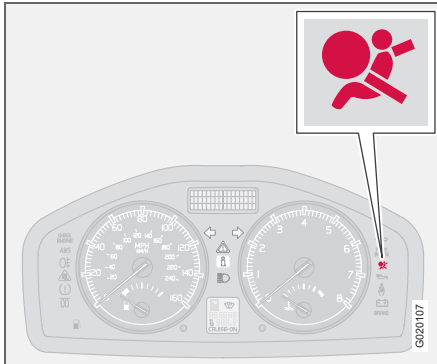

The airbag system<sup>1</sup> is continually monitored by the system control module. The warning symbol in the combined instrument panel illuminates when the ignition key is turned to position **I**, **II** or **III**. The symbol goes out after approx. 6 seconds provided the airbag system<sup>1</sup> is working correctly.



As well as the warning symbol, a message may appear on the information display in appropriate cases. Contact an authorised Volvo workshop urgently. If the warning symbol malfunctions, the warning triangle illuminates and the message **SRS AIRBAG SERVICE REQUIRED** or **SRS AIRBAG SERVICE URGENT** appears on the information display. Contact an authorised Volvo workshop urgently.



#### WARNING

If the warning symbol for the airbag system remains on or illuminates while driving, it means that the airbag system is not functioning fully. The symbol indicates a fault in the seatbelt buckle, SIPS, SRS system or IC system. Contact an authorised Volvo workshop urgently.

<sup>1</sup> Includes SRS and seatbelt tensioner, SIPS, DMIC and ROPS.





## Airbags (SRS)

### Airbag (SRS) on the driver's side

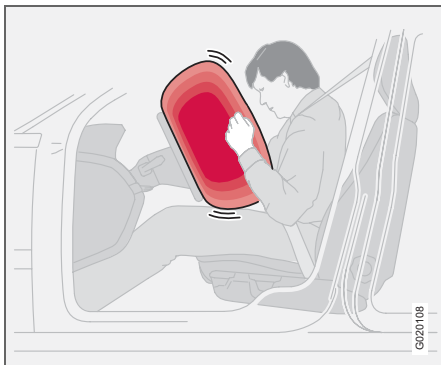

The car has an SRS airbag (Supplemental Restraint System) on the driver's side to supplement the protection afforded by the seatbelt. This airbag is folded up into the centre of the steering wheel. The steering wheel is marked **SRS AIRBAG**.

#### **WARNING**

The seatbelts and airbags interact. If a seatbelt is not used or is used incorrectly, this may diminish the protection provided by the airbag in the event of a collision.

### Passenger airbag (SRS)

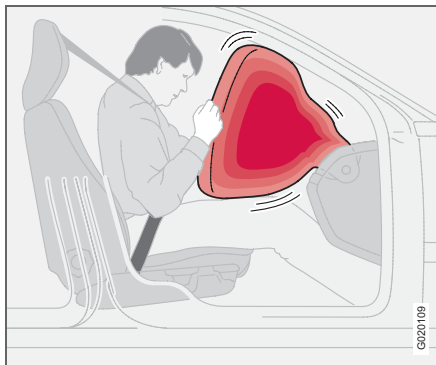

The car has an airbag<sup>1</sup> to supplement the protection afforded by the seatbelt on the passenger side. This airbag is folded up into a compartment above the glovebox on the passenger side. Its cover panel is marked **SRS AIRBAG**.

<sup>1</sup> Not all cars have a passenger airbag (SRS). This can be deselected when the car is ordered.

#### **WARNING**

To minimise the risk of injury if the airbag deploys, passengers must sit as upright as possible with their feet on the floor and backs against the backrest. Seatbelts must be secured.

#### **WARNING**

Never place a child in a child seat or on a booster cushion in the front seat if the airbag (SRS) is activated.<sup>1</sup>

Never allow a child to stand or sit in front of the front passenger seat. No one shorter than 140 cm should sit in the front passenger seat if the airbag (SRS) is activated.

Failure to follow the advice given above can endanger the life of the child.

<sup>1</sup> For information on activated/deactivated airbag (SRS) see page 18.



## Airbags (SRS)

01

## SRS system

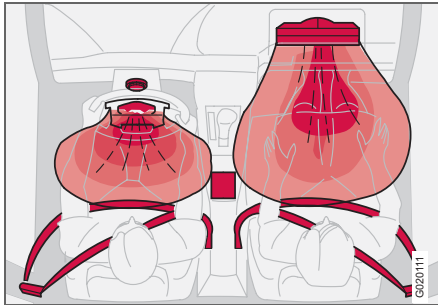

SRS system, left-hand drive

The system consists of airbags and sensors. A sufficiently violent collision trips the sensors and the airbag(s) are inflated with hot gas. To cushion the impact, the airbag deflates when compressed. When this occurs, smoke escapes into the car. This is completely normal. The entire process, including inflation and deflation of the airbag, takes place within tenths of a second.

**WARNING**

Repairs must only be performed by an authorised Volvo workshop. Any interference in the airbag system could cause malfunction and result in serious injury.

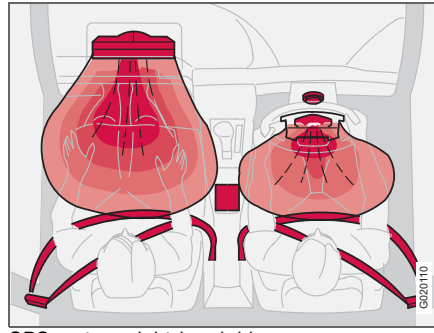

SRS system, right-hand drive

**NOTE**

The sensors react differently depending on the course of the collision and whether the seatbelts on the driver and passenger side are used. It is therefore possible that only one (or none) of the airbags may inflate in a collision. The SRS system senses the force of the collision on the car and adapts accordingly so that only the required airbag is deployed.

The airbags have a function whereby their capacities are adapted to the collision force to which the car is subjected.

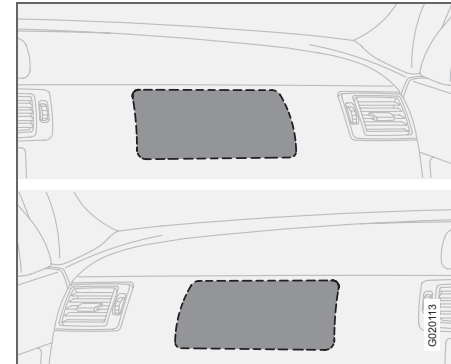

Location of the passenger airbag in left-hand drive and right-hand drive cars

**WARNING**

Do not put objects in front of or above the instrument panel where the passenger airbag is located.



## Activating/deactivating the airbag (SRS)

### PACOS<sup>1</sup> (option)

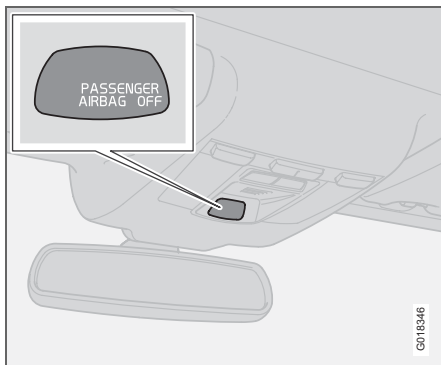

Indicator showing that the passenger airbag (SRS) is deactivated.

The airbag (SRS) for the front passenger seat can be deactivated if the car is equipped with a PACOS switch. For information on how to activate/deactivate, see page 19.

### Messages

A text message in the roof panel indicates that the airbag (SRS) for the front passenger seat is deactivated (see illustration above).

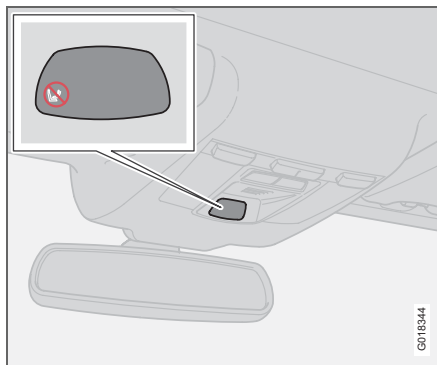

Indicator showing that the passenger airbag (SRS) is activated.

### NOTE

When the remote control key is inserted into ignition position II or III the warning symbol for the airbag is shown in the combined instrument panel for approx. 6 seconds (see page 15).

Following which, the indicator in the roof console is illuminated showing the correct status for the passenger seat airbag. For more information on the different ignition positions, see page 121.

A warning symbol in the roof panel indicates that the airbag (SRS) for the front passenger seat is activated (see illustration above).

For information on how switching takes place, see under the heading Activating/deactivating later in this chapter.

### Activating/deactivating

The switch for the passenger airbag (PACOS) is located on the passenger end of the instrument panel and is accessible when the passenger door is open, (see under the heading, Switch – PACOS below). Check that the switch is in the required position. Volvo recommends that the key blade is used to change position.

For information on the key blade, see page 98. (Other items with a shape similar to a key can also be used.)

### WARNING

Failure to follow the advice given above can endanger life.

### WARNING

If the car is equipped with a front passenger airbag (SRS), but does not have PACOS, the airbag will always be activated.

<sup>1</sup> PACOS (Passenger Airbag Cut Off Switch)



## Activating/deactivating the airbag (SRS)

### WARNING

Never place a child in a child seat or on a booster cushion in the front seat if the airbag is activated and the symbol in the roof console is illuminated. Failure to follow this advice could endanger the life of the child.

### WARNING

Do not allow anyone to sit in the front passenger seat if the text message in the roof panel indicates that the airbag (SRS) is deactivated and the Airbag system warning symbol is displayed in the combined instrument panel. This indicates that there has been a severe malfunction. Visit an authorised Volvo workshop urgently.

### Switch – PACOS

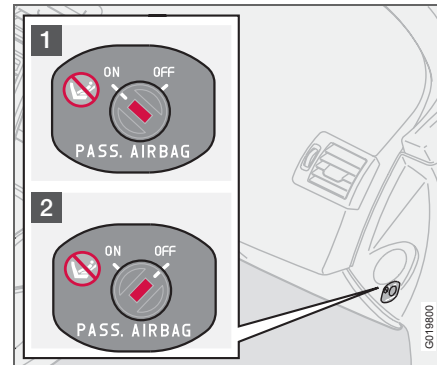

Switch location

1. The airbag is activated. With the switch in this position, persons taller than 140 cm can sit in the front passenger seat, but never children in a child seat or on a booster cushion.
2. The airbag is deactivated. With the switch in this position, children in a child seat or on a booster cushion can sit in the front passenger seat, but never anybody taller than 140 cm.

### WARNING

#### Activated airbag (passenger seat):

Never place a child in a child seat or on a booster cushion on the front passenger seat when the airbag is activated. This applies to everyone shorter than 140 cm.

#### Deactivated airbag (passenger seat):

No one taller than 140 cm should ever sit in the front passenger seat when the airbag is deactivated.

Failure to follow the advice given above can endanger life.



## Side airbags (SIPS bags)

### Side airbags – SIPS bags



Side airbag locations

A large proportion of the collision force is transferred by the SIPS (Side Impact Protection System) to beams, pillars, the floor, the roof and other structural parts of the body. The side airbags at the driver's and front passenger seats protect the chest area and are an important part of the SIPS. The side airbags are located in the front seat backrests.

#### **WARNING**

Repairs must only be performed by an authorised Volvo workshop. Any interference in the SIPS bag system could cause malfunction and result in serious personal injury.

#### **WARNING**

Do not put objects in the area between the outside of the seat and the door panel, since this area is required by the side airbag.

#### **WARNING**

Only use car seat covers approved by Volvo. Other seat covers may impede the operation of the side airbags.

#### **WARNING**

Side airbags are a supplement the seatbelts. Always wear your seatbelt.

### Child seats and side airbags

The side airbag does not diminish the protection provided by the car to children seated in a child seat or on a booster cushion.

A child seat or booster cushion can be placed on the front passenger seat provided that the car does not have an activated<sup>1</sup> passenger airbag.

<sup>1</sup> For information on activated/deactivated airbag (SRS) see page 18



## Side airbags (SIPS bags)

## SIPS bags



Driver's seat, left-hand drive



Front passenger seat, left-hand drive

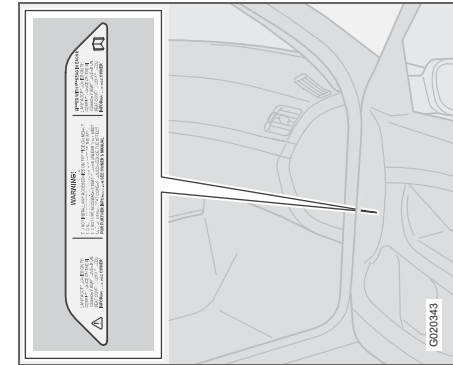

Location of airbag decal in door opening on front passenger side

The SIPS bag system consists of side airbags and sensors. A sufficiently violent collision trips the sensors and the side airbags are inflated. The airbag inflates between the occupant and the door panel and thereby cushions the initial impact. The airbag deflates when compressed by the collision. The side airbag is normally only deployed on the side of the collision.



# 01 Safety

01

## Inflatable Curtain (IC)

### Properties

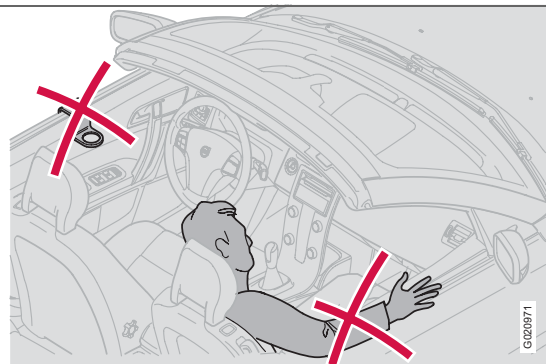
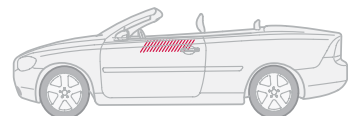
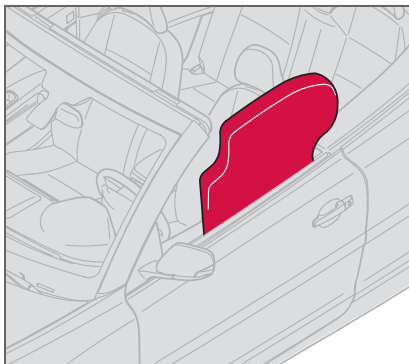

The inflatable curtain, DMIC (Door Mounted Inflatable Curtain), is a supplement to the SIPS system. It is fitted inside along the driver's and passenger side and protects both front seat occupants. The inflatable curtain is activated by sensors in the event of a sufficiently violent collision or if the car is at risk of overturning. When deployed, the inflatable curtain inflates. The inflatable curtain helps to prevent the driver and front seat passenger from striking their heads on the inside of the car during a collision. The inflatable curtain is deployed irrespective of whether the roof is open or closed.

### WARNING

Do not screw or fit anything to the headlining, door pillars or side panels. This could compromise the intended protection. Only use Volvo genuine parts that are approved for placement in these areas.

### WARNING

Do not load the car higher than 50 mm under the top edge of the side windows. Otherwise, the intended protection of the inflatable curtain, which is concealed in the headlining, may be compromised.

### WARNING

The inflatable curtain is a supplement to the seatbelts.  
Always use a seatbelt.



## Protection against whiplash injury – WHIPS

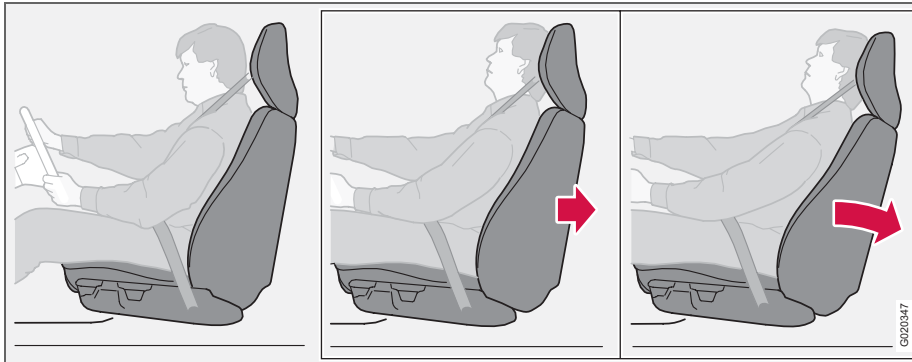

The whiplash protection system (WHIPS) consists of energy absorbing backrests and specially designed head restraints for the front seats. The system is actuated by a rear-end collision, where the angle and speed of the collision, and the nature of the colliding vehicle all have an influence.

### WARNING

The WHIPS system is a supplement to the seatbelts. Always wear your seatbelt.

### Properties of the seat

When the WHIPS system is deployed, the front seat backrests fall backward to alter the position of the driver and front seat passenger. This diminishes the risk of whiplash injury.

### WARNING

Never modify or repair the seat or WHIPS system yourself. Contact an authorised Volvo workshop.

### WHIPS system and child seats/booster cushions

The WHIPS system does not diminish the protection provided by the car to children seated in a child seat or on a booster cushion.

### Correct seating position

For the best possible protection, the driver and front seat passenger should sit in the centre of the seat with as little space as possible between the head and the head restraint.





## WHIPS

### Do not obstruct the WHIPS system

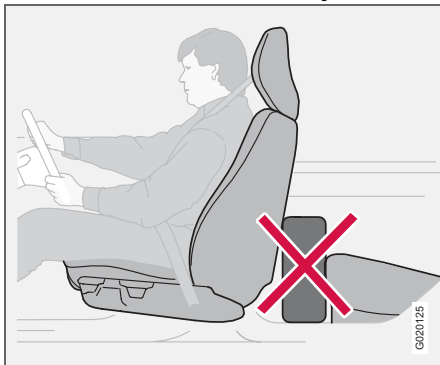

### WARNING

If a seat has been subjected to extreme forces, such as due to a rear-end collision, the WHIPS system must be checked by an authorised Volvo workshop.

Part of the WHIPS system's protective capacity may have been lost even if the seat appears to be undamaged.

Contact an authorised Volvo workshop to have the system checked after even a minor rear-end collision.



### WARNING

Do not squeeze rigid objects between the rear seat cushion and the front seat backrest. Make sure you do not obstruct the function of the WHIPS system.



## Roll-Over Protection System (ROPS)

01

### ROPS function

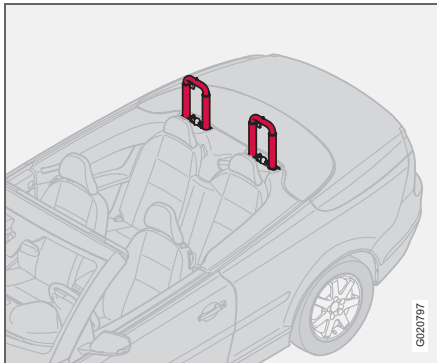

*Roll bars in raised position.*

The ROPS system consists of strong roll bars which are located behind the passengers' head restraints, as well as sensors. In the event of a situation where the car is at risk of overturning, or in the event of a sufficiently violent collision from behind, the sensors detect this and the roll bars rise up behind the passengers' heads. The roll bars are deployed irrespective of whether the roof is open or closed.

Always contact an authorised Volvo workshop if the ROPS system has deployed.



### WARNING

Do not carry out any work on the ROPS system.

Do not place any objects on the ROPS system or behind the passengers' head restraints.



# 01 Safety

01

## When the systems deploy

System	Triggered
Seatbelt tensioner, front seat	In a frontal collision and/or side-impact accident and/or rear-end collision and/or overturning.
Seatbelt tensioner, rear seat	In a frontal collision and/or side-impact accident and/or overturning.
Airbags (SRS)	In a frontal collision <sup>1</sup>
Side airbags (SIPS)	In a side-impact accident <sup>1</sup>
Inflatable Curtain DMIC	In a side-impact accident and/or overturning <sup>1</sup>
Whiplash protection WHIPS	In a rear-end collision.
Roll-Over Protection System (ROPS)	In the event of overturning and/or collision from behind.

<sup>1</sup>The bodywork of the car could be greatly deformed in a collision without airbag deployment. A number of factors such as the rigidity and weight of the object hit, the speed of the car, the angle of the collision etc. affects how the different safety systems of the car are activated.

If the airbags have been deployed, the following is recommended:

- Have the car transported to an authorised Volvo workshop. Do not drive with deployed airbags.
- Let an authorised Volvo workshop replace components in the car's safety system.
- Always contact a doctor.

### NOTE

The SRS, SIPS, DMIC, belt tensioner and ROPS systems are deployed only once during a collision.

### WARNING

The airbag system control module is located in the centre console. If the centre console is drenched with water or other liquid, disconnect the battery cables. Do not attempt to start the car since the airbags may deploy. Have the car transported to an authorised Volvo workshop.

### WARNING

Never drive with deployed airbags. They can make steering difficult. Other safety systems may also be damaged. The smoke and dust created when the airbags are deployed can cause skin and eye irritation after intensive exposure. In case of irritation, wash with cold water. The rapid deployment sequence and airbag fabric may cause friction and skin burns.



## Crash mode

## Driving after a collision

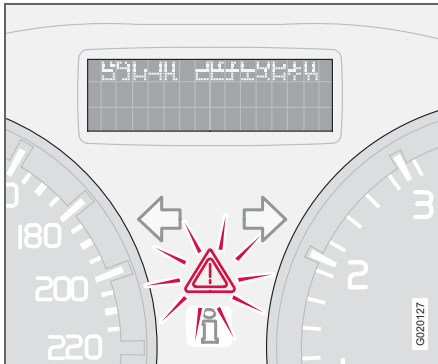

If the car is involved in a collision, the text **CRASH MODE - SEE MANUAL** may appear on the information display. This means that the car has reduced functionality. Crash mode is a protective state that is enforced when the collision may have damaged the car's vital functions, such as the fuel lines, sensors for one of the safety systems, or the brake system.

## Attempting to start the car

First, check that no fuel is leaking from the car. There should be no smell of fuel.

If everything seems normal and you have checked for indications of fuel leakage, you may attempt to start the car.

Firstly, remove the ignition key and then reinsert it. The car's electronics will then try to reset themselves to normal mode. Then try to start the car. If **CRASH MODE** is still shown on the display then the car must not be driven or towed. Even if the car appears to be driveable, hidden damage may make the car impossible to control once moving.

## Moving the car

If **NORMAL MODE** is shown after **CRASH MODE** has been reset, the car can be moved carefully out of a dangerous position. Do not move the car further than necessary.

**WARNING**

Never attempt to repair your car or reset the electronics yourself if the car has been in crash mode. This could result in personal injury or the car not functioning as normal. Always allow an authorised Volvo workshop to check and restore the car to **NORMAL MODE** after **CRASH MODE** has been displayed.

**WARNING**

Never, under any circumstances, attempt to restart the car if it smells of fuel when the **CRASH MODE** message is displayed. Leave the car at once.

**WARNING**

If the car is in **CRASH MODE** it must not be towed. It must be transported to an authorised Volvo workshop.



## Child safety

### Children should sit comfortably and safely

The position of a child in the car and the choice of equipment is dictated by the child's weight and size. For more information see page 30.

#### NOTE

Regulations regarding the placement of children in cars vary from country to country. Check what laws apply.

Children of all ages and sizes must always sit correctly secured in the car. Never allow a child to sit on the knee of a passenger.

Volvo's own child safety equipment is designed for your car. Use Volvo genuine equipment to best ensure that the mounting points and attachments are correctly positioned and are sufficiently strong.

#### NOTE

If problems arise when fitting child safety products, contact the manufacturer for clearer instructions.

### Child seats

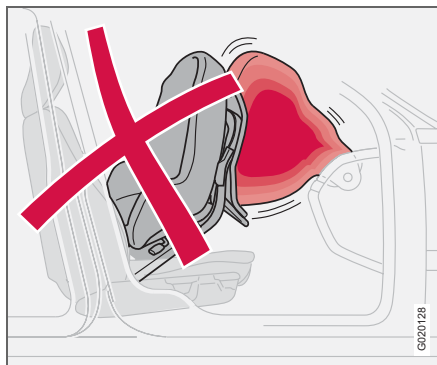

*Child seats and airbags are not compatible.*

Volvo has child safety products that are designed for and tested by Volvo.

#### NOTE

When using child safety products it is important to read the installation instructions included with the product.

Do not attach the straps for the child seat to the horizontal adjustment bar, springs, rails or beams under the seat. Sharp edges can damage the straps. Allow the backrest of the child seat to rest against the dashboard. This

applies to cars without a passenger airbag, or where the airbag is deactivated.

### Location of child seats

You may place:

- a child seat or booster cushion on the front passenger seat, provided the passenger airbag is not activated<sup>1</sup>.
- a rear-facing child seat in the rear seat that uses the back of the front seat as support.

Child seats and activated airbags are not compatible.

Always place a child in the rear seat if the passenger airbag is activated. A child in the front passenger seat could suffer serious injury if the airbag deploys.



### WARNING

Never place a child in a child seat or on a booster cushion in the front seat if the airbag (SRS) is activated.

No one shorter than 140 cm should sit in the front passenger seat if the airbag (SRS) is activated.

Failure to follow the advice given above can endanger the life of the child.

<sup>1</sup> For information on activated/deactivated airbag (SRS) see page 18.

**WARNING**

Booster cushions/child seats with steel braces or some other design that could rest on the seatbelt buckle's opening button must not be used, as they could cause the seatbelt buckle to open accidentally. Do not allow the upper section of the child seat to rest against the windscreen.

**Airbag decal**

Decal located on instrument panel end face.



Decal located on instrument panel end face (Australia only).



## Child safety

### Placement of children in the car

With regard to other child seats your car should be included in the manufacturer's enclosed list of vehicles or be universally approved in accordance with the ECE R44 legal requirement.

Weight/age	Front seat <sup>1</sup>	Rear seat
Group 0 max 10 kg (0–9 months) Group 0+ max 13 kg	Volvo Child seat – rear-facing child seat, secured with the car's seatbelt and straps. Use a protective cushion between the child seat and the dashboard.  Type approval: E5 03135	Volvo Child seat – rear-facing child seat, secured with the car's seatbelt, support legs and straps. <sup>2</sup>  Type approval: E5 03135
	Britax Baby Safe Plus – rear-facing child seat, secured with the ISOFIX fixture system.  Type approval: E1 03301146	Britax Baby Safe Plus – rear-facing child seat, secured with the ISOFIX fixture system.  Type approval: E1 03301146
Group 1 9–18 kg (9–36 months)	Volvo Child seat – rear-facing child seat, secured with the car's seatbelt and straps. Use a protective cushion between the child seat and the dashboard.  Type approval: E5 03135	Volvo Child seat – rear-facing child seat, secured with the car's seatbelt, support legs and straps. <sup>2</sup>  Type approval: E5 03135
	Britax Freeway – rear-facing child seat, secured with the ISOFIX fixture system and straps.  Type approval: E5 03171	Britax Freeway – rear-facing child seat, secured with the ISOFIX fixture system and straps. <sup>2</sup>  Type approval: E5 03171
Group 2/3 15–36 kg (3–12 yr)	Volvo Booster cushion – with or without backrest.  Type approval: E5 03139	Volvo Booster cushion – with or without backrest.  Type approval: E5 03139

<sup>1</sup>For information on activated/deactivated airbag (SRS) see page 18.

<sup>2</sup>To install a rear-facing child seat in the rear seat, contact an authorised Volvo dealer to have the mounting points installed.

**WARNING**

Never place a child in a child seat or on a booster cushion in the front seat if the airbag (SRS) is activated<sup>1</sup>.

No one shorter than 140 cm should sit in the front passenger seat if the airbag (SRS) is activated<sup>1</sup>.

Failure to follow the advice given above can endanger the life of the child.

<sup>1</sup> For information on activated/deactivated airbag (SRS) see page 18.

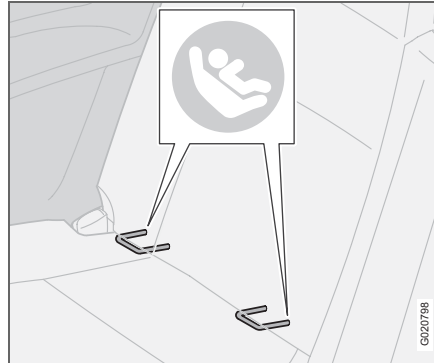
**ISOFIX fixture system for child seats (option)**

Mounting points for the ISOFIX fixture system are concealed behind the lower section of the rear seat backrest, in the outer seats.

The location of the mounting points is indicated by symbols in the backrest upholstery (see illustration above).

Press the seat cushion down to access the mounting points.

Always follow the manufacturer's installation instructions when connecting a child seat to the ISOFIX mounting points.



Overview, left-hand drive car .....	34
Overview, right-hand drive car .....	36
Driver's door control panel .....	38
Combined instrument panel .....	39
Indicator and warning symbols .....	40
Information display .....	44
Electrical socket .....	45
Lighting panel .....	46
Left-hand stalk switch .....	48
Right-hand stalk switch .....	50
Cruise control (option) .....	52
Steering wheel keypad (option) .....	53
Steering wheel adjustment, hazard warning flashers .....	54
Parking brake .....	55
Power windows .....	56
Rearview and door mirrors .....	57
Personal preferences .....	61

## INSTRUMENTS AND CONTROLS



# 02



# 02 Instruments and controls

## Overview, left-hand drive car

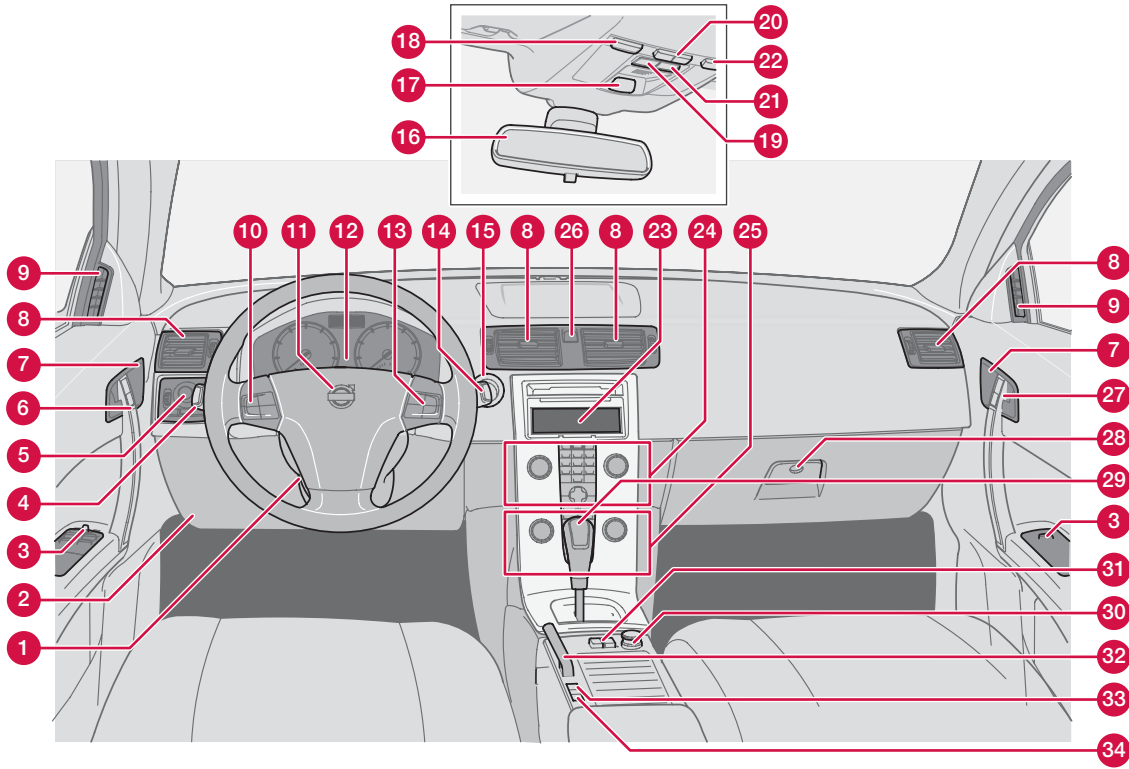

G019490



### Overview, left-hand drive car

1. Steering wheel adjustment
2. Opening handle, bonnet
3. Control panel, windows and door mirrors
4. Direction indicators, main beam, trip computer
5. Lighting panel and fuel filler flap opener
6. Door handle and lock button
7. Indicator lamp, locking
8. Air vents, dashboard
9. Air vent for side window
10. Cruise control
11. Horn and airbags
12. Combined instrument panel
13. Keypad for infotainment system
14. Windscreen wipers and washer, headlamp washers
15. Ignition switch
16. Rearview mirror, interior
17. Seatbelt reminder and passenger seat airbag indicator
18. Switch, interior lighting, left-hand side
19. Switch, alarm detectors and deadlocks
20. Switch, passenger compartment automatic lighting
21. Switch, optional equipment
22. Switch, interior lighting, right-hand side
23. Display, car settings/audio system etc.
24. Controls, car settings/audio system etc.
25. Climate control
26. Indicator lamp, hazard warning flashers
27. Door handle and lock button
28. Glovebox
29. Gear lever (manual)/gear selector (automatic)
30. Electrical socket and cigarette lighter
31. Switch, roof control
32. Parking brake
33. Blind Spot Information System, BLIS
34. Switch, optional equipment



# 02 Instruments and controls

## Overview, right-hand drive car

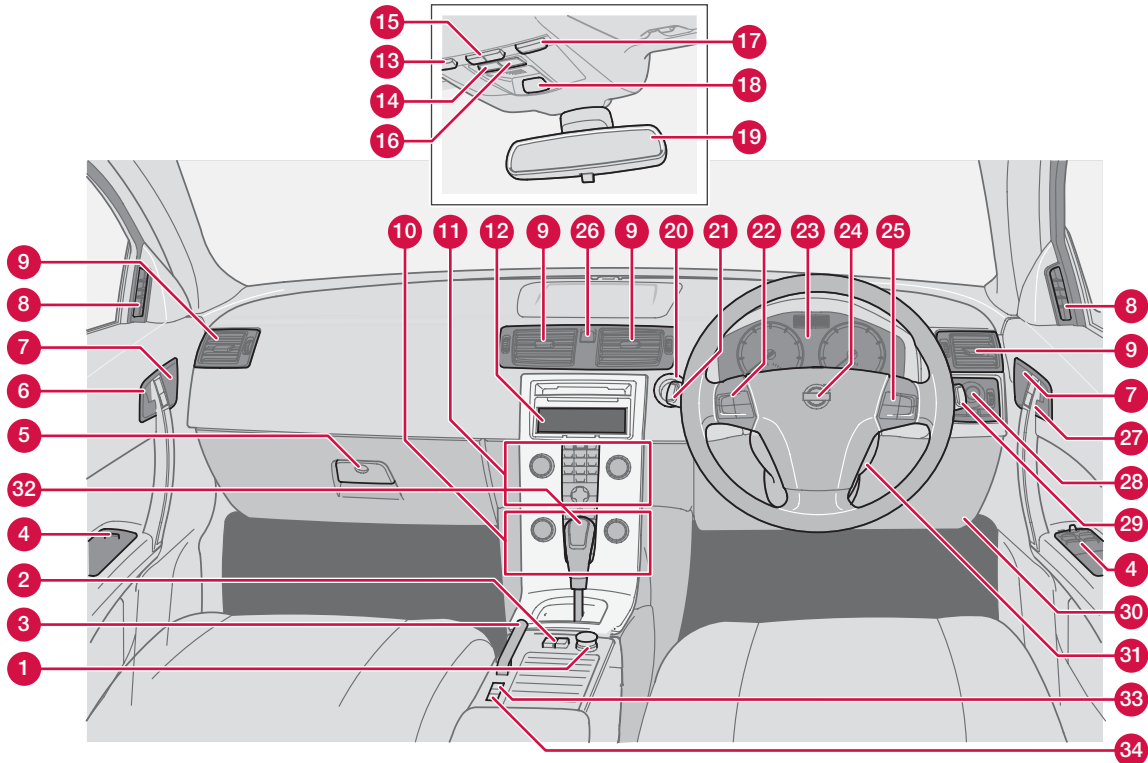

G019491

02



### Overview, right-hand drive car

1. Electrical socket and cigarette lighter
2. Switch, roof control
3. Parking brake
4. Control panel, windows and door mirrors
5. Glovebox
6. Door handle and lock button
7. Indicator lamp, locking
8. Air vent for side window
9. Air vents, dashboard
10. Climate control
11. Controls, car settings/audio system etc.
12. Display, car settings/audio system etc.
13. Switch, interior lighting, left-hand side
14. Switch, alarm detectors and deadlocks
15. Switch, passenger compartment automatic lighting
16. Switch, optional equipment
17. Switch, passenger compartment lighting, right-hand side
18. Seatbelt reminder and passenger seat airbag indicator
19. Rearview mirror, interior
20. Ignition switch
21. Stalk switch, left
22. Keypad, steering wheel, left
23. Combined instrument panel
24. Horn and airbags
25. Keypad, steering wheel, right
26. Indicator lamp, hazard warning flashers
27. Door handle and lock button
28. Lighting panel and fuel filler flap opener
29. Stalk switch, right
30. Opening handle, bonnet
31. Lever, steering wheel adjustment
32. Gear lever (manual)/gear selector (automatic)
33. Blind Spot Information System, BLIS
34. Switch, optional equipment



## Driver's door control panel

### Driver's door control panel

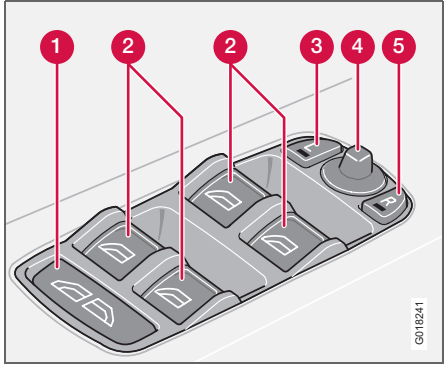

1. Power windows, all windows down/up
2. Power windows
3. Door mirror, left-hand side
4. Door mirrors, setting
5. Door mirror, right-hand side

02



### Combined instrument panel

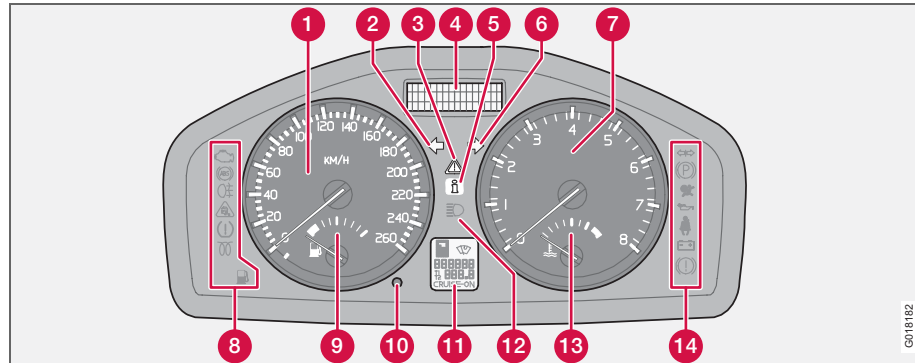

1. Speedometer.
2. Direction indicators, left.
3. Warning symbol.
4. Information display – The display presents information and warning messages and outside temperature. When the ambient temperature is between +2 C and –5 C, a snowflake symbol appears on the display. This warns of icy roads. The outside temperature gauge may show a slightly high reading after the car has been stationary.
5. Information symbol.
6. Direction indicator, right.
7. Tachometer – Indicates engine speed in thousands of revolutions per minute (rpm).
8. Indicator and warning symbols.
9. Fuel gauge.
10. Button for trip meter – Used to measure short distances. Press the button to switch between trip meters T1 and T2. Press and hold (more than 2 seconds) to zero the active trip meter.
11. Display – Display for automatic gear position, rain sensor, odometer, trip meter and cruise control.
12. Main beam indicator.
13. Temperature gauge – Displays the temperature of the engine cooling system. A message will appear on the display if the temperature becomes too high and the gauge goes into the red zone. Bear in mind that extra lights placed in front of the air intake, for example, reduce the cooling capacity at high outside temperatures and high engine loads.
14. Indicator and warning symbols.





## Indicator and warning symbols

### Functionality check, symbols

All indicator and warning symbols<sup>1</sup> illuminate when the ignition key is turned to position II before starting. This is to check that the symbols are working. When the engine starts, all the symbols should go out except the handbrake symbol, which extinguishes when the handbrake is released.



If the engine does not start within five seconds, all symbols extinguish except the symbols for a fault in the car's emissions system and for low oil pressure. Certain symbols may have no function, depending on the car's specifications.

<sup>1</sup> For certain engine variants, the symbol for low oil pressure is not used. Warnings are given via display text, see page 182.

### Symbols in the centre of the instrument panel

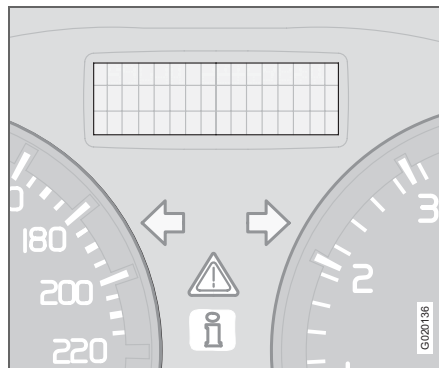

The red warning symbol illuminates when a fault has been indicated which could affect the safety and/or driveability of the car. An explanatory text is shown on the information display at the same time. The symbol remains visible until the fault has been rectified but the text message can be cleared with the **READ** button, see page 44. The warning symbol can also illuminate in conjunction with other symbols.

1. Stop in a safe place. Do not drive the car further.

2. Read the information on the information display. Implement the action in accordance with the message in the display. Clear the message using **READ**.

If the car is driven at a speed higher than 7 km/h then the warning symbol illuminates.



When one of the car's systems does not behave as intended, the yellow information symbol illuminates and a text appears in the information display. The message text is cleared using the **READ** button, see page 44, or disappears automatically after a period of time (time depending on which function is indicated).

The yellow information symbol can also illuminate in conjunction with other symbols.

If the car is driven at a speed lower than 7 km/h then the information symbol illuminates.

### **i** NOTE

When a service message is shown, the symbol and message are cleared using the **READ** button, or disappear automatically after a time.



## Indicator and warning symbols

### Indicator symbols – left-hand side

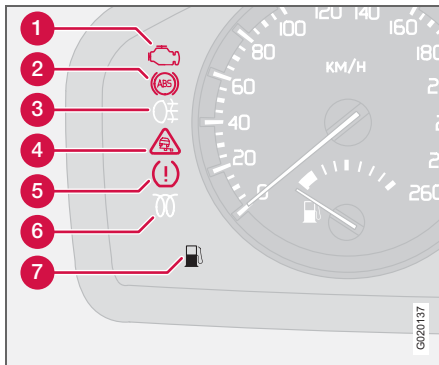

#### 1. Fault in car's emissions system

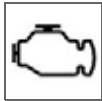

Drive to an authorised Volvo workshop to have the system checked.

#### 2. ABS fault



If this symbol lights, the system is not working. The car's regular brake system continues to work, but without the ABS function.

- Stop the car in a safe place and turn off the engine.
- Restart the engine.

- Drive to an authorised Volvo workshop to have the ABS checked if the symbol remains illuminated.

#### 3. Rear fog lamp

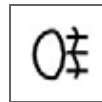

This symbol is illuminated when the rear fog lamp is on.

#### 4. Stability system STC or DSTC



For information on the system's functions and symbols, see page 130.

#### 5. No function

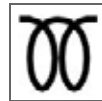

#### 6. Engine preheater (diesel)

This symbol is illuminated during engine preheating. Preheating occurs when the temperature is below  $-2^{\circ}\text{C}$ . The car can be started once the symbol extinguishes.

#### 7. Low level in fuel tank



This symbol illuminates when there are approximately 8 litres of usable fuel left in a petrol-engined car, or approximately 7 litres in a diesel-engined car.

## Indicator and warning symbols

### Indicator symbols – right-hand side

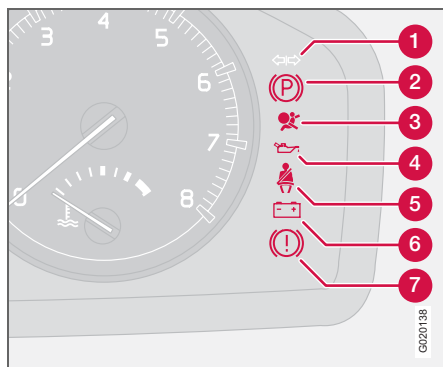

#### 1. Indicator symbol for trailer

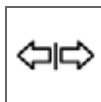

This symbol flashes when the direction indicators are used and a trailer is coupled. If the symbol does not flash, one of the lamps on the trailer or the car is

defective.

#### 2. Parking brake applied



The symbol illuminates when the parking brake is applied. Always pull the parking brake lever to the end position.

#### NOTE

The symbol illuminates irrespective of how hard the parking brake is applied.

#### 3. Airbags – SRS



If this symbol remains on or illuminates while driving, it means a fault has been detected in the seatbelt buckle, SRS, SIPS, or IC system. Drive directly to an

authorised Volvo workshop to have the system checked.

#### 4. Low oil pressure<sup>1</sup>

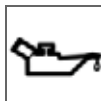

If this symbol illuminates while driving, the engine oil pressure is too low. Stop the engine immediately and check the engine oil level, top up if necessary. If the

symbol illuminates and the oil level is normal, contact an authorised Volvo workshop.

#### 5. Seatbelt reminder



This symbol illuminates if someone in a front seat has not put on their seatbelt or if someone in a rear seat has taken off their seatbelt.

#### 6. Alternator not charging

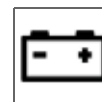

If this symbol illuminates while driving, a fault has occurred in the electrical system. Contact an authorised Volvo workshop.

#### 7. Fault in brake system



If this symbol lights, the brake fluid level may be too low.

- Stop the car in a safe place and check the level in the brake fluid reservoir, see page 185. If the level in the reservoir is below MIN, the car should not be driven any further. Transport the car to an authorised Volvo workshop to have the brake system checked.

<sup>1</sup> For certain engine variants, the symbol for low oil pressure is not used. Warnings are given via display text, see page 182.



## Indicator and warning symbols

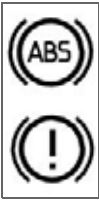

If the BRAKE and ABS symbols illuminate at the same time, there may be a fault in the brake force distribution system.

- Stop the car in a safe place and turn off the engine.
- Restart the engine.
- If both symbols extinguish, continue driving.
- If the symbols remain on, check the level in the brake fluid reservoir. See page 185.
- If the brake fluid level is normal but the symbols are still illuminated, the car can be driven, with great care, to an authorised Volvo workshop to have the brake system checked.
- If the level in the reservoir is below **MIN** then the car should not be driven any further. Have the car transported to an authorised Volvo workshop to have the brake system checked.

### **WARNING**

If the BRAKE and ABS symbols are illuminated at the same time, there is a risk that the rear end will skid during heavy braking.

### Reminder – doors not closed

If one of the doors, the bonnet <sup>1</sup> or the boot lid is not properly closed, the driver will be reminded of this.

#### Low speed



If the car is travelling at a speed lower than approx. 7 km/h, the information symbol will illuminate and one of the following texts will be shown on the display: **DRIVER DOOR OPEN, PASSENGER DOOR OPEN, or ENGINE HOOD OPEN.**

Stop the car safely as soon as possible and close the door or bonnet.

#### High speed



If the car is moving faster than approx. 7 km/h, the symbol illuminates and one of the texts indicated in the previous paragraph appears in the display.

#### Boot lid reminder



If the boot lid is open, this information symbol will illuminate and **BOOT LID OPEN** will appear on the display.

<sup>1</sup> Only cars with alarms

## Information display

### Messages

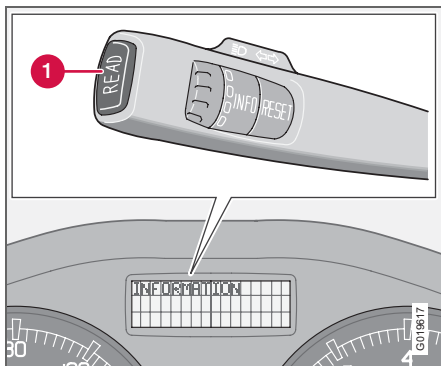

When a warning or indicator symbol illuminates, a message appears on the information display.

- Press the **READ** button (1).

Switch between messages with the **READ** button. Fault messages are stored in the memory until the fault is rectified.

#### NOTE

If a warning message appears while you are using the trip computer, the message must be read (press **READ**) before the previous activity can be resumed.

Message	Specification
STOP SAFELY	Stop the car in a safe manner and turn off the engine. Serious risk of damage.
STOP ENGINE	Stop the car in a safe manner and turn off the engine. Serious risk of damage.
SERVICE URGENT	Have the car checked by an authorised Volvo workshop immediately.
SEE MANUAL	Read the owner's manual.
SERVICE REQUIRED	Have the car checked by an authorised Volvo workshop as soon as possible.
BOOK TIME FOR REGULAR SERVICE	Time to book regular service at an authorised Volvo workshop.
TIME FOR REGULAR SERVICE	Time for regular service at an authorised Volvo workshop. The timing is determined by the number of kilometres driven, number of months since the last service, engine running time and oil grade.
MAINTENANCE OVERDUE	If the service interval is not followed then the warranty does not cover any damaged parts. Contact an authorised Volvo workshop for service.
CHECK OIL LEVEL	Check the oil level. The message is shown every 10 000 km (certain engine variants). For information on checking the oil level, see page 183.
SOOT FILTER FULL – SEE MANUAL	Diesel particle filter requires regeneration, see page 120.
DSTC SPIN CONTROL OFF	The function of the stability and traction control system is reduced, see page 131 for more variants.

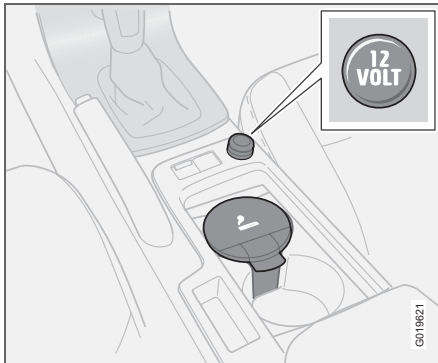
**Electrical socket****12 V electrical socket**

The electrical socket can be used for 12 V accessories, such as mobile phone chargers and coolers. The maximum current is 10 A. For the socket to supply current, the ignition key must be in at least position I.

**WARNING**

Always leave the plug in the socket when the socket is not in use.

**Cigarette lighter (option)**

Activate the lighter by pushing in the button. The button pops out when the lighter is hot. Pull out the lighter and light a cigarette on the heated coils.

02

## Lighting panel

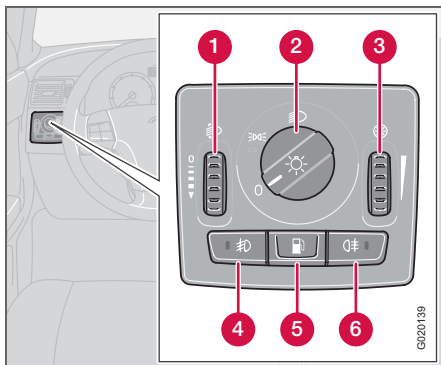

Position	Specification
0	Automatic/deactivated dipped beam. Only main beam flash.
	Position/parking lamps
	Automatic dipped beam. Main beam and main beam flash work in this position.

### Headlamp levelling

The load in the car changes the vertical alignment of the headlamp beam, which could dazzle oncoming motorists. Avoid this by adjusting the height of the beam.

- Turn the ignition key to position **II**.
- Turn the headlamp control (2) to one of the end positions.
- Roll the control (1) up or down respectively to raise or lower beam alignment.

Cars with Bi-Xenon headlamps<sup>1</sup> have automatic headlamp levelling, so there is no control (1).

### Position/parking lamps

Position/parking lamps can be switched on irrespective of ignition key position.

- Turn the headlamp control (2) to the centre position.

When the ignition key is in position **II** the position/parking lamps and number plate lighting are always on.

### Headlamps

#### Automatic dipped beam (certain countries)

Dipped beam comes on automatically when the ignition key is turned to position **II**, except when the headlamp control (2) is in

<sup>1</sup> Option

the centre position. If necessary, the automatic dipped beam can be deactivated by an authorised Volvo workshop.

#### Automatic dipped beam, main beam

- Turn the ignition key to position **II**.
- Dipped beam is activated by means of turning the headlamp control (2) clockwise to the end position.
- Main beam is activated by means of moving the left-hand stalk switch towards the steering wheel to the end position and releasing it, see page 48.

The lamps are switched off automatically when the ignition key is turned to position **I** or **0**.

### Instrument lighting

The instrument lighting is switched on when the ignition key is in position **II** and the headlamp control (2) is in one of the end positions. The lighting is automatically dimmed during the day and can be controlled manually at night.

- Roll the control up or down (3) for brighter or dimmer lighting.

### Enhanced display lighting

To facilitate reading the odometer, trip meter, clock and outside temperature gauge, these illuminate when the car is unlocked and when the key is removed from the ignition switch.



The displays extinguish when the car is locked.

### Fog lamp

<b>i</b>	<b>NOTE</b>
Regulations for use of fog lamps vary from country to country.	

### Front fog lamps (option)

The front fog lamps can be switched on along with the headlamps or the position lamps/parking lamps.

- Press the button (4).

The light in the button (4) illuminates when the front fog lamps are switched on.

### Rear fog lamp

The rear fog lamp can only be switched on with the headlamps or the front fog lamps.

- Press the button (6).

The rear fog lamp indicator symbol on the combined instrument panel and the light in the button (6) illuminate when the rear fog lamp is switched on.

### Fuel filler flap

Press button (5) to open the fuel filler flap when the car is unlocked, see page 106.

### Brake light

The brake light automatically comes on during braking.

### Emergency brake light and automatic hazard warning flashers, EBL<sup>1</sup>

Emergency Brake Lights (EBL) are activated in the event of heavy braking or if the ABS brakes are activated. This function means that the brake light flashes to immediately alert cars travelling behind.

The system is activated if ABS is used for more than 0.5 seconds or in the event of heavy braking, however, only when braking from speeds above 50 km/h. When the speed of the car is lower than 30 km/h the brake lights shine normally again and the hazard warning flashers are switched on automatically. The hazard warning flashers remain on until the car accelerates again but can be deactivated with the button for hazard warning flashers, see page 54.

<sup>1</sup> Certain markets



## Left-hand stalk switch

### Stalk switch positions

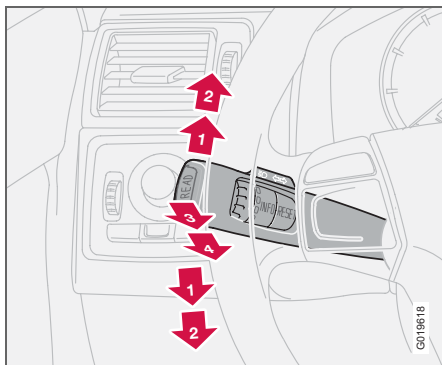

1. Short flash sequence, direction indicators
2. Continuous flash sequence, direction indicators
3. Main beam flash
4. Switching, main and dipped beam, and home safe lighting

### Direction indicators

#### Continuous flash sequence

- Move the stalk switch up or down to end position (2).

The stalk switch remains in its end position and is moved back manually, or automatically by steering wheel movement.

#### Short flash sequence

- Move the stalk switch up or down to position (1) and release.

The direction indicators flash three times and the stalk switch returns to its home position.

#### Switching, main and dipped beam

The ignition key must be in position II for main beam to be switched on.

- Turn the headlamp control clockwise to the end position, see page 46.
- Move the stalk switch towards the steering wheel to the end position (4) and release.

#### Main beam flash

- Move the stalk switch gently towards the steering wheel to position (3).

Main beam comes on until the stalk switch is released. Main beam flash only works when the ignition key is inserted in the ignition switch.

#### Home safe lighting

Some exterior lights can be kept on and serve as home safe lighting after the car has been locked. The standard delay is 30 seconds,<sup>1</sup> but can be changed to 60 or 90 seconds. See page 62.

<sup>1</sup> Factory sett.

- Remove the key from the ignition switch.
- Move the stalk switch towards the steering wheel to the end position (4) and release.
- Get out of the car and lock the door.



## Left-hand stalk switch

### Trip computer (option)

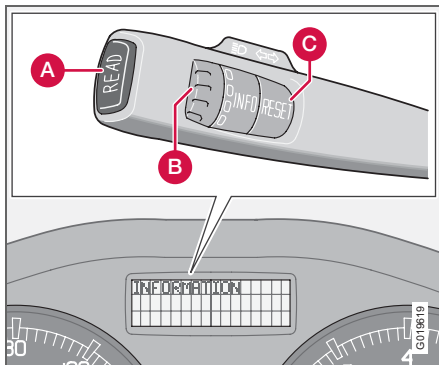

### Controls

To scroll through trip computer information, turn the thumbwheel (B) in steps, either upward or downward. Continue turning to return to the starting point.

#### **i** NOTE

If a warning message interrupts while you are using the trip computer, this message must be acknowledged. Acknowledge by pressing the **READ** button (A) and revert to the trip computer function.

### Functions

The trip computer displays the following information:

- **AVERAGE SPEED**
- **ACTUAL SPEED MPH**
- **INSTANTANEOUS**
- **AVERAGE**
- **KILOMETRES TO EMPTY TANK**
- **DSTC**, see page 130

### AVERAGE SPEED

When the ignition is switched off, the average speed is stored and used as the basis of the new value when you continue driving. Reset using the **RESET** button (C).

### ACTUAL SPEED MPH<sup>1</sup>

Current speed is displayed in mph.

### INSTANTANEOUS

Current fuel consumption is calculated every second. The information on the display is updated every couple of seconds. When the car is stationary, "----" appears on the display. During the period for regeneration<sup>2</sup> fuel consumption may increase, see page 120.

<sup>1</sup> Certain countries

<sup>2</sup> Only applies to diesel cars with particle filter.

### AVERAGE

The average fuel consumption is stored when the ignition is switched off and remains until the function is reset. Reset using the **RESET** button (C).

#### **i** NOTE

There may be a slight error in the reading if a fuel-driven heater is used.

### KILOMETRES TO EMPTY TANK

The range to empty is calculated based on the average fuel consumption over the last 30 km. When the range to empty is shorter than 20 km then "----" is shown on the display.

#### **i** NOTE

There may be a slight error in the reading if fuel consumption is changed due to a change in driving style or if a fuel-driven heater is used for example.

### Resetting

- Select **AVERAGE SPEED** or **AVERAGE**
- Press and hold the **RESET** button (C) for at least five seconds to reset the average speed and average consumption at the same time.

## Right-hand stalk switch

### Windscreen wipers

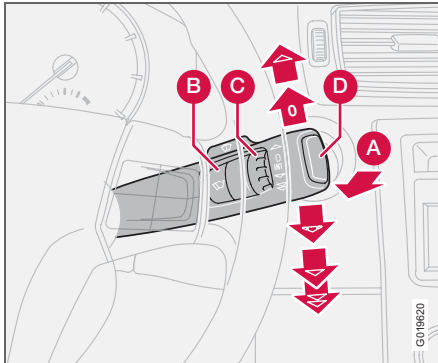

- A. Windscreen and headlamp washers
- B. Rain sensor – On/Off
- C. Thumbwheel
- D. No function

### Windscreen wipers off



The windscreen wipers are off when the stalk switch is in position **0**.

### Single sweep

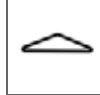

Raise the stalk switch to make a single sweep.

### Intermittent wiping



You can adjust and set a suitable speed for intermittent wiping. Turn the thumbwheel (C) up for a shorter interval between sweeps. Turn it down to increase the

delay.

### Continuous wiping

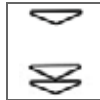

The wipers sweep at normal speed.

The wipers sweep at high speed.

### ! IMPORTANT

Before activating the wipers during winter - ensure that the wiper blades are not frozen in and that any snow or ice on the windscreen is scraped away.

### ! IMPORTANT

Use plenty of washer fluid when the wipers are cleaning the windscreen. The windscreen must be wet when the windscreen wipers are operating.

### Windscreen/headlamp washer

Pull the stalk switch towards the steering wheel to start the windscreen and headlamp washers. The wipers will make several extra sweeps once the stalk is released.

### High-pressure headlamp washing (option in certain markets)

High-pressure headlamp washing consumes a large quantity of washer fluid. To save fluid, the headlamps are washed as follows.

Dipped beam selected with the switch on lighting panel:

The headlamps are washed the first time the windscreen is washed. Within the next ten minutes, they are washed every fifth wash of the windscreen. If more than ten minutes passes between washes, the headlamps are washed every time.

Parking/position lamps selected with the switch on the lighting panel:

- Bi-Xenon headlamps are only washed every fifth wash cycle irrespective of the time that elapses.

- Halogen headlamps are not washed.

The switch on the lighting panel is in position **0**:

- Bi-Xenon headlamps are only washed every fifth wash cycle irrespective of the time that elapses.

- Halogen headlamps are not washed.



## Right-hand stalk switch

### Rain sensor (option)

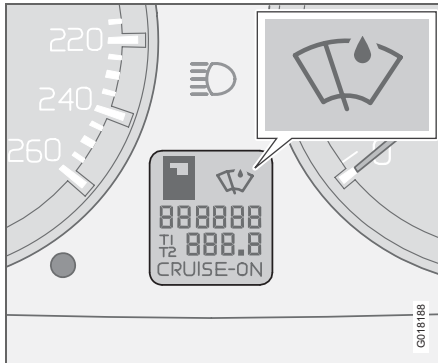

The rain sensor automatically activates the windscreen wipers based on how much water it detects on the windscreen. The sensitivity of the rain sensor can be adjusted using the thumbwheel (C).

Turn the thumbwheel upwards for higher sensitivity and downwards for lower sensitivity, (an extra sweep is made when the thumbwheel is turned upwards).

#### On/Off

When activating the rain sensor, the ignition key must be in position **I** or **II** and the windscreen wiper stalk switch must be in position **0** (not activated).

Activating the rain sensor:

Press the button (B). A display symbol shows that the rain sensor is active.

To turn the rain sensor off, either:

- Press button (B)
- Press the stalk switch downward to another wiper program. If the stalk switch is raised, the rain sensor will remain active, the wipers make an extra sweep and then return to rain sensor mode when the stalk is released to position **0**.

The rain sensor is automatically deactivated when the key is removed from the ignition switch or five minutes after the ignition is switched off.

#### **!** IMPORTANT

At an automatic car wash: Deactivate the rain sensor by pressing the button (B) while the ignition key is in position **I** or **II**. Otherwise, the windscreen wipers could start swiping and become damaged.

#### Thumbwheel

Use the thumbwheel to adjust the frequency of wiper sweeps when intermittent wiping is selected, or the sensitivity to rain when the rain sensor is selected.

## Cruise control (option)

### Activating

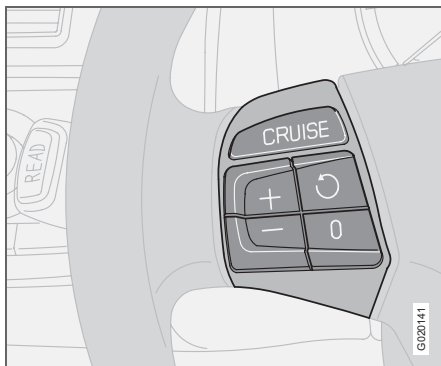

The controls for cruise control are to the left of the steering wheel.

Setting the desired speed:

- Press the **CRUISE** button. **CRUISE** is shown on the combined instrument panel.
- Touch + or – to lock the vehicle speed. **CRUISE-ON** appears on the combined instrument panel.

Cruise control cannot be engaged at speeds below 30 km/h or above 200 km/h.

### Increasing or decreasing speed

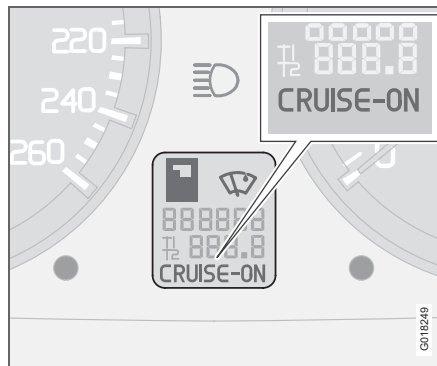

- Increase or decrease the speed by pressing and holding + or –. The speed of the car when the button is released is set as the new speed.

Pressing (less than half a second) + or – changes the speed 1 km/h or 1.6 km/h<sup>1</sup>.

#### NOTE

A temporary increase in speed (less than one minute) using the accelerator, such as while overtaking, does not affect the cruise control setting. When you release the accelerator, the car will return to the programmed speed.

<sup>1</sup> Depending on engine type

### Temporary disengagement

- Press **0** to disengage the cruise control temporarily. **CRUISE** will be shown on the combined instrument panel. The speed set earlier is stored in the memory.

The cruise control is also temporarily disengaged when:

- the brake pedal or clutch pedal is depressed
- speed falls below 25–30 km/h when travelling uphill<sup>1</sup>
- the gear selector is moved to position **N**
- wheel spin or wheel lock-up occurs
- a temporary increase in speed lasts longer than one minute.

### Return to the set speed



- Press this button to resume the previously set speed. **CRUISE-ON** appears on the combined instrument panel.

### Disengaging

- Press **CRUISE** to disengage the cruise control. **CRUISE-ON** goes out on the combined instrument panel.



## Steering wheel keypad (option)

### Button functions



The four buttons at the bottom of the steering wheel keypad control the radio and the phone. The function of a button depends on which system is active. The steering wheel keypad can be used to scroll between preset stations, change CD tracks and adjust the volume.

Press and hold one of the arrow keys to fast forward/reverse or search for the next station.

The phone must be switched on to adjust audio system settings. It must be activated with the **ENTER** key to enable control of the phone functions with the arrow keys.

To return to Audio only, press **EXIT**.



### Steering wheel adjustment, hazard warning flashers

#### Steering wheel adjustment

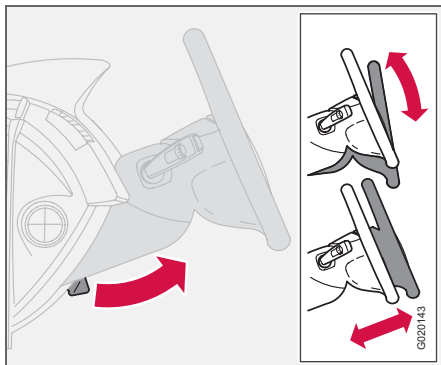

The steering wheel can be adjusted for both height and reach.

- Pull the lever towards you to release the steering wheel.
- Adjust the steering wheel to the position that suits you best.
- Push back the lever to fix the steering wheel in place. If the lever is stiff, press the steering wheel lightly at the same time as you push the lever back.

#### **WARNING**

Adjust the steering wheel before driving off, never while driving. Before driving, check that the steering wheel is fixed in position.

#### Hazard warning flashers

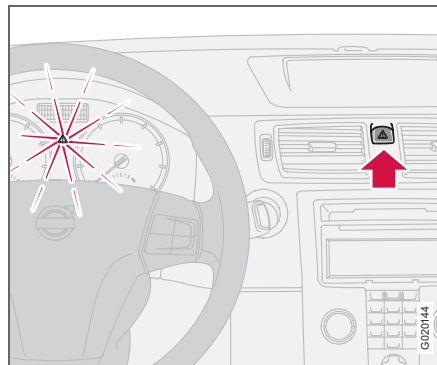

Use the hazard warning flashers (all direction indicators flash) when the car is stopped where it could be a traffic hazard or obstruction. Press the button to activate the function.

A sufficiently violent collision or heavy braking activates the hazard warning flashers automatically, see page 47. The function can be deactivated with the button.

#### **NOTE**

Regulations regarding the use of hazard warning flashers vary from country to country.



## Parking brake

### Parking brake (handbrake)

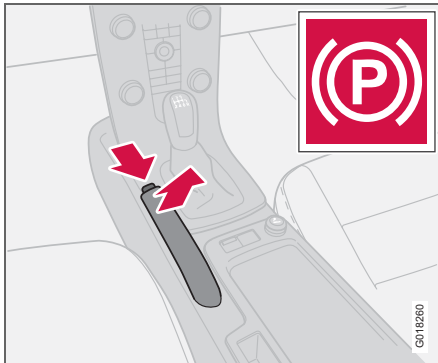

The lever is located between the front seats.

#### **i** NOTE

The warning lamp symbol in the combined instrument panel illuminates irrespective of how hard the parking brake is applied.

### How to Apply the parking brake

- Press the foot brake pedal down firmly.
- Pull up the parking brake lever up firmly to its full extent.
- Release the foot brake pedal and make sure that the car is at a standstill position.

- If the vehicle rolls, the parking brake lever must be pulled more firmly.
- When parking a vehicle always put the gear selector in **1** st gear (for manual transmission) or **P** (for automatic transmission).

### Parking on a hill

If the car is parked facing uphill; turn the wheels away from the kerb.

If the car is parked facing downhill; turn the wheels toward the kerb.

### How to release the parking brake

- Press the foot brake pedal down firmly.
- Pull the parking brake lever up slightly, press the button, release the parking brake lever and release the button.





## Power windows

### Operation

The power windows are operated using the controls in the doors. The ignition key must be in position **I** or **II** for the power windows to operate.

The windows continue to work for a limited amount of time when the car is stopped and ignition key is removed, provided none of the doors is opened. Operate the windows with caution.

To open a window:

- Depress the front of the control.

To close a window:

- Raise the front of the control.

### Remote control and lock buttons

To operate the power windows with lock buttons and remote control, see page 106.

#### **WARNING**

Make sure that children and other passengers cannot be trapped in any way when closing the windows. Pay close attention if the rear door windows are controlled from the driver's door.

The driver can operate all of the power windows from the driver's seat.

### Driver's door

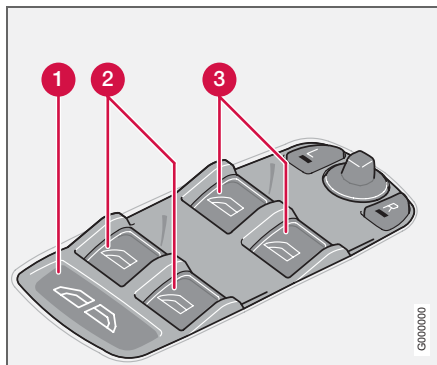

*Driver's door control panel.*

The windows can be opened and closed in two ways:

### Manual operation

Depress one of the controls (2) or (3) gently or raise it gently. The power window opens or closes as long as the switch is actuated.

### Automatic operation

Fully depress one of the controls (3) or raise it, then release. The side window will then open or close automatically. If the window is obstructed by an object, the movement will

stop. Only the front windows can be closed automatically.

The control on the passenger door is operated in the same way as on the driver's door.

### All windows simultaneously

All windows can be opened and closed simultaneously using button (1). The windows are opened automatically with a short press on the right-hand side of the button. Close by keeping the left-hand side of the button pressed in.

#### **WARNING**

The function that interrupts the movement of the windows in the event of blocking works with both automatic and manual closing, although not after the deployment of pinch protection.

#### **WARNING**

If there are children in the car:

Remember to switch off the supply to the power windows by removing the ignition key if the driver leaves the car.

Make sure that children and other passengers cannot be trapped in any way when closing the windows.



## Rearview and door mirrors

## Interior rearview mirror

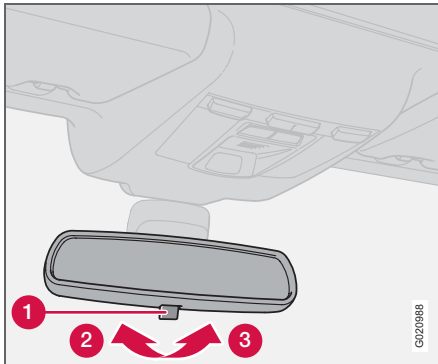

Bright light from behind could be reflected in the rearview mirror and dazzle the driver. Use dimming when disturbed by light from behind.

## Dipping

1. Control for dimming
2. Normal position
3. Dimmed position.

## Automatic dimming (option)

Bright light from behind is automatically dimmed by the rearview mirror. The control (1) is not available in mirrors with automatic dimming.

## Rearview mirror with compass (option on certain markets)

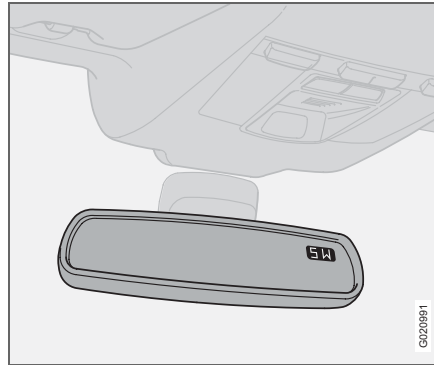

The upper right-hand corner of the rearview mirror has an integrated display that shows the compass direction in which the front of the car is pointing. Eight different directions are shown with English abbreviations: **N** (north), **NE** (north east), **E** (east), **SE** (south east), **S** (south), **SW** (south west), **W** (west) and **NW** (north west).

## Calibrating the compass

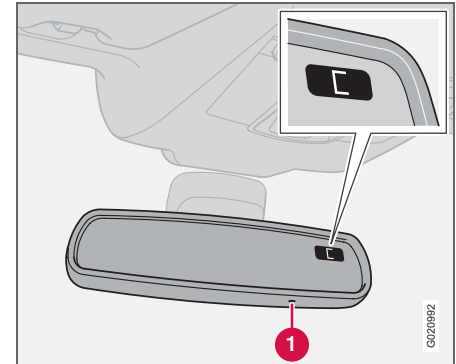

The earth is divided into 15 magnetic zones. The compass is set for the geographical area to which the car was delivered. The compass should be calibrated if the car is moved across several magnetic zones.

- Stop the car in a wide open area with the engine running at idling speed.
- Press and hold button (1) for at least 6 seconds. Following which, the sign **C** is shown (the button is concealed, so use a paper clip for example to press it in).
- Press and hold button (1) for at least 3 seconds. The number for the current magnetic zone is displayed.



# 02 Instruments and controls

## Rearview and door mirrors

- Press the button (1) repeatedly until the number for the required magnetic zone (1-15) is shown, refer to the map of magnetic zones for the compass.
- Wait until the display returns to showing the character C.
- Following which, press and hold the button for 9 seconds and select L for left-hand drive cars and R for right-hand drive.
- Drive slowly in a circle with a maximum speed of 10 km/h until a compass direction is shown on the display, which indicates that the calibration is complete.

02

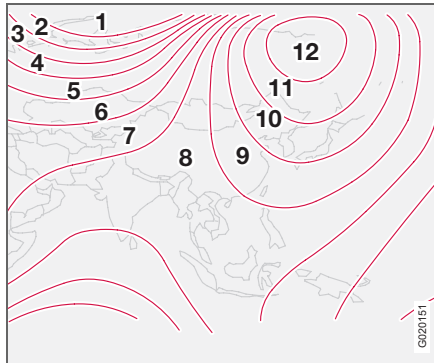

Magnetic zones, Asia



Magnetic zones, Australia

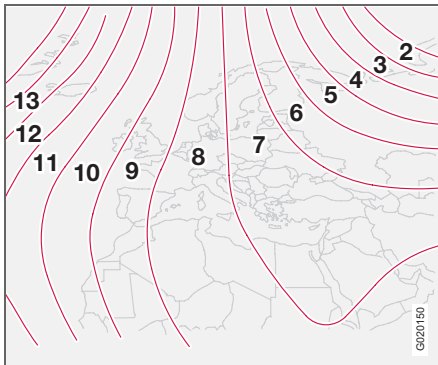

Magnetic zones, Europe



Magnetic zones, South America

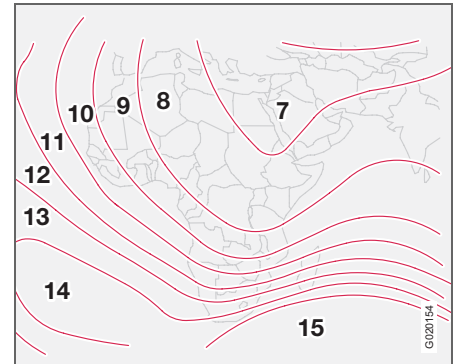

Magnetic zones, Africa

## Rearview and door mirrors

### Door mirrors

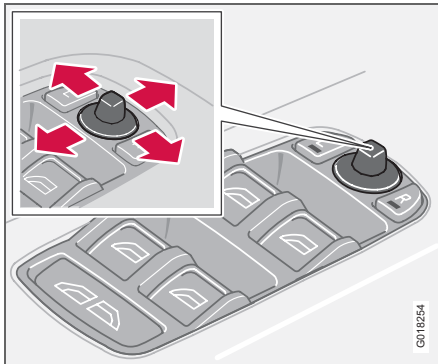

The controls for adjusting the two door mirrors are at the front of the driver's door armrest. The rearview mirrors can be operated in ignition position **I** and **II**.

- Press the **L** button for the left-hand door mirror or **R** for the right-hand door mirror. The light in the button illuminates.
- Adjust the position with the joystick in the centre.
- Press the **L** or **R** button again. The light goes out.

### Retractable power door mirrors (option)

The mirrors can be retracted for parking and driving in narrow spaces. This can be done in ignition position **I** and **II**.

#### Retracting the mirrors

- Press the **L** and **R** button at the same time.
- Release the buttons. The mirrors automatically stop in the fully retracted position.

#### **!** IMPORTANT

Do not use a scraper to remove ice from the mirrors as this could scratch the glass and the water and dirt-repellent coating<sup>1</sup> could be damaged. Use the defroster function instead, see page 70.

<sup>1</sup>Option

#### **!** WARNING

Both door mirrors are the wide angled type to provide optimal vision. Objects may appear further away than they actually are.

#### Folding out the mirrors

- Press the **L** and **R** button at the same time.

- Release the buttons. The mirrors automatically stop in the fully extended position.

#### Resetting to neutral

Mirrors that have been moved out of position by an external force must be reset to the neutral position for electric retracting and extending to work.

- Press the **L** and **R** button to retract the mirrors.
- Extend the mirrors again with the **L** and **R** button. The mirrors are now reset to the neutral.

#### Home safe and approach lighting

The light on the door mirrors (option) illuminates when the approach lighting or home safe lighting is activated.

#### Storing door mirror positions

The positions of the mirrors are stored when the car is locked with the remote control. When the car is unlocked with the same remote control the mirrors and the driver's seat adopt the stored positions.



### Rearview and door mirrors

#### Water and dirt-repellent coating (option)



The front side windows and/or door mirrors are treated with a coating which improves the view in poor weather conditions. For information on maintenance, see page 171.

#### Rearview and door mirrors

In certain weather conditions, the function of the dirt-repellent coating is improved if the door mirror defrosters are used, see page 70.

Heat the door mirrors:

- If they are covered with ice or snow.
- In heavy rain and dirty road conditions.
- If they are misted.



#### IMPORTANT

Do not use a metal ice scraper to remove ice from the windows. The water and dirt-repellent coating could be damaged. Use the defroster to remove ice from the mirrors. An ice scraper could scratch the mirror glass!



## Personal preferences

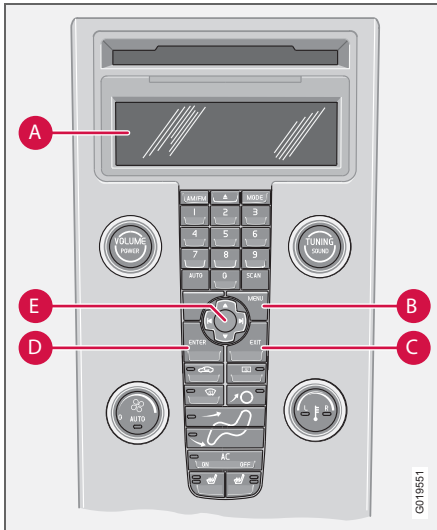

Control panel

### Possible settings

Personal preferences can be set for some of the car's functions: the locks, climate control and audio functions. For audio functions, see page 206.

#### Control panel

A. Display

B. **MENU**

C. **EXIT**

D. **ENTER**

E. Navigation

#### Use

The settings are shown on the display (A).

Open the menu to enter settings:

- Press **MENU** (B).
- Scroll, for example, to **Car Settings** with the navigation button (E).
- Press **ENTER** (D).
- Select an alternative with the navigation button (E).
- Activate your selection with **ENTER**.

Close the menu:

- Press **EXIT** (C) for approximately one second.

### Clock, adjustment

The hour and minute are each adjusted separately.

- Use the numbers on the keypad or "arrow up" or "arrow down" on the navigation button (E).
- Select the number for adjustment using "arrow right" or "arrow left" on the navigation button.
- Press **ENTER** to start the clock.

#### NOTE

If the car has a 12-hour clock then **AM/PM** is selected using "arrow up" or "arrow down" after the final minute number has been adjusted.

### Climate control settings

#### Auto blower adjust

The fan speed can be set to AUTO mode in cars equipped with ECC:

- Select from **Low**, **Normal** and **High**.

#### Recirculation timer

When the timer is active, the air recirculates for 3 – 12 minutes, depending on the outside air temperature.

- Select **On/Off** depending on whether you wish the recirculation timer to be active.



### Personal preferences

#### Reset all

Resets the climate function options to the factory settings.

#### Car settings

##### Unlock confirm. light

The hazard warning flashers can provide feedback when the car is unlocked with the remote control. This function can be turned **On or Off**.

##### Lock confirm. light

The hazard warning flashers can provide feedback when the car is locked with the remote control. This function can be turned **On or Off**.

##### Automatic locking – doors

When the speed of the car exceeds 7 km/h the doors and boot lid can be locked automatically. This function can be turned **On/Off**. Pulling the door handle twice unlocks and opens the doors from the inside.

##### Unlock doors

There are two alternatives for unlocking:

- **All doors** – one press of the remote control unlocks both doors and the boot lid.
- **Driver's door first, then all others** – one press of the remote control unlocks the

driver's door. A second press then unlocks the passenger door and the boot lid.

##### Simultaneous opening of all windows

This function can be selected for the unlock button on the remote control:

- **Auto-open all windows** – all windows are opened simultaneously with one long press on the unlock button.

##### Keyless entry (option in certain markets)

- **All doors** – both doors and the boot lid are locked or unlocked at the same time.
- **Both front doors** – both front doors are unlocked simultaneously.
- **One of the front doors** – any door or boot lid can be unlocked separately.

##### Approach lighting

Select the time the car's lights should remain on when the approach lighting button is pressed. The following alternatives are available: **30/60/90 seconds**.

##### Home safe lighting

Select the time the car's lights should remain on when the left-hand stalk switch is pulled back after the ignition key has been removed. The following alternatives are available: **30/60/90 seconds**.

#### Information

- **VIN** - (Vehicle Identification Number). The car's unique identity number.
- **Number of keys** - The number of keys registered for the car is shown.







General information on climate control .....	66
Electronic climate control, ECC .....	68
Air distribution .....	71
Fuel-driven heater (option) .....	72

## CLIMATE CONTROL



# 03



## General information on climate control

### Air conditioning

The car is equipped with electronic climate control (ECC). The climate control system controls the air conditioning (AC) and the cooling, heating and dehumidifying of the air in the passenger compartment.

#### NOTE

The air conditioning can be switched off, but to ensure the best possible air in the passenger compartment and prevent the windows from misting, it should always be on.

### Misting windows

Remove misting on the insides of the windows by first using the defroster function.

To reduce the risk of misting, clean the windows with a normal window cleaning agent.

### Ice and snow

Remove ice and snow from the climate control air intake (the grille between the bonnet and the windscreen).

### Fault tracing and repair

Entrust fault tracing and repair of the climate control system to an authorised Volvo workshop only.

### Refrigerant

The air conditioning system contains R134a refrigerant. This refrigerant contains no chlorine, which means that it is harmless to the ozone layer. The system must only be charged with R134a refrigerant. Have an authorised Volvo workshop carry out this work.

### Passenger compartment filter

All air which enters the passenger compartment is first cleaned by a filter. This filter must be replaced regularly. Follow the Volvo Service Programme for the recommended replacement intervals. If the car is used in a severely contaminated environment, it may be necessary to replace the filter more often.

#### NOTE

There are several different types of passenger compartment filter. Ensure that the correct filter is installed.

### Display

There is a display above the climate control panel that displays climate control settings.

### Personal preferences

You can set preferences for two climate control functions:

- Fan speed in **AUTO** mode (applies only to cars with ECC).
- Recirculation timer for passenger compartment air.

For information about these settings, see page 61.



## General information on climate control

### Air vents in the dashboard

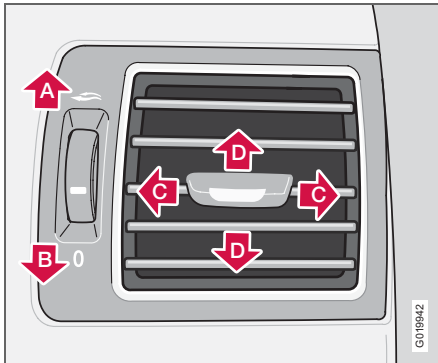

- A. Open
- B. Closed
- C. Lateral airflow
- D. Vertical airflow

Aim the outer vents towards the side windows to remove misting from the front side windows.

Cold weather: Close the centre vents for optimum comfort and best demisting.

### ECC

#### Actual temperature

The temperature you select corresponds to the physical experience with reference to factors such as air speed, humidity and solar radiation in and around the car.

#### Sensor location

- The sun sensor is on the top side of the dashboard.
- The temperature sensor for the passenger compartment is behind the climate control panel.
- The outside temperature sensor is located on the door mirror.
- The humidity sensor is located in the interior rearview mirror.

#### **i** NOTE

Do not cover or block the sensors with clothing or other objects.

#### Side windows

To ensure that the air conditioning works satisfactorily, close all side windows and the roof.

#### Acceleration

The air conditioning switches off temporarily at full throttle. You may feel a temporary rise in temperature.

#### Condensation

In warm weather, condensation from the air conditioning may drip under the car. This is normal.

03



## Electronic climate control, ECC

### Control panel

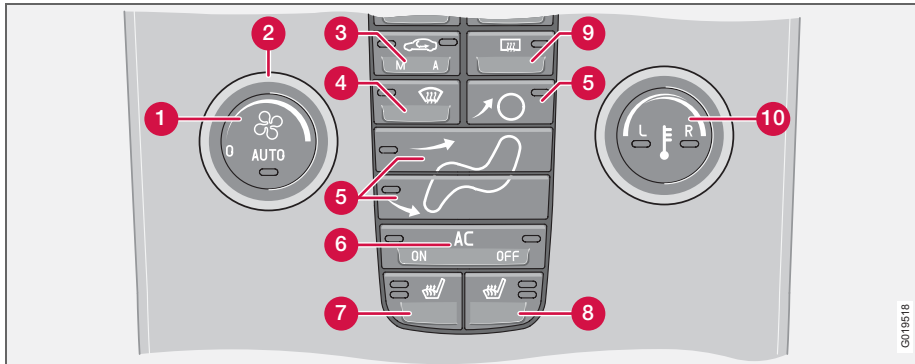

1. **AUTO**
2. Fan
3. Recirculation/Air quality system
4. Defroster
5. Air distribution
6. **AC ON/OFF** – Air conditioning On/Off
7. Heated front left seat
8. Heated front right seat
9. Rear window and door mirror defrosters
10. Temperature selector

### Functions

#### 1. AUTO

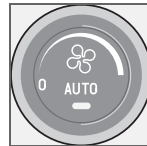

Automatically maintains a selected passenger compartment temperature by regulating heat, fan speed, recirculation and air distribution.

When the roof is open more air and heat/cold is directed down in the passenger compartment, and the output of the climate control is limited if it is not possible to compensate for the outside temperature.

When one or more manual functions are selected the other functions are controlled automatically. Pressing **AUTO** (1) switches off all manual settings. The display shows **AUTO CLIMATE**.

#### 2. Fan

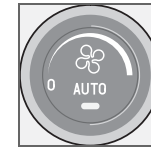

Increase or decrease fan speed by turning the knob. The fan speed is regulated automatically if **AUTO** is selected, and the previously set fan speed is disengaged.



## Electronic climate control, ECC

### **i** NOTE

If the knob is turned anticlockwise and the fan indication on the display goes out, the fan and the air conditioning are switched off. The display shows the fan symbol and **OFF**.

### 3. Recirculation

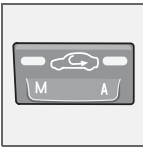

Recirculation can be used to shut out bad air, exhaust fumes, etc. from the passenger compartment. The air in the passenger compartment is recirculated, i.e. no

outside air is taken into the car when this function is activated. If the air in the car recirculates for too long, there is a risk of misting on the insides of the windows.

#### Timer

The timer function minimises the risk of icing, misting and bad air if recirculation is selected. See Personal preferences, page 61, for how to activate/deactivate the function.

### **i** NOTE

When Defroster (4) is selected, recirculation is always deactivated.

### 3. Air quality system (option)

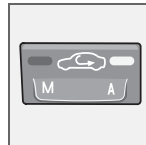

(same button as recirculation)

The air quality system consists of a multifilter and a sensor. The filter separates gases and particles to

reduce the levels of odours and pollution in the passenger compartment. When the sensor detects polluted outside air, the air intakes are closed and the air in the passenger compartment is recirculated. A green light **(A)** in the button illuminates when the air quality sensor is active.

Activating the air quality sensor:

- Press **AUTO** (1) to activate the air quality sensor (normal setting).

Or:

- Switch between three functions by pressing repeatedly the recirculation button.
- Air quality sensor engaged – the LED **(A)** illuminates.
- No recirculation engaged, provided it is not required for cooling in hot weather – LED not illuminated.
- Recirculation engaged – the LED **(M)** illuminates.

Keep the following in mind:

- As a rule, the air quality sensor should always be engaged.
- Recirculation is limited in cold weather to avoid misting.
- The defroster functions for the front, side and rear windows can be used to demist the windows.

### 4. Defroster



Quickly removes misting and ice from the windscreen and side windows. Air flows to the windows at high fan speed. The light in the defroster button illuminates

when the function is active.

The following also takes place when the defroster function is activated in order to provide maximum dehumidification in the passenger compartment:

- the air conditioning (AC) is automatically switched on (can be switched off with the **AC** button (5))
- recirculation is automatically disengaged.

When the defroster is switched off the climate control returns to the previous settings.



## Electronic climate control, ECC

### 5. Air distribution

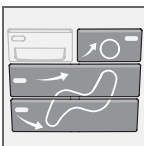

The airflow can be distributed to the windows, dashboard vents or floor by pressing the air distribution buttons.

A symbol on the display above the climate control panel and an illuminated light in the relevant button indicate which function has been selected.

See the table on p. 71.

### 6. AC – ON/OFF

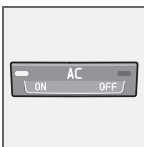

**ON:** Air conditioning is on. It is controlled by the system's AUTO function. This way, incoming air is cooled and dehumidified.

**OFF:** Off.

When the defroster function is activated the air conditioning is automatically switched on (can be switched off with the **AC** button).

### NOTE

The climate control system's demisting function with humidity sensor is significantly reduced with the air conditioning in deactivated mode (**OFF**), as well as with manually selected air distribution and fan speed.

### 7. and 8. Heated front seats

(option in certain markets)



To activate front seat heating:

- Higher heat: Press the button once – both lights illuminate.
- Lower heat: Press the button twice – one light illuminates.
- Heat off: Press the button three times – light not illuminated.

### 9. Rear window and door mirror defrosters



Use the defroster to quickly remove misting and ice from the rear window and door mirrors. The rear window and door mirrors are defrosted simultaneously if

the button is pressed once. The function is active if one lamp is illuminated in the button.

The function is switched off manually or automatically. Switch off manually with one press on the button. Automatic switching off disconnects the rear window and door mir-

rors after 12-20 minutes depending on outside temperature.

During cold weather the defrosting also continues after 20 minutes in order to keep the rear window and door mirrors free of ice and mist.<sup>1</sup> The intensity of the defrosting can be adapted to the outside temperature. This function must be switched off manually.

### 10. Temperature selector

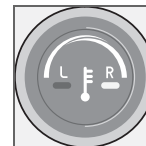

The temperatures on the driver and passenger sides can be set independently.

Press the button once to activate one side. Press again to activate the other

side. Press the button a third time to activate both sides.

The active side is indicated by the button's light and in the display above the climate control panel.

When the car is started, the most recent setting is resumed.







### NOTE

Heating or cooling cannot be hastened by selecting a higher or lower temperature than the actual desired temperature.

<sup>1</sup> Depending on market and/or options

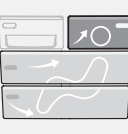

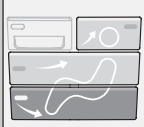
## Air distribution

Air distribution	Use:	Air distribution	Use:
	<p>Air to windows. Some air flows to the dashboard air vents. The air is not recirculated. Air conditioning is always engaged.</p>		<p>Air to the floor and windows. Some air flows to the dashboard air vents.</p> <p>To ensure comfortable conditions and good demisting in cold or humid weather.</p>
	<p>Air to windscreen and side windows. Some air flows to the dashboard air vents.</p>		<p>Air to floor and from dashboard air vents.</p> <p>In sunny weather with cool outside temperatures.</p>
	<p>Airflow to windows and from dashboard air vents.</p>		<p>Air to the floor. Some air flows to the dashboard air vents and windows.</p> <p>To warm the feet.</p>
	<p>Airflow to the head and chest from the dashboard air vents.</p>		<p>Airflow to windows, from dashboard air vents and to the floor.</p> <p>To provide cooler air for the feet or warmer air to the upper body in cold weather or hot, dry weather.</p>

03



## Fuel-driven heater (option)

### General information about heaters

The parking heater can be started immediately or set with two different start times using **TIMER AM** and **TIMER PM**. Here, start time refers to the time the car is heated and ready. The car's electronic system calculates when heating should be started based on the outside temperature. The heater is not run if the outside temperature exceeds 25 °C. At minus 10 °C and below, the maximum running time of the parking heater is 60 minutes.

### Parking on a hill

If the car is parked on a steep hill, the front of the car should point downhill to ensure that there is a supply of fuel to the parking heater.

#### WARNING

The car must be outdoors when the petrol or diesel heater is used.

#### WARNING

Switch off the fuel-driven heater before refuelling. Spilled fuel could be ignited.

Check on the information display that the heater is off. When the additional heater is running, **PARK HEAT ON** is shown on the information display.

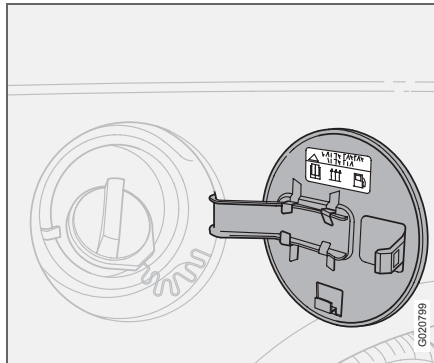

Warning decal on fuel filler flap

### Activating the heater

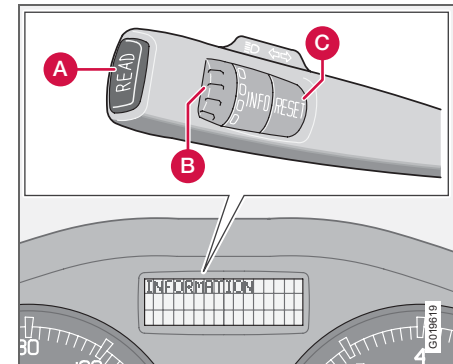

- Enter the time when the car is to be used. Press **RESET** (C) to enter the hours and minutes.
- Press and hold the **RESET** (C) button until the timer is activated.

#### Direct start

- Use the thumbwheel (B) to scroll to **DIRECT START**.
- Press **RESET** (C) to access the options **ON** and **OFF**.
- Select **ON**. The heater will now run for 60 minutes. Heating of the passenger compartment will begin as soon as the engine coolant has reached a temperature of 30 °C.

**Fuel-driven heater (option)****Immediate stop of heater**

- Use the thumbwheel (B) to scroll to **DIRECT START**.
- Press **RESET** (C) to access the options **ON** and **OFF**.
- Select **OFF**.

**NOTE**

The car can be started and driven while the parking heater is still running.

**Battery and fuel**

If the battery has insufficient charge or the fuel level is too low, the parking heater will be switched off automatically. A message appears on the information display. Acknowledge the message by pressing **READ** once (A).

**IMPORTANT**

Repeated use of the parking heater combined with short journeys may discharge the battery and impair starting. If the heater is used regularly, the car must be driven for the same time as the heater is run to ensure that the alternator has time to charge the battery.

**Setting the TIMER AM and PM**

For safety reasons, you can only programme times for the following 24 hours, not several days in advance.

- Scroll with the thumbwheel to **TIMER**.
- Touch **RESET** to move to the flashing hours setting.
- Scroll with the thumbwheel to the desired hour.
- Touch **RESET** to move to the flashing minutes setting.
- Scroll with the thumbwheel to the desired minute.
- Touch **RESET** to confirm the setting.
- Press **RESET** to activate the timer. After setting **TIMER AM**, a second start time can be programmed with **TIMER PM**. Access this with the thumbwheel. Set the alternative start time in the same way as **TIMER AM**.

**Messages on the display**

When **TIMER AM**, **TIMER PM** and **DIRECT START** are activated, the information symbol on the combined instrument panel illuminates and an explanatory text appears on the information display. The display also indicates which **TIMER** is active when the driver removes the key from the ignition to leave the car.

**Clock/timer**

If the car clock is reset after the heater timers are programmed, the selected times will be cancelled.

**Additional heater (diesel)**

(certain countries)

Extra heat from the additional heater may be required in cold weather to reach the correct temperature in the passenger compartment.

The additional heater starts automatically when extra heat is required if the engine is running. It is switched off automatically when the correct temperature is reached or when the engine is switched off.

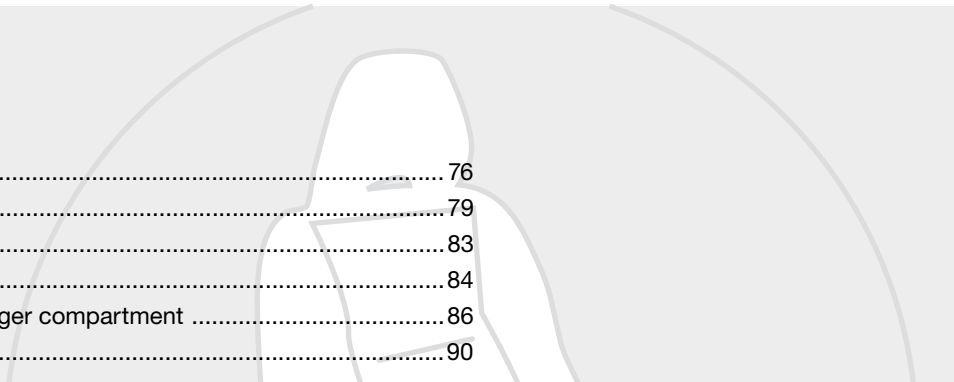

Front seats .....	76
Electrically operated roof .....	79
Wind deflector (option) .....	83
Interior lighting .....	84
Storage spaces in the passenger compartment .....	86
Cargo area .....	90

INTERIOR



04



## Front seats

### Seating position



The driver's and passenger seats can be adjusted to the optimum sitting and driving positions

1. Forward/backward: lift the handle to adjust the distance to the steering wheel and pedals. Check that the seat is locked after changing position.
2. Raise/lower front edge of seat cushion, pump up/down.
3. Raise/lower the seat, pump up/down.
4. Lumbar support<sup>1</sup>, turn the wheel.
5. Adjust backrest rake, turn the wheel.
6. Control panel for power seat (option).

<sup>1</sup> Also applies to power seat.

The control (2) is not available for all seat models.



### WARNING

Adjust the position of the driver's seat before setting off, see page 13, never while driving.

Check that the seat is locked in position.

### Entry to the rear seat – Easy entry

Make sure that the seatbelt is removed from the belt guide before passengers enter or exit the car, see page 14. The easy entry position is intended for use when the seat is empty.

### Mechanical seat

Move the seat forward:

- Move the handle (1) up to release the backrest.
- Fold the backrest forward until it locks.
- Release the handle and slide the seat forwards.

Move the seat backward:

- Move the seat backward to the original position.
- Move the handle (1) up to fold the backrest back.

The seat returns to the same position it had before folding forward for Easy entry.

### Power seat

Move the seat forward:

- Move the handle (1) up to release the backrest.
- Fold the backrest forward until it locks.
- Press the button (2) located by the side of the head restraint. Keep it pressed in.

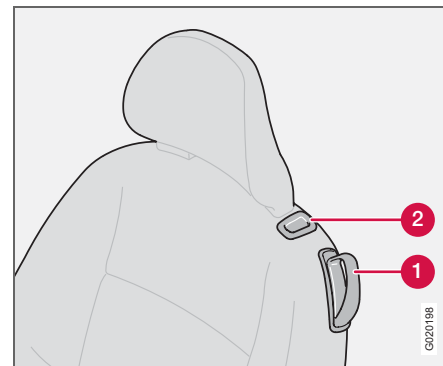

*Easy entry*

Move the seat backward:

- Press the button (2) located to the side of the head restraint. Keep it pressed in.
- Move the handle (1) up and fold back the backrest.



## Front seats

**i NOTE**

The seat can only be moved to the very front (+6 cm) to facilitate entry and exit to and from the rear seat when the backrest has been folded forward.  
If the backrest is folded back when the seat is in the front position then the seat automatically moves back approx. 6 cm after a few seconds.

**! WARNING**

Check that the backrest is properly folded back by pushing and pulling the head restraint.

The belt on the front passenger side must be in the belt guide during driving, even when there is no passenger sitting in the seat.

**Floor mats (option)**

Volvo supplies floor carpets which are especially produced for your car.

**! WARNING**

The floor mat at the driver's seat must be firmly fitted and secured in the attachment clips to prevent it from being trapped around and under the pedals.

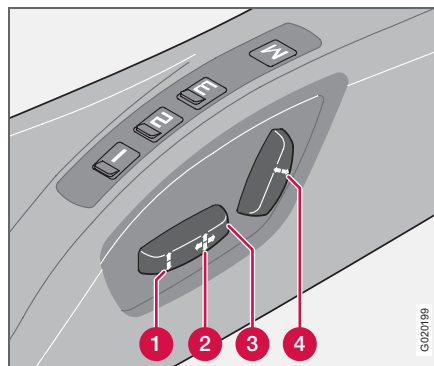
**Power seat (option)**

The seats can be adjusted for a certain time after unlocking the door with the remote control without the key being inserted into the ignition switch. The seat can always be set in ignition position **I** or **II**.

1. Front edge of seat cushion up/down
2. Seat, forwards/backwards
3. Seat, up/down
4. Backrest rake

Overload protection is deployed if any seat is blocked. If this occurs, switch off the ignition and wait a short time before operating the seat again. Only one of the seat's settings can be adjusted at a time.

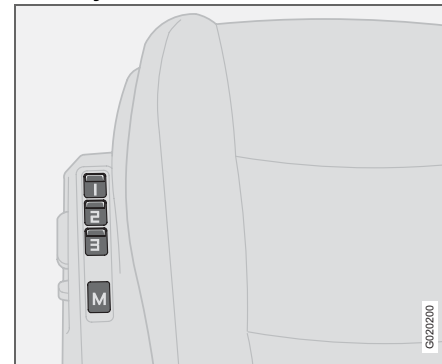
**Memory function**

Buttons for memory function

**Store setting**

- Adjust the seat and the door mirrors.
- Press and hold button **M** while pressing button **1**, **2** or **3** simultaneously.

**Using a stored setting**

Press one of the memory buttons **1** – **3** until the seat and the door mirrors stop. If you release the button then the movement of the seat will stop.

**Key memory in remote control key**

The positions of the driver's seat and the door mirrors are stored in the key memory



### Front seats

when the car has been locked with the remote control key. When the car is unlocked with the same remote control key the driver's seat and the door mirrors adopt the stored positions when the driver's door is opened.



#### NOTE

The key memory is independent of the seat memory.

#### Emergency stop

If the seat accidentally begins to move, press any of the buttons to stop the function.



#### WARNING

Risk of crushing. Make sure that children do not play with the controls.

Check that there are no objects in front of, behind or under the seat during adjustment. Ensure that none of the rear seat passengers is in danger of becoming trapped.



## Electrically operated roof

### Conditions for roof operation

- No objects on the parcel shelf.
- No ice, snow or loose objects on the roof or boot lid.
- Dry roof.
- 2.0 m clearance upward (A) and 0.2 m between bumper and objects behind (B).
- Ambient temperature  $-10^{\circ}\text{C}$  or warmer.
- Closed cargo separator, see page 90.
- Closed boot lid.
- Stationary car, brake pedal depressed.

If the instructions on the following pages are not followed then this could cause damage to the roof's opening and closing mechanisms.

Volvo also recommends that the following is observed:

- Level ground.
- Execution of roof operation in one single movement.
- Engine at idling speed.

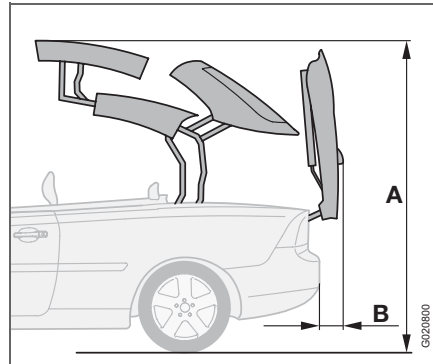

### IMPORTANT

Water collecting on the roof can run down into the cargo area and the passenger compartment if the roof is opened.



### WARNING

People, children or objects can be trapped by the roof or boot lid's moving parts.

- Operate the roof with caution.
- See decal on the cargo separator.
- Do not allow children to play with the controls.
- Do not leave the roof in a stationary position for longer than necessary.



### WARNING

Never leave the car key in the car if there are children in the car.





## Electrically operated roof

### Hatch cover

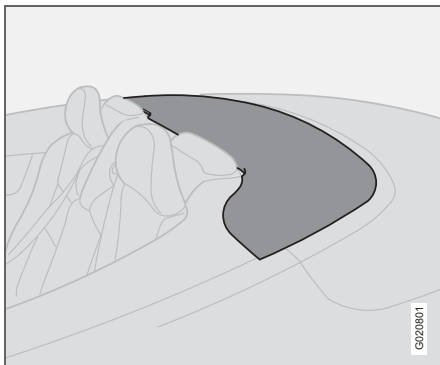

When the roof is open there is a hatch cover between the head restraints in the rear seat and the boot lid, see illustration.

### **!** IMPORTANT

Do not sit on the hatch cover or use it as a support as it could be damaged.

### Opening and closing the roof

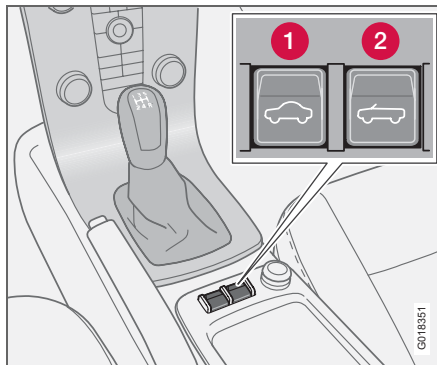

- Turn the ignition key to position **II**, preferably starting the engine.
- Depress the brake pedal.
- Keep the left-hand button (1) pressed in to close, or the right-hand button (2) to open.

Pay attention to any messages on the information display while the roof is in motion. The windows that are closed are opened approx. 10 centimetres. All windows are closed when the movement of the roof is completed.

Release the button when a signal sounds and the message **ROOF CLOSED** or **ROOF OPEN** is shown on the information display.

### **!** WARNING

Never pull the release wire for the hydraulic system that is located under the rear seat cushion. Only service personnel are allowed to use the hydraulic system's emergency release function.

Consequences:

- significant risk of crushing injury
- uncontrolled movement/opening of the electrically operated roof or boot lid
- the roof components could be destroyed.

Make thoroughly sure that the conditions are fulfilled before operating the roof.

### Text on the information display

A number of these messages also apply to loading assistance, see page 91.

- **PRESS BRAKE FOR ROOF OPERATION**  
Depress the brake pedal in order to operate the roof.
- **OPEN BOOT LID FULLY**  
– Open boot lid fully.
- **CLOSE BOOT FOR ROOF OPERATION**  
– The boot lid is not closed. Close the boot lid.
- **CLOSE BOOT SEP. FOR ROOF OPERAT.**  
– The cargo separator is not closed. Close the cargo separator, see page 90.



## Electrically operated roof

- **LOW BATTERY FOR ROOF OPERATION** – The battery voltage is too low. The roof can only be closed. Charge the battery, e.g. by starting the engine, and try again.
- **ROOF NOT LOCKED** – The roof has not been opened or closed properly. Try again to open or close the roof.
- **ROOF IN LOAD AID POSITION** – The roof has been raised with the loading assistance function. Lower the roof, see page 90.
- **TEMP LIMITS ROOF OPERATION** – The roof system is either overheated or the outside temperature is below  $-10\text{ }^{\circ}\text{C}$ . If the roof is overheated, wait approx. five minutes until the message goes and try again.

### Messages with roof faults

Two messages can be shown on the information display in the event of a roof fault:

- **ROOF FAILURE SERVICE REQUIRED** – The roof cannot be operated. This requires service by an authorised Volvo workshop. Covering over can be performed in accordance with the instructions.
- **ROOF FAILURE SEE MANUAL** – The roof or loading assistance must be operated in accordance with special instructions. Service must be performed by an authorised Volvo workshop.

### Special instructions for manoeuvring in the event of a roof fault

If the message **ROOF FAILURE SEE MANUAL** is shown on the information display then the roof cannot be operated normally.

#### NOTE

After the roof has been closed it cannot be opened again.

#### IMPORTANT

Closing in the event of a roof fault requires very careful checking of the conditions for operating the roof, see page 79. Even if the conditions are fulfilled, there is a significant risk of material damage.

- Keep the closing button pressed in until **ROOF FAILURE SEE MANUAL** is shown on the display. Following which, release the button.
- Press the closing button again. Keep it pressed in for at least 30 seconds until the roof and boot lid are closed. Pay attention for any faults that could cause damage to the car.

A signal sounds during the whole closing operation.

#### WARNING

Never pull the release wire for the hydraulic system that is located under the rear seat cushion. Only service personnel are allowed to use the hydraulic system's emergency release function.

Consequences:

- significant risk of crushing injury
- uncontrolled movement/opening of the electrically operated roof or boot lid
- the roof components could be destroyed.

Repairs must only be performed by an authorised Volvo workshop. Any interference in the roof system could cause malfunction and serious injury as a result.



## Electrically operated roof

### Plastic cover for temporary covering

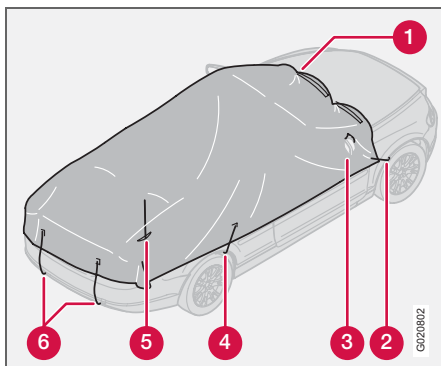

If the roof cannot be closed due to low battery voltage or a possible roof fault then a protective plastic cover can be fitted. The plastic cover is fitted with the rope attachments inward.

The plastic cover is stored in a bag marked "Cover for temporary use".

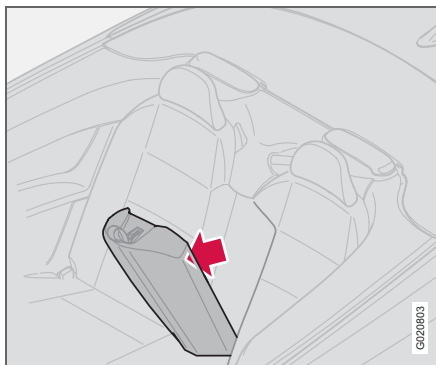

Plastic cover, located in the ski hatch.

- Raise the windows (if possible).
- Take the plastic cover from the centre panel in the rear seat backrest at the ski hatch.
- Take the plastic cover from the package and unwrap it.
- Thread the hole (3) over the door mirror and secure the hooks (2) in the front wheel arches.
- Clamp the plastic cover between the wiper blades and the windscreen and stretch the plastic so that it has one tuck (1) per wiper blade.
- Guide through the antenna (5).
- Secure the hooks (4) in the rear wheel arches and the hooks (6) under the rear bumper.



## Wind deflector (option)

### Wind deflector

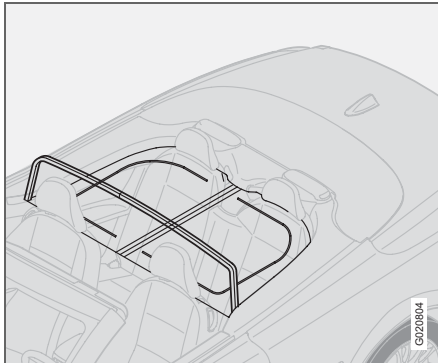

Wind deflector

The wind deflector can be used when driving with a lowered roof to reduce the swirling airflow and draughts in the passenger compartment.

#### Installing the wind deflector

- Fold out the four-part deflector to its full size and press the catch together.
- Insert the wind deflector's supports under the head restraints so that they are resting against the top edge of the backrest.

#### **i** NOTE

Be careful of the car's upholstery.

- Press the locking levers into the holders on the side panels until a click is heard.
- Open out the wind deflector.

The zips in the wind deflector are used for storing/retrieving luggage on the rear seat.

#### **!** WARNING

Check that the wind deflector is secured firmly. Otherwise it may detach in the event of sudden movement for example and then cause injury and damage.

#### **!** WARNING

No passengers are allowed in the rear seat when the wind deflector is fitted.

The deflector is stored in the cargo area in its bag, under the cargo separator, furthest forward against the backrest.



## Interior lighting

### Front seat lighting

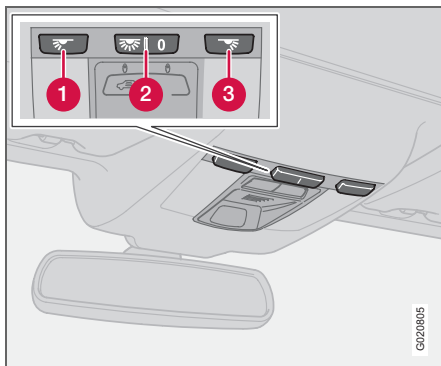

1. Reading lamp left-hand, On/Off
  2. Passenger compartment lighting front and rear
  3. Reading lamp right-hand, On/Off
- Switch (2) has three positions for the interior lighting:

- Off (0) – right-hand side depressed, automatic lighting off.
- Neutral position – interior lighting comes on when a door is opened and goes out when the door is closed. The dimmer function is active.
- On – left-hand side depressed, passenger compartment lighting on.

The reading lamps can be switched on in ignition position I and II as well as when the engine is running. They can also be activated within 30 minutes after the engine has been switched off or when one of the doors has been opened/closed.

### Rear seat lighting

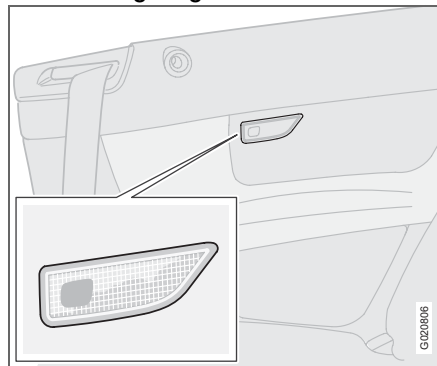

Switched on or off with one press of the button.

### Automatic lighting

The passenger compartment lighting is switched on and off automatically when button (2) is in neutral position.

The passenger compartment lighting is switched on and remains on for 30 seconds if:

- the car is unlocked from the outside with the key or remote control
- the engine is stopped and the ignition key is turned to position 0

The passenger compartment lighting is switched off when:

- the engine is started
- the car is locked from the outside with the key or remote control

The passenger compartment lighting comes on and remains on for 5 minutes if one of the doors is open.

The passenger compartment lighting can be switched on or off within 30 minutes from the time that the key is turned to position 0, using button (2). The lighting remains on for 5 minutes if it is not switched off.



### Vanity mirror<sup>1</sup>

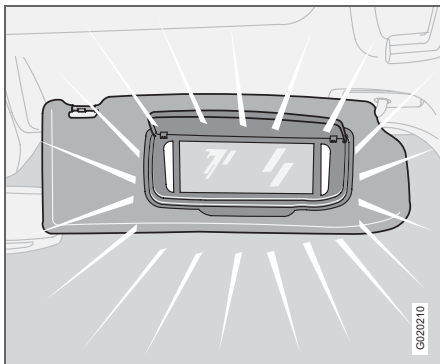

The light illuminates automatically when the cover is lifted.

<sup>1</sup> Option on certain markets



## Storage spaces in the passenger compartment

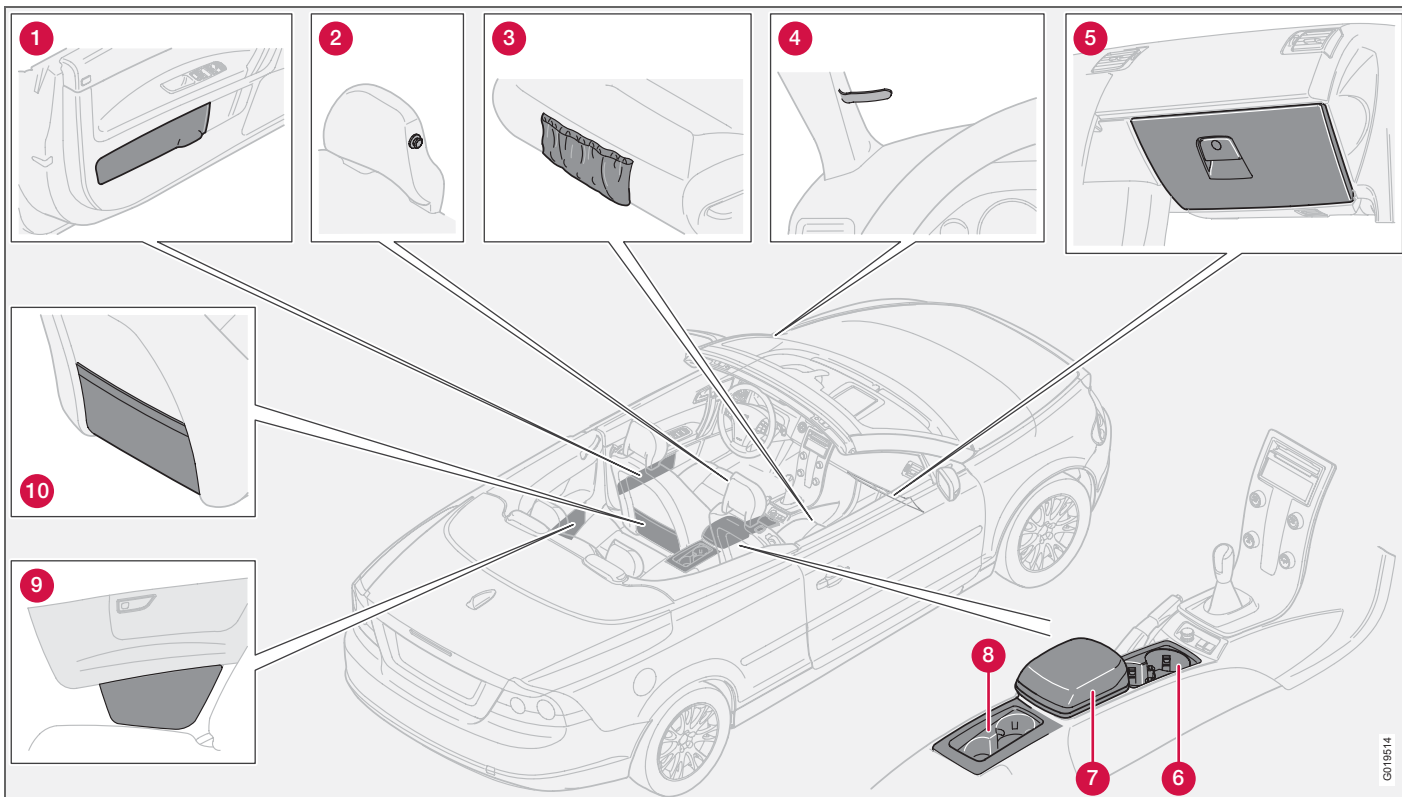

G018514



## Storage spaces in the passenger compartment

### Storage spaces

1. Storage compartment in door panel with holder for ice scraper (lockable as option).
2. Coat hanger, only for light garments.
3. Storage pocket on front edge of front seat cushions.
4. Ticket clip
5. Glovebox
6. Cup holder (with roller cover, option certain markets)
7. Tunnel compartment (e.g. for CD discs)
8. Cup holder (with roller cover, option)
9. Storage compartment in rear side panel.
10. Storage pocket on the rear edge of the front seats.



### WARNING

Ensure that no hard, sharp or heavy objects lie or protrude in such a way that they could cause injury during heavy braking.

Always secure large and heavy objects with a seatbelt or cargo retaining straps.

### Glovebox

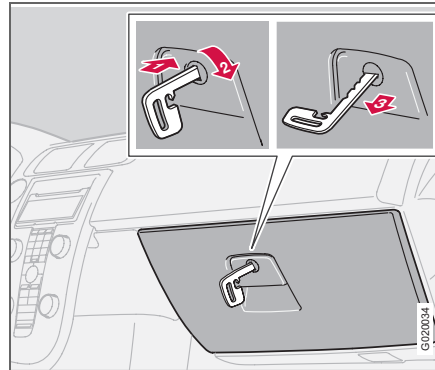

The owner's manual and maps can be kept here. There are also holders for coins, pens and fuel cards. The glovebox can be locked with the remote control's detachable key blade. Further information is available on page 98.

Locking the glovebox:

1. Insert the key blade into the keyhole.
2. Turn the key a quarter of a turn (90 degrees) clockwise.
3. Remove the key. The keyhole is horizontal in the locked position.

To unlock the glovebox, carry out the above in reverse order.

### Coat hanger

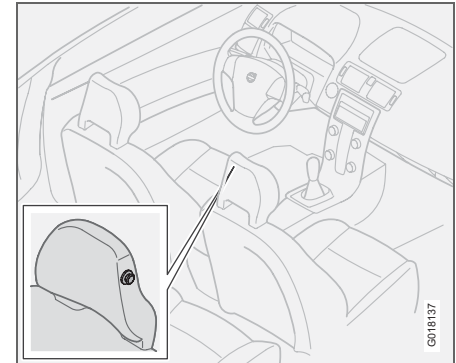

The coat hanger is located on the passenger seat head restraint. Only hang light garments on the hanger.





## Storage spaces in the passenger compartment

### Storage compartment in rear side panel

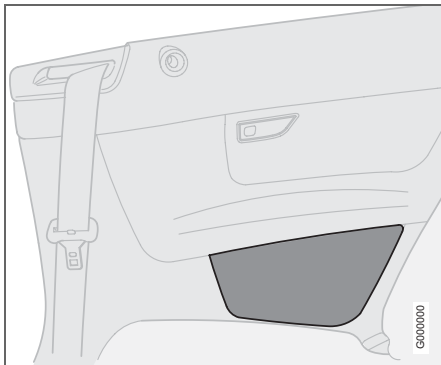

The storage compartment is opened and closed with a touch in the centre of its upper section.

### Storage under the front armrest

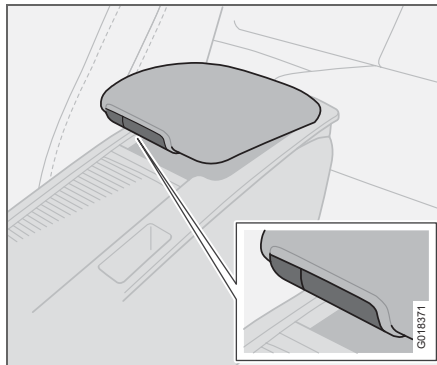

There is a storage space under the armrest. There is also a smaller storage space in the detachable armrest. Press the small button and lift the armrest to open the shallow compartment. Press the large button and lift the armrest to open the deeper compartment.

### Cup holder in centre console

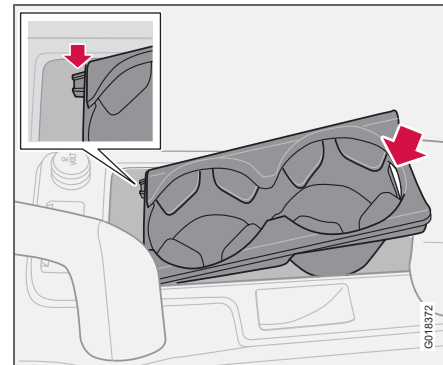

There is space for a double cup holder under the roller cover. The space can be used for storage by lifting out the cup holder. Lift at the rear edge of the cup holder where there is a recess.

If the cup holder is being fitted - first align its two guide lugs in the two recesses in the front edge of the space and then press down the rear edge of the cup holder.

Close the roller cover by gripping its front edge from below and pulling forward.



## Storage spaces in the passenger compartment

### Storage compartment behind the handbrake

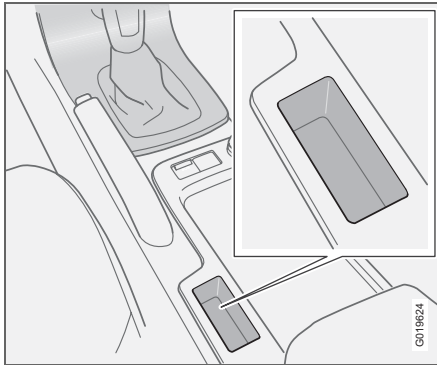

When there are no buttons for parking assistance and BLIS, see page 133 and page 136, the space can be used as a storage compartment.



## Cargo area

### Cargo separator

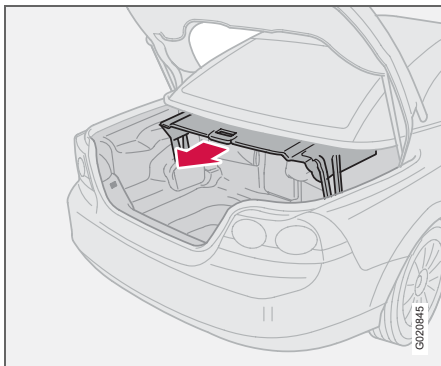

The purpose of the separator is to limit the amount of the load in the cargo area so that the movement of the roof is not disrupted. Be sure to close the cargo separator fully so that it is locked on both the left and right-hand sides.

#### **!** IMPORTANT

Do not place objects above or alongside the cargo separator when it is closed. Do not position luggage so that it is higher than the closed cargo separator.

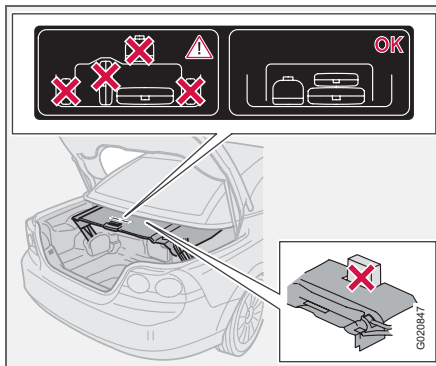

Decal on cargo separator

#### **i** NOTE

Too much load in the cargo area prevents the cargo separator from being closed. Consequently the roof is also prevented from opening.

### Loading assistance

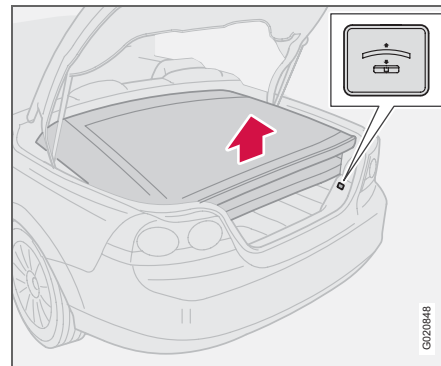

Button for raising and lowering the roof.

In open position the roof is folded up in the cargo area. The roof can be raised or lowered to facilitate loading and unloading using the button (see illustration). The movements for loading assistance constitute a small amount of the normal movement of the roof. Consequently the messages for roof operation on the information display also apply to loading assistance, see page 80.

#### **!** WARNING

People or objects which prevent the raising and lowering of the roof are at risk of being trapped.



### Using loading assistance

One press on the button both starts and stops raising/lowering. It may take several seconds before the movement starts. If a signal sounds when the button is pressed and the roof does not move, read the message on the information display.

- Press the button to raise the roof.
- Lift the cargo separator and move it into the cargo area.
- When loading is complete, fold down the cargo separator.
- Press the button so that the roof is lowered.



#### NOTE

If the battery level is too low then the roof can only be lowered.

### Using loading assistance with roof faults

If the message **ROOF FAILURE SEE MANUAL** is shown on the information display then the roof can only be lowered.

- Check that **ROOF FAILURE SEE MANUAL** is shown on the display.
- Keep the button depressed for approx. 5 seconds. Keep the button depressed while the roof is lowered.

A signal sounds during the whole lowering operation.



#### IMPORTANT

When the roof is raised for loading assistance or if the movement is interrupted by pressing in the button twice then the boot lid must not be closed. This could result in damage and malfunction in the system.



## Cargo area

### Load retaining eyelets

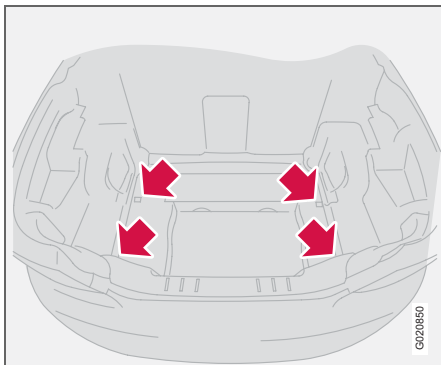

There are four or more eyelets for securing straps or ropes. Straps that are suitable for the eyelets are supplied by Volvo dealers.

### Electrical socket in cargo area

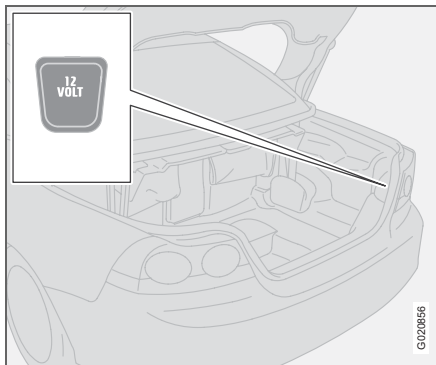

Fold down the cover to access the electrical socket which socket works regardless of whether or not the ignition is on.

Remember to avoid using the electrical socket with the ignition switched off due to the risk of discharging the battery.

### Ski hatch

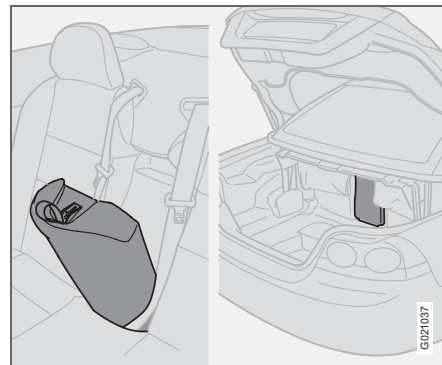

There is a hatch behind the centre panel<sup>1</sup> in the rear seat backrest for transporting long, light objects.

Max. length: 2 m and max. weight: 25 kg. The ski hatch is opened from two directions, from the centre panel and from inside the cargo area.

<sup>1</sup> Emergency puncture repair kit, first aid, plastic cover and towing eye are stored in the centre panel in the rear seat backrest. For cars with spare wheel (option), see page 161.



### Open the centre section in the back of the rear seat

- Pull the strap in the top of the backrest centre section to access the hatch.

### Close the centre section in the back of the rear seat

- Refit the centre section with the lower part first.
- Fold in the centre section and press until a clicking sound is heard.

### Hatch in cargo area

If the car is equipped with ski bag<sup>1</sup> then the zip in the bag must also be opened from the passenger compartment.

- Press the buttons in the two holes in the hatch towards each other and open the hatch.

### Locking the ski hatch

Locked with the remote control, see page 99.

### Secure long loads with the seatbelt

Long loads, for example skis, must be secured with the rear seat's seatbelt.

- Wrap the seatbelt one turn around the skis and lock it in the normal way in the seatbelt buckle.

<sup>1</sup> Option

If the car is equipped with a ski bag<sup>1</sup> then the belt must be threaded through its handle.



### WARNING

Stop the engine and apply the parking brake when loading or unloading long objects.

A loose object weighing 20 kg can, in a frontal collision at a speed of 50 km/h, carry the impact of an item weighing 1000 kg.

Always secure the load. During heavy braking the load may otherwise shift, causing personal injury.

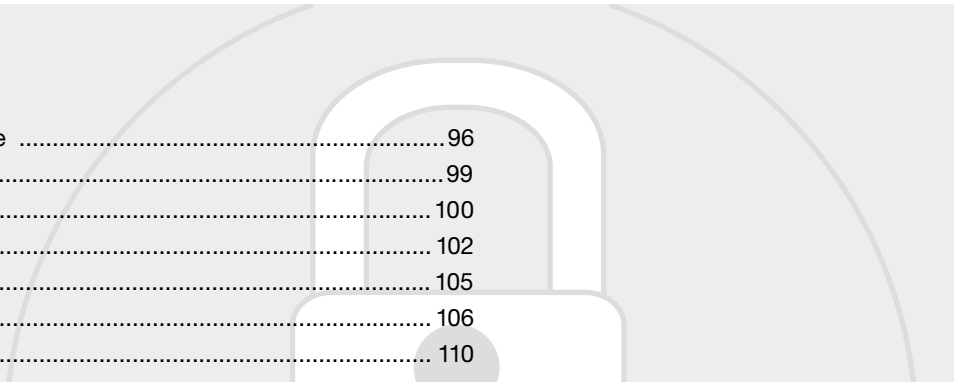

Remote control with key blade .....	96
Active locks .....	99
Privacy locking (option) .....	100
Keyless drive (option) .....	102
Battery in remote control .....	105
Locking and unlocking .....	106
Alarm (option) .....	110

## LOCKS AND ALARM



# 05





### Remote control with key blade

#### Remote control

The car is supplied with two remote controls. They also serve as ignition keys. The remote controls contain detachable metal key blades for mechanical locking/unlocking of the driver's door, boot lid and glovebox.

The key blades' unique code is available at authorised Volvo workshops, who can order new key blades.

A maximum of six remote controls/key blades can be programmed and used for one single car.

#### Turn signal indication during locking/unlocking

When the car is unlocked using the Keyless Drive system or the remote control, two short flashes of the direction indicators serve to indicate that unlocking was correctly performed.

For locking, the indication takes place with one long flash and only if all locks have been locked, after the doors and the boot lid have been closed.

Personal preferences can be used to deactivate indication via the direction indicators. There will then be no visual indication as to whether the lock status is correct. See page 62.

#### Loss of a remote control

If you lose a remote control, take the car and the other remote controls to an authorised Volvo workshop. The code of the missing remote control must be erased from the system as a theft prevention measure.

#### Immobiliser

The remote controls are fitted with coded chips. The code must be accepted by the reader (receiver) in the ignition switch. The car can only be started if the correct remote control with the correct code is used.



## Remote control with key blade

### Remote control functions

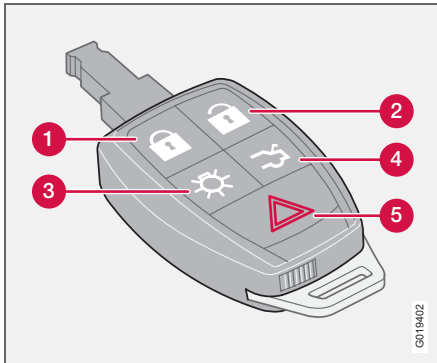

1. Locking – locks the doors, the boot lid, the storage compartments in the door panels (lockable as option) as well as the ski hatch. The remote control does not lock the glovebox.
2. Unlocking – unlocks the doors, the boot lid, the storage compartments in the door panels (lockable as option) as well as the ski hatch. The remote control does not unlock the glovebox. Press and hold to open the side windows.
3. Approach lighting – used to switch on the car's lighting at a distance, e.g. if a driver is approaching a locked car and wants it illuminated. Press the yellow button on the remote

control to switch on the interior lighting, position/parking lamps, number plate lighting and door mirror lamps (option). The lighting is switched off automatically after 30, 60 or 90 seconds. For time setting, see page 62.

4. Boot lid – Press the button once to unlock the boot lid only.



#### NOTE

The function does not open the boot lid.

5. Panic function – Used to attract attention in an emergency. Press and hold the red button for at least three seconds or press it twice within three seconds to activate the direction indicators and the horn. The function can be turned off with the same button once it has been active for at least 5 seconds. Otherwise the function switches off automatically after 30 seconds.



#### IMPORTANT

The narrow section of the remote control is particularly sensitive - this contains the chip. The car cannot be started if the chip is damaged.



## Remote control with key blade

### Detachable key blade

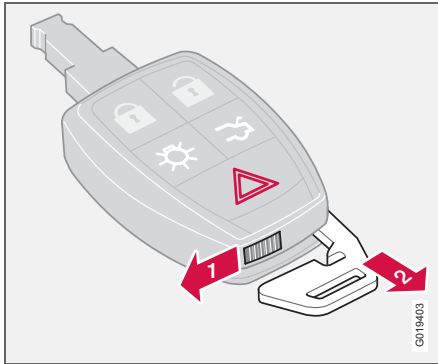

Using the remote control's detachable key blade:

- the driver's door can be opened manually if central locking is not activated with the remote control, see the section and page 103.
- the boot lid can be opened manually if central locking is not activated with the remote control, see page 107.
- access to the glovebox and cargo area (privacy locking) is blocked, see page 100.

### Removing the key blade

To take the key blade out of the remote control:

- Slide the spring-loaded catch (1) to the side while pulling the key blade (2) out.

### Inserting the key blade

Be careful when inserting the key blade into the remote control.

- Hold the remote control with the narrow end pointing down and lower the key blade into its slot.
- Lightly press the key blade to lock it in position. You should hear a "click".

### Unlocking doors with the key blade

If central locking cannot be activated with the remote control, e.g. if the batteries are discharged, then the driver's door can be unlocked and opened as follows:

- Insert the key blade in the driver's door keyhole.
- Turn the blade 45 degrees clockwise and open the door.



### NOTE

When the driver's door is unlocked using the key blade and is opened, the alarm is triggered. It is deactivated by inserting the remote control in the ignition switch. See page 111.

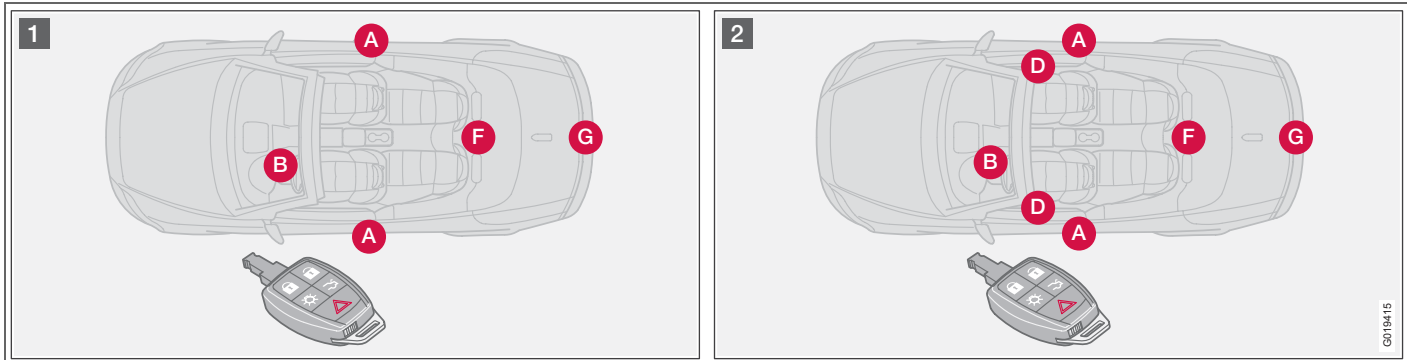

## Active locks

**1. Active locks for remote control:**

- A. Doors
- B. Steering lock
- F. Ski hatch
- G. Boot lid

**2. Active locks for remote control with lockable storage compartments:**

- A. Doors
- B. Steering lock
- D. Storage compartments in door panels
- F. Ski hatch
- G. Boot lid

For descriptions of the different storage areas, see page 87.



## Privacy locking (option)

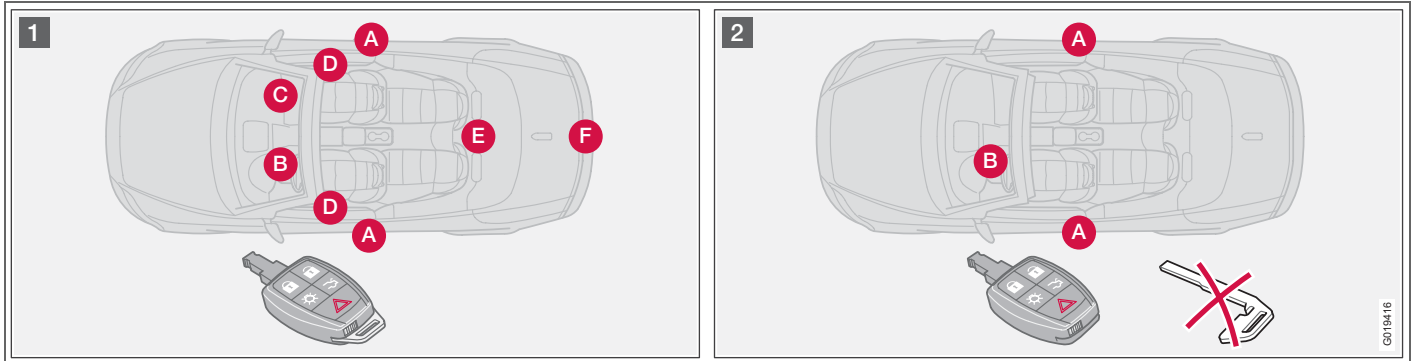

1. Central locking's normal active locks with the remote control. 2. Active locks for remote control with key blade removed and with activated privacy locking.

The privacy locking function<sup>1</sup> means that the remote control's normal control of central locking is limited; the car's lockable storage compartments are blocked and cannot be unlocked with the remote control. This can be desirable when the car is left for service, at a hotel or similar.

With the privacy locking function activated the remote control can only be used to arm/disarm the alarm, lock and unlock the doors (A) as well as to start and drive the car (B).

<sup>1</sup> Certain markets.

### Activating privacy locking

#### NOTE

When opening/closing the folding roof there is the option to temporarily access the contents in the cargo area.

- The folding roof must be closed.
- Open the boot lid and fold up the cargo separator; at which operation of the folding roof is blocked, see page 90.

#### NOTE

The information display will show **CLOSE BOOT SEP. FOR ROOF OPERAT.**

- Close the boot lid.
- Remove the detachable key blade from the remote control, see page 98.



## Privacy locking (option)

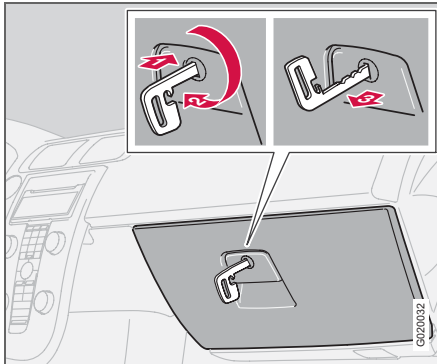

- Insert the key blade into the glovebox keyhole (C) and turn 180 degrees clockwise. The keyhole is vertical in the locked position for privacy locking.

### NOTE

Do not reinsert the key blade into the remote control but keep it in a safe place instead.

Following which, the glovebox is locked and the lockable storage compartments behind the door panels (D), the ski hatch (E) and the boot lid (F) can no longer be unlocked with the remote control.

### Deactivating privacy locking

In order to reconnect the lockable storage compartments to the central locking's automatic system, proceed as follows:

- Insert the remote control's detachable key blade into the glovebox keyhole (C) and turn 180 degrees anticlockwise.
- Replace the key blade in the remote control, see page 98.

Following which, the glovebox is unlocked and all central locking functions are controlled by the remote control again.

### Locking the glovebox only

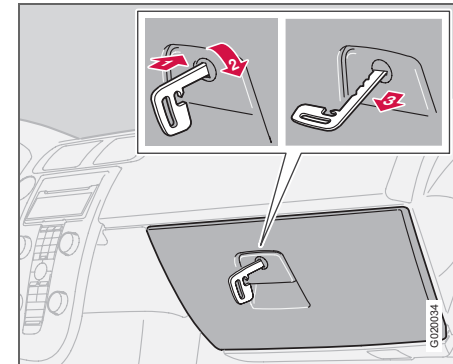

The glovebox can only be locked/unlocked using the remote control's detachable key blade. For information on removing the key blade, see page 98.

- Lock the glovebox by turning the key blade a quarter of a turn (90 degrees) clockwise. The keyhole is horizontal in the locked position.
- Unlock by carrying this out in reverse order. The keyhole is vertical in the unlocked position.



## Keyless drive (option)

### Keyless lock and ignition system

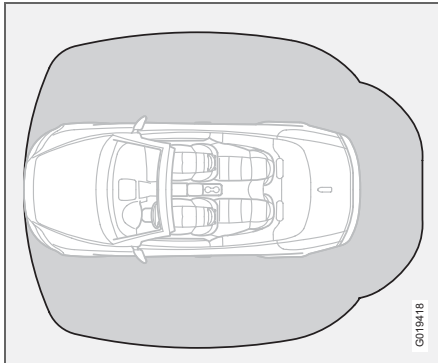

Keyless function range.

The keyless drive system allows the car to be unlocked, driven and locked without the need for a key. You simply need to have the remote control with you in a pocket or a bag.

The system makes it easier and more convenient to open the car, for example with shopping bags in one hand and a child in the other. It saves you having to take out or look for the remote control.

The two remote controls incorporate the keyless drive function. You can order additional remote controls. The keyless drive system can handle up to six remote controls.

### Remote control max. 1.5 m from the car

In order to open a door or the boot lid, a remote control must be no more than approx. 1.5 m from the car door handle or boot lid.

This means that the person who wishes to open a door must have the remote control with him or her. It is not possible to open a door if the remote control is on the other side of the car.

The grey area in the illustration indicates the range covered by the system's antennas.

If someone leaves the car and takes a keyless drive remote control with them, a warning message appears on the information display and a reminder signal sounds. The warning message disappears when the remote control is brought back to the car or when the ignition dial is turned to position 0. The warning is only issued if the ignition dial is in position I or II after someone has opened and closed a door.

The warning message and reminder signal disappear when the remote control is brought back to the car after one of the following actions:

- a door has been opened and closed
- the ignition dial has been turned to position 0
- the **READ** button has been pressed.

### Never leave any remote control in the car

If a remote control with keyless drive function is left in the car, it is made passive when the car is locked. This prevents unauthorised entry.

If someone breaks into the car and finds the remote control, it can be activated and used again. It is therefore important to handle all remote controls with care.

### Interference to remote control function

Electromagnetic screening and fields can interfere with the keyless drive system. To avoid this: do not place the remote control near mobile phones, metallic objects or, for example, in a metal briefcase.

If interference is experienced nonetheless, use the remote control and key blade in the normal way. See page 96.



## Keyless drive (option)

### Locking

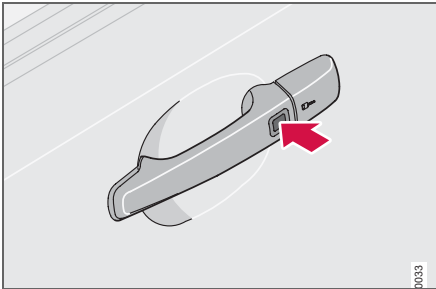

Cars with the keyless system have a button on the outside door handles.

When the remote control is within the range covered by the system's antennas, the doors and the boot lid are locked as follows:

- Push in the lock button on one of the door handles.

Both doors must be closed before the lock button is depressed. Otherwise they are not locked.

When the car is locked, the lock buttons on the inside of the doors retract.

An LED on the inside of the door in question illuminates, see page 108.

### NOTE

On cars with the keyless drive system and automatic transmission the gear selector must be moved to the **P** position and the ignition dial turned to the **0** position. Otherwise the car cannot be locked or alarmed.

### Unlocking

When the remote control is within the range covered by the system's antennas:

- Open the doors by pulling the relevant handle.
- Open the boot lid by pressing under the boot lid opening button and then lift the boot lid.

If for some reason the keyless drive function in the remote control is not operating, the car can be unlocked using the remote control functions, see page 97.

### Power seat (option) – remote control with memory function

If several people with keyless drive remote controls get into the car, then the driver's seat will be adjusted for the person who opens the door first.

### Unlocking doors with the key blade

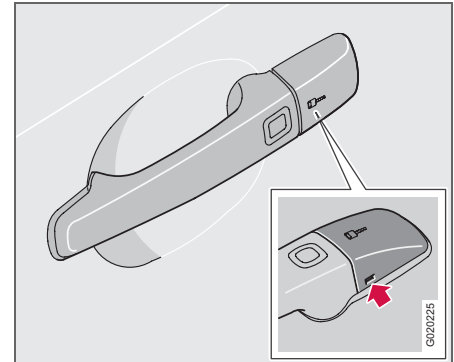

If central locking cannot be activated with the remote control, e.g. if the batteries are discharged, then the driver's door can be opened as follows:

- To access the keyhole:  
Carefully prise off the plastic cover on the handle by inserting the key blade into the hole on the underside of the plastic cover.
- Unlock the door using the key blade.

### NOTE

When the driver's door is unlocked using the key blade and is opened, the alarm is triggered. It is deactivated by inserting the remote control in the ignition switch. See page 111.





## Keyless drive (option)

### Antenna location

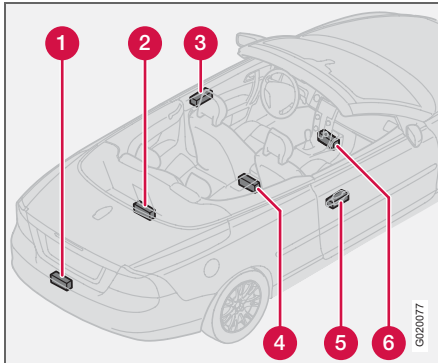

The keyless system has a number of integrated antennae located around the car:

1. Rear bumper, inside centre
2. Cargo area, central and furthest in under the floor
3. Door handle, left
4. Centre console, under the rear section
5. Door handle, right
6. Centre console, under the front section.



### WARNING

People with pacemaker operations should not come closer than 22 cm to the keyless system's antennae with their pacemaker. This is to prevent disturbances between the pacemaker and the keyless system.

### Personal preferences

The Keyless Drive system can have personal preferences applied, see page 62.

**Battery in remote control****Weak remote control battery**

When the battery runs down and full functionality cannot be guaranteed, the information symbol illuminates and the **REMOTE BATTERY LOW VOLTAGE** appears on the display.

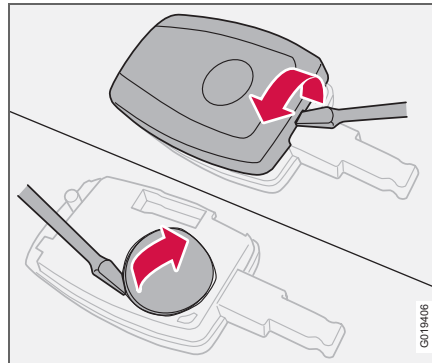
**Replacing the remote control battery**

Dispose of the old battery in an environmentally-responsible manner.

If the locks repeatedly fail to respond to signals from the remote control at a normal distance, the battery should be replaced (type CR 2450, 3 V).

- Place the remote control with the keypad downward and prise up the cover using a small screwdriver.
- Remove the cover.
- Carefully examine how the battery's + and - sides are fitted (there is a diagram under the cover).
- Prise away and replace the battery. Avoid touching the battery and its terminals with your fingers.
- Refit the cover and press it in.



## Locking and unlocking

### Locking/unlocking the car from outside

For cars with the keyless system, see page 102.

### Unlocking

The remote control unlock button can unlock the car in two different ways (select option in personal preferences, see page 62):

- with one press unlock both doors as well as the boot lid
- with one press unlock the driver's door and with a second press unlock the other door and the boot lid.

### Locking

The remote control locks the doors and the boot lid simultaneously. The door lock buttons and inside handles are disengaged<sup>1</sup>.

The fuel filler flap cannot be opened if the car is locked with the remote control.



### NOTE

The car can be locked even if a door or the boot lid is open. When the door is closed there is a risk that the keys will be locked in. (Applies to certain markets.)

<sup>1</sup> Applies to certain markets



### WARNING

Be aware that you can be locked in the car if it is locked from the outside with the remote control. You cannot leave the car using any of the controls inside the car.

### Global opening

Press and hold the unlock button to open all side windows simultaneously.

The function can be used to quickly air the car in hot weather for example.

Different personal settings can be made, see page 62.

### Boot lid

#### Unlocking

Unlocking the boot lid only:

- Press the boot lid unlock button on the remote control.

#### Locking

If the doors are locked when the boot lid is closed then it remains unlocked. Lock with the remote control or from inside to lock the both doors and the boot lid.



## Locking and unlocking

### Opening the boot lid mechanically

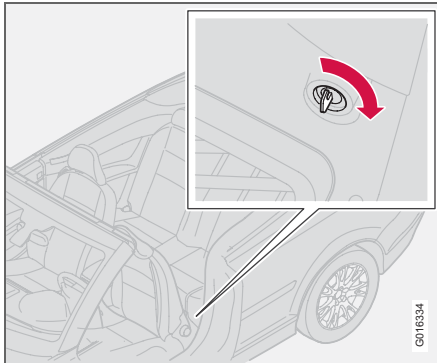

If the car's electrical systems are temporarily out of order then the boot lid can be opened mechanically with the remote control's detachable key blade. For information on removing the key blade, see page 98.

- Fold forward the left-hand seat's backrest to access the keyhole down at the floor.

Insert the key blade and turn it 110 degrees clockwise.



### IMPORTANT

The roof must be fully closed or fully open before mechanical opening can be used for the boot lid.

### Automatic relocking

If none of the doors or the boot lid is opened within two minutes of unlocking, all are locked again automatically (does not apply to locking from inside). This function prevents the car from being left unlocked unintentionally. For cars with alarms, see page 111.



## Locking and unlocking

### Locking/unlocking the car from inside

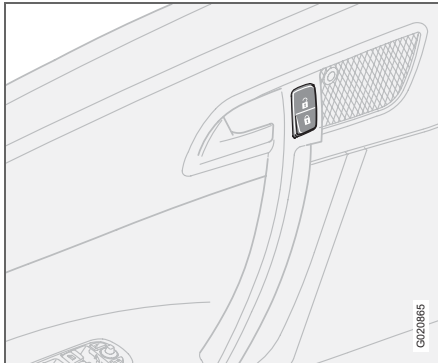

The doors and the boot lid can be locked or unlocked simultaneously using the lock button by the door handle.

### Unlocking

– Press the upper section of the lock button. The door cannot be unlocked by pulling up the lock button.

### Locking

– Press the lower section of the lock button.

### Opening the doors

When the doors are locked from the inside:

– Pull the handle twice to unlock and open the doors.

### Lock indicator

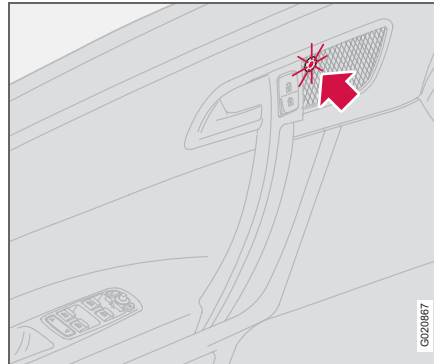

An LED on the inside of the door in question illuminates for approx. five minutes after the car has been locked with the remote control, or with the Keyless drive system when the engine is switched off, see page 103.

When the car is locked from the inside the LEDs acknowledge the locking with one long flash. Unlocking from the inside is acknowledged by two short flashes.

### Automatic locking

When the speed of the car exceeds 7 km/h the doors and boot lid can be locked automatically.

When the function is activated and the doors have been locked they can be opened in two ways:

- pull one of the door handles twice
- press the unlock button by the door handle.

The function can be activated/deactivated by means of personal preferences, see page 62.



## Locking and unlocking

### Deadlocks

When deadlocked, the doors cannot be opened from the inside if they are locked.

The deadlocks are activated with the remote control and are set after a 25 second delay after the doors have been locked.

The car can only be unlocked from a deadlock state with the remote control. The doors can also be opened from the outside with the key.

### Temporary deactivation

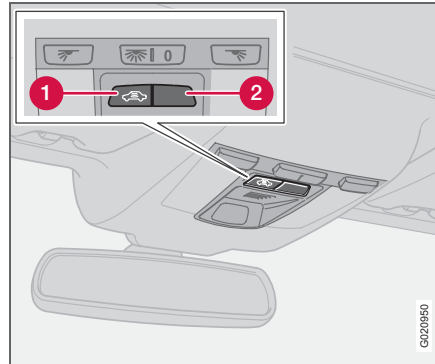

1. Deactivation of the deadlocks and detectors.
2. No function.

If someone is going to stay in the car but the doors must be locked from the outside, then the deadlocks function can be temporarily deactivated as follows:

- Insert the key into the ignition switch, turn it to position **II** and then back to position **I** or **0**.
- Press button (1).

If the car is equipped with an alarm with movement and tilt detectors, then these are also deactivated at the same time, see page 110.

The light in the button is illuminated until the car is locked with the key or the remote control.

#### NOTE

If the car is equipped with an alarm:  
Remember that the car's alarm is armed when the car is locked.  
If any of the doors are opened from the inside then the alarm will be triggered.

A message remains on the display as long as the key is in the ignition switch.

The detectors are reactivated and deadlocks re-engaged the next time the car is started.

#### WARNING

Do not allow anyone to remain in the car without first deactivating the deadlocks to avoid the risk of anyone being locked in.



## Alarm (option)

### Alarm system

When the alarm is armed, it continually monitors all alarm inputs.

The alarm is triggered if:

- a door, the bonnet or boot lid opens.
- a non-approved key is used in the ignition or if an attempt is made to force the lock.
- a movement is detected in the passenger compartment (if fitted with a movement detector).
- the car is raised or towed away (if fitted with a tilt detector).
- a battery cable is disconnected.
- anyone tries to disconnect the siren.



#### NOTE

When the roof is closed, the alarm functions in the same way as when it is open, i.e. movement detected in the passenger compartment triggers an alarm.

### Alarm light on instrument panel

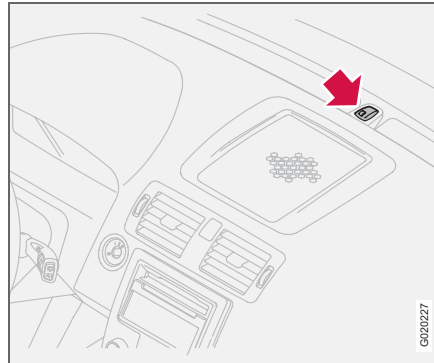

A light on the instrument panel indicates the alarm system's status:

- Light not illuminated – the alarm is not armed.
- The light flashes rapidly after disarming the alarm and until the ignition is switched on – the alarm has been triggered.
- The lamp flashes once every other second after the car's direction indicators have made one long flash signal – Alarm is armed.

If there is a fault in the alarm system, a message appears on the information display. Contact an authorised Volvo workshop.



#### NOTE

Do not attempt to repair or modify alarm system components. All such attempts could affect the terms of insurance.

### Arming the alarm

- Press the lock button on the remote control. A long flash from the car's direction indicators confirms that the alarm is armed and that the doors are locked.



#### IMPORTANT

The alarm is fully armed when the car's direction indicators have made one long flash and the light on the instrument panel flashes once every other second.

### Disarming the alarm

- Press the unlock button on the remote control. Two short flashes from the car's direction indicators confirm that the alarm is disarmed and that the doors are unlocked.



## Alarm (option)

### Automatic alarm activation

This function prevents you accidentally leaving the car without the alarm on.

If none of the doors or the boot lid is opened within two minutes of disarming the alarm (and the car has been unlocked with the remote control), then the alarm is automatically rearmed, and the car is locked at the same time.

### Deactivating a triggered alarm

- Press the unlock button on the remote control or insert the key in the ignition switch.

Confirmation is given by two short flashes from the direction indicators.

### Alarm signals

When the alarm is triggered, the following happens:

- A siren sounds for no more than 25 seconds. The siren has its own battery which is used if the car battery has insufficient charge or is disconnected.
- The direction indicators flash for five minutes or until the alarm is deactivated.

### Remote control not working

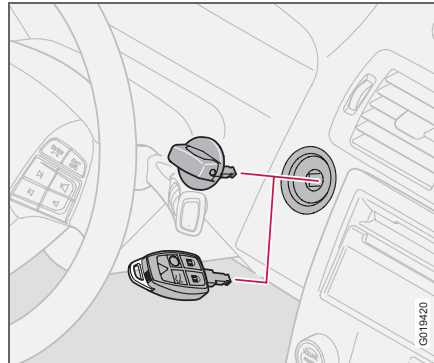

If for some reason the remote control is not working, the alarm can still be switched off and the car started as follows:

- Open the driver's door with the key blade. The alarm is triggered and the siren sounds.
- On cars with the keyless drive system: First remove the knob by pressing in the catch (1) and pulling out (2).
- Insert the remote control into the ignition switch (3). The alarm is deactivated. The alarm light flashes rapidly until the ignition key is turned to position II.





### Alarm (option)

#### Reduced alarm level

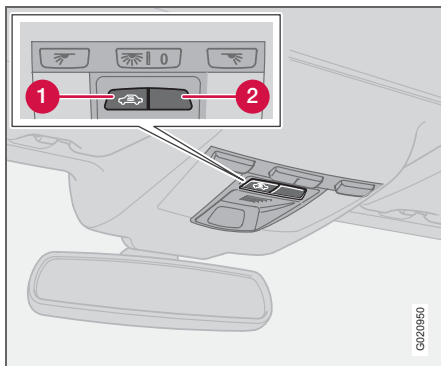

1. Deactivation of the deadlocks and detectors.
2. No function.

To avoid inadvertently triggering the alarm, for example during a ferry crossing, the movement and tilt detectors can be temporarily deactivated as follows:

- Turn the ignition key to position **II** and then back to position **0**. Remove the key.
- Press button (1). The light in the button is illuminated until the car is locked.

A message is shown on the display as long as the key remains in the ignition switch (and for one minute after the key is removed).

If the car is equipped with deadlocks, they are deactivated at the same time, see page 109.

The detectors are reactivated and deadlocks re-engaged the next time the car is started.

**Alarm (option)****Testing the alarm system****Testing the movement detector in the passenger compartment**

- Open all windows.
- Arm the alarm. Arming the alarm is confirmed by the light flashing slowly.
- Wait 30 seconds.
- Test the movement detector in the passenger compartment, such as by lifting out a bag from a seat. A siren should then sound and all direction indicators should flash.
- Deactivate the alarm by unlocking the car with the remote control.

**Testing the door alarm**

- Arm the alarm.
- Wait 30 seconds.
- Unlock the driver's door with the key blade.
- Open one of the doors. A siren should sound and all direction indicators flash.
- Deactivate the alarm by unlocking the car with the remote control.

**Testing the alarm for the bonnet**

- Sit in the car and deactivate the movement detector.

- Arm the alarm. Remain in the car and lock the doors with the button on the remote control.
- Wait 30 seconds.
- Open the bonnet with the handle under the dashboard. A siren should sound and all direction indicators flash.
- Deactivate the alarm by unlocking the car with the remote control.

General .....	116
Refuelling .....	118
Starting the engine .....	119
Diesel particle filter (DPF) .....	120
Ignition switch and steering lock .....	121
Keyless drive .....	122
Manual gearbox .....	123
Automatic gearbox .....	125
Brake system .....	128
DSTC – Stability and traction control system .....	130
Parking assistance (option) .....	132
BLIS – Blind Spot Information System (option) .....	135
Towing and recovery .....	138
Jump starting .....	140
Driving with a trailer .....	141
Towing equipment .....	143
Detachable towbar .....	145
Loading .....	150
Adjusting headlamp pattern .....	151

## STARTING AND DRIVING



# 06



## General

### Economical driving

Driving economically means driving smoothly while thinking ahead and adjusting your driving style and speed to the prevailing conditions.

- Get the engine warmed up as soon as possible.
- Do not let the engine idle, but drive at light loads as soon as it is possible.
- A cold engine consumes more fuel than a warm one.
- Avoid braking too hard.
- Do not drive with unnecessary loads in the car.
- Do not use winter tyres when the roads are dry.
- Remove load carriers when they are not being used.
- Avoid driving with open windows.

### Slippery driving conditions

Practise driving on slippery surfaces under controlled conditions to learn how the car reacts.

### Engine and cooling system

Under special conditions, for example when driving in hilly terrain, extreme heat or with heavy loads, there is a risk that the engine and cooling system will overheat.

### Avoid overheating the cooling system

- Maintain a low speed when driving with a trailer up long, steep ascents.
- Do not turn the engine off immediately you stop after a hard drive.
- Remove any auxiliary lamps from in front of the grille if driving in extreme high temperatures.

### Avoid overheating the engine

Do not exceed engine speeds of 4500 rpm (diesel engine: 3500 rpm) if driving with a trailer or caravan in hilly terrain. The oil temperature could then become too high.

### Open boot lid

Avoid driving with the boot lid open. If it is necessary to drive with the boot lid open for a short distance:

- Close all windows.
- Set the air distribution to the windscreen and floor and run the fan at high speed.



### WARNING

Do not drive with the boot lid open. Toxic exhaust fumes can be drawn into the car through the cargo area.

### Driving in water

The car can be driven through water at a maximum depth of 25 cm at a maximum speed of 10 km/h. Extra caution should be exercised when passing through flowing water.



### IMPORTANT

Engine damage can occur if water enters the air filter. In greater depths, water can enter the transmission. This reduces the lubricating ability of the oils and shortens the service life of these systems.

When driving in water, maintain a low speed and do not stop the car. When the water has been passed, depress the brake pedal lightly and check that full brake function is attained. Water and mud for example can make the brake linings wet resulting in delayed brake function.

Clean the electric contacts of the electric engine block heater and trailer coupling after driving in water and mud.



### IMPORTANT

Do not let the car stand with water over the sills for any long period of time. This could cause electrical malfunctions. In the event of stalling in water, do not try to restart. Tow the car out of the water.



### Do not overload the battery

The electrical functions in the car load the battery to varying degrees. Avoid using the ignition position II when the engine is switched off. Use ignition position I instead, as less power is consumed.

The 12 volt outlet in the cargo area supplies power even when the ignition key is removed.

Examples of functions that use a lot of power:

- ventilation fan
- windscreen wipers
- audio equipment (high volume)
- parking lamps

Also, be aware of different accessories that load the electrical system. Do not use functions which use a lot of power when the engine is switched off.

If the battery voltage is low, a message appears on the display. The energy-saving function shuts down certain functions or reduces the load on the battery by, for example, slowing the ventilation fan and switching off the audio equipment. Charge the battery by starting the engine.

## Refuelling

### Opening the fuel filler flap

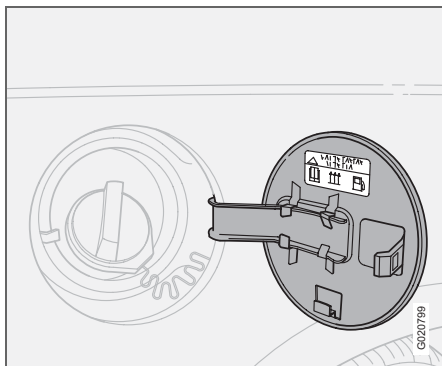

Switch off the fuel-driven heater before refuelling.

Open the fuel filler flap with the button on the lighting panel, see page 47. The engine must be switched off before the flap can be opened. The fuel flap is located on the rear right wing.

### Closing

Push in the flap until you hear a click.

### Fuel cap

- Turn the fuel cap until an obvious resistance is felt.
- Turn past the resistance until it comes to a stop.

- Take out the cap.
- Hang up the cap on the inside of the fuel filler flap.

### NOTE

Put the petrol cap back after refuelling. Turn until one or more clear clicks are heard.

### Opening from the cargo area

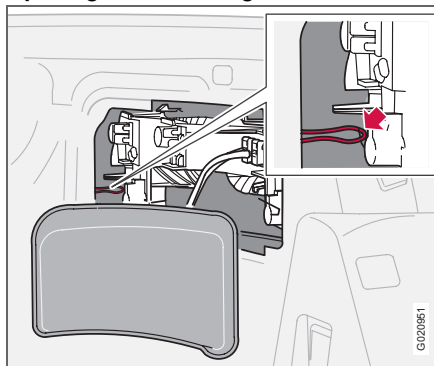

Manual opening of the fuel filler flap is easier when the roof is closed, and is used when it is not possible to open it from the passenger compartment.

Remove the cover over the lamp housing on the right-hand side of the cargo area.

Pull the cord hanging on the hook.

When the fuel filler flap has opened, refit the cord and cover.

### Filling up with fuel

Do not overfill the tank but fill until the pump nozzle cuts out.

### NOTE

Excess fuel in the tank can overflow in hot weather.

Fuel of a lower quality than that specified on page 243 should not be used as engine power and fuel consumption can be negatively affected.

### WARNING

Fuel which spills onto the ground can be ignited by the exhaust fumes.

Switch off the fuel-driven heater before starting to refuel.

Never carry an activated mobile phone when refuelling as the ring signal could cause spark build-up and ignite petrol fumes, leading to fire and injury.

**Starting the engine****Petrol****! IMPORTANT**

Do not add cleaning additives to the petrol, unless recommended by Volvo.

**Diesel**

At low temperatures (–5 °C to –40 °C), a paraffin precipitate may form in the diesel fuel, which can lead to ignition problems.

**! IMPORTANT**

Use special winter grade fuel during cold months.

**Before starting the engine**

- Apply the parking brake.

**Automatic gearbox**

- Gear selector in position **P** or **N**.

**Manual gearbox**

Put the gear lever in neutral and hold the clutch pedal fully depressed. This is particularly important in very cold conditions.

**! WARNING**

Never remove the ignition key from the steering lock while driving or when the car is being towed. The steering lock could otherwise be activated, making it impossible to steer the car.

The ignition key must be in position **II** when the car is being towed.

**i NOTE**

The idling speed can be noticeably higher than normal for certain engine types during cold starting. This is so that the emissions system can reach normal operating temperature as quickly as possible, which minimises exhaust emissions and protects the environment.

**Starting the engine****Petrol**

- Turn the ignition key to position **III**. If the engine does not start within 5–10 seconds, release the key and try again.

**Diesel**

- Turn the ignition key to position **II**. An indicator symbol in the combined instrument panel shows that engine preheating is underway, see page 41.
- Turn the ignition key to position **III** when the indicator symbol goes out.

**Autostart (5-cylinder)**

With the autostart function, there is no need to hold the ignition key (or ignition dial on cars with Keyless Drive, see page 122) in position **III** until the engine has started.

Turn the ignition key to the start position and then release. The starter motor then works automatically until the engine has started.

**i NOTE**

If the diesel engine is started in extreme cold without waiting for engine preheating, then the automatic start sequence can be delayed for a couple of seconds.





## Diesel particle filter (DPF)

### Diesel particle filter (DPF)<sup>1</sup>

Diesel cars may be equipped with a particle filter, which results in more efficient emission control. The particles in the exhaust gases are collected in the filter during normal driving. So-called "regeneration" is started in order to burn away the particles and empty the filter. This requires the engine to have reached normal operating temperature.

Regeneration of the filter takes place automatically at an interval of 300 – 900 km depending on driving conditions. Regeneration normally takes between 10 and 20 minutes. During this time fuel consumption may increase slightly.

The rear window heating may be activated automatically to increase the load on the engine during regeneration without warning.

### Regeneration in cold weather

If the car is frequently driven short distances in cold weather then the engine does not reach normal operating temperature. This means that regeneration of the diesel particle filter does not take place and the filter is not emptied.

When the filter has become approximately 80 % full of particles, the yellow information

symbol on the dashboard illuminates, and the message **SOOT FILTER FULL SEE OWNER MANUAL** is shown on the dashboard display.

Start regeneration of the filter by driving the car until the engine reaches normal operating temperature, preferably on a main road or motorway. The car should then be driven for approximately 20 minutes more.

When regeneration is complete the message is cleared automatically.



### IMPORTANT

If the filter fills up it may be incapable of functioning. Then it can be difficult to start the engine and there is a risk that the filter will have to be replaced.

Use the parking heater (option) in cold weather so that the engine reaches normal operating temperature more quickly.

<sup>1</sup> Certain markets.



## Ignition switch and steering lock

### Ignition keys and electronic immobiliser

The ignition key must not hang with other keys or metal objects on the same key ring. The electronic immobiliser could be activated accidentally.

### Ignition switch and steering lock

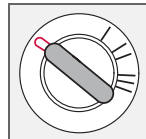

#### 0 – Locked position

The steering lock is activated when the key is removed from the lock.

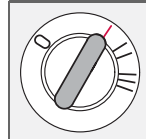

#### I – Radio position

Certain electrical components can be switched on. The engine's electrical system is not activated.

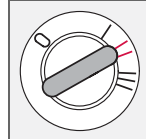

#### II – Driving position

The key position when driving. The car's electrical system is energised.

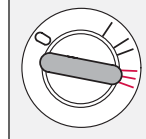

#### III – Start position

The starter motor is engaged. Release the key, which springs back automatically to the driving position, once the engine has started.

A ticking sound may be heard if the key is between positions. Turn the key to position II and back to eliminate the sound.

### When the steering lock is activated

If the front wheels are positioned so that there is tension in the steering lock, a warning message may be shown on the information display and the car prevented from starting.

- Remove the key and turn the steering wheel to release the tension.
- Hold the steering wheel in this position. Reinsert the key and make a new attempt to start the car.



#### WARNING

Never remove the ignition key from the ignition switch while driving or when the car is being towed. The steering lock could otherwise be activated, making it impossible to steer the car.



#### WARNING

Always remove the ignition key from the ignition when leaving the car, especially if there are children in the car.

Make sure the steering lock is activated when the car is left to reduce the risk of theft.



## Keyless drive

### General

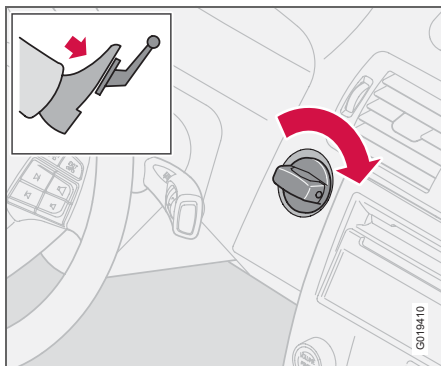

The keyless drive function allows the car to be unlocked, driven and locked without the need for a key, see page 102.

The ignition switch ignition dial is used in the same way as the key. One precondition for starting the car is that the car's remote control is located inside the passenger compartment or the cargo area.

### Starting the car

- Depress the clutch pedal (cars with manual gearbox) or brake pedal (cars with automatic gearbox).

#### Petrol engine

- Press in and turn the ignition dial to position **III**.

#### Diesel engine

- First turn the ignition dial to position **II** and wait until the diesel indicator symbol in the combined instrument panel goes out, see page 41.
- Following which, turn the ignition dial to position **III**.

### Starting with the remote control

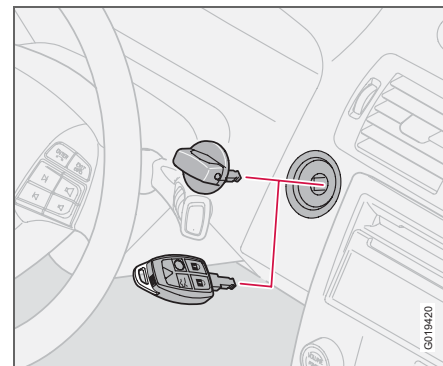

If the remote control battery is discharged then the Keyless Drive function does not work. In which case, start the car by using the remote control as ignition dial.

1. Press in the catch in the ignition dial.
2. Pull the ignition dial out from the ignition switch.
3. Insert the remote control into the ignition switch and start in the same way as with the ignition dial.



## Manual gearbox

## Gear positions, five-speed

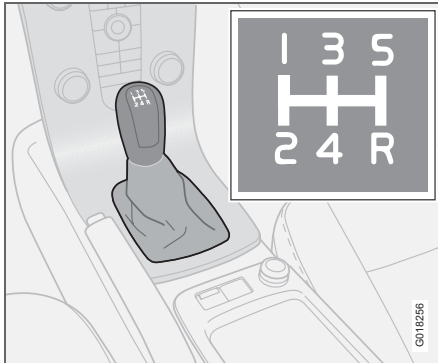

Depress the clutch pedal fully with each gear change. Remove your foot from the clutch pedal between gear changes! Follow the appropriate shifting pattern.

For the best possible fuel economy, use the highest gear possible as often as possible.

## Reverse gear inhibitor, five-speed

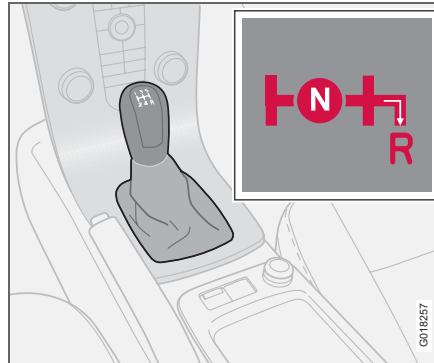

Only engage reverse gear when the car is stationary. To engage reverse gear, the gear lever must first be put in position **N**. Reverse gear cannot therefore be engaged directly from fifth gear due to the reverse gear inhibitor.

## Gear positions, six-speed (petrol)

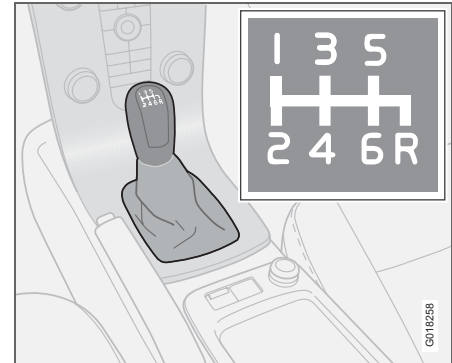

Depress the clutch pedal fully with each gear change. Remove your foot from the clutch pedal between gear changes! Follow the appropriate shifting pattern.

For the best possible fuel economy, use the highest gear possible as often as possible.

It can be difficult to find the positions for fifth and sixth gear when the car is stationary as the reverse gear inhibitor (which blocks sideways movement towards reverse) is then not activated.



## Manual gearbox

### Reverse gear inhibitor, six-speed (petrol)

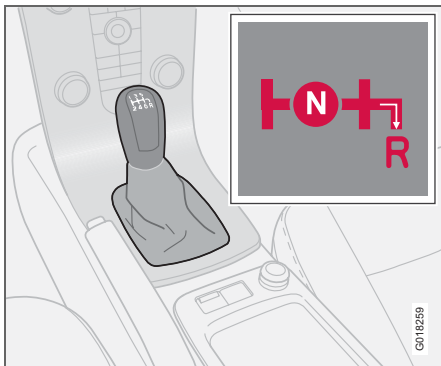

Only engage reverse gear when the car is stationary.

#### NOTE

Reverse gear is electronically blocked if the car is travelling faster than approx. 20 km/h.

### Gear positions, six-speed (diesel)<sup>1</sup>

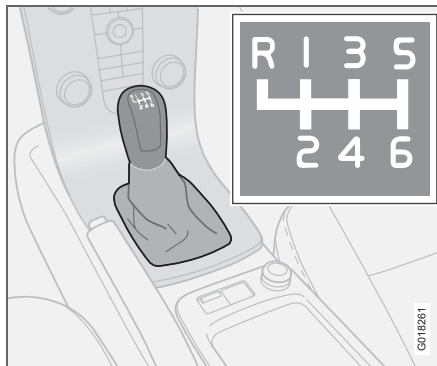

Depress the clutch pedal fully with each gear change. Remove your foot from the clutch pedal between gear changes! Follow the appropriate shifting pattern.

For the best possible fuel economy, use the highest gear possible as often as possible.

### Reverse gear inhibitor, six-speed (diesel)

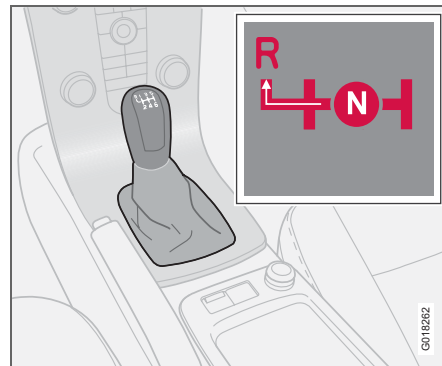

Only engage reverse gear when the car is stationary. Engage reverse gear by pressing down the gear lever and moving it to the left.

<sup>1</sup>Certain markets.



## Automatic gearbox

### Geartronic automatic gear positions

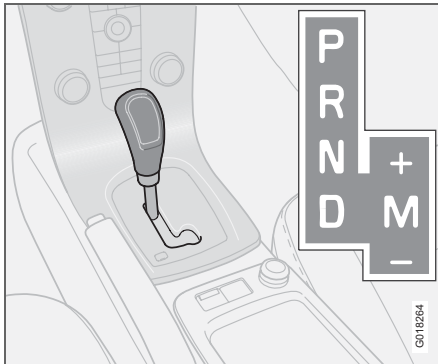

#### P – Parking position

Select position **P** when you wish to start the engine or park the car.

#### ! IMPORTANT

The car must be stationary when position **P** is selected.

#### i NOTE

The brake pedal must be depressed to move the gear lever from the **P** position.

The gearbox is mechanically blocked when **P** position is engaged. Always apply the parking brake when parking the car.

#### R – Reverse

The car must be stationary when **R** is selected.

#### N – Neutral

No gear is engaged and the engine can be started. Apply the parking brake when the car is stationary with the gear selector in position **N**.

#### D – Drive

**D** is the normal driving position. The car automatically shifts up and down depending on the level of acceleration and speed. The car should be stationary when **D** is selected from position **R**.

### Geartronic manual gear positions

The driver can also change gear manually using the Geartronic automatic gearbox. The car engine-brakes when the accelerator pedal is released.

Manual gearshift mode is obtained by moving the lever from position **D** to the right-hand end position at **M**. The information display shifts the indication from **D** to one of the figures **1-6**, depending which gear is engaged just then, see page 39.

Move the lever forwards towards **+** (plus) to change up a gear and release the lever, which returns to its rest position at **M**. Pull the lever back towards **-** (minus) to change down a gear and release the lever.

The manual gearshift mode **M** can be selected at any time while driving.

To return to automatic driving mode: move the lever to the left-hand end position at **D**.

Geartronic automatically shifts down if the driver allows the speed to decrease lower than a level suitable for the selected gear, in order to avoid jerking and stalling.



## Automatic gearbox

### Kick-down<sup>1</sup>

When the accelerator pedal is pressed all the way to the floor (beyond the position normally regarded as full acceleration) a lower gear is immediately engaged. This is known as kick-down.

If the accelerator is released from the kick-down position, the gearbox automatically changes up.

Kick-down is used when maximum acceleration is needed, such as for overtaking.

### Safety function

To prevent overrevving the engine, the gearbox control program has a protective downshift inhibitor which prevents the kick-down function.

Geartronic does not permit downshifting/kick-down which would result in an engine speed high enough to damage the engine. Nothing happens if the driver still tries to shift down in this way at high engine speed – the original gear remains engaged.

When kick-down is activated the car can change one or more gears at a time depending on engine speed. The car changes up when the engine reaches its maximum speed in order to prevent damage to the engine.

<sup>1</sup> Not on diesel cars in manual position.

### Mechanical gear selector inhibitor

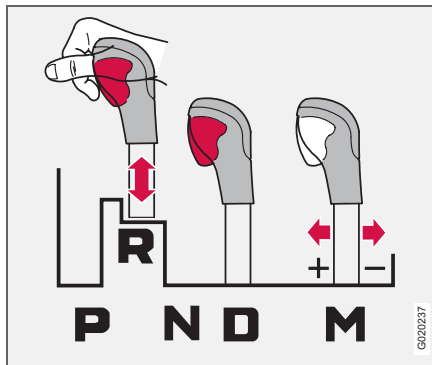

The gear selector can be moved forward and back freely between **N** and **D**. Other positions are locked with a latch that is released with the inhibitor button on the gear selector.

With the inhibitor button depressed the lever can be moved forwards or backwards between **P**, **R**, **N** and **D**.

### Automatic gear selector inhibitor

Cars with an automatic gearbox have special safety systems:

#### Keylock

To remove the ignition key, the gear selector must be in the **P** position. The key is locked in all other positions.

#### Parking position (P)

Stationary car with engine running:

- Hold your foot on the brake pedal when moving the gear selector to another position.

#### Electric gear inhibitor – Shiftlock

##### Parking position (P position)

To be able to move the gear selector from the **P** position to other gear positions, the ignition key must be in position **II** and the brake pedal must be depressed.

##### Shiftlock – Neutral (N position)

If the gear selector is in the **N** position and the car has been stationary for at least three seconds (irrespective of whether the engine is running) then the gear selector is locked in the **N** position.

To be able to move the gear selector from the **N** position to another gear position, the brake pedal must be depressed and the ignition key must be in position **II**.



## Automatic gearbox

### Disengaging the gear selector inhibitor

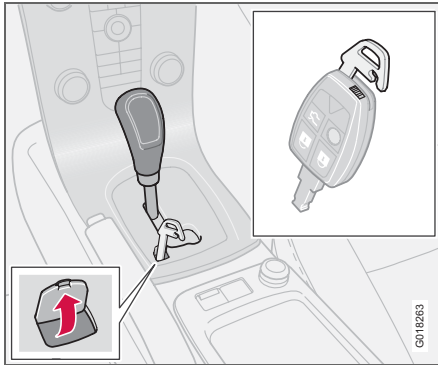

In certain cases, it may be necessary to move the car when it is not driveable, for example if the battery is flat. Proceed as follows to move the car:

1. There is a small cover behind **P-R-N-D** on the gear selector panel. Open the rear edge.
2. Fully insert the key blade from the remote control.
3. Hold the key blade down and at the same time move the gear lever out of the **P** position.

### Cold start

When starting in low temperatures, the gear changes can sometimes feel hard. This is due to the gearbox oil's viscosity at low temperatures. To minimise engine emissions, the gearbox shifts up later than normal when the engine is started at low temperatures.

#### **i** NOTE

Depending on the engine temperature when the engine is started, the idle speed after a cold start may be higher than normal for certain engine types.





## Brake system

### Brake servo

If the car is rolling or is being towed with the engine turned off, the brake pedal must be pressed about five times harder than when the engine is running. If the brake pedal is pressed when the engine is started, you will feel the pedal drop. This is normal and due to the brake servo becoming active. This may be more noticeable if the car has emergency brake assistance (EBA).



### WARNING

The brake servo only works when the engine is running.



### NOTE

If braking with the engine switched off, press the brake pedal sharply once, not repeatedly.

### Brake circuits



This symbol illuminates if a brake circuit is not working.

If a fault should occur in one of the circuits, it is still possible to brake the car. The brake pedal will travel further and may feel softer than normal. Harder pressure on the pedal is needed to produce the normal braking effect.

### Dampness can affect braking characteristics

Brake components become wet when the car is driven in heavy rain, through pools of water or when the car is washed. This may alter brake pad friction characteristics so that there is a delay before braking effect is noticed.

Press the brake pedal lightly from time to time if driving for long stretches in rain or slushy snow, as well as after setting off in very damp or cold weather. This warms up the braking surfaces and dries off any water. It is also recommended to do this before parking the car for a long period in such weather conditions.

### If the brakes are used heavily

When driving in the Alps or other roads with similar characteristics, the car's brakes are heavily loaded even if the brake pedal is not being depressed especially hard.

Because speed is often low, the brakes are not cooled as effectively as when driving on flat roads at higher speed.

So as not to overload the brakes, shift down when driving downhill instead of using the foot brake. Use the same gear driving downhill as you would use driving uphill. This uses

engine braking more efficiently and requires the foot brake for only brief periods.

Bear in mind that driving with a trailer puts an additional load on the car's brakes.

### Anti-lock braking system (ABS)



The anti-lock braking system (ABS) prevents the wheels from locking up under braking.

This means the ability to steer is maintained and it is easier to swerve to avoid a hazard, for example.

After the engine has been started, the ABS will perform a brief self-test at a speed of about 20 km/h. This can be felt and heard as pulses in the brake pedal.

To get the most out of the ABS:

- Press brake pedal with full force. Pulses will be felt.
- Steer the car in the direction of travel. Do not release the pressure on the pedal.

Practice braking with the ABS system in a traffic-free area and in different weather conditions.

The ABS symbol illuminates for two seconds if there was a fault in the ABS system when the engine was last running.



### Emergency brake assistance – EBA

(Emergency brake assistance) In case of sudden braking, full-strength braking is provided instantaneously. The EBA function senses when heavy braking is underway by registering how quickly the brake pedal is depressed. Continue braking without easing off on the brake pedal. The function is suspended when the pressure on the brake pedal eases. This function is always active and cannot be disengaged.



#### NOTE

When the EBA function is activated, the brake pedal sinks slightly more than usual, press (and hold) the brake pedal as long as necessary. Release the brake pedal to stop all braking.



#### WARNING

If the BRAKE and ABS warning symbols are illuminated at the same time, a fault may have occurred in the brake system. If the level in the brake fluid reservoir is normal, drive carefully to the nearest authorised Volvo workshop to have the brake system checked.

If the brake fluid is under the MIN level in the brake fluid reservoir, do not drive further before topping up the brake fluid.

The reason for the loss of brake fluid must be investigated.



## DSTC – Stability and traction control system

### General

The Dynamic Stability and Traction Control system (DSTC) improves the car's traction and helps the driver to avoid skidding.

A pulsing sound may be noticed during braking or acceleration when the system is in action. The car may accelerate more slowly than expected.

### Active Yaw Control

The function limits the driving and brake force of the wheels individually in order to stabilise the car.

### Spin Control

The function prevents the driving wheels from spinning against the road surface during acceleration.

### Traction control system

The function is active at low speed and transfers power from the driving wheel that is spinning to the one that is not.

### Reduced operation

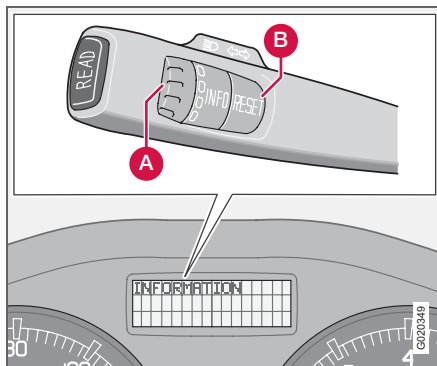

The stability system is activated automatically each time the car is started.

System operation during skidding and acceleration can be partially deactivated.

Operation during skidding is delayed and so allows more skidding which provides greater freedom for dynamic driving.

Traction in deep snow or sand is improved as acceleration is no longer limited.

### Operation

– Turn thumbwheel (A) until the DSTC menu is shown.

**DSTC ON** means that the system function is unchanged.

**DSTC SPIN CONTROL OFF** means that system operation is reduced.

– Press and hold **RESET** (B) until the DSTC menu is changed.

At the same time the symbol  illuminates as a reminder that the system has been reduced. The system remains reduced until the engine is next started.



### WARNING

Suppressing system function may alter the driving characteristics of the car.



### NOTE

**DSTC ON** is shown for several seconds in the display and the  symbol illuminates each time the engine is started.



## DSTC – Stability and traction control system

### Messages in the information display

**TRACTION CONTROL TEMPORARILY OFF** means that the system has been temporarily reduced due to excessive brake disc temperature.

The function is reactivated automatically when the brakes have cooled.

**ANTI-SKID SERVICE REQUIRED** means that the system has been disabled due to a fault.

- Stop the car in a safe place and turn off the engine.

If the message remains when the engine is restarted, drive to an authorised Volvo workshop.



### Symbols in the combined instrument panel



**DSTC system**



**Information**

If the symbols  and  are displayed at the same time, read the message on the information display.

If the symbol  appears alone then it may appear as follows:

- Flashing light means that the DSTC system is now being activated.
- Constant glow for two seconds means system check when the engine is started.
- Constant glow after starting the engine or while driving means that there is a fault in the DSTC system.
- Constant glow after deactivation reminds that the DSTC system has been reduced.



## Parking assistance (option)

### General information on parking assistance<sup>1</sup>

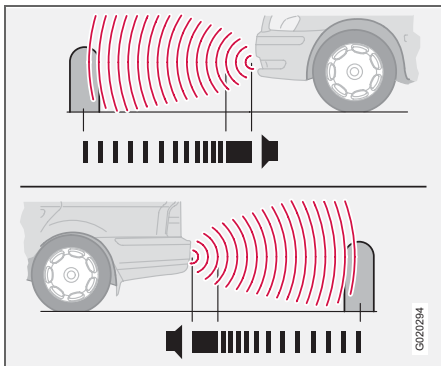

Parking assistance front and rear.

Parking assistance is used as an aid to parking. A signal indicates the distance to a detected obstacle.

### **WARNING**

Parking assistance does not relinquish the driver's own responsibility during parking. The sensors have blind spots where obstacles cannot be detected. Be aware of children and animals near the car.

<sup>1</sup> Depending on the market, the **Parking assistance system** may be either standard, option or accessory.

### Variants

Parking assistance is available in two variants:

- Rear only
- Both front and rear.

### Function

The frequency of the signal increases the shorter the distance to an obstacle in front of or behind the car. If the volume of another sound source from the audio system is high, this is automatically muted.

The tone becomes constant at a distance of about 30 cm. If there are obstacles within this distance both behind and in front of the car, the signal alternates between left and right-hand speakers.

### Rear parking assistance only

The system is automatically engaged when the car is started.

Rear parking assistance is activated when reverse gear is engaged and the message **Park Assist active, Exit to deactivate** is shown on the audio system display.

If the system is switched off, the display shows **Park Assist deactivated Enter to activate** as soon as reverse gear is engaged. To change the settings, see page 62.

The distance covered behind the car is about 1.5 metres. The signal comes from the rear loudspeakers.

### Limitations

The system must be deactivated when reversing with a trailer, or bike carrier on the towbar or similar. Otherwise the trailer or bike carrier would trigger the sensors.

### **NOTE**

Rear parking assistance is deactivated automatically when towing a trailer if a Volvo genuine trailer cable is used.



## Parking assistance (option)

### Parking assistance both front and rear

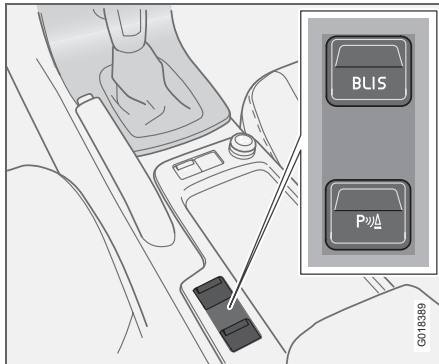

Button for Off/On (here lowest button).

The system is automatically activated when the car is started and the lamp in the switch for Off/On is illuminated. If parking assistance is deactivated with the button, then the lamp goes out.

#### Front

Front parking assistance is active at speeds below 15 km/h. The system is deactivated at higher speeds. The system is reactivated when the speed falls below 10 km/h again.

The distance covered to the front of the car is about 0.8 metres. The signal for obstacles in front comes from the front loudspeakers.

#### Limitations

Front parking assistance cannot be combined with auxiliary lamps because the sensors are affected by the auxiliary lamps.

#### Rear

Rear parking assistance is activated when reverse gear is engaged.

The distance covered to the rear of the car is about 1.5 metres. The signal for obstacles behind comes from the rear loudspeakers.

#### Limitations

See the previous section *Rear parking assistance only*.

#### Fault indicator



If the information symbol illuminates with constant glow and the display shows **PARK ASSIST SERVICE REQUIRED** then parking assistance is disengaged.

Contact an authorised Volvo workshop for attention.



#### IMPORTANT

In certain conditions the parking assistance system may produce incorrect warning signals that are caused by external sound sources that emit the same ultrasonic frequencies that the system works with.

Examples of such sources include horns, wet tyres on asphalt, pneumatic brakes and exhaust noises from motorcycles etc.



### Parking assistance (option)

#### Cleaning the sensors

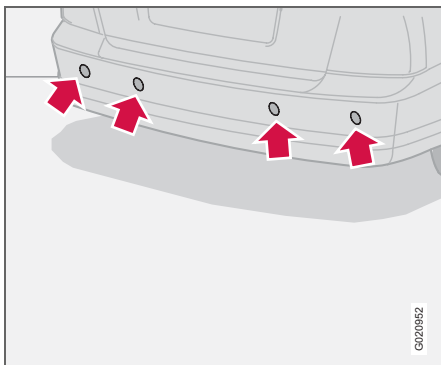

*Parking assistance sensors.*

The sensors must be cleaned regularly to ensure that they work properly. Clean them with water and car shampoo.

#### NOTE

Dirt, ice and snow covering the sensors may cause incorrect warning signals.



## BLIS – Blind Spot Information System (option)

### General

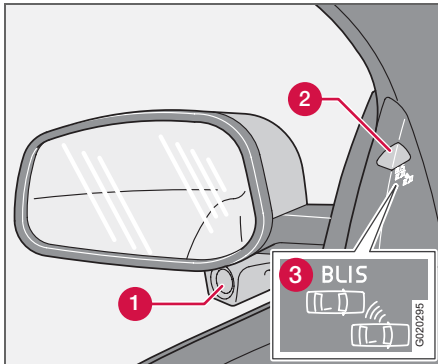

Rearview mirror with BLIS system.

1. BLIS camera
2. Indicator lamp
3. BLIS symbol



### WARNING

The system is a supplement to, not a replacement for, a safe driving style and use of the rearview mirrors. It can never replace the driver's attention and responsibility. The responsibility for changing lanes safely always rests with the driver.

BLIS is an information system that under certain conditions can help to draw the driver's

attention to vehicles moving in the same direction in the so-called "blind spot".

The system is designed to work most effectively when driving in dense traffic on multi-lane highways.

BLIS is based on digital camera technology. The cameras (1) are located under the door mirrors.

When a camera has detected a vehicle inside the blind spot zone the indicator lamp (2) illuminates with a constant glow.



### NOTE

The light illuminates on the side of the car where the system has detected the vehicle. If the car is overtaken on both sides at the same time then both lights illuminate.

BLIS advises the driver with a message if a fault arises in the system. If for example the system's cameras are obscured then the BLIS indicator lamp flashes and the instrument panel's display shows a message. In such cases, check and clean the lenses. If necessary, the system can be switched off temporarily by pressing the **BLIS** button, see page 136.

### Blind spots

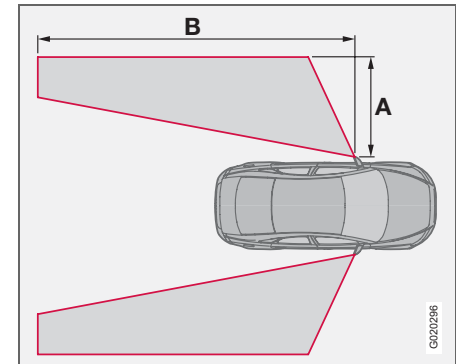

$A = \text{approx. } 3.0 \text{ m}$ ,  $B = \text{approx. } 9.5 \text{ m}$

### When BLIS operates

The system operates when the car is driven at a speed above 10 km/h.

### Overtaking

The system is designed to react if you overtake another vehicle at a speed of up to 10 km/h faster than the other vehicle.

The system is designed to react if you are overtaken by a vehicle travelling up to 70 km/h faster than your vehicle.





## BLIS – Blind Spot Information System (option)

### **WARNING**

BLIS does not work in sharp bends.

BLIS does not work when the car is reversing.

A wide trailer coupled to the car can conceal other vehicles in adjacent lanes. It can prevent the vehicle in the screened area from being detected by BLIS.

### **Daylight and darkness**

In daylight the system reacts to the shape of the surrounding vehicles. The system is designed to detect motor vehicles such as cars, trucks, buses and motorcycles.

In darkness the system reacts to the headlamps of surrounding vehicles. Vehicles with headlamps that are switched off are not detected by the system. This means for example that the system does not react to a trailer without headlamps which is towed behind a car or truck.

### **WARNING**

The system does not react to bicycles or mopeds.

The BLIS cameras can be disrupted by intensive light or when driving in the dark when there are no light sources (e.g. street lighting or other vehicles). The system may then interpret the lack of light as if the cameras have been blocked.

In both cases a message is shown on the information display.

When driving in such conditions system performance may be temporarily reduced and a text message is shown, see page 137.

If the message disappears automatically then BLIS has returned to normal functionality.

The BLIS cameras have limitations similar to the human eye, i.e. they "see" worse in heavy snowfall or thick fog for example.

### **Activating/deactivating**

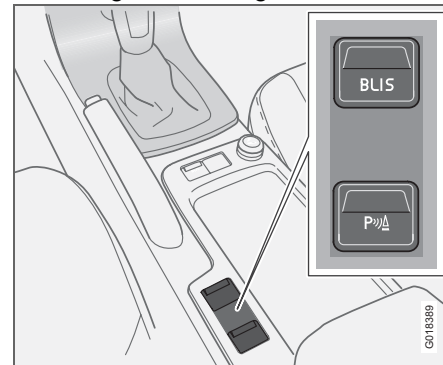

*Button for activating/deactivating.*

BLIS is activated when the engine is started. The indicator lamps in the door panels flash three times when BLIS is activated.

The system can be deactivated/activated by pressing **BLIS**.

When BLIS is deactivated the light in the button goes out and a text message is shown on the dashboard display.

When BLIS is activated the light in the button illuminates, a new text message is shown on the display and the indicator lamps in the door panels flash three times. Press the **READ** button to clear the text message. For more information on messages, see page 44.



## BLIS – Blind Spot Information System (option)

### BLIS system message

Text on the display	Specification
<b>BLIND-SPOT INFO SYSTEM ON</b>	BLIS system on.
<b>BLIS FUNCTION REDUCED</b>	The BLIS camera is disrupted by fog or strong sunlight, for example, shining directly into the camera. The camera resets itself when the environment has returned to normal.
<b>BLIND-SPOT SYST CAMERA BLOCKED</b>	One or both cameras blocked. Clean the lenses.
<b>BLIND-SPOT SYST SERVICE REQUIRED</b>	Blind spot syst. disengaged. Contact an authorised Volvo workshop.
<b>BLIND-SPOT INFO SYSTEM OFF</b>	BLIS system off.

### ! IMPORTANT

Repair of the BLIS system components must only be performed by an authorised Volvo workshop.

### Cleaning

In order to work most effectively the BLIS camera lenses must be clean. The lenses can be cleaned with a soft cloth or damp sponge. Clean the lenses carefully so that they are not scratched.

### ! IMPORTANT

The lenses are electrically heated to melt ice or snow. If necessary, brush snow away from the lenses.

### Limitations

In some situations the BLIS indicator lamp may illuminate despite there being no other vehicle within the blind spot.

### i NOTE

If the BLIS indicator lamp illuminates on isolated occasions despite there being no other vehicle within the blind spot then this does not mean that a fault has arisen in the system.

In the event of a fault in the BLIS system the display shows the text **BLIS Serv. required.**

Here are several examples of situations where the BLIS indicator lamp may illuminate even if there is no other vehicle within the blind spot.

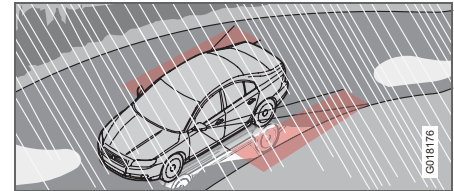

Reflection from shiny wet road surface.

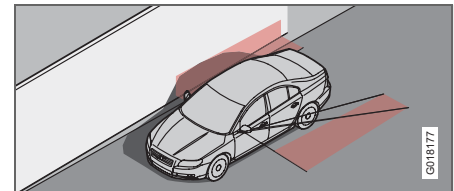

Own shadow on large, light, smooth surface, e.g. noise barrier or concrete road surface.

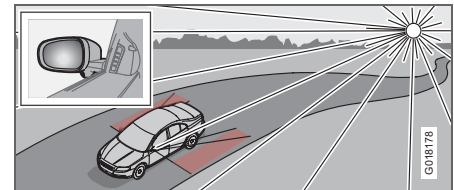

Low sun in the camera.



## Towing and recovery

### Never tow the car to bump start it

Jump start the car with a donor battery if the battery is flat and the engine does not start. Do not bump start the car.

#### IMPORTANT

Bump starting the car can damage the catalytic converter.

### Towing

Find out the highest legal speed for towing before towing the car.

- Turn the ignition switch to position **II** and unlock the steering lock so that the car can be steered, see page 121.
- The ignition key must remain in position **II** while the car is being towed.

### Automatic gearbox

- Move the gear selector to position **N**.

### Manual gearbox

- Move gear lever into neutral.
- Ensure the tow rope is always taut to avoid violent jerks. Keep your foot on the brake pedal.

Cars with automatic gearbox must not be towed at speeds above 80 km/h or further

than 80 km. The car must always be towed facing forward.

#### WARNING

The steering lock stays in the position it was in when the power was cut off. The steering lock must be unlocked before towing.

The ignition key must be in position **II**. Never remove the ignition key from the ignition switch while driving or when the car is being towed.

#### NOTE

If the car is de-energised then the steering lock must be unlocked using a donor battery before towing can be started.

#### WARNING

The brake servo and power steering do not work when the engine is switched off. The brake pedal must be pressed about five times harder than normal, and the steering will be considerably heavier than normal.

### Recovery

If only partially raised, cars with automatic gearbox must not be transported at speeds above 80 km/h or further than 80 km. During such transport, the wheels must always roll forward.



## Towing and recovery

## Towing eye

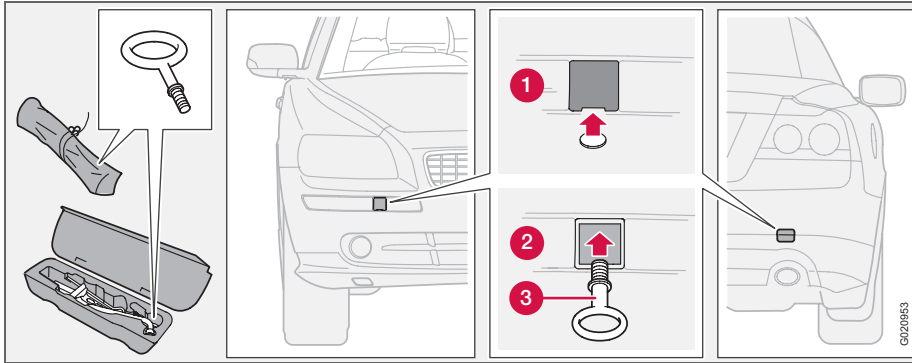

Use the towing eye if the car needs to be towed on the road. The towing eye is attached in the recess on the right-hand side of the front or rear bumper.

**Fitting the towing eye**

- Take out the towing eye which is located in the bag in the ski hatch or together with the spare wheel.
- Release the cover (1) on the bumper by pressing on the marking on the lower edge of the cover.
- Screw in the towing eye (3) firmly, right in up to the flange. Use the wheel wrench to tighten the towing eye.

- After use, unscrew the towing eye and return it in the cargo area. Refit the cover on the bumper.

**!** **IMPORTANT**

The towing eye is only designed for towing on roads, not for pulling the car unstuck or out of a ditch. Call a recovery service for assistance.

**i** **NOTE**

On certain cars with fitted towbar the towing eye cannot be secured in the rear mounting. In which case, secure the tow rope in the towbar.

For this reason it is advisable to store the towbar's towball in the car, see page 148.



## Jump starting

### Starting with a donor battery

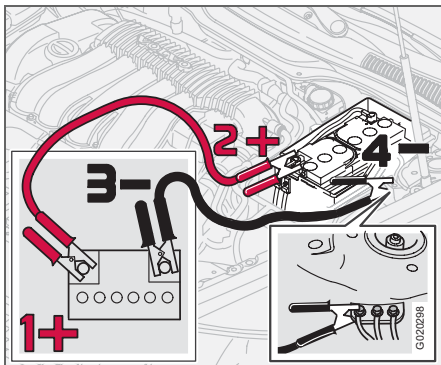

If the battery in the car has become flat, you can "borrow" electric current from either a separate battery or the battery in another car. Always make sure the crocodile clips on the jump leads are attached securely to eliminate sparks during the start attempt.

When jump starting the car, the following steps are recommended to avoid risk of explosion:

- Turn the ignition key to position 0.
- Ensure that the donor battery is 12 volt.
- If the donor battery is in another car, switch off the engine in the other car and ensure that the cars do not touch one another.

- Connect the red jump lead between the positive terminal on the donor battery (1+) and the one on the battery of your car (2+).
- Connect one of the clamps from the black jump lead to the donor battery's negative terminal (3-).
- Connect the other end of the black jump lead to the earthing point (4-) by the left-hand strut tower.
- Start the engine of the "donor car". Let the engine run a few minutes at a speed slightly higher than idle (1500 rpm).
- Start the engine of the car with the flat battery.
- Remove the jump leads, first the black and then the red. Ensure that neither of the black jump lead's clips comes into contact with the battery's positive terminal or the crocodile clip on the red jump lead.



### IMPORTANT

Do not touch the crocodile clips during the start procedure. This could cause sparking.



### WARNING

The battery can generate oxyhydrogen gas, which is highly explosive. One spark, which can be generated if you connect the jump leads incorrectly, is sufficient to make the battery explode.

The battery contains sulphuric acid, which can cause serious burns. If the acid comes into contact with eyes, skin or clothing, flush with large quantities of water.

If acid splashes into the eyes, seek medical attention immediately.

**Driving with a trailer****General**

The load capacity is affected by extra accessories mounted on the car, such as a towbar, load carriers, space box, the passengers' combined weight etc. as well as the load on the towball. The load capacity of the car is reduced by the number of passengers and their weight.

If the towing bracket is fitted by an authorised Volvo workshop, then the car is delivered with the necessary equipment for driving with a trailer.

- The car's towing bracket must be of an approved type.
- If the towbar is retrofitted, check with your Volvo dealer that the car is fully equipped for driving with a trailer.
- Distribute the load on the trailer so that the weight on the towing bracket follows the specified maximum towball load.
- Increase the tyre pressure to the recommended pressure for a full load. For tyre pressure decal location, see page 159.
- Clean the towbar regularly and grease the towball<sup>1</sup>.

<sup>1</sup> Does not apply to the towball if using a stabiliser hitch.

- Do not tow a heavy trailer when the car is brand new. Wait until it has been driven at least 1000 km.
- The brakes are loaded much more than usual on long and steep downhill slopes. Downshift to a lower gear and adjust your speed.
- The engine is loaded more heavily than usual when driving with a trailer.
- The engine and gearbox can overheat if the car is driven with a heavy load in hot weather. If the temperature gauge for the engine's cooling system goes into the red zone, stop and let the engine idle for a few minutes. The automatic gearbox responds through a built-in protection system. See the message on the information display. If the car overheats, the air conditioning may be switched off temporarily.
- In the interests of safety, speed should be restricted to 80 km/h, even if the laws of certain countries allow for higher speeds.
- Move the gear selector to parking position **P** when parking an automatic car with a hitched trailer. Always use the parking brake. Block the wheels with chocks when parking a car with hitched trailer on a hill.

**Trailer weights**

Information on permitted trailer weights, see page 234.

**WARNING**

Follow the stated recommendations for trailer weights. Otherwise, the car and trailer may be difficult to control in the event of sudden movement and braking.

**NOTE**

The stated maximum permitted trailer weights are those permitted by Volvo. National vehicle regulations can further limit trailer weights and speeds. Towbars can be certified for higher towing weights than the car can actually tow.



### Driving with a trailer

#### Automatic gearbox, driving with a trailer

##### Parking on a hill

- Apply the parking brake (handbrake).
- Move the gear selector to parking position **P**.

##### Starting on a hill

- Move the gear selector to driving position **D**.
- Release the parking brake (handbrake).

##### Steep inclines

- Select an appropriate manual gear position when climbing steep inclines or at low speeds. This prevents the gearbox from changing up and keeps the gearbox oil cooler.
- Do not use a higher manual gear than the engine can "handle". It is not always economical to drive in high gears.
- Avoid driving with a trailer on inclines of more than 15 %.

#### Diesel engine with manual gearbox, driving with a trailer

If the car is driven with a major load in a hot climate, the engine cooling fan can be replaced with one of a greater capacity than the standard model. Check with your nearest Volvo dealer regarding the options for your car.



## Towing equipment

### Towbars

The towball must be cleaned and greased regularly. If a towball hitch with vibration damper is used, it is not necessary to grease the towball.

If the car is equipped with a detachable towbar, the towball mounting instructions must be followed carefully, see page 145.

#### WARNING

Be sure to attach the trailer's safety cable to the correct place.

#### WARNING

If the car is fitted with a Volvo detachable towbar:

Follow the assembly instructions for the towball section carefully.

The towball section must be locked with the key before setting off.

Check that the indicator window shows green.

#### NOTE

Always take off the towball section after use. Keep it in the cargo area.

### Trailer cable

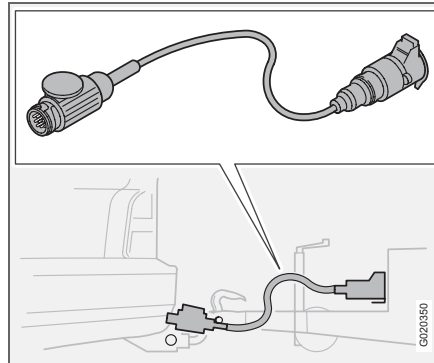

An adapter is required if the car's towbar has 13 pin electrics and the trailer has 7 pin electrics. Use an adapter cable approved by Volvo. Make sure the cable does not drag on the ground.





## Towing equipment

### Specifications

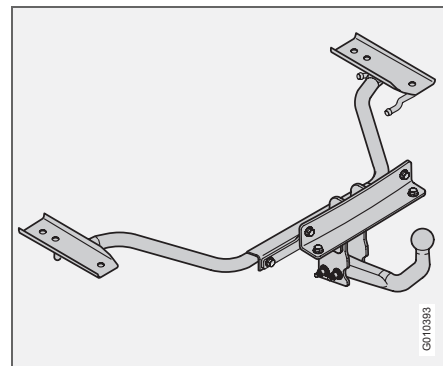
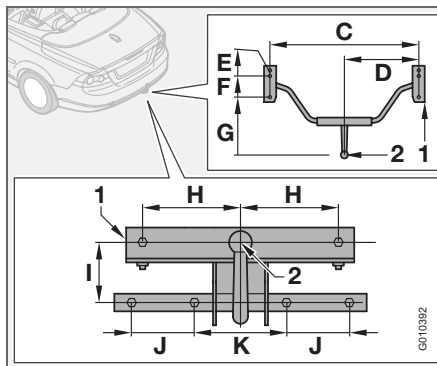
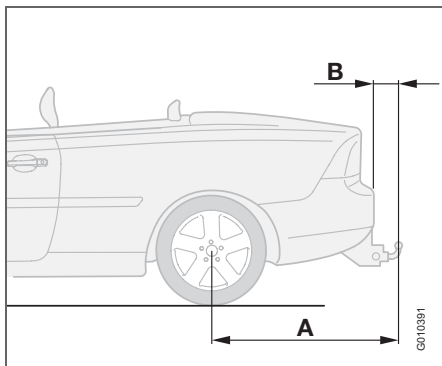

### Dimensions for mounting points (mm)

	A	B	C	D	E	F	G	H	I	J	K
Fixed or detachable towbar	1147	68	964	482	40	141	538	150	113	100	140
1	Side member										
2	Ball centre										

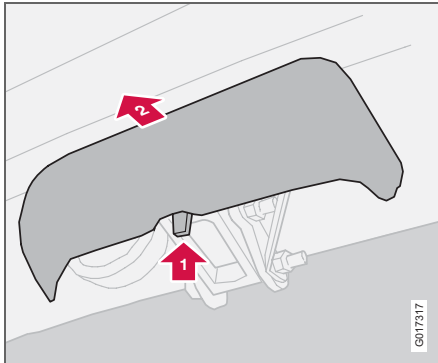
**Detachable towbar****Fitting the towball**

- Remove the protective cover.

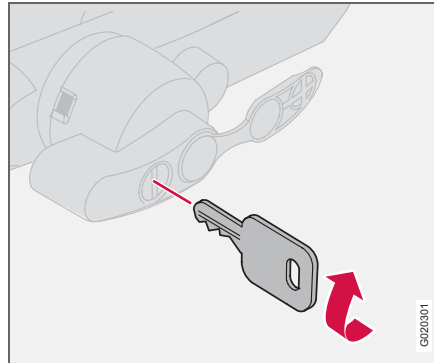

- Ensure that the mechanism is in the unlocked position by turning the key clockwise.

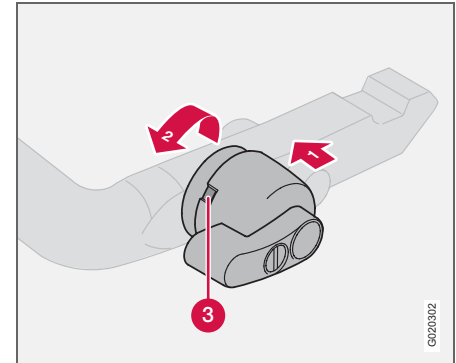

- Check that the indicator window (3) shows red. If the window does not show red, press in (1) and turn the locking wheel anticlockwise (2) until you hear a click.



### Detachable towbar

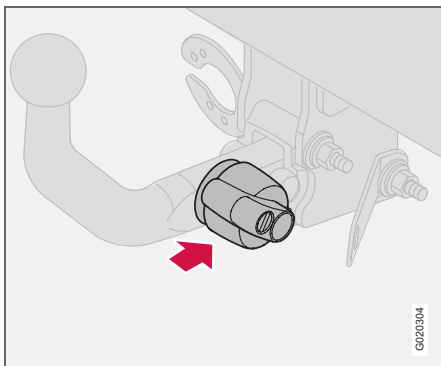

- Insert the towball section until you hear a click.

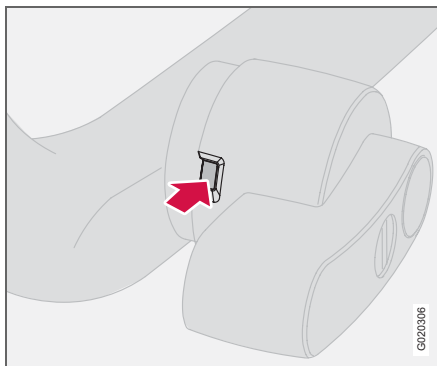

- Check that the indicator window shows green.

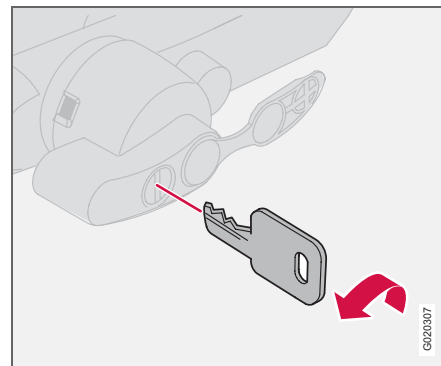

- Turn the key anticlockwise to the locked position. Remove the key from the lock.

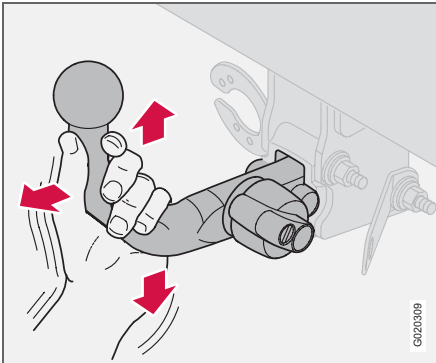

## Detachable towbar

**i** NOTE

Check that the towball section is secure by pulling it up, down and back. If the towball section is not fitted correctly then it must be removed and refitted in accordance with the previous steps.

**!** IMPORTANT

Only grease in the towball for the towing hitch, the remainder of the towball section should be clean and dry.

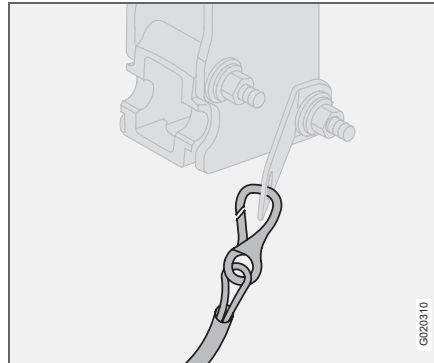
**i** NOTE

The trailer's safety cable must be secured in the towing bracket's mounting eye.



### Detachable towbar

#### Removing the towball

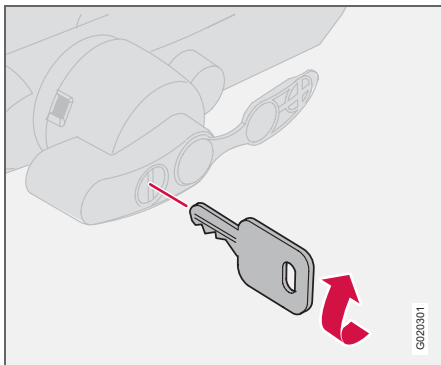

- Insert the key and turn it clockwise to the unlocked position.

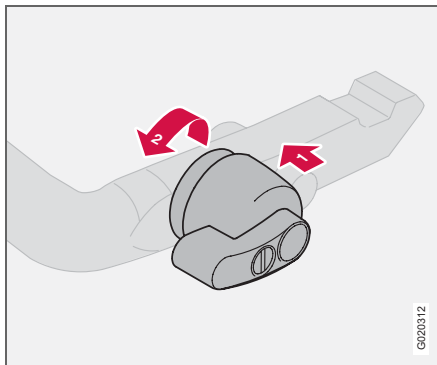

- Push in the locking wheel (1) and turn it anticlockwise (2) until you hear a click.

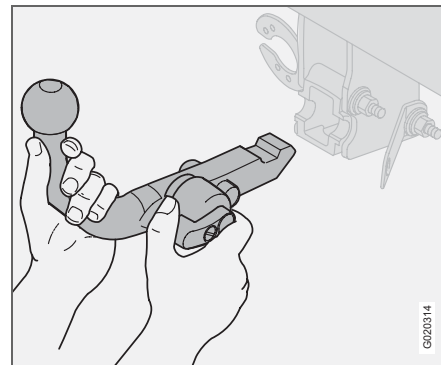

- Turn the locking wheel down fully, until it comes to a stop. Hold it in this position while pulling the towball rearward and upward.



#### WARNING

Firmly secure the towbar's loose towball if it is stored in the car's cargo area.

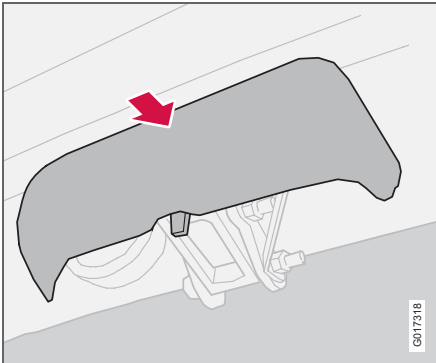
**Detachable towbar**

- Push on the protective cover.



## Loading

### General

The load capacity is affected by extra accessories mounted on the car, such as a towbar, the passengers' combined weight etc. as well as towball load. The load capacity of the car is reduced by the number of passengers and their weight. For information on permitted weights, see page 234.

#### WARNING

The car's driving characteristics change depending on how heavily it is loaded and how the load is distributed.

### Loading the cargo area

Stop the engine and apply the parking brake when loading or unloading long objects. The gear lever or gear selector could be knocked out of position by long loads, which could set the car in motion.

Place the load firmly against the backrest in front.

- Put wide loads in the centre.
- Heavy objects should be placed as low as possible.
- Cover sharp edges with something soft to avoid damaging the upholstery.

- Secure all loads to the load retaining eyelets with straps or web lashings.

#### WARNING

A loose object weighing 20 kg can, in a frontal collision at a speed of 50 km/h, carry the impact of an item weighing 1000 kg.

#### WARNING

Never load cargo above the backrest.

The protection provided by the inflatable curtain in the headlining may be compromised or eliminated by high loads.

Always secure the load. During heavy braking the load may otherwise shift, causing personal injury.

### Load carriers

To avoid damaging the car and for maximum possible safety while driving, it is recommended to use load carriers specially designed for your car by Volvo.

Carefully follow the installation instructions supplied with the carriers.

- Check periodically that the load carriers and load are properly secured. Lash the load securely with retaining straps.
- Distribute the load evenly over the load carriers. Put the heaviest objects at the bottom.
- The size of the area exposed to the wind, and therefore fuel consumption, increase with the load's size.
- Drive gently. Avoid quick accelerations, heavy braking and taking curves hard.

#### WARNING

The car's centre of gravity and driving characteristics are altered by roof loads.



## Adjusting headlamp pattern

### Correct light pattern for left or right-hand traffic

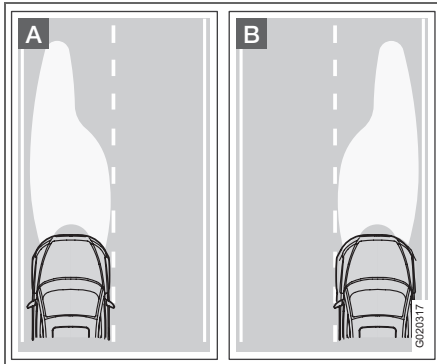

A. Headlamp pattern for left-hand traffic.  
B. Right-hand traffic.

The headlamps' projection can be adjusted to avoid dazzling other motorists. The correct pattern will also better illuminate the verge.

### Halogen headlamps

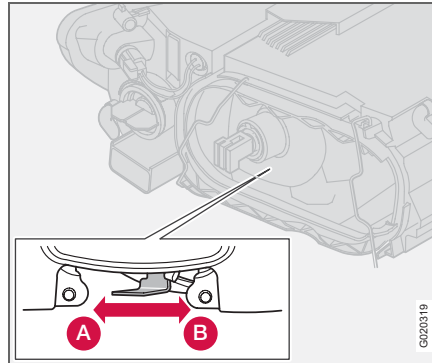

The headlamp control should be in position (A) for left-hand traffic and position (B) for right-hand traffic.

### Bi-Xenon headlamps

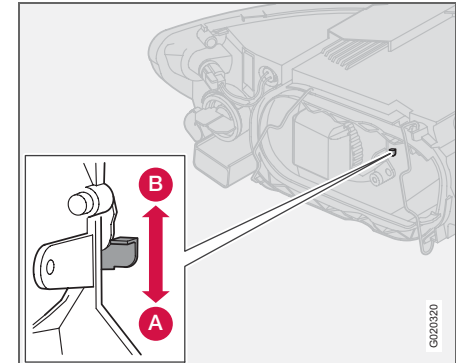

The headlamp control should be in position (A) for left-hand traffic and position (B) for right-hand traffic.

### **WARNING**

On cars with Bi-Xenon headlamps the replacement must be carried out by an authorised Volvo workshop. The headlamps must be handled with extreme care due to the high-voltage unit in the Xenon lamp.





General .....	154
Tyre pressure .....	158
Warning triangle and spare wheel .....	160
Changing wheels .....	162
Emergency puncture repair .....	164

## WHEELS AND TYRES



07



## General

### Driving characteristics and tyres

The tyres greatly affect the car's driving characteristics. The type of tyre, dimensions, tyre pressure and speed rating are important for how the car performs.

When changing tyres, ensure that tyres of the same type and dimensions, and preferably also the same make, are fitted to all four wheels. Follow the recommended tyre pressures specified on the tyre pressure label, see page 158.

### Designation of dimensions

The dimensions are stated on all car tyres. Example: 205/55R16 91 W.

205	Section width (mm)
55	Ratio between section height and width (%)
R	Radial ply
16	Rim diameter in inches (")
91	Tyre load index (in this case 615 kg)
W	Speed rating (in this case 270 km/h).

### Speed ratings

The car has "Whole Vehicle Type Approval", which means that dimensions and speed ratings must not differ from those specified on the vehicle's registration document. The only exception to these conditions is winter tyres (both those with metal studs and those without). If such a tyre is chosen, the car must not be driven faster than the speed rating of the tyre (for example, class Q can be driven at a maximum of 160 km/h).

Remember that traffic regulations determine how fast a car can be driven, not the speed class of the tyres.

Note! Maximum permitted speeds indicated.

Q	160 km/h (used only on winter tyres)
T	190 km/h
H	210 km/h
V	240 km/h
W	270 km/h
Y	300 km/h

### New tyres

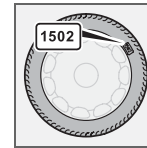

Tyres are perishable. After a few years they begin to harden at the same time as the friction capacity/characteristics gradually deteriorate. Therefore aim to get as

fresh tyres as possible when you replace them. This is especially important with regard to winter tyres. The week and year of manufacture, the tyre's DOT marking (Department of Transportation), are stated with four digits, for example 1502. The tyre in the illustration was manufactured in week 15 of 2002.

### Tyre age

All tyres older than six years should be checked by an expert even if they seem undamaged. The reason for this is that tyres age and decompose, even if they are hardly ever or never used. The function can therefore be affected due to the tyre's constituent materials being broken down. In such a case the tyre should then not be used. This also applies to spare tyres, winter tyres and tyres saved for future use. Examples of external signs which indicate that the tyre is unsuitable for use are cracks or discoloration.

The age of the tyre can be determined by the DOT marking, see illustration above.



### More even wear and maintenance

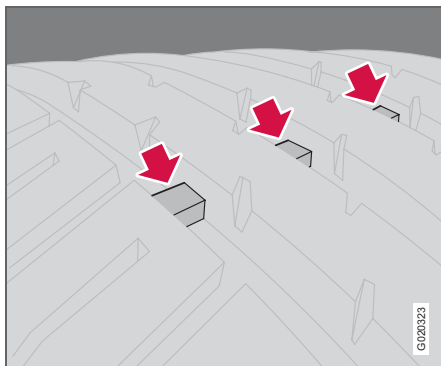

The correct tyre pressure results in more even wear, see page 159. To achieve the best traction and more even wear on the tyres, the regular switching of the front and rear tyres with each other is recommended. The first change should be after 5000 km and then at intervals of 10000 km, this is to avoid differences in tread depth. Tyres with the greatest tread depth should always be fitted to the rear wheels to decrease the risk of skidding. Contact an authorised Volvo workshop for an inspection if you are uncertain about tread depth.

Wheels should be stored lying down or hanging up, and not standing up.

### Tyres with tread wear indicators

Tread wear indicators are narrow treadless bands across the width of the tread. On the side of the tyre are the letters TWI (Tread Wear Indicator). When the tyre's tread depth is down to 1.6 mm, the tread depth will be level in height with the tread wear indicators. Change to new tyres as soon as possible. Remember that tyres with little tread depth provide very poor grip in rain and snow.

### Winter tyres

Volvo recommends winter tyres with particular dimensions. These are stated on the tyre pressure label, see page 158 for its location. The tyre dimensions are dependent on the engine variant. When driving on winter tyres, these must be fitted to all four wheels.

#### **i** NOTE

Ask a Volvo dealer which rim and tyre types are most suitable.

### Studded tyres

Studded winter tyres should be run in gently for 500–1000 km so the studs settle properly into the tyres. This gives the tyres, and especially the studs, a longer lifespan.

#### **i** NOTE

The legal provisions for the use of studded tyres vary from country to country.

### Tread depth

Road conditions with ice, slush and low temperatures place considerably higher demands on tyres than summer conditions. It is therefore not recommended to drive on winter tyres that have a tread depth of less than four millimetres.

### Snow chains

Snow chains may only be used on the front wheels. This also applies to all-wheel-drive cars.

Never drive faster than 50 km/h with snow chains. Avoid driving on bare ground as this wears out both the snow chains and tyres. Never use quick-fit snow chains as the space between the brake discs and the wheels is too small.

#### **!** IMPORTANT

Use Volvo genuine snow chains or equivalent chains designed for the car model, and tyre and rim dimensions. Consult an authorised Volvo workshop.



## General

### Rims and wheel nuts

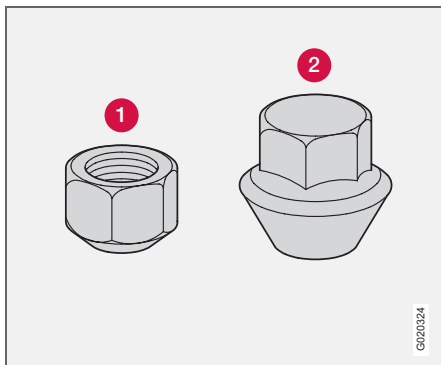

Standard (1) and bulge acorn (2) wheel nuts

Only use rims that are tested and approved by Volvo and which are Volvo genuine accessories. There are two types of wheel nut, depending on whether the rims are made of steel or aluminium. Tighten the wheel nuts to 130 Nm. Check the torque with a torque wrench.

#### **IMPORTANT**

The wheel nuts should be tightened to 130 Nm. Overtightening can damage the nuts and the bolts.

### Steel rims – standard wheel nuts (1)

Steel rims are normally mounted with the standard wheel nuts, but the bulge acorn variety may also be used.

#### **WARNING**

Never use standard nuts for aluminium rims. The wheels can come loose.

### Aluminium rims – bulge acorn wheel nuts (2)

Only use the bulge acorn variety of nuts with aluminium rims. These differ from other nut types as they have a rotating conical washer.

#### **NOTE**

These nuts may also be used with steel rims.

### Locking wheel nuts

Locking wheel nuts can be used on both aluminium and steel rims. If steel rims with locking nuts are used in combination with wheel covers, the locking wheel nut should be mounted on the bolt nearest the air valve. Otherwise the wheel cover cannot be fitted to the rim.

### Spare wheel Temporary Spare

The spare wheel<sup>1</sup> is only intended to be used for the short time it takes to get the normal wheel replaced or repaired. Replace the spare wheel as soon as possible with a normal wheel. The car's handling may be altered by the use of the spare wheel.

Never drive faster than 80 km/h with a spare wheel on the car.

#### **IMPORTANT**

The car must never be driven fitted with more than one "Temporary Spare" wheel.

<sup>1</sup> Certain variants and markets.



### Summer and winter wheels

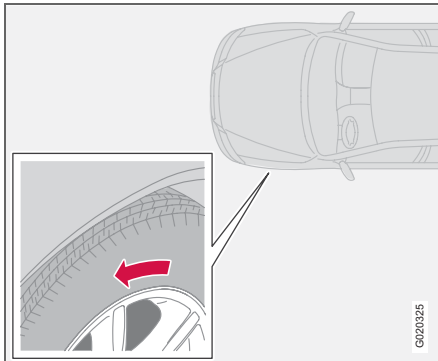

*The arrow shows the tyre's direction of rotation*

When summer and winter wheels are changed the wheels should be marked with which side of the car they were mounted on, for example **L** for left and **R** for right.

Tyres with a tread pattern which are designed to only turn in one direction have the direction of rotation marked with an arrow.

The tyre should always rotate in the same direction throughout its lifespan. Tyres should only be switched between front and rear positions, never between left and right-hand sides, or vice versa. If the tyres are

mounted incorrectly, the car's braking characteristics and capacity to force rain, snow and slush out of the way are adversely affected.

Tyres with the greatest tread depth should always be fitted to the rear of the car (to decrease the risk of skidding).

Wheels should be stored lying down or hanging up, and not standing up.

Contact an authorised Volvo workshop if you are uncertain about tread depth.

## Tyre pressure

### Recommended tyre pressure

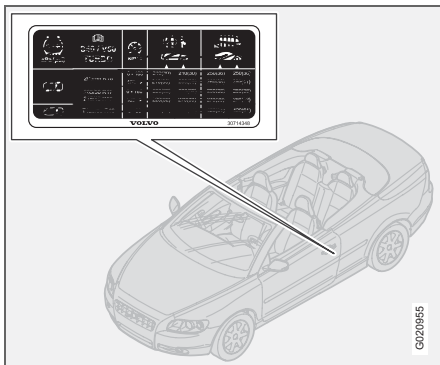

The tyre pressure label on the driver's side door pillar shows which pressures the tyres should have at different loads and speed conditions.

#### **i** NOTE

Full load in the car equates to the number of seats with seatbelts.

Stated on the decal:

- Tyre pressure for the car's recommended wheel size
- ECO pressure
- Spare wheel pressure (Temporary Spare).

### Checking the tyre pressure

Check the tyre pressure regularly.

#### **i** NOTE

Tyre pressure decreases over time, this is a natural phenomenon. Tyre pressure also varies depending on ambient temperature.

Even after several kilometres of driving the tyres warm up and the pressure increases, so air must not be released if the pressure is checked when the tyres are warm, while the pressure must be increased if it is too low. Inadequately inflated tyres increase fuel consumption, shorten tyre lifespan and impair the car's roadholding. Driving on tyres with tyre pressure that is too low could also result in the tyres overheating and disintegrating.

For information on the correct tyre pressure, refer to the tyre pressure table on page 159. The specified tyre pressures refer to "cold tyres". ("Cold tyres" means the tyres are the same temperature as the ambient temperature.)

### Fuel economy, ECO pressure

At speeds under 160 km/h, the general tyre pressure for full load is recommended in order to obtain optimum fuel economy.

Tyre pressure affects travelling comfort, road noise and steering characteristics.



Tyre pressure

## Tyre pressure table

Variant	Tyre size	Speed (km/h)	Load, 1-3 persons		Max. load	
			Front (kPa) <sup>1</sup>	Rear (kPa)	Front (kPa)	Rear (kPa)
2.4 2.4i	215/55 R16 91W	0-160	210	210	250	250
		160+	250	210	280	260
	215/50 R17 91W 235/45 R17 94W 235/40 R18 91Y	0-160	220	220	250	250
		160 +	260	220	280	260
T5	215/55 R16 91W	0-160	210	210	250	250
		160+	260	210	280	260
	215/50 R17 91W 235/45 R17 94W 235/40 R18 91 Y	0-160	220	220	250	250
		160+	270	220	290	270
D5	215/55 R16 91W	0-160	230	210	250	250
		160+	260	210	280	260
	215/50 R17 91W 235/45 R17 94W 235/40 R18 91 Y	0-160	240	220	250	250
		160+	270	220	290	270
All	All	0-160	250 <sup>2</sup>	250 <sup>2</sup>	250 <sup>2</sup>	250 <sup>2</sup>
Spare wheel <sup>3</sup>	T125/85R16 99M	0-80	420	420	420	420

<sup>1</sup>In certain countries there is the "bar" unit beside the SI unit "Pascal": 1 bar = 100 kPa

<sup>2</sup>ECO pressure page 158

<sup>3</sup>Temporary Spare





## Warning triangle and spare wheel

### Warning triangle

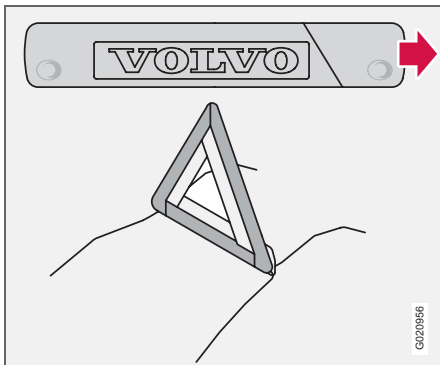

Follow the regulations for the use of a warning triangle<sup>1</sup>. Place the warning triangle in a suitable place with regard to the traffic.

- Undo the case containing the warning triangle, it is attached with Velcro. Take the warning foam triangle out of the case.
- Lower the warning triangle's support legs.

Ensure the warning triangle and its case are located in the spare wheel well.

### Spare wheel and jack

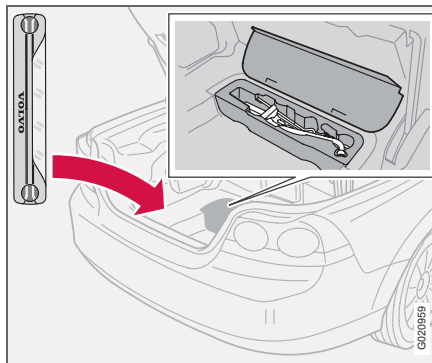

Location, tools for emergency puncture repair kit

### The car's original jack

The original jack should only be used for changing wheels. The jack's thread should always be well greased. Jack and crank are located in a foam block in the cargo area.

### Emergency puncture repair kit

For operation and location, see page 164.

<sup>1</sup> Certain markets.



## Warning triangle and spare wheel

### Spare wheel and tools

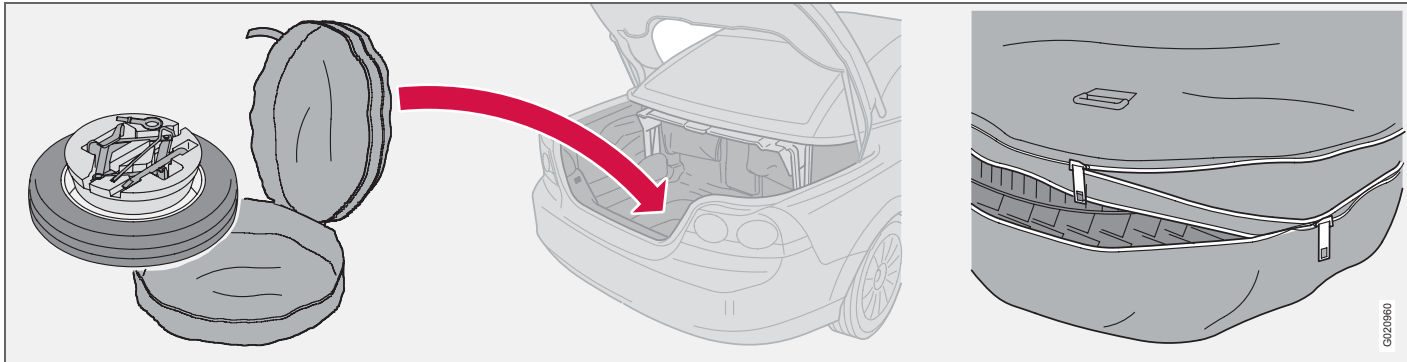

*Spare wheel and tools*

The spare wheel<sup>1</sup> is supplied in a tyre bag that is located in the cargo area's spare wheel well. In the centre of the tyre is a black foam block containing jack and wheel wrench. The tensioning strap for the bag is secured in two lashing eyes on the floor.

- Undo the two tensioning straps that secure the tyre bag to the floor.
- Unzip the tyre bag and take out the tools.
- Lift the spare wheel from the bag.

Place the damaged wheel in the tyre bag and strap it down with the tensioning straps. Be

sure to follow the instructions on the spare wheel bag when it is refitted.

<sup>1</sup> Option on certain markets



## Changing wheels

### Removing wheels

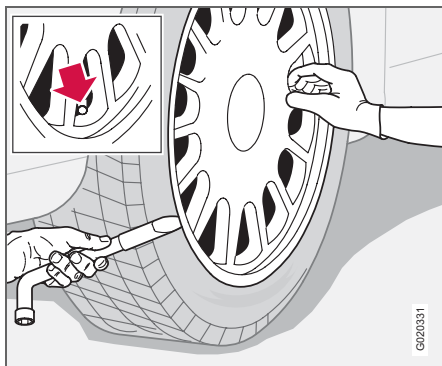

Set up the warning triangle if a wheel must be replaced at a busy location. Make sure that the car and jack are on a firm horizontal surface.

- Take out the spare wheel, jack and wheel wrench, which are found under the carpet in the cargo area.
- Apply the parking brake and engage first gear, or position **P** if the car has an automatic gearbox.
- Place chocks in front of and behind the wheels which will remain on the ground. Use heavy wooden blocks or large stones.

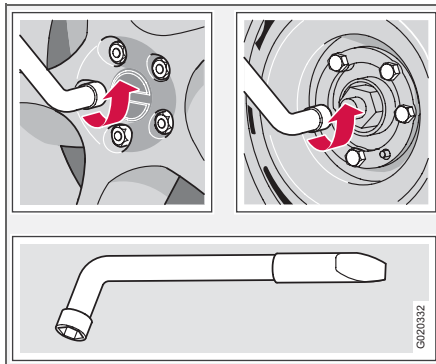

- Cars with steel rims have removable wheel covers. Prize off the wheel cover with the end of the wheel wrench, or pull it off by hand.
- Loosen the wheel nuts  $\frac{1}{2}$ -1 turn anticlockwise with the wheel wrench.

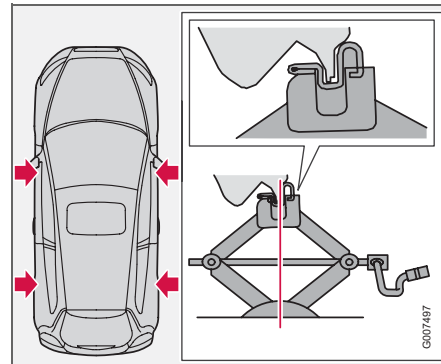

- Two jacking points are located on each side of the car. Wind down the jack's base so that it sits level on the ground. Check that the jack is seated correctly in the jacking point, as illustrated, and that the base is located directly under it.
- Jack up the car high enough that the wheel is clear of the ground. Remove the wheel nuts and lift off the wheel.



## Changing wheels

### Fitting the wheel

- Clean the contact surfaces on the wheel and hub.
- Put on the wheel. Tighten the wheel nuts.
- Lower the car so that the wheel cannot rotate.
- Tighten the wheel nuts crosswise. It is important that the wheel nuts are tightened properly. Tighten to 130 Nm. Check the torque with a torque wrench.
- Put on the wheel cover (steel rim).



### WARNING

Never crawl under the car when it is raised on the jack.

Passengers must leave the car when it is raised on the jack.

Ensure that passengers wait with the car - or preferably a crash barrier - between them and the road.



## Emergency puncture repair

### General

The emergency puncture repair kit is used to seal the puncture and to check and adjust the tyre pressure. It consists of a compressor and a bottle with sealing fluid. The kit works as a temporary repair. The sealing fluid bottle must be replaced before its expiration date and after use.

The sealing fluid effectively seals tyres punctured in the tread.



### NOTE

The emergency puncture repair kit is only intended for sealing tyres with a puncture in the tread.

The emergency puncture repair kit has limited capacity to seal tyres which have punctures in the wall. Do not seal tyres with the emergency puncture repair kit if they have larger slits, cracks or similar damage.

12 V sockets for the compressor are located by the centre console in the front, by the rear seat and in the cargo area. Choose the electrical socket that is nearest the punctured tyre.



### WARNING

You must not drive faster than 80 km/h after the emergency tyre repair kit has been used. Contact an authorised Volvo workshop for inspection of the sealed tyre (maximum driving distance is 200 km). The staff there can determine whether or not the tyre can be repaired or if it needs to be replaced.

### Location

The emergency puncture repair kit, with compressor and tools, is located in the tunnel for the ski compartment, see page 92.



## Emergency puncture repair

### Overview

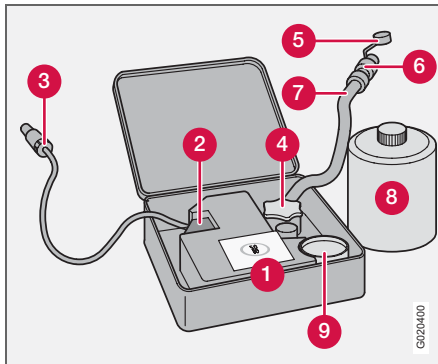

1. Decal, maximum permitted speed
2. Switch
3. Cable
4. Bottle holder (orange cap)
5. Protective cap
6. Pressure reducing valve
7. Air hose
8. Sealing fluid bottle
9. Pressure gauge

### Inflating the tyres

The car's original tyres can be inflated by the compressor.

- The compressor must be switched off. Make sure that the switch is in position **0** and locate the cable and air hose.
- Unscrew the wheel's dust cap and screw in the air hose valve connection to the bottom of the thread on the tyre's air valve.
- Connect the cable to one of the car's 12 V sockets and start the car.



### WARNING

Inhaling car exhaust fumes can result in danger to life. Never leave the engine running in enclosed areas or areas that lack sufficient ventilation.

- Start the compressor by flicking the switch to position **I**.
- Inflate the tyre to the pressure specified on the tyre pressure decal. (Release air using the pressure reducing valve if the tyre pressure is too high.)



### IMPORTANT

Risk of overheating. The compressor must not run for more than 10 minutes.

- Switch off the compressor. Detach the air hose and cable.
- Refit the valve's dust cap.



## Emergency puncture repair

### Sealing punctured tyres

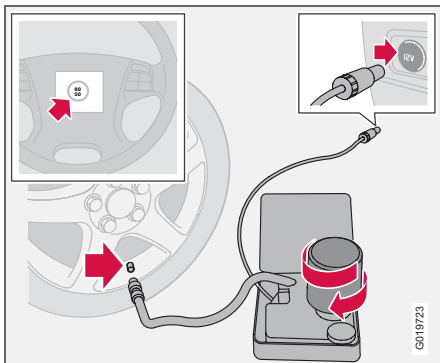

For information on the function of the parts, see the illustration on page 165.

- Open the lid of the emergency puncture repair kit.
- Detach the decal for maximum permitted speed and affix it to the steering wheel.
- Check that the switch is in position **0** and locate the cable and the air hose.

#### **WARNING**

The sealing fluid can irritate the skin. In the case of contact with skin, wash away the fluid with soap and water.

- Unscrew the orange cap and unscrew the bottle's stopper.

#### **NOTE**

Do not break the bottle seal. The seal is broken when the bottle is screwed in.

- Screw the bottle into its holder.

#### **WARNING**

Do not unscrew the bottle, it is equipped with a reverse catch to prevent leakage.

- Unscrew the wheel's dust cap and screw in the air hose valve connection to the bottom of the thread on the tyre's air valve.
- Plug the cable into the 12 V socket and start the car.
- Flick the switch to position **I**.

#### **WARNING**

Never stand next to the tyre when the compressor is running. If cracks or unevenness arise then the compressor must be switched off immediately. The journey should not be continued. Contact an authorised tyre centre.

#### **NOTE**

When the compressor starts, the pressure can increase up to 6 bar but the pressure drops after approximately 30 seconds.

- Inflate the tyre for 7 minutes.

#### **IMPORTANT**

Risk of overheating. The compressor must not run for more than 10 minutes.

- Switch off the compressor to check the pressure on the pressure gauge. Minimum pressure is 1.8 bar and maximum is 3.5 bar.

#### **WARNING**

If the pressure is below 1.8 bar then the hole in the tyre is too big. The journey should not be continued. Contact an authorised tyre centre.

- Switch off the compressor and unplug the cable from the 12 V socket.
- Detach the hose from the tyre's air valve and fit the valve's dust cap.
- As soon as possible, drive approximately 3 km at a maximum speed of 80 km/h so that the sealing fluid can seal the tyre.



## Emergency puncture repair

### Rechecking the repair and pressure

- Reconnect the equipment.
- Read the tyre pressure on the pressure gauge.
- If it is below 1.3 bar then the tyre is insufficiently sealed. The journey should not be continued. Contact a tyre centre.
- If the tyre pressure is higher than 1.3 bar, the tyre must be inflated to the pressure specified on the tyre pressure decal. Release air using the pressure reducing valve if the tyre pressure is too high.
- Switch off the compressor. Detach the air hose and cable. Refit the valve's dust cap.

### WARNING

Do not unscrew the bottle, it is equipped with a reverse catch to prevent leakage.

- Return the emergency puncture repair kit to the cargo area.

### NOTE

The sealing fluid bottle and hose must be replaced after use. Replacement must be performed by an authorised Volvo workshop.

### WARNING

Check the tyre pressure regularly.

- Drive to the nearest authorised Volvo workshop for the replacement/repair of the damaged tyre. Advise the workshop that the tyre contains sealing fluid.

### WARNING

You must not drive faster than 80 km/h after the emergency tyre repair kit has been used. Contact an authorised Volvo workshop for inspection of the sealed tyre (maximum driving distance is 200 km). The staff there can determine whether or not the tyre can be repaired or if it needs to be replaced.

### Changing the sealing fluid canister

Replace the bottle when the expiration date has passed. Treat the old bottle as environmentally hazardous waste.

### IMPORTANT

Read the safety instructions on the bottom of the bottle.





Cleaning .....	170
Touching up paintwork .....	173
Rustproofing .....	174

CAR CARE



08



## Cleaning

### Washing the car

Wash the car as soon as it becomes dirty. Use car shampoo. Dirt and road salt can lead to corrosion.

#### **IMPORTANT**

Avoid rinsing the car with the roof lowered, in order to avoid water entering the passenger compartment.

- Do not park the car in direct sunshine. Washing a car with hot paintwork can cause permanent paintwork damage. Wash the car in a car wash with waste water separator.
- Thoroughly rinse dirt off the underbody of the car.

#### **IMPORTANT**

Rinse the entire car to remove loose dirt. When using a pressure washer: make sure that the nozzle of the pressure washer is not closer than 30 cm to the bodywork. Do not spray directly at the locks, side windows or their sealing strip.

- Wash using a sponge, car shampoo and plenty of lukewarm water.
- If the dirt is difficult to dislodge, wash the car using a cold degreasing agent.

- Dry the car using a clean, soft chamois or a water scraper.
- Clean the wiper blades with a lukewarm soap solution or car shampoo.

### Removing bird droppings

Wash bird droppings off the paintwork as soon as possible. Bird droppings contain chemicals that affect and discolour paintwork very quickly. This discoloration can only be removed by a specialist.

#### **WARNING**

Always have the engine cleaned by a workshop. There is a risk of fire if the engine is hot.

#### **NOTE**

Outside lighting such as headlamps, fog lamps and rear lamps may temporarily have condensation on the inside of the lens. This is a natural phenomenon, all outside lighting is designed to withstand this. Condensation is normally vented out of the lamp when it has been switched on for a time.

### Automatic car washes

An automatic car wash is a simple and quick way of washing the car, but it can never replace a proper handwashing. The brushes

of an automatic car wash cannot reach everywhere.

#### **WARNING**

Always test the brakes after washing the car, including the parking brake, to ensure that moisture and corrosion do not attack the brake linings and reduce braking performance.

#### **IMPORTANT**

The roof must be closed for automatic car washes. The antenna by the boot lid should be unscrewed before automatic car washing.

#### **IMPORTANT**

Washing by hand is gentler to the paintwork than an automatic car wash. Paintwork is also more sensitive when it is new. For this reason, handwashing is recommended during the first few months with a new car.

Press the brake pedal lightly from time to time if driving for long periods in rain or slush. This heats and dries the brake pads. You should also do this when you begin driving in extremely damp or cold weather.



### Exterior plastic, rubber and trim components

A special cleaning agent available from Volvo dealers is recommended for cleaning coloured plastic parts, rubber and trim components (such as glossy trim mouldings). When using such a cleaning agent the instructions must be followed carefully.

#### IMPORTANT

Avoid waxing and polishing on plastic and rubber.

Polishing glossy trim mouldings could wear away or damage the glossy surface.

Polishing agent that contains abrasive must not be used.

### Electrically operated roof

If the roof is wet when opened then water will run into the passenger compartment. For this reason, wait until the water has run off before opening the roof.

### Hatch cover

The hatch cover (see page 80) is sensitive to water and should therefore be dried with a cloth if it becomes wet.

Clean with a slightly dampened rag.

### Polishing and waxing

Polish and wax the car if the paintwork is dull or to give the paintwork extra protection.

The car does not need to be polished until it is at least one year old. However, the car can be waxed during this time. Do not polish or wax the car in direct sunlight.

Wash and dry the car thoroughly before you begin polishing or waxing. Clean off asphalt and tar stains using Volvo tar remover or white spirit. More stubborn stains can be removed using fine rubbing paste designed for car paintwork.

Polish first with a polish and then wax with liquid or solid wax. Follow the instructions on the packaging carefully. Many preparations contain both polish and wax.

#### IMPORTANT

Paint treatment such as preserving, sealing, protection, lustre sealing or similar could damage the paintwork. Paintwork damage caused by such treatment is not covered by Volvo warranty.

### Cleaning the front side windows and door mirrors with water-repellent surface (option)

Never use products such as car wax, degreaser or similar on glass surfaces as this could ruin their water-repellent properties.

Take care when cleaning so as not to damage the glass surface.

To avoid damaging glass surfaces when removing ice – only use plastic ice scrapers.

There is natural wear of the water-repellent coating.

Treatment with a special finishing agent available from Volvo dealers is recommended in order to maintain the water-repellent properties. This should be used first after three years and then each year.



## Cleaning

### Cleaning the interior

#### Treating stains on fabric upholstery

A special cleaning agent, available from Volvo dealers, is recommended for cleaning the fabric upholstery. Other chemicals can impair the fire retardant qualities of the upholstery.

#### ! IMPORTANT

Sharp objects and Velcro may damage the fabric upholstery.

#### Treating stains on leather upholstery

Volvo leather upholstery is chromium-free and approved in accordance with the Öko-TEX 100 standard.

The leather is refined and processed so that it retains its natural characteristics. It is given a protective coating, but regular cleaning is required in order to maintain both characteristics and appearance. Volvo offers a comprehensive product for the cleaning and treatment of leather upholstery which, when used in accordance with the instructions, preserves the leather's protective coating.

After a period of use the natural appearance of the leather will nevertheless emerge, depending more or less on the surface tex-

ture of the leather. This is a natural maturing of the leather and shows that it is a natural product.

To achieve best results Volvo recommends cleaning and application of the protective cream once to four times per year (or more if required). Ask a Volvo dealer about Volvo's Leather care product.

#### ! IMPORTANT

Never use strong solvents. Such products may damage fabric, vinyl and leather upholstery.

#### ! IMPORTANT

Note that materials with colour that runs when dry (new jeans, suede garments etc.) may discolour the upholstery material.

#### Washing instructions for leather upholstery

- Pour the leather cleaner on the dampened sponge and squeeze out a strong foam.
- Work the dirt away with gentle circular movements.
- Dab with the sponge accurately on the stains. Allow the sponge to absorb the stain. Do not rub.

- Wipe off with soft paper or a cloth and allow the leather to dry completely.

#### Protective treatment of leather upholstery

- Pour a small amount of the protective cream on the felted cloth and massage in a thin layer of cream with gentle circular movements on the leather.
- Allow the leather to dry for 20 minutes before use.

The leather has now been given improved protection against stains and improved UV protection.

#### Treating stains on interior plastic, metal and wood parts

A special cleaning agent, available from Volvo dealers, is recommended for cleaning interior parts and surfaces. Do not scrape or rub stains. Never use strong stain removers.

#### Cleaning seatbelts

Use water and a synthetic detergent. A special textile cleaning agent is available from your Volvo dealer. Make sure the seatbelt is dry before allowing it to retract.



## Touching up paintwork

### Paintwork

Paint is an important part of the car's rust-proofing and should therefore be checked regularly. To avoid the onset of rust, damaged paintwork must be rectified immediately. The most common types of paintwork damage are stone chips, scratches, and marks on the edges of wings and doors.

### Colour code

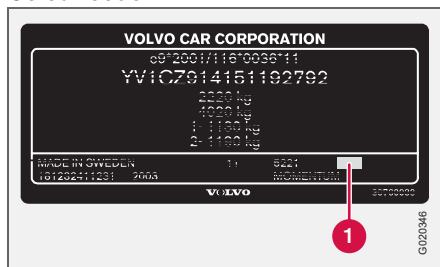

Data plate

It is important that the correct colour is used. The colour code number (1) is shown on the data plate, see page 232.

### Stone chips and scratches

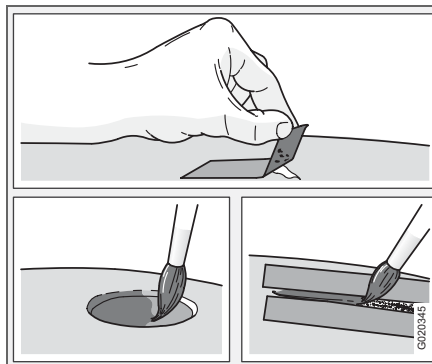

Before touching up paintwork, the car must be clean and dry and at a temperature above 15 C.

### Materials

- Primer in a can
- Paint in a can or touch-up pen
- Brush
- Masking tape

### Minor stone chips and scratches

If the stone chip has not penetrated to the bare metal and there is an undamaged colour coat, you can paint straight after cleaning the damaged area.

### If the stone chip has penetrated to the bare metal

- Stick a piece of masking tape over the damaged surface. Then remove the tape to remove any loose paint.
- Stir the primer well and apply using a fine brush or matchstick. Apply paint using a brush once the primer is dry.
- For scratches, proceed as above, but mask around the damaged area to protect the undamaged paintwork.
- After a few days, polish the touched-up areas. Use a soft rag and a small amount of lapping paste.



### Rustproofing

#### Inspection and maintenance

Your car received a thorough and complete rustproofing at the factory. Parts of the body are made of galvanised sheet metal. The underbody is protected by a wear-resistant anti-corrosion compound. And, a thin, penetrating rustproofing fluid was sprayed into the members, cavities and closed sections.

Maintain the car's rustproofing.

- Keep the car clean. Hose down the underbody. If using a pressure washer, keep the nozzle at least 30 cm from the painted surfaces.
- Regularly check and touch-up the rustproofing treatment as necessary.

The car's rustproofing does not normally require treatment for approximately 12 years. After that time, it should be treated at three-year intervals. If the car needs further treatment, please contact an authorised Volvo workshop.





Volvo service .....	178
Self-maintenance .....	179
Bonnet and engine compartment .....	180
Diesel .....	181
Oils and fluids .....	182
Wiper blades .....	187
Battery .....	188
Replacing bulbs .....	190
Fuses .....	196

## MAINTENANCE AND SERVICE

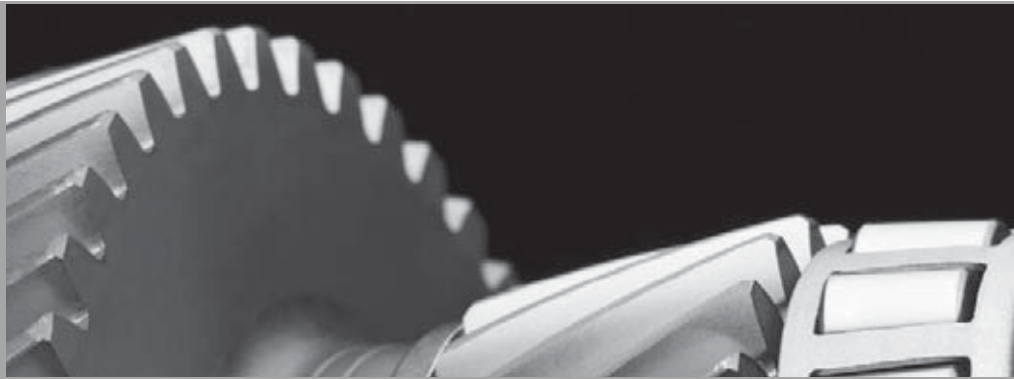

# 09



## Volvo service

### Volvo service programme

Before the car left the factory, it was thoroughly test driven. It was checked again in accordance with Volvo Car Corporation regulations before it was handed over to you.

To keep your Volvo as safe and reliable as possible, follow the Volvo service programme specified in the Service and Warranty Booklet. Have an authorised Volvo workshop carry out service and maintenance work. Volvo workshops have the personnel, special tools and service literature to guarantee the highest quality of service.



### IMPORTANT

For the Volvo warranty to apply, check and follow the instructions in the Service and Warranty Booklet.

### Special service measures

Certain service measures, which affect the car's electrical system, can only be performed using electronic equipment specially developed for your car. Always contact an authorised Volvo workshop before beginning or performing service work that affects the electrical system.

### Installing accessories

The incorrect connection and installation of accessories can negatively affect the car's electrical system. Certain accessories only function when the appropriate software has been programmed into the car's electrical system. Always contact an authorised Volvo workshop before installing accessories which are connected to or affect the electrical system.

### Recording vehicle data

One or more of the computers in your Volvo are capable of recording detailed information. This information is intended for use in research to enhance safety and for diagnosing faults in some of the in-car systems. The data may include details regarding seatbelt use by the driver and passengers, the functions of various vehicle systems and modules, and status information about the engine, throttle, steering, brakes and other systems. This data can also include details of the way the car is driven. This type of information can include, without being limited to, specific details such as vehicle speed, the use of the brake and accelerator pedals and steering wheel position. This latter type of data can be stored for a limited period while the car is being driven and subsequently during a collision or a near-collision. Volvo Car

Corporation will not disclose the stored information without consent. However, Volvo Car Corporation may be forced to disclose the information due to national legislation. Volvo Car Corporation and authorised Volvo workshops may also read and use the information.

### Adverse driving conditions

Check the oil level more frequently for long journeys:

- Towing a caravan or trailer
- In mountainous regions
- At high speeds
- In temperatures colder than  $-30\text{ }^{\circ}\text{C}$  or hotter than  $+40\text{ }^{\circ}\text{C}$ .

Also check the oil level more often if the car is often driven short distances (less than 10 km) when temperatures are low (below  $+5\text{ }^{\circ}\text{C}$ ).

This can produce abnormally high oil temperature or oil consumption.



## Before starting work on the car

### Battery

Check that the battery cables are correctly connected and tightened.

Never disconnect the battery when the engine is running (e.g. if replacing the battery).

Never use a quick charger to charge the battery. The battery cables must be disconnected when charging the battery.

The battery contains acid that is both corrosive and toxic. Handle the battery in an environmentally-suitable way. Let your Volvo dealer assist you.



### WARNING

High voltage output from the ignition system. The voltage in the ignition system is dangerous. The ignition must therefore always be switched off for work in the engine compartment.

Do not touch the spark plugs or ignition coils when the ignition is on or the engine is hot.

## Check regularly

Check the following at regular intervals, for example, when refuelling:

- Coolant – The level must be between the **MIN** and **MAX** marks on the expansion tank.
- Engine oil – The level must be between the **MIN** and **MAX** marks.
- Power steering fluid – The level must be between the **MIN** and **MAX** marks.
- Washer fluid – The reservoir should be well filled. Use washer antifreeze at temperatures around freezing.
- Brake and clutch fluid – The level must be between the **MIN** and **MAX** marks.



### WARNING

Bear in mind that the radiator fan may start automatically some time after the engine has been switched off.

Always have the engine cleaned by a workshop. There is a risk of fire if the engine is hot.



## Bonnet and engine compartment

### Opening the bonnet

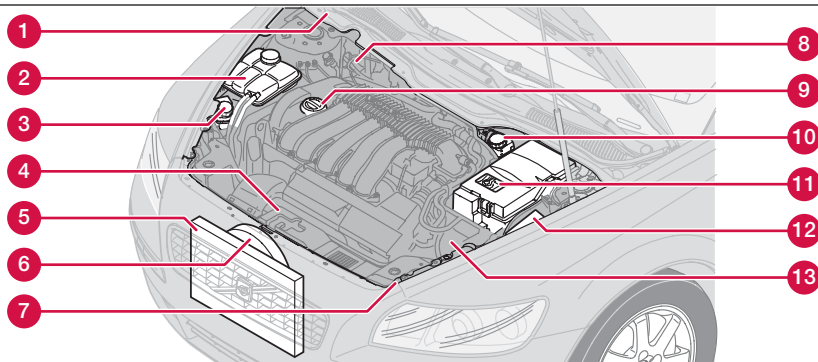
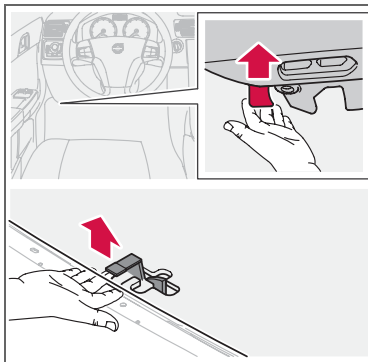

G010599

- Pull the handle on the far left under the dashboard. You will hear when the catch releases.
- Insert your hand under the centre of the front edge of the bonnet and press the safety catch to the right.
- Open the bonnet.



### WARNING

Check that the bonnet locks properly when closed.

### Engine compartment

- |   |  |
|---|--|
| 1. Washer fluid reservoir (4-cyl.)  | 8. Brake and clutch fluid reservoir (right-hand drive) |
| 2. Coolant expansion tank   | 9. Filler opening for engine oil <sup>1</sup>          |
| 3. Reservoir for the power steering fluid (concealed behind the headlamp) | 10. Brake and clutch fluid reservoir (left-hand drive) |
| 4. Engine oil dipstick <sup>1</sup>                                       | 11. Battery  |
| 5. Radiator   | 12. Relay and fuse box                                 |
| 6. Radiator fan   | 13. Air filter <sup>1</sup>                            |
| 7. Washer fluid reservoir (5-cyl.)  |  |

<sup>1</sup> Dependent on engine variant.



## Fuel system

Diesel must fulfil the EN 590 or JIS K2204 standards. Diesel engines are sensitive to contaminants, such as high volumes of sulphur particles for example. Only use diesel fuels from well-known producers. Never use diesel of dubious quality.

At low temperatures (–40 °C to –6 °C), a paraffin precipitate may form in the diesel fuel, which can lead to ignition problems. Special diesel fuel designed for low temperatures around freezing point is available from the major oil companies. This fuel is less viscous at low temperatures and reduces the risk of paraffin precipitate.

The risk of condensation in the fuel tank is reduced if the tank is kept well filled. When refuelling, check that the area around the fuel filler pipe is clean. Avoid spilling fuel onto the paintwork. Wash off any spillage with detergent and water.

### ! IMPORTANT

Only ever use fuel that fulfils the European diesel standard, see page 243.

### ! IMPORTANT

Diesel type fuels which must not be used: special additives, Marine Diesel Fuel, fuel oil, RME<sup>1</sup> (Rape Methyl Ester) and vegetable oil. These fuels do not fulfil the requirements in accordance with Volvo recommendations and generate increased wear and engine damage not covered by the Volvo warranty.

<sup>1</sup>Diesel fuel may contain a certain amount of RME, but further amounts must not be added.

### ! IMPORTANT

For model year 2006 or later the sulphur content must be a maximum of 50 ppm.

## Empty tank

No special procedures are required if the tank runs dry. The fuel system is bled automatically if the ignition switch is kept in position II for approx. 60 seconds before the start attempt.

## Draining condensation from the fuel filter

The fuel filter separates condensation from the fuel. Condensation can disrupt engine operation.

The fuel filter must be drained at the intervals specified in the Service and Warranty Booklet or if you suspect that the car has been filled with contaminated fuel.

### ! IMPORTANT

Certain special additives remove the water separation in the fuel filter.



## Oils and fluids

### Engine compartment decal for oil grade

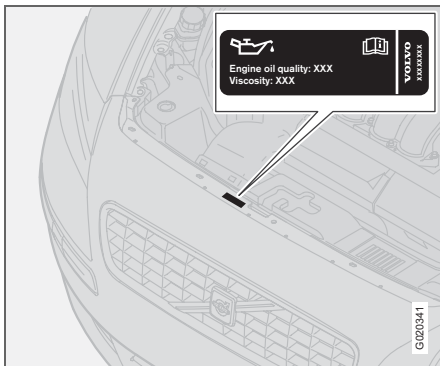

### ! IMPORTANT

Always use oil of the prescribed grade, see the engine compartment decal. Check the oil level frequently and change the oil regularly. The engine will be damaged if lower grade oil is used or if the car is driven with the oil level too low.

Using oil of a higher than specified grade is permitted. If the car is driven in adverse conditions, Volvo recommends using an oil of a higher grade than that specified on the decal. See page 237.

### Checking the engine oil and oil filter

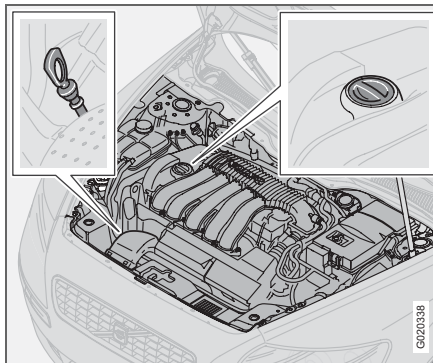

*Dipstick, petrol engines*

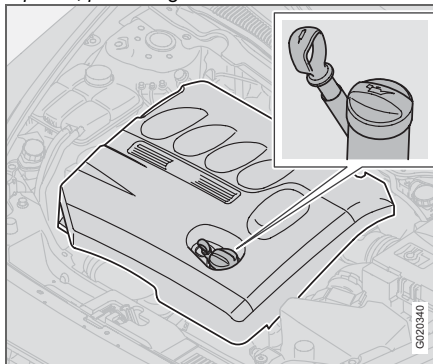

*Dipstick, diesel engines*

Volvo recommends Castrol oil products. Change the oil and replace the oil filter in accordance with the intervals specified in the Service and Warranty Booklet.

### ! IMPORTANT

In order to fulfil the requirements for the engine's service intervals all engines are filled with a specially adapted synthetic engine oil at the factory. The choice of oil has been made very carefully with regard to service life, starting characteristics, fuel consumption and environmental impact.

An approved engine oil must be used in order that the recommended service intervals can be applied. Only use a prescribed grade of oil (see the engine compartment decal) for both filling and oil change, otherwise you will risk affecting service life, starting characteristics, fuel consumption and environmental impact.

Volvo Car Corporation disclaims all warranty liability if engine oil of the prescribed grade and viscosity is not used.

Volvo uses different systems for warning of low oil level or low oil pressure. Certain variants have an oil pressure sensor, and then the lamp for oil pressure is used. Other variants have an oil level sensor, and then the driver is informed via the warning symbol in the centre of the instrument unit as well as by



display texts. Certain models have both variants. Contact an authorised Volvo dealer for more information.

Checking the oil level in a new car is especially important before the first scheduled oil change. The Service and Warranty Booklet specifies the odometer readings for oil changes.

Volvo recommends checking the oil level every 2 500 km. The most accurate measurements are made on a cold engine before starting. The measurement will be inaccurate if taken immediately after the engine is switched off. The dipstick will indicate that the level is too low because the oil has not had time to flow down into the oil sump.

### Checking the oil

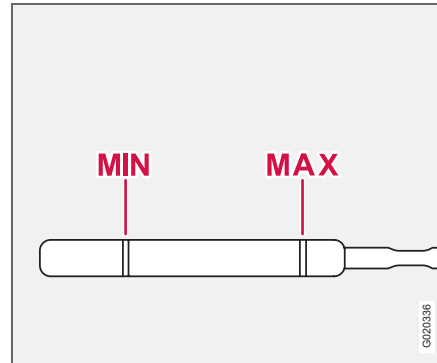

*The oil level must be within the area marked on the dipstick.*

#### Checking the oil in a cold engine:

- Wipe the dipstick clean before checking the level.
- Check the oil level using the dipstick. The oil level must be between the **MIN** and **MAX** marks.
- If the level is close to the **MIN** mark, start by topping up with 0.5 litres of oil. Top up until the oil level is nearer the **MAX** than the **MIN** mark on the dipstick. See page 237–238 for capacities.

#### Checking the oil in a warm engine:

- Park the car on a level surface, switch off the engine and wait 10–15 minutes to allow the oil time to run back to the sump.
- Wipe the dipstick clean before checking the level.
- Check the oil level using the dipstick. The oil level must be between the **MIN** and **MAX** marks.

If the level is close to the **MIN** mark, start by topping up with 0.5 litres of oil. Top up until the oil level is nearer the **MAX** than the **MIN** mark on the dipstick. See page 237–238 for capacities.



#### WARNING

Do not spill oil onto the hot exhaust manifold due to the risk of fire.



#### IMPORTANT

Never fill above the **MAX** mark. Oil consumption may increase if too much oil is poured into the engine.





## Oils and fluids

### Washer fluid, topping up

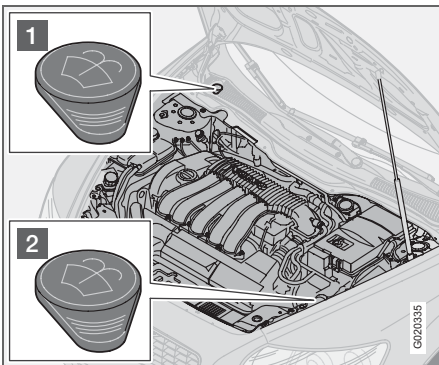

Location of washer fluid reservoir<sup>1</sup>.

The windscreen and headlamp washers share a common reservoir.

1. Filler cap on 4-cylinder engines and diesel.
2. Filler cap on 5-cylinder engines.

Add washer antifreeze during the winter so that the fluid does not freeze in the pump, reservoir and hoses. See the capacities on page 241.

<sup>1</sup> Dependent on engine variant.

**NOTE**  
Mix the washer antifreeze and water before filling the reservoir.

**TIP!** Clean the wiper blades when topping up washer fluid.

### Checking and topping up the coolant

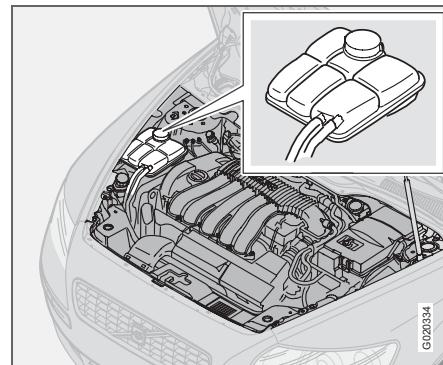

When topping up the coolant, follow the instructions on the packaging. It is important that the mixture of coolant concentrate and water is correct for the prevailing weather conditions. Never top up with water only. The risk of freezing increases with both too little and too much coolant concentrate.

**IMPORTANT**  
Always use coolant with anti-corrosion agent as recommended by Volvo. New cars are filled with coolant that can withstand temperatures down to approximately -35 C.

See capacities on page 241.



### Check the coolant regularly

The level should lie between the **MIN** and **MAX** marks on the expansion tank. If the system is not filled sufficiently, high local temperatures could occur, causing a risk of damage (cracks) in the cylinder head. Top up the coolant when the level falls to the **MIN** mark.

#### **WARNING**

The coolant may be very hot. If the coolant requires topping up when the engine is at operating temperature, unscrew the expansion tank cap slowly to gently release the overpressure.

#### **NOTE**

The engine must only be run with a well-filled cooling system. High temperatures can occur, causing a risk of damage (cracks) to the cylinder head.

### Checking and topping up the brake and clutch fluid

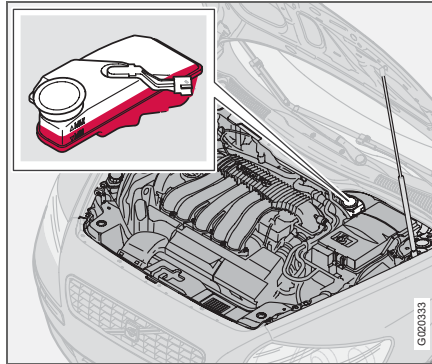

The brake and clutch fluid have a common reservoir<sup>1</sup>. The fluid level must be between the **MIN** and **MAX** marks. Check the level regularly. Change the brake fluid every other year or at every other regular service.

See the capacities and recommended fluid grade on page 241.

The fluid should be changed annually on cars driven in conditions requiring hard, frequent braking, such as driving in mountains or tropical climates with high humidity.

<sup>1</sup> Location dependent on whether car is left or right-hand drive.

#### **WARNING**

If the brake fluid is under the **MIN** level in the brake fluid reservoir, do not drive further before topping up the brake fluid.

The reason for the loss of brake fluid must be investigated.



### Oils and fluids

#### Checking and topping up the power steering fluid



#### NOTE

Check the level frequently.

The fluid does not require changing. For capacities and recommended fluid grade, see page 241.

If a fault should arise in the power steering system or if the car is without power and must be towed, it can still be steered. However the steering will be much heavier than normal and it will require more effort to turn the wheel.



## Changing the wiper blades

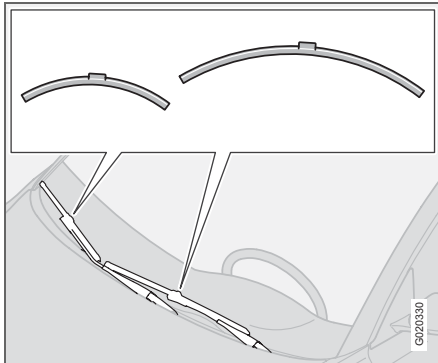

### **i** NOTE

The wiper blades are different lengths. The blade on the driver's side is longer than the blade on the passenger side.

- Turn up the wiper arm.
- Press the button located on the wiper blade mounting and pull straight out (1), parallel with the wiper arm.
- Slide in (2) the new wiper blade until a "click" is heard.
- Check (3) that the blade is firmly installed.
- Fold down the wiper arm.

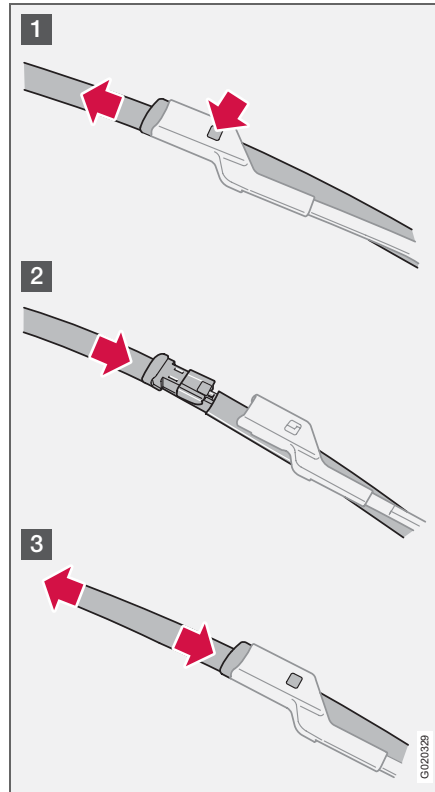



## Battery

### Battery care

The service life and function of the battery is influenced by factors such as the number of starts, discharging, driving style, driving conditions and climatic conditions.

#### NOTE

An expended battery must be recycled in an environmentally responsible manner as it contains lead.

#### WARNING

Batteries can generate oxyhydrogen gas, which is highly explosive. A spark, which can be generated if you connect the jump leads incorrectly, is sufficient to make the battery explode. The battery also contains sulphuric acid, which can cause serious burns. If the acid comes into contact with eyes, skin or clothing, flush with large quantities of water. If acid splashes into the eyes, seek medical advice immediately.

#### NOTE

The life of the battery is shortened if it becomes discharged repeatedly.

### Symbols on the battery

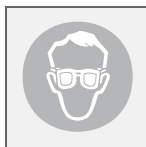

Use protective goggles.



Further information in the owner's manual.



Store the battery out of the reach of children.



The battery contains corrosive acid.



Avoid sparks and naked flames.



Risk of explosion.



## Changing the battery

### Removing the battery

- Switch off the ignition and remove the key.
- Wait at least 5 minutes before touching any electrical terminals. This allows time for the information in the car's electrical system to be stored in the various control modules.
- Remove the cover.
- Disconnect the negative battery lead.
- Disconnect the positive battery lead.
- Undo the front wall of the battery box using a screwdriver.
- Release the clamp securing the battery.
- Remove the battery.

### Fitting the battery

- Fit the battery into position.
- Fit the clamp securing the battery.
- Reinstall the front wall of the battery box.
- Connect the positive lead.
- Connect the negative lead.
- Refit the cover over the battery.



## Replacing bulbs

### General

All bulb specifications are given on page 246.

The following list contains bulbs and point-source lamps that are specialised or unsuitable for changing except at a workshop:

- General interior lighting in the roof
- Reading lamps and glovebox lighting
- Direction indicators, door mirror and approach lighting
- High-level brake light
- Bi-Xenon headlamp



### WARNING

On cars with Bi-Xenon headlamps, Xenon lamp replacement must be carried out by an authorised Volvo workshop. The headlamps must be handled with extreme care due to the high-voltage unit in the Xenon lamp.



### IMPORTANT

Never touch the bulbs' glass with your fingers. Grease and oils from your fingers are vaporised by the heat, coating and damaging the reflector.

### Changing front bulbs

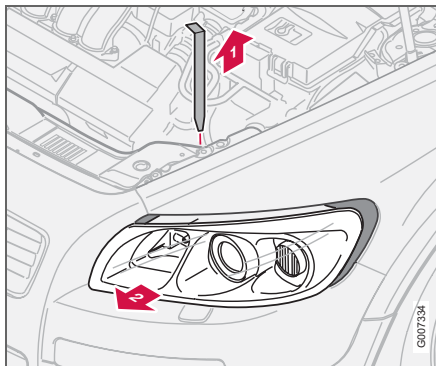

All front bulbs (except for fog lamps) are changed by first removing the lamp housing from the engine compartment.

#### Removing the lamp housing:

- Remove the ignition key and turn the light switch to position 0.
- Withdraw the lamp housing's locking pin (1).
- Pull the lamp housing to the side and then forward (2).



### IMPORTANT

Do not pull the electrical cable, only the connector.

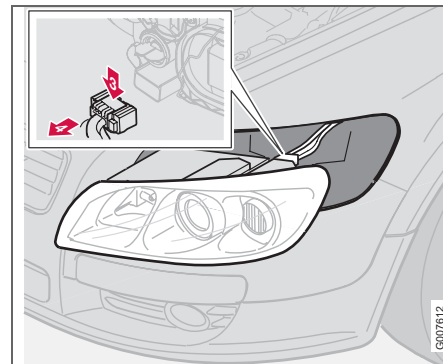

- Unplug the connector by pressing down the clip with a thumb (3) while moving out the connector (4) with the other hand.
- Lift out the lamp housing and place it on a soft surface to avoid scratching the lens.

#### Fitting the lamp housing:

- Plug in the connector and refit the lamp housing and locking pin. Check that the pin is correctly inserted.
- Check the lighting.

The lamp housing must be plugged in and secured in place before the lighting is turned on or the ignition key inserted into the ignition switch.



## Replacing bulbs

09

## Dipped beam

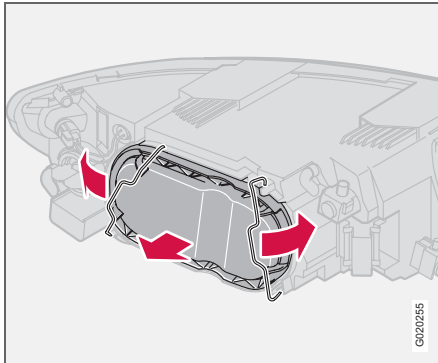
**Removing the cover and bulb:**

- Remove the entire lamp housing.
- Bend aside the catches and remove the cover.
- Unplug the connector from the bulb.
- Release the spring clip that secures the bulb. First, press it to the left to release it, then out and down.
- Pull out the bulb.
- Refit the lamp housing.

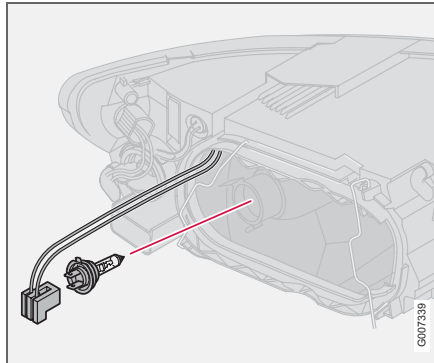
**Fitting a new bulb**

- Fit the new bulb. It can only be fitted in one position.
- Press the spring clip up and then slightly to the right so that it clicks into place.
- Press the connector back on.
- Refit the plastic cover.
- Refit the lamp housing.

## Main beam

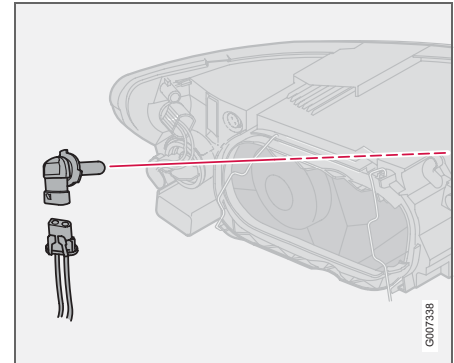

- Remove the entire lamp housing.
- Left-hand headlamp:  
Turn the bulb holder anticlockwise.
- Right-hand headlamp:  
Turn the bulb holder clockwise.
- Withdraw the bulb holder and change the bulb.
- Refit the bulb holder. It can only be fitted in one way.
- Refit the lamp housing.





## Replacing bulbs

### Position/parking lamps

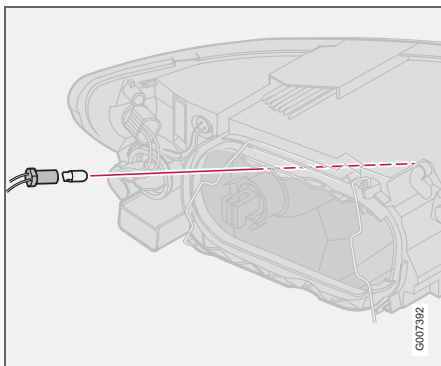

- Pull out the bulb holder with a pair of pliers. Do not pull out the bulb holder by pulling the electrical cable.
- Replace the bulb.
- Press the bulb holder back into place. It can only be fitted in one way.

### Direction indicators

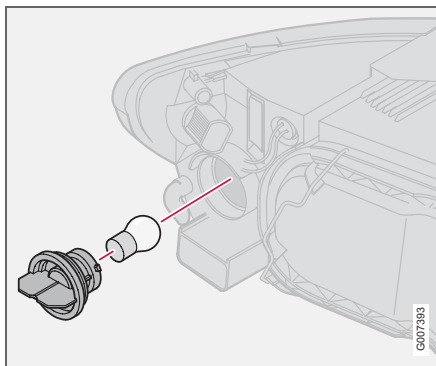

- Twist the bulb holder anticlockwise and remove it.
- To remove the bulb from the bulb holder, press the bulb in and turn it anticlockwise.
- Fit a new bulb and refit the bulb holder into the lamp housing.

### Side marker lamps

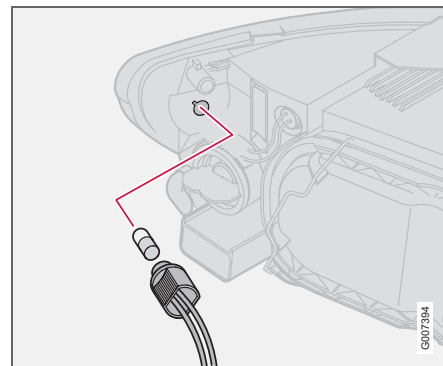

- Twist the bulb holder anticlockwise and withdraw it. Replace the bulb.
- Refit the bulb holder. It can only be fitted in one way.



## Replacing bulbs

## Fog lamps

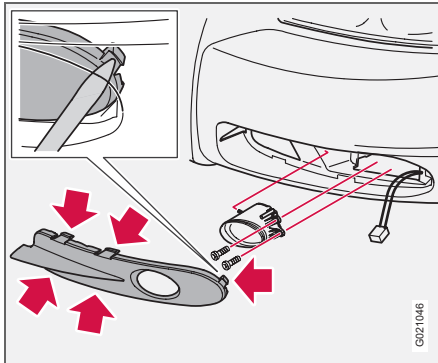

- Switch off all lights and turn the ignition key to position 0.
- Remove the panel from around the lamp housing.
- Remove the two Torx screws securing the lamp housing and take out the lamp housing.
- Unplug the connector from the bulb.
- Turn the bulb anticlockwise and pull it out.
- Fit the new bulb and turn it clockwise.
- Plug in the connector to the bulb.
- Secure the lamp housing with the screws and press the panel back into place.

## Removing the bulb holder

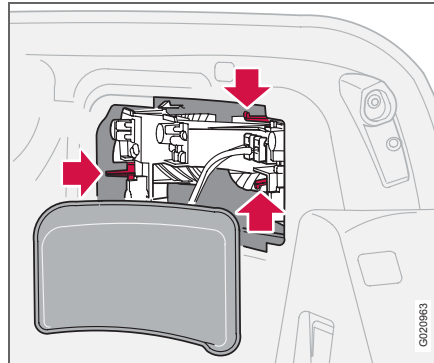

All bulbs in the rear lamp cluster can be replaced from inside the cargo area. Switch off all lights and turn the ignition key to position 0.

**NOTE**

If the error message **BULB FAILURE/ CHECK STOP LAMP** remains after a faulty bulb has been replaced then consult an authorised Volvo workshop.

## Location of the bulbs in the rear lamp cluster

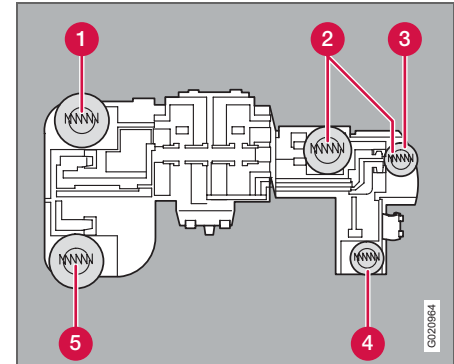
*Bulb holder*

1. Brake light
2. Position/parking lamps
3. Rear fog lamp (one side)

**NOTE**

The rear fog lamp bulb is only used in one of the rear light clusters. In the left-hand rear light cluster on left-hand drive cars, and in the right-hand rear light cluster on right-hand drive cars.

4. Direction indicators
5. Reversing lamp



## Replacing bulbs

### Number plate lighting

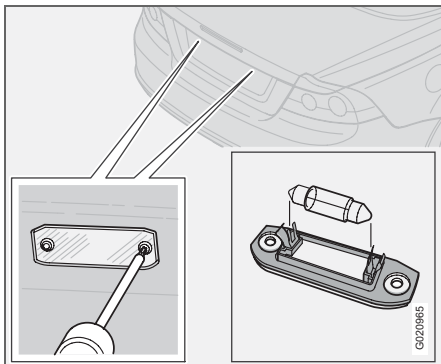

- Switch off all lights and turn the ignition key to position **0**.
- Remove the screws with a screwdriver.
- Detach the lens carefully.
- Replace the bulb.
- Refit and screw in the lens.

### Courtesy lighting

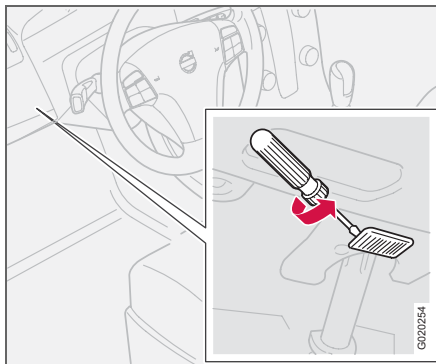

- There is courtesy lighting under the dashboard on the driver and passenger sides.
- Insert a screwdriver and gently turn so that the lens detaches.
- Remove the blown bulb.
- Fit a new bulb.
- Refit the lens.

### Cargo area

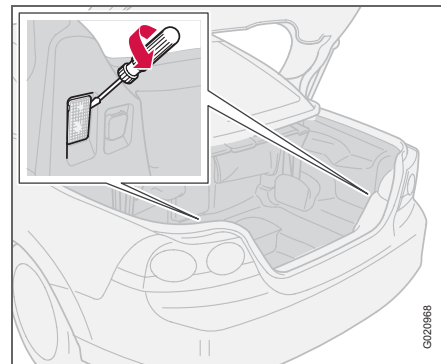

- Insert a screwdriver and gently turn so that the lamp housing comes loose.
- Remove the blown bulb and fit a new one.



## Replacing bulbs

### Vanity mirror lighting

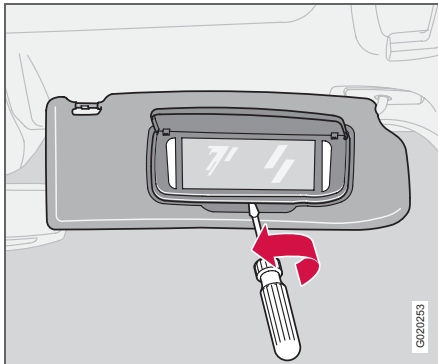

#### Removing the mirror glass:

- Insert a screwdriver underneath the lower edge, in the centre. Carefully prise up the lug on the edge.
- Insert the screwdriver under the edge on both the left and right side (at the black rubber points) and carefully prise so that the lens releases at the lower edge.
- Carefully detach and lift aside the entire mirror glass and cover.
- Remove the blown bulb and replace it with a new one.

#### Fitting the mirror glass:

- First, press the three lugs at top edge of mirror glass back into position.
- Then press the three lower lugs back into position.

### Interior lighting, rear

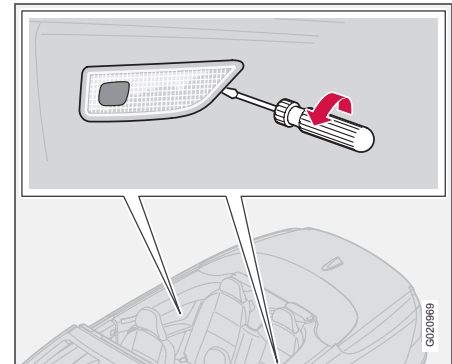

- Insert a screwdriver and gently turn so that the lamp housing comes loose.
- Remove the blown bulb and fit a new one.



## Fuses

### General

All electrical functions and components are fused to protect the car's electrical system from damage by short circuiting and overloading.

The fuses are in two different locations in the car:

- Relay/fuse box in the engine compartment
- Relay/fuse box in the passenger compartment.

### Changing

If an electrical component or function does not work, it may be because the component's fuse was temporarily overloaded and blew.

- Look in the fuse diagram to locate the fuse.
- Pull out the fuse and check from the side to see whether the curved wire has blown.
- If this is the case, replace it with a new fuse of the same colour and amperage.

Each fuse box has space for several spare fuses. If the same fuse blows repeatedly it means that there is a fault in the component. Contact an authorised Volvo workshop to have the system checked.



## Relay/fuse box in the engine compartment

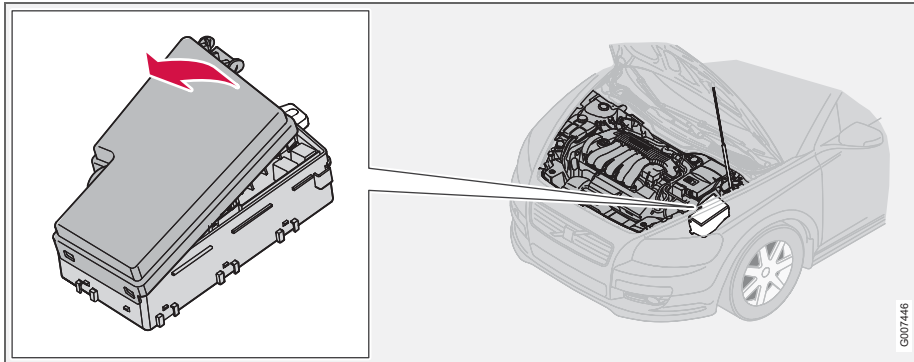

The fuse box has 36 fuse positions. Be sure to replace a blown fuse with a new fuse of the same colour and amperage.

- 19—36 are of the "Mini Fuse" type.
- Fuses 7—18 are of the "JCASE" type and should be replaced by an authorised Volvo workshop.
- Fuses 1—6 are of the "Midi Fuse" type and may only be replaced by an authorised Volvo workshop.

On the inside of the cover are tweezers to assist removing and fitting fuses.



## Fuses

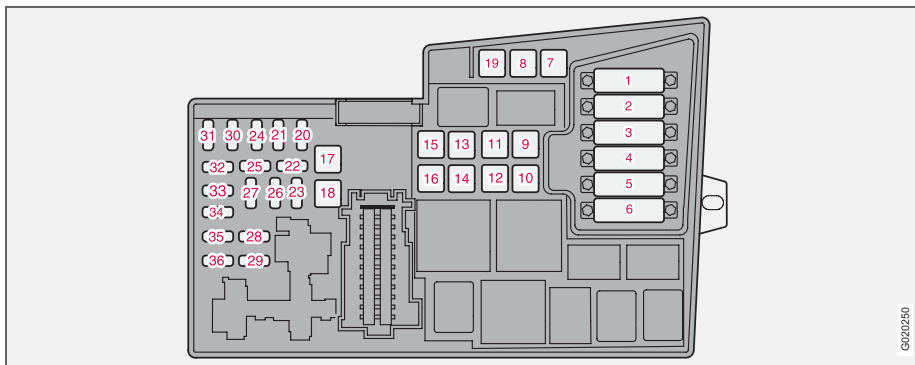

1. Radiator fan .....	50 A	13. Starter motor relay .....	30 A
2. Power steering .....	80 A	14. Trailer wiring .....	40 A
3. Supply to passenger compartment fuse box .....	60 A	15. Power roof .....	30 A
4. Supply to passenger compartment fuse box .....	60 A	16. Supply to infotainment system .....	30 A
5. Climate control element, additional heater PTC (option) .....	80 A	17. Windscreen wipers .....	30 A
6. Glow plugs (diesel) .....	70 A	18. Supply to passenger compartment fuse box .....	40 A
7. ABS pump .....	30 A	19. Reserve .....	-
8. ABS valves .....	20 A	20. Horn .....	15 A
9. Engine functions .....	30 A	21. Fuel-driven additional heater, passenger compartment heater .....	20 A
10. Ventilation fan .....	40 A	22. Subwoofer .....	25 A
11. Headlamp washers, power roof, lockable storage compartment and ski hatch .....	20 A	23. Engine control module ECM (5-cyl. petrol)/ Transmission control module (TCM) .....	10 A
12. Supply to heated rear window .....	30 A	24. Heated fuel filter, PTC element oil trap (diesel) .....	20 A



## Fuses

09

25. Reserve .....	-
26. Ignition switch .....	15 A
27. A/C compressor .....	10 A
28. Reserve .....	-
29. Front fog lamp .....	15 A
30. Engine control module ECM (4-cyl. diesel) .....	3 A
31. Reserve .....	-
32. Injectors (petrol), mass air flow sensor and turbo control (diesel) .....	10 A
33. Lambda-sond, vacuum pump (petrol), engine control module ECM (diesel) .....	20 A
34. Pressure switch, climate control system, ignition coils (petrol), glow plugs and EGR emission control (diesel) .....	10 A
35. Engine sensors for valves, relay coil, air conditioning PTC element, oil trap (petrol), engine control module ECM (diesel), canister (petrol), MAF mass air flow sensor (petrol) .....	15 A
36. Engine control module ECM (not diesel), accelerator pedal position sensor, lambda-sond (diesel) .....	10 A





## Fuses

### Relay/fuse box in the passenger compartment

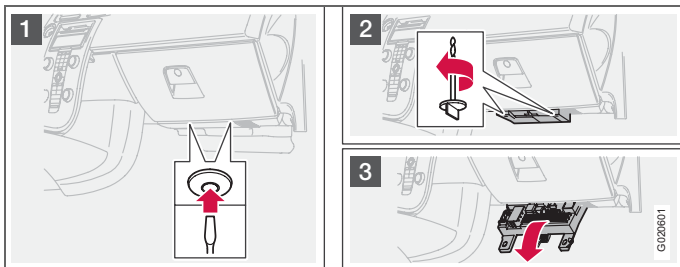

The fuse box has 50 fuse positions. The fuses are located under the glovebox. The box also provides space for several spare fuses. Tools for fuse replacement are located in the relay/fuse box in the engine compartment, see page 197.

#### Changing fuses

- Remove the trim concealing the fuse box by pressing in the pin in the centre of the clips (1) about one cm and then withdrawing the clips.
- Turn the two wing screws (that secure the fuse box) (2) anticlockwise so that they detach.
- Lower the fuse box (3) half way. Pull it towards the seat until it stops. Lower it

completely. The fuse box can be unhooked.

- Close the fuse box in the reverse order.
- Remove the pins from the centre of the clips. Fit the trim and the clips, and reinsert the loose pins into the clips, this expands the clips and secures the trim.

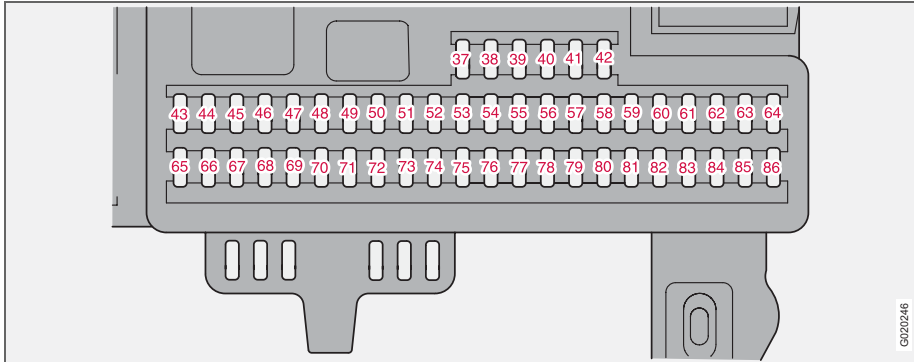

37. Reserve .....	-	49. SRS system .....	10 A
38. Reserve .....	-	50. Reserve .....	-
39. Reserve .....	-	51. Additional heater for the passenger compartment, fuel filter relay, heating .....	10 A
40. Reserve .....	-	52. Transmission control module (TCM), ABS system .....	5 A
41. Reserve .....	-	53. Power steering .....	10 A
42. Reserve .....	-	54. Parking assistance, Bi-Xenon (option) .....	10 A
43. Phone, audio system, RTI (option) .....	15 A	55. Keyless drive control module .....	20 A
44. SRS system, engine control module ECM (5-cyl.) .....	10 A	56. Remote control module, siren control module .....	10 A
45. Electrical socket, passenger compartment .....	15 A	57. Data link connector (DLC), brake light switch .....	15 A
46. Passenger compartment, glovebox and courtesy lighting ....	5 A	58. Main beam right, auxiliary lamps relay coil .....	7,5 A
47. Interior lighting .....	5 A	59. Main beam, left .....	7,5 A
48. Washer .....	15 A		



## Fuses

60. Seat heating (driver's side).....	15 A	84. Power passenger seat.....	25 A
61. Seat heating (passenger side).....	15 A	85. Power driver's seat .....	25 A
62. Reserve .....	-	86. Interior lighting, cargo area lighting, power seats .....	5 A
63. Supply, power window, right rear.....	20 A		
64. Lamp for door lock, RTI .....	5 A		
65. Infotainment system .....	5 A		
66. Infotainment control module (ICM), climate control .....	10 A		
67. Reserve .....	-		
68. Cruise control .....	5 A		
69. Climate control, rain sensor, BLIS button .....	5 A		
70. Reserve .....	-		
71. Reserve .....	-		
72. Reserve .....	-		
73. Overhead console for interior lighting (OHC), rear seatbelt reminder .....	5 A		
74. Fuel pump relay .....	15 A		
75. Reserve .....	-		
76. Reserve .....	-		
77. Electrical socket in cargo area, accessory electronic module (AEM) .....	15 A		
78. Reserve .....	-		
79. Reversing lamp .....	5 A		
80. Reserve .....	-		
81. Supply, power window, left rear .....	20 A		
82. Supply, power window and door, right front.....	25 A		
83. Supply, power window and door, left front.....	25 A		



[Empty rectangular box]

09

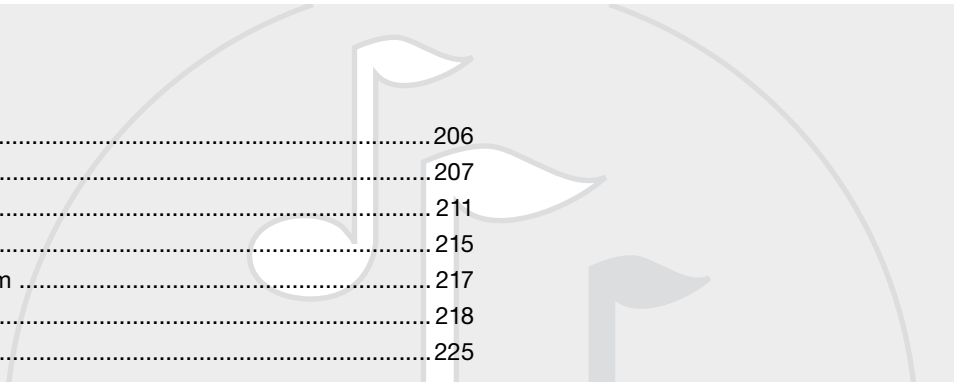

General .....	206
Audio functions .....	207
Radio functions .....	211
CD functions .....	215
Menu structure – audio system .....	217
Phone functions (option) .....	218
Menu structure – phone .....	225

## INFOTAINMENT SYSTEM



# 10



# 10 Infotainment system

## General

### Infotainment system

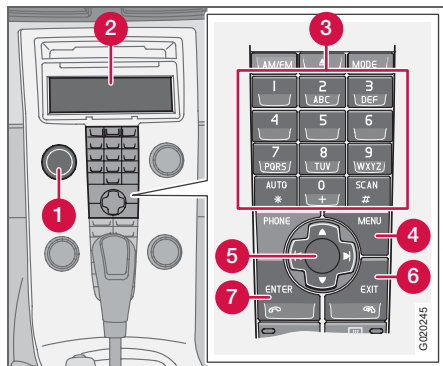

Infotainment is a system that integrates the audio system and the phone<sup>1</sup>. The infotainment system can be easily operated using the control panel or the steering wheel keypad<sup>1</sup>, see page 53. The display (2) shows messages and information on the current function.

### Audio system

#### On/Off

**POWER** (1) switches the audio system on or off. If the audio system is active when the ignition key is turned to position **0** it contin-

<sup>1</sup> Option

ues to be active until the key is removed from the ignition switch. The audio system is then started automatically the next time the key is turned to position **I**.

### Menus

Some infotainment system functions are controlled via a menu system. The current menu level is shown at the top right of the display. Menu options are shown in the middle of the display.

- **MENU** (4) leads to the menu system.
- Up/down with the navigation button (5) moves between menu options.
- **ENTER** (7) selects or activates/deactivates a menu option.
- **EXIT** (6) goes back one step in the menu structure. A long press on **EXIT** will exit the menu system.

### Shortcuts

Menu options are numbered and can also be selected directly with the keypad (3).

### Equipment

The audio system can be equipped with different options and different versions. There are three audio system versions: Performance, High Performance and Premium Sound. FM and AM radio with RDS and CD player is however included in each version.

### Dolby Surround Pro Logic II

Dolby Surround Pro Logic II<sup>2</sup> distributes the two stereo audio channels to left, centre, right and rear speakers. This provides a more realistic sound quality than that provided by standard two-channel stereo.



Dolby Surround Pro Logic II and the Dolby icon are trademarks of Dolby Laboratories Licensing Corporation.

The Dolby Surround Pro Logic II System is manufactured under license from Dolby Laboratories Licensing Corporation.

<sup>2</sup> Premium Sound



## Audio functions

### Audio controls

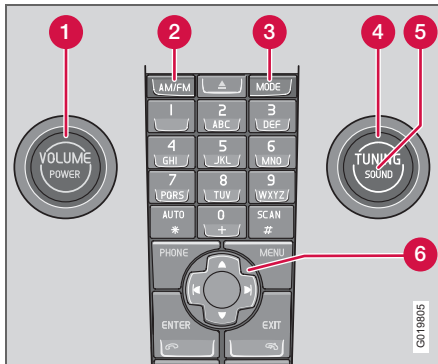

1. **VOLUME** – Knob
2. **AM/FM** – Audio source selection
3. **MODE** – Audio source selection, CD/AUX
4. **TUNING** – Knob
5. **SOUND** – Button

### Volume

Use **VOLUME** (1) or the steering wheel key-pad to regulate the volume, see page 53. Audio volume adjusts automatically depending on vehicle speed, see page 209.

### Audio source selection

Repeatedly pressing **AM/FM** switches between **FM1**, **FM2** and **AM**. Repeatedly pressing **MODE** switches between **CD** and **AUX**.

### AUX

The AUX input can be used for connecting an MP3 player for example.

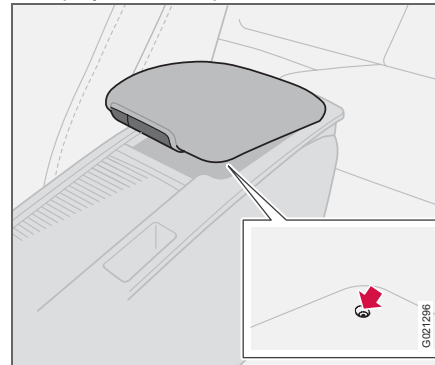

Input for external audio source (AUX) 3.5 mm

### NOTE

The sound quality may be impaired if the player is charged while the audio system is in AUX mode, so avoid charging the player.

Sometimes the AUX external audio source can be heard at a different volume to the internal audio sources, e.g. the CD player. If the audio volume of the external audio source is too high then the sound quality can be impaired. Prevent this by adjusting the input volume of the AUX input.

- Set the audio system in AUX mode using **MODE**.
- Press **MENU** and then **ENTER**.
- Scroll to **AUX input Volume** and press **ENTER**.
- Turn **TUNING** or press right/left on the navigation button.





# 10 Infotainment system

## Audio functions

### USB/iPod contact<sup>1</sup>

It is possible to connect an iPod and/or USB memory for example to the car's infotainment system via the contact in the centre console.

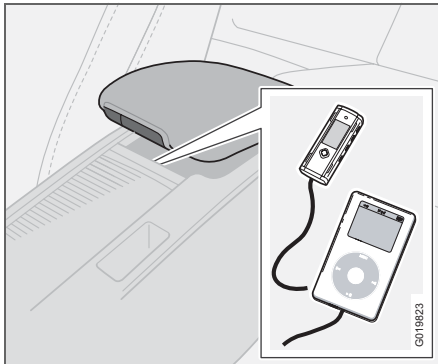

The audio source needs to be selected depending on what is connected:

- Select **iPod** or **USB** using **MODE**. The text **Connect Device** is shown on the display.
- Connect the storage media to the contact in the centre console's storage compartment (see illustration above).

The text **Loading** is shown in the display when the system indexes the files on the storage media. This takes a while.

<sup>1</sup> Option

When the indexing is finished the track information is shown on the display and it is possible to select the track required.

Track selection can take place in two ways:

- Turn **TUNING** (4) clockwise or anticlockwise
- or use the navigation control's (6) right or left-hand button to scroll to the required track.

If the car is equipped with a steering wheel keypad then it is also possible to change tracks using these controls.

### **i** NOTE

The system supports the playback of music files in the most common variants of the MP3, WMA and WAV file formats. There are also variants of these audio formats that are not supported by the system.

### USB memory

To facilitate the use of USB memory, avoid storing any files other than music files in the memory. It takes considerably longer for the system to index storage media that contains items other than compatible music files.

### MP3 player

Many MP3 players have their own file systems that are not supported by the audio system. To be able to use an MP3 player in

the system it must be set in the *USB Removable Device/Mass Storage Device* mode.

### iPod player

The iPod player is charged and powered by the system via the connecting cable. However, if the iPod's battery is completely discharged then it must be charged before the iPod player is connected.

### **i** NOTE

When an iPod is used as an audio source, the car's infotainment system has a menu structure similar to the menu structure of the iPod player. See the iPod manual for detailed information.

For further information, see the accessory manual for *USB/iPod Music Interface*.

## Audio settings

### Adjusting audio settings

Repeatedly pressing **SOUND** browses between the following alternatives. Adjust by turning **TUNING**.

- **BASS** – Bass level.
- **TREBLE** – Treble level.
- **FADER** – Balance between the front and rear speakers.
- **BALANCE** – Balance between the left and right-hand speakers.



## Audio functions

- **SUBWOOFER**<sup>1</sup> – Bass speaker level. The subwoofer must be activated before adjustment is possible. See page 209.
- **CENTRE**<sup>2</sup> – Centre speaker level. Three channel stereo or Pro Logic II must be activated before adjustment is possible. See page 209.
- **SURROUND**<sup>2</sup> – Surround sound level. Pro Logic II must be activated before adjustment is possible. See page 209.

### Activating/deactivating the subwoofer

- Press **MENU** and then **ENTER**.
- Scroll to **Audio settings** and press **ENTER**.
- Scroll to **Subwoofer** and press **ENTER**.

### Surround



Surround settings<sup>2</sup> govern the spatial perception of the sound. Settings and activating/deactivating are separate for each audio source.

The Dolby icon on the display indicates that Dolby Pro Logic II is active. There are three different settings for surround sound:

- **Pro Logic II**
- **3 channel**
- **Off** – 2-channel stereo.

<sup>1</sup> Option

<sup>2</sup> Premium Sound

### Activating/deactivating surround sound

- Press **MENU** and then **ENTER**.
- Scroll to **Audio settings** and press **ENTER**.
- Scroll to **Surround FM/AM/CD/AUX** and press **ENTER**.
- Scroll to **Pro Logic II**<sup>3</sup>, **3 channel** or **Off** and press **ENTER**.

### Equalizer front/rear

The equalizer<sup>4</sup> can be used to adjust different frequency bands separately.

### Adjusting equalizer

- Press **MENU** and then **ENTER**.
- Scroll to **Audio settings** and press **ENTER**.
- Scroll to **Equalizer front** or **Equalizer rear** and press **ENTER**.
- The graphic on the display indicates the audio level of the frequency in question.
- Adjust the level with **TUNING** (4) or up/down on the navigation button. Additional frequencies can be selected using the left/right navigation button.
- Use **ENTER** to save or **EXIT** to close.

<sup>3</sup> Not available in AM and FM mode

<sup>4</sup> Certain audio systems

### Automatic volume control

The auto volume control function allows the audio volume to increase as the speed of the car increases. There are three levels to choose from<sup>5</sup>: **Low**, **Medium** and **High**.

### Adjusting automatic volume control

- Press **MENU** and then **ENTER**.
- Scroll to **Audio settings** and press **ENTER**.
- Scroll to **Automatic volume control** and press **ENTER**.
- Scroll to **Low**, **Medium** or **High** and press **ENTER**.

### Automatic audio settings

The acoustic properties of the passenger compartment are changed when speed increases or when the roof is opened. For this reason the character of the sound is automatically adapted to these situations in order to provide the best possible sound. The adaptation that takes place when the roof is opened is fully automatic.

### Optimum sound reproduction

The audio system is calibrated for optimum sound reproduction by means of digital signal processing.

<sup>5</sup> Not Performance Sound



### Audio functions

This calibration takes into account loudspeakers, amplifiers, passenger compartment acoustics, listener position etc. for each combination of car model and audio system.

There is also a dynamic calibration that takes into account the position of the volume control, radio reception and vehicle speed.

The controls explained in these operating instructions, e.g. **Bass**, **Treble** and **Equalizer**, are only intended for the user to be able to adapt the sound reproduction according to personal taste.



## Radio functions

### Radio controls

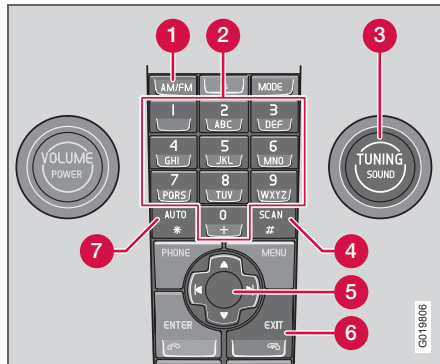

1. **FM/AM** – Wavelength selection
2. Station presets
3. **TUNING** – Knob for station searches
4. **SCAN** – Scanning
5. Navigation button – Tuning and menus
6. **EXIT** – Cancel current function
7. **AUTO** – Automatic storage of stations

### Tuning

#### Automatic tuning

- Select wavelength using **AM/FM** (1).
- Give a brief press, left or right, on the navigation button (5).

#### Manual tuning

- Select wavelength using **AM/FM** (1).
- Adjust the frequency by turning **TUNING** (3).

Tune into a station with a long press (left or right) on the navigation button or by using the steering wheel keypad:

- Hold the right or left side of the navigation button depressed until the desired frequency appears on the display.

As long as the frequency graphic appears on the display, searching can be resumed by briefly pressing the navigation button (left or right) (5).

#### Storing stations

Ten station presets can be stored per wavelength. FM has two memories for presets: **FM1** and **FM2**. Preset stations are selected using the preset buttons (2) or the steering wheel keypad.

#### Storing stations manually

- Tune into a station.
- Hold a station preset button depressed until the message **Station stored** appears on the display.

#### Automatic storage of stations

**AUTO** (7) seeks out the ten strongest radio stations and stores them automatically in a separate memory. The function is especially useful in areas where one is unfamiliar with the radio stations and their frequencies.

#### Starting automatic storage of stations

- Select wavelength using **AM/FM** (1).
- Hold **AUTO** (7) depressed until **Autostoring...** appears on the display.

Once **Autostoring...** disappears from the display, the stations are stored. The radio continues in Auto mode and **Auto** appears on the display. The automatically stored stations can now be selected using the station preset buttons (2).

#### Cancelling automatic storage of stations

- Press **EXIT** (6).

#### Selecting an autostored preset

Allowing the radio to remain in Auto mode provides access to the autostored presets.

- Briefly press **AUTO** (7).
- **Auto** appears on the display.
- Press a preset button (2).

The radio remains in Auto mode until it is exited by a brief press on **AUTO** (7), **EXIT** (6) or **AM/FM** (1).



## Radio functions

### Storing autostored presets in another memory

An autostored preset can be transferred to the FM or AM memory.

- Briefly press **AUTO** (7).

**Auto** appears on the display.

- Press a preset button.
- Press the button under which the station will be stored and hold it depressed until the message **Station stored** appears on the display.

The radio exits Auto mode and the stored station can be selected as a preset.

### Scanning

SCAN (4) automatically searches for strong AM or FM stations. When a station is found, it is played for approx. eight seconds before scanning is resumed.

### Activating/deactivating Scan

- Select wavelength using **AM/FM**.
- Press **SCAN** to activate.

**SCAN** appears on the display. Cancel with **SCAN** or **EXIT**.

### Storing a station

A desired station can be stored as a preset while Scan is active.

- Press a preset button and hold it depressed until the message **Station stored** appears on the display.

Scan is interrupted and the stored station can be selected as a preset.

### RDS functions

Radio Data System – RDS links FM transmitters into a network. An FM transmitter in such a network sends information that gives an RDS radio the following functions:

- Automatically switches to a stronger transmitter if reception in the area is poor.
- Searches for programme form, such as traffic information or news.
- Receives text information on current radio programme.

Some radio stations do not use RDS or only some if its functionality.

### Programme functions

In FM mode, the radio can search for stations with certain programme types. If a desired programme type is found, the radio can switch stations, interrupting the audio source currently in use. For example, if the CD player is in use, it is paused. The interrupting transmission is played at a preset volume; see page 214. The radio returns to the previous

audio source and volume when the set programme type is no longer broadcast.

The programme functions alarm (**ALARM**), traffic information (**TP**), news (**NEWS**), and programme types (**PTY**) interrupt one another in order of priority, where alarm has the highest priority and programme types has the lowest. For further programme interruption settings, see EON and REG on page 214. The programme functions are modified via the menu system, see page 206.

### Returning to the interrupted audio source

Press **EXIT** to return to the interrupted audio source.

### Alarm

This function is used to warn of serious accidents and catastrophes. The alarm cannot be temporarily interrupted or deactivated. The message **ALARM!** appears on the display when an alarm message is transmitted.

### Traffic information – TP

**TP**

This function allows traffic information sent within a set station's RDS network to break through. **TP** indicates that the function is activated.

If the set station can send traffic information then **TP** appears on the display.



## Radio functions

### Activating/deactivating TP

- Press **MENU** and then **ENTER**.
- Scroll to **TP** and press **ENTER**.

### TP from current station/all stations

The radio can interrupt with traffic information from only the set (current) station or from all stations.

- Select an FM station.
- Press **MENU** and then **ENTER**.
- Scroll to **Advanced radio settings** and press **ENTER**.
- Scroll to **TP** and press **ENTER**.
- Scroll to **TP Station** and press **ENTER**.

Either **TP from current station** or **TP from all stations** will appear on the display.

- Press **ENTER**.

### Activating/deactivating TP search

TP search is useful during long journeys while an audio source other than the radio is being played. The function automatically searches for traffic information within different RDS networks.

- Press **MENU** and then **ENTER**.
- Scroll to **Advanced radio settings** and press **ENTER**.
- Scroll to **TP** and press **ENTER**.
- Scroll to **TP search** and press **ENTER**.

### News

#### NEWS

This function allows news broadcasts within a set station's RDS network to break through. The message **NEWS** indicates that the function is active.

### Activating/deactivating News

- Press **MENU** and then **ENTER**.
- Scroll to **News** and press **ENTER**.

### News from current station/all stations

The radio can interrupt with news from only the set (current) station or from all stations.

- Select an FM station.
- Press **MENU** and then **ENTER**.
- Scroll to **Advanced radio settings** and press **ENTER**.
- Scroll to **News station** and press **ENTER**.

Either **News from current station** or **News from all stations** will appear on the display.

- Press **ENTER**.

### Programme types – PTY

#### PTY

The PTY function can be used to select different programme types, such as **Pop music** and **Serious classic**. The PTY symbol indicates that the function is active. The

function allows programme types transmitted within a set station's RDS network to break through.

### Activating/deactivating PTY

- Select **FM1** or **FM2** with **FM/AM**.
- Press **MENU** and then **ENTER**.
- Scroll to **PTY** and press **ENTER**.
- Scroll to **Select PTY** and press **ENTER**.

A list of programme types appears: **Current affairs**, **Information** etc. The PTY function is activated by selecting programme types and deactivated by clearing all PTYs.

- Select the desired programme types or **Clear all PTY**.

### Search PTY

This function searches the entire wavelength for the selected programme type.

- Activate PTY.
- Press **MENU** and then **ENTER**.
- Scroll to **PTY** and press **ENTER**.
- Scroll to **Search PTY** and press **ENTER**.

If the radio finds any of the selected programme types, **>| To seek** appears on the display. Press the navigation button to the right to continue searching for another broadcast of the selected programme types.



## Radio functions

### Display of programme type

The programme type of the current station can be shown on the display.

#### **i** NOTE

Not all radio stations support this function.

### Activating/deactivating display

- Press **MENU** and then **ENTER**.
- Scroll to **PTY** and press **ENTER**.
- Scroll to **Show PTY** and press **ENTER**.

### Radio text

Some RDS stations transmit information on programme content, artists, etc. This information can be shown on the display.

### Activating/deactivating radio text

- Press **MENU** and then **ENTER**.
- Scroll to **Radio text** and press **ENTER**.

### Automatic frequency update – AF

The AF function selects one of the strongest transmitters for a set station. The radio may sometimes need to search through the entire FM wavelength to find a strong transmitter. If this occurs, the radio mutes and **PI seek Exit to cancel** appears on the display.

### Activating/deactivating AF

- Press **MENU** and then **ENTER**.
- Scroll to **Advanced radio settings** and press **ENTER**.
- Scroll to **AF** and press **ENTER**.

### Regional radio programmes – REG

#### **PTY**

This function causes the radio to continue with a regional transmitter even if its signal strength is low.

**REG** indicates that the function is active. The regional function is normally deactivated.

### Activating/deactivating REG

- Press **MENU** and then **ENTER**.
- Scroll to **Advanced radio settings** and press **ENTER**.
- Scroll to **Regional** and press **ENTER**.

### Enhanced Other Networks – EON

The EON function is particularly useful in urban areas with many regional radio stations. It allows the distance between the car and the radio station transmitter determine when programme functions should interrupt the current audio source.

- **Local** – interrupts only if the radio station transmitter is close.

- **Distant**<sup>1</sup> – interrupts if the station transmitter is far away, even if there is a lot of static.
- **Off** – no interruption for programmes from other transmitters.

### Activating/deactivating EON

- Press **MENU** and then **ENTER**.
- Scroll to **Advanced radio settings** and press **ENTER**.
- Scroll to **EON** and press **ENTER**.
- Scroll to **Local**, **Distant** or **Off** and press **ENTER**.

### Resetting RDS functions

Resets all radio settings to the original factory settings.

- Press **MENU** and then **ENTER**.
- Scroll to **Advanced radio settings** and press **ENTER**.
- Scroll to **Reset all** and press **ENTER**.

### Volume control, programme types

The interrupting programme form is heard at the volume selected for such. If the volume level is adjusted during the programme interruption, the new level is saved until the next programme interruption.

<sup>1</sup> Default/Factory setting



## CD functions

### CD function controls

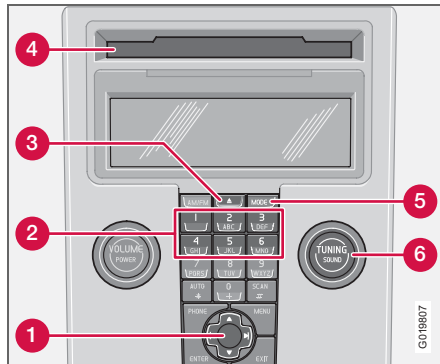

1. Navigation button – Fast forward/rewind, track selection and menus
2. CD changer position selection<sup>1</sup>
3. CD insertion/eject
4. CD insertion/eject slot
5. **MODE** – Audio source selection CD and AUX
6. **TUNING** – Knob for track selection

### Starting playback (CD player)

If a music CD is in the player when the audio system is in CD mode then playback is

<sup>1</sup> High Performance and Premium Sound

started automatically. Otherwise, load a disc and change to CD mode by pressing **MODE**.

### Starting playback (CD changer)

If a CD position with a music CD is already selected when the audio system is activated then playback starts automatically. Otherwise change to CD changer mode using **MODE** and select a disc with the number buttons **1–6** or Up/Down on the navigation button.

### Inserting a CD (CD changer)

- Select an empty position with buttons **1–6** or Up/Down on the navigation button.

An empty position is marked on the display. The text **Insert disc** shows that a new disc can be inserted. The CD changer can hold up to six CDs.

- Insert a CD in the slot of the CD changer.

### CD eject

A CD will stay in the ejected position for approx. 12 seconds. Following which it is re-inserted into the player and playback continues.

Eject individual discs by pressing the eject button (3).

Eject all discs with one long press on the eject button. The entire magazine is emptied disc by disc. The message **Eject all** is shown in the display.

### Pause

If the volume is turned down completely, the CD player is stopped. The player is restarted when volume is increased.

### Audio files<sup>1</sup>

The CD player also supports MP3 and WMA format audio files.

### NOTE

Certain types of copy-protected audio files cannot be read by the player.

When a CD containing audio files is inserted into the player the disc's directory structure is read in. It may take a while before playback starts depending on the quality of the disc.

### Navigation and playback

If a disc containing audio files is inside the CD player then **ENTER** leads to the disc's directory structure. The directory structure is navigated in the same way as the audio system's menu structure. Audio files have the symbol and directories have the symbol . Start audio file playback with **ENTER**.

When the playback of a file is finished the playback of the other files in the same directory continues. Directory change takes place





## CD functions

automatically when all files in the current directory have been played back.

Press left/right on the navigation button if the display is not wide enough to show the whole audio file name.

### Fast-wind/change CD tracks and audio files

Short presses right/left on the navigation button are used to scroll between CD tracks/audio files. Long presses are used to fast-wind CD tracks/audio files. **TUNING** (or the steering wheel keypad) can also be used for this purpose.

### Scan CD

This function plays the first ten seconds of each CD track/audio file. Press **SCAN** to activate. Interrupt with **EXIT** or **SCAN** to continue playback of the current CD track/audio file.

### Random

This function plays the tracks in random order. The random CD tracks/audio files can be scrolled through in the normal way.



#### NOTE

It is only possible to scroll between random CD tracks on the current disc.

Different messages appear on the display depending on which random function has been selected.

- **RANDOM** means that the tracks from only one music CD are played
- **RND ALL** means that all tracks on all music CDs in the CD changer are played.
- **RANDOM FOLDER** means that the audio files in a directory on the current CD are played.

#### Activating/deactivating (CD player)

- If a normal music CD is being played:
- Press **MENU** and then **ENTER**.
- Scroll to **Random** and press **ENTER**.

If a disc with audio files is being played:

- Press **MENU** and then **ENTER**.
- Scroll to **Random** and press **ENTER**.
- Scroll to **Folder** or **Disc** and press **ENTER**.

#### Activating/deactivating (CD changer)

If a normal music CD is being played:

- Press **MENU** and then **ENTER**.
- Scroll to **Random** and press **ENTER**.
- Scroll to **Single disc** or **All discs** and press **ENTER**.

The option **All discs** only applies to the music CDs in the changer.

If a CD with audio files is being played:

- Press **MENU** and then **ENTER**.
- Scroll to **Random** and press **ENTER**.
- Scroll to **Single disc** or **Folder** and press **ENTER**.

The function is deactivated when another CD is selected.

#### Disc text

If title information is stored on a music CD it can be shown on the display<sup>1</sup>.

#### Activating/deactivating

- Start CD playback.
- Press **MENU** and then **ENTER**.
- Scroll to **Disc text** and press **ENTER**.

#### CDs

Using low quality CD discs could result in poor or non-existent sound.



#### IMPORTANT

Only use standard discs (12 cm in diameter). Do not use CDs with adhesive disc labels. The heat in the CD player may cause the label to come off, damaging the CD player.

<sup>1</sup> Only applies to CD changer

**Menu structure – audio system****FM menu**

1. News
2. TP
3. PTY
4. Radio text
5. Advanced radio settings
6. Audio settings<sup>1</sup>

**AM menu**

1. Audio settings<sup>1</sup>

**CD menu**

1. Random
2. News
3. TP
4. Disc text
5. Audio settings<sup>1</sup>

**CD changer menu**

1. Random
2. News
3. TP
4. Disc text
5. Audio settings<sup>1</sup>

**AUX menu**

1. AUX volume
2. News
3. TP
4. Audio settings<sup>1</sup>

<sup>1</sup> Certain audio systems.



# 10 Infotainment system

## Phone functions (option)

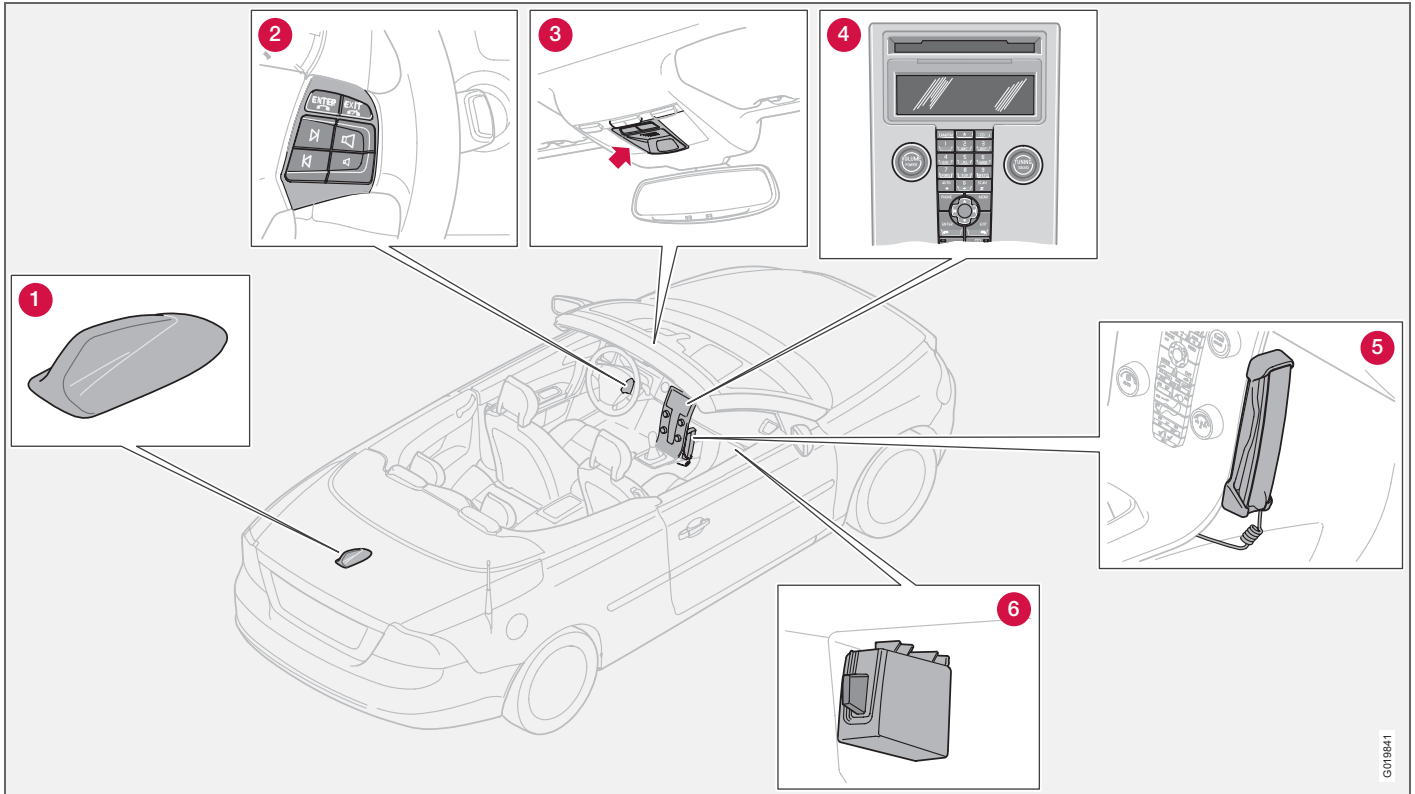

Phone system components

G019841



## Phone functions (option)

### Phone system components

#### 1. Antenna

#### 2. Steering wheel keypad (option)

Most phone system functions can be accessed via the keypad. See page 220.

#### 3. Microphone

The handsfree microphone is integrated in the roof console beside the rearview mirror.

#### 4. Centre console control panel

All phone functions (except call volume) can be regulated via the control panel.

#### 5. Privacy handset (option)

#### 6. SIM card reader

### General

- Always put traffic safety first.
- If the driver needs to use the privacy handset, park the car in a safe place first.
- Switch off the phone system when refueling the car.
- Switch off the system near blasting work.
- Only entrust phone system servicing to an authorised Volvo workshop.

### Emergency calls

Emergency calls to alarm centres can be made without a SIM card as long as there is coverage by a GSM operator.

#### Making an emergency call

- Activate the phone.
- Ring the emergency number that applies to your region (within EU: 112).
- Press **ENTER**.

### IDIS

(Intelligent Driver Information System) The IDIS system allows incoming phone calls and text (SMS) messages to be delayed so that the driver can concentrate on driving. Incoming calls and text messages can be delayed five seconds before they are connected. Missed calls are shown on the display. IDIS can be deactivated using menu function 5.6.2. See page 226.

### SIM card

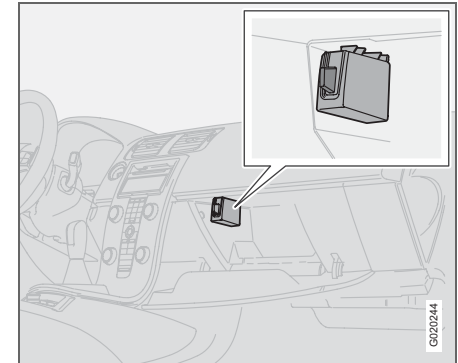

The phone can only be used with a valid SIM card (Subscriber Identity Module). The card is available from various network operators. Contact your network provider if you experience difficulties with the SIM card.

#### **i** NOTE

The built-in phone cannot read 3G only SIM cards. Combined 3G/GSM cards do work. Contact your network operator if you need to change your SIM card.



# 10 Infotainment system

## Phone functions (option)

### Double SIM cards<sup>1</sup>

Many network operators offer two SIM cards for the same phone number. The extra SIM card can be used in the car.

### Inserting the SIM card

- Switch off the phone and open the glove-box.
- Pull out the SIM card holder (1) in the SIM card reader.
- Position the SIM card in the holder with the metal surface visible. The bevelled edge of the SIM card should align with the bevel of the SIM card holder.
- Carefully press in the SIM card holder.

### Menus

Page 206 describes how to control phone functions with the menu system.

### Traffic safety

For safety reasons, parts of the phone menu system cannot be accessed at speeds in excess of 8 km/h. Only activities started in the menu system can be completed. The speed limiter can be deactivated using menu function 5.6.1 Menu lock, see page 225.

<sup>1</sup> Certain markets

### Phone controls

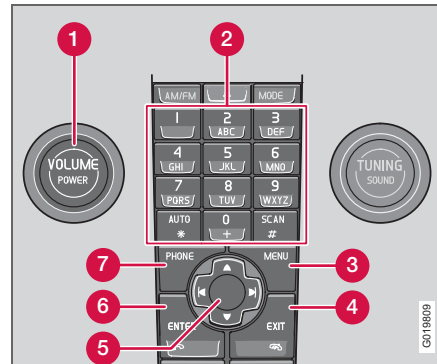

Centre console control panel

1. **VOLUME** – Control the background volume from the radio, for example, during a call.
2. Number and letter buttons
3. **MENU** – Opens the main menu
4. **EXIT** – End/refuse calls, clear entered characters
5. Navigation button – Scroll in menus and character rows
6. **ENTER** – Accept calls, activate the phone from standby mode
7. **PHONE** – On/off and standby mode

### Steering wheel keypad

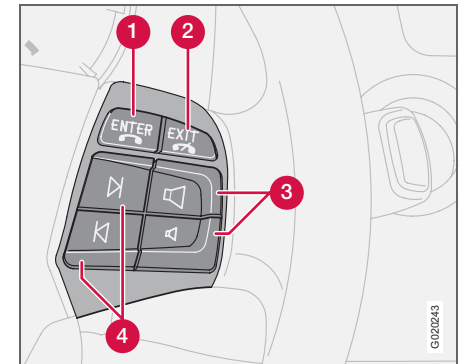

When the phone is active, the steering wheel keypad is locked to phone functions. To control the audio system, the phone must be in standby mode.

1. **ENTER** – Works the same as on the control panel.
2. **EXIT** – Works the same as on the control panel
3. Call volume – Increase/decrease
4. Navigation buttons – Scroll in menus



## Phone functions (option)

### On/Off

A handset appears on the display when the phone system is active or in standby mode. If the ignition key is turned to position **0** when the phone is in one of these modes, the phone automatically resumes this mode the next time the key is turned to position **I** or **II**.

### Activating the phone system

Phone system functions can only be used when the phone is in active mode.

- Press **PHONE**.
- Enter the PIN code (if necessary) and press **ENTER**.

### Deactivating the phone system

No calls can be received when the phone is deactivated.

- Hold **PHONE** depressed until the phone is activated.

### Standby

In standby mode, the audio system can be in use while calls are received. However, it is not possible to make calls when in standby mode.

### Putting the phone in standby mode

The phone must first be in active mode before it can be put in standby mode.

- Press **PHONE** or **EXIT**.

### Activating from standby mode

- Press **PHONE**.

### Making and receiving calls

If the privacy handset is raised when a phone call is started, the sound will come from the handsfree system. For information on switching between privacy handset and handsfree during a call, see page 223.

### To call

- Activate the phone system (if necessary).
- Dial the number or use the phone book, see page 223.
- Press **ENTER** or lift the handset. Release the handset by pressing it down.

### Receiving a call

For Auto answer, see menu option 4.3, page 225.

- Press **ENTER** or lift the handset. Release the handset by pressing it down.

### Ending a call

- Press **EXIT** or hang up the handset.

### Refusing a call

- Press **EXIT**.

### Call waiting

A two-tone signal during a phone call indicates that there is another incoming call. **Answer?** appears on the display. The call can be refused or taken in the normal manner. If the incoming call is taken, the previous call is put on hold.

### Putting a call on hold/resuming a call

- Press **MENU**.
- Scroll to **Hold** or **Hold off** and press **ENTER**.

### Dialling a third party

- Put the call on hold.
- Dial the number of the third party.

### Switching between calls

- Press **MENU**.
- Scroll to **Swap** and press **ENTER**.

### Starting a conference call

A conference call consists of at least three parties that can talk to one another. Once a conference call has been initiated, no more parties can be connected. All calls are ended when the conference call is ended.

- Start two phone calls
- Press **MENU**.
- Scroll to **Join** and press **ENTER**.



# 10 Infotainment system

## Phone functions (option)

### Volume

The phone uses the driver's door or centre speaker<sup>1</sup>.

### Call volume



Call volume is regulated with the buttons of the steering wheel keypad.

If the privacy handset is used, volume is regulated with a wheel on the side of

the handset.

### Audio system volume

Audio system volume is temporarily lowered during a phone call. Once the call is ended the previous volume is resumed. If the volume is regulated during the call, the new level is retained once the call is ended.

Sound can also be automatically muted during a phone call; see menu 5.5.3, page 226. This function is only available with the Volvo integrated phone system.

### Entering text

Text is entered using the phone keypad.

- Press the button with the desired character - once for the first character on the

button, twice for the second, etc. See table.

- Press 1 for a space. If two characters in a row are to be entered using the same button, press \* or wait a few seconds.

A brief press on **EXIT** will clear an entered character. A long press on **EXIT** will clear all entered characters.

1	space 1- ? ! , . : " ' ( )
2	a b c 2 ä å à æ ç
3	d e f 3 è é
4	g h i 4 ì
5	j k l 5
6	m n o 6 ñ ò ð Ø
7	p q r s 7 ß
8	t u v 8 ü ù
9	w x y z 9
*	Used if two characters are to be entered with the same button.
0	+ 0 @ * # & \$ £ / %
#	Switch between upper and lower case.

### Handling numbers

#### Calling the last number dialled

The phone automatically stores the last phone numbers dialled.

- Press **ENTER**.
- Scroll to a number and press **ENTER**.

#### Phone book

If the phone book contains the desired party's contact information, this are shown on the display. Contact information can be stored on the SIM card and in the phone.

#### Storing contacts in the phone book

- Press **MENU**.
- Scroll to **Phone book** and press **ENTER**.
- Scroll to **New number** and press **ENTER**.
- Enter a name and press **ENTER**.
- Enter a number and press **ENTER**.
- Scroll to **SIM card** or **Phone** and press **ENTER**.

#### Searching for contacts in the phone book

Use the down arrow of the navigation button instead of **MENU** for direct access to the **Search** menu.

- Press **MENU**.
- Scroll to **Phone book** and press **ENTER**.

<sup>1</sup> Premium Sound

**Phone functions (option)**

- Scroll to **Search** and press **ENTER**.
- Enter the first few letters of the item and press **ENTER**, or simply press **ENTER**.
- Scroll to an item and press **ENTER**.

**Copying entries between the SIM card and Phone book**

- Press **MENU**.
- Scroll to **Phone book** and press **ENTER**.
- Scroll to **Copy all** and press **ENTER**.
- Scroll to **SIM to phone** or **Phone to SIM** and press **ENTER**.

**Deleting contacts from the phone book**

- Press **MENU**.
- Scroll to **Phone book** and press **ENTER**.
- Scroll to **Search** and press **ENTER**.
- Enter the first few letters of the item and press **ENTER**, or simply press **ENTER**.
- Scroll to the item to be erased and press **ENTER**.
- Scroll to **Erase** and press **ENTER**.

**Erase all contacts**

- Press **MENU**.
- Scroll to **Phone book** and press **ENTER**.
- Scroll to **Erase SIM** or **Erase phone** and press **ENTER**.

If required, enter phone code. The factory-set default code is 1234.

**Speed dial**

A keypad button (1-9) can be used as a speed dial number for a contact in the phone book.

- Press **MENU**.
- Scroll to **Phone book** and press **ENTER**.
- Scroll to **One-key dial** and press **ENTER**.
- Scroll to **Select numbers** and press **ENTER**.
- Scroll to the digit of the keypad button for the speed dial number and press **ENTER**.
- Enter the first few letters of the item and press **ENTER**, or simply press **ENTER**.
- Scroll to an item and press **ENTER**.
- Hold EXIT depressed to leave the menu system.

**Calling using speed dial**

- Hold the desired keypad button for approx. two seconds or briefly press the button and then **ENTER**.

**NOTE**

When the phone is switched on, it takes a while before speed dialling is available.

To use the speed dial function **One-key dial** must be activated in the **Phone book** menu, see page 227.

**Calling from the phone book**

- Press **MENU**.
  - Scroll to **Phone book** and press **ENTER**.
- All contacts in the phone book memory are displayed. The number of contacts displayed can be reduced by entering part of the contact's name.
- Scroll to a contact and press **ENTER**.

**NOTE**

Press **ENTER** to dial.

**Functions during a call**

Several functions are available during a call. Some functions can only be used when a call is on hold.

Press **MENU** to access the In-call menu and scroll to one of the following alternatives:

- **Mute/Mute off** – Mute mode.
- **Hold/Hold off** – Put a call on hold or resume a call.
- **Handsfree/Handset** – Use handsfree or the privacy handset.
- **Phone book** – Access the phone book.
- **Join** – Conference calling (available if more than three parties are connected)





## Phone functions (option)

- **Swap** – Switch between two calls (available if up to three parties are connected).

### SMS – Short Message Service

#### Reading SMS

- Press **MENU**.
- Scroll to **Messages** and press **ENTER**.
- Scroll to **Read** and press **ENTER**.
- Scroll to a message and press **ENTER**.

The message text appears in the display. Additional selections can be made by pressing **ENTER**. Hold **EXIT** depressed to leave the menu system.

#### Writing and sending

- Press **MENU**.
- Scroll to **Messages** and press **ENTER**.
- Scroll to **Write new** and press **ENTER**.
- Enter text and press **ENTER**.
- Scroll to **Send** and press **ENTER**.
- Enter a phone number and press **ENTER**.

### IMEI number

To block the phone, you must provide your network operator with the phone's IMEI number. This is a 15 digit serial number that is programmed into the phone. Dial \*#06# to display this number. Make a note of this number and keep it in a safe place.

### Specifications

Output	2 W
SIM card	Small
Memory entries	255 <sup>1</sup>
SMS (Short Message Service)	Yes
Data/Fax	No
Dualband (900/1800 MHz)	Yes

<sup>1</sup>The capacity of the SIM card's memory varies depending on the subscription.



## Menu structure – phone

### Overview

#### 1. Call register

- 1.1. Missed calls
- 1.2. Received calls
- 1.3. Dialed no.
- 1.4. Erase list
  - 1.4.1. All calls
  - 1.4.2. Missed calls
  - 1.4.3. Received calls
  - 1.4.4. Dialed no.
- 1.5. Call duration
  - 1.5.1. Last call
  - 1.5.2. Call count
  - 1.5.3. Total time
  - 1.5.4. Reset timers

#### 2. Messages

- 2.1. Read
- 2.2. Write
- 2.3. Message sett
  - 2.3.1. SMSC number
  - 2.3.2. Validity time
  - 2.3.3. Message type

#### 3. Phone book

- 3.1. New number
- 3.2. Search
- 3.3. Copy all
  - 3.3.1. SIM to phone
  - 3.3.2. Phone to SIM
- 3.4. One-key dial
  - 3.4.1. Active
  - 3.4.2. Select numbers
- 3.5. Erase SIM
- 3.6. Erase phone
- 3.7. Memory status

#### 4. Call options

- 4.1. Send my no.
- 4.2. Call waiting
- 4.3. Auto answer
- 4.4. Auto re-dial
- 4.5. Diversions
  - 4.5.1. All calls
  - 4.5.2. When engag.
  - 4.5.3. Not answered
  - 4.5.4. Not reachable
  - 4.5.5. Fax calls
  - 4.5.6. Data calls
  - 4.5.7. Cancel all

#### 5. Phone sett.

- 5.1. Network
  - 5.1.1. Auto
  - 5.1.2. Manual select
- 5.2. Language
  - 5.2.1. English UK
  - 5.2.2. English US
  - 5.2.3. Español
  - 5.2.4. Français CAN
  - 5.2.5. Français FR
  - 5.2.6. Italiano
  - 5.2.7. Nederlands
  - 5.2.8. Português BR
  - 5.2.9. Português P
  - 5.2.10. Suomi
  - 5.2.11. Svenska
  - 5.2.12. Dansk
  - 5.2.13. Deutsch
- 5.3. SIM security
  - 5.3.1. On
  - 5.3.2. Off
  - 5.3.3. Auto
- 5.4. Edit codes
  - 5.4.1. PIN code
  - 5.4.2. Phone code
- 5.5. Sounds
  - 5.5.1. Ring volume
  - 5.5.2. Ring signal



## Menu structure – phone

- 5.5.3. Mute radio
- 5.5.4. Msg. beep
- 5.6. Traff. safety
  - 5.6.1. Menu lock
  - 5.6.2. IDIS
- 5.7. Factory sett.

### Description of menu options

#### 1. Call register

##### 1.1. Missed calls

List of missed calls. You can choose to call, erase or store the number in the phone book.

##### 1.2. Received calls

List of received calls. You can choose to call, erase or store the number in the phone book.

##### 1.3. Dialed no.

List of previously dialed numbers. You can choose to call, erase or store the number in the phone book.

##### 1.4. Erase list

Erase the lists found in the menus 1.1, 1.2 and 1.3 as below.

- 1.4.1. All
- 1.4.2. Missed
- 1.4.3. Received
- 1.4.4. Dialed no.

##### 1.5. Call duration

Duration of all calls or of the most recent call. The phone code is required to reset the call timer (see menu 5.4).

- 1.5.1. Last call
- 1.5.2. Call count

- 1.5.3. Total time
- 1.5.4. Reset timers

#### 2. Messages

##### 2.1. Read

Received text messages. Select whether to erase, forward, change or save the entire message or parts of it.

##### 2.2. Write

Write a message using the keypad. Choose whether to save or send it.

##### 2.3. Message sett

Enter the number (SMSC number) of the message centre to which messages are to be transferred as well as how long they are to be saved at the message centre. Contact your network operator for information on message settings. Normally, these settings should not be altered.

- 2.3.1. SMSC number
- 2.3.2. Validity time
- 2.3.3. Message type

#### 3. Phone book

##### 3.1. New number

Store names and phone numbers in the phone book, see page 222.



## Menu structure – phone

### 3.2. Search

Search for a name in the phone book.

### 3.3. Copy all

Copy phone numbers and names from the SIM card to the phone memory.

3.3.1. From SIM to phone memory

3.3.2. From phone to SIM memory

### 3.4. One-key dial

A number stored in the phone book can be stored as a speed dial number.

### 3.5. Erase SIM

Erase the entire SIM card memory.

### 3.6. Erase phone

Erase the entire phone memory.

### 3.7. Memory status

Shows how many positions are occupied in the SIM card and phone memory. The table shows how many of the total number of positions are occupied, e.g. 100 (250).

## 4. Call options

### 4.1. Send my no.

Displays or hides your phone number to/from the person you call. Contact your network operator regarding ex-directory numbers.

### 4.2. Call waiting

Be alerted during a phone call that there is another incoming call.

### 4.3. Auto answer

Automatically answers incoming calls.

### 4.4. Auto re-dial

Calls a previously engaged number.

### 4.5. Diversions

Choose when and what type of calls are to be diverted to a specified phone number.

4.5.1. All calls (this setting only applies during the call in progress).

4.5.2. When engaged.

4.5.3. Not answered

4.5.4. Not reachable

4.5.5. Fax calls

4.5.6. Data calls

4.5.7. Cancel all

## 5. Phone settings

### 5.1. Network

Choose a network automatically or manually.

The selected operator is shown on the display in the phone's basic mode.

5.1.1. Auto

5.1.2. Manual select

### 5.2. Language

Select the phone language.

5.2.1. English UK

5.2.2. English US

5.2.3. Español

5.2.4. Français CAN

5.2.5. Français FR

5.2.6. Italiano

5.2.7. Nederlands

5.2.8. Português BR

5.2.9. Português P

5.2.10. Suomi

5.2.11. Svenska

5.2.12. Dansk

5.2.13. Deutsch

### 5.3. SIM security

Select if the PIN code should be on, off or if the phone should automatically give the PIN code.

5.3.1. On

5.3.2. Off

5.3.3. Auto

### 5.4. Edit codes

Change PIN or phone code. Make a note of the codes and keep them in a safe place.

5.4.1. PIN code



### Menu structure – phone

- 5.4.2. Phone code. The factory-set phone code 1234 is used until you change to your own code. The phone code is used to reset the call timer.

#### 5.5. Sounds

- 5.5.1. Volume. Adjust the ring tone volume.
- 5.5.2. Ring signal. There are seven different ring tones.
- 5.5.3. Mute radio: On/Off
- 5.5.4. Msg. beep

#### 5.6. Traffic safety

- 5.6.1. Menu lock. Deactivating the menu lock allows access to the entire menu while driving.
- 5.6.2. IDIS. If the IDIS function is deactivated, incoming calls are not delayed, regardless of the driving situation.

#### 5.7. Factory sett.

Reset the system's factory settings.

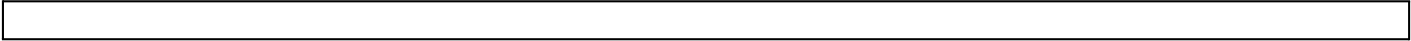

Type designation .....	232
Dimensions and weights .....	233
Engine specifications .....	235
Engine oil .....	237
Fluids and lubricants .....	241
Fuel .....	242
Catalytic converter .....	244
Electrical system .....	245
Type approval .....	247

01 10

## SPECIFICATIONS



# 11



## Type designation

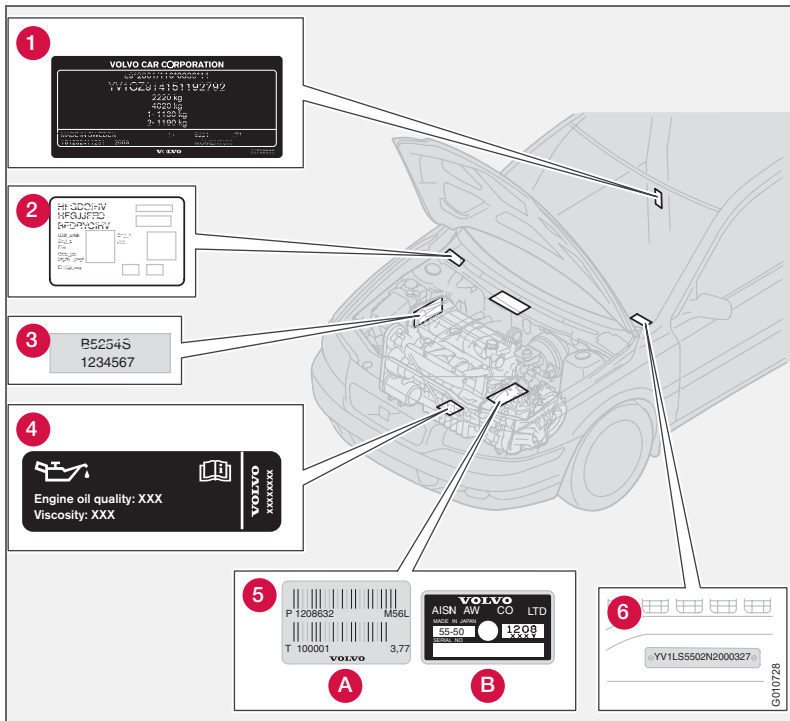

Knowing the car's type designation, vehicle identification and engine numbers can facilitate all contact with a Volvo dealer regarding the car and when ordering spare parts and accessories.

1. Type designation, vehicle identification number, maximum permissible weights, codes for colour and upholstery and type approval number.
2. Decal for parking heater.
3. Engine type designation, component and serial number.
4. Decal for engine oil.
5. Gearbox type designation and serial number:
  - (a) manual gearbox
  - (b) automatic gearbox
6. VIN number (type and model year designation plus chassis number).

Further information on the car is presented in the registration document.

## Dimensions and weights

## Dimensions

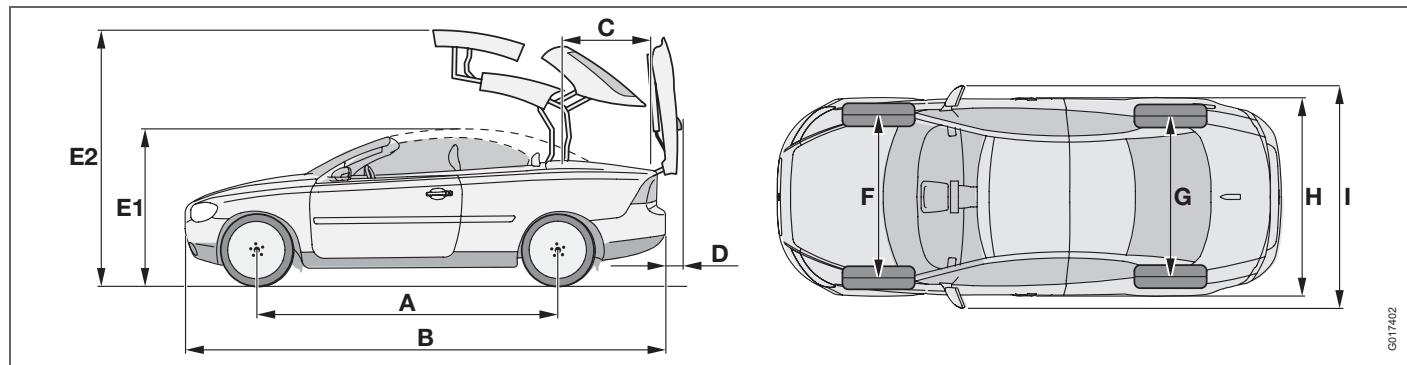

G017402

Position in illustration	Dimensions	mm
A	Wheelbase	2640
B	Length	4582
C	Load length	850
D	Boot lid, raised	approx. 200
E1	Height	1400
E2	Height	approx. 2000
F	Front track	1550
G	Rear track	1560
H	Width	1836
I	Width including door mirrors	2025

## Dimensions and weights

## Weights

Kerb weight includes the driver, the fuel tank 90 % full and all fluids. The weight of passengers and accessories, such as a towbar, load carriers, space box etc. and towball load (when a trailer is hitched, see table), influences the payload and must not be included in the kerb weight. Permitted weight (in addition to driver) = Gross vehicle weight – Kerb weight.

 **WARNING**

The car's driving characteristics change depending on how heavily it is loaded and how the load is distributed.

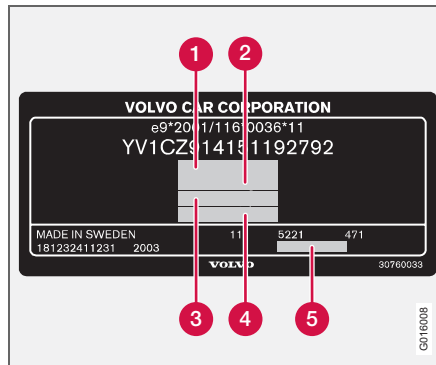

See decal location on page 232.

1. Gross vehicle weight
2. Max. train weight (car+trailer)
3. Max. front axle load
4. Max. rear axle load
5. Equipment level

**Maximum load:** See registration document.

## Trailer with brakes

Maximum trailer weight (kg)	Maximum towball load (kg)
1500	75

## Trailer without brakes

Maximum trailer weight (kg)	Maximum towball load (kg)
700	50

<b>Engine specifications</b>
------------------------------

	<b>2.4</b>	<b>2.4i</b>	<b>T5</b>
Engine designation	B5244S5	B5244S4	B5254T7
Output (kW/rpm)	103/5000	125/6000	169/5000
(hp/rpm)	140/5000	170/6000	230/5000
Torque (Nm/rpm)	220/4000	230/4400	320/1500–5000
No. of cylinders	5	5	5
Bore (mm)	83	83	83
Stroke (mm)	90.0	90.0	93.2
Swept volume (litres)	2.44	2.44	2.52
Compression ratio	10.3:1	10.3:1	9.0:1

Engine type designation, component and serial number can be read on the engine, see page 232.

## Engine specifications

	2.0D	2.4D	D5
Engine designation	D4204T	D5244T9 <sup>1</sup>	D5244T8
Output (kW/rpm)	100/4000	120/5500	136/4000
(hp/rpm)	136/4000	163/5500	185/4000
Torque (Nm/rpm)	320/2000	340/1750-2750	350/222-2700
No. of cylinders	4	5	5
Bore (mm)	85	81	81
Stroke (mm)	88.0	93.2	93.2
Swept volume (litres)	2.00	2.40	2.40
Compression ratio	18.5:1	17.0:1	17.0:1

<sup>1</sup>Belgium

Engine type designation, component and serial number can be read on the engine, see page 232.

### Adverse driving conditions

Check the oil level more frequently for long journeys:

- towing a caravan or trailer.
- in mountainous regions.
- at high speeds.
- in temperatures colder than  $-30\text{ }^{\circ}\text{C}$  or hotter than  $+40\text{ }^{\circ}\text{C}$ .

This can produce abnormally high oil temperature or oil consumption.

Also check the oil level more often if the car is often driven short distances (less than 10 km) when temperatures are low (below  $+5\text{ }^{\circ}\text{C}$ ).

Choose a fully synthetic engine oil for adverse driving conditions. It provides extra protection for the engine.

Volvo recommends Castrol oil products.

### ! IMPORTANT

In order to fulfil the requirements for the engine's service intervals all engines are filled with a specially adapted synthetic engine oil at the factory. The choice of oil has been made very carefully with regard to service life, starting characteristics, fuel consumption and environmental impact.

An approved engine oil must be used in order that the recommended service intervals can be applied. Only use a prescribed grade of oil (see the engine compartment decal) for both filling and oil change, otherwise you will risk affecting service life, starting characteristics, fuel consumption and environmental impact.

Volvo Car Corporation disclaims all warranty liability if engine oil of the prescribed grade and viscosity is not used.

### Viscosity chart

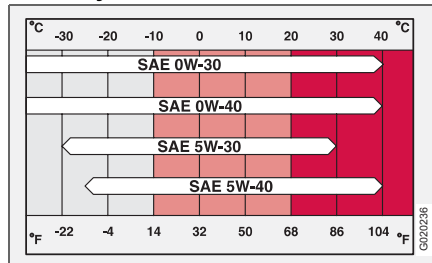

# 11 Specifications

## Engine oil

### Oil decal

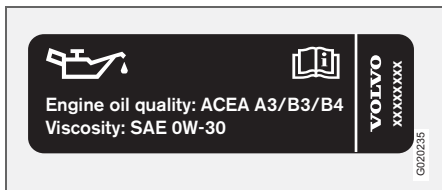

When the oil decal shown alongside here is in the car's engine compartment, the following applies. See location on page 232.

**Oil grade: ACEA A3/B3/B4**

**Viscosity: SAE 0W-30**

When driving under adverse conditions, use ACEA A5/B5 SAE 0W-30.

Engine variant		Volume between MIN-MAX (litres)	Volume <sup>1</sup> (litres)
2.4	B5244S5 <sup>2</sup>	1.3	5.8
2.4i	B5244S4 <sup>2</sup>		
T5	B5254T7 <sup>2</sup>		

<sup>1</sup>Including filter change.

<sup>2</sup>Does not apply to Europe, for Europe see page 240.

## Engine oil

### Oil decal

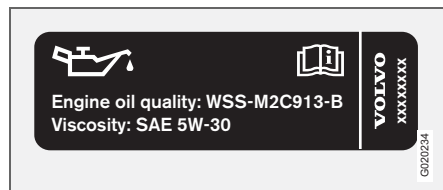

When the oil decal shown alongside here is in the car's engine compartment, the following applies. See location on page 232.

**Oil grade: WSS-M2C913-B**

**Viscosity: SAE 5W-30**

When driving under adverse conditions, use ACEA A5/B5 SAE 0W-30.

Engine variant		Volume between MIN-MAX (litres)	Volume <sup>1</sup> (litres)
D5	D5244T8	1.5	6.0
2.4D	D5244T9		
2.0D	D4204T	2.0	5.5

<sup>1</sup>Including filter change



# 11 Specifications

## Engine oil

### Oil decal

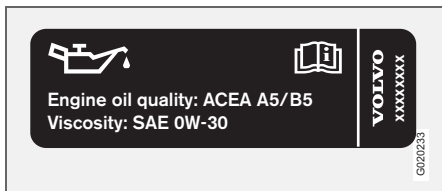

When the oil decal shown alongside here is in the car's engine compartment, the following applies. See location on page 232.

**Oil grade: ACEA A5/B5**

**Viscosity: SAE 0W-30**

Engine variant		Volume between MIN-MAX (litres)	Volume <sup>1</sup> (litres)
2.4	B5244S5	1.3	5.5 <sup>2</sup>
2.4i	B5244S4		
T5	B5254T7		

<sup>1</sup>Including filter change

<sup>2</sup>Europe only, for other markets, see page 238.

<b>Fluids and lubricants</b>
------------------------------

Fluid	System	Volume (litres)	Recommended oil grade
Gearbox oil	2.4 Manual 5-speed	2.1	Transmission fluid: MTF 97309-10
	2.4i Manual 5-speed	2.1	
	T5 Manual 6-speed	2.0	
	T5 Automatic gearbox	7.75	Transmission fluid: JWS 3309
	2.0D Manual 6 speed	1.7	Transmission fluid: WSD-M2C200-C
	D5 Automatic gearbox	7.75	Transmission fluid: JWS 3309
Coolant	5-cyl. manual gearbox	9.5	Coolant with corrosion inhibitor mixed with water, see packaging. The thermostat starts opening at 90 °C
	5-cyl. automatic gearbox	10.0	
	4-cyl. Diesel (2.0D)	9.5	
Air conditioning <sup>1</sup>		180–200 grams	Compressor oil PAG
		500–600 grams	Refrigerant R134a (HFC134a)
Brake fluid		0.6	DOT 4+
Power steering		1.0–1.2	Power steering fluid: WSS M2C204-A or equivalent product with same specifications.
Washer fluid	5-cyl. Petrol/5-cyl. Diesel	6.5	Use a washer antifreeze recommended by Volvo, mixed with water for temperatures below freezing.
Fuel tank	See page 242		

<sup>1</sup>Weights can vary depending on the engine variant. Contact an authorised Volvo workshop for the exact information.

# 11 Specifications

## Fuel

### Consumption, emissions and volume

Engine		Gearbox	Consumption litre/100 km	Emissions of carbon dioxide (CO <sub>2</sub> ) g/km	Tank volume (litres)
2.4	B5244S5	Manual 5-speed (M56)	8.9	212	62
		Automatic gearbox (AW55-50/51)	9.6	229	
2.4i	B5244S4	Manual 5-speed (M56)	9.0	215	
		Automatic gearbox (AW55-50/51)	9.6	229	
T5	B5254T7	Manual 6-speed (M66)	9.1	217	60
		Automatic gearbox (AW55-50/51)	9.8	234	
2.4D	D5244T8	Automatic gearbox (AW55-51)	7.3	193	
		Automatic gearbox (AW55-51)	7.3	193	
2.0D	D4204T (EURO3) (EURO4)	Manual 6 speed (MMT6)	6.1	161	52
			6.1	161	

### Fuel consumption and emissions of carbon dioxide

Official fuel consumption figures are based on a standard driving cycle in accordance with EU Directive 80/1268 comb. Fuel consumption figures may change if the car is equipped with extra equipment that affects the car's weight. The manner in which the car is driven and other non-technical factors can also affect fuel consumption. Consumption is higher and power output lower for fuel with an octane rating of 91 RON.



#### NOTE

Extreme weather conditions, towing a trailer or driving at high altitudes in combination with fuel grade are factors that could affect the car's performance.

### Petrol

Most engines can be run with octane ratings of 91, 95 and 98 RON.

- 91 RON must not be used for 4-cylinder engines and should only be used in exceptional cases with other engines.
- 95 RON can be used for normal driving.
- 98 RON is recommended for optimum performance and minimum fuel consumption.

When driving in temperatures above +38 °C, fuel with the highest possible octane rating is recommended for optimum performance and fuel economy.

Petrol – Norm EN 228.



#### IMPORTANT

Use only unleaded petrol to avoid damaging the catalytic converter. In order for the Volvo warranty to apply, never mix alcohol with petrol, the fuel system could be damaged.

### Diesel

Diesel must fulfil the EN 590 or JIS K2204 standards. The diesel engine fuel system is sensitive to contaminants, see page 181.

## Catalytic converter

### General

The purpose of the catalytic converter is to purify exhaust gases. It is located in the flow of exhaust gases close to the engine so that it quickly reaches operating temperature. The catalytic converter consists of a monolith (ceramic or metal) with channels. The channel walls are lined with a thin layer of platinum, rhodium and palladium. These metals act as catalysts, i.e. they participate in and accelerate a chemical reaction without being used up themselves.

### Lambda-sond™ oxygen sensor

The Lambda-sond is part of a control system intended to reduce emissions and improve fuel economy.

An oxygen sensor monitors the oxygen content of the exhaust gases leaving the engine. This value is fed into an electronic system that continuously controls the injectors. The ratio of air to fuel is continuously adjusted. These adjustments create optimal conditions for efficient combustion, and together with the three-way catalytic converter reduce harmful emissions (hydrocarbons, carbon monoxide and nitrous oxides).

## Electrical system

### General

12 volt system with a voltage-regulated alternator. Single pole system in which the chassis and engine block are used as conductors.

Voltage	12 V	12 V	12 V
Cold start capacity (CCA)	590 A	600 A <sup>1</sup>	700 A <sup>2</sup>
Reserve capacity (RC)	100 min	120 min	135 min
Capacity (Ah)	60	70	80

<sup>1</sup>Car equipped with High Performance audio system.

<sup>2</sup>Car equipped with diesel engine, Keyless drive, audio system Premium Sound, fuel-driven heater or RTI.

If the battery is changed, replace it with a battery of the same cold start capacity and reserve capacity as the original (see the decal on the battery).

# 11 Specifications

## Electrical system

### Bulbs

Lighting	Output W	Type
Dipped beam	55	H7
Main beam	55	HB3
Brake lights, reversing lamps, rear fog lamp	21	P21W
Direction indicators, rear/front	21	PY21W
Rear position/parking lamps, rear side marker lamps	4	P21/4W
Courtesy lighting, cargo area lighting, number plate lighting	5	C5W
Vanity mirror	1.2	Tubular lamp
Front position/parking lamps, front side marker lamps	5	W5W
Fog lamps	55	H11
Glovebox lighting	3	Tubular lamp

## Type approval

## Remote control system

Country	
A, B, CY, CZ, D, DK, E, EST, F, FIN, GB, GR, H, I, IRL, L, LT, LV, M, NL, P, PL, S, SK, SLO	 <sup>1</sup>
IS, LI, N, CH	
HR	
ROK	Delphi 2003-07-15, Germany R-LPD1-03-0151
BR	 <sup>2</sup> 
RC	 ETC093LPD0155

<sup>1</sup> Delphi hereby certifies that this remote control system conforms to the essential characteristic requirements and other relevant regulations of directive 1999/5/EG.

<sup>2</sup> USA-FCC ID: KR55WK48952, KR55WK48964

## NOTE:

This remote control system is in conformity with section 15 in the FCC Rules. The function refers to the following two conditions:

1. This system must not cause any harmful interference.
2. This system accepts interference received, including interference that affects the system negatively.

## Important!

Modifications to the system not approved by the manufacturer could lead to the remote control system ceasing to work.

Siemens VDO  
5WK48891

Tested to conform with FCC characteristic requirements for use in a passenger car.



## A

- 
- A/C
    - electronic climate control ..... 70
  - ABS ..... 128
    - ABS fault ..... 41
  - Active Yaw Control ..... 130
  - Additional heater ..... 73
  - Adjustment, clock ..... 61
  - AF – automatic frequency update ..... 214
  - Air conditioning ..... 66
    - ECC ..... 68
  - Air distribution ..... 71
    - ECC ..... 70
  - Air quality system, ECC ..... 69
  - Air vents ..... 67
  - Airbag
    - deactivation ..... 19
    - driver's and front passenger side ..... 16
  - Alarm
    - alarm light ..... 110
    - alarm signals ..... 111
    - arming ..... 110
    - automatic alarm activation ..... 111
    - deactivating a triggered alarm ..... 111
    - disarming ..... 110
    - general ..... 110
    - testing the alarm system ..... 113
  - Alarm, radio functions ..... 212
  - Approach light duration
    - active lamps ..... 59
    - setting ..... 62
  - Audio
    - steering wheel keypad ..... 53
  - Audio volume
    - audio system ..... 207
    - media player ..... 207
  - Audio, see also Sound ..... 207
  - AUTO
    - climate control settings ..... 68
    - preset storage ..... 211
  - AUTO CLIMATE ..... 68
  - Auto volume control ..... 209
  - Automatic car wash ..... 170
  - Automatic dimming ..... 57
  - Automatic gearbox ..... 127
    - safety systems ..... 126
    - towing and recovery ..... 138
    - trailer ..... 141, 142
  - Automatic locking ..... 108
  - Automatic relocking ..... 107
  - Autostart ..... 119
  - Average fuel consumption ..... 49
- 
- ## B
- Backrest
    - front seat, lowering ..... 77
  - Bass speaker ..... 209
  - Battery
    - care ..... 188
    - jump starting ..... 140
    - overload ..... 117
    - replacement ..... 189
    - replacing the battery in the remote
      - control ..... 105
      - symbols on the battery ..... 188
  - Blind spot (BLIS) ..... 135
  - Bonnet ..... 180
  - Boot lid
    - driving with open boot lid ..... 116
    - locking/unlocking ..... 97, 106
  - Boot lid, mechanical opening ..... 107
  - Brake fluid, checking and topping up ..... 185
  - Brake lights ..... 47
  - Brake system ..... 128, 185
  - Brakes
    - brake lights ..... 47
    - emergency brake light, EBL ..... 47
    - handbrake ..... 55
  - Bulb holder
    - location of the bulbs ..... 193
    - number plate lighting ..... 194
    - removal ..... 193
  - Bulbs
    - replacement ..... 190
    - specifications ..... 246

## C

- Call
  - functions during an ongoing call .....223
  - phone volume .....222
- Call waiting .....221
- Calls
  - making and receiving .....221
- Car care, leather upholstery .....172
- Car settings .....62
- Car upholstery .....172
- Car wash .....170
- Cargo area
  - electrical socket .....92
  - load retaining eyelets .....92
  - loading .....150
- Cargo separator .....90
- Catalytic converter .....244
  - recovery .....138
- CD discs
  - storage compartment .....87
- CD functions .....215
- Checks
  - fluids and oils .....179, 182
- Children
  - child seats and airbags .....28
  - child seats and side airbags .....20
  - position in car, table .....30
- safety equipment .....28
- Cigarette lighter socket
  - front seat .....45
- Clean inside and out .....8
- Cleaning
  - automatic car wash .....170
  - car wash .....170
  - seatbelts .....172
  - upholstery .....172
- Climate
  - personal preferences .....61
- Climate control .....66
- Climate control settings
  - AUTO .....68
- Clock, adjustment .....61
- Closing the roof .....80
- Clutch fluid, checking and topping up .....185
- Coat hanger .....87
- Collision
  - collision sensors .....22
  - crash mode .....27
  - IC .....22
  - inflatable curtain .....22
- Colour code, paint .....173
- Combined instrument panel .....39
- Compass .....57
  - calibration .....57
- Condensation .....181
- Control panel in driver's door
  - operation .....56
- Coolant, checking and topping up .....184
- Cooling system .....116
- Crash, see Collision .....22
- Cruise control .....52

## D

- Deadlocks .....109
  - temporary deactivation .....109
  - temporary disconnection of alarm
    - detectors .....112
- Designation of dimensions .....154
- Diesel .....181
  - engine preheater .....41
- Diesel filter .....181
- Diesel particle filter .....120
- Dimensions .....233
- Dipped beam .....46, 48
- Direction indicators .....48
- Disc text .....216
- Display
  - messages .....43, 44
- Display lighting .....46
- Dolby Surround Pro Logic II .....206, 209
- Door mirror, position memory .....59
- Door mirrors .....59

- Driver's door control panel .....38
- Driving
- adverse driving conditions ..... 178
  - cooling system ..... 116
  - economical ..... 116
  - slippery driving conditions ..... 116
  - with open boot lid ..... 116
  - with trailer ..... 141
- Driving in water ..... 116
- DSTC, see also Stability system
- deactivating/activating ..... 130
  - symbol ..... 41
- E**
- 
- Easy entry ..... 76
- ECC ..... 66
- ECC, electronic climate control ..... 67
- ECO pressure
- fuel economy ..... 158
  - table ..... 159
- Economical driving ..... 116
- Electrical socket
- cargo area ..... 92
  - centre console ..... 45
- Electronic immobiliser ..... 96
- Emergency calls ..... 219
- Emission control ..... 7
- Emissions ..... 242
- carbon dioxide ..... 243
- Emissions system
- fault indicator ..... 41
- Engine ..... 180
- Engine compartment ..... 180
- Engine oil ..... 182
- capacities ..... 238, 239, 240
  - changing ..... 182
  - driving under adverse driving conditions ..... 237
  - filter ..... 182
  - oil grade ..... 237
  - oil pressure ..... 42
- Engine specifications ..... 235
- Entry, keyless ..... 62
- Environmental philosophy ..... 7
- EON – Enhanced Other Networks ..... 214
- Equalizer ..... 209
- Expectant mothers
- safety ..... 13
- F**
- 
- Fan
- ECC ..... 68
- Fast-wind ..... 216
- First aid ..... 87
- Floor mats ..... 77
- Fluids and oils
- checks ..... 179, 182
- Fluids, capacities ..... 241
- Fog lamps
- on/off ..... 47
- Frequency update, automatic ..... 214
- Front seats
- easy entry ..... 76
  - lowering ..... 76
  - seating position ..... 76
- Fuel
- consumption ..... 7, 242
  - fuel consumption, display ..... 49
  - fuel economy ..... 158
  - fuel filter ..... 181
  - fuel system ..... 181
  - level indicator ..... 41
  - parking heater ..... 73
  - refuelling ..... 118
- Fuel gauge ..... 39
- Fuse table
- fuses in the engine compartment ..... 198
  - fuses in the passenger compartment .. 201
- Fuses
- changing ..... 196
  - general ..... 196
  - relay/fuse box in the engine compartment ..... 197
  - relay/fuse box in the passenger compartment ..... 200

**G**

---

- Gearbox
  - automatic ..... 127
  - manual ..... 123
- Global opening ..... 106
- Glovebox ..... 87
  - locking ..... 101
- Gross vehicle weight ..... 234

**H**

---

- Handbrake ..... 55
- Hanging light garments ..... 87
- Hatch cover ..... 80
- Hatch for long loads ..... 92
- Hazard warning flashers ..... 54
- Headlamp pattern ..... 151
- Headlamps
  - headlamp washers ..... 50
  - Off/On ..... 46
- Heating
  - front seats ..... 70
- Homesafe light duration ..... 48, 59
  - setting ..... 62

**I**

---

- IDIS ..... 219
- Ignition keys ..... 121

- IMEI number ..... 224
- Immobiliser ..... 96, 121
- "Important!" texts ..... 6
- Incoming calls ..... 221
- Information display ..... 43
- Infotainment
  - menus ..... 206
- Instrument lighting ..... 46, 47
- Instrument overview
  - left-hand drive ..... 34, 218
  - right-hand drive ..... 36
- Interior lighting ..... 84
- Interior rearview mirror ..... 57
- Intermittent wiping ..... 50
- ISOFIX
  - fixture system ..... 31

**J**

---

- Jack ..... 160
- Jump starting ..... 140

**K**

---

- Kerb weight ..... 234
- Key ..... 97
  - keyless lock and ignition system ..... 102
  - remote control ..... 96
- Key blade
  - active locks ..... 99

- Keyless drive ..... 102
  - starting the car ..... 122
- Keyless entry ..... 62
- Kick-down
  - automatic gearbox ..... 126

**L**

---

- Lambda-sond ..... 244
- Leather upholstery, washing instructions ..... 172
- Lighting ..... 84
  - automatic lighting, dipped beam ..... 46
  - automatic lighting, passenger compartment ..... 84
  - bulb replacement, general ..... 190
  - bulbs, specifications ..... 246
  - dipped beam ..... 46
  - display lighting ..... 46
  - exterior ..... 46
  - front fog lamps ..... 47
  - headlamp levelling ..... 46
  - homesafe light duration ..... 48, 59
  - instrument lighting ..... 46
  - lighting panel ..... 46
  - main/dipped beam ..... 48
  - position/parking lamps ..... 46
  - rear fog lamp ..... 47
  - rear seat ..... 84

- Lighting, bulb replacement
- cargo area ..... 194
  - courtesy lighting ..... 194
  - dipped beam ..... 191
  - direction indicators ..... 192
  - fog lamp ..... 193
  - front ..... 190
  - location of the bulbs in the bulb holder ..... 193
  - main beam ..... 191
  - parking lamps ..... 192
  - position lamps ..... 192
  - rear lamp ..... 193
  - side marker lamps ..... 192
  - vanity mirror ..... 195
- Lights
- main beam "flash" ..... 48
- Loading
- cargo area ..... 92
  - general ..... 150
  - load capacity ..... 150
- Loading assistance ..... 90
- Loading, error messages ..... 81
- Locking ..... 106
- from inside ..... 108
  - from outside ..... 106
  - unlocking ..... 106
- Long loads ..... 92
- Lowering, roof ..... 79
- Lubricants, capacities ..... 241
- M**
- 
- Main beam ..... 48
- Off/On ..... 46
  - switching and flashing ..... 48
- Maintenance
- rustproofing ..... 174
  - self-maintenance ..... 179
- Making calls ..... 221
- Manual gearbox ..... 123
- Menu structure
- media player ..... 217
  - phone, menu options ..... 226
  - phone, overview ..... 225
- Menus
- audio system ..... 206
- Messages in the information display ..... 43
- Misting
- removing with defroster function ..... 69
  - timer function, ECC ..... 69
  - treating the windows ..... 66
- N**
- 
- NEWS ..... 213
- News broadcast ..... 213
- "Note" texts ..... 6
- O**
- 
- Oil, see also Engine oil
- oil pressure ..... 42
- Opening the roof ..... 80
- Outside temperature gauge ..... 39
- Oxyhydrogen gas ..... 140
- P**
- 
- PACOS ..... 18
- Paint
- paintwork damage and touching up .... 173
- Paintwork
- colour code ..... 173
- Panels, lighting ..... 84
- Parking assistance ..... 132
- sensors for parking assistance ..... 134
- Parking brake ..... 42, 55
- Parking heater
- battery and fuel ..... 73
  - general ..... 72
  - parking on a hill ..... 72
  - time setting ..... 73
- Parking lamps ..... 46
- Passenger compartment filter ..... 66
- Personal preferences ..... 61
- approach light duration ..... 62
  - auto blower adjust ..... 61

automatic locking .....	62
doors unlock .....	62
homesafe light duration .....	62
keyless entry .....	62
lock confirm, light .....	62
recirculation timer .....	61
unlock confirm, light .....	62
Petrol grade .....	243
Phone .....	220
calling from the phone book .....	223
On/Off .....	221
standby mode .....	221
steering wheel keypad .....	53
text input .....	222
Phone book .....	
handling numbers .....	222
Phone system .....	218
PI seek .....	214
Polishing .....	171
Position lamps .....	46
Power seat .....	77
Power steering fluid, checking and topping up .....	186
Power windows .....	56
Privacy locking .....	100
Programme functions .....	212
PTY – Programme type .....	213
Putting calls on hold .....	221

## R

Radio .....	
radio settings .....	211
radio stations .....	211
Radio text .....	214
Rain sensor .....	51
Random, CD and audio files .....	216
RDS functions .....	212
resetting .....	214
Rearview mirrors .....	
compass .....	57
door .....	59
electrically retractable .....	59
interior .....	57
Recirculation .....	
ECC .....	69
Recovery .....	138
Refrigerant .....	66
Refuelling .....	
fuel cap .....	118
refuelling .....	118
Refuse calls .....	221
REG – Regional radio programmes .....	214
Relay/fuse box .....	
in the engine compartment .....	197
in the passenger compartment .....	200

Remote control .....	96
functions .....	97
keyless drive .....	102
replacing the battery .....	105
Remote control system, type approval .....	247
Reverse gear inhibitor .....	
five-speed .....	123
six-speed, petrol .....	124
Roof, lowering .....	79
Rustproofing .....	174

## S

Safety .....	12
safety systems, table .....	26
SCAN .....	
CD and audio files .....	216
radio stations .....	212
Seat .....	
power seat .....	77
Seatbelt .....	12
pregnancy .....	13
rear seat .....	13
Seatbelt reminder .....	13
Seats .....	
lowering the front backrest .....	77
manual setting .....	76
Service programme .....	178
Settings, see Personal preferences .....	61

Side airbags .....	20	Starting from cold	
SIM card .....	219	automatic gearbox .....	127
SIPS bags .....	20	Starting the engine .....	119
Ski hatch .....	92	keyless drive .....	122
SMS		STC .....	130
read .....	224	Steering lock .....	121
write .....	224	Steering wheel	
Soot filter .....	44, 120	adjustment .....	54
SOOT FILTER FULL .....	120	cruise control .....	52
Sound		keypad .....	220
audio settings .....	207	keypad left-hand side .....	52
audio source .....	207	keypad right-hand side .....	53
Spare wheel .....	160	Steering wheel keypad	
Temporary spare .....	156	phone/audio .....	53
Speed classes, tyres .....	154	Stone chips and scratches .....	173
Speed dial .....	223	Storage compartment .....	86
Speedometer .....	39	CD discs .....	87
Spin Control .....	130	rear side panels .....	87
SRS system		Storage spaces in the passenger	
general .....	17	compartment .....	86
switch .....	19	Storing stations, manual and automatic ...	211
Stability control system .....	130	Subwoofer .....	209
Stability system		Surround .....	206, 209
indication .....	41	Symbols .....	131
Stains .....	172	indicator symbols .....	41
Standby mode, phone .....	221	warning symbols .....	40

<b>T</b>	
Tachometer .....	39
Tank volume .....	242
Temperature	
actual temperature .....	67
passenger compartment, electronic	
climate control .....	70
Ticket clip .....	87
Timer	
ECC .....	69
Towbar, see Towing equipment .....	143
Towing .....	138
Towing equipment	
general .....	143
installation .....	145
removing .....	148
specifications .....	144
Towing eye .....	139
TP – traffic information .....	212
Traction control system .....	130
Traffic information .....	212
Trailer	
cable .....	143
driving with a trailer .....	141
trailer weight .....	234
Trip computer .....	49

Trip meter .....	39
Tuning .....	211
Type approval, remote control system .....	247
Type designation .....	232
Tyre	
pressure .....	158
Tyres	
designation of dimensions .....	154
direction of rotation .....	157
driving characteristics .....	154
ECO pressure .....	159
general .....	154
speed classes .....	154
summer and winter wheels .....	157
tread wear indicators .....	155
winter tyres .....	155

## U

Unlocking	
boot lid .....	106
from inside .....	108
from outside .....	106
keyless .....	106
settings .....	62

## V

Vehicle data .....	178
Ventilation .....	67

Volume	
auto volume control .....	209
phone/media player .....	222
programme types .....	214
Volume, see also Audio volume .....	207

## W

Warning lamp	
stability and traction control system ...	130
Warning symbol, airbag system .....	15
"Warning!" texts .....	6
Warning triangle .....	160
Washer fluid, topping up .....	184
Washers	
windscreen and headlamps .....	50
Washing the car .....	170
Waxing .....	171
Wheels	
fitting .....	163
removal .....	162
rims .....	156
Whiplash injury WHIPS .....	23
WHIPS .....	23
child seat/booster cushion .....	23
Wind deflector .....	83
Windscreen wipers	
rain sensor .....	51

Windscreen wipers and washers .....	50
Winter driving .....	120
Winter tyres .....	155
Wiper blades	
replacement .....	187



Volvo. for life

**VOLVO**

Volvo Car Corporation TP 9198 (English), AT 0720, Printed in Sweden, Göteborg 2007, Copyright © 2000-2007 Volvo Car Corporation

Download from [Www.Somanuals.com](http://www.somanuals.com). All Manuals Search And Download.

## Free Manuals Download Website

<http://myh66.com>

<http://usermanuals.us>

<http://www.somanuals.com>

<http://www.4manuals.cc>

<http://www.manual-lib.com>

<http://www.404manual.com>

<http://www.luxmanual.com>

<http://aubethermostatmanual.com>

Golf course search by state

<http://golfingnear.com>

Email search by domain

<http://emailbydomain.com>

Auto manuals search

<http://auto.somanuals.com>

TV manuals search

<http://tv.somanuals.com>