



VOLVO C30

OWNER'S MANUAL



WEB EDITION

DEAR VOLVO OWNER

THANK YOU FOR CHOOSING VOLVO

We hope you will enjoy many years of driving pleasure in your Volvo. The car has been designed for the safety and comfort of you and your passengers. Volvo is one of the safest cars in the world. Your Volvo has also been designed to satisfy all current safety and environmental requirements.

In order to increase your enjoyment of the car, we recommend that you familiarise yourself with the equipment, instructions and maintenance information contained in this Owner's Manual.





00 Introduction

| | |
|---|---|
| Introduction | 6 |
| Volvo Car Corporation and the environment | 7 |



01 Safety

| | |
|--|----|
| Seatbelts | 12 |
| Airbag system | 15 |
| Airbags (SRS) | 16 |
| Activating/deactivating the airbag (SRS) | 19 |
| Side airbags (SIPS bags) | 21 |
| Inflatable Curtain (IC) | 23 |
| WHIPS | 24 |
| When the systems deploy | 26 |
| Crash mode | 27 |
| Child safety | 28 |

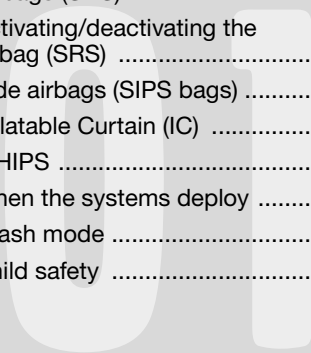

02 Instruments and controls

| | |
|--|----|
| Overview, left-hand drive car | 34 |
| Overview, right-hand drive car | 36 |
| Driver's door control panel | 38 |
| Combined instrument panel | 39 |
| Indicator and warning symbols | 40 |
| Information display | 43 |
| Electrical socket and switch, centre console | 45 |
| Lighting panel | 46 |
| Left-hand stalk switch | 48 |
| Right-hand stalk switch | 50 |
| Cruise control (option) | 52 |
| Steering wheel keypad (option) | 54 |
| Steering wheel adjustment, hazard warning flashers | 55 |
| Parking brake, electrical socket | 56 |
| Power windows | 57 |
| Rearview and door mirrors | 59 |
| Power sunroof (option) | 62 |
| Personal preferences | 64 |

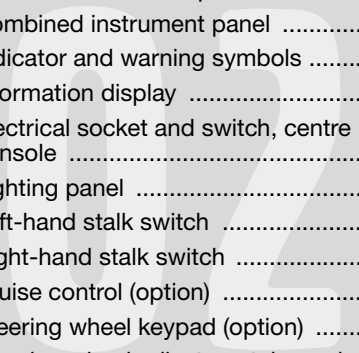



03 Climate control

| | |
|--|----|
| General information on climate control | 68 |
| Manual climate control, A/C | 70 |
| Electronic climate control, ECC (option) | 72 |
| Air distribution | 75 |
| Fuel-driven heater (option) | 76 |



04 Interior

| | |
|---|----|
| Front seats | 80 |
| Interior lighting | 82 |
| Storage spaces in the passenger compartment | 84 |
| Rear seat | 86 |
| Cargo area | 87 |



05 Locks and alarm

| | |
|-------------------------------------|-----|
| Remote control with key blade | 94 |
| Keyless drive (option) | 98 |
| Locking and unlocking | 100 |
| Alarm (option) | 103 |



06 Starting and driving

| | |
|---|-----|
| General | 108 |
| Refuelling | 110 |
| Starting the engine | 111 |
| Keyless drive (option) | 113 |
| Manual gearbox | 114 |
| Automatic gearbox | 116 |
| Brake system | 119 |
| Stability and traction control system | 121 |
| Parking assistance (option) | 123 |
| Blind Spot Information System BLIS (option) | 125 |
| Towing and recovery | 128 |
| Jump starting | 130 |
| Driving with a trailer | 131 |
| Towing bracket | 133 |
| Detachable towbar | 135 |
| Loading | 140 |
| Adjusting headlamp pattern | 141 |



07 Wheels and tyres

| | |
|-------------------------------------|-----|
| General | 144 |
| Tyre pressure | 148 |
| Warning triangle and spare wheel .. | 150 |
| Changing wheels | 151 |
| Emergency puncture repair | 153 |



08 Car care

| | |
|-----------------------------|-----|
| Cleaning | 162 |
| Touching up paintwork | 165 |
| Rustproofing | 166 |



09 Maintenance and service

| | |
|----------------------------------|-----|
| Volvo service | 170 |
| Self-maintenance | 171 |
| Bonnet and engine compartment .. | 172 |
| Diesel | 173 |
| Oils and fluids | 174 |
| Wiper blades | 178 |
| Battery | 179 |
| Replacing bulbs | 181 |
| Fuses | 187 |



10 Infotainment system

| | |
|-------------------------------------|-----|
| General | 196 |
| Audio functions | 197 |
| Radio functions | 199 |
| CD functions | 203 |
| Menu structure – audio system | 205 |
| Phone functions (option) | 206 |
| Menu structure – phone | 213 |



11 Specifications

| | |
|------------------------------|-----|
| Type designation | 220 |
| Dimensions and weights | 221 |
| Engine specifications | 224 |
| Engine oil | 226 |
| Fluids and lubricants | 230 |
| Fuel | 232 |
| Catalytic converter | 234 |
| Electrical system | 235 |



Introduction

Owner's Manual

A good way of getting to know your new car is to read the Owner's Manual, ideally before your first journey. This will give you the opportunity to familiarise yourself with new functions, to see how best to handle the car in different situations, and to make the best use of all the car's features. Please pay attention to the safety instructions contained in the manual.



WARNING

"Warning" texts indicate where there is a risk of personal injury in the event of the instructions not being followed.



IMPORTANT

"Important" texts indicate a risk of damage to the car in the event of the instructions not being followed.

The equipment described in the owner's manual is not present in all models. In addition to standard equipment, this manual also describes options (factory fitted equipment) and certain accessories (extra equipment).



NOTE

Volvo cars are adapted for the varying requirements of different markets, as well as for national or local legal requirements and regulations.

The specifications, design features and illustrations in this owner's manual are not binding. We reserve the right to make modifications without prior notice.

© Volvo Car Corporation

Volvo Car Corporation and the environment

Volvo Cars' environmental philosophy



Environmental care, safety and quality are the three core values which influence all operations of the Volvo Car Corporation. We also believe that our customers share our consideration for the environment.

Your Volvo complies with strict international environmental standards and is also manufactured in one of the cleanest and most resource-efficient plants in the world. Volvo Car Corporation has global certification to the ISO 14001 environmental standard. This standard supports the work within the area of the environment.

EPI (Environmental Product Information) is supplied for all Volvo models. There you can see how the car's lifecycle affects the environment.

Read more at www.volvocars.com/EPI.

Fuel consumption

Volvo cars have competitive fuel consumption in each of their respective classes. Lower fuel consumption generally results in lower emission of the greenhouse gas, carbon dioxide.

It is possible for the driver to influence fuel consumption. For more information read under the heading, Reducing environmental impact, on page 9.



Volvo Car Corporation and the environment

Efficient emission control

Your Volvo is manufactured following the concept **Clean inside and out** – a concept that encompasses a clean interior environment as well as highly efficient emission control. In many cases the exhaust emissions are well below the applicable standards.

In addition there is a special radiator coating, PremAir®¹, which can convert hazardous ground-level ozone into pure oxygen when the ozone passes the radiator. The higher the ozone content of the air the more ozone is converted.

¹ Option for 5-cylinder engines. (Certain markets)

PremAir® is a registered trademark of Engelhard Corporation.

Clean air in the passenger compartment

A passenger compartment filter prevents dust and pollen from entering the passenger compartment via the air intake.

A sophisticated air quality system, IAQS² (Interior Air Quality System) ensures that the incoming air is cleaner than the air in the traffic outside.

The system consists of an electronic sensor and a carbon filter. The incoming air is monitored continuously and if there is an increase in the level of certain unhealthy gases such as carbon monoxide then the air intake is closed. Such a situation may arise in heavy traffic, queues and tunnels for example.

The entry of nitrous oxides, ground-level ozone and hydrocarbons is prevented by the carbon filter.

Textile standard

The interior of a Volvo is designed to be pleasant and comfortable, even for people with contact allergies and for asthma sufferers. All of our upholstery and interior textiles are tested with respect to certain unhealthy substances and allergens as well as emissions. This means that all textiles fulfil the re-

² Option

quirements in the Öko-Tex 100³ standard, a major advance towards a healthier passenger compartment environment.

Öko-Tex certification covers seatbelts, carpets, thread and fabrics for example. The leather in the upholstery undergoes chromium-free tanning with natural plant substances and fulfils the certification requirements.

Volvo workshops and the environment

Regular maintenance creates the conditions for long service life for the car and low fuel consumption, and this way you contribute to a cleaner environment. When Volvo's workshops are entrusted with the repair and maintenance of the car, it becomes part of our system. We make clear demands regarding the way in which our workshops are designed in order to prevent spills and discharges into the environment. Our workshop staff have the knowledge and the tools required to guarantee good environmental care.

³ More information on www.oekotex.com

Reducing environmental impact

You can help reduce environmental impact, for example, by driving economically, by purchasing eco-labelled car care products and by servicing and maintaining the car according to the instructions in the owner's manual.

The following hints will help you to do your bit for the environment:

- Decrease fuel consumption by choosing ECO tyre pressure, see page 148.
- A roof load and ski box increase air resistance, leading to significantly higher fuel consumption. Remove them immediately after use.
- Remove unnecessary items from the car. The greater the load the higher the fuel consumption.
- If the car is equipped with an engine block heater use it for a few hours before starting from cold. This reduces fuel consumption and exhaust emissions.
- Drive gently and avoid braking too hard.
- Drive in the highest gear possible. Low engine speeds result in lower fuel consumption.
- Ease back on the accelerator on downhill gradients.



- Use engine braking to slow down.
- Avoid idling. Take consideration of local regulations. Switch off the engine in traffic queues.
- Always dispose of environmentally hazardous waste, such as batteries and oils, in an environmentally safe manner. If uncertain about disposal, consult an authorised Volvo workshop for advice.
- Service your car regularly.

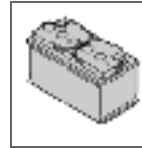

These hints will help you reduce fuel consumption without increasing travel time or lessening the enjoyment of driving. Apart from being kind to your car, you'll be saving money - and the Earth's resources.

| | |
|--|----|
| Seatbelts | 12 |
| Airbag system | 15 |
| Airbags (SRS) | 16 |
| Activating/deactivating the airbag (SRS) | 19 |
| Side airbags (SIPS bags) | 21 |
| Inflatable Curtain (IC) | 23 |
| WHIPS | 24 |
| When the systems deploy | 26 |
| Crash mode | 27 |
| Child safety | 28 |

SAFETY



01



Seatbelts

Always use a seatbelt



Tensioning the hip strap. The belt must be positioned low down.

Heavy braking can have serious consequences if the seatbelts are not used. Ensure that all passengers use their seatbelts.

Putting on a seatbelt:

- Pull the belt out slowly and secure it by pressing the buckle into the lock. A loud "click" indicates that the belt has locked.

Releasing the belt

- Press the red lock button and then let the belt retract. If the belt does not retract fully, feed it in by hand so that it does not hang loose.

The belt locks and cannot be withdrawn

- if it is pulled out too quickly
- during braking and acceleration
- if the car leans heavily.

It is important that the belt lies in contact against the body so it can provide maximum protection. Do not lean the backrest too far back. The belt is designed to protect in a normal seating position.

Keep in mind the following:

- do not use clips or anything else that can prevent the belt from fitting properly
- ensure the belt is not twisted or caught on anything
- the hip strap must be positioned low down (not over the abdomen)
- tension the hip strap over the lap by pulling the diagonal shoulder belt as illustrated

WARNING

The seatbelts and airbags interact. If a seatbelt is not used or is used incorrectly, this may diminish the protection provided by the airbag in the event of a collision.

WARNING

Each belt is intended for one person only.

WARNING

Never modify or repair the belt yourself. Contact an authorised Volvo workshop. If the belt has been subjected to a major load, such as in a collision, the entire belt must be replaced. Some of the protective characteristics of the belt may have been lost, even if it appears to be undamaged. In addition, replace the belt if it is worn or damaged. The new seatbelt must be type-approved and intended for installation in the same position as the replaced belt.

WARNING

The rear seat is designed for a maximum of two passengers.



Seatbelt reminder

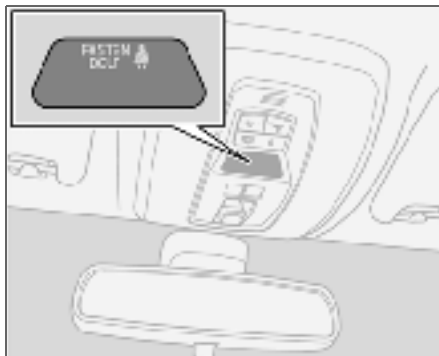

An audio signal and indicator lamp remind anyone not wearing a seatbelt to use one. The audio reminder is speed-dependent. Reminder indicator lamps are located in the roof console and combined instrument panel. At low speed, the audio reminder will sound for the first six seconds.

Child seats are not covered by the seatbelt reminder system.

Rear seat

The seatbelt reminder in the rear seat has two subfunctions:

- Provides information on which seatbelts are being used in the rear seat. This is

shown on the information display. The message is automatically cleared after approx. 30 seconds or can be acknowledged manually by pressing the **READ** button.

- Provides a warning if one of the rear seatbelts is unfastened during a journey. This warning takes the form of a message on the information display along with the audio/visual signal. The warning ceases when the belt is re-fastened or can be acknowledged manually by pressing the **READ** button.

The message on the information display showing which belts are in use is always available. Press the **READ** button to see stored messages.

Certain markets

An audio signal and indicator lamp remind the driver if not wearing a seatbelt to use one. At low speed, the audio reminder will sound for the first six seconds.

Seatbelts and pregnancy



The seatbelt should always be worn during pregnancy. But it is crucial that it be worn in the correct way. The diagonal section should wrap over the shoulder then be routed between the breasts and to the side of the abdomen. The lap section should lay flat over the thighs and as low as possible under the abdomen. It must never be allowed to ride upward. Remove all slack from the belt and ensure that it fits close to the body. In addition, check that there are no twists in the belt.

As a pregnancy progresses, pregnant drivers should adjust their seats and steering wheel such that they can easily maintain control of



Seatbelts

the vehicle as they drive (which means they must be able to easily operate the foot pedals and steering wheel). Within this context, they should strive to position the seat with as large a distance as possible between their abdomen and the steering wheel.

Seatbelt tensioner

All the seatbelts are equipped with belt tensioners. A mechanism in the belt tensioner tightens the belt around the body in the event of a sufficiently forceful collision. This provides more effective restraint by the belt for passengers.

Seatbelt guide

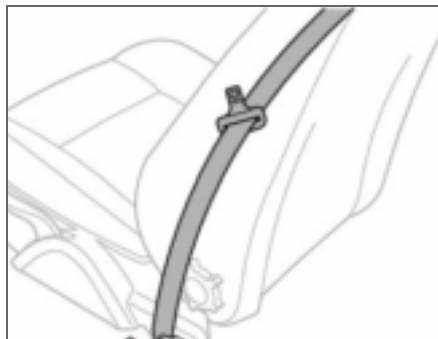

The seatbelt guide is fitted on both the driver's seat and passenger seat.

The seatbelt guide is an aid for providing better access to the seatbelt. When getting into and out of the rear seat the seatbelt is removed from the seatbelt guide and positioned furthest back on the seatbelt bar.



Warning symbol on the combined instrument panel

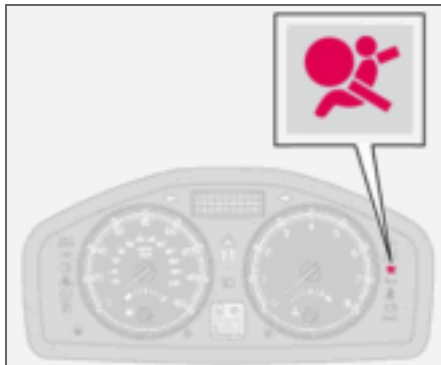

The airbag system¹ is continually monitored by the system's control module. The warning symbol on the combined instrument panel illuminates when the ignition key is turned to position **I**, **II** or **III**. The symbol goes out after approx. seven seconds provided the airbag system¹ is fault-free.



As well as the warning symbol, a message may appear on the information display in some cases. If the warning symbol malfunctions, the warning triangle illuminates and the message **SRS AIRBAG SERVICE URGENT** appears in the information display. Contact an authorised Volvo workshop immediately.

WARNING

If the warning symbol for the airbag system remains on or illuminates while driving, it means that the airbag system is not functioning fully. The symbol can indicate a fault in the seatbelt buckle, SIPS, SRS or IC systems. Contact an authorised Volvo workshop immediately.

¹Includes SRS and seatbelt tensioner, SIPS and IC.



Airbags (SRS)

Airbag (SRS) on the driver's side



The car has an SRS airbag (Supplemental Restraint System) in the steering wheel to supplement the protection afforded by the seatbelt. This airbag is fitted into the centre of the steering wheel. The steering wheel is marked **SRS AIRBAG**.

WARNING

The seatbelts and airbags interact. If a seatbelt is not used or is used incorrectly, this may diminish the protection provided by the airbag in the event of a collision.

Passenger airbag (SRS)

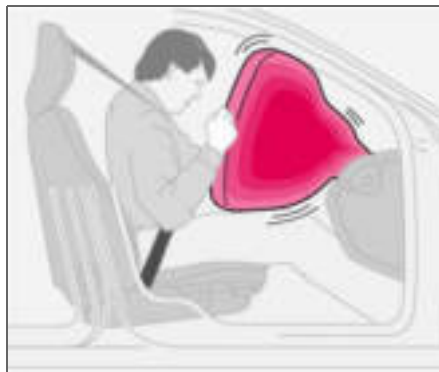

The car has an SRS airbag (Supplemental Restraint System) to supplement the protection afforded by the seatbelt. The passenger airbag¹ is fitted behind a panel above the glovebox. This panel is marked **SRS AIRBAG**.

¹ Not all cars have a passenger airbag (SRS). This can be unselected when the car is ordered.

WARNING

To minimise the risk of injury if the airbag deploys, passengers must sit as upright as possible with their feet on the floor and back against the backrest. Seatbelts must be secured.

WARNING

Never place a child in a child seat or on a booster cushion in the front seat if the airbag (SRS) is activated¹.

Never allow a child to stand or sit in front of the front passenger seat. No one shorter than 140 cm should ever sit in the front passenger seat if the airbag (SRS) is activated.

Failure to follow the advice given above can endanger the life of the child.

¹ For information on activated/deactivated airbag (SRS) see page 19.



Airbags (SRS)

SRS system

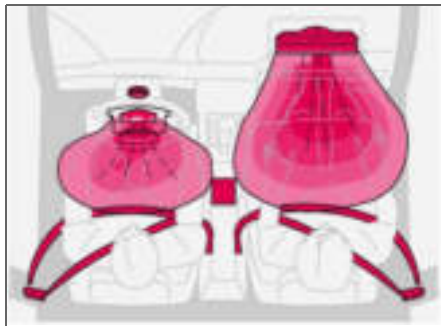

SRS system, left-hand drive.

The system consists of airbags and sensors. A sufficiently violent collision trips the sensors and the airbag(s) are inflated with hot gas. To cushion the impact, the airbag deflates when compressed. When this occurs, smoke escapes into the car. This is completely normal. The entire process, including inflation and deflation of the airbag, occurs within tenths of a second.

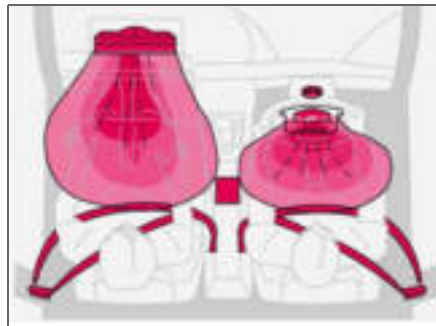

SRS system, right-hand drive.

NOTE

The sensors react differently depending on the course of the collision and whether or not the seatbelts on the driver and passenger side are used. It is therefore possible that only one (or none) of the airbags may inflate in a collision. The SRS system senses the force of the collision on the car and adapts accordingly so that one or more airbags are deployed.

NOTE

The airbags have a function whereby their capacities are adapted to the collision force to which the car is subjected.

WARNING

Any repair must only be performed by an authorised Volvo workshop. Any interference in the SRS system could cause malfunction and result in serious personal injury.



Airbags (SRS)

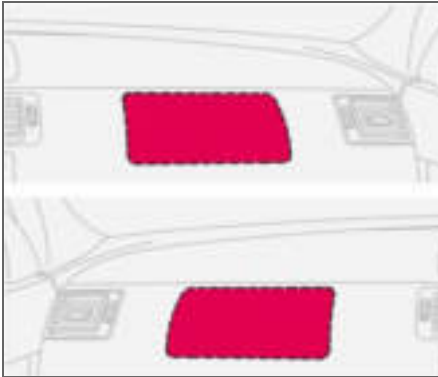

Location of the passenger airbag in left-hand drive and right-hand drive cars

WARNING

Never interfere with SRS components in the steering wheel or the panel above the glovebox.

Objects and accessories must not be positioned or glued on or near the **SRS AIR-BAG** panel (above the glovebox) or in the area affected by a deployed airbag.



Activating/deactivating the airbag (SRS)

PACOS (option)

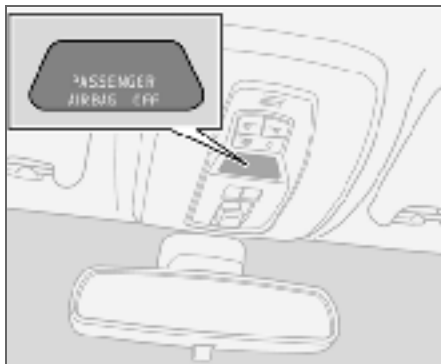

Indicator showing that the passenger airbag (SRS) is deactivated.

The airbag (SRS) for the front passenger seat can be deactivated using a switch. This is necessary if a child seat is to be fitted there for example.

Indicator

A text message on the roof panel indicates that the front passenger airbag (SRS) is deactivated.

Activating/deactivating

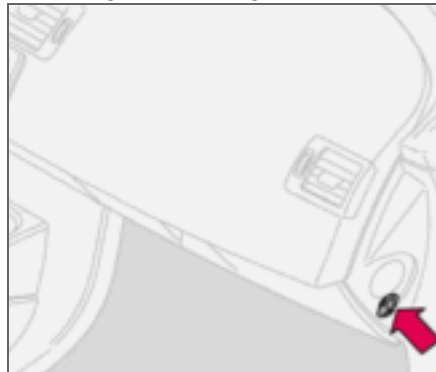

Switch for PACOS (Passenger Airbag Cut Off Switch).

The switch is located on the passenger end of the dashboard and is accessible when the passenger door is open. Check that the switch is in the required position. Volvo recommends that the ignition key is used to change position. (Other items with a shape similar to a key can be used).

WARNING

If the car is equipped with a front passenger airbag (SRS), but does not have PACOS, the airbag will always be activated.

WARNING

Activated airbag (passenger seat): Never place a child in a child seat or on a booster cushion in the front passenger seat when the airbag is activated. This applies to everyone shorter than 140 cm.

Deactivated airbag (passenger seat): No one taller than 140 cm should ever sit in the front passenger seat when the airbag is deactivated.

Failure to follow the advice given above can endanger life.



Activating/deactivating the airbag (SRS)

Switch position



Switch for SRS in ON position.

ON = Airbag (SRS) activated. With the switch in this position, persons taller than 140 cm can sit in the front passenger seat, although never children in a child seat or on a booster cushion.



Switch for SRS in OFF position.

OFF = Airbag (SRS) deactivated. With the switch in this position, children in a child seat or on a booster cushion can sit in the front passenger seat, although never persons taller than 140 cm.

WARNING

Do not allow anyone to sit in the front passenger seat if the text message in the roof panel indicates that the airbag (SRS) is deactivated and if the warning symbol for the airbag system is also displayed on the combined instrument panel. This indicates that there has been a severe malfunction. Contact an authorised Volvo workshop immediately.



Side airbags (SIPS bags)

Side airbags – SIPS bags



Side airbag locations.

A large proportion of the collision force is transferred by the SIPS (Side Impact Protection System) to beams, pillars, the floor, the roof and other structural parts of the body. The side airbags at the driver's and front passenger seats protect the chest area and are an important part of the SIPS. The side airbags are located in the front seat backrests.



Inflated side airbag.

WARNING

Side airbags are a supplement to the SIPS system. Always use a seatbelt.

WARNING

Any repair must only be performed by an authorised Volvo workshop.

Any interference in the SIPS system could cause malfunction and result in serious personal injury.

WARNING

Do not put objects in the area between the outside of the seat and the door panel, since this area is required by the side airbag.

WARNING

Use only Volvo genuine car seat covers, or seat covers approved by Volvo. Other seat covers may impede the operation of the side airbags.

Child seats and side airbags

The side airbag does not diminish the protection provided by the car to children seated in a child seat or on a booster cushion.

A child seat or booster cushion can be placed on the front passenger seat provided that the car does not have an activated¹ passenger airbag.

¹ For information on activated/deactivated airbag (SRS) see page 19



Side airbags (SIPS bags)

SIPS bags



Driver's side



Passenger side

The SIPS bag system consists of side airbags and sensors. A sufficiently violent collision trips the sensors and the side airbag is inflated. The airbag inflates between the occupant and the door panel and thereby cushions the initial impact while deflating. The side airbag is only normally deployed on the side of the collision.



Inflatable Curtain (IC)

01

Properties

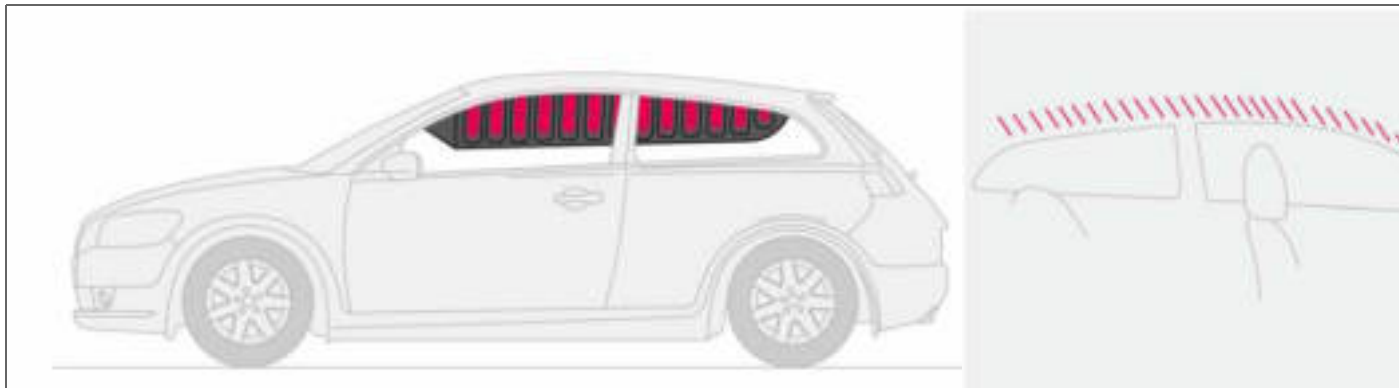

The inflatable curtain, IC (Inflatable Curtain), is a supplement to the SIPS system. It is fitted in the headlining along both sides of the roof and protects both front and rear seat passengers. A sufficiently violent collision trips the sensors and the inflatable curtain is inflated. The inflatable curtain helps to prevent the driver and front seat passenger from striking their heads on the inside of the car during a collision.

WARNING

Never hang or attach heavy items onto the handles in the roof. The hook is only designed for light clothing (not for solid objects such as umbrellas for example).

Do not screw or install anything onto the car's headlining, door pillars or side panels. This could compromise the intended protection. Only ever use Volvo genuine parts that are approved for placement in these areas.

WARNING

Do not load the car higher than 50 mm under the top edge of the side windows. Otherwise, the intended protection of the inflatable curtain, which is concealed in the headlining, may be compromised.

WARNING

The inflatable curtain is a supplement to the seatbelts.
Always use a seatbelt.



WHIPS

Protection against whiplash injury – WHIPS

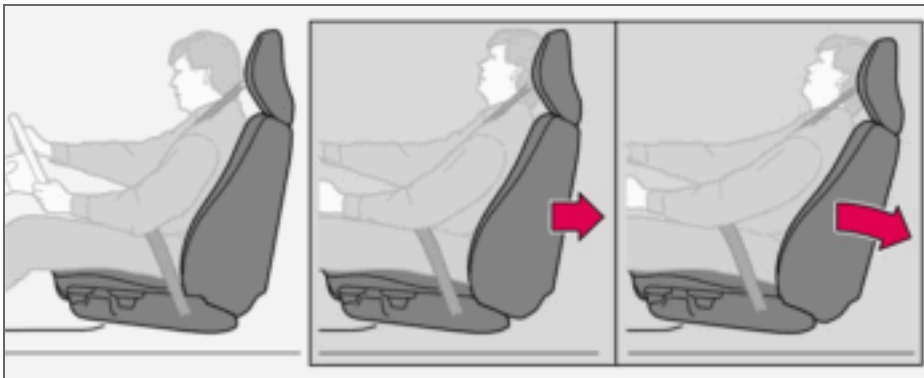

The whiplash protection system (WHIPS) consists of energy absorbing backrests and specially designed head restraints for the front seats. The system is actuated by a rear-end collision, where the angle and speed of the collision, and the nature of the colliding vehicle all have an influence.

WARNING

The WHIPS system is a supplement to the seatbelts. Always use a seatbelt.

Properties of the seat

When the WHIPS system is deployed, the front seat backrests are lowered backward to alter the seating position of the driver and front seat passenger. This reduces the risk of whiplash injury.

WARNING

Never modify or repair the seat or WHIPS system yourself. Contact an authorised Volvo workshop.

WHIPS system and child seats/ booster cushions

The WHIPS system does not diminish the protection provided by the car to children seated in a child seat or on a booster cushion.

Correct seating position

For the best possible protection, the driver and front seat passenger should sit in the centre of the seat with as little space as possible between the head and the head restraint.



Do not obstruct the WHIPS system



WARNING

Do not squeeze rigid objects between the rear seat cushion and the front seat backrest. Make sure you do not to obstruct the function of the WHIPS system.



WARNING

If a rear seat backrest is folded down, the corresponding front seat must be moved forward so that it does not touch the folded backrest.

WARNING

If a seat has been subjected to extreme forces, such as due to a rear-end collision, the WHIPS system must be checked by an authorised Volvo workshop.

Part of the WHIPS system's protective capacity may have been lost even if the seat appears to be undamaged.

Contact an authorised Volvo workshop to have the system checked even after a minor rear-end collision.



When the systems deploy

| System | Triggered |
|---------------------------|--|
| Seatbelt tensioner | In a frontal collision and/or side-impact accident and/or overturning. |
| Airbags (SRS) | In a frontal collision ¹ . |
| Side airbags (SIPS) | In a side-impact accident ¹ . |
| Inflatable Curtain IC | In a side-impact accident ¹ . |
| Whiplash protection WHIPS | In a rear-end collision. |

¹The bodywork of the car could be greatly deformed in a collision even without airbag deployment. A number of factors such as the rigidity and weight of the object hit, the speed of the car, the angle of the collision etc. affects how the different safety systems of the car are triggered.

If the airbags have been deployed, the following is recommended:

- Have the car transported to an authorised Volvo workshop. Do not drive with deployed airbags.
- Let an authorised Volvo workshop replace components in the car's safety system.
- Always contact a doctor.

NOTE

The SRS, SIPS, IC and belt tensioner systems are deployed only once during a collision

WARNING

The airbag system's control module is located in the centre console. If the centre console is drenched with water or other liquid, disconnect the battery cables. Do not attempt to start the car since the airbags may deploy. Have the car transported to an authorised Volvo workshop.

WARNING

Never drive with deployed airbags. They can make steering difficult. Other safety systems may also be damaged. The smoke and dust created when the airbags are deployed can cause skin and eye irritation/injury after intensive exposure. In case of irritation, wash with cold water. The rapid deployment sequence and airbag fabric may cause friction and skin burns.



Crash mode

Driving after a collision



If the car is involved in a collision, the text **CRASH MODE - SEE MANUAL** may appear on the information display. This means that the car has reduced functionality. Crash mode is a protective state that is enforced when the collision may have damaged any of the car's vital functions, such as the fuel lines, sensors for one of the safety systems, or the brake system.

Attempting to start the car

First, check that no fuel is leaking from the car. There must be no smell of fuel either.

If everything seems normal and you have checked for indications of fuel leakage, you may attempt to start the car.

Firstly, remove the ignition key and then reinsert it. The car's electronics will then try to reset themselves to normal mode. Then try to start the car. If **CRASH MODE** is still shown on the display then the car must not be driven or towed. Even if the car appears to be driveable, hidden damage may make the car impossible to control once moving.

Moving the car

If **NORMAL MODE** is shown after **crash mode** has been reset, the car can be moved carefully out of a dangerous position. Do not move the car further than necessary.

WARNING

Never attempt to repair your car or reset the electronics yourself if the car has been in crash mode. This could result in personal injury or the car not functioning as normal. Always allow an authorised Volvo workshop to check and restore the car to **normal mode** after **CRASH MODE** has been displayed.

WARNING

Never, under any circumstances, attempt to restart the car if it smells of fuel when the **crash mode** message is displayed. Leave the car at once.

WARNING

If the car is in **crash mode** it must not be towed. It must be transported to an authorised Volvo workshop.



Child safety

Children should sit comfortably and safely

The position of a child in the car and the choice of equipment is dictated by the child's weight and size. For more information, see page 30.

i NOTE

Regulations regarding the placement of children in cars vary from country to country. Check what does apply.

Children of all ages and sizes must always sit correctly secured in the car. Never allow a child to sit on the knee of a passenger.

Volvo's own child safety equipment is designed for your car. Use Volvo genuine equipment to best ensure that the mounting points and attachments are correctly positioned and are sufficiently strong.

You may place:

- a child seat or booster cushion on the front passenger seat, provided the passenger airbag is not activated¹.
- a rear-facing child seat in the rear seat that uses the back of the front seat as support.

¹For information on activated/deactivated airbag (SRS) see page 19.

Child seats and airbags

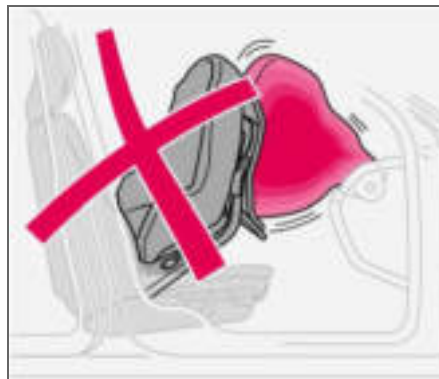

Child seats and airbags are not compatible.

Always place a child in the rear seat if the passenger airbag is activated¹. A child in a child seat on the front passenger seat may suffer serious injury if the airbag deploys.

! WARNING

Persons shorter than 140 cm may only sit in the front passenger seat if the passenger airbag is deactivated.

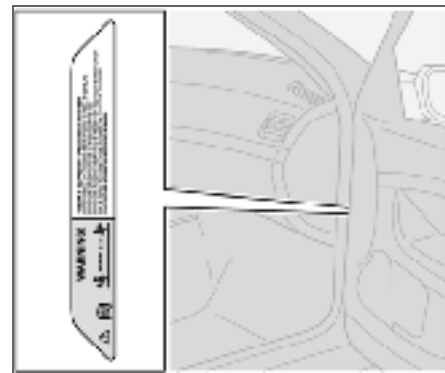

Location of airbag decal in door opening on front passenger side

! WARNING

Never place a child in a child seat or on a booster cushion in the front seat if the airbag (SRS) is activated¹. Failure to follow this advice can endanger the life of the child.

¹For information on activated/deactivated airbag (SRS), see page 19.



Decal located on instrument panel end face.



Decal located on instrument panel end face
(Australia only).



Child safety

Placement of children in the car

| Weight/age | Front seat ¹ | Rear seat |
|--------------------------|---|--|
| <10 kg (0–9 months) | Rear-facing child seat, secured with seatbelt and straps. Use a protective cushion between the child seat and the dashboard. L ² : Type approval no. E5 03135 | Rear-facing child seat, secured with seatbelt, support legs, straps and attachment eye ³ . L ² : Type approval no. E5 03135 |
| 9–18 kg (9–36 months) | Rear-facing child seat, secured with seatbelt and straps. Use a protective cushion between the child seat and the dashboard. L ² : Type approval no. E5 03135 | Rear-facing child seat, secured with seatbelt, support legs, straps and attachment eye. ³ L ² : Type approval no. E5 03135 |
| 15–36 kg (3–12 years) | Booster cushion with or without backrest. L ² : Type approval no. E5 03139 | Booster cushion with or without backrest. L ² : Type approval no. E5 03139 |

¹ For information on activating/deactivating the airbag (SRS), see page 19.

² L: Suitable for certain child seats as listed in the specified type approval. Child seats can be vehicle-specific, limited, semi-universal or universal.

³ To install a rear-facing child seat in the rear seat, contact an authorised Volvo dealer to have the mounting points installed.



Fitting a child seat

Volvo has child safety products that are designed for and tested by Volvo.

WARNING

Booster cushions/child seats with steel braces or some other design that could rest on the seatbelt buckle's opening button must not be used, as they could cause the seatbelt buckle to open accidentally. Do not allow the upper section of the child seat to rest against the windscreen.

When using other products that are available on the market, it is important to read the fitting instructions included with the product.

- Do not attach the straps for the child seat to the horizontal adjustment bar, springs, rails or beams under the seat. Sharp edges can damage the straps.
- Allow the back of the child seat to rest against the dashboard. This applies to cars without a passenger airbag, or where the airbag is deactivated.

WARNING

Never place the child seat in the front seat if the car is equipped with an activated¹ front passenger airbag. If problems arise when fitting child safety products, contact the manufacturer for clearer instructions.

¹For information on activated/deactivated airbag (SRS), see page 19.

ISOFIX fixture system for child seats (option)

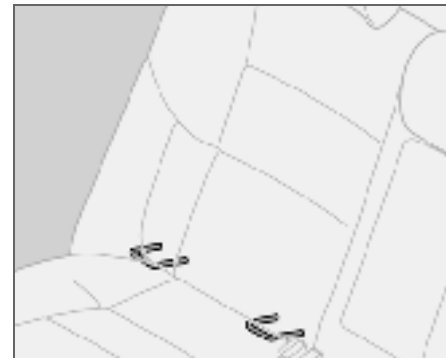

The outer rear seats have ISOFIX mounting points for child seats. Contact a Volvo dealer for further information on child safety equipment.

| | |
|--|----|
| Overview, left-hand drive car | 34 |
| Overview, right-hand drive car | 36 |
| Driver's door control panel | 38 |
| Combined instrument panel | 39 |
| Indicator and warning symbols | 40 |
| Information display | 43 |
| Electrical socket and switch, centre console | 45 |
| Lighting panel | 46 |
| Left-hand stalk switch | 48 |
| Right-hand stalk switch | 50 |
| Cruise control (option) | 52 |
| Steering wheel keypad (option) | 54 |
| Steering wheel adjustment, hazard warning flashers | 55 |
| Parking brake, electrical socket | 56 |
| Power windows | 57 |
| Rearview and door mirrors | 59 |
| Power sunroof (option) | 62 |
| Personal preferences | 64 |

INSTRUMENTS AND CONTROLS



02



02 Instruments and controls

Overview, left-hand drive car

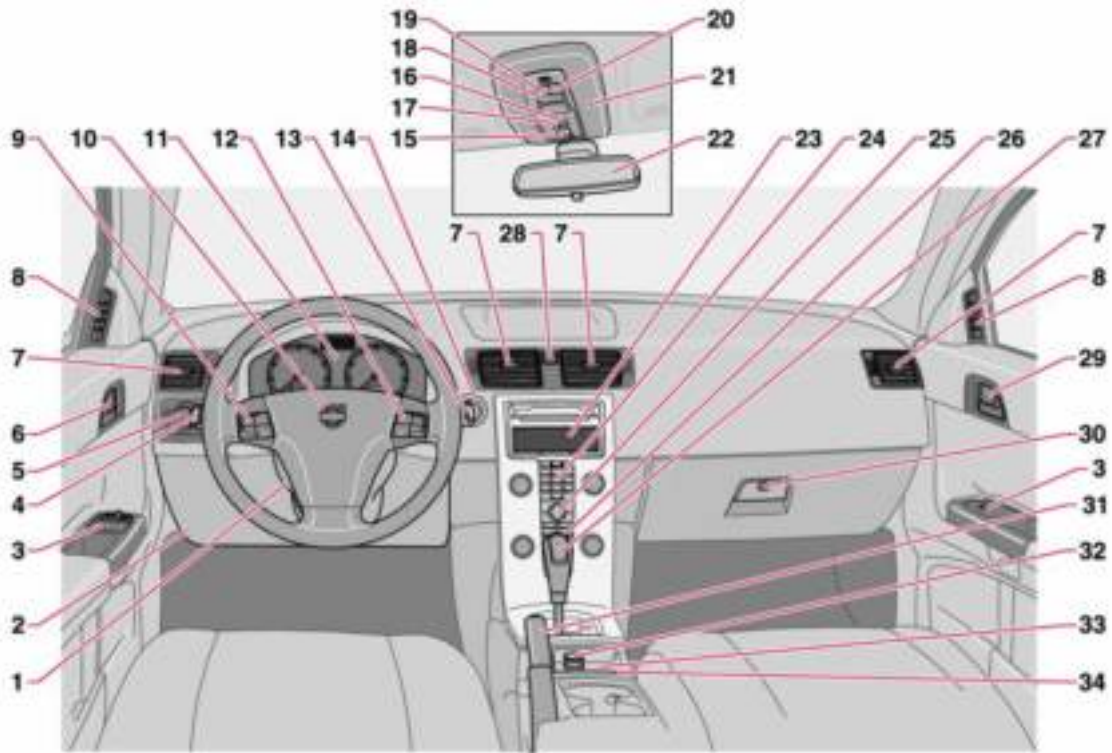

02



Overview, left-hand drive car

1. Steering wheel adjustment
2. Bonnet release
3. Control panel
4. Direction indicators, main beam, trip computer
5. Lighting, fuel filler flap opener
6. Door handle, lock button.
7. Air vents, dashboard
8. Air vent for side window
9. Cruise control
10. Horn, airbag
11. Combined instrument panel
12. Keypad for infotainment system
13. Windscreen wipers, washer and headlamp washers
14. Ignition switch
15. Sunroof controls
16. No function
17. Deactivation of alarm detectors, deadlocks
18. Interior lighting, switch
19. Reading lamp, left-hand side
20. Reading lamp, right-hand side
21. Seatbelt reminder
22. Interior rearview mirror
23. Display for climate control and infotainment system
24. Infotainment system
25. Controls for climate control, infotainment system and personal preferences
26. Climate control
27. Gear lever
28. Hazard warning flashers
29. Door handle
30. Glovebox
31. Parking brake
32. Electrical socket/cigarette lighter
33. Blind Spot Information System, BLIS
34. Switch, optional equipment



02 Instruments and controls

Overview, right-hand drive car

02

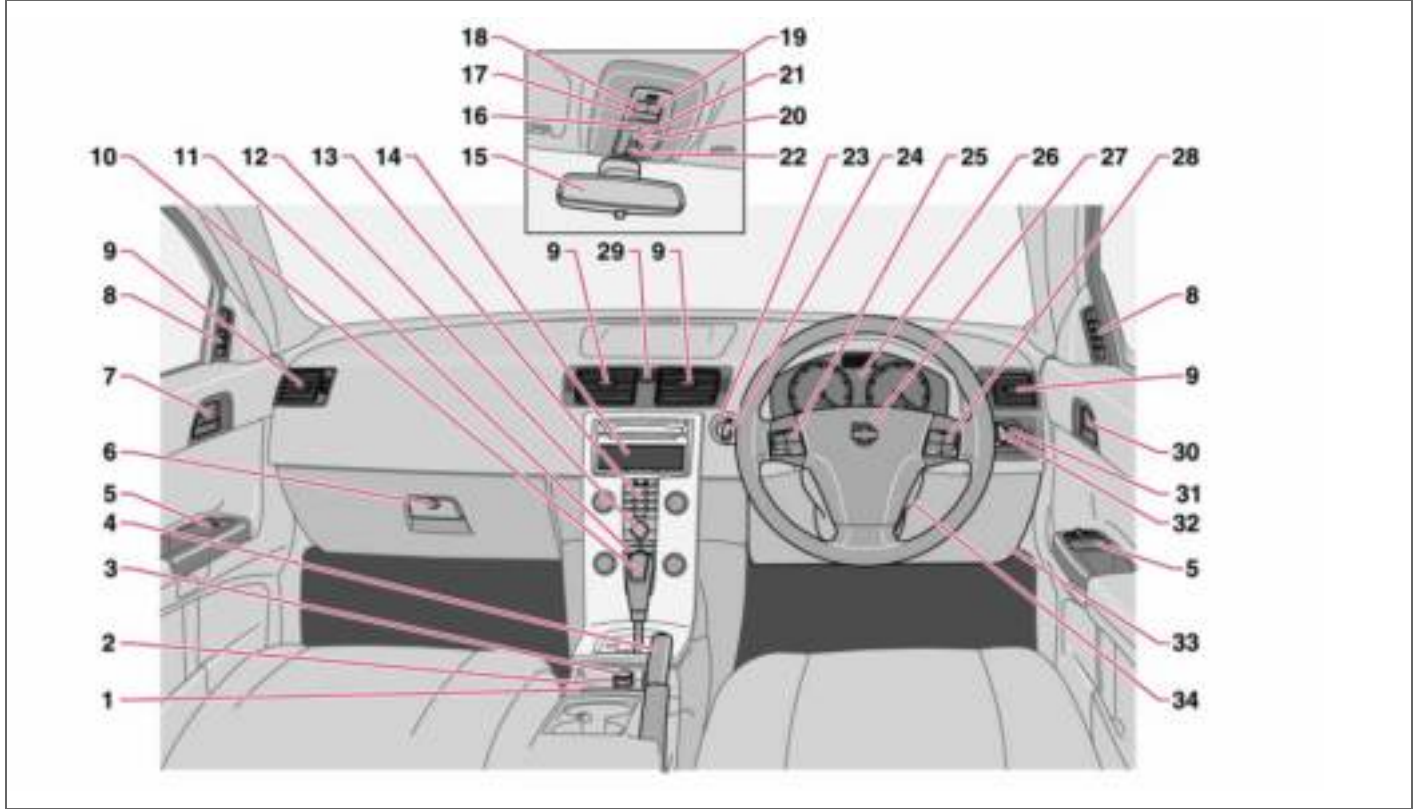

**Overview, right-hand drive car**

1. Switch, optional equipment
2. Blind Spot Information System, BLIS
3. Electrical socket, cigarette lighter
4. Parking brake
5. Control panel
6. Glovebox
7. Door handle
8. Air vent for side window
9. Air vents, dashboard
10. Gear lever
11. Climate control
12. Controls for climate control, infotainment system and personal preferences
13. Infotainment system
14. Display for climate control and infotainment system
15. Interior rearview mirror
16. Seatbelt reminder
17. Interior lighting, switch
18. Reading lamp, left-hand side
19. Reading lamp, right-hand side
20. No function
21. Deactivation of alarm detectors, deadlocks
22. Sunroof controls
23. Ignition switch
24. Windscreen wipers and washer, headlamp washers
25. Cruise control
26. Combined instrument panel
27. Horn, airbag
28. Keypad for infotainment system
29. Hazard warning flashers
30. Door handle, lock button
31. Lighting, fuel filler flap opener
32. Direction indicators, main beam, trip computer
33. Bonnet release
34. Steering wheel adjustment



Driver's door control panel

Driver's door control panel

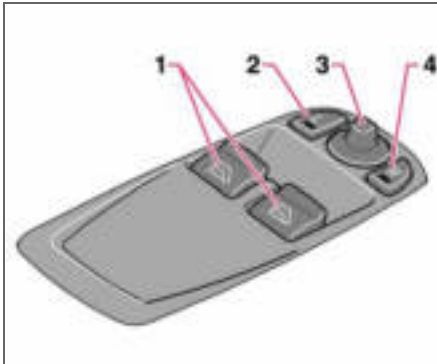

1. Power windows
2. Door mirror, left-hand side
3. Door mirrors, setting
4. Door mirror, right-hand side



Combined instrument panel

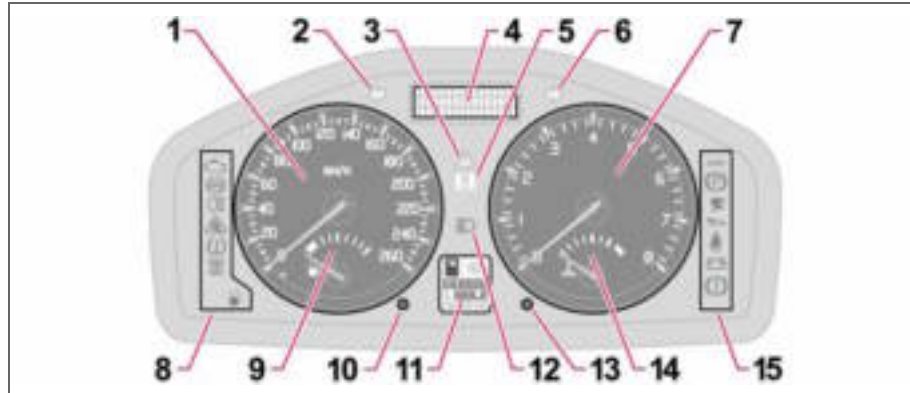

1. Speedometer.
2. Direction indicators, left.
3. Warning symbol.
4. Information display – The display presents information or warning messages, outside temperature and the time. When the outside temperature is between +2 ℃ and –5 ℃, a snowflake symbol appears on the display. This warns of icy roads. The outside temperature gauge may show a slightly high reading after the car has been stationary.
5. Information symbol.
6. Direction indicator, right.
7. Tachometer – Indicates engine speed in thousands of revolutions per minute (rpm).
8. Indicator and information symbols.
9. Fuel gauge.
10. Button for trip meter – Used to measure short distances. Short presses on the button switches between the two trip meters T1 and T2. A long press (more than 2 seconds) resets an active trip meter to zero.
11. Display – Display for automatic gear position, rain sensor, odometer, trip meter and cruise control.
12. Main beam indicator.
13. Knob for clock – Turn the knob to adjust the time.
14. Temperature gauge – Displays the temperature of the engine cooling system. A message will appear on the display if the temperature becomes too high and the gauge goes into the red zone. Bear in mind that extra lights placed in front of the air intake, for example, reduce the cooling capacity at high outside temperatures and high engine loads.
15. Indicator and warning symbols.

Indicator and warning symbols

Functionality check, symbols

All indicator and warning symbols¹ illuminate when the ignition key is turned to position II before starting. This is to check that the symbols are working. When the engine starts, all the symbols should go out except the hand-brake symbol, which only goes out when the brake is disengaged.



If the engine does not start within five seconds, all symbols extinguish except the symbols for a fault in the car's emissions system and for low oil pressure. Certain symbols may have no function, depending on the car's specifications.

Symbols in the centre of the instrument panel

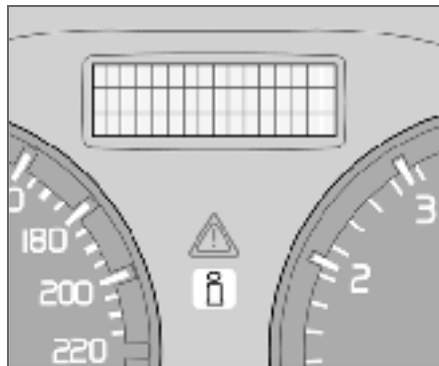

The red warning symbol illuminates when a fault has been indicated which could affect the safety and/or driveability of the car. An explanatory text is

shown on the information display at the same time. Symbol and message text are visible until the fault has been rectified.

The warning symbol can also illuminate in conjunction with other symbols.

- Stop in a safe place. Do not drive the car further.

- Read the information on the information display.
- Rectify the fault as instructed or contact an authorised Volvo workshop.



When one of the car's systems does not behave as intended, the yellow information symbol illuminates and a text appears on the information display. The

message text is cleared using the **READ** button, see page 43, or it disappears automatically after two minutes.

The yellow information symbol can also illuminate in conjunction with other symbols.

NOTE

When the message text **TIME FOR REGULAR SERVICE** is shown, the symbol lamp and message text are cleared using the **READ** button, or disappear automatically after two minutes.

¹ For certain engine variants, the symbol for low oil pressure is not used. Warnings are made via display text, see page 174.



Indicator and warning symbols

Indicator symbols – left-hand side

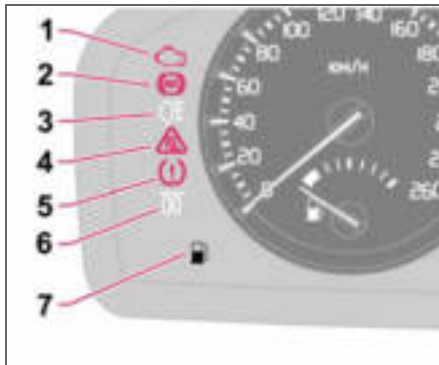

1. Fault in car's emissions system



Drive to an authorised Volvo workshop to have the system checked.

2. ABS fault



If this symbol illuminates then the system is not working. The car's regular brake system continues to work, but without the ABS function.

- Stop the car in a safe place and turn off the engine.
- Restart the engine.

- Drive to an authorised Volvo workshop to have the ABS checked if the symbol remains lit.

3. Rear fog lamp

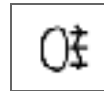

This symbol is lit when the rear fog lamp is on.

4. Stability system STC or DSTC



For information on the system's functions and symbols, see page 121.

5. No function

6. Engine preheater (diesel)

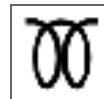

This symbol illuminates during engine preheating. Preheating occurs when the temperature is below $-2\text{ }^{\circ}\text{C}$. The car can be started once the symbol

goes out.

7. Low level in fuel tank



This symbol illuminates when there are approximately 8 litres of usable fuel left in a petrol-engined car, or approximately 7 litres in a diesel-engined car.

Indicator symbols – right-hand side

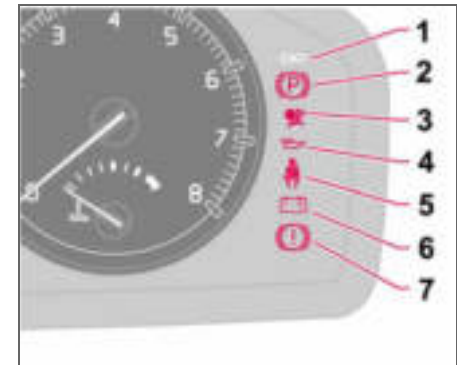

1. Indicator symbol for trailer

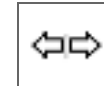

This symbol flashes when the direction indicators are used and the trailer is connected. If the symbol does not flash then one of the lamps on the trailer or the car is faulty.

Indicator and warning symbols

2. Parking brake applied



The lamp illuminates when the parking brake is applied. Always pull the parking brake lever to the end position.

NOTE

The lamp illuminates irrespective of how hard the parking brake is applied.

3. Airbags – SRS



If this symbol remains on or illuminates while driving, it means a fault has been detected in the seatbelt buckle, SRS, SIPS, or IC systems. Drive immediately to an authorised Volvo workshop to have the system checked.

4. Low oil pressure¹

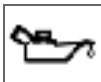

If this symbol illuminates during driving then the engine's oil pressure is too low. Stop the engine immediately and check the engine oil level, top up if necessary. If the symbol lights up and the oil level is normal, contact an authorised Volvo workshop.

¹ For certain engine variants, the symbol for low oil pressure is not used. Warnings are made via display text, see page 174.

5. Seatbelt reminder



This symbol lights if someone in a front seat has not put on their seatbelt or if someone in a rear seat has taken off their seatbelt.

6. Alternator not charging

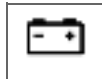

If this symbol illuminates while driving, a fault has occurred in the electrical system. Contact an authorised Volvo workshop.

7. Fault in brake system



If this symbol lights, the brake fluid level may be too low.

- Stop the car in a safe place and check the level in the brake fluid reservoir, see page 177. If the level in the reservoir is below MIN, the car should not be driven any further. Have the car transported to an authorised Volvo workshop to have the brake system checked.

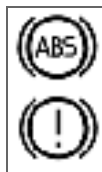

If the BRAKE and ABS symbols illuminate at the same time, there may be a fault in the brake force distribution system.

- Stop the car in a safe place and turn off the engine.
- Restart the engine.
- If both symbols extinguish, continue driving.
- If the symbols remain on, check the level in the brake fluid reservoir. See page 177.
- If the brake fluid level is normal but the symbols are still lit, the car can be driven, with great care, to an authorised Volvo workshop to have the brake system checked.
- If the level in the reservoir is below **MIN**, the car should not be driven any further. Have the car transported to an authorised Volvo workshop to have the brake system checked.

WARNING

If the BRAKE and ABS symbols are illuminated at the same time, there is a risk that the rear end will skid during heavy braking.



Information display

Reminder – doors not closed

If one of the doors, the bonnet¹ or the tailgate is not properly closed, the driver will be reminded of this.

Low speed



If the car is travelling at a speed lower than approx. 7 km/h, the information symbol will illuminate and one of the following texts will be shown on the display:

DRIVER DOOR OPEN, PASSENGER DOOR OPEN, or ENGINE HOOD OPEN. Stop the car as soon as it is safe to do so and close the open door or bonnet.

High speed



If the car is moving faster than approx. 7 km/h, the symbol illuminates and one of the texts indicated in the previous paragraph appears in the display.

Tailgate reminder



If the tailgate is open, this information symbol will illuminate and **TAILGATE OPEN** will appear on the display.

Messages

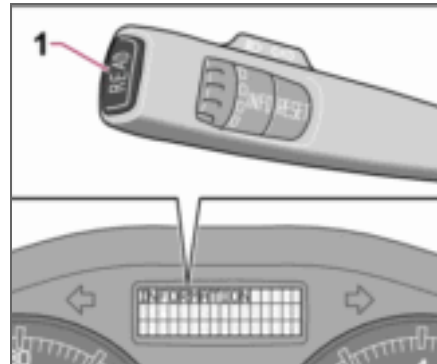

When a warning or indicator symbol illuminates, a message appears on the information display.

- Press the **READ** button (1).

Switch between messages with the **READ** button. Error messages are stored in a memory list until the fault is rectified.

NOTE

If a warning message appears while you are using the trip computer, the message must be read (press **READ**) before the previous activity can be resumed.

¹ Only cars with alarm.



02 Instruments and controls

Information display

| Message | Specification |
|------------------------------------|---|
| STOP SAFELY | Stop the car in a safe manner and turn off the engine. Serious risk of damage. |
| STOP ENGINE | Stop the car in a safe manner and turn off the engine. Serious risk of damage. |
| SERVICE URGENT | Have the car checked by an authorised Volvo workshop immediately. |
| SEE MANUAL | Read the owner's manual. |
| SERVICE REQUIRED | Have the car checked by an authorised Volvo workshop as soon as possible. |
| TIME FOR REGULAR SERVICE | Time for regular service at an authorised Volvo workshop. The timing is determined by the number of kilometres driven, number of months since the last service and engine running time. |
| CHECK OIL LEVEL | Check the oil level. The message is shown every 10 000 km ¹ . For information on checking the oil level, see page 175. |
| SOOT FILTER FULL SEE MANUAL | Diesel particle filter requires regeneration, see page 111. |
| STC/DSTC SPIN CONTROL OFF | The function of the stability and traction control system is reduced, see page 122 for more variants. |

¹Certain engine variants

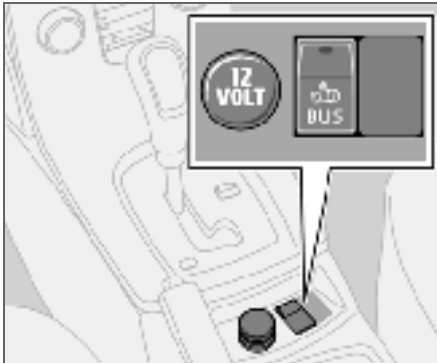
**Electrical socket and switch, centre console****12 V electrical socket**

Electrical socket, BLIS and extra equipment

The electrical socket can be used for 12 V accessories, such as mobile phone chargers and coolers. The maximum current is 10 A. For the socket to supply current, the ignition key must be in at least position I.

⚠ WARNING

Always leave the plug in the socket when the socket is not in use.

Cigarette lighter (option)

Activate the lighter by pushing in the button. The button pops out when the lighter is hot. Pull out the lighter and light a cigarette on the heated coils.

Extra equipment

Space for an extra switch for retrofitted equipment.

02

Lighting panel

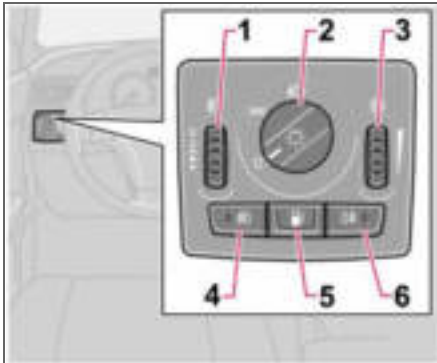

| Position | Specification |
|----------|---|
| 0 | Automatic/deactivated dipped beam. Only main beam flash. |
| | Position/parking lamps |
| | Automatic dipped beam. Main beam and main beam flash work in this position. |

Headlamp levelling

The load in the car changes the vertical alignment of the headlamp beam, which could dazzle oncoming motorists. Avoid this by adjusting the height of the beam.

- Turn the ignition key to position **II**.
- Turn the headlamp control (2) to one of the end positions.
- Roll the control (1) up or down respectively to raise or lower beam alignment.

Cars with Bi-Xenon headlamps¹ have automatic headlamp levelling, so there is no control (1).

Position/parking lamps

Position/parking lamps can be switched on irrespective of ignition key position.

- Turn the headlamp control (2) to the centre position.

When the ignition key is in position **II** the position/parking lamps and number plate lighting are always on.

Headlamps

Automatic dipped beam (certain countries)

Dipped beam comes on automatically when the ignition key is turned to position **II**, ex-

¹Option.

cept when the headlamp control (2) is in the centre position. If necessary, the automatic dipped beam can be deactivated by an authorised Volvo workshop.

Automatic dipped beam, main beam

- Turn the ignition key to position **II**.
- Dipped beam is activated by means of turning the headlamp control (2) clockwise to the end position.
- Main beam is activated by means of moving the left-hand stalk switch towards the steering wheel to the end position and releasing it, see page 48.

The lamps are switched off automatically when the ignition key is turned to position **I** or **0**.

Instrument lighting

The instrument lighting is switched on when the ignition key is in position **II** and the headlamp control (2) is in one of the end positions. The lighting is automatically dimmed during the day and can be controlled manually at night.

- Roll the control up or down (3) for brighter or dimmer lighting.

02

**Lighting panel****Enhanced display lighting**

To facilitate reading the odometer, trip meter, clock and outside temperature gauge, these illuminate when the car is unlocked and when the key is removed from the ignition switch. The displays extinguish when the car is locked.

Fog lamps** NOTE**

Regulations for use of fog lamps vary from country to country.

Front fog lamps (option)

The front fog lamps can be switched on along with the headlamps or the position lamps/parking lamps.

- Press the button (4).

The light in the button (4) illuminates when the front fog lamps are switched on.

Rear fog lamp

The rear fog lamp can only be switched on with the headlamps or the front fog lamps.

- Press the button (6).

The rear fog lamp indicator symbol on the combined instrument panel and the light in

the button (6) illuminate when the rear fog lamp is switched on.

Fuel filler flap

Press button (5) to open the fuel filler flap when the car is unlocked, see page 110.

Left-hand stalk switch

Stalk switch positions

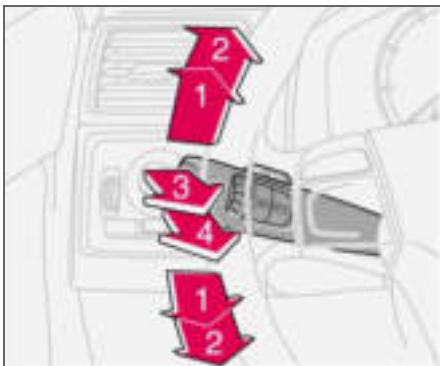

1. Short flash sequence, direction indicators
2. Continuous flash sequence, direction indicators
3. Main beam flash
4. Switching, main and dipped beam, and home safe lighting

Direction indicators

Continuous flash sequence

- Move the stalk switch up or down to end position (2).

The stalk switch remains in its end position and is moved back manually, or automatically by steering wheel movement.

Short flash sequence

- Move the stalk switch up or down to position (1) and release.

The direction indicators flash three times and the stalk switch returns to its home position.

Switching, main and dipped beam

The ignition key must be in position II for main beam to be switched on.

- Turn the headlamp control clockwise to the end position, see page 46.
- Move the stalk switch towards the steering wheel to the end position (4) and release.

Main beam flash

- Move the stalk switch gently towards the steering wheel to position (3).

Main beam comes on until the stalk switch is released.

Home safe lighting

Some of the exterior lighting can be kept switched on to work as home safe lighting after the car has been locked. The standard delay is 30 seconds¹, but can be changed to 60 or 90 seconds, see page 65.

- Remove the key from the ignition switch.

- Move the stalk switch towards the steering wheel to the end position (4) and release.
- Get out of the car and lock the door.

¹ Factory settings.



Left-hand stalk switch

Trip computer (option)

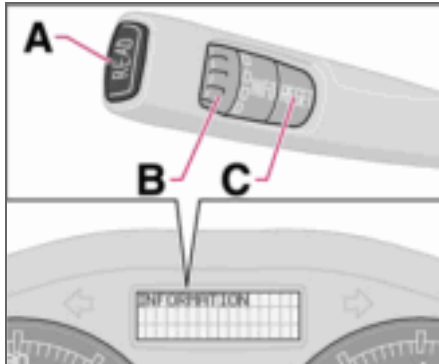

Controls

To scroll through trip computer information turn the thumbwheel (B) either up or down in steps. Continue turning to return to the starting point.

i NOTE

If a warning message interrupts while you are using the trip computer, this message must be acknowledged. Acknowledge by pressing the **READ** button (A) and revert to the trip computer function.

Functions

The trip computer displays the following information:

- **AVERAGE SPEED**
- **ACTUAL SPEED MPH¹**
- **INSTANTANEOUS**
- **AVERAGE**
- **KILOMETRES TO EMPTY TANK**
- **STC/DSTC**, see page 121

AVERAGE SPEED

When the ignition is switched off, the average speed is stored and used as the basis of the new value when you continue driving. Reset using the **RESET** button (C).

ACTUAL SPEED¹

Current speed is displayed in mph.

INSTANTANEOUS

Current fuel consumption is calculated every second. The information on the display is updated every couple of seconds. When the car is stationary, "----" appears on the display. During the period for regeneration² fuel consumption may increase, see page 111.

¹ Certain countries.

² Only applies to diesel cars with particle filter.

AVERAGE

The average fuel consumption since the last reset (**RESET**). The average fuel consumption is stored when the ignition is switched off and remains until the function is reset. Reset using the **RESET** button (C).

i NOTE

There may be a slight error in the reading if a fuel-driven heater is used.

KILOMETRES TO EMPTY TANK

The range to empty is calculated based on the average fuel consumption over the last 30 km. When the range to empty is shorter than 20 km then "----" is shown on the display.

i NOTE

There may be a slight error in the reading if fuel consumption is changed due to a change in driving style or if a fuel-driven heater is used for example.

Resetting

- Select **AVERAGE SPEED** or **AVERAGE**
- Press and hold the **RESET** button (C) for at least five seconds to reset the average speed and average consumption at the same time.



Right-hand stalk switch

Windscreen wipers

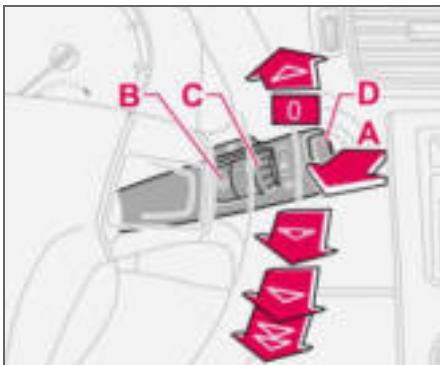

- A. Windscreen and headlamp washers
- B. Rain sensor – On/Off
- C. Thumbwheel
- D. Wiper and washer, rear window

Windscreen wipers off

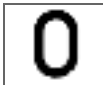

The windscreen wipers are off when the stalk switch is in position 0.

Single sweep

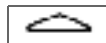

Raise the stalk switch to make a single sweep.

Intermittent wiping



The delay between sweeps can be adjusted. Turn the thumbwheel (C) up for a shorter interval between sweeps. Turn it down to increase the delay.

Continuous wiping



The wipers sweep at normal speed.
The wipers sweep at high speed.

IMPORTANT

Use plenty of washer fluid when the wipers are cleaning the windscreen. The windscreen must be wet when the windscreen wipers are operating.

Windscreen/headlamp washers

Move the stalk switch toward the steering wheel to start the windscreen and headlamp washers. The wipers will make three more sweeps once the stalk switch is released.

High-pressure headlamp washing (option in certain markets)

High-pressure headlamp washing consumes a large quantity of washer fluid. To save fluid, the headlamps are washed as follows:

Dipped beam selected with the switch on lighting panel:

The headlamps are washed the first time the windscreen is washed. Within the next ten minutes, they are washed every fifth wash cycle of the windscreen. In the event of a longer interval the headlamps are washed each time.

Parking/position lamps selected with the switch on the lighting panel:

- Bi-Xenon headlamps are only washed every fifth wash cycle irrespective of the time that elapses.
 - Halogen headlamps are not washed.
- The switch on the lighting panel is in position 0:
- Bi-Xenon headlamps are only washed every fifth wash cycle irrespective of the time that elapses.
 - Halogen headlamps are not washed.



Right-hand stalk switch

Wiper and washer, rear window

Press the stalk switch forward to initiate rear window washing and wiping. The wiper blade makes several sweeps once washing has finished. The control at the end of the stalk has three positions:

Intermittent wiping:

- Depress the top of the switch.

Normal speed:

- Depress the bottom of the switch.

Neutral:

- Function deactivated.

Wiper – reversing

Engaging reverse gear while the windscreen wipers are on initiates intermittent rear window wiping. If the rear window wiper is already on at normal speed, no change is made.

The function for intermittent wiping for reverse can be deactivated. Contact an authorised Volvo workshop.

Rain sensor (option)

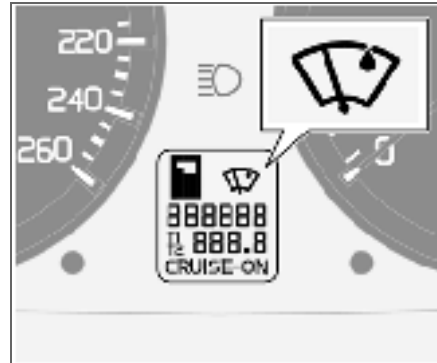

The rain sensor automatically activates the windscreen wipers based on how much water it detects on the windscreen. The sensitivity of the rain sensor can be adjusted using the thumbwheel (C).

Turn the thumbwheel clockwise for higher sensitivity and anticlockwise for lower sensitivity. (An extra sweep is made when the thumbwheel is turned clockwise.)

On/Off

When activating the rain sensor, the ignition key must be in position **I** or **II** and the windscreen wiper stalk switch must be in position **0**.

Activating the rain sensor:

- Press the button (B). A display symbol shows that the rain sensor is active.

To turn the rain sensor off, either:

- Press button (B)
- Press the stalk switch downward to another wiper program. If the stalk switch is raised, the rain sensor will remain active, the wipers make an extra sweep and then return to rain sensor mode when the stalk is released to position **0**.

The rain sensor is automatically deactivated when the key is removed from the ignition switch or five minutes after the ignition is switched off.



IMPORTANT

At an automatic car wash: Deactivate the rain sensor by pressing the button (B) while the ignition key is in position **I** or **II**. Otherwise, the windscreen wipers could start swiping and become damaged.

Thumbwheel

Use the thumbwheel to adjust the frequency of sweeps when intermittent wiping is selected, or the sensitivity to rain when the rain sensor is selected.



Cruise control (option)

Activating

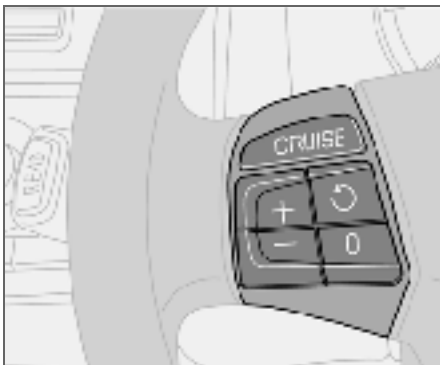

The controls for cruise control are to the left of the steering wheel.

Setting the desired speed:

- Press the **CRUISE** button. **CRUISE** is shown on the combined instrument panel.
- Touch **+** or **-** to lock the vehicle speed. **CRUISE-ON** appears on the combined instrument panel.

Cruise control cannot be engaged at speeds below 30 km/h or above 200 km/h.

Increasing or decreasing speed

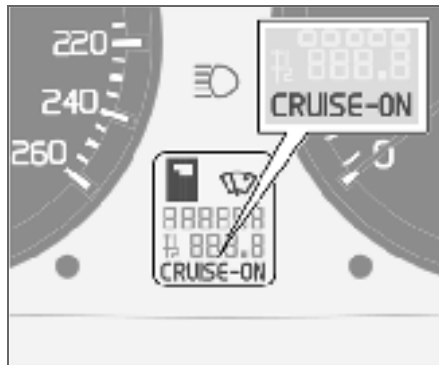

- Increase or decrease the locked speed by pressing and holding **+** or **-**. The speed of the car when the button is released is set as the new speed.

Pressing (less than half a second) **+** or **-** changes the speed 1 km/h or 1.6 km/h¹.

NOTE

A temporary increase in speed (less than one minute) using the accelerator, such as while overtaking, does not affect the cruise control setting. When you release the accelerator, the car will return to the programmed speed.

¹ Depending on engine type.

Temporary disengagement

- Press **0** to disengage the cruise control temporarily. **CRUISE** will be shown on the combined instrument panel. The speed set earlier is stored in the memory.

The cruise control is also temporarily disengaged when:

- the brake pedal or clutch pedal is depressed
- speed falls below 25–30 km/h when travelling uphill¹
- the gear selector is moved to position **N**
- wheel spin or wheel lock-up occurs
- a temporary increase in speed lasts longer than one minute.

**Cruise control (option)****Return to the set speed**

– Press this button to resume the previously set speed. **CRUISE-ON** appears on the combined instrument panel.

Disengaging

- Press **CRUISE** to disengage the cruise control. **CRUISE-ON** goes out on the combined instrument panel.



Steering wheel keypad (option)

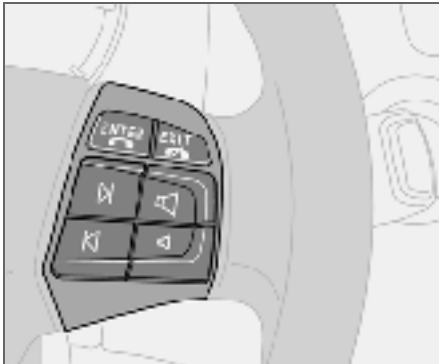

The four buttons at the bottom of the steering wheel keypad control the radio and the phone. The function of a button depends on which system is active. The steering wheel keypad can be used to scroll between preset stations, change CD tracks and adjust the volume.

Press and hold one of the arrow keys to fast forward/reverse or search for the next station.

The phone must be switched on to adjust audio system settings.

The phone must be activated with the **ENTER** key to enable control of the phone functions with the arrow keys.

To return to Audio only, press **EXIT**.



Steering wheel adjustment, hazard warning flashers

Steering wheel adjustment

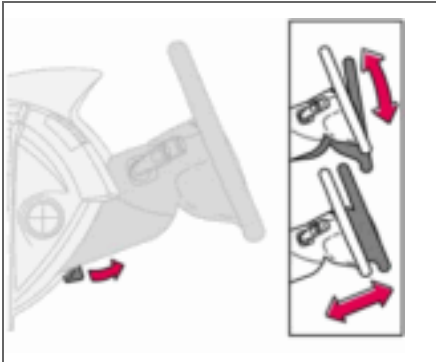

The steering wheel can be adjusted for both height and reach.

- Pull the lever towards you to release the steering wheel.
- Adjust the steering wheel to the position that suits you best.
- Push back the lever to fix the steering wheel in place. If the lever is stiff, press the steering wheel lightly at the same time as you push the lever back.

WARNING

Adjust the steering wheel before driving off, never while driving. Before driving, check that the steering wheel is fixed in position.

Hazard warning flashers



Use the hazard warning flashers (all direction indicators flash) when the car is stopped where it could be a traffic hazard or obstruction. Press the button to activate the function.

NOTE

Regulations regarding the use of hazard warning flashers vary from country to country.

Parking brake, electrical socket

Parking brake (handbrake)

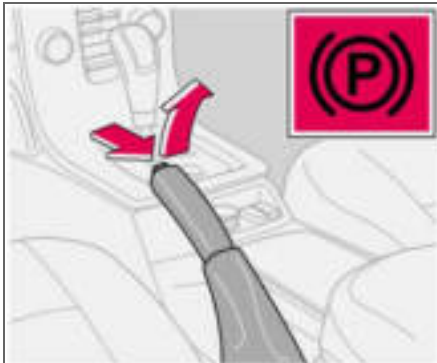

The lever is located between the front seats.

NOTE

The warning lamp symbol in the combined instrument panel comes on irrespective of how hard the parking brake is applied.

How to Apply the parking brake

- Press the foot brake pedal down firmly.
- Pull up the parking brake lever up firmly to its full extent.
- Release the foot brake pedal and make sure that the car is at a standstill position.

- If the vehicle rolls, the parking brake lever must be pulled more firmly.
- When parking a vehicle always put the gear selector in position **1** (for manual transmission) or **P** (for automatic transmission).

Parking on a hill

If the car is parked facing uphill; turn the wheels away from the kerb.

If the car is parked facing downhill; turn the wheels toward the kerb.

How to release the parking brake

- Press the foot brake pedal down firmly.
- Pull the parking brake lever up slightly, press the button, release the parking brake lever and release the button.

Electrical socket in rear seat

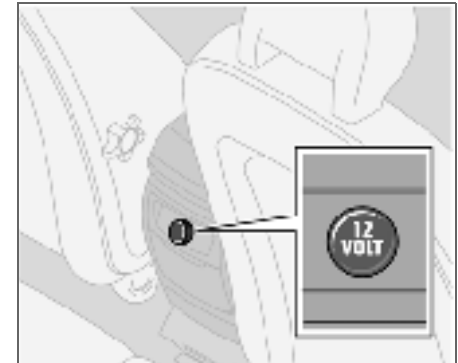

The electrical socket can be used for various accessories, such as a mobile phone or a cooler box. It is designed for 12 V. The maximum current is 10 A. The ignition key must be at least in position **I** so that the socket can supply power.

Cigarette lighter (option)

Press in the lighter to activate it. The lighter pops out again when it is ready. Pull it out and light a cigarette on the heated coils.



Power windows

Operating

The power windows are operated using the controls in the doors. The ignition key must be in position **I** or **II** for the power windows to operate. The windows continue to work for a limited time when the car is stopped and ignition key removed, provided none of the doors is opened. Operate the windows with caution.

To open a window:

- Depress the front of the control.

To close a window:

- Raise the front of the control.

Remote control and lock buttons

To operate the power windows with lock buttons and remote control, see page 94 and page 101.



WARNING

Make sure that children and other passengers cannot be trapped in any way when closing the windows. Pay close attention if the rear door windows are controlled from the driver's door or if the windows are closed with the remote control.

Driver's door

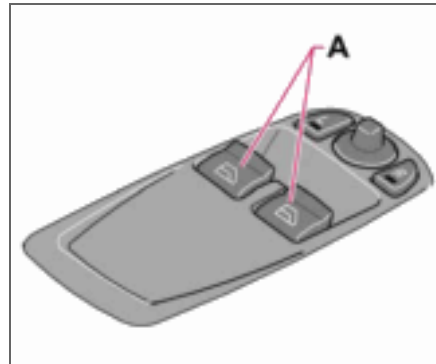

A. Controls, power windows front

The driver can operate both power windows from the driver's seat.

The windows can be opened and closed in two ways:

Manual operation

- Depress one of the controls (**A**) gently or raise it gently. The power window opens or closes as long as the switch is actuated.

Automatic operation

- Depress one of the controls (**A**) or raise it fully, then release. The side window will

then open or close automatically. If the window is obstructed by an object, the movement will stop.



WARNING

The function that interrupts the movement of the windows in the event of blocking works with both automatic and manual closing, although not with pinch protection deployed.



WARNING

If there are children in the car:

Remember to switch off the supply to the power windows by removing the ignition key if the driver leaves the car.

Make sure that children and other passengers cannot be trapped in any way when closing the windows.



Power windows

Passenger seat

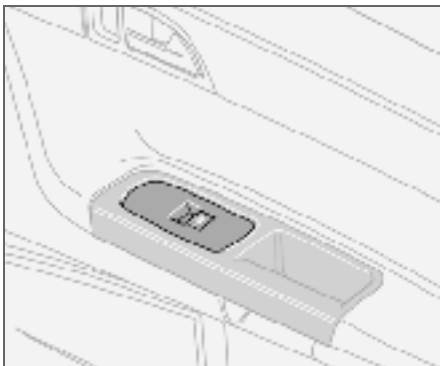

Passenger seat

The control in the front passenger door operates that window only.



Rearview and door mirrors

Interior rearview mirror

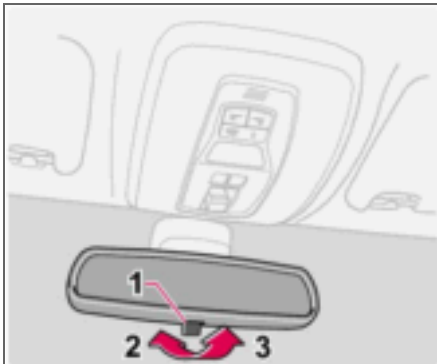

Bright light from behind could be reflected in the rearview mirror and dazzle the driver. Use dimming when disturbed by light from behind.

Dipping

1. Control for dimming
2. Normal position
3. Dimmed position.

Automatic dimming (option)

Bright light from behind is automatically dimmed by the rearview mirror. The control (1) is not available in mirrors with automatic dimming.

Interior rearview mirror with compass (option on certain markets)



The upper right-hand corner of the rearview mirror has an integrated display that shows the compass direction in which the front of the car is pointing. Eight different directions are shown with English abbreviations: **N** (north), **NE** (north east), **E** (east), **SE** (south east), **S** (south), **SW** (south west), **W** (west) and **NW** (north west).

Calibrating the compass

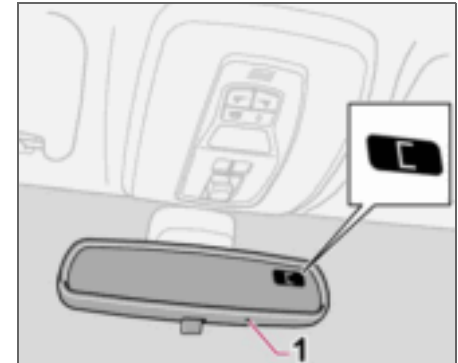

The earth is divided into 15 magnetic zones. The compass is set for the geographical area to which the car was delivered. The compass should be calibrated if the car is moved across several magnetic zones.

- Stop the car in a wide open area with the engine running at idling speed.
- Press and hold button (1) for at least 6 seconds. Following which, the character **C** is shown (the button is concealed so use a paper clip for example to press it in).
- Press and hold button (1) for at least 3 seconds. The number for the current magnetic zone is displayed.



02 Instruments and controls

Rearview and door mirrors

- Press the button (1) repeatedly until the number for the required magnetic zone (1–15) is shown, refer to the map of magnetic zones for the compass.
- Wait until the display returns to showing the character C.
- Following which, press and hold the button for 9 seconds and select L for left-hand drive cars and R for right-hand drive.

Drive slowly in a circle with a maximum speed of 10 km/h until a compass direction is shown on the display, which indicates that the calibration is complete.



Magnetic zones, Asia.



Magnetic zones, Australia.

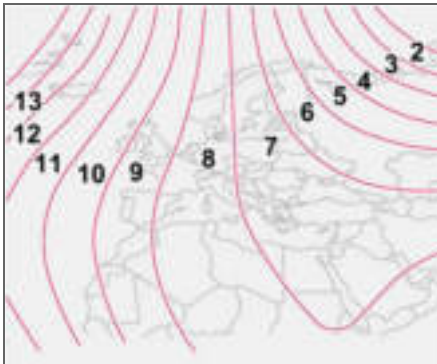

Magnetic zones, Europe.

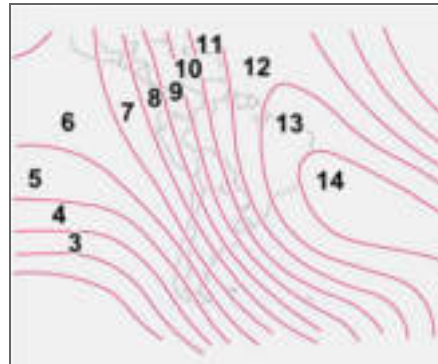

Magnetic zones, South America.

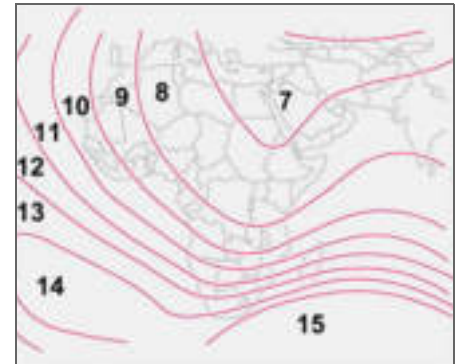

Magnetic zones, Africa.



Rearview and door mirrors

Door mirrors

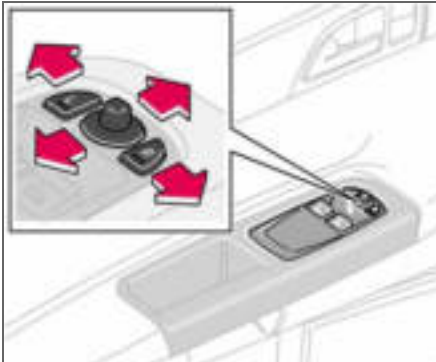

The controls for adjusting the two door mirrors are at the front of the driver's door armrest. The rearview mirrors can be operated in ignition position **I** and **II**.

- Press the **L** button for the left-hand door mirror or the **R** button for the right-hand door mirror. The light on the button illuminates.
- Adjust the position with the joystick in the centre.
- Press the **L** or **R** button again. The lamp goes out.

Retractable power door mirrors (option)

The mirrors can be retracted for parking and driving in narrow spaces. This can be done in ignition position **I** and **II**.

Retracting the mirrors

- Press down the **L** and **R** buttons at the same time.
- Release the buttons. The mirrors automatically stop in the fully retracted position.



IMPORTANT

Do not use a scraper to remove ice from the mirrors as this can scratch the glass. Use the defroster function instead, see page 71.



WARNING

The driver-side door mirror is wide angled to provide optimal vision. Objects may appear further away than they actually are.

Folding out the mirrors

- Press down the **L** and **R** buttons at the same time.
- Release the buttons. The mirrors automatically stop in the fully extended position.

Resetting to neutral

Mirrors that have been moved out of position by an external force must be reset to the neutral position for the electrical retracting and extending to work.

- Use the **L** and **R** buttons to retract the mirrors.
- Extend them again with the **L** and **R** buttons. The mirrors are now reset in neutral position.

Approach and home safe lighting

The lamp on the door mirrors (option) illuminates when the approach lighting or home safe lighting is activated.

Blind Spot Information System, BLIS (option)

BLIS is an information system that under certain conditions can help to draw the driver's attention to vehicles moving in the same direction in the so-called "blind spot", see page 125.

Power sunroof (option)

Open positions



The sunroof controls are located in the roof panel. The sunroof can be opened in two positions:

- A. Ventilation position, up at the rear edge
- B. Sliding position, backwards/forwards

The ignition key must be in position I or II.

WARNING

If there are children in the car:
Switch off the supply to the power sunroof by removing the ignition key if the driver leaves the car.

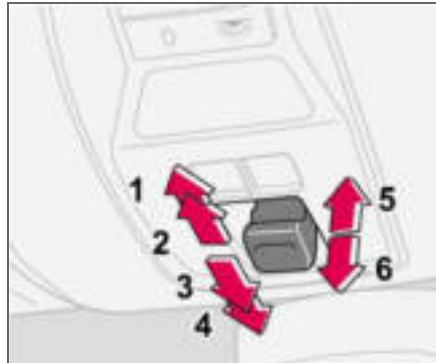

1. Opening, automatic
2. Opening, manual
3. Closing, manual
4. Closing, automatic
5. Opening, ventilation position
6. Closing, ventilation position

Ventilation position

To open:

- Pull the rear edge of the control (5) upward.

To close:

- Pull the rear edge of the control (6) downward.

From ventilation position to fully open sunroof:

- Pull the control rearward to the end position (1) and release.

Sliding position

Automatic operation

- Pull the control past the point of resistance (2) to the rear end position (1) or past the point of resistance (3) to the forward end position (4) and release. The sunroof opens/closes completely.

Manual operation

To open:

- Pull the control rearward to the point of resistance (2). The sunroof moves toward the fully open position as long as the button is held in this position.

To close:

- Press the control forward to the point of resistance (3). The sunroof moves toward the closed position as long as the button is held in this position.

WARNING

The sunroof's pinch-protection function only operates during automatic closing, not manual.



Power sunroof (option)

Closing with remote control or lock button

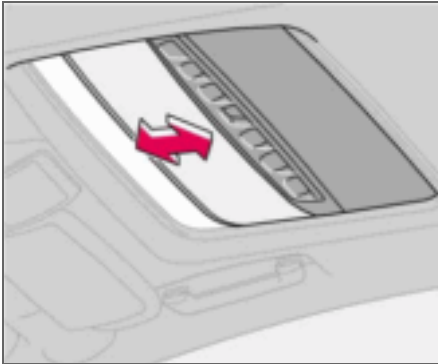

- Press and hold the lock button for two seconds. The sunroof and windows close. The doors lock.

If closing needs to be interrupted:

- Press the lock button again.

WARNING

Make sure that children or other passengers are not in danger of having hands trapped when closing the sunroof with the remote control. Always operate the sunroof with caution.

Sunscreen

The sunroof features a manual, sliding interior or sunscreen. The sunscreen slides back automatically when the sunroof is opened. Grip the handle and slide the screen forward to close it.

Pinch protection

The sunroof's pinch protection function is activated if the hatch is blocked by an object. If blocked, the sunroof will stop and automatically open to the previous position.

WARNING

The sunroof's pinch-protection function only operates during automatic closing, not manual.

Make sure children's hands are clear when closing the sunroof.



Personal preferences

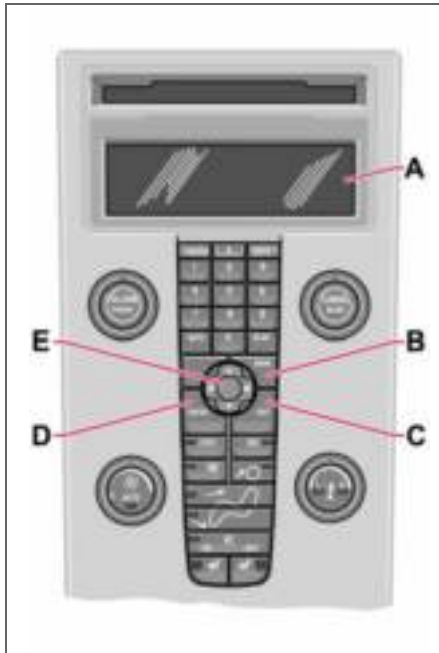

Control panel.

Possible settings

Personal preferences can be set for some of the car's functions. This applies to locks, climate control and audio functions. For audio functions, see page 196.

Control panel

- A. Display
- B. **MENU**
- C. **EXIT**
- D. **ENTER**
- E. Navigation

Use

The settings are shown on the display (A).

Open the menu to enter settings:

- Press **MENU** (B).
- Scroll, for example, to **Car Settings** with the navigation button (E).
- Press **ENTER** (D).
- Select an alternative with the navigation button (E).
- Press **ENTER** to activate the selection.

Close the menu:

- Press **EXIT** (C) for approximately one second.

Climate control settings

Auto blower adjust

The fan speed can be set to AUTO mode in cars equipped with ECC:

- Select from **Low**, **Normal** and **High**.

Recirculation timer

When the timer is active, the air recirculates for 3 – 12 minutes, depending on the outside air temperature.

- Select **On/Off** depending on whether or not you wish the recirculation timer to be active.

Reset all

Resets the climate function options to the factory settings.

Car settings

Unlock feedback light

The hazard warning flashers can provide feedback when the car is unlocked with the remote control. This function can be turned **On/Off**.

Lock feedback light

The hazard warning flashers can provide feedback when the car is locked with the remote control. This function can be turned **On/Off**.

02



Personal preferences

Automatic locking – doors

When the speed of the car exceeds 7 km/h the doors and tailgate can be locked automatically. This function can be turned **On/Off**.

Unlock doors

There are two alternatives for unlocking:

- **All doors** – one press of the remote control unlocks both doors and the tailgate.
- **Driver's door first, then all others** – one press of the remote control unlocks the driver's door. A second press then unlocks the passenger door and the tailgate.

Keyless entry

- **All doors** – both doors and the tailgate are unlocked at the same time.
- **One front door** – either of the front doors or the tailgate can be unlocked separately.

Approach lighting

Select the time the car's lights should remain on when the approach lighting button is pressed. The following alternatives are available: **30/60/90 seconds**.

Home safe lighting

Select the time the car's lights should remain on when the left-hand stalk switch is pulled back after the ignition key has been re-

moved. The following alternatives are available: **30/60/90 seconds**.

Information

- **VIN number** (Vehicle Identification Number). The car's unique identity number.
- **Number of keys**. The number of keys registered for the car is shown.

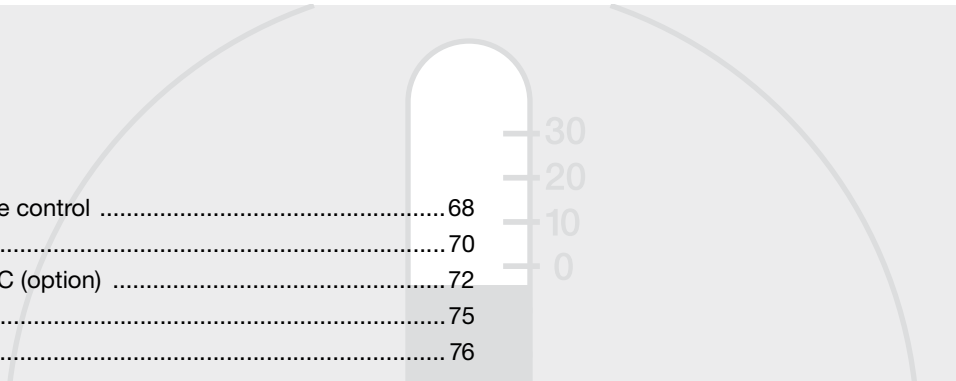

| | |
|--|----|
| General information on climate control | 68 |
| Manual climate control, A/C | 70 |
| Electronic climate control, ECC (option) | 72 |
| Air distribution | 75 |
| Fuel-driven heater (option) | 76 |

CLIMATE CONTROL



03





General information on climate control

Air conditioning

The climate control system cools or heats as well as dehumidifies the air in the passenger compartment. The car is equipped with either manual (A/C) or electronic climate control (ECC).

i NOTE

The air conditioning can be switched off, but to ensure the best possible air in the passenger compartment and prevent the windows from misting, it should always be on.

Misting windows

Reduce the problem of windows misting up on the inside by cleaning the windows. Use a regular window cleaner.

Ice and snow

Remove ice and snow from the climate control system air intake (the grille between the bonnet and the windscreen).

Fault tracing and repair

Entrust fault tracing and repair of the climate control system to an authorised Volvo workshop only.

Refrigerant

The air conditioning system contains R134a refrigerant. This refrigerant contains no chlorine, which means that it is harmless to the ozone layer. The system must only be charged with R134a refrigerant. Have an authorised Volvo workshop carry out this work.

Passenger compartment filter

All air entering the car's passenger compartment is only cleaned with one filter. This must be replaced at regular intervals. Follow the Volvo Service Programme for the recommended replacement intervals. If the car is used in a severely contaminated environment, it may be necessary to replace the filter more often.

i NOTE

There are different types of passenger compartment filter. Make sure that the correct filter is fitted.

Display

There is a display above the climate control panel. This displays climate control settings.

Personal preferences

You can set preferences for two climate control functions:

- Fan speed in **AUTO** mode (applies only to cars with ECC).
- Recirculation timer for passenger compartment air.

For information about these settings, see page 64.



General information on climate control

Air vents in the dashboard

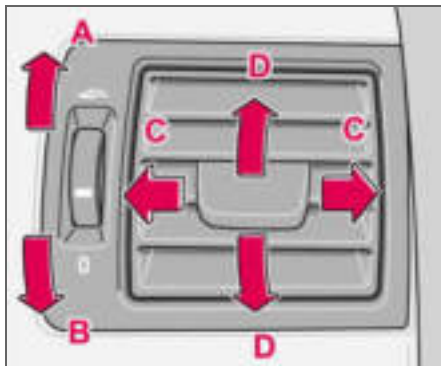

- A. Open
- B. Closed
- C. Lateral airflow
- D. Vertical airflow

Aim the outer vents towards the side windows to remove misting from the front side windows.

Cold weather: Close the centre vents for optimum comfort and best demisting.

ECC (option)

Actual temperature

The temperature you select corresponds to the physical experience with reference to factors such as air speed, humidity and solar radiation in and around the car.

Sensor location:

- The sun sensor is on the top side of the dashboard.
- The temperature sensor for the passenger compartment is behind the climate control panel.

NOTE

Do not cover or block the sensors with clothing or other objects.

Side windows and sunroof

To ensure that the air conditioning works satisfactorily, the side windows, and sunroof if appropriate, should be closed.

Acceleration

The air conditioning system switches off temporarily at full throttle. You may briefly feel a temporary rise in temperature.

Condensation

In warm weather, condensation from the air conditioning may drip under the car. This is normal.



Manual climate control, A/C

Control panel

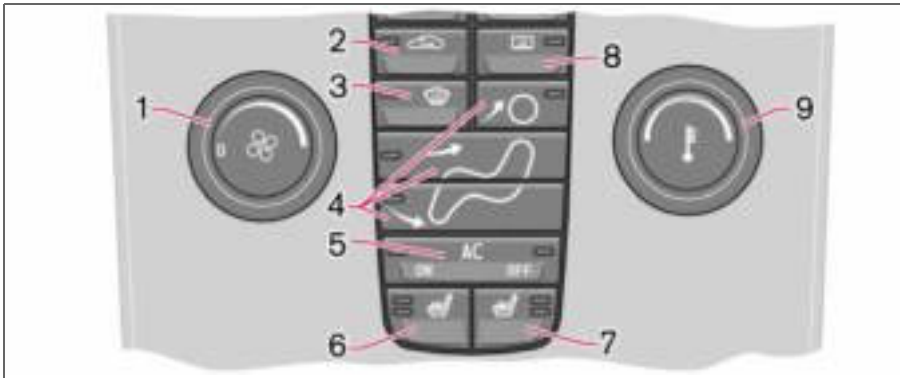

1. Fan
2. Recirculation
3. Defroster
4. Air distribution
5. A/C – On/Off (**ON/OFF**)
6. Heated front left seat
7. Heated front right seat
8. Rear window and door mirror defrosters
9. Temperature

Functions

1. Fan



Increase or decrease the fan speed by turning the knob.

If the knob is turned anti-clockwise and the fan indicator in the display goes out, the fan and the air conditioning are switched off. The display shows the fan symbol and **OFF**.

2. Recirculation



Recirculation can be used to shut out bad air, exhaust fumes, etc. from the passenger compartment. The air in the passenger compartment is recirculated. No outside air is taken into the

car. Recirculation (together with the air conditioning system) cools the passenger compartment more quickly in hot weather. If the air in the car recirculates for too long then there is a risk of the windows misting.



Manual climate control, A/C

Timer

The timer function reduces the risk of icing, misting and bad air (if recirculation is selected). See page 64, for how to activate/deactivate the function. When the Defroster (3) program is selected, recirculation is deactivated.

3. Defroster



Used to quickly remove misting and ice from the windscreen and side windows. Air flows to the windows at high fan speed. The light in the defroster button illuminates when the

function is active.

The following also takes place when the defroster function is activated in order to provide maximum dehumidification in the passenger compartment:

- the air conditioning (A/C) is automatically switched on (can be switched off with the A/C button (5))
- recirculation is automatically disengaged.

When the defroster function is switched off the climate control system returns to the previous settings.

4. Air distribution



The airflow can be distributed to the windows, dashboard vents or floor by pressing the air distribution buttons.

A symbol on the display above the climate control panel and an illuminated light in the button indicate which function has been selected.

Refer to the table on page 75.

5. A/C – On/Off



ON: Air conditioning is on. It is controlled by the system's AUTO function. This way, incoming air is cooled and dehumidified.

OFF: Air conditioning is off.

When the defroster function is activated the air conditioning is automatically switched on (can be switched off with the A/C button).

6. and 7. Heated front seats



(option in certain markets)

– Higher heat
Press the button once, both lights illuminate.

- Lower heat
Press the button twice, one light illuminates.
- Heat off
Press the button three times, light not illuminated.

8. Rear window and door mirror defrosters



Heating is used to quickly remove misting and ice from the rear window and door mirrors.

Press the switch once to start simultaneous rear window and rearview mirror defrosting. The function is active if one light is illuminated in the switch. The rearview mirror heating is deactivated automatically after approximately 6 minutes. The rear window heating is deactivated after approximately 12 minutes.

9. Temperature



Select cooling or heating for both driver and passenger side.

03



Electronic climate control, ECC (option)

Control panel

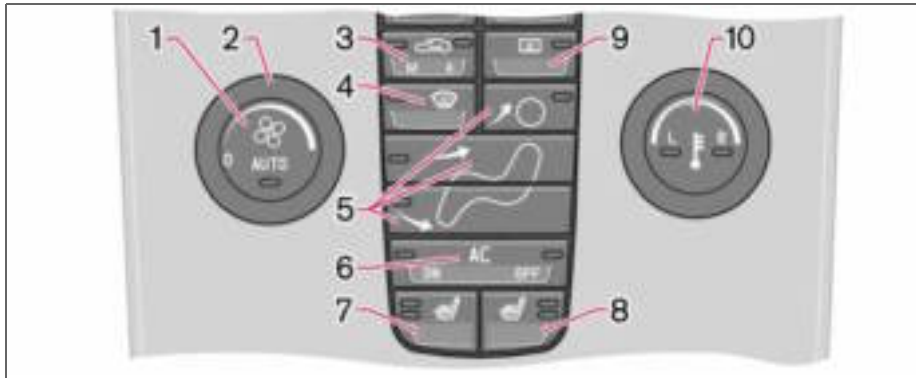

1. **AUTO**
2. Fan
3. Recirculation/Air quality system
4. Defroster
5. Air distribution
6. A/C – On/Off (**ON/OFF**)
7. Heated front left seat
8. Heated front right seat
9. Rear window and door mirror defrosters
10. Temperature selector

Functions

1. AUTO



The **AUTO** function automatically regulates climate control and maintains the selected temperature. The **AUTO** function controls heating, air conditioning, fan speed, recirculation, and air distribution. If you select one or more manual functions, the other functions continue to be controlled automatically. All manual settings

are switched off when **AUTO** is switched on. The display shows **AUTO CLIMATE**.

2. Fan



Turn the knob to increase or decrease fan speed. If **AUTO** is selected then fan speed is regulated automatically. The previously set fan speed is disengaged.



Electronic climate control, ECC (option)

NOTE

If the knob is turned anticlockwise and the fan indicator in the display goes out, the fan and the air conditioning are switched off. The display shows the fan symbol and **OFF**.

3. Recirculation



The function is selected to shut out bad air, exhaust gases etc. from the passenger compartment. The air in the passenger compartment is recirculated, i.e. no outside air is taken into the

car when this function is activated. If the air in the car recirculates for too long, there is a risk of misting on the insides of the windows.

Timer

The timer function reduces the risk of icing, misting and bad air (if recirculation is selected). See Personal preferences, page 64, for how to activate/deactivate the function.

NOTE

When Defroster (4) is selected, recirculation is always deactivated.

3. Air quality system (option)



(same button as recirculation)

The air quality system consists of a multi-filter and a sensor. The filter separates gases and particles to re-

duce the levels of odours and pollution in the passenger compartment. When the sensor detects polluted outside air, the air intakes are closed and the air in the passenger compartment is recirculated. A green light (**A**) illuminates in the button when the air quality sensor is active.

Activating the air quality sensor:

- Press **AUTO** (1) to activate the air quality sensor (normal setting).

Or:

- Switch between three functions by pressing the recirculation button repeatedly.
- Air quality sensor engaged – the light (**A**) illuminates.
- No recirculation engaged, provided it is not required for cooling in hot weather – light not illuminated.
- Recirculation engaged – the light (**M**) illuminates.

Keep the following in mind:

- As a rule, the air quality sensor should always be engaged.
- Recirculation is limited in cold weather to avoid misting.
- If the insides of the windows start misting up, disengage the air quality sensor.
- The defroster function for the front, side and rear windows can also be used to demist the windows.

4. Defroster



Used to quickly remove misting and ice from the windscreen and side windows. Air flows to the windows at high fan speed. The light in the defroster button illuminates when the

function is active.

The following also takes place when the defroster function is activated in order to provide maximum dehumidification in the passenger compartment:

- the air conditioning (A/C) is automatically switched on (can be switched off with the **A/C** button (6))
- recirculation is automatically disengaged.

When the defroster function is switched off the climate control system returns to the previous settings.



Electronic climate control, ECC (option)

5. Air distribution



The airflow can be distributed to the windows, dashboard vents or floor by pressing the air distribution buttons.

A symbol on the display above the climate control panel and an illuminated light in the button indicate which function has been selected.

Refer to the table on page 75.

6. A/C – On/Off (ON/OFF)



ON: Air conditioning is on. It is controlled by the system's AUTO function. This way, incoming air is cooled and dehumidified.

OFF: Air conditioning is off.

When the defroster function is activated the air conditioning is automatically switched on (can be switched off with the **A/C** button).

7. and 8. Heated front seats

(option in certain markets)



To activate front seat heating:

- Higher heat: Press the button once – both lights illuminate.
- Lower heat: Press the button twice – one light illuminates.
- Heat off: Press the button three times – light not illuminated.

9. Rear window and door mirror defrosters



Heating is used to quickly remove misting and ice from the rear window and door mirrors.

Press the switch once to start simultaneous rear window and rearview mirror defrosting. The function is active if one light is illuminated in the switch. The rearview mirror heating is deactivated automatically after approximately 6 minutes. The rear window heating is deactivated after approximately 12 minutes.

10. Temperature selector



The temperatures on the driver and passenger sides can be set independently.

Press the button once to activate one side only. Press again to activate the

other side. Press the button a third time to activate both sides.

The active side is indicated by the button's light and on the display above the climate control panel.









When the car is started, the most recent setting is resumed.

i NOTE

Heating or cooling cannot be hastened by selecting a higher or lower temperature than the actual desired temperature.



Air distribution

| Air distribution | Use: | | Air distribution | Use: | |
|---|--|---|---|---|--|
|  | <p>Air to windows. Some air flows from the air vents. The air is not recirculated. Air conditioning is always engaged.</p> | <p>To remove ice and misting quickly.</p> |  | <p>Air to the floor and windows. Some air flows from the dashboard air vents.</p> | <p>To ensure comfortable conditions and good demisting in cold or humid weather.</p> |
|  | <p>Air to windscreen and side windows. Some air flows from the air vents.</p> | <p>To prevent misting and icing in a cold and humid climate. (Not for low fan speed.)</p> |  | <p>Air to floor and from dashboard air vents.</p> | <p>In sunny weather with cool outside temperatures.</p> |
|  | <p>Airflow to windows and from dashboard air vents.</p> | <p>To ensure good comfort in warm, dry weather.</p> |  | <p>Air to floor. Some air flows to the dashboard air vents and windows.</p> | <p>To warm the feet.</p> |
|  | <p>Airflow to the head and chest from the dashboard air vents.</p> | <p>To ensure efficient cooling in warm weather.</p> |  | <p>Airflow to windows, from dashboard air vents and to the floor.</p> | <p>To cool the feet or provide warmer air to the upper body in cold weather or hot, dry weather.</p> |

03

Fuel-driven heater (option)

General information about heaters

The parking heater can be started immediately or set with two different start times using **TIMER 1** and **TIMER 2**. Here, start time refers to the time the car is heated and ready. The car's electronic system calculates when heating should be started based on the outside temperature. The heater is not run if the outdoor temperature exceeds 25 °C. At temperatures of -10 °C and below, the maximum running time of the parking heater is 60 minutes.

Parking on a hill

If the car is parked on a steep hill, the front of the car should point downhill to ensure that there is a supply of fuel to the parking heater.

WARNING

The car must be outdoors when the petrol or diesel heater is used.

WARNING

Switch off the fuel-driven heater before starting to refuel. Fuel which spills onto the ground can be ignited.

Check the information display to see that the heater is switched off. When the parking heater is running, **PARK HEAT ON** is shown on the information display.



Warning decal on fuel filler flap.

Activating the heater

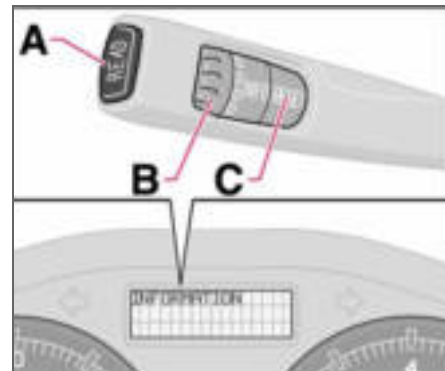

- Enter the time when the car is to be used. Press **RESET (C)** to enter the hours and minutes.
- Press and hold the **RESET (C)** button until the timer is activated.

Direct start

- Use the thumbwheel (B) to scroll to **DIRECT START**.
- Press **RESET (C)** to access the options **ON** and **OFF**.
- Select **ON**. The heater will now run for 60 minutes. Heating of the passenger compartment will begin as soon as the engine coolant has reached a temperature of 30 °C.

**Fuel-driven heater (option)****Immediate stop of heater**

- Use the thumbwheel (B) to scroll to **DIRECT START**.
- Press **RESET** (C) to access the options **ON** and **OFF**.
- Select **OFF**.

NOTE

The car can be started and driven while the parking heater is still running.

Battery and fuel

If the battery has insufficient charge or the fuel level is too low, the parking heater will be switched off automatically. A message appears on the information display. Acknowledge the message by pressing **READ** (A).

IMPORTANT

Repeated use of the parking heater combined with short journeys may discharge the battery and impair starting. If the heater is used regularly, the car must be driven for the same time as the heater is run to ensure that the alternator has time to charge the battery.

Setting the TIMER 1 and 2

For safety reasons, you can only programme times for the following 24 hours, not several days in advance.

- Scroll with the thumbwheel to **TIMER**.
- Touch **RESET** to move to the flashing hours setting.
- Scroll with the thumbwheel to the desired hour.
- Touch **RESET** to move to the flashing minutes setting.
- Scroll with the thumbwheel to the desired minute.
- Touch **RESET** to confirm the setting.
- Press **RESET** to activate the timer. After setting **TIMER 1** a second start time can be programmed with **TIMER 2**. Access this with the thumbwheel. Set the alternative start time in the same way as **TIMER 1**.

Messages on the display

When **TIMER 1**, **TIMER 2** and **DIRECT START** are activated, the information symbol on the combined instrument panel illuminates and an explanatory text appears on the information display. The display also indicates which **TIMER** is active when the driver removes the key from the ignition to leave the car.

Clock/timer

If the car clock is reset after the heater timers are programmed, the selected times will be cancelled.

Additional heater (diesel)

(certain countries)

Extra heat from the additional heater may be required in cold weather to reach the correct temperature in the passenger compartment.

The additional heater starts automatically when extra heat is required if the engine is running. It is switched off automatically when the correct temperature is reached or when the engine is switched off.

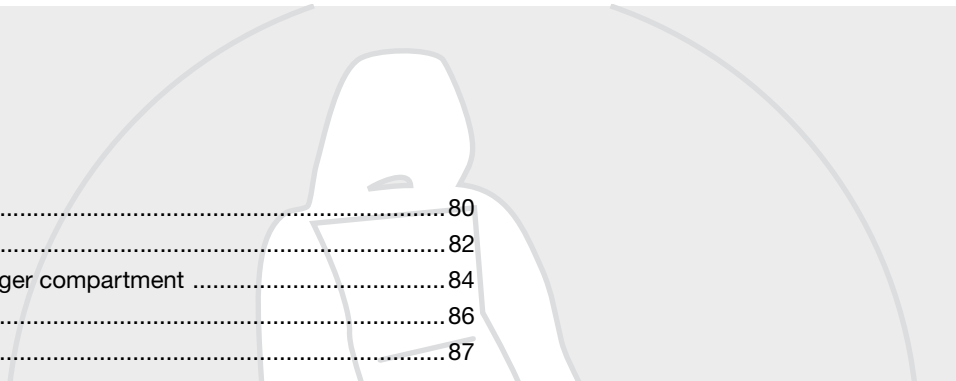

| | |
|---|----|
| Front seats | 80 |
| Interior lighting | 82 |
| Storage spaces in the passenger compartment | 84 |
| Rear seat | 86 |
| Cargo area | 87 |

INTERIOR



04





Front seats

Seating position



The driver's and passenger seats can be adjusted to the optimum sitting and driving positions.

1. Forward/backward: lift the handle to adjust the distance to the steering wheel and pedals. Check that the seat is locked after changing position.
2. Raise/lower front edge of seat cushion, pump up/down.
3. Raise/lower the seat, pump up/down.
4. Lumbar support¹, turn the wheel.
5. Adjust backrest rake, turn the wheel.
6. Control panel for power seat (option).

¹Also applies to power seat.

The lever (2) is not available for all seat models.

WARNING

Adjust the position of the driver's seat before setting off, never while driving.
Check that the seat is locked in position.

Entry to the rear seat – Easy entry

Make sure that the seatbelt is removed from the belt guide before passengers enter or exit the car, see page 14. The easy entry position is intended for use when the seat is empty.

Mechanical seat

Move the seat forward:

- Move the handle (1) up to release the backrest.
- Fold the backrest forward until it locks.
- Release the handle and slide the seat forwards.

Move the seat backward:

- Move the seat backward to the original position.
- Move the handle (1) up to fold the backrest back.

The seat returns to the same position it had before folding forward for easy entry.

Power seat

Move the seat forward:

- Move the handle (1) up to release the backrest.
- Fold the backrest forward until it locks.
- Press the button (2) located beside the head restraint. Keep it depressed.

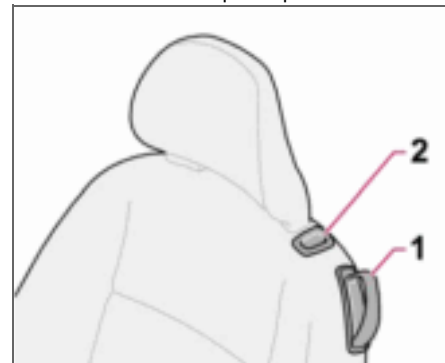

Easy entry

Move the seat backward:

- Press the button (2) located to the side of the head restraint. Keep it depressed.
- Move the handle (1) up and fold back the backrest.



Front seats

NOTE

The seat can only be moved to the very front (+6 cm) to facilitate entry and exit to and from the rear seat when the backrest has been folded forward. If the backrest is folded back when the seat is in the front position then the seat automatically moves back approx. 6 cm after a few seconds.

WARNING

Check that the backrest is properly folded back by pushing and pulling the head restraint.

The belt on the front passenger side must be in the belt guide during driving, even when there is no passenger sitting in the seat.

Floor mats (option)

Volvo supplies floor mats which are especially produced for your car.

WARNING

The floor mat at the driver's seat must be firmly fitted and secured in the attachment clips to prevent it from being trapped around and under the pedals.

Power seat (option)

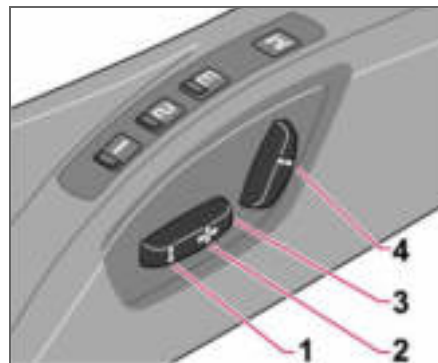

The seats can be adjusted for a certain time after unlocking the door with the remote control without the key being inserted into the ignition switch. The seat can always be adjusted in ignition position **I** or **II**.

1. Front edge of seat cushion up/down
2. Seat, forwards/backwards
3. Seat, up/down
4. Backrest rake

An overload protection is deployed if one of the seats is blocked. If this happens, turn off the ignition and wait a short time before adjusting the seat again. Only one of the seat's settings can be adjusted at a time.

Memory function

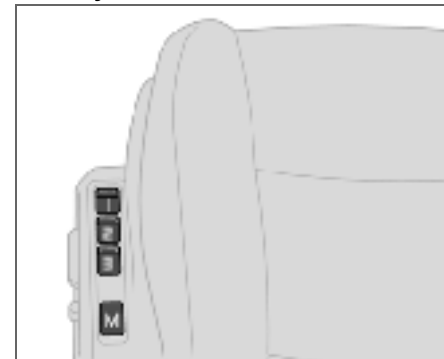

Buttons for memory function

Store setting

- Adjust seat.
- Press and hold button **M** while pressing button **1**, **2** or **3** simultaneously.

Using a stored setting

Press one of the memory buttons **1 – 3** until the seat stops. If you release the button then the movement of the seat will stop.



Interior lighting

Emergency stop

If the seat accidentally begins to move, press any of the buttons to stop the function.

⚠ WARNING

Risk of crushing. Make sure that children do not play with the controls. Check that there are no objects in front of, behind or under the seat during adjustment. Ensure that none of the rear seat passengers can be trapped.

Key memory in remote control key

The driver's seat settings are stored in the key memory when the car has been locked with the remote control key. When the car is unlocked with the same remote control the driver's seat adopts the stored settings when the driver's door is opened.

i NOTE

The key memory is independent of the seat memory.

Reading lamps and interior lighting

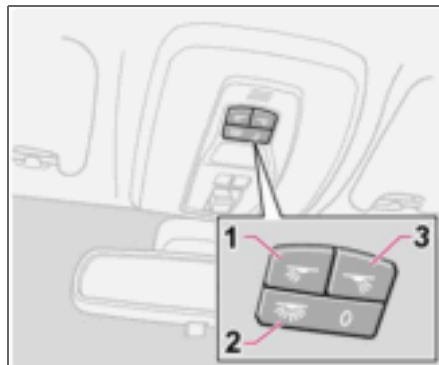

Passenger compartment lighting and reading lamps.

1. Reading lamp left-hand, On/Off
 2. Passenger compartment lighting front and rear
 3. Reading lamp right-hand, On/Off
- Switch (2) has three positions for the interior lighting:
- Off (0) – right-hand side depressed, automatic lighting off.
 - Neutral position – interior lighting comes on when a door is opened and goes out when the door is closed. The dimmer function is active.

- On – left-hand side depressed, passenger compartment lighting on.

The reading lamps can be switched on in ignition position I and II as well as when the engine is running. They can also be activated within 30 minutes after the engine has been switched off or when one of the doors has been opened/closed.

Cargo area lighting



Interior lighting in rear seat and cargo area.

Cargo area lighting includes a further lamp on the left-hand side of the cargo area.



Interior lighting

The interior and cargo area lighting illuminate when the tailgate is opened and remain on for 5 minutes.

The lighting is switched off:

- if the tailgate is closed
- if the button (2) is set in Off position (0).

Automatic lighting

The passenger compartment lighting is switched on and off automatically when button (2) is in neutral position.

The passenger compartment lighting is switched on and remains on for 30 seconds if:

- the car is unlocked from the outside with the key or remote control
- the engine is stopped and the ignition key is turned to position 0

The passenger compartment lighting is switched off when:

- the engine is started
- the car is locked from the outside with the key or remote control

The passenger compartment lighting comes on and remains on for 5 minutes if one of the doors is open.

The interior and cargo area lighting can be switched on or off within 30 minutes, from when the key is turned to position 0, with switch (2). The lighting remains on for 5 minutes if it is not switched off.

Vanity mirror¹

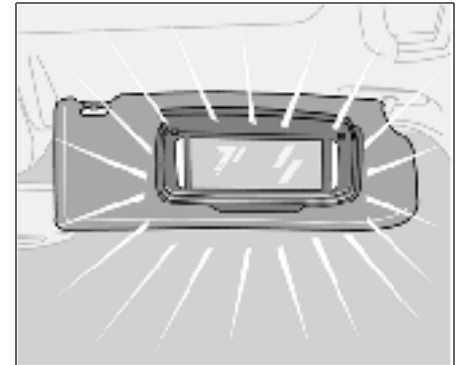

The light illuminates automatically when the cover is lifted.

¹ Option in certain markets.



Storage spaces in the passenger compartment

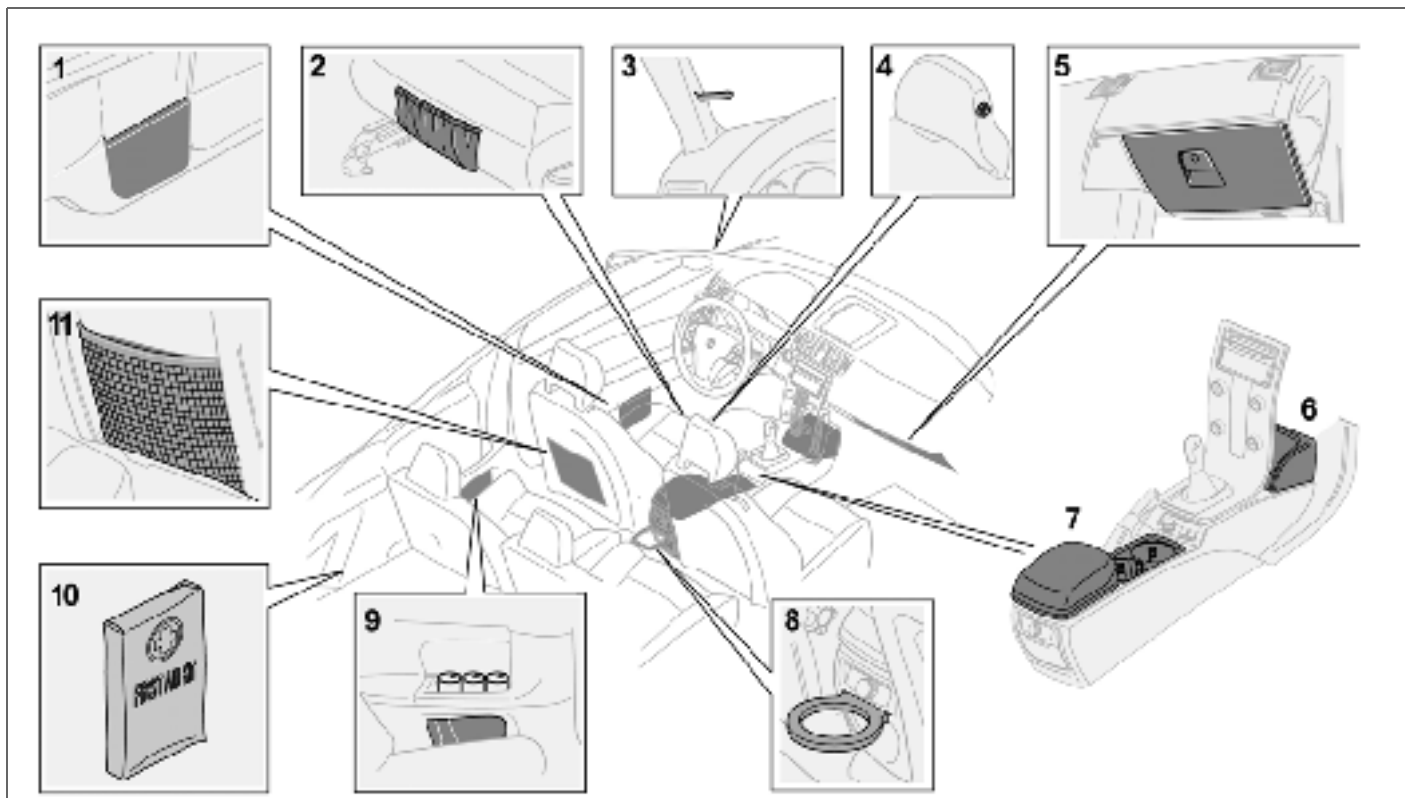



Storage spaces in the passenger compartment

Storage spaces

1. Storage compartments in doors
2. Storage pocket on front edge of front seat cushions (trim dependent)
3. Ticket clip
4. Coat hanger, only for light garments
5. Glovebox
6. Storage compartment
7. Storage compartment (e.g. for CD discs) and cup holder¹
8. Bottle holder (option)
9. Storage compartments in rear side panels with space for up to three soda cans
10. Storage compartment for first aid
11. Storage pockets for maps and magazines

WARNING

Ensure that no hard, sharp or heavy objects lie or protrude in such a way that they could cause injury during heavy braking.

Always secure large and heavy objects with a seatbelt or cargo retaining straps.

Glovebox

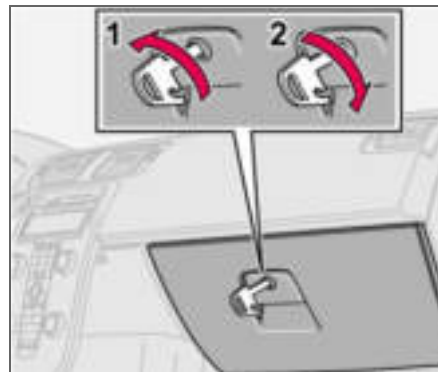

1. Unlocking
2. Locking

The owner's manual and maps can be kept here. There are also holders for coins, pens and fuel cards. The glovebox can be locked manually with the detachable key blade in the remote control. More information on the key blade is on page 95.

Floor mats (option)

Volvo supplies floor mats which are especially produced for your car.

WARNING

The floor mat at the driver's seat must be firmly fitted and secured in the attachment clips to prevent it from being trapped around and under the pedals.

¹ Storage compartment in certain markets.



Rear seat

Lowering the rear seat backrest



The rear seat backrests can be tipped forwards together, or individually, to make it easier to transport long objects.

Lowering the backrest:

- Pull the lock catch up and forward to release the backrest. A red indicator (A) shows that the backrest is no longer locked in place.
- Fold the backrest forward.

Raising the backrest:

- Fold up the backrest.
- Place the seatbelt over the backrest.
- Press the backrest backwards into locked position.
- Check that the backrest is locked.

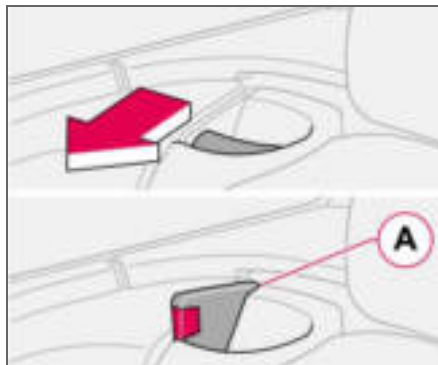

WARNING

Place the belt straps over the backrests before folding them back to their secured positions.

NOTE

When the backrest has been raised, the red indicator (A) should no longer be showing. If it is still showing then the backrest is not locked in place.

Armrest in the rear seat

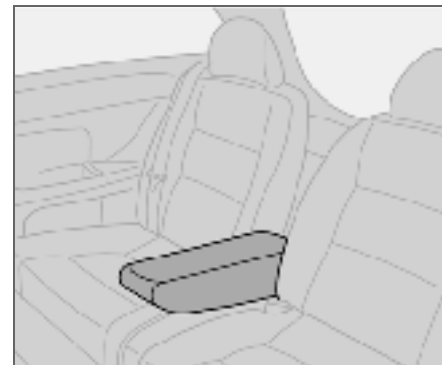

The armrest in the rear seat can be folded down for passenger comfort or to make space for a long load. The armrest folds down when one of the backrests is folded down.

For securing loads, see page 140.



Cargo area

Bottle holder (option)

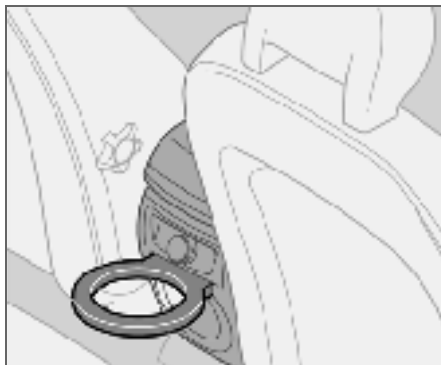

There is a bottle holder for larger bottles located to the rear of the tunnel console.

Soft cargo cover (option)

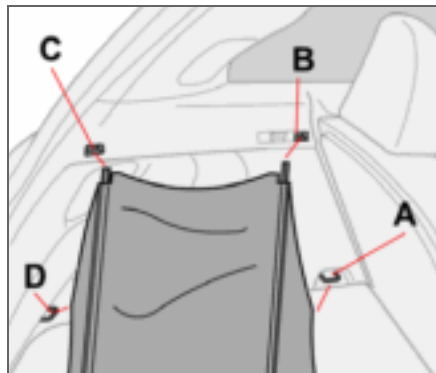

Soft cargo cover

The cargo cover is pulled over the luggage and secured in the rear load retaining eyelets. Undo (D) and, if necessary, (C) during loading.

Fitting the cargo cover

- Hook in the hooks in the front load retaining eyelets by the floor (A).
- Fit the front brackets in (B) by pressing together the spring-loaded rail and fit it into place on both sides.
- Fit the rear brackets in (C) in the same way.

- Hook in the hooks in the rear load retaining eyelets (D).

Hanging up the cargo cover when not in use

- Unhook the hooks from the rear load retaining eyelets (D).
- Press the rail together and remove it from the rear bracket (C). Place the rail at the front of the cargo area floor.
- Hook in the hooks in the rail next to the mounting points (B).

The cargo cover now hangs next to the rear seat backrest ready for the next time it is to be used.

Removing the cargo cover

- Unhook the hooks and remove one rail at a time by pressing them together and removing them from their mounting points.
- When all mounting points are detached the cargo cover can be rolled up and placed at the rear of the cargo area floor to make space for bulky loads.

i NOTE

The cargo cover has no load-securing function. Never load anything on top of the cargo cover. For securing loads, see page 140.



Cargo area

Hard cargo cover (option)

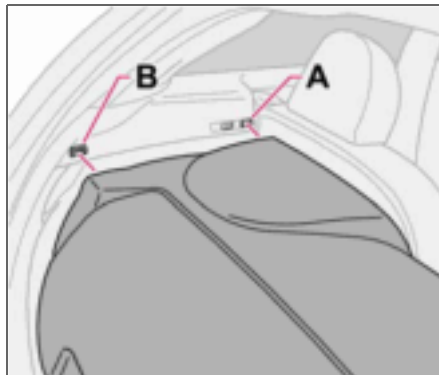
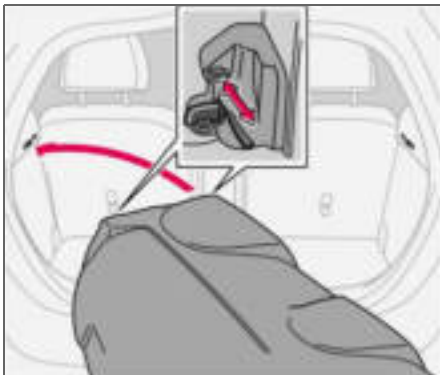

Locks and support pins

Fitting the cargo cover

- Retract all four lock plungers by pulling the lock buttons to their end positions before lifting in the cargo cover into the cargo area. The lock plungers stop in retracted position.
- Lift the cargo cover carefully into the cargo area sideways, turn it back around and angle the front edge up slightly.

- Locate the front section of the two support pins behind the active locks (A) on both sides.
- Align one of the rear locks at (B) and extend the lock plunger by moving the lock button forwards.
- Align the other rear lock in the same way and extend the lock plunger by moving the lock button forwards.
- Extend the front lock plungers, one at a time so that they lock in their active locks (A).

The cargo cover hatch can be raised during loading.

i NOTE

The cargo cover has no load-securing function. Never load anything on top of the cargo cover. For securing loads, see page 140.

Removing the cargo cover

- Retract the front lock plungers at (A) to their end positions by pulling back the lock buttons on both sides.
- Retract the rear lock plungers at (B) to their end positions by pulling back the lock buttons on both sides.
- Lift up and turn the cargo cover before lifting it from the cargo area.



Raising the floor hatch

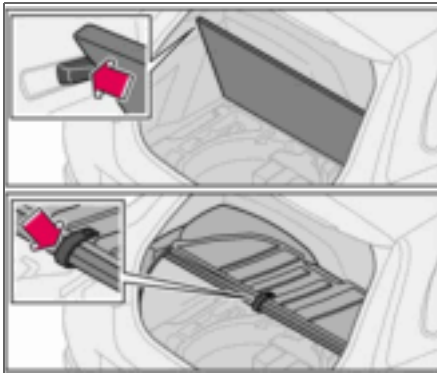

Without cargo cover

Raise the floor hatch and secure it in the lugs on both sides.

With hard cargo cover

Raise the hatch on the cargo cover. Then raise the floor hatch and hook it into the hook located under the cargo cover.



Cargo area

Safety net (option)

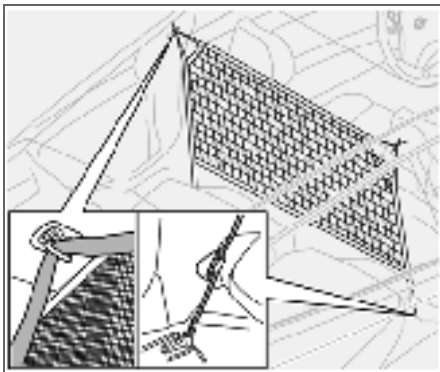

The safety net is located behind the front seat backrests. The safety net is only designed for use when the rear seat backrests are lowered. For securing loads, see page 140.

Fitting the safety net

- Fold down the backrests on both sides, see page 86.
- Secure the safety net in the roof panel mountings.
- Secure the hooks in the eyes at the seat-belt floor mounting on both sides.
- Stretch the straps if necessary.

- Check all mountings.

Removing the safety net

- Slacken the tension from the straps.
- Undo the hooks from the eyes at the seatbelt floor mounting on both sides.
- Detach the net from the mounting points in the roof panels.
- Fold up the safety net and store it in the bag.



WARNING

Cargo area loads must be well secured even if the safety net is correctly fitted.

Load retaining eyelets

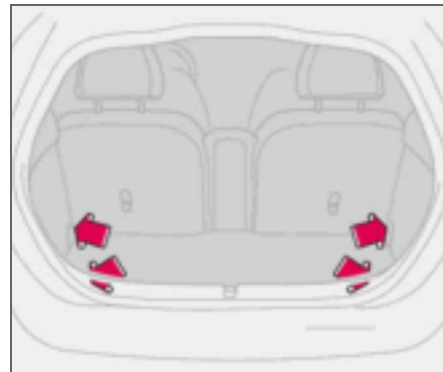

The load retaining eyelets¹ are used to fasten straps or nets to secure items in the cargo area.

There are two further eyelets on each side by the seatbelt slide rail that can be used for securing loads when the safety net is not in use.

For securing loads, see page 140.

¹ Option in certain markets.



04



| | |
|-------------------------------------|-----|
| Remote control with key blade | 94 |
| Keyless drive (option) | 98 |
| Locking and unlocking | 100 |
| Alarm (option) | 103 |

LOCKS AND ALARM



05



Remote control with key blade

Remote control

The car is supplied with two remote controls. They also serve as ignition keys. The remote controls contain detachable metal key blades for mechanical locking/unlocking of the driver's door and glovebox.

The key blades' unique code is available at authorised Volvo workshops, who can order new key blades.

A maximum of six remote controls/key blades can be programmed and used for one single car.

Flashing lock indicator for locking/unlocking

When the car is locked using the Keyless drive system or the remote control, one long flash signal of the direction indicators serves to indicate that locking was correctly performed. The indication is only given if all locks are activated once the doors have been closed. Correct unlocking is indicated by two short flashes.

Personal preferences can be used to deactivate indication via the direction indicators. There will then be no visual indication as to whether the lock status is correct. See page 64.

Loss of a remote control

If you lose a remote control, take the car and the other remote controls to an authorised Volvo workshop. The code of the missing remote control must be erased from the system as a theft prevention measure.

Immobiliser

The remote controls are fitted with coded chips. The code must be accepted by the reader (receiver) in the ignition switch. The car can only be started if the correct remote control with the correct code is used.

Remote control functions

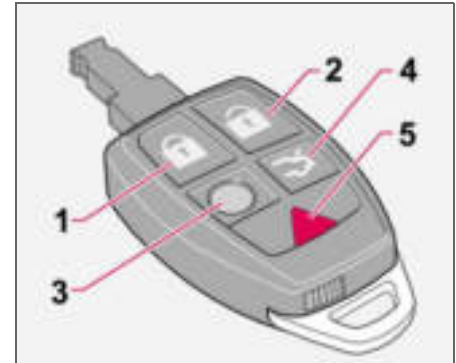

1. Locking – Locks both doors and the tailgate. Press and hold to also close the side windows and the sunroof if fitted.
2. Unlocking – Unlocks both doors and the tailgate.
3. Approach lighting – When you approach the car:
Press the yellow button on the remote control to switch on the interior lighting, position/parking lamps, number plate lighting and door mirror lamps (option). The lighting is switched off automatically after 30, 60 or 90 seconds. For information on setting the delay time, see page 65.



Remote control with key blade

4. Tailgate – Press the button once to unlock the tailgate only.

NOTE

The function does not open the tailgate.

5. Panic function – Used to attract attention in an emergency. Press and hold the red button for at least three seconds or press it twice within three seconds to activate the direction indicators and the horn. The function can be turned off with the same button once it has been active for at least 5 seconds. Otherwise the function switches off automatically after 30 seconds.

IMPORTANT

The narrow section of the remote control is particularly sensitive - this contains the chip. The car cannot be started if the chip is damaged.

Key blade

This feature is intended for when leaving the car, such as for servicing or valet parking at a hotel etc. Hand over the remote control and keep the detachable key blade.

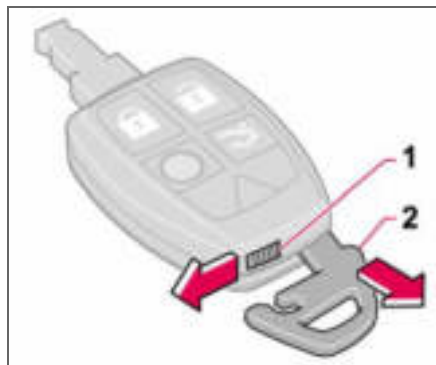

Removing the key blade

Take the key blade from the remote control:

- Slide the spring-loaded catch (1) to the side while pulling the key blade (2) out backwards.

Inserting the key blade

Be careful when inserting the key blade back into the remote control.

- Hold the remote control with the narrow end pointing down and lower the key blade into its slot.
- Lightly press the key blade to lock it in position. You should hear a "click".



Remote control with key blade

Key blade

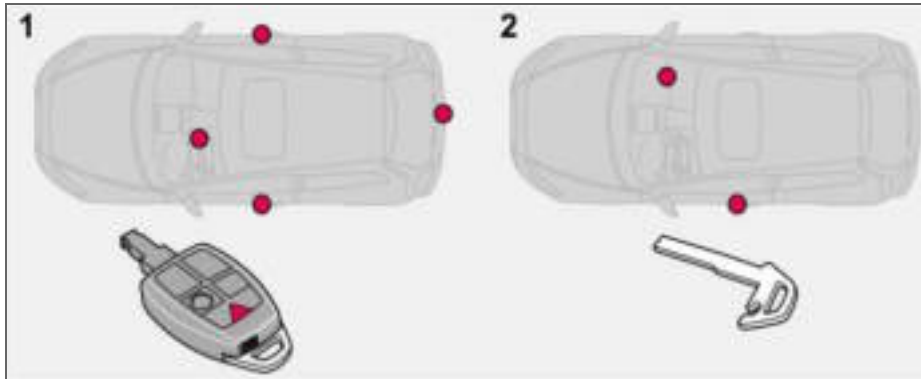

Active locks

1. Active locks, remote control
2. Active locks, key blade

The detachable key blade of the remote control is used to lock or unlock the glovebox or driver's door (without activating the central locking system).

NOTE

Using the detachable key blade of the remote control to unlock the driver's door will trigger the alarm. Switch off the alarm with the remote control. See page 104.



Remote control with key blade

Weak remote control battery

When the battery runs down and full functionality cannot be guaranteed, the information symbol and **REMOTE BATTERY LOW VOLTAGE** appear on the display.

Replacing the remote control battery

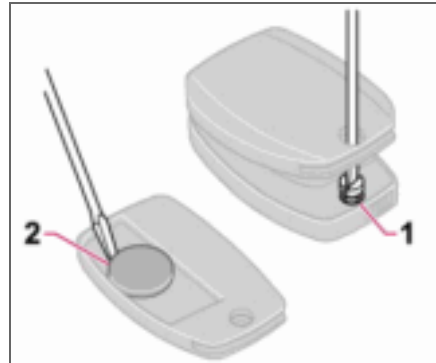

If the locks repeatedly fail to respond to signals from the remote control at a normal distance, the battery should be replaced (type CR 2032, 3 V).

- Pull out the key blade.
- Place the remote control with the keypad downward and remove the screw (1) using a small screwdriver.
- Remove the cover.
- Carefully note the position of the battery's + and - poles on the inside of the cover.
- Prise out (2) and change the battery. Avoid touching the battery and its terminals with your fingers.

- Refit the cover and screw it shut.
 - Press the key blade back into place.
- Dispose of the old battery in an environmentally-friendly way.



Keyless drive (option)

Keyless lock and ignition system

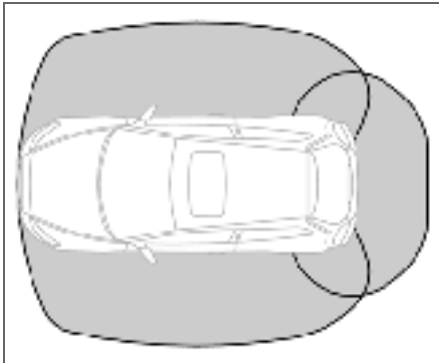

The keyless drive system allows the car to be unlocked, driven and locked without the need for a key. You simply need to have the remote control with you in a pocket or a bag.

The system makes it easier and more convenient to open the car, for example with shopping bags in one hand and a child in the other. It saves you having to take out or look for the remote control.

The two remote controls incorporate the keyless drive feature. You can order additional remote controls. The keyless drive system can handle up to six remote controls.

Remote control max. 1.5 m from the car

In order to open a door or the tailgate, a remote control must be no more than approx. 1.5 metres from the car door handle or tailgate.

This means that the person who wishes to open a door must have the remote control with him or her. It is not possible to open a door if the remote control is on the other side of the car.

The grey areas in the illustration indicate the range covered by the system's antennas.

If someone leaves the car and takes a keyless drive remote control with them, a warning message appears on the information display and a reminder signal sounds. The warning message disappears when the remote control is brought back to the car or when the ignition dial is turned to position **0**. The warning is only issued if the ignition dial is in position **I** or **II** after someone has opened and closed a door.

The warning message and reminder signal disappear when the remote control is brought back to the car after one of the following actions:

- a door has been opened and closed
- the ignition dial has been turned to position **0**

- the **READ** button has been pressed.

Never leave any remote control in the car

If a remote control with keyless drive function is left in the car, it is made passive when the car is locked. This prevents unauthorised entry.

If someone breaks into the car and finds the remote control, it can be activated and used again. It is therefore important to handle all remote controls with equal care.

Interference to remote control function

Electromagnetic screening and fields can interfere with the keyless drive system. To avoid this: do not place the remote control near mobile phones, metallic objects or, for example, in a metal briefcase.

If interference is experienced nonetheless, use the remote control and key blade in the normal way, see page 94.



Keyless drive (option)

Unlocking

When the remote control is within the range covered by the system's antennas:

- Open the doors by pulling the relevant handle.
- Open the tailgate by pressing under the tailgate opening button and lift the tailgate.

If for some reason the keyless drive function in the remote control is not operating, the car can be unlocked using the remote control functions, see page 94.

Unlocking using the key blade

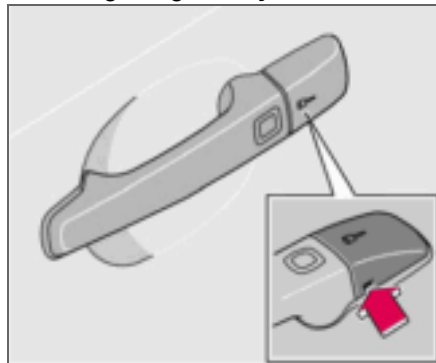

The driver's door can be opened as follows (central locking system not activated):

- Carefully prise out the plastic cover in the handle by inserting the key blade in the hole on the bottom of the cover.
- Unlock the door using the key blade.

Power seat (option) – remote control with memory function

If several people with keyless drive remote controls get into the car, then the driver's seat will be adjusted for the person who opens the door first.

Locking

Lock the doors and tailgate as follows:

- Push in the lock button on one of the door handles.

Both doors and the tailgate must be closed before the lock button can be pressed. Otherwise they will not lock.

When the car is locked, the lock buttons on the inside of the doors retract.

Personal preferences

The Keyless Drive system can have personal preferences applied, see page 65.



Locking and unlocking

Locking/unlocking the car from outside

Unlocking

The remote control unlock button can unlock the car in two different ways (select option in personal preferences, see page 65):

- with one press unlock both doors and the tailgate
- with one press unlock the driver's door and with a second press unlock the other door and the tailgate.

Locking

The remote control locks both doors and the tailgate simultaneously. Door lock buttons and inside door handles are disengaged.

The fuel filler flap cannot be opened if the car is locked with the remote control.



NOTE

The car can be locked¹ even if a door or the tailgate is open. When the door is closed there is a risk that the keys will be locked in.

¹Applies to certain markets



WARNING

Be aware that you can be locked in the car if it is locked from the outside with the remote control. You cannot then leave the car using any of the controls inside the car.

Automatic relocking

If none of the doors or the tailgate is opened within two minutes of unlocking, all are locked again automatically (does not apply to locking from inside). This function reduces the risk of the car being left unlocked unintentionally. For cars with alarms, see page 104.

Automatic locking

When the speed of the car exceeds 7 km/h the doors and tailgate can be locked automatically.

When the function is activated and the doors have been locked they can be opened in two ways:

- pull one of the door handles twice
- press the unlock button by the door handle.

The function can be activated/deactivated by means of personal preferences, see page 65.

Tailgate

Unlocking

Unlocking tailgate only:

- Press the remote control button to unlock the tailgate.

Locking

If the doors are locked when the tailgate is closed then it remains unlocked. Lock with the remote control or from inside to lock both doors and the tailgate.



Locking and unlocking

Locking/unlocking from inside

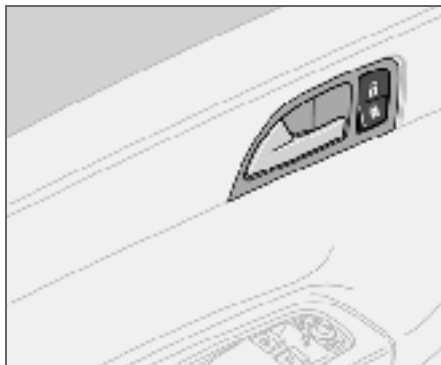

The doors and the tailgate can be locked or unlocked simultaneously using the lock button by the door handle.

Unlocking

- Press the upper section of the lock button. Press and hold to also open all side windows.

Locking

- Press the lower section of the lock button. Press and hold to also close all of the windows and the sunroof if fitted.

Both doors and tailgate are locked with the lock button in the driver's or passenger door.

Opening the doors

When the doors are locked from the inside:

- Pull the handle twice to unlock and open the doors.

Locking the glovebox

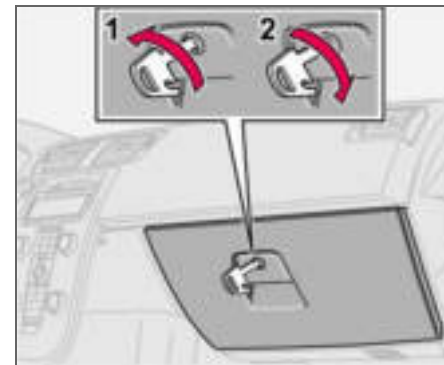

The glovebox can only be locked and unlocked with the detachable key blade in the remote control.

- Unlock the glovebox (1) by turning the key a quarter of a turn (90 degrees) anticlockwise. The keyhole is vertical in the unlocked position.
- Lock (2) the glovebox by turning the key a quarter of a turn (90 degrees) clockwise. The keyhole is horizontal in the locked position.



Locking and unlocking

Deadlocks

When deadlocked, the doors cannot be opened from the inside if they are locked. This is activated with the remote control. The deadlocks are set after a 25 second delay after the doors are locked.

The car can only be unlocked from the deadlock mode with the remote control. The doors can also be opened from the outside with the key.

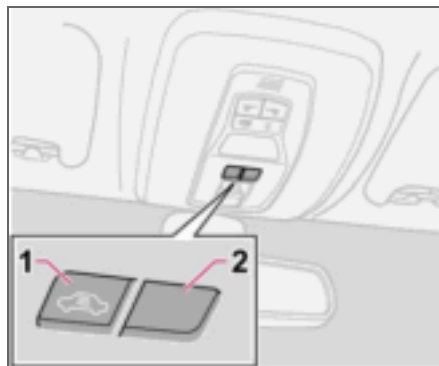

1. Deactivation of the detectors and deadlocks
2. No function

Temporary deactivation of the deadlocks and any alarm detectors

If someone is going to stay in the car but you still want to lock the doors from the outside, the deadlocks can be disabled.

- Insert the key into the ignition switch, turn it to position **II** and then back to position **I** or **0**.
- Press the button (1).

If the car is equipped with an alarm, the movement and tilt detectors are also deactivated at the same time, see page 104.

The light in the button illuminates until the car is locked with the key or the remote control. A message remains on the display as long as the key remains in the ignition switch. The detectors are reactivated and deadlocks re-engaged the next time the ignition is switched on.



WARNING

Do not allow anyone to remain in the car without first deactivating the deadlocks.

**Alarm (option)****Alarm system**

When the alarm is armed, it continually monitors all alarm inputs.

The alarm is triggered if:

- a door, the bonnet or tailgate opens
- a non-approved key is used in the ignition or if an attempt is made to force the lock
- a movement is detected in the passenger compartment (if fitted with a movement detector)
- the car is raised or towed away (if fitted with a tilt detector)
- a battery cable is disconnected
- anyone tries to disconnect the siren.

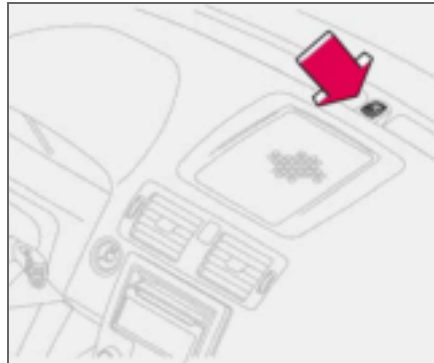
Alarm lamp on instrument panel

A light on the instrument panel indicates the alarm system's status:

- Lamp not lit – the alarm is not armed.
- The lamp flashes rapidly after disarming the alarm and until the ignition is switched on – the alarm has been triggered.
- The lamp flashes once every other second after the car's direction indicators have given one long flash – the alarm is armed.

If there is a fault in the alarm system, a message appears on the information display. Contact an authorised Volvo workshop.

NOTE

Do not attempt to repair or modify alarm system components. All such attempts could affect the terms of insurance.

Arming the alarm

- Press the lock button on the remote control. A long flash from the car's direction indicators confirms that the alarm is armed and that all the doors are locked.

IMPORTANT

The alarm is fully armed when the car's direction indicators have made one long flash and the light on the dashboard flashes once per second.

Disarming the alarm

- Press the unlock button on the remote control. Two short flashes from the car's direction indicators confirms that the alarm is disarmed and that both doors are unlocked.



Alarm (option)

Automatic alarm activation

This function prevents you accidentally leaving the car without the alarm on.

If none of the doors or the tailgate are opened within two minutes of disarming the alarm (and the car has been unlocked with the remote control), the alarm is automatically rearmed. The car is locked at the same time.

Deactivating a triggered alarm

- Press the unlock button on the remote control or insert the key in the ignition switch.

Confirmation is given by two short flashes from the direction indicators.

Alarm signals

When the alarm is triggered, the following happens:

- A siren sounds for less than 25 seconds. The siren has its own battery which is used if the car battery has insufficient charge or is disconnected.
- The direction indicators flash for five minutes or until the alarm is deactivated.

Remote control not working

If for some reason the remote control is not working, the alarm can still be switched off and the car started as follows:

- Open the driver's door with the key blade. The alarm is triggered and the siren sounds.
- Insert the remote control into the ignition switch. The alarm is deactivated. The alarm lamp flashes rapidly until the ignition key is turned to position II.

Temporary deactivation of the deadlocks and alarm detectors

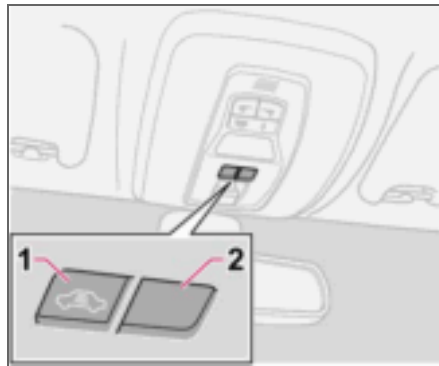

1. Deactivation of the detectors
2. No function

To prevent the alarm being triggered erroneously, such as during a ferry journey, the movement and tilt detectors can be temporarily disengaged.

- Turn the ignition key to position II and then back to position 0. Remove the key.
- Press button (1). The lamp in the button is illuminated until the car is locked.

A message remains on the display as long as the key remains in the ignition switch (or for one minute after the key is removed).

The detectors are reactivated the next time the ignition is switched on.

If the car has deadlocks, these are also re-engaged.

**Alarm (option)****Testing the alarm system****Testing the movement detector in the passenger compartment**

- Open all windows.
- Arm the alarm. Activation of the alarm is confirmed by the lamp flashing slowly.
- Wait 30 seconds.
- Test the movement detector in the passenger compartment, such as by lifting out a bag from a seat. A siren should sound and all direction indicators should flash.
- Deactivate the alarm by unlocking the car with the remote control.

Testing the doors

- Arm the alarm.
- Wait 30 seconds.
- Unlock the driver's door with the key blade.
- Open one of the doors. A siren should sound and all direction indicators should flash.
- Deactivate the alarm by unlocking the car with the remote control.

Testing the bonnet

- Sit in the car and deactivate the movement detector.

- Arm the alarm. Remain in the car and lock the doors with the button on the remote control.
- Wait 30 seconds.
- Open the bonnet with the handle under the dashboard. A siren should sound and all direction indicators should flash.
- Deactivate the alarm by unlocking the car with the remote control.

| | |
|--|-----|
| General | 108 |
| Refuelling | 110 |
| Starting the engine | 111 |
| Keyless drive (option) | 113 |
| Manual gearbox | 114 |
| Automatic gearbox | 116 |
| Brake system | 119 |
| Stability and traction control system | 121 |
| Parking assistance (option) | 123 |
| Blind Spot Information System BLIS (option) | 125 |
| Towing and recovery | 128 |
| Jump starting | 130 |
| Driving with a trailer | 131 |
| Towing bracket | 133 |
| Detachable towbar | 135 |
| Loading | 140 |
| Adjusting headlamp pattern | 141 |

STARTING AND DRIVING



06



General

Economical driving

Driving economically means driving smoothly while thinking ahead and adjusting your driving style and speed to the prevailing conditions.

- Get the engine warmed up as soon as possible.
- Do not let the engine idle, but drive at light loads as soon as it is possible. A cold engine consumes more fuel than a warm one.
- Avoid sudden unnecessary acceleration and heavy braking.
- Do not drive with unnecessary loads in the car.
- Do not use winter tyres when the roads are dry.
- Remove the load carrier when it is not in use.
- Avoid driving with open windows.

Slippery driving conditions

Practise driving on slippery surfaces under controlled conditions to learn how the car reacts.

Engine and cooling system

Under special conditions, for example when driving in hilly terrain, extreme heat or with

heavy loads, there is a risk that the engine and cooling system will overheat.

Avoid overheating the cooling system

- Maintain a low speed when driving with a trailer up long, steep ascents.
- Do not turn the engine off immediately you stop after a hard drive.
- Remove any auxiliary lamps from in front of the grille if driving in extreme high temperatures.

Avoid overheating the engine

Do not exceed engine speeds of 4500 rpm (diesel engines: 3500 rpm) if driving with a trailer or caravan in hilly terrain. The oil temperature could then become too high.

Open tailgate

Avoid driving with the tailgate open. If it is necessary to drive with the tailgate open for a short distance:

- Close all windows.
- Set the air distribution to the windscreen and floor and run the fan at high speed.



WARNING

Do not drive with the tailgate open. Toxic exhaust fumes can be drawn into the car through the cargo area.

Driving in water

The car can be driven through water at a maximum depth of 25 cm at a maximum speed of 10 km/h. Extra caution should be exercised when passing through flowing water.



IMPORTANT

Engine damage can occur if water enters the air filter. In greater depths, water can enter the transmission. This reduces the lubricating ability of the oils and shortens the service life of the systems.

When driving in water, maintain a low speed and do not stop the car. When the water has been passed, depress the brake pedal lightly and check that full brake function is achieved. Water and mud for example can make the brake linings wet resulting in delayed brake function.

Clean the electric contacts of the electric engine block heater and trailer coupling after driving in water and mud.

**IMPORTANT**

Do not let the car stand with water over the sills for any long period of time. This could cause electrical malfunctions.

In the event of stalling in water, do not try to restart. Tow the car from the water.

Do not overload the battery

The electrical functions in the car load the battery to varying degrees. Avoid having the ignition key in position **II** when the engine is turned off. Use ignition position **I** instead, as less power is consumed.

Examples of functions that use a lot of power:

- ventilation fan
- windscreen wipers
- audio equipment (high volume)
- parking lamps

Also, be aware of different accessories that load the electrical system. Do not use functions which use a lot of power when the engine is switched off.

If the battery voltage is low, a message appears on the display. The energy-saving function shuts down certain functions or reduces the load on the battery by, for example, slowing the ventilation fan and switching off the audio system. Charge the battery by starting the engine.



Refuelling

Opening the fuel filler flap



Switch off the fuel-driven heater before refuelling.

Open the fuel filler flap with the button on the lighting panel, see page 47. The engine must be switched off before the flap can be opened. The fuel flap is located on the rear right wing.

Closing

Push in the flap until you hear a click.

Fuel cap

1. Turn the fuel cap until an obvious resistance is felt.

2. Turn past the resistance until it comes to a stop.
3. Take out the cap.
4. Hang up the cap on the inside of the fuel filler flap.

NOTE

Put the petrol cap back on after refuelling. Turn until one or more clear clicks are heard.

Filling up with fuel

Do not overfill the tank but fill until the pump nozzle cuts out.

NOTE

Excess fuel in the tank can overflow in hot weather.

Fuel of a lower quality than that specified on page 233 should not be used as engine power and fuel consumption can be negatively affected.

WARNING

Fuel which spills onto the ground can be ignited by the exhaust fumes.

Switch off the fuel-driven heater before starting to refuel.

Never carry an activated mobile phone when refuelling. The ring signal could cause spark build-up and ignite petrol fumes, leading to fire and injury.

Petrol

IMPORTANT

Do not add cleaning additives to the petrol, unless recommended by Volvo.

Diesel

At low temperatures ($-5\text{ }^{\circ}\text{C}$ to $-40\text{ }^{\circ}\text{C}$), a paraffin precipitate may form in the diesel fuel, which can lead to ignition problems.

IMPORTANT

Use special winter grade fuel during cold months.



Starting the engine

Before starting the engine

- Apply the parking brake.

Automatic gearbox

- Gear selector in position **P** or **N**.

Manual gearbox

Put the gear lever in neutral and hold the clutch pedal fully depressed. This is particularly important in very cold conditions.

WARNING

Never remove the ignition key from the steering lock while driving or when the car is being towed. The steering lock could otherwise be activated, making it impossible to steer the car.

The ignition key must be in position **II** when the car is being towed.

NOTE

The idling speed can be noticeably higher than normal for certain engine types during cold starting. This is in order that the emissions system can reach normal operating temperature as quickly as possible, which minimises exhaust emissions and protects the environment.

Starting the engine

Petrol

- Turn the ignition key to position **III**.
If the engine does not start within 5–10 seconds, release the key and try again.

Diesel

1. Turn the ignition key to position **II**.
An indicator symbol in the combined instrument panel shows that engine preheating is underway, see page 41.
2. Turn the ignition key to position **III** when the indicator symbol goes out.

Autostart (5-cylinder)

With the autostart function, there is no need to hold the ignition key (or ignition dial on cars with Keyless Drive, see page 113) in position **III** until the engine has started.

Turn the ignition key to the start position and then release. The starter motor then works automatically until the engine has started.

NOTE

If the diesel engine is started in extreme cold without waiting for engine preheating, then the automatic start sequence can be delayed for a couple of seconds.

Diesel particle filter (DPF)

Diesel cars are equipped with a particle filter, which results in more efficient emission control. The particles in the exhaust gases are collected in the filter during normal driving. So-called "regeneration" is started in order to burn away the particles and empty the filter. This requires the engine to have reached normal operating temperature.

Regeneration of the filter takes place automatically at an interval of approximately 300 – 900 km depending on driving conditions. Regeneration normally takes between 10 and 20 minutes. During this time fuel consumption may increase slightly.

The rear window heating may be activated automatically to increase the load on the engine during regeneration without warning.

Regeneration in cold weather

If the car is frequently driven short distances in cold weather then the engine does not reach normal operating temperature. This means that regeneration of the diesel particle filter does not take place and the filter is not emptied.

When the filter has become approximately 80 % full of particles, a yellow warning triangle illuminates on the dashboard, and the



Starting the engine

message, **SOOT FILTER FULL SEE MANUAL** is shown on the dashboard display.

Start regeneration of the filter by driving the car until the engine reaches normal operating temperature, preferably on a main road or motorway. The car should then be driven for approximately 20 minutes more. When regeneration is underway the engine power is reduced.

When regeneration is complete the warning message is cleared automatically.

IMPORTANT

If the filter fills up it may be incapable of functioning. Then it can be difficult to start the engine and there is a risk that the filter will have to be replaced.

Use the parking heater (option) in cold weather so that the engine reaches normal operating temperature more quickly.

Ignition keys and electronic immobiliser

The ignition key must not hang with other keys or metal objects on the same key ring. The electronic immobiliser could be activated accidentally.

Ignition switch and steering lock

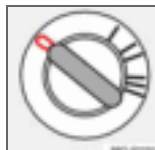

0 – Locked position

The steering lock is activated when the key is removed from the lock.



I – Radio position

Certain electrical components can be switched on. The engine's electrical system is not activated.



II – Driving position

The key position when driving. The car's electrical system is energised.



III – Start position

The starter motor is engaged. When the key is released it springs back automatically to the driving position, once the engine has started.

A ticking sound may be heard if the key is between positions. Turn the key to position **II** and back to eliminate the sound.

When the steering lock is activated

If the front wheels are positioned so that there is tension in the steering lock, a warning message may be shown on the information display and the car prevented from starting.

1. Remove the key and turn the steering wheel to release the tension.
2. Hold the steering wheel in this position. Reinsert the key and make a new attempt to start the car.

WARNING

Never remove the ignition key from the ignition switch while driving or when the car is being towed. The steering lock would be activated, making it impossible to steer the car.

WARNING

Always remove the ignition key from the ignition switch when leaving the car, especially if there are children in the car.

Make sure the steering lock is activated when the car is left to reduce the risk of theft.



Keyless drive (option)

General

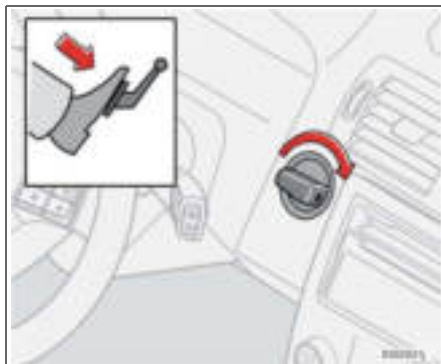

The keyless drive function allows the car to be unlocked, driven and locked without the need for a key, see page 98.

The ignition switch ignition dial is used in the same way as the key. One precondition for starting the car is that the car's remote control is located inside the passenger compartment or the cargo area.

Starting the car

- Depress the clutch pedal (cars with manual gearbox) or brake pedal (cars with automatic gearbox).

Petrol engine

- Press in and turn the ignition dial to position **III**.

Diesel engine

1. First turn the ignition dial to position **II** and wait until the diesel indicator symbol in the combined instrument panel goes out, see page 41.
2. Following which, turn the ignition dial to position **III**.

Starting with the remote control



If the remote control battery is discharged then the Keyless Drive function does not work. In which case, start the car by using the remote control as ignition dial.

1. Press in the catch in the ignition dial and then pull it out from the ignition switch.
2. Insert the remote control into the ignition switch and start in the same way as with the ignition dial.



Manual gearbox

Gear positions, five-speed



Depress the clutch pedal fully during each gear change. Take your foot off the clutch pedal between gear changes. Follow the shifting pattern indicated.

For the best possible fuel economy, use the highest gear possible as often as possible.

Reverse gear inhibitor, five-speed



Only engage reverse gear when the car is stationary. To engage reverse gear, the gear lever must first be put in position **N**. Reverse gear cannot therefore be engaged directly from fifth gear due to the reverse gear inhibitor.

Gear positions, six-speed (petrol)

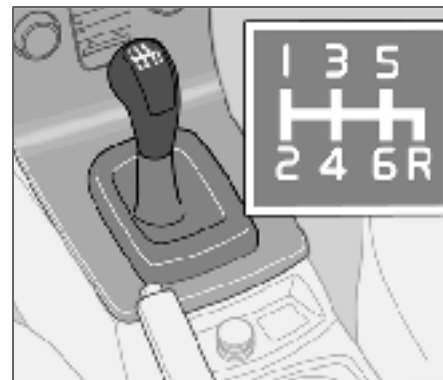

Depress the clutch pedal fully during each gear change. Take your foot off the clutch pedal between gear changes. Follow the shifting pattern indicated.

For the best possible fuel economy, use the highest gear possible as often as possible.

It can be difficult to find the positions for fifth and sixth gear when the car is stationary as the reverse gear inhibitor (which blocks sideways movement towards reverse) is then not activated.



Manual gearbox

Reverse gear inhibitor, six-speed (petrol)



Only engage reverse gear when the car is stationary.

i NOTE

Reverse gear is electronically blocked if the car is travelling faster than approx. 20 km/h.

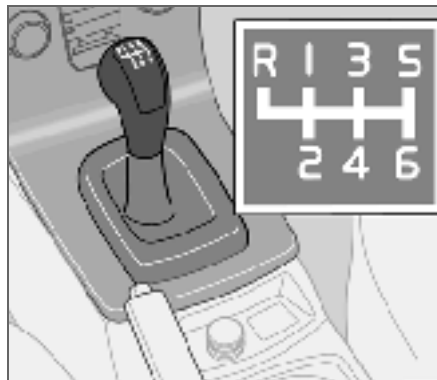
Gear positions, six-speed (diesel)¹

Depress the clutch pedal fully during each gear change. Take your foot off the clutch pedal between gear changes. Follow the shifting pattern indicated. For the best possible fuel economy, use the highest gear possible as often as possible.

Reverse gear inhibitor, six-speed (diesel)

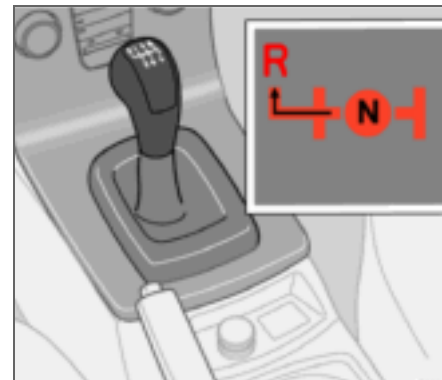

Only engage reverse gear when the car is stationary. Engage reverse gear by pressing down the gear lever and moving it to the left.

06

¹ Certain markets.



Automatic gearbox

Cold start

When starting in low temperatures, the gear changes can sometimes feel hard. This is due to the gearbox oil's viscosity at low temperatures. To reduce engine emissions, the gearbox shifts up later than normal when the engine is started at low temperatures.

NOTE

Depending on the engine temperature when the engine is started, the idle speed after a cold start may be higher than normal for certain engine types.

Kick-down

When the accelerator pedal is pressed all the way to the floor, beyond the position normally regarded as full acceleration, a lower gear is immediately engaged. This is known as kick-down.

If the accelerator is released from the kick-down position, the gearbox automatically changes up.

Kick-down is used when maximum acceleration is needed, such as for overtaking.

To prevent overrevving, the gearbox control program has a protective downshift inhibitor which prevents the kick-down function.

The kick-down function cannot be used in manual gear position (Geartronic).

Safety systems

Cars with an automatic gearbox have special safety systems:

Keylock

To remove the ignition key, the gear selector must be in the **P** position. The key is locked in all other positions.

Parking position (P position)

Stationary car with engine running:

- Hold your foot on the brake pedal when moving the gear selector to another position.

Electric gear inhibitor – Shiftlock

Parking position (P position)

To be able to move the gear selector from the **P** position to other gear positions, the ignition key must be in position **II** and the brake pedal must be depressed.

Shiftlock – Neutral (N position)

If the gear selector is in the **N** position and the car has been stationary for at least three seconds (irrespective of whether the engine is running) then the gear selector is locked in the **N** position.

To be able to move the gear selector from the **N** position to another gear position, the brake pedal must be depressed and the ignition key must be in position **II**.

Disengaging shiftlock

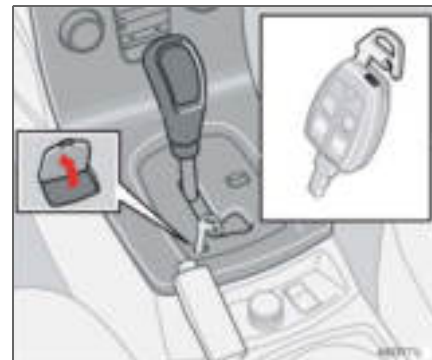

In certain cases, it may be necessary to move the car when it is not driveable, for example if the battery is flat. Proceed as follows to move the car:

1. There is a small cover below the **P-R-N-D** text on the gear selector panel. Open it at the rear edge.
2. Fully insert the key blade from the remote control.
3. Hold the key blade down and at the same time move the gear lever out of the **P** position.



Automatic gearbox

Mechanical gear selector inhibitor

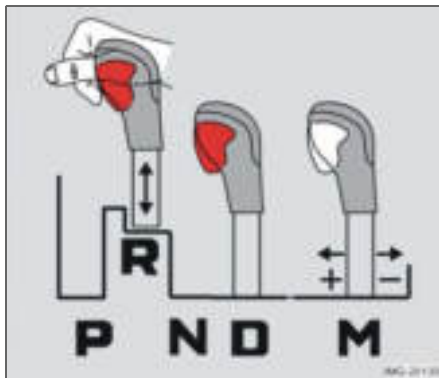

The gear selector can be moved freely between **N** and **D**. Other positions are locked with a latch that is released with the inhibitor button on the gear selector.

The gear selector can be moved between the different gear positions by pressing the inhibitor button.

Automatic gear positions

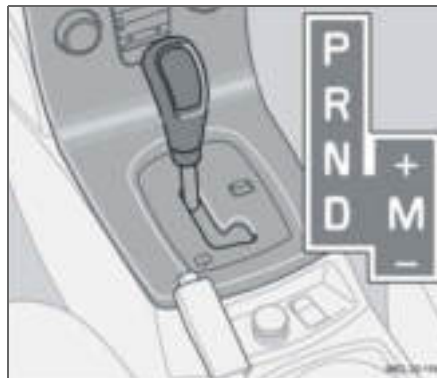

P – Parking position

Select position **P** when you wish to start the engine or park the car.

! IMPORTANT

The car must be stationary when position **P** is selected.

i NOTE

The brake pedal must be depressed to move the gear selector from the **P** position.

The gearbox is mechanically blocked when the **P** position is engaged. Always apply the parking brake when parking the car.

R – Reverse

The car must be stationary when **R** is selected.

N – Neutral

N is the neutral position. No gear is engaged and the engine can be started. Apply the parking brake when the car is stationary with the gear selector in position **N**.

D – Drive

D is the normal driving position. Shifting up and down between the different gearbox ratios occurs automatically based on the level of acceleration and speed. The car must be stationary when the gear selector is moved to position **D** from position **R**.



Automatic gearbox

Manual positions

To move from the automatic driving position **D** to a manual position, move the gear selector to position **M**. To go from position **M** to the automatic driving position **D**, move the selector to position **D**.

While driving

The manual gearshift mode can be selected at any time while driving. The engaged gear is locked until you choose another gear.

If the gear selector is moved to – (minus) the car changes down a gear and engine brakes at the same time as the accelerator pedal is released. If the gear selector is moved to + (plus) the car changes up a gear.

The selected gear is indicated on the combined instrument panel, see page 39.



NOTE

Geartronic contains two safety functions:

- Geartronic does not permit downshifting/kick-down which would result in an engine speed high enough to damage the engine. Nothing happens if the driver tries to shift down in this way. The original gear remains engaged.

- Geartronic automatically shifts down if the driver allows the speed to decrease lower than a level suitable for the selected gear, in order to avoid jerking and stalling.

W – Winter



The **W** button is used to activate and deactivate the winter program **W**. Display of the **W** symbol in the combined instrument panel indicates that the winter program is active.

The winter program starts the gearbox in a higher gear to facilitate starting off on slippery surfaces. The lower gears are only activated with kick-down when the winter program is engaged.

The **W** program can be selected regardless of the position of the gear selector, but is only operational when the selector is in position **D**.

To prevent overrevving, the gearbox control program has a protective downshift inhibitor.



Brake system

Brake servo

If the car is rolling or is being towed with the engine turned off, the brake pedal must be pressed about five times harder than when the engine is running. If the brake pedal is depressed when the engine is started, you will feel the pedal drop. This is normal and due to the brake servo becoming active. This may be more noticeable if the car has Emergency Brake Assistance (EBA).

WARNING

The brake servo only works when the engine is running.

NOTE

If braking with the engine switched off, press the brake pedal sharply once, not repeatedly.

Brake circuits



This symbol lights if a brake circuit is not working.

If a fault should occur in one of the circuits, it is still possible to brake the car. The brake pedal will travel further and may feel softer than normal. Harder pressure on the pedal is needed to produce the normal braking effect.

Dampness can affect braking characteristics

Brake components become wet when the car is driven in heavy rain, through pools of water or when the car is washed. This may alter brake pad friction characteristics so that there is a delay before braking effect is noticed.

Press the brake pedal lightly from time to time if driving for long stretches in rain or slushy snow, as well as after setting off in very damp or cold weather. This warms up the brake pads and dries off any water. This precaution is also recommended before parking the car for a long period in such weather conditions.

If the brakes are used heavily

When driving in the Alps or other roads with similar characteristics, the car's brakes are heavily loaded even if the brake pedal is not being depressed especially hard.

Because speed is often low, the brakes are not cooled as effectively as when driving on flat roads at high speed.

So as not to overload the brakes, shift down when driving downhill instead of using the foot brake. Use the same gear driving downhill as you would use driving uphill. This uses

engine braking more efficiently so the foot brake is only required for brief periods.

Bear in mind that driving with a trailer puts an additional load on the car's brakes.

Anti-lock braking system (ABS)



The anti-lock braking system (ABS) prevents the wheels from locking up during braking.

This means the ability to steer is maintained and it is easier to swerve to avoid a hazard for example.

After the engine has been started, the ABS will perform a brief self-test at a speed of about 20 km/h. This can be felt and heard as pulses in the brake pedal.

To get the most out of the ABS:

1. Depress the brake pedal with full force. Pulses will be felt.
2. Steer the car in the direction of travel. Do not release the pressure on the pedal.

Practice braking with the ABS system in a traffic-free area and in different weather conditions.

The ABS symbol illuminates for two seconds if there was a fault in the ABS system when the engine was last running.



Brake system

Emergency brake assistance – EBA

(Emergency Brake Assistance) For sudden braking, full-strength braking is provided instantaneously. The EBA function senses when heavy braking is underway by registering how quickly the brake pedal is depressed. Continue braking without easing off on the brake pedal. The function is suspended when the pressure on the brake pedal eases. This function is always active. It cannot be disengaged.

NOTE

When EBA is activated the brake pedal lowers slightly more than usual, depress (hold) the brake pedal as long as necessary. If the brake pedal is released then all braking ceases.

WARNING

If the BRAKE and ABS warning symbols illuminate at the same time, there may be a fault in the brake system. If the level in the brake fluid reservoir is normal at this stage, drive carefully to the nearest authorised Volvo workshop and have the brake system checked.

If the brake fluid is under the MIN level in the brake fluid reservoir, do not drive further before topping up the brake fluid.

The reason for the loss of brake fluid must be investigated.



Stability and traction control system

General

The Dynamic Stability and Traction Control system (STC/DSTC) improves the car's traction and helps the driver to avoid skidding.

A pulsing sound may be noticed during braking or acceleration when the system is in action. The car may accelerate slower than expected when the accelerator pedal is depressed.

The car is equipped with either STC or DSTC depending on market. The table shows the integral functions of the respective systems.

| Function/system | STC | DSTC |
|-------------------------|-----|------|
| Active Yaw Control | | X |
| Spin Control | X | X |
| Traction control system | X | X |

Active Yaw Control

The function limits the driving and brake force of the wheels individually in order to stabilise the car.

Spin Control

The function prevents the driving wheels from spinning against the road surface during acceleration.

Traction control system

The function is active at low speed and transfers power from the driving wheel that is spinning to the one that is not.

Reduced operation

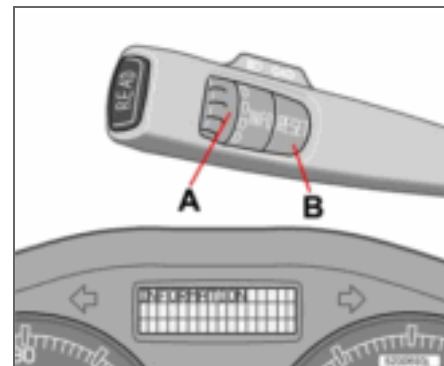

The stability system is activated automatically each time the car is started.

System operation during skidding and acceleration can be partially deactivated.

Operation during skidding is delayed and so allows more skidding which provides greater freedom for dynamic driving.

Traction in deep snow or sand is improved as acceleration is no longer limited.

Operation

- Turn thumbwheel (A) until the STC/ DSTC menu is shown.



Stability and traction control system

DSTC ON means that the system function is unchanged.

DSTC SPIN CONTROL OFF means that system operation is reduced.

- Press and hold **RESET** (B) until the DSTC menu is changed.

At the same time the symbol  illuminates as a reminder that the system has been reduced. The system remains reduced until the engine is next started.



WARNING

Suppressing system function may alter the driving characteristics of the car.



NOTE

DSTC ON is shown for several seconds in the display and the  symbol illuminates each time the engine is started

Messages in the information display

TRACTION CONTROL TEMPORARILY OFF means that the system has been temporarily reduced due to excessive brake disc temperature.

The function is reactivated automatically when the brakes have cooled.

ANTI-SKID SERVICE REQUIRED means that the system has been disabled due to a fault.

- Stop the car in a safe place and turn off the engine.

If the message remains when the engine is restarted, drive to an authorised Volvo workshop.



Symbols in the combined instrument panel

DSTC system



Information



If the symbols  and  are displayed at the same time, read the message on the information display.

If the symbol  appears alone then it may appear as follows:

- Flashing light means that the STC/DSTC system is now being activated.
- Constant glow for two seconds means system check when the engine is started.
- Constant glow after starting the engine or while driving means a STC/DSTC system fault.

- Constant glow after deactivation reminds that the STC/DSTC system has been reduced.



Parking assistance (option)

General¹

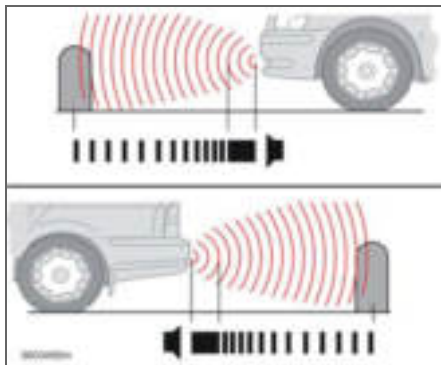

Parking assistance front and rear.

Parking assistance is used as an aid to parking. A signal indicates the distance to a detected object.

WARNING

Parking assistance does not relinquish the driver's own responsibility during parking. The sensors have blind spots where objects cannot be detected. Be aware of children or animals near the car

¹ Depending on the market, the **Parking assistance** system may be either standard, an option or an accessory.

Function

The system is activated automatically when the car is started and the text message **Park Assist active, Exit to deactivate** is shown on the audio system display.

Parking assistance is active at speeds below 15 km/h. The system is deactivated at higher speeds. When the speed is below 10 km/h the system is reactivated.

The frequency of the signal increases as you come closer to an object in front of or behind the car. If the volume of another audio source from the audio system is high, then this is automatically lowered.

The tone becomes constant at a distance of about 30 cm. If there are objects within this distance both behind and in front of the car, the signal alternates between left and right-hand speakers.

Rear parking assistance

The distance covered to the rear of the car is about 1.5 m. Rear parking assistance is activated when reverse gear is engaged. If the system is switched off, the audio system display shows the text **Park Assist deactivated Enter to activate** as soon as reverse gear is engaged. The signal comes from the rear loudspeakers.

The system must be deactivated when reversing with a trailer, or bike carrier on the towbar or similar. Otherwise the trailer or bike carrier would trigger the sensors.

Rear parking assistance is deactivated automatically when towing a trailer if a Volvo genuine trailer cable is used.

Front parking assistance

The distance covered to the front of the car is about 0.8 metres. The signal comes from the front loudspeakers.

Front parking assistance cannot be combined with auxiliary lamps because the sensors are affected by the auxiliary lamps.

Fault indicator



If the information symbol illuminates with constant glow and **PARK ASSIST SERVICE REQUIRED** is shown on the information display then parking assistance is disengaged.

WARNING

Some sources may deceive the system with false signals. Examples of such sources include horns, wet tyres on asphalt, pneumatic brakes and motorcycle exhaust pipes etc. Ice and snow covering the sensors may also cause false warning signals.



Parking assistance (option)

Activating/deactivating

Parking assistance can be deactivated by pressing **EXIT** on the control panel, see page 64. **Park Assist deactivated Enter to activate** will appear on the audio system display. Parking assistance can be reactivated by pressing **ENTER** on the control panel. The display then shows **Park Assist active Exit to deactivate**.

Cleaning the sensors

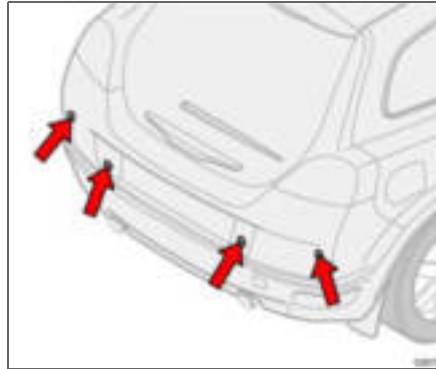

Parking assistance sensors.

The sensors must be cleaned regularly to ensure that they work properly. Clean them with water and car shampoo.



Blind Spot Information System BLIS (option)

General

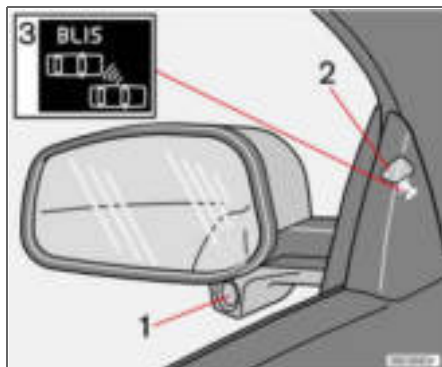

Rearview mirror with BLIS system.

1. BLIS camera
2. Indicator lamp
3. BLIS symbol

WARNING

The system is a supplement to, not a replacement for, a safe driving style and use of the rearview mirrors. It can never replace the driver's attention and responsibility. The responsibility for changing lanes safely always rests with the driver.

BLIS is an information system that under certain conditions can help to draw the driver's

attention to vehicles moving in the same direction in the so-called "blind spot".

The system is designed to work most effectively when driving in dense traffic on multi-lane highways.

BLIS is based on digital camera technology. The cameras (1) are located under the door mirrors.

When a camera has detected a vehicle inside the blind spot zone the indicator lamp (2) illuminates with a constant glow.

NOTE

The lamp illuminates on the side of the car where the system has detected the vehicle. If the car is overtaken on both sides at the same time then both lamps illuminate.

BLIS advises the driver with a message if a fault arises in the system. If for example the system's cameras are obscured then the BLIS indicator lamp flashes and a message is shown in the information display. In such cases, check and clean the lenses. If necessary, the system can be switched off temporarily by pressing the **BLIS** button, see page 127.

Blind spots

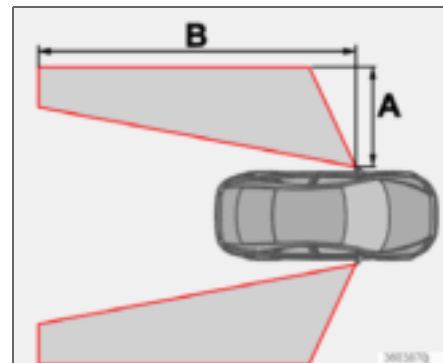

"Blind spots" intended to be covered by BLIS cameras.

Distance A = approx. 3.0 m

Distance B = approx. 9.5 m

Cleaning

In order to work most effectively the BLIS camera lenses must be clean. The lenses can be cleaned with a soft cloth or damp sponge.



Blind Spot Information System BLIS (option)

Clean the lenses carefully so that they are not scratched.

IMPORTANT

The lenses are electrically heated to melt ice or snow. If necessary, brush snow away from the lenses.

When BLIS operates

The system is active when the car is driven at a speed above 10 km/h.

Overtaking

The system is designed to react if you overtake at a speed of up to 10 km/h faster than the overtaken vehicle.

The system is designed to react if you are overtaken by a vehicle travelling up to 70 km/h faster than your vehicle.

WARNING

BLIS does not work in sharp bends.

BLIS does not work when the car is reversing.

A wide trailer coupled to the car can conceal other vehicles in adjacent lanes. It can prevent the vehicle in the screened area from being detected by BLIS.

Daylight and darkness

In daylight the system reacts to the shape of the surrounding vehicles. The system is designed to detect motor vehicles such as cars, trucks, buses and motorcycles.

In darkness the system reacts to the headlamps of surrounding vehicles. Vehicles with headlamps that are switched off are not detected by the system. This means for example that the system does not react to a trailer without headlamps which is towed behind a car or truck.

WARNING

The system does not react to bicycles or mopeds.

The BLIS cameras can be disrupted by intensive light or when driving in the dark when there are no light sources (e.g. street lighting or other vehicles). The system may then interpret the lack of light as if the cameras have been blocked.

In both cases a message is shown on the information display.

When driving in such conditions system performance may be temporarily reduced and a text message is shown, see page 127.

If the message disappears automatically then BLIS has returned to normal functionality.

The BLIS cameras have limitations similar to the human eye, i.e. they "see" worse in heavy snowfall or thick fog for example.



Blind Spot Information System BLIS (option)

Activating/deactivating



Button for activating/deactivating.

BLIS is activated when the engine is started. The indicator lamps in the door panels flash three times when BLIS is activated.

The system can be deactivated/activated by pressing **BLIS**.

When BLIS is deactivated the light in the button goes out and a text message is shown on the dashboard display.

When BLIS is activated the light in the button illuminates, a new text message is shown on the display and the indicator lamps in the door panels flash three times. Press the

READ button to clear the text message. For more information on messages, see page 43.

BLIS system message

| Text on the display | System status |
|--|--|
| BLIND SPOT SYST. SERVICE REQUIRED | Blind spot syst. disengaged. Contact an authorised Volvo workshop. |
| BLIS FUNCTION REDUCED | Reduced function. |
| BLIS CAMERA BLOCKED | One or both cameras blocked. Clean the lenses. |
| Blind spot syst. OFF | BLIS system off. |
| Blind spot syst. ON | BLIS system on. |



Towing and recovery

Never tow the car to bump start it

Use a donor battery if the battery is discharged and the engine does not start. Do not tow the car to bump start it.

! IMPORTANT

Bump starting the car can damage the catalytic converter.

Towing

Find out the highest legal speed for towing before towing the car.

- Turn the ignition switch to position **II** and unlock the steering lock so that the car can be steered, see page 112.
- The ignition key must remain in position **II** while the car is being towed.

Automatic gearbox

- Move the gear selector to position **N**.

Manual gearbox

- Move gear lever into neutral.
- Ensure the towrope is always taut to avoid violent jerks. Keep your foot on the brake pedal.

Cars with automatic gearbox must not be towed at speeds above 80 km/h or further

than 80 km. The car must always be towed facing forward.

! WARNING

The steering lock stays in the position it was in when the power was cut off. The steering lock must be unlocked before towing.

The ignition key must be in position **II**. Never remove the ignition key from the ignition switch while driving or when the car is being towed.

! WARNING

The brake servo and power steering do not work when the engine is switched off. The brake pedal must be pressed about five times harder than normal, and the steering will be considerably heavier than normal.

Recovery

If only partially raised, cars with automatic gearbox must not be transported at speeds above 80 km/h or further than 80 km. The car must always be towed with the wheels rolling forward.

Towing eye

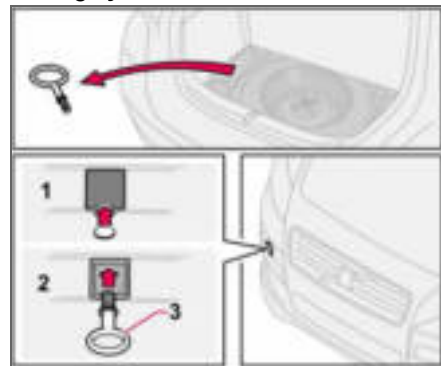

Use the towing eye if the car needs to be towed on the road. The towing eye is attached in the recess on the right-hand side of the front or rear bumper. To fit the towing eye:

1. Take out the towing eye that is located under the floor hatch in the cargo area.

**Towing and recovery**

2. Release the cover (1) on the bumper with a screwdriver or coin in the bottom edge.
3. Screw in the towing eye (3) firmly, right up to the flange. Use the wheel wrench to tighten the towing eye.
4. After use, unscrew the towing eye and return it in the cargo area. Refit the cover on the bumper.

**IMPORTANT**

The towing eye is only designed for towing on roads, not for pulling the car unstuck or out of a ditch. Call a recovery service for recovery assistance.



Jump starting

Starting with a donor battery

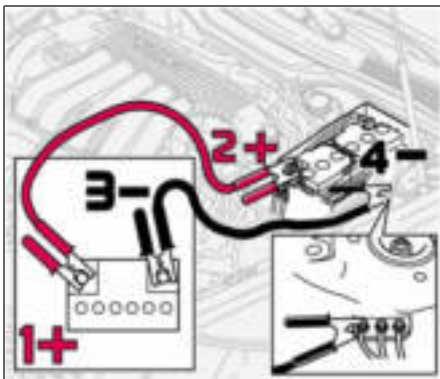

If the battery in the car has become flat, you can "borrow" electric current from either a separate battery or the battery in another car. Always make sure the crocodile clips on the jump leads are attached securely to eliminate sparks during the start attempt.

When jump starting the car, the following steps are recommended to avoid risk of explosion:

1. Turn the ignition key to position **0**.
2. Ensure that the donor battery is 12 volt.
3. If the donor battery is in another car, switch off the engine in the other car

and ensure that the cars do not touch one another.

4. Connect the red jump lead between the positive terminal on the donor battery (1+) and the positive terminal in your car (2+).
5. Connect one end of the black jump lead to the donor battery's negative terminal (3-).
6. Connect the other end of the black jump lead to the earthing point (4-) by the left-hand strut tower.
7. Start the engine of the "donor car". Let the engine run a few minutes at a speed slightly higher than idle (1500 rpm).
8. Start the engine of the car with the flat battery.
9. Remove the jump leads, first the black and then the red. Make sure that none of the clamps on the black jump lead comes into contact with the battery's positive terminal or the clamp connected to the red jump lead.



IMPORTANT

Do not touch the crocodile clips during the start procedure. There is a risk of sparks forming.



WARNING

The battery can generate oxyhydrogen gas, which is highly explosive. One spark, which can be generated if you connect the jump leads incorrectly, is sufficient to make the battery explode.

The battery contains sulphuric acid, which can cause serious burns. If the acid comes into contact with eyes, skin or clothing, flush with large quantities of water.

If acid splashes into the eyes, seek medical attention immediately.



Driving with a trailer

General

The load capacity is affected by extra accessories mounted on the car, such as a towbar, load carriers, space box, the passengers' combined weight etc. as well as the load on the towball. The load capacity of the car is reduced by the number of passengers and their weight.

If the towing bracket is fitted by an authorised Volvo workshop, then the car is delivered with the necessary equipment for driving with a trailer.

- The car's towing bracket must be of an approved type.
- If the towbar is retrofitted, check with your Volvo dealer that the car is fully equipped for driving with a trailer.
- Distribute the load on the trailer so that the weight on the towing bracket follows the specified maximum towball load.
- Increase the tyre pressure to the recommended pressure for a full load. Tyre pressure label location, see page 149.
- Clean the towbar regularly and grease the towball¹.

- Do not tow a heavy trailer when the car is brand new. Wait until it has been driven at least 1000 km.
- The brakes are loaded much more than usual on long and steep downhill slopes. Downshift to a lower gear and adjust your speed.
- The engine is loaded more heavily than usual when driving with a trailer.
- The engine and gearbox can overheat if the car is driven with a heavy load in hot weather. If the temperature gauge for the engine's cooling system goes into the red zone, stop and let the engine idle for a few minutes. The automatic gearbox responds through a built-in protection system. See the message on the information display. If the car overheats, the air conditioning may be switched off temporarily.
- In the interests of safety, speed should be restricted to 80 km/h, even if the laws of certain countries allow for higher speeds.
- Move the gear selector to park position **P** when parking an automatic car with a hitched trailer. Always use the parking brake. Block the wheels with chocks when parking a car with hitched trailer on a hill.

Trailer weights

Information on permitted trailer weights, see page 222.



WARNING

Follow the stated recommendations for trailer weights. Otherwise, the car and trailer may be difficult to control in the event of sudden movement and braking.



NOTE

The stated maximum permitted trailer weights are those permitted by Volvo. National vehicle regulations can further limit trailer weights and speeds. Towbars can be certified for higher towing weights than the car can actually tow.

¹ Does not apply to the towball if using a stabiliser hitch.



Driving with a trailer

Automatic gearbox, driving with a trailer

Parking on a hill

1. Apply the parking brake (handbrake).
2. Move the gear selector to park position **P**.

Starting on a hill

1. Move the gear selector to driving position **D**.
2. Release the parking brake (handbrake).

Steep inclines

- Select an appropriate manual gear position when climbing steep inclines or at low speeds. This prevents the gearbox from changing up and keeps the gearbox oil cooler.
- Do not use a higher manual gear than the engine can handle. It is not always economical to drive in high gears.
- Avoid driving with a trailer on inclines of more than 15 %.

Diesel 1.6D engine with manual gearbox, driving with a trailer

If the car is driven with a major load in a hot climate, the engine cooling fan can be replaced with one of a greater capacity than the standard model. Check with your nearest Volvo dealer regarding the options for your car.



Towing bracket

Towbars

The towball must be cleaned and greased regularly. When a towball hitch with vibration damper is used, the towball need not be greased.

If the car is equipped with a detachable towbar, the towball mounting instructions must be followed carefully, see page 135.

WARNING

Be sure to attach the trailer's safety cable to the correct place.

WARNING

If the car is fitted with a Volvo detachable towbar:

Follow the assembly instructions for the towball section carefully.

The towball section must be locked with the key before setting off.

Check that the indicator window shows green.

NOTE

Always detach the towball section after use. Keep it in the cargo area.

Trailer cable

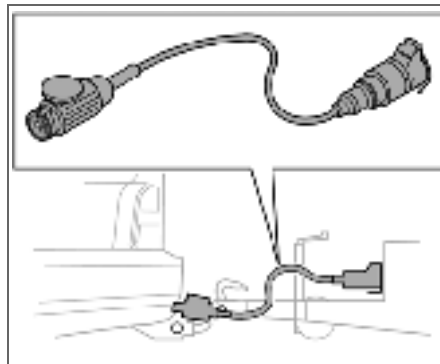

An adapter is required if the car's towing bracket has 13 pin electrics and the trailer has 7 pin electrics. Use an adapter cable approved by Volvo. Make sure the cable does not drag on the ground.



Towing bracket

Specifications

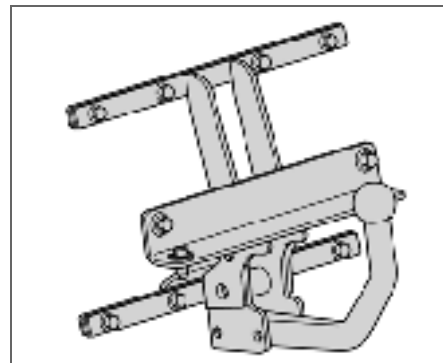
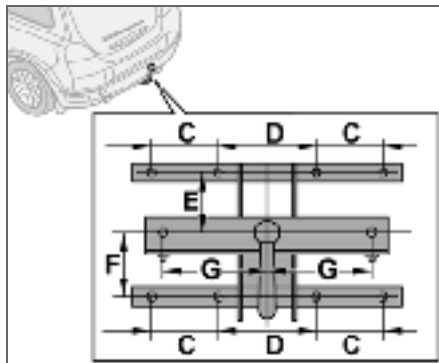
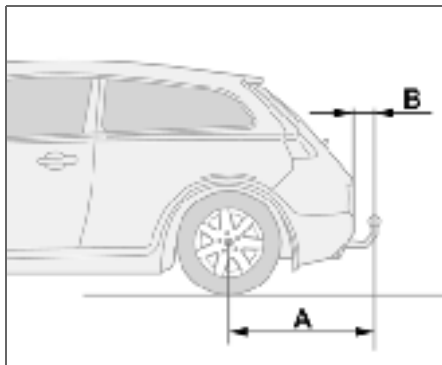

Dimensions for mounting points (mm)

| A | B | C | D | E | F | G |
|-----|----|-----|-----|-----|-----|-----|
| 852 | 98 | 100 | 140 | 130 | 113 | 150 |

06



Detachable towbar

Fitting the towball

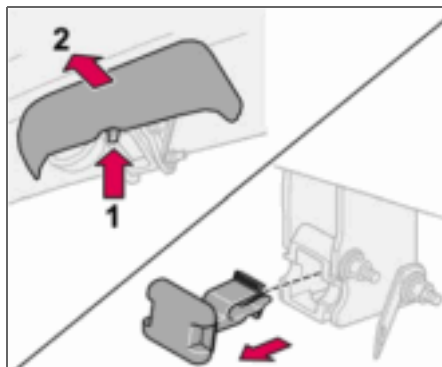

- Remove the guard plug.

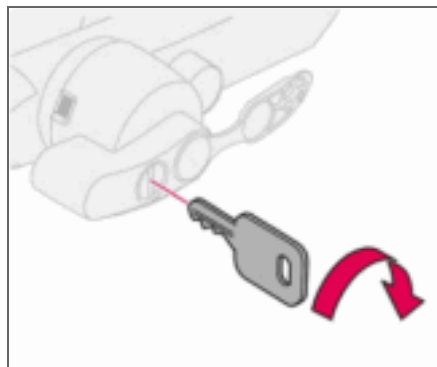

- Ensure that the mechanism is in the unlocked position by turning the key clockwise.

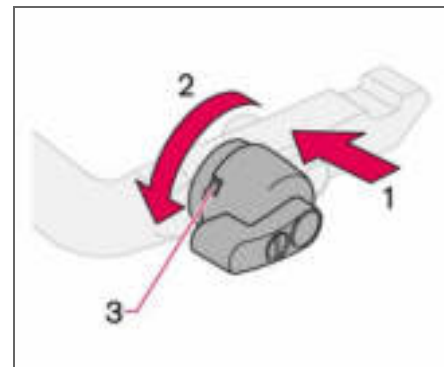

- Check that the indicator window (3) shows red. If the window does not show red, press in (1) and turn the locking wheel anticlockwise (2) until you hear a click.



Detachable towbar

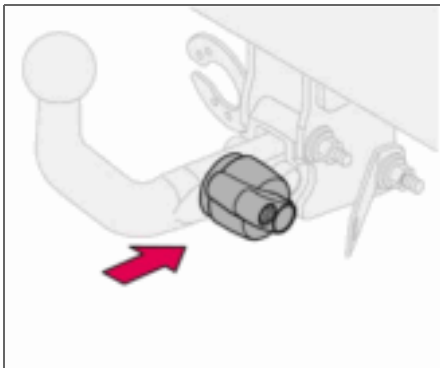

- Insert the towball section until you hear a click.

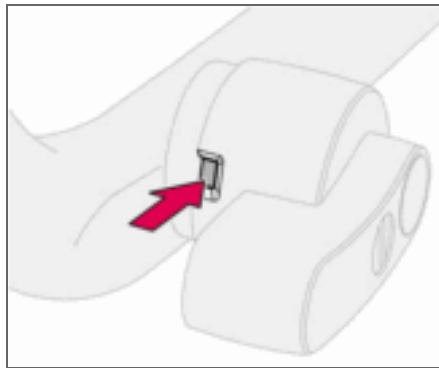

- Check that the indicator window shows green.

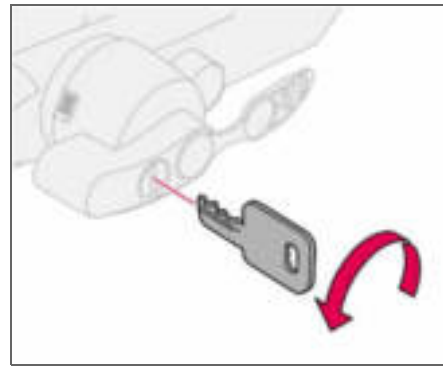

- Turn the key anticlockwise to locked position. Remove the key from the lock.

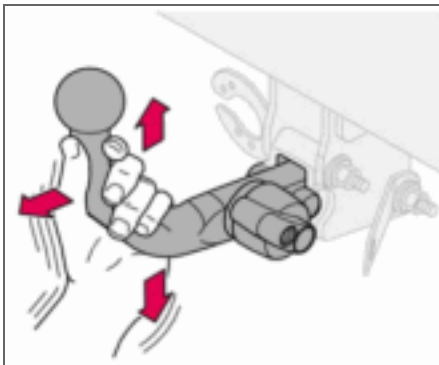

Detachable towbar

**i** NOTE

Check that the towball section is secure by pulling it up, down and back. If the towball section is not fitted correctly then it must be removed and refitted in accordance with the previous instruction.

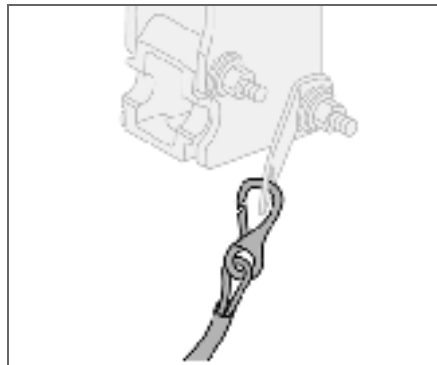
**i** NOTE

The trailer's safety cable must be attached to the bracket on the towbar.



Detachable towbar

Removing the towball

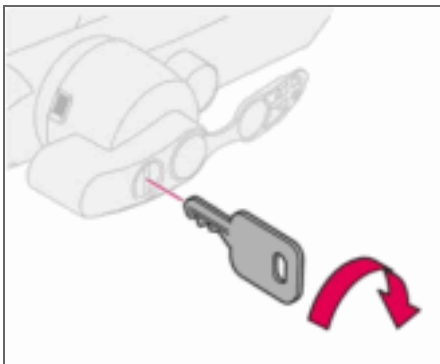

- Insert the key and turn it clockwise to the unlocked position.

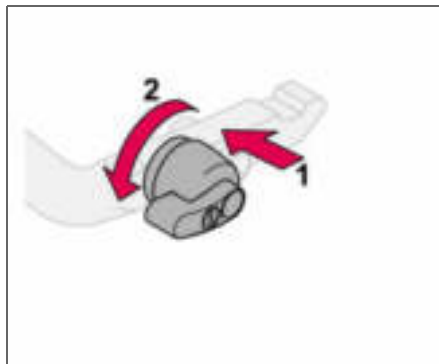

- Push in the locking wheel (1) and turn it anticlockwise (2) until you hear a click.

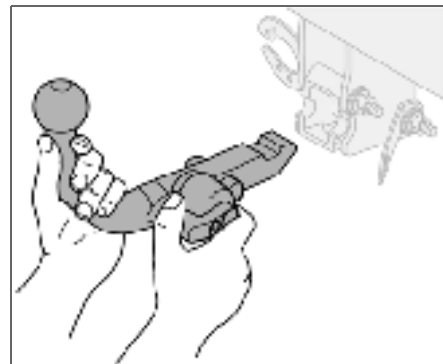

- Turn the locking wheel down fully, until it comes to a stop. Hold it in this position while pulling the towball rearward and upward.

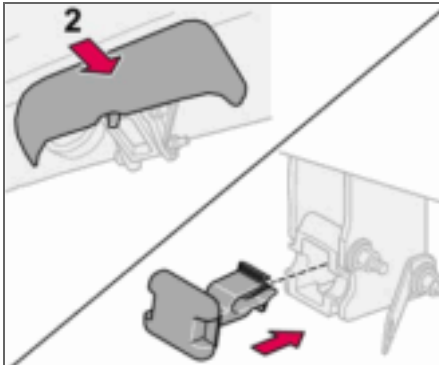
**Detachable towbar**

- Insert the guard plug.



Loading

General

The load capacity is affected by extra accessories mounted on the car, such as a towbar, the load on the towball, load carriers and space box, and the passengers' combined weight. The load capacity of the car is reduced by the number of passengers and their weight. For information on permitted weights, see page 222.

WARNING

The car's driving characteristics change depending on how heavily it is loaded and how the load is distributed.

Loading the cargo area

Stop the engine and apply the parking brake when loading or unloading long objects. The gear lever or gear selector can be knocked out of position by long loads, which could set the car in motion.

To increase the size of the cargo area, the head restraints can be removed and the seats folded down, see page 86.

Place the load firmly against the backrest in front.

- The head restraints can be removed so that they are not damaged.

- Put wide loads in the centre.
- Heavy objects should be placed as low as possible. Avoid placing heavy loads on a lowered backrest.
- Cover sharp edges with something soft to avoid damaging the upholstery or the large glass surface of the tailgate.
- Secure all loads to the load retaining eyelets with straps or web lashings.

WARNING

A loose object weighing 20 kg can, in a frontal collision at a speed of 50 km/h, carry the impact of an item weighing 1000 kg.

WARNING

Never load cargo above the backrest.

The protection provided by the inflatable curtain in the headlining may be compromised or eliminated if the load is too high.

Always secure the load. During heavy braking the load may otherwise shift, causing injury to the car's occupants.

Using load carriers

To avoid damaging the car and for maximum possible safety while driving, it is recommended to use load carriers specially designed for your car by Volvo.

Carefully follow the mounting instructions supplied with the load carriers.

- Check periodically that the load carriers and load are properly secured. Lash the load securely with retaining straps.
- Distribute the load evenly over the load carriers. Put the heaviest objects at the bottom.
- The size of the area exposed to the wind, and therefore fuel consumption, increase with the size of the load.
- Drive gently. Avoid quick acceleration, heavy braking and hard cornering.

WARNING

The car's centre of gravity and driving characteristics are altered by roof loads.



Adjusting headlamp pattern

Correct light pattern for left or right-hand traffic

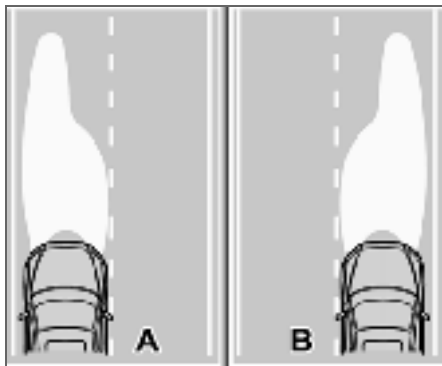

A. Headlamp pattern for left-hand traffic.
B. Right-hand traffic.

The headlamps' projection can be adjusted to avoid dazzling oncoming traffic. The correct pattern will also better illuminate the verge.

Halogen headlamps

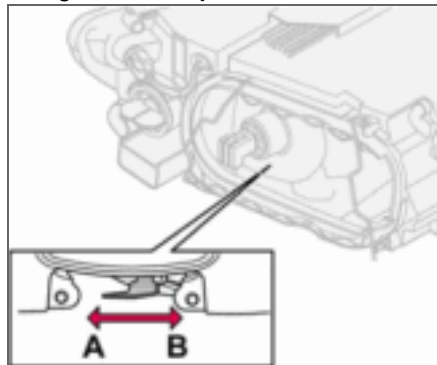

The headlamp control should be in position (A) for left-hand traffic and position (B) for right-hand traffic.

Bi-Xenon headlamps

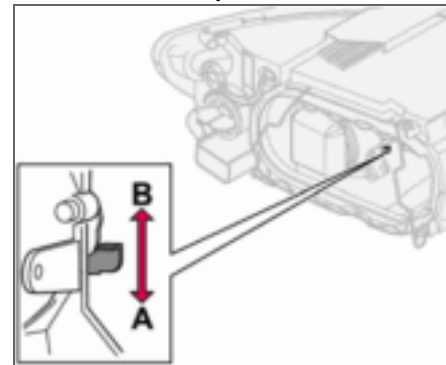

The headlamp control should be in position (A) for left-hand traffic and position (B) for right-hand traffic.

WARNING

On cars with Bi-Xenon headlamps, their replacement must be carried out by an authorised Volvo workshop. The headlamps must be handled with extreme care due to the high-voltage unit in the Xenon lamp.

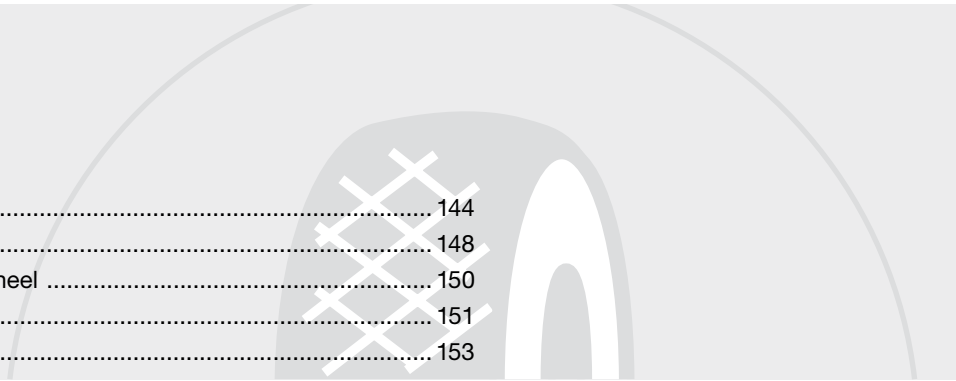

| | |
|--|-----|
| General | 144 |
| Tyre pressure | 148 |
| Warning triangle and spare wheel | 150 |
| Changing wheels | 151 |
| Emergency puncture repair | 153 |

WHEELS AND TYRES



07



07 Wheels and tyres

General

Driving characteristics and tyres

The tyres greatly affect the car's driving characteristics. The type of tyre, dimensions, tyre pressure and speed rating are important for how the car performs.

When changing tyres, ensure that tyres of the same type and dimensions, and preferably also the same make, are fitted to all four wheels. Follow the recommended tyre pressures specified on the tyre pressure label, for location see page 148.

Designation of dimensions

The dimensions are stated on all car tyres. Example of designation: 205/55R16 91 W.

| | |
|-----|--|
| 205 | Section width (mm) |
| 55 | Ratio between section height and width (%) |
| R | Radial ply |
| 16 | Rim diameter in inches (") |
| 91 | Tyre load index (in this case 615 kg) |
| W | Speed rating (in this case 270 km/h). |

Speed ratings

The car is approved as a whole, which means that dimensions and speed ratings must not differ from those specified on the vehicle registration document. The only exception to these conditions is winter tyres (both those with metal studs and those without). If such a tyre is chosen, the car must not be driven faster than the speed rating of the tyre (for example, class Q can be driven at a maximum of 160 km/h).

Remember that traffic regulations determine how fast a car can be driven, not the speed rating of the tyres.

Note! Maximum permitted speeds indicated.

| | |
|---|--------------------------------------|
| Q | 160 km/h (used only on winter tyres) |
| T | 190 km/h |
| H | 210 km/h |
| V | 240 km/h |
| W | 270 km/h |
| Y | 300 km/h |

New tyres

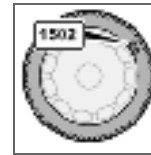

Tyres are perishable. After a few years they begin to harden at the same time as the friction capacity/characteristics gradually deteriorate. For this reason, aim to get as fresh tyres as possible when you replace them. This is especially important with regard to winter tyres.

The week and year of manufacture, the tyre's DOT marking (Department of Transportation), are stated with four digits, for example 1502. The tyre in the illustration was manufactured in week 15 of 2002.

Tyre age

All tyres older than six years should be checked by an expert even if they seem undamaged. The reason for this is that tyres age and decompose, even if they are hardly ever or never used. The function can therefore be affected due to the tyre's constituent materials being broken down. The tyre should then not be used. This also applies to spare tyres, winter tyres and tyres saved for future use. Examples of external signs which indicate that the tyre is unsuitable for use are cracks or discoloration.

The age of the tyre can be determined by the DOT marking, see illustration above.



More even wear and maintenance



The correct tyre pressure results in more even wear, see page 149. To achieve the best traction and more even wear on the tyres, the regular switching of the front and rear tyres with each other is recommended. The first change should be after 5000 km and then at intervals of 10000 km, this is to avoid differences in tread depth. Tyres with the greatest tread depth should always be fitted to the rear wheels to decrease the risk of skidding. Contact an authorised Volvo workshop if you are uncertain about tread depth.

Wheels should be stored lying down or hanging up, and not standing up.

Tyres with tread wear indicators

Tread wear indicators are narrow treadless bands across the width of the tread. On the side of the tyre are the letters TWI (Tread Wear Indicator). When the tyre's tread depth is down to 1.6 mm, the tread depth will be level in height with the tread wear indicators. Change to new tyres as soon as possible. Remember that tyres with little tread depth provide very poor grip in rain and snow.

Winter tyres

Volvo recommends winter tyres with specific winter tyre dimensions. These are stated on the tyre pressure label, for location see page 148. The tyre dimensions are dependent on the engine variant. When driving on winter tyres, they must be fitted to all four wheels.

i NOTE

Ask a Volvo dealer which rim and tyre types are most suitable.

Studded tyres

Studded winter tyres should be run in gently for 500–1000 km so the studs settle properly into the tyres. This gives the tyre, and especially the studs, a longer service life.

i NOTE

The legal provisions for the use of studded tyres vary from country to country.

Tread depth

Road conditions with ice, slush and low temperatures place considerably higher demands on tyres than summer conditions. It is therefore recommended not to drive on winter tyres that have a tread depth of less than four millimetres.

Snow chains

Snow chains may only be used on the front wheels, also applies to all-wheel drive cars.

Never drive faster than 50 km/h with snow chains. Avoid driving on bare ground as this wears out both the snow chains and tyres. Never use quick-fit snow chains as the space between the brake disks and the wheels is too small.

i IMPORTANT

Use Volvo genuine snow chains or equivalent chains designed for the car model, and tyre and rim dimensions. Consult an authorised Volvo workshop

General

Rims and wheel nuts

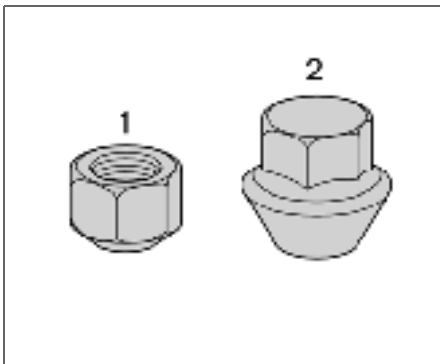

Standard (1) and bulge acorn (2) wheel nuts

Only use rims that are tested and approved by Volvo and which are included in the Volvo genuine accessories range. There are two types of wheel nut, depending on whether the rims are made of steel or aluminium. Tighten the wheel nuts to 90 Nm. Check the torque with a torque wrench.

! IMPORTANT

The wheel nuts should be tightened to 90 Nm. Overtightening can damage the nuts and the bolts.

Steel rims – standard wheel nuts (1)

Steel rims are normally mounted with the standard wheel nuts, but the bulge acorn variety may also be used.

! WARNING

Never use standard nuts for aluminium rims. The wheel could come loose.

Aluminium rims – bulge acorn wheel nuts (2)

Only use the bulge acorn variety of nuts with aluminium rims. These differ markedly from other nut types as they have a rotating conical washer.

i NOTE

These nuts may also be used with steel rims.

Locking wheel nuts

Locking wheel nuts can be used on both aluminium and steel rims. If steel rims with locking wheel nuts are used in combination with wheel covers, the locking wheel nut should be mounted on the bolt nearest the air valve. Otherwise the wheel cover cannot be fitted to the rim.

Spare wheel Temporary Spare

The spare wheel¹ is only intended to be used for the short time it takes to get the ordinary wheel replaced or repaired. Replace the spare wheel with a normal wheel as soon as possible. The car's handling may be altered by the use of the spare wheel.

Never drive faster than 80 km/h with a spare wheel on the car.

! IMPORTANT

The car must never be driven fitted with more than one "Temporary Spare" wheel.

¹ Certain variants and markets.



Summer and winter wheels

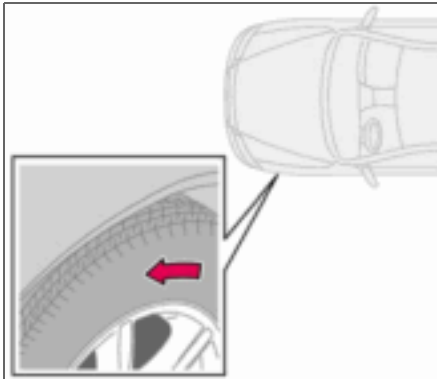

The arrow shows the tyre's direction of rotation

When summer and winter wheels are changed the wheels should be marked with which side of the car they were mounted on, for example **L** for left and **R** for right. Tyres with a tread pattern which are designed to only turn in one direction have the direction of rotation marked with an arrow. The tyre must always rotate in the same direction throughout its lifespan. Tyres should only be switched between front and rear positions, never between left and right-hand sides, or vice versa. If the tyre is mounted incorrectly, the car's braking characteristics and capacity to force rain, snow and slush out of the

way are adversely affected. Tyres with the greatest tread depth should always be fitted to the rear of the car (to decrease the risk of skidding).

Wheels should be stored lying down or hanging up, and not standing up.

Contact an authorised Volvo workshop if you are uncertain about tread depth.

Tyre pressure

Recommended tyre pressure

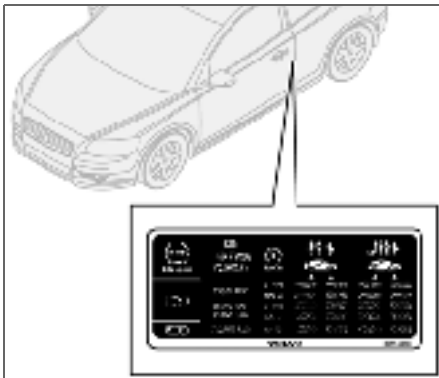

The tyre pressure label on the driver's side door pillar shows which pressures the tyres should have at different loads and speed conditions.

NOTE

Full load in the car equates to the number of seats with seatbelts.

Stated on the decal:

- Tyre pressure for the car's recommended wheel dimension
- ECO pressure

- Spare wheel pressure (Temporary Spare).

Checking the tyre pressure

Check the tyre pressure regularly.

NOTE

Tyre pressure decreases over time, this is a natural phenomenon. Tyre pressure also varies depending on ambient temperature.

Even after several kilometres of driving, the tyres warm up and the pressure increases. So air must not be released if the pressure is checked when the tyres are warm. While the pressure must be increased if it is too low. Inadequately inflated tyres adversely affect fuel consumption, tyre lifespan and the car's roadholding. Driving on tyres with tyre pressure that is too low can also result in the tyres overheating and disintegrating.

For information on the correct tyre pressure, refer to the tyre pressure table on page 149. ("Cold tyres" means the tyres are the same temperature as the ambient temperature.)

Fuel economy, ECO pressure

At speeds under 160 km/h, the general tyre pressure for full load is recommended in order to obtain optimum fuel economy.

Tyre pressure affects travelling comfort, road noise and steering characteristics.



| |
|----------------------|
| Tyre pressure |
|----------------------|

Tyre pressure table

| Variant | Tyre size | Speed (km/h) | Load, 1-3 persons | | Max. load | |
|--------------------------|-------------------------------------|---------------------------|-------------------|------------------|------------------|------------------|
| | | | Front (kPa) | Rear (kPa) | Front (kPa) | Rear (kPa) |
| 1.6 | 195/65 R15 91V | 0-160 | 230 | 210 | 250 | 250 |
| 1.8 | 205/55 R16 91V/W | 160+ | 250 | 210 | 280 | 260 |
| 1.8F | 195/65 R15 91Q/T/H/V M+S | | | | | |
| 2.0 | 205/55 R16 91Q/T/H/V M+S | | | | | |
| 1.6D | 205/50 R17 93W Extra Load | 0-160 | 240 | 220 | 250 | 250 |
| | 215/45 R18 93W Extra Load | 160+ | 260 | 220 | 280 | 260 |
| | 205/50 R17 93Q/T/H/V M+S Extra Load | | | | | |
| 2.4 | 205/55 R16 91V/W | 0-160 | 230 | 210 | 250 | 250 |
| 2.4i | 205/55 R16 91Q/T/H/V M+S | 160+ | 250 | 210 | 280 | 260 |
| 2.0D | | 205/50 R17 93W Extra Load | 0-160 | 240 | 220 | 250 |
| | 215/45 R18 93W Extra Load | 160+ | 260 | 220 | 280 | 260 |
| | 205/50 R17 93Q/T/H/V M+S Extra Load | | | | | |
| | | | | | | |
| T5 | 205/55 R16 91 V/W | 0-160 | 230 | 210 | 250 | 250 |
| D5 | 205/55 R16 91Q/T/H/V M+S | 160+ | 260 | 210 | 280 | 260 |
| | | 205/50 R17 93W Extra Load | 0-160 | 240 | 220 | 250 |
| | 215/45 R18 93W Extra Load | 160+ | 270 | 220 | 280 | 260 |
| | 205/50 R17 93Q/T/H/V M+S Extra Load | | | | | |
| All | All | 0-160 | 250 ¹ | 250 ¹ | 250 ¹ | 250 ¹ |
| Spare wheel ² | T125/85R16 99M | 0-80 | 420 | 420 | 420 | 420 |

¹ECO pressure, see page 148

²Temporary Spare

Warning triangle and spare wheel

Warning triangle

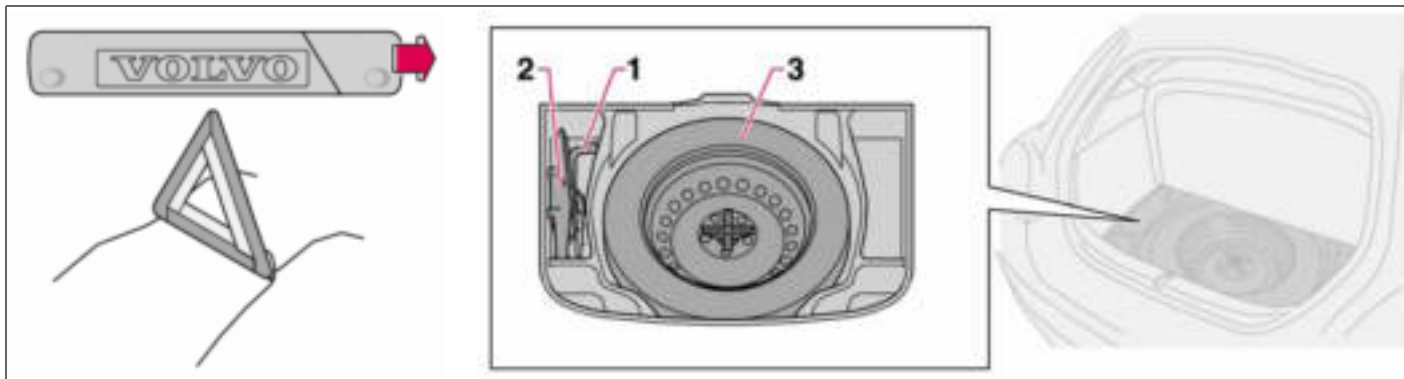

Follow the regulations for the use of a warning triangle¹. Position the warning triangle in a suitable place with regard to traffic.

1. Undo the case containing the warning triangle, it is secured with Velcro straps. Take the warning triangle from the case.
2. Lower the warning triangle's support legs.

Ensure the warning triangle and its case are properly secured in the cargo area after use.

¹ Certain markets.

Spare wheel and jack

The car's original jack

The original jack² must only be used for changing wheels. The jack's thread should always be well greased. The spare wheel, jack and wheel wrench are found under the floor in the cargo area.

Taking out the spare wheel:

A bolt runs through to secure the spare wheel.

² Certain variants and markets.

- Fold up the cargo area floor.
- Unscrew the retaining bolt and lift out the wheel.

Putting the spare wheel and jack into the cargo area:

- Wheel wrench.
- Jack and handle, secured with a tensioning strap.
- The spare wheel is bolted down with the rim side down using the through-bolt.



Changing wheels

Removing wheels

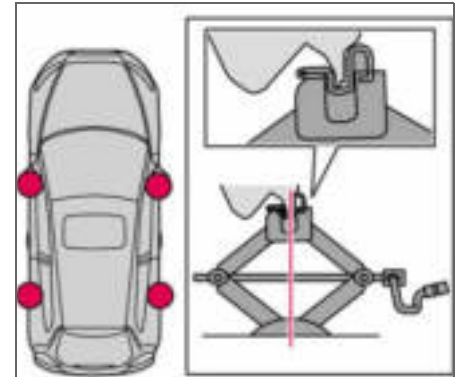
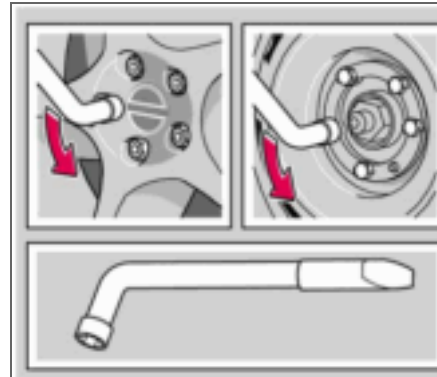
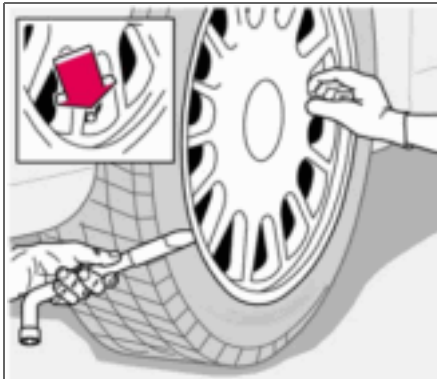

Set up the warning triangle if a wheel must be changed at a busy location. Make sure that the car and jack are on a firm horizontal surface.

- Take out the spare wheel, jack and wheel wrench that are located under the carpet in the cargo area.
 - Apply the parking brake and engage first gear, or position **P** if the car has an automatic gearbox.
 - Place chocks in front of and behind the wheels which will remain on the ground. Use heavy wooden blocks or large stones.
- Cars with steel rims have removable wheel covers. Prise off the wheel cover with the end of the wheel wrench, or pull it off by hand.
 - Loosen the wheel nuts $\frac{1}{2}$ -1 turn anticlockwise with the wheel wrench.
- There are two jacking points on each side of the car. Crank the foot of the jack down so it is pressed squarely on the ground. Check that the jack sits in the anchorage as illustrated and that the foot is positioned vertically under the anchorage.
 - Lift the car so that the wheel is free. Remove the wheel nuts and lift off the wheel.



Changing wheels

Fitting the wheel

- Clean the contact surfaces on the wheel and hub.
- Put on the wheel. Tighten the wheel nuts.
- Lower the car so that the wheels cannot rotate.
- Tighten the wheel nuts crosswise. It is important that the wheel nuts are tightened properly. Tighten to 90 Nm. Check the torque with a torque wrench.
- Put on the wheel cover (steel rim).



WARNING

Never crawl under the car when it is raised on the jack.

Passengers must leave the car when it is raised on the jack.

Ensure that passengers wait with the car - or preferably a crash barrier - between them and the road.



Emergency puncture repair

General

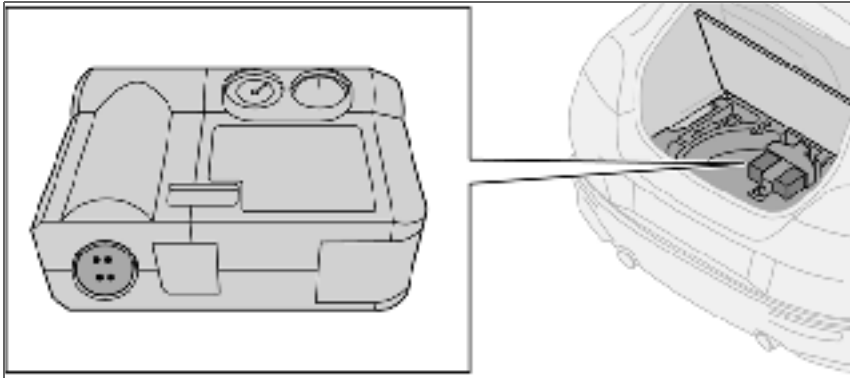

Cars which do not have a spare wheel are instead equipped with an emergency puncture repair kit. The emergency puncture repair kit can be used to both seal the puncture and to check and adjust the tyre pressure. The emergency puncture repair kit consists of an electric air compressor and an integrated canister with sealing liquid.

i NOTE

The jack is an option on cars equipped with emergency puncture repair kit.

Emergency puncture repair kit

The emergency puncture repair kit¹ is only intended to work as a temporary repair so that the car can be driven a further 200 km (max.) or to the nearest tyre centre. The sealing fluid has the capacity to effectively seal tyres which have punctures in the tread.

The sealing fluid canister should be replaced before its expiration date or after use of the puncture repair kit.

¹ Certain variants and markets.

The expiration date is located on the front of the compressor, see the illustration on page 158.

See page 158 for information on canister replacement.

i NOTE

The emergency puncture repair kit is only intended for sealing tyres with a puncture in the tread.



Emergency puncture repair

The emergency puncture repair kit has limited capacity to seal tyres which have punctures in the wall. Do not seal tyres with the emergency puncture repair kit if they have larger slits, cracks, irregularities or similar damage.

The emergency puncture repair kit with compressor and tools are located under the floor in the cargo area.

12 V sockets for the compressor are located by the centre console and the rear seat.



WARNING

The sealing fluid may cause irritation if it comes into direct contact with skin. In the case of contact with skin, wash away the fluid with soap and water.

Taking out the emergency puncture repair kit

- Fold away the rear edge of the floor mat, forward from the back.
- Lift up the emergency puncture repair kit.



Emergency puncture repair

Inflating tyres

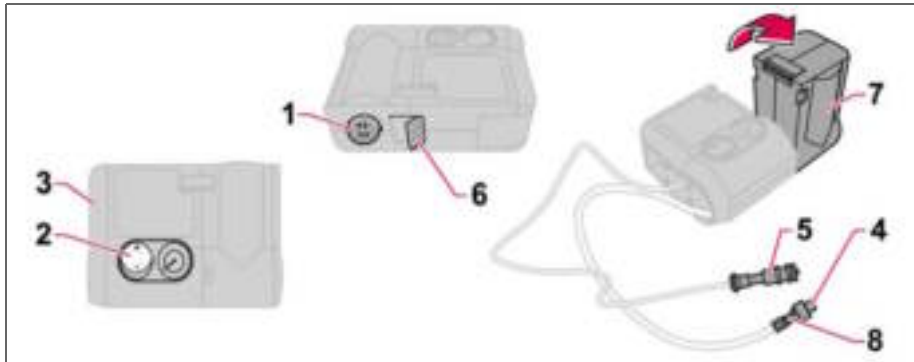

Set up the warning triangle if a tyre must be inflated in an area close to traffic.

- Ensure that the orange switch (2) is in position **0** and take out the lead (5) and air hose (4) from the side compartment (3).
- Screw the air hose's valve connection to the bottom of the thread on the tyre's air valve.
- Connect the lead (5) to one of the car's 12 V sockets.
- Start the engine. The car must be in a well-ventilated place.
- Start the compressor by flicking the switch (2) to position **I**.
- Pump up the tyre to the pressure specified on the tyre pressure label.
- Switch off the compressor, the switch (2) should be in position **0**. Detach the air hose and unplug the lead. Refit the dust cap.
- Put the lead (5) and air hose (4) into the side compartment (3).
- Put the puncture repair kit back under the floor in the cargo area.
- The compressor must not run for more than ten minutes. Let it cool afterwards as there is a risk of overheating.
- Objects with a volume up to 50 litres can be inflated with the compressor.



WARNING

Inhaling car exhaust fumes can result in danger to life. Never leave the engine running in sealed areas or areas that lack sufficient ventilation.

Emergency puncture repair

Sealing punctured tyres

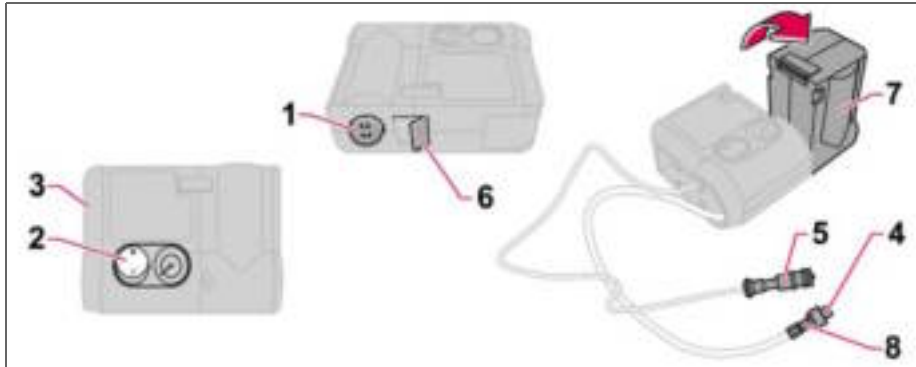

Set up the warning triangle if emergency tyre repairs must be carried out in an area where there is other traffic.

- Remove the decal (1) regarding the highest permitted speed from the emergency puncture repair kit and stick it on the steering wheel where it can be clearly seen by the driver.
- Ensure that the orange switch (2) is in position **0** and take out the lead (5) and air hose (4) from the side compartment (3).
- Screw the air hose's valve connection to the bottom of the thread on the tyre's air valve.

- Connect the lead (5) to the car's 12 V socket.
- Release the safety catch (6) and turn the orange-coloured part (7) 90 degrees to the vertical position, until a click is heard.
- Start the engine. The car must be in a well-ventilated place.

WARNING

Inhaling car exhaust fumes can result in danger to life. Never leave the engine running in sealed areas or areas that lack sufficient ventilation.

- Start the compressor by flicking the switch (2) to position **I**. There will be a temporary pressure increase of max. 4 bar while the sealing fluid is pumped in. After approx. one minute, the pressure will drop and the gauge will indicate the correct tyre pressure.
- Pump the tyre to a pressure of between 1.8 bar and 3.5 bar. If the pressure does not reach 1.8 bar after ten minutes of pumping, the compressor must be turned off so it does not overheat.



Emergency puncture repair

WARNING

Never stand next to the tyre when the compressor is running. Be particularly observant of the tyre walls. If cracks, irregularities or other damage appears, turn off the compressor immediately. Under these circumstances your journey should not continue. Contact an authorised tyre centre.

- Undo the air hose (4) from the tyre's air valve and refit the dust cap. Disconnect the lead (5) from the electrical socket. Fold the orange-coloured part (7) back into its original position and secure the catch (6). Keep the emergency repair kit in a safe place in the car.
- Immediately drive about 3 km, at a maximum speed of 80 km/h, to allow the sealing fluid to seal the tyre well.

WARNING

You should not drive faster than 80 km/h after the emergency tyre repair kit has been used. The temporarily sealed tyre must be changed as soon as possible (maximum driving distance: 200 km).

Check the tyre pressure again:

NOTE

Do not raise the orange-coloured part (7) when only the compressor is to be used for inflation.

- Connect the air hose (4) to the air valve on the tyre. Connect the lead (5) to the 12 V socket. Read the pressure on the compressor. If the tyre pressure is below 1.3 bar, the tyre has not been sufficiently well sealed. Under these circumstances your journey should not be continued. Contact a tyre centre.
- If the tyre pressure is higher than 1.3 bar, the tyre should be pumped up to the pressure stated on the tyre pressure label, for location see page 148. Relieve pressure with the reduction valve (8) if the tyre pressure is too high.
- Switch off the compressor, the switch (2) should be in position 0. Detach the air hose and unplug the lead. Refit the dust cap.
- Put the lead (5) and air hose (4) into the side compartment (3).
- Put the puncture repair kit back under the floor in the cargo area.

The compressor must not run for more than ten minutes. Let it cool afterwards as there is a risk of overheating.

NOTE

The canister with sealant and hose should be replaced after use.



Emergency puncture repair

Replacing the sealing fluid canister

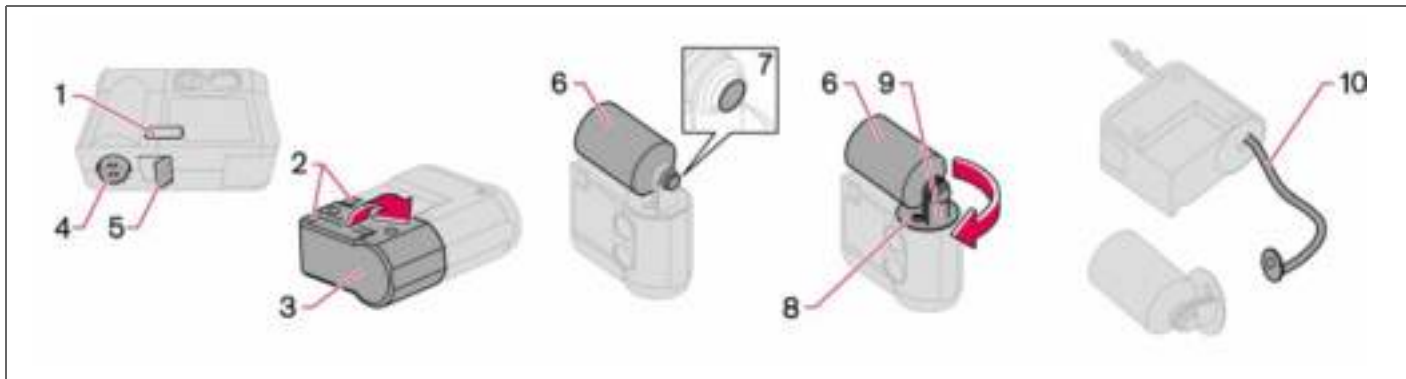

The sealing fluid canister should be replaced before its expiration date, see the date label (1), or after puncture repair. After use, the canister (6) with holder (8) and air hose (10) should be replaced.

This replacement can be carried out by an authorised Volvo workshop or by following the instructions.

! IMPORTANT

Read the safety instructions on the bottom of the canister.

! WARNING

Ensure the compressor is not connected to the 12 V socket when the canister is replaced.

Replacing the canister before the expiration date has been reached

- Undo the two screws (2) on the orange-coloured case (3).
- Remove the speed label (4) and date label (1), and open the safety catch (5). Loosen the case (3) and take it off.

- Unscrew and remove the canister (6).
- Check that the seal (7) on the new canister is not damaged. Screw in the canister.
- Refit the case (3). Check that the case is correctly fitted. Screw it on with the screws (2).
- Affix the speed label (4) and new date label (1) to the tyre repair kit.

Treat the removed canister as hazardous waste.

**Emergency puncture repair****Replacing the canister and hose after use**

- Undo the two screws (2) on the orange-coloured case (3).
- Remove the speed label (4) and date label (1), and open the safety catch (5). Loosen the case (3) and take it off.
- Push down the button (8) while turning the canister (6) and the holder (9) clockwise. Remove them.
- Pull out the air hose (10).
- Wipe off remaining sealing fluid with a rag or scrape it away if it has already dried.
- Fit a new air hose (10). Check that it is fitted correctly.
- Check that the seal (7) on the new canister is not damaged. Screw the holder (9) onto the canister (6) and turn it anticlockwise until a click is heard.
- Refit the case (3). Check that the case is correctly fitted. Screw it on with the screws (2).
- Affix the speed label (4) and new date label (1) to the tyre repair kit.

The empty canister and air hose can be treated as normal waste.



| | |
|-----------------------------|-----|
| Cleaning | 162 |
| Touching up paintwork | 165 |
| Rustproofing | 166 |

CAR CARE



08





Cleaning

Washing the car

Wash the car as soon as it becomes dirty. Use car shampoo. Dirt and road salt can lead to corrosion.

- Do not park the car in direct sunlight. Washing a car with hot paintwork can cause permanent paintwork damage. Wash the car in a car wash with waste water separator.
- Thoroughly rinse dirt off the underbody of the car.
- Rinse the entire car to remove loose dirt. When using a pressure washer: Make sure that the nozzle of the pressure washer is not closer than 30 cm to the bodywork. Do not spray directly onto the locks.
- Wash using a sponge, car shampoo and plenty of lukewarm water.
- If the dirt is difficult to dislodge, wash the car using a cold degreasing agent.
- Dry the car using a clean, soft chamois or a water scraper.
- Clean the wiper blades with a lukewarm soap solution or car shampoo.

Removing bird droppings

Wash away bird droppings from the paintwork as soon as possible. Bird droppings contain chemicals that affect and discolour

paintwork very quickly. This discoloration can only be removed by a specialist.

WARNING

Always have the engine cleaned by a workshop. There is a risk of fire if the engine is hot.

NOTE

Outside lighting such as headlamps, fog lamps and rear lamps may temporarily have condensation on the inside of the lens. This is a natural phenomenon, all outside lighting is designed to withstand this. Condensation is normally vented out of the lamp when it has been switched on for a time.

Automatic car washes

An automatic car wash is a simple and quick way of washing the car, but it can never replace a proper handwashing. The brushes of an automatic car wash cannot reach everywhere.

WARNING

Always test the brakes after washing, so that moisture and corrosion do not affect the brake linings and impair the brakes.

IMPORTANT

Washing by hand is gentler to the paintwork than an automatic car wash. Paintwork is also more sensitive when it is new. For this reason, handwashing is recommended during the first few months with a new car.

Lightly depress the brake pedal now and then when driving long distances in rain or slush. This heats and dries the brake pads. Do the same thing after starting in very damp or cold weather.

Exterior plastic parts

A special cleaning agent, available from Volvo dealers, is recommended for cleaning exterior plastic parts. Never use strong stain removers.

**Cleaning****Polishing and waxing**

Polish and wax the car if the paintwork is dull or to give the paintwork extra protection.

The car does not need to be polished until it is at least one year old. However, the car can be waxed before this time. Do not polish or wax the car in direct sunlight.

Wash and dry the car thoroughly before you begin polishing or waxing. Clean off asphalt and tar stains using Volvo tar remover or white spirit. More stubborn marks can be removed using fine rubbing paste designed for car paintwork.

Polish first with a polish and then wax with liquid or solid wax. Follow the instructions on the packaging carefully. Many preparations contain both polish and wax.

! IMPORTANT

Paint treatment such as preserving, sealing, protection, lustre sealing or similar could damage the paintwork. Paintwork damage caused by such treatment is not covered by Volvo warranty.

Cleaning door mirrors and front side windows with water-repellent surface (option)

Never use products such as car wax, degreaser or similar on mirror/glass surfaces as this could ruin their water-repellent properties.

Take care when cleaning so as not to damage the glass surface.

To avoid damaging glass surfaces when removing ice – only use plastic ice scrapers.

There is natural wear of the water-repellent coating.

Treatment with a special finishing agent available from Volvo dealers is recommended in order to maintain the water-repellent properties. This should be used first after three years and then each year.

Cleaning the interior**Treating stains on fabric upholstery**

A special cleaning agent, available from Volvo dealers, is recommended for cleaning the fabric upholstery. Other chemicals can impair the fire retardant qualities of the upholstery.

! IMPORTANT

Sharp objects and Velcro may damage the fabric upholstery.

Treating stains on leather upholstery

Volvo's leather upholstery is equipped with surface protection against dirt. Cleaning re-protects the leather but grease and dirt dissolves the surface protection. There is a comprehensive programme for the care and maintenance of leather upholstery. Volvo offers a leather product for cleaning and treating the upholstery by which means the leather regains its protective layer.

! IMPORTANT

Never use strong solvents. Such products may damage fabric, vinyl and leather upholstery.



Cleaning

IMPORTANT

Note that materials with colour that runs when dry (new jeans, suede garments etc.) may discolour the upholstery material.

To achieve best results Volvo recommends cleaning and application of the protective cream two to four times per year.

Ask your Volvo dealer about Volvo's Leather Care product

Washing instructions for leather upholstery

- Pour the leather cleaner on the dampened sponge and squeeze out a strong foam.
- Work the dirt away with gentle circular movements.
- Dab the sponge accurately on the stains. Allow the sponge to absorb the stain. Do not rub.
- Wipe off with soft paper or a cloth and allow the leather to dry completely.

Protective treatment of leather upholstery

- Pour a small amount of the protective cream on the felted cloth and massage in a thin layer of cream with gentle circular movements on the leather.
- Now allow the leather to dry for 20 minutes before use.

- The leather has now been given improved protection against stains and a UV filter.

Treating stains on interior plastic parts and surfaces

A special cleaning agent, available from Volvo dealers, is recommended for cleaning interior plastic parts and surfaces. Do not scrape or rub stains. Never use strong stain removers.

Cleaning seatbelts

Use water and a synthetic detergent. A special textile cleaning agent is available from your Volvo dealer. Make sure the seatbelt is dry before allowing it to retract.



Touching up paintwork

Paintwork

Paint is an important part of the car's rust-proofing and should therefore be checked regularly. To avoid the onset of rust, damaged paintwork should be rectified immediately. The most common types of paintwork damage are stone chips, scratches, and marks on the edges of wings and doors.

Colour code



Data plate

It is important that the correct colour is used. The colour code number (1) is shown on the data plate, see page 220.

Stone chips and scratches

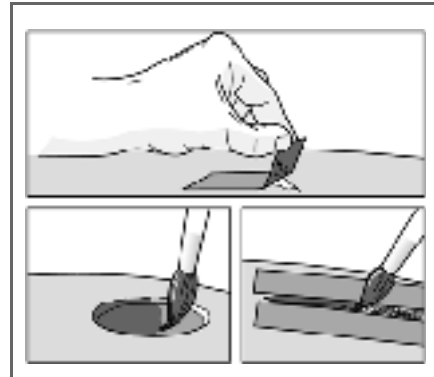

Before touching up paintwork, the car must be clean and dry and at a temperature above 15 °C.

Materials

- Primer in a can
- Paint in a can or touch-up pen
- Brush
- Masking tape

Minor stone chips and scratches

If the stone chip has not penetrated to the bare metal and there is an undamaged colour

coat, you can paint straight after cleaning the damaged area.

If the stone chip has penetrated to the bare metal

- Apply a piece of masking tape over the damaged surface. Then remove the tape to remove any loose paint.
- Stir the primer well and apply using a fine brush or a matchstick. Apply paint using a brush once the primer is dry.
- For scratches, proceed as above, but mask around the damaged area to protect the undamaged paintwork.
- After a few days, polish the touched-up areas. Use a soft rag and a small amount of lapping paste.



Rustproofing

Inspection and maintenance

Your car has already received a thorough and complete rustproofing at the factory. Parts of the body are made of galvanised sheet metal. The underbody is protected by a wear-resistant anti-corrosion compound. A thin, penetrating rustproofing fluid was sprayed into the members, cavities and closed sections.

Maintaining the car's rustproofing.

- Keep the car clean. Hose down the underbody. If using a pressure washer, keep the nozzle at least 30 cm from the painted surfaces.
- Regularly check and touch-up the rustproofing treatment as necessary.

The car's rustproofing does not normally require treatment for approximately 12 years. After this period, it should be treated at three-year intervals. If the car needs further treatment, please contact an authorised Volvo workshop.



| | |
|-------------------------------------|-----|
| Volvo service | 170 |
| Self-maintenance | 171 |
| Bonnet and engine compartment | 172 |
| Diesel | 173 |
| Oils and fluids | 174 |
| Wiper blades | 178 |
| Battery | 179 |
| Replacing bulbs | 181 |
| Fuses | 187 |

MAINTENANCE AND SERVICE

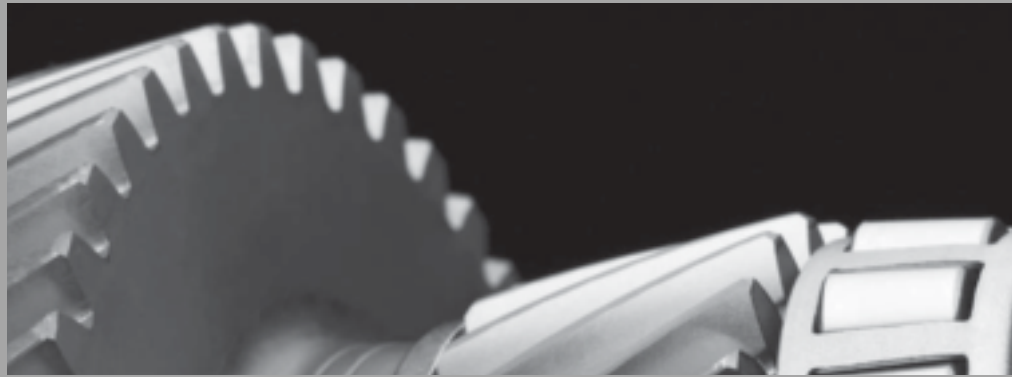

09



Volvo service

Volvo service programme

Before the car left the factory, it was thoroughly test driven. It was checked again in accordance with Volvo Car Corporation regulations before it was handed over to you.

To keep your Volvo as safe and reliable as possible, follow the Volvo service programme specified in the Service and Warranty Booklet. Have an authorised Volvo workshop carry out service and maintenance work. Volvo workshops have the personnel, special tools and service literature to guarantee the highest quality of service.



IMPORTANT

For the Volvo warranty to apply, check and follow the instructions in the Service and Warranty Booklet.

Special service measures

Certain service measures which affect the car's electrical system can only be performed using electronic equipment specially developed for your car. For this reason, always contact an authorised Volvo workshop before beginning or performing service work that affects the electrical system.

Installing accessories

The incorrect connection and installation of accessories can negatively affect the car's electrical system. Certain accessories only function when the appropriate software has been programmed into the car's electrical system. Always contact an authorised Volvo workshop before installing accessories which are connected to or affect the electrical system.

Recording vehicle data

One or more of the computers in your Volvo are capable of recording detailed information. This information is intended for use in research to enhance safety and for diagnosing faults in some of the in-car systems. The data may include details regarding seatbelt use by the driver and passengers, the functions of various vehicle systems and modules, and status information about the engine, throttle, steering, brakes and other systems. This data can also include details of the way the car is driven. This type of information can include, without being limited to, specific details such as vehicle speed, the use of the brake and accelerator pedals and steering wheel position. This latter type of data can be stored for a limited period while the car is being driven and subsequently during a collision or a near-collision. Volvo Car

Corporation will not disclose the stored information without consent. However, Volvo Car Corporation may be forced to disclose the information due to national legislation. Volvo Car Corporation and authorised Volvo workshops may also read and use the information.

Adverse driving conditions

Check the oil level more frequently for long journeys:

- Towing a caravan or trailer
- In mountainous regions
- At high speeds
- In temperatures colder than $-30\text{ }^{\circ}\text{C}$ or hotter than $+40\text{ }^{\circ}\text{C}$.

Also check the oil level more often if the car is often driven short distances (less than 10 km) when temperatures are low (below $+5\text{ }^{\circ}\text{C}$).

This can produce abnormally high oil temperature or oil consumption.



Before starting work on the car

Battery

Check that the battery cables are correctly connected and tightened.

Never disconnect the battery when the engine is running (e.g. if replacing the battery).

Never use a quick charger to charge the battery. The battery cables must be disconnected when charging the battery.

The battery contains acid that is both corrosive and toxic. It is therefore important to handle the battery in an environmentally-suitable way. Let your Volvo dealer assist you.

WARNING

High output from the ignition system. The voltage in the ignition system is highly dangerous. The ignition must therefore always be switched off for work in the engine compartment.

Do not touch the spark plugs or ignition coils when the ignition is on or the engine is hot.

Check regularly

Check the following at regular intervals, for example, when refuelling:

- Coolant – The level must be between the **MIN** and **MAX** marks on the expansion tank.
- Engine oil – The level must be between the **MIN** and **MAX** marks.
- Power steering fluid – The level must be between the **MIN** and **MAX** marks.
- Washer fluid – The reservoir should be well filled. Use washer antifreeze at temperatures around freezing.
- Brake and clutch fluid – The level must be between the **MIN** and **MAX** marks.

WARNING

Bear in mind that the radiator fan may start automatically some time after the engine has been switched off.

Always have the engine cleaned by a workshop. There is a risk of fire if the engine is hot.



Bonnet and engine compartment

Opening the bonnet

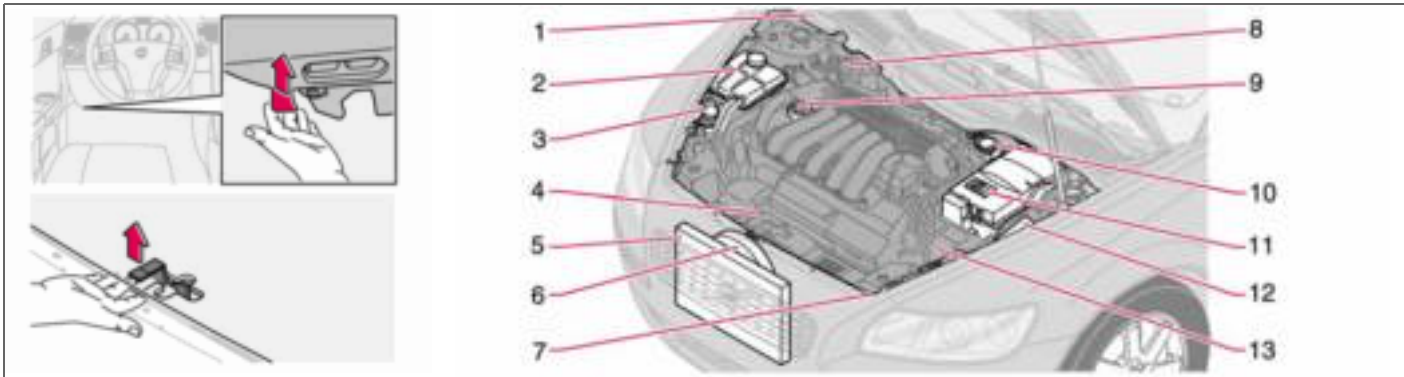

To open the bonnet:

- Pull the handle on the far left under the dashboard. You will hear when the catch releases.
- Insert your hand under the centre of the front edge of the bonnet and press the safety catch to the right.
- Open the bonnet.

WARNING

Check that the bonnet locks properly when closed.

Engine compartment

1. Washer fluid reservoir (4-cyl.) Illustration is slightly simplified
2. Coolant expansion tank
3. Reservoir for the power steering fluid (concealed behind the headlamp)
4. Engine oil dipstick¹
5. Radiator
6. Radiator fan
7. Washer fluid reservoir (5-cyl.)

8. Brake and clutch fluid reservoir (right-hand drive)
9. Filler opening for engine oil¹
10. Brake and clutch fluid reservoir (left-hand drive)
11. Battery
12. Relay and fuse box
13. Air filter¹

¹ Dependent on engine variant.



Fuel system

Diesel must fulfil the EN 590 or JIS K2204 standards. Diesel engines are sensitive to contaminants, such as high volumes of sulphur particles for example. Only use diesel fuel from a well-known producers. Never use diesel of dubious quality.

At low temperatures (−40 ℃ to −6 ℃), a paraffin precipitate may form in the diesel fuel, which can lead to ignition problems. The major oil companies produce a special winter-grade diesel for temperatures around freezing. This fuel is less viscous at low temperatures and reduces the risk of paraffin precipitate.

The risk of condensation in the fuel tank is reduced if the tank is kept well filled. When refuelling, check that the area around the fuel filler pipe is clean. Avoid spilling fuel onto the paintwork. Wash off any spillage with detergent and water.

IMPORTANT

Diesel type fuels which must not be used: special additives, Marine Diesel Fuel, fuel oil, RME (Rape Methyl Ester) and vegetable oil. These fuels do not fulfil the requirements in accordance with Volvo recommendations and generate increased wear and engine damage that is not covered by the Volvo warranty.

IMPORTANT

For model year 2006 or later the sulphur content must be a maximum of 50 ppm.

Empty tank

No special procedures are required if the tank runs dry. The fuel system is bled automatically if the ignition switch is kept in position **II** for approx. 60 seconds before the start attempt.

Draining condensation from the fuel filter

The fuel filter separates condensation from the fuel. Condensation can disrupt engine operation.

The fuel filter must be drained at the intervals specified in the Service and Warranty Booklet or if you suspect that the car has been filled with contaminated fuel.

IMPORTANT

Certain special additives remove the water separation in the fuel filter.



Oils and fluids

Engine compartment decal for oil grade



! IMPORTANT

Always use oil of the prescribed grade, see the engine compartment decal. Check the oil level frequently and change the oil regularly. The engine will be damaged if lower grade oil is used or if the car is driven with the oil level too low.

Using oil of a higher than specified grade is permitted. If the car is driven in adverse conditions, Volvo recommends using an oil of a higher grade than that specified on the decal. See page 226.

Checking the engine oil and oil filter

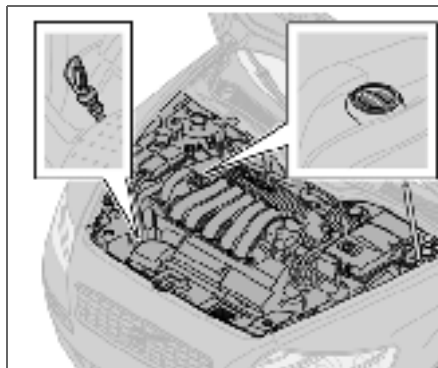

Dipstick, petrol engines

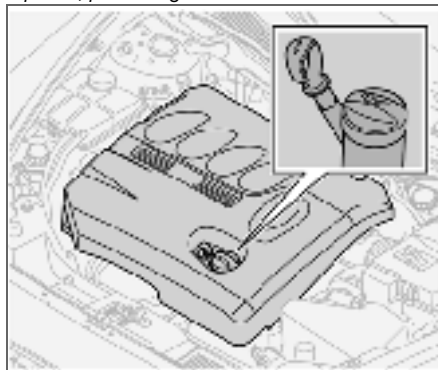

Dipstick, diesel engines

Volvo recommends  oil products. Change the oil and oil filter in accordance with the intervals specified in the Service and Warranty Booklet.

! IMPORTANT

In order to fulfil the requirements for the engine's service intervals all engines are filled with a specially adapted synthetic engine oil at the factory. The choice of oil has been made very carefully with regard to service life, starting characteristics, fuel consumption and environmental impact. An approved engine oil must be used in order that the recommended service intervals can be applied. Only use a prescribed grade of oil (see the engine compartment decal) for both filling and oil change, otherwise you will risk affecting service life, starting characteristics, fuel consumption and environmental impact. Volvo Car Corporation disclaims all warranty liability if engine oil of the prescribed grade and viscosity is not used.



Volvo uses different systems for warning of low oil level or low oil pressure. Certain variants have an oil pressure sensor, and then the lamp for oil pressure is used. Other variants have an oil level sensor, and then the driver is informed via the warning symbol in the centre of the instrument unit as well as by display texts. Certain models have both variants. Contact an authorised Volvo dealer for more information.

Checking the oil level in a new car is especially important before the first scheduled oil change. The Service and Warranty Booklet specifies the odometer readings for oil changes.

Volvo recommends checking the oil level every 2 500 km. The most accurate measurements are made on a cold engine before starting. The measurement will be inaccurate if taken immediately after the engine is switched off. The dipstick will indicate that the level is too low because the oil has not had time to flow down into the oil sump.

Checking the oil

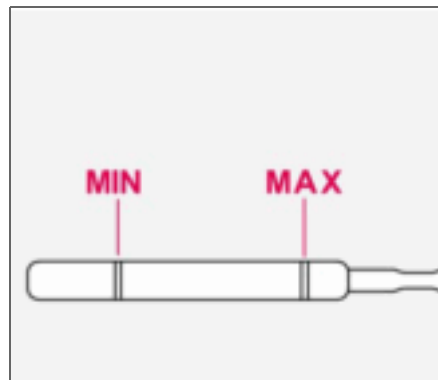

The oil level must be within the area marked on the dipstick.

Checking the oil in a cold engine:

- Wipe the dipstick clean before checking the level.
- Check the oil level using the dipstick. The level must be between the **MIN** and **MAX** marks.
- If the level is close to the **MIN** mark, start by topping up with 0.5 litres. Top up until the oil level is nearer the **MAX** than the **MIN** mark on the dipstick. See page 226–227 for capacities.

Checking the oil in a warm engine:

- Park the car on a level surface, switch off the engine and wait 10–15 minutes to allow the oil time to run back to the sump.
- Wipe the dipstick clean before checking the level.
- Check the oil level using the dipstick. The level must be between the **MIN** and **MAX** marks.

If the level is close to the **MIN** mark, start by topping up with 0.5 litres. Top up until the oil level is nearer the **MAX** than the **MIN** mark on the dipstick. See page 226–227 for capacities.



WARNING

Do not spill oil onto the hot exhaust manifold due to the risk of fire.



IMPORTANT

Never fill above the **MAX** mark. Oil consumption may increase if too much oil is poured into the engine.



Oils and fluids

Washer fluid, topping up

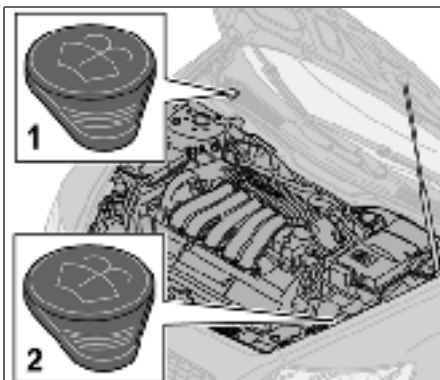

Location of washer fluid reservoir.

The windscreen and headlamp washers share a common reservoir.

- Filler cap on 4-cylinder engines and diesel.
- Filler cap on 5-cylinder engines.

Add washer antifreeze during the winter so that the fluid does not freeze in the pump, reservoir and hoses. For capacities, see page 231.

i NOTE

Mix the washer antifreeze and water before filling the reservoir.

Checking and topping up the coolant

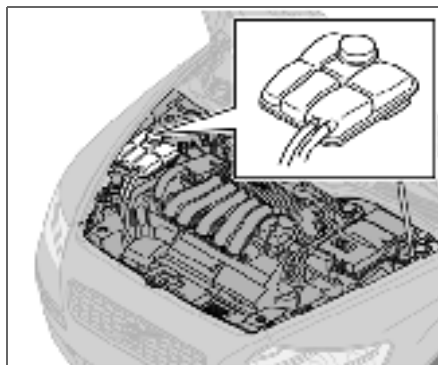

When topping up the coolant, follow the instructions on the packaging. It is important that the mixture of coolant concentrate and water is correct for the prevailing weather conditions. Never top up with water only. The risk of freezing increases with both too little and too much coolant concentrate.

! IMPORTANT

Always use coolant with anti-corrosion agent as recommended by Volvo. New cars are filled with coolant that can withstand temperatures down to approximately -35 °C.

For capacities, see page 230.

Check the coolant regularly

The level must lie between the **MIN** and **MAX** marks on the expansion tank. If the system is not filled sufficiently, high local temperatures could occur, causing a risk of damage (cracks) to the cylinder head. Top up the coolant when the level falls to the **MIN** mark.

! WARNING

Coolant can be very hot. If the coolant requires topping up when the engine is at operating temperature, unscrew the expansion tank cap slowly to gently release the overpressure.

i NOTE

The engine must only be run with a well-filled cooling system. High temperatures can occur, causing a risk of damage (cracks) to the cylinder head.



Checking and topping up the brake and clutch fluid

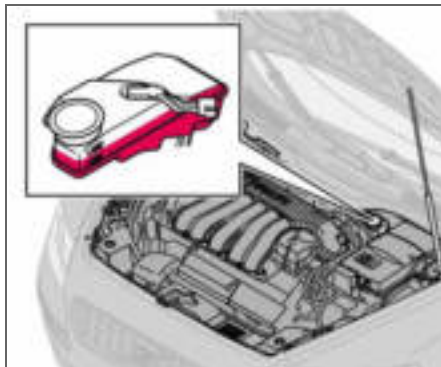

The brake and clutch fluid have a common reservoir¹. The fluid level must be between the **MIN** and **MAX** marks. Check the level regularly. Change the brake fluid every other year or at every other regular service.

See the capacities and recommended fluid grade on page 231.

The fluid should be changed annually on cars driven in conditions requiring hard, frequent braking, such as driving in mountains or tropical climates with high humidity.

¹ Location dependent on whether car is left or right-hand drive.

WARNING

If the brake fluid is under the **MIN** level in the brake fluid reservoir, do not drive further before topping up the brake fluid.

The reason for the loss of brake fluid must be investigated.

Checking and topping up the power steering fluid

NOTE

Check the level frequently.

The fluid does not require changing. For capacities and recommended fluid grade, see page 231.

If a fault should arise in the power steering system or if the car is without power and must be towed, it can still be steered. However, the steering will be much heavier than normal and it will require more effort to turn the steering wheel.



Wiper blades

Replacing the wiper blades

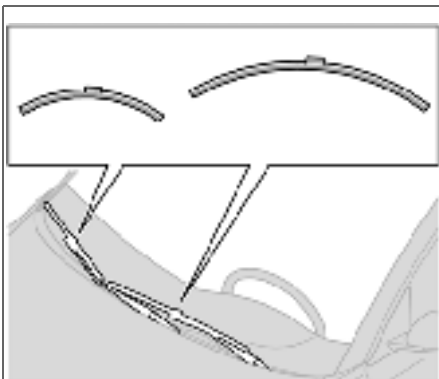

i NOTE

The wiper blades are different lengths. The blade on the driver's side is longer than on the other side.

- Turn up the wiper arm.
- Press the button located on the wiper blade mounting and pull straight out (1), parallel with the wiper arm.
- Slide in (2) the new wiper blade until a "click" is heard.
- Check (3) that the blade is firmly installed.
- Fold down the wiper arm.

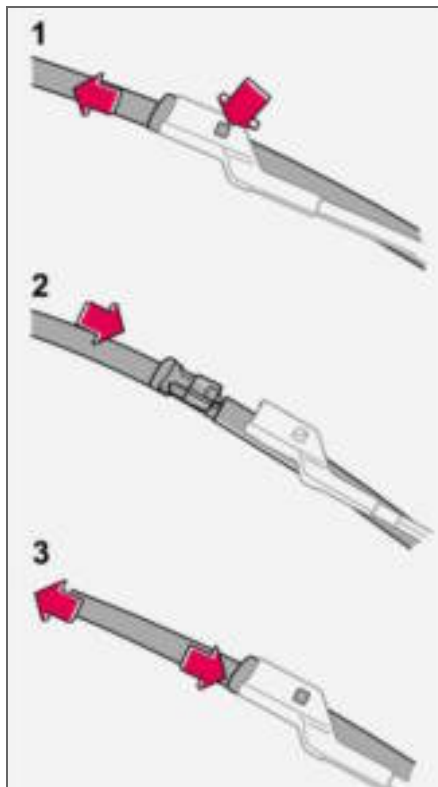

Replacing the wiper blades, rear window

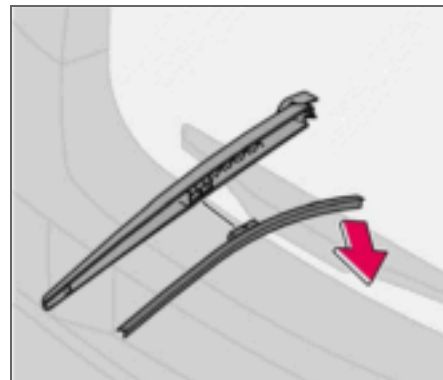

- Fold out the wiper arm.
- Detach the wiper blade by moving it straight out from the wiper arm.
- Press the new wiper blade into position. Check that it is firmly installed.
- Lower the wiper arm.



Battery care

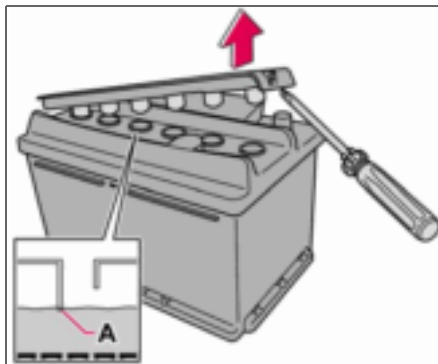

There may be two different types of battery. They are fully interchangeable with each other.

The service life and function of the battery is influenced by factors such as the number of starts, discharging, driving style, driving conditions and climatic conditions.

! IMPORTANT

Always use distilled or deionised water (battery water).

i NOTE

An expended battery must be recycled in an environmentally responsible manner as it contains lead.

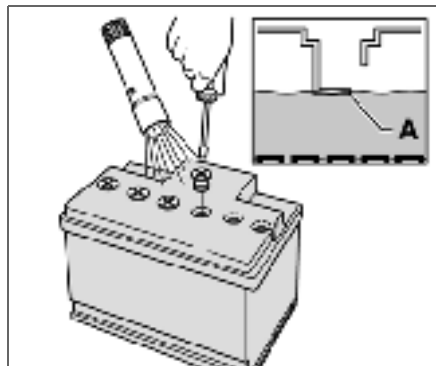

For the battery to function satisfactorily:

- Regularly check that the electrolyte level is correct (A) and never fill above the level mark.
- Check all of the cells. Use a screwdriver to remove the cell caps (or the cover).
- If necessary, top up with distilled water to the battery's maximum mark.
- Fit the cell caps (or the cover) firmly.

! WARNING

Batteries can generate oxyhydrogen gas, which is highly explosive. One spark, which can be generated if you connect the jump leads incorrectly, is sufficient to make the battery explode. The battery contains sulphuric acid, which can cause serious burns. If the acid comes into contact with eyes, skin or clothing, flush with large quantities of water. If acid splashes into the eyes, seek medical attention immediately.

i NOTE

The life of the battery is shortened if it becomes discharged repeatedly



Battery

Symbols on the battery



Use protective goggles.



Further information in the owner's manual.



Store the battery out of the reach of children.



The battery contains corrosive acid.



Avoid sparks and naked flames.



Risk of explosion.

Replacing the battery

Removing the battery

- Switch off the ignition and remove the key.
- Wait at least 5 minutes before touching any electrical terminals. This allows time for the information in the car's electrical system to be stored in the different control modules.
- Remove the cover.
- Disconnect the negative battery lead.
- Disconnect the positive battery lead.
- Undo the front wall of the battery box using a screwdriver.
- Release the clamp securing the battery.
- Remove the battery.

Fitting the battery

- Fit the battery into position.
- Fit the clamp securing the battery.
- Reinstall the front wall of the battery box.
- Connect the positive lead.
- Connect the negative lead.
- Refit the cover over the battery.



Replacing bulbs

General

All bulb specifications are given on page 236.

The following list contains bulbs and point-source lamps that are specialised or unsuitable for replacement except at a workshop:

- General interior lighting in the roof
- Reading lamps and glovebox lighting
- Indicator, door mirror and approach lighting
- High-level brake light
- Bi-Xenon headlamp

WARNING

On cars with Bi-Xenon headlamps the replacement must be carried out by an authorised Volvo workshop. The headlamps must be handled with extreme care due to the high-voltage unit in the Xenon lamp.

IMPORTANT

Never touch the glass part of the bulbs with your fingers. Grease and oil from your fingers are vaporised by the heat, coating the reflector and then causing damage.

Replacing front bulbs

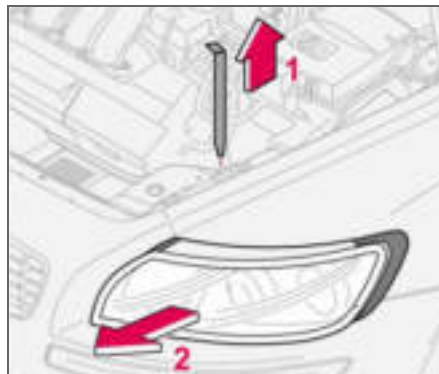

All front bulbs (except for fog lamps) are replaced by first removing the lamp housing from the engine compartment.

Removing the lamp housing:

- Remove the ignition key and turn the light switch to position 0.
- Withdraw the lamp housing's locking pin (1).
- Pull the lamp housing to the side and then forward (2).

IMPORTANT

Do not pull the electrical cable, only the connector.

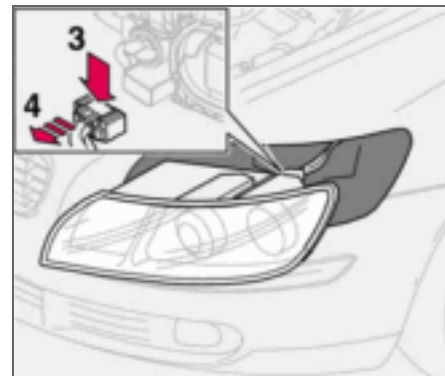

- Unplug the connector by pressing down the clip with a thumb (3) while moving out the connector (4) with the other hand.
- Lift out the lamp housing and place it on a soft surface to avoid scratching the lens.

Fitting the lamp housing:

- Plug in the connector and refit the lamp housing and locking pin. Check that the pin is correctly inserted.
- Check the lighting.

The lamp housing must be plugged in and secured in place before the lighting is turned on or the ignition key inserted into the ignition switch.



Replacing bulbs

Dipped beam

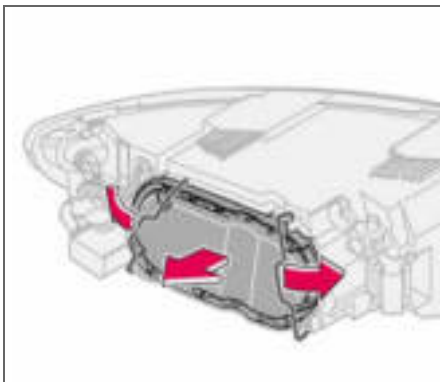

Removing the cover and bulb:

- Remove the entire lamp housing.
- Bend aside the catches and remove the cover.
- Unplug the connector from the bulb.
- Release the spring clip securing the bulb. First, press it to the left to release it, then out and down.
- Pull out the bulb.
- Refit the lamp housing.

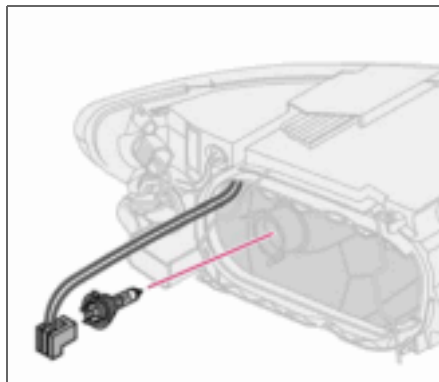

Fitting a new bulb

- Fit the new bulb. It can only fit in one position.
- Press the spring clip up and then slightly to the right so that it clicks into place.
- Press the connector back on.
- Refit the plastic cover.
- Refit the lamp housing.

Main beam

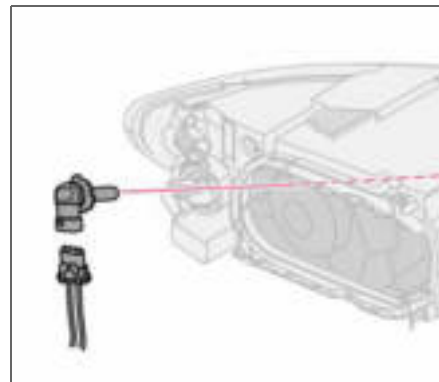

- Remove the entire lamp housing.
- Left-hand headlamp:
Turn the bulb holder anticlockwise.
- Right-hand headlamp:
Turn the bulb holder clockwise.
- Withdraw the bulb holder and replace the bulb.
- Refit the bulb holder. It can only be refitted in one position.
- Refit the lamp housing.



Replacing bulbs

09

Position/parking lamps

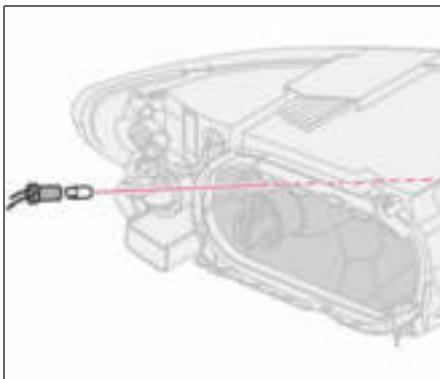

- Withdraw the bulb holder using pliers. Do not pull out the bulb holder by pulling the electrical cable.
- Replace the bulb.
- Press the bulb holder back on. It can only be refitted in one position.

Direction indicators

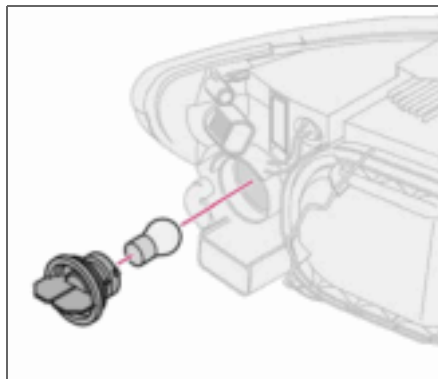

- Twist the bulb holder anticlockwise and remove it.
- To remove the bulb from the bulb holder, press the bulb in and turn it anticlockwise.
- Fit a new bulb and refit the bulb holder into the lamp housing.

Side marker lamps

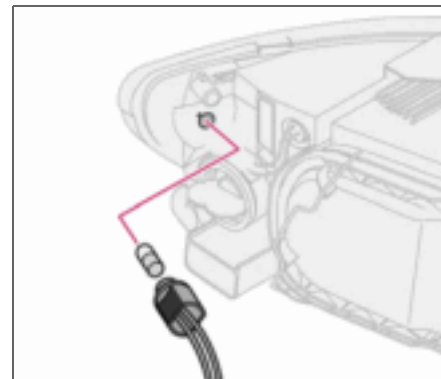

- Twist the bulb holder anticlockwise and withdraw it. Replace the bulb.
- Refit the bulb holder. It can only fit in one position.



Replacing bulbs

Fog lamps

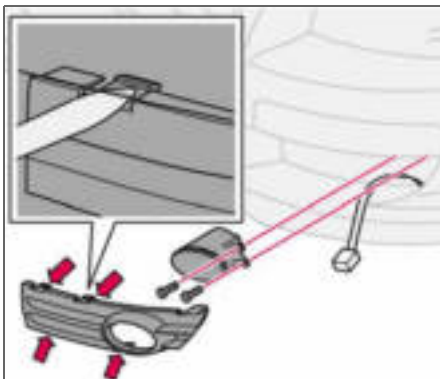

- Switch off all lights and turn the ignition key to position **0**.
- Remove the panel from around the lamp housing.
- Remove the two Torx screws securing the lamp housing and take out the lamp housing.
- Unplug the connector from the bulb.
- Turn the bulb anticlockwise and pull it out.
- Fit the new bulb and turn it clockwise.
- Plug in the connector to the bulb.
- Secure the lamp housing with the screws and press the panel back into place.

Removing the bulb holder

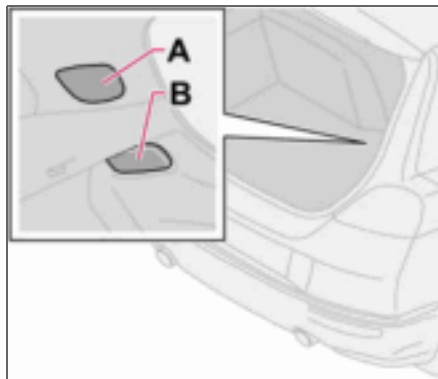

- All bulbs in the rear lamp cluster can be replaced from inside the cargo area. Switch off all lights and turn the ignition key to position **0**.
- Remove the covers (**A or B**) in the left/right-hand panel to access the bulbs. The bulbs are located in separate bulb holders.
- Unplug the connector from the bulb holder.
- Press the catches together and pull out the bulb holder.
- Replace the bulb and plug in the connector. Press the bulb holder into place and refit the cover (**A or B**).

Location of the bulbs in the rear lamp cluster

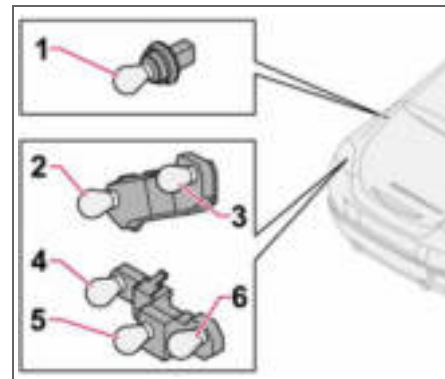

Bulb holder

i NOTE

If the error message **BULB FAILURE/ CHECK STOP LAMP** remains after a faulty bulb has been replaced then consult an authorised Volvo workshop.

1. Brake light
2. Position/parking and fog lamps
3. Position/parking lamps
4. Indicator
5. Reversing lamp
6. Position/parking lamps



Replacing bulbs

Number plate lighting

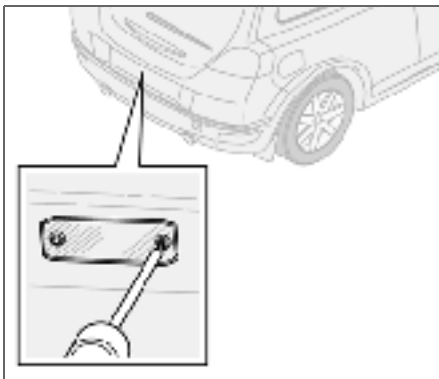

- Switch off all lights and turn the ignition key to position **0**.
- Remove the screws with a screwdriver.
- Detach the lens carefully.
- Replace the bulb.
- Refit and screw in the lens.

Reflector

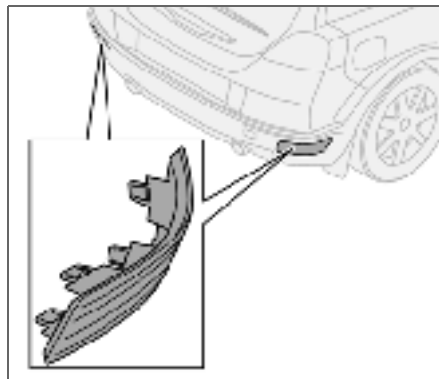

The reflector is secured with clips and is pressed in. It can only fit in one position.

Courtesy lighting

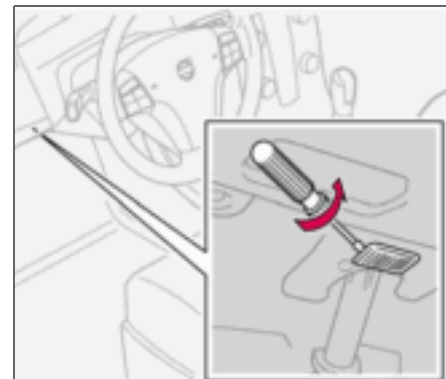

- There is courtesy lighting under the dashboard on the driver and passenger sides.
- Insert a screwdriver and gently turn so that the lens detaches.
- Remove the blown bulb.
- Fit a new bulb.
- Refit the lens.



Replacing bulbs

Cargo area

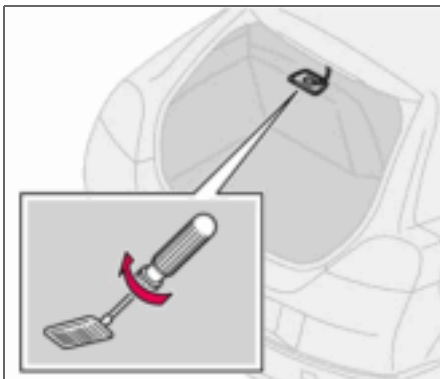

Insert a screwdriver and gently turn so that the lamp housing comes loose.

Interior lighting in cargo area

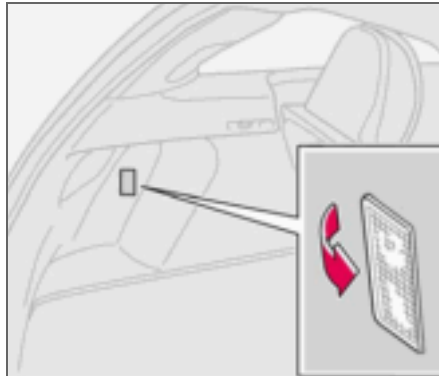

Cargo area lighting also includes a further lamp on the left-hand side of the cargo area.

- Insert a screwdriver and gently turn so that the lens detaches.
- Unplug the connector from the bulb holder.

Vanity mirror lighting

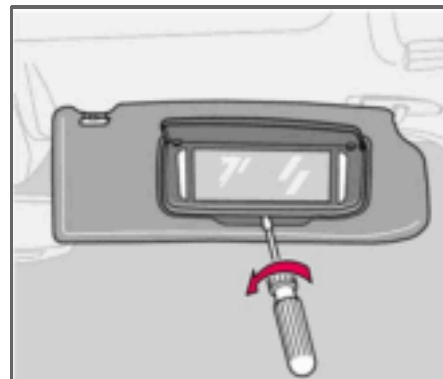

Removing the mirror glass:

- Insert a screwdriver underneath the lower edge, in the centre. Carefully prise up the lug on the edge.
- Insert the screwdriver underneath the edge on the left and right-hand sides (by the black rubber sections), and prise carefully so that the glass comes loose in the lower edge.
- Carefully detach and lift aside the entire mirror glass and cover.

Fitting the mirror glass:

- First, press the three lugs at top edge of mirror glass back into position, then press in the three lower ones.



General

All electrical functions and components are fused to protect the car's electrical system from damage by short circuiting and overloading.

The fuses are in two different locations in the car:

- Relay/fuse box in the engine compartment
- Relay/fuse box in the passenger compartment.

Replacement

If an electrical component or function does not work, it may be because the component's fuse was temporarily overloaded and blew.

- Look in the fuse diagram to locate the fuse.
- Pull out the fuse and check from the side to see whether the curved wire has blown.
- If this is the case, replace it with a new fuse of the same colour and amperage.

Each fuse box has space for several spare fuses. If the same fuse fails repeatedly then there is a fault in the component. In which case, contact an authorised Volvo workshop to have the system checked.



Fuses

Relay/fuse box in the engine compartment

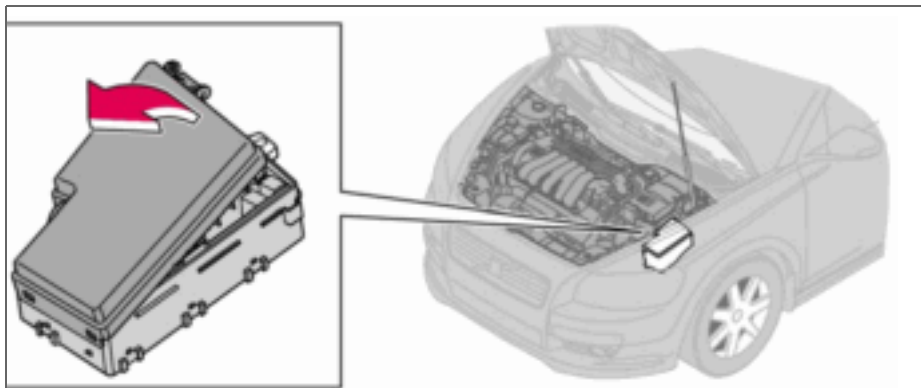

The fuse box has 36 fuse positions. Be sure to replace a blown fuse with a new fuse of the same colour and amperage.

- Fuses 19–36 are of the "Mini Fuse" type.
- Fuses 7–18 are of the "JCASE" type and should be replaced by an authorised Volvo workshop.
- Fuses 1–6 are of the "Midi Fuse" type and may only be replaced by an authorised Volvo workshop.

On the inside of the cover are tweezers to assist removing and fitting fuses.



Fuses

09

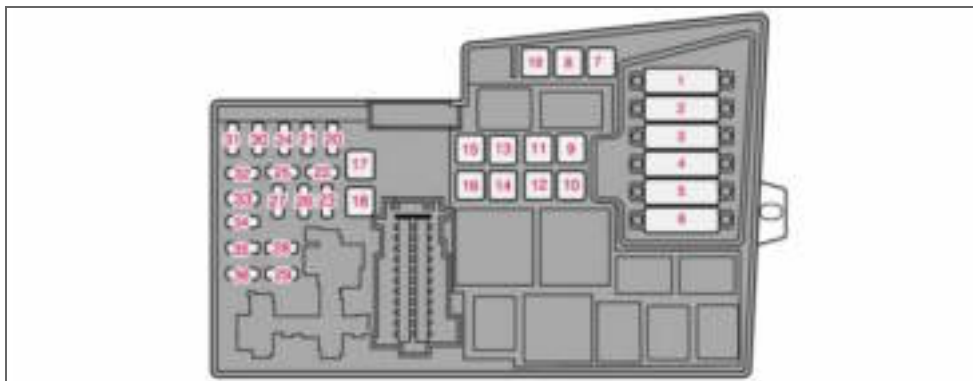

| | | | |
|--|------|---|------|
| 1. Radiator fan | 50 A | 13. Starter motor relay | 30 A |
| 2. Power steering (not 1.6 l engine) | 80 A | 14. Trailer wiring | 40 A |
| 3. Supply to passenger compartment fuse box | 60 A | 15. Reserve | - |
| 4. Supply to passenger compartment fuse box | 60 A | 16. Supply to infotainment system | 30 A |
| 5. Climate control element, additional heater PTC (option) | 80 A | 17. Windscreen wipers | 30 A |
| 6. Glow plugs (4-cyl. diesel) | 60 A | 18. Supply to passenger compartment fuse box | 40 A |
| Glow plugs (5-cyl. diesel) | 70 A | 19. Reserve | - |
| 7. ABS pump | 30 A | 20. Horn | 15 A |
| 8. ABS valves | 20 A | 21. Fuel-driven additional heater, passenger compartment heater | 20 A |
| 9. Engine functions | 30 A | 22. Reserve | - |
| 10. Ventilation fan | 40 A | 23. Engine control module ECM (5-cyl. petrol) transmission (TCM) | 10 A |
| 11. Headlamp washer | 20 A | | |
| 12. Supply to heated rear window | 30 A | | |



Fuses

| | |
|---|------|
| 24. Heated fuel filter, PTC element oil trap (5-cyl. diesel) | 20 A |
| 25. Reserve | - |
| 26. Ignition switch | 15 A |
| 27. A/C compressor | 10 A |
| 28. Reserve | - |
| 29. Front fog lamp | 15 A |
| 30. Engine control module ECM (1.6 l petrol, 2.0 l diesel) | 3 A |
| 31. Voltage regulator, alternator 4-cyl. | 10 A |
| 32. Injectors (5-cyl. petrol), lambda-sond (4-cyl. petrol), charge air cooler (4-cyl. diesel), mass air flow sensor and turbo control (5-cyl. diesel) | 10 A |
| 33. Lambda-sond and vacuum pump (5-cyl. petrol), engine control module (5-cyl. diesel), diesel filter heater (4-cyl. diesel) | 20 A |
| 34. Ignition coils (petrol), injectors (1.6 l petrol), fuel pump (4-cyl. diesel), pressure switch, climate control (5-cyl.), glow plugs and EGR emission control (5-cyl. diesel) | 10 A |
| 35. Engine sensors for valves, relay coil, air conditioning PTC element, oil trap (5-cyl. petrol), engine control module ECM (5-cyl. diesel), canister (petrol), injectors (1.8/2.0 l petrol, MAF mass air flow sensor (5-cyl. petrol, 4-cyl. diesel), turbo control (4-cyl. diesel), pressure switch power steering (1.6 l petrol), EGR emission control (4-cyl. diesel) | 15 A |
| 36. Engine control module ECM (not 5-cyl. diesel), accelerator pedal position sensor, lambda-sond (5-cyl. diesel) | 10 A |



Relay/fuse box in the passenger compartment

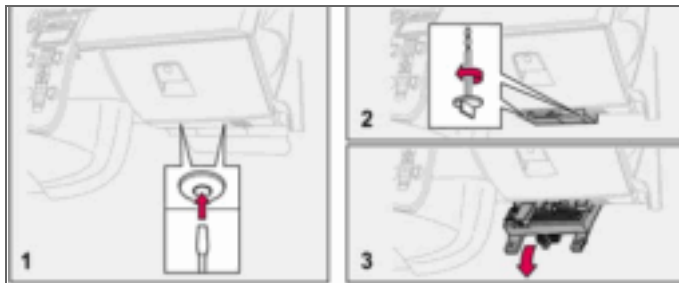

The fuse box has 50 fuse positions. The fuses are located under the glovebox. The box also provides space for several spare fuses. Tools for fuse replacement are located in the relay/fuse box in the engine compartment, see page 188.

Replacing fuses:

- Remove the interior trim concealing the fuse box by pressing in the pin in the centre of the clips (1) about one cm and then withdrawing the clips.
- Turn the two wing screws (that secure the fuse box) (2) anticlockwise so that they detach.
- Lower the fuse box (3) half way. Pull it towards the seat until it stops. Lower it completely. The fuse box can be fully unhooked.
- Close the fuse box in the reverse order.
- Remove the pins from the centre of the clips. Fit the trim and the clips. Reinsert the pins into the clips. This expands the clips and secures the trim.



Fuses

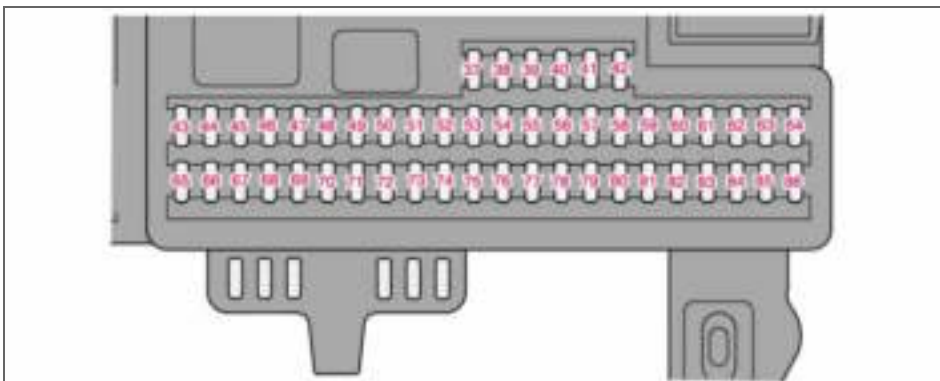

| | | | |
|--|------|--|-------|
| 37. Reserve | - | 50. Reserve | - |
| 38. Reserve | - | 51. Parking assistance, additional heater for the passenger compartment, Bi-Xenon (option) | 10 A |
| 39. Reserve | - | 52. Transmission control module (TCM), ABS system | 5 A |
| 40. Reserve | - | 53. Power steering | 10 A |
| 41. Reserve | - | 54. Engine control module ECM (5-cyl.) | 10 A |
| 42. Reserve | - | 55. Remote control module, Keyless control module | 20 A |
| 43. Phone, audio system, RTI (option) | 15 A | 56. Siren control module | 10 A |
| 44. SRS system | 10 A | 57. Data link connector (DLC), brake light switch | 15 A |
| 45. Electrical socket | 15 A | 58. Main beam right, auxiliary lamps relay coil | 7.5 A |
| 46. Passenger compartment, glovebox and courtesy lighting | 5 A | 59. Main beam, left | 7.5 A |
| 47. Interior lighting | 5 A | 60. Seat heating (driver's side) | 15 A |
| 48. Washer, rear window | 15 A | 61. Seat heating (passenger side) | 15 A |
| 49. SRS system | 10 A | | |



Fuses

| | | | |
|---|------|---|-----|
| 62. Sunroof | 20 A | 86. Interior lighting, cargo area lighting, power seats, fuel level display (1.8F) | 5 A |
| 63. Reserve | - | | |
| 64. Audio system, RTI (option) | 5 A | | |
| 65. Infotainment system | 5 A | | |
| 66. Infotainment control module (ICM), climate control | 10 A | | |
| 67. Reserve | - | | |
| 68. Cruise control | 5 A | | |
| 69. Climate control, rain sensor | 5 A | | |
| 70. Reserve | - | | |
| 71. Reserve | - | | |
| 72. Reserve | - | | |
| 73. Sunroof, overhead console (OHC) rear seatbelt reminder, autodim mirror | 5 A | | |
| 74. Fuel pump relay | 15 A | | |
| 75. Reserve | - | | |
| 76. Reserve | - | | |
| 77. Reserve | - | | |
| 78. Reserve | - | | |
| 79. Reversing lamp | 5 A | | |
| 80. Reserve | - | | |
| 81. Reserve | - | | |
| 82. Supply to front right door | 25 A | | |
| 83. Supply to front left door | 25 A | | |
| 84. Power passenger seat | 25 A | | |
| 85. Power driver's seat | 25 A | | |

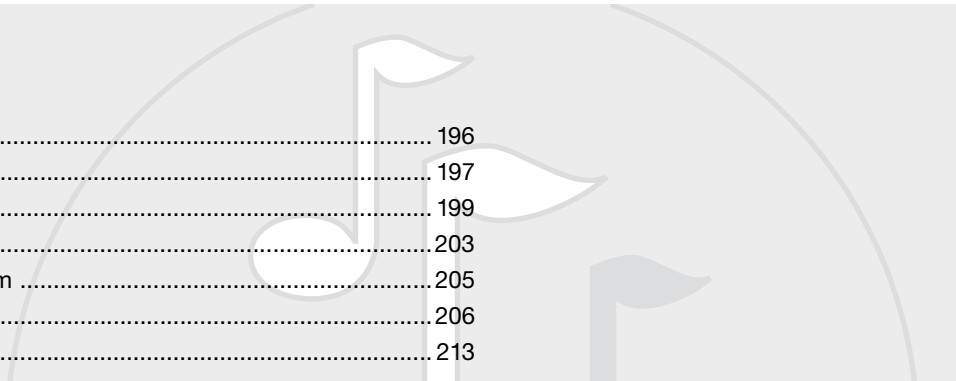

| | |
|-------------------------------------|-----|
| General | 196 |
| Audio functions | 197 |
| Radio functions | 199 |
| CD functions | 203 |
| Menu structure – audio system | 205 |
| Phone functions (option) | 206 |
| Menu structure – phone | 213 |

INFOTAINMENT SYSTEM



10



10 Infotainment system

General

Infotainment system

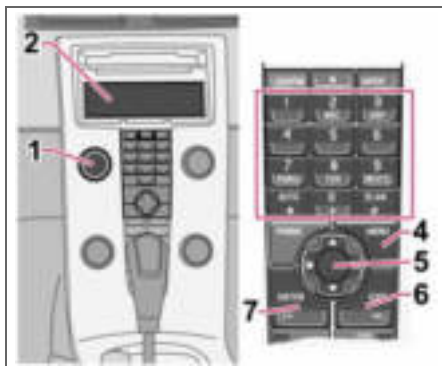

Infotainment is a system that integrates the audio system and the phone¹. The infotainment system can be easily operated using the control panel or the steering wheel keypad¹, see page 54. The display (2) shows messages and information on the current function.

Audio system

On/Off

POWER (1) switches the audio system on or off. If the audio system is active when the ignition key is turned to position **0** then it con-

¹ Option

tinues to be active until the key is removed from the ignition switch. The audio system is started automatically the next time the key is turned to position **I**.

Menus

Some infotainment system functions are controlled via a menu system. The current menu level is shown at the top right of the display. Menu options are shown in the middle of the display.

- **MENU** (4) leads to the menu system.
- Up/down with the navigation button (5) moves between menu options.
- **ENTER** (7) selects or activates/deactivates a menu option.
- **EXIT** (6) leads back one step in the menu structure. A long press on **EXIT** will exit the menu system.

Shortcuts

Menu options are numbered and can also be selected directly with the keypad (3).

Equipment

The audio system can be equipped with different options and different versions. There are three audio system versions: Performance, High Performance and Premium Sound. FM and AM radio with RDS and CD player is however included in each version.

Dolby Surround Pro Logic II

Dolby Surround Pro Logic II² distributes the two stereo audio channels to left, centre, right and rear speakers. This provides a more realistic sound quality than that provided by standard two-channel stereo.



Dolby Surround Pro Logic II and the Dolby icon are trademarks of Dolby Laboratories Licensing Corporation. The Dolby Surround Pro Logic II System is manufactured under license from Dolby Laboratories Licensing Corporation.

² Premium Sound



Audio functions

Audio controls

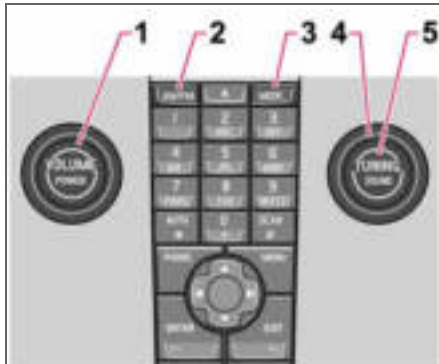

1. **VOLUME** – Knob
2. **AM/FM** – Audio source selection
3. **MODE** – Audio source selection, CD/AUX
4. **TUNING** – Knob
5. **SOUND** – Button

Volume

Use **VOLUME** (1) or the steering wheel keypad to regulate the volume, see page 54. Audio volume adjusts automatically depending on vehicle speed, see page 198.

Audio source selection

Repeatedly pressing **AM/FM** switches between **FM1**, **FM2** and **AM**. Repeatedly pressing **MODE** switches between **CD** and **AUX**.

AUX¹

The AUX input can be used for connecting an MP3 player for example.

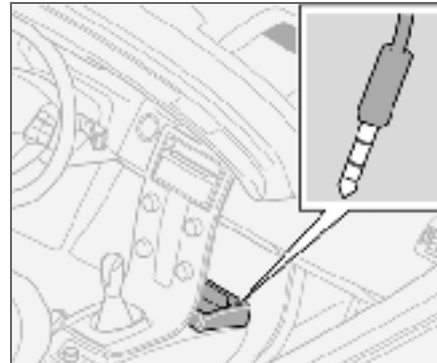

Input for external audio source (AUX) 3.5 mm

i NOTE

The audio quality may be impaired if the player is charged while the audio system is in AUX mode. In which case, avoid charging the player.

¹ High Performance and Premium Sound.

Sometimes the AUX external audio source can be heard at a different volume to the internal audio sources, e.g. the CD player. If the audio volume of the external audio source is too high then the sound quality can be impaired. Prevent this by adjusting the input volume of the AUX input.

- Set the audio system in AUX mode using **MODE**.
- Press **MENU** and then **ENTER**.
- Scroll to **AUX input Volume** and press **ENTER**.
- Turn **TUNING** or press right/left on the navigation button.

Audio settings

Adjusting audio settings

Repeatedly pressing **SOUND** browses between the following alternatives. Adjust by turning **TUNING**.

- **BASS** – Bass level.
- **TREBLE** – Treble level.
- **FADER** – Balance between the front and rear speakers.
- **BALANCE** – Balance between the left and right-hand speakers.



Audio functions

- **CENTRE**¹ – Level for centre speaker. Three channel stereo or Pro Logic II must be activated before adjustment is possible. See page 198.
- **SURROUND**¹ – Level for surround. Pro Logic II must be activated before adjustment is possible. See page 198.

Surround



Surround settings¹ govern the spatial perception of the sound. Settings and activating/deactivating are separate for each audio source.

The Dolby icon in the display indicates that Dolby Pro Logic II is active. There are three different settings for surround sound:

- **Pro Logic II**
- **3 channel**
- **Off** – 2-channel stereo.

Activating/deactivating surround sound

- Press **MENU** and then **ENTER**.
- Scroll to **Audio settings** and press **ENTER**.
- Scroll to **Surround FM/AM/CD/AUX** and press **ENTER**.

¹ Premium Sound

- Scroll to **Pro Logic II**², **3 channel** or **Off** and press **ENTER**.

Equalizer front/rear

The equalizer³ can be used to adjust different frequency bands separately.

Adjusting the equalizer

- Press **MENU** and then **ENTER**.
- Scroll to **Audio settings** and press **ENTER**.
- Scroll to **Equalizer front** or **Equalizer rear** and press **ENTER**.
- The graphic on the display indicates the audio level of the frequency in question.
- Adjust the level with **TUNING** (4) or up/down on the navigation button. Additional frequencies can be selected using the left/right navigation button.
- Use **ENTER** to save or **EXIT** to close.

Automatic volume control

The auto volume control function allows the audio volume to increase as the speed of the car increases. There are three levels to choose from⁴: **Low**, **Medium** and **High**.

² Not available in AM and FM mode.

³ Certain audio systems.

⁴ Not Performance Sound.

Adjusting automatic volume control

- Press **MENU** and then **ENTER**.
- Scroll to **Audio settings** and press **ENTER**.
- Scroll to **Automatic volume control** and press **ENTER**.
- Scroll to **Low**, **Medium** or **High** and press **ENTER**.



Radio functions

Radio controls

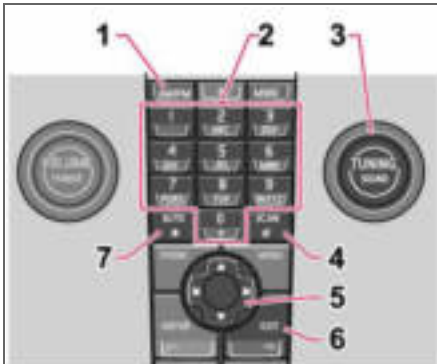

1. **FM/AM** – Wavelength selection
2. Station presets
3. **TUNING** – Knob for station searches
4. **SCAN** – Scanning
5. Navigation button – Tuning and menus
6. **EXIT** – Cancel current function
7. **AUTO** – Automatic storage of stations

Tuning

Automatic tuning

- Select wavelength using **AM/FM** (1).
- Give a brief press, left or right, on the navigation button (5).

Manual tuning

- Select wavelength using **AM/FM** (1).
- Adjust the frequency by turning **TUNING** (3).

Tune into a station with a long press (left or right) on the navigation button or by using the steering wheel keypad:

- Hold the right or left side of the navigation button depressed until the desired frequency appears on the display.

As long as the frequency graphic appears on the display, searching can be resumed by briefly pressing the navigation button (left or right) (5)

Storing stations

Ten station presets can be stored per wavelength. FM has two memories for presets: **FM1** and **FM2**. Preset stations are selected using the preset buttons (2) or the steering wheel keypad.

Storing stations manually

- Tune into a station.
- Hold a station preset button depressed until the message **Station stored** appears on the display.

Automatic storage of stations

AUTO (7) seeks out the ten strongest radio stations and stores them automatically in a separate memory. The function is especially useful in areas where the radio stations and their frequencies are unfamiliar.

Starting automatic storage of stations

- Select wavelength using **AM/FM** (1).
- Hold **AUTO** (7) depressed until **Autostoring...** appears on the display.

Once **Autostoring...** disappears from the display, the stations are stored. The radio continues in Auto mode and **Auto** appears on the display. The automatically stored presets can now be selected using the preset buttons (2).

Cancelling automatic storage of stations

- Press **EXIT** (6).

Selecting an autostored preset

Allowing the radio to remain in Auto mode provides access to the autostored presets.

- Briefly press **AUTO** (7).
- Auto** appears on the display.
- Press a preset button (2).

The radio remains in Auto mode until it is exited by a brief press on **AUTO** (7), **EXIT** (6) or **AM/FM** (1).



Radio functions

Storing autostored presets in another memory

An autostored preset can be transferred to the FM or AM memory.

- Briefly press **AUTO** (7).

Auto appears on the display.

- Press a preset button.
- Press the button under which the station will be stored and hold it depressed until the message **Station stored** appears on the display.

The radio exits Auto mode and the stored station can be selected as a preset.

Scanning

SCAN (4) automatically searches through a wavelength for strong stations. When a station is found, it is played for approx. eight seconds before scanning is resumed.

Activating/deactivating Scan

- Select wavelength using **AM/FM**.
- Press **SCAN** to activate.

SCAN appears on the display. Close using **SCAN** or **EXIT**.

Storing a station

A desired station can be stored as a preset while Scan is active.

- Press a preset button and hold it depressed until the message **Station stored** appears on the display.

Scan is interrupted and the stored station can be selected as a preset.

RDS functions

Radio Data System – RDS links FM transmitters into a network. An FM transmitter in such a network sends information that gives an RDS radio the following functions:

- Automatically switches to a stronger transmitter if reception in the area is poor.
- Searches for programme form, such as traffic information or news.
- Receives text information on current radio programme.

Some radio stations do not use RDS or only some if its functionality.

Programme functions

In FM mode, the radio can search for stations with certain programme types. If a required programme type is located the radio can switch stations interrupting the audio source currently in use. For example, if the CD player is in use, it is paused. The interrupting transmission is played at a preset audio volume, see page 202. The radio returns to the previous audio source and audio volume when the set programme type is no longer broadcast.

The programme functions alarm (**ALARM**), traffic information (**TP**), news (**NEWS**), and programme types (**PTY**) interrupt one another in order of priority, where alarm has the highest priority and programme types has the lowest. For further programme interruption settings, see EON and REG on page 202. The programme functions are modified via the menu system, see page 196.

Returning to the interrupted audio source

Press **EXIT** to return to the interrupted audio source.

Alarm

This function is used to warn of serious accidents and catastrophes. The alarm cannot be temporarily interrupted or deactivated. The message **ALARM!** appears on the display when an alarm message is transmitted.

Traffic information – TP



This function allows traffic information sent within a set station's RDS network to break through. **TP** indicates that the function is activated.

If the set station can send traffic information then **TP** appears on the display.

Activating/deactivating TP

- Press **MENU** and then **ENTER**.



Radio functions

- Scroll to **TP** and press **ENTER**.

TP from current station/all stations

The radio can interrupt with traffic information from only the set (current) station or from all stations.

- Select an FM station.
- Press **MENU** and then **ENTER**.
- Scroll to **Advanced radio settings** and press **ENTER**.
- Scroll to **TP** and press **ENTER**.
- Scroll to **TP Station** and press **ENTER**.

Either **TP from current station** or **TP from all stations** will appear on the display.

- Press **ENTER**.

Activating/deactivating TP search

TP search is useful during long journeys while an audio source other than the radio is being played. The function automatically searches for traffic information within different RDS networks.

- Press **MENU** and then **ENTER**.
- Scroll to **Advanced radio settings** and press **ENTER**.
- Scroll to **TP** and press **ENTER**.
- Scroll to **TP search** and press **ENTER**.

News

NEWS

This function allows news broadcasts within a set station's RDS network to break through. The message **NEWS** indicates that the function is active.

Activating/deactivating News

- Press **MENU** and then **ENTER**.
- Scroll to **News** and press **ENTER**.

News from current station/all stations

The radio can interrupt with news from only the set (current) station or from all stations.

- Select an FM station.
- Press **MENU** and then **ENTER**.
- Scroll to **Advanced radio settings** and press **ENTER**.
- Scroll to **News station** and press **ENTER**.

Either **News from current station** or **News from all stations** will appear on the display.

- Press **ENTER**.

Programme types – PTY

PTY

The PTY function can be used to select different programme types, such as **pop music** and **serious classic**. The PTY symbol indicates that the function is active. This

function allows programme types broadcast within a set station's RDS network to break through.

Activating/deactivating PTY

- Select **FM1** or **FM2** with **FM/AM**.
- Press **MENU** and then **ENTER**.
- Scroll to **PTY** and press **ENTER**.
- Scroll to **Select PTY** and press **ENTER**.

A list of programme types appears: **Current affairs**, **Information** etc. The PTY function is activated by selecting programme types and deactivated by clearing all PTYs.

- Select the desired programme types or **Clear all PTY**

Search PTY

This function searches the entire wavelength for the selected programme type.

- Activate PTY.
- Press **MENU** and then **ENTER**.
- Scroll to **PTY** and press **ENTER**.
- Scroll to **Search PTY** and press **ENTER**.

If the radio finds any of the selected programme types then the display shows **>| To seek**. Press the navigation button to the right to continue searching for another broadcast of the selected programme types.



Radio functions

Display of programme type

The programme type of the current station can be shown on the display.

NOTE

Not all radio stations support this function.

Activating/deactivating display

- Press **MENU** and then **ENTER**.
- Scroll to **PTY** and press **ENTER**.
- Scroll to **Show PTY** and press **ENTER**.

Radio text

Some RDS stations transmit information on programme content, artists, etc. This information can be shown on the display.

Activating/deactivating radio text

- Press **MENU** and then **ENTER**.
- Scroll to **Radio text** and press **ENTER**.

Automatic frequency update – AF

The AF function selects one of the strongest transmitters for a set station. The radio may sometimes need to search through the entire FM wavelength to find a strong transmitter. If this occurs, the radio mutes and **PI Seek Exit to cancel** appears on the display.

Activating/deactivating AF

- Press **MENU** and then **ENTER**.
- Scroll to **Advanced radio settings** and press **ENTER**.
- Scroll to **AF** and press **ENTER**.

Regional radio programmes – REG

REG This function causes the radio to continue with a regional transmitter even if its signal strength is low. **REG** indicates that the function is active. The regional function is normally deactivated.

Activating/deactivating REG

- Press **MENU** and then **ENTER**.
- Scroll to **Advanced radio settings** and press **ENTER**.
- Scroll to **Regional** and press **ENTER**.

Enhanced Other Networks – EON

The EON function is especially useful in urban areas with many regional radio stations. It allows the distance between the car and the radio station transmitter to determine when programme functions should interrupt the current audio source.

- **Local** – interrupts only if the radio station transmitter is close.

- **Distant**¹ – interrupts if the station transmitter is far away, even if there is a lot of static.
- **Off** – no interruption for programmes from other transmitters.

Activating/deactivating EON

- Press **MENU** and then **ENTER**.
- Scroll to **Advanced radio settings** and press **ENTER**.
- Scroll to **EON** and press **ENTER**.
- Scroll to **Local**, **Distant** or **Off** and press **ENTER**.

Resetting RDS functions

Resets all radio settings to the original factory settings.

- Press **MENU** and then **ENTER**.
- Scroll to **Advanced radio settings** and press **ENTER**.
- Scroll to **Reset all** and press **ENTER**.

Volume control, programme types

The interrupting programme types are heard at the volume selected for each programme type. If the volume level is adjusted during the programme interruption, the new level is saved until the next programme interruption.

¹ Default/Factory setting.



CD functions

CD function controls

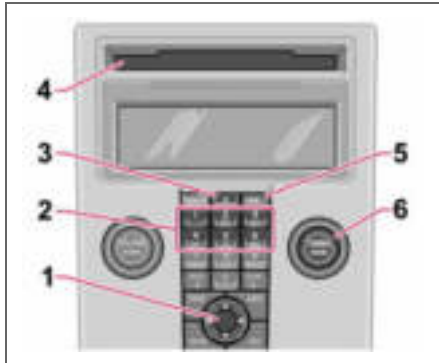

1. Navigation button – Fast forward/rewind, track selection and menus
2. CD changer position selection¹
3. CD insertion/eject
4. CD insertion/eject slot
5. **MODE** – Audio source selection CD and AUX²
6. **TUNING** – Knob for track selection

Starting playback (CD player)

If a music CD is in the player when the audio system is in CD mode then playback is start-

¹ Option

² High Performance and Premium Sound

ed automatically. Otherwise, load a disc and change to CD mode by pressing **MODE**.

Starting playback (CD changer)

If a CD position with a music CD is already selected when the audio system is activated then playback starts automatically. Otherwise change to CD changer mode using **MODE** and select a disc with the number buttons **1–6** or Up/Down on the navigation button.

Inserting a CD (CD changer)

- Select an empty position with buttons **1–6** or Up/Down on the navigation button.

An empty position is marked on the display. The text **Insert disc** shows that a new disc can be inserted. The CD changer can hold up to six CDs.

- Insert a CD in the slot of the CD changer.

CD eject

A CD will stay in the ejected position for approx. 12 seconds. Following which it is re-inserted in the player and playback continues.

Eject individual discs by pressing the eject button (3).

Eject all discs with a long press on the eject button. The entire magazine is emptied disc by disc. The message **Eject all** is shown in the display.

Pause

If the volume is turned down completely, the CD player is stopped. The player is restarted when volume is increased.

Audio files²



The CD player also supports MP3 and WMA format audio files.

When a CD containing audio files is inserted into the player the disc's directory structure is read in. It may take a while before playback starts due to the quality of the disc.

i NOTE

Certain types of copy-protected audio files cannot be read by the player.

Navigation and playback

If a disc containing audio files is inside the CD player then **ENTER** leads to the disc's directory structure. The directory structure is navigated in the same way as the audio system's menu structure. Audio files have the symbol  and directories have the symbol . Start audio file playback with **ENTER**.

When the playback of a file is finished the playback of the other files in the same directory continues. Directory change takes place



CD functions

automatically when all files in the current directory have been played back.

Press left/right on the navigation button if the display is not wide enough to show the whole audio file name.

Fast-wind/change CD tracks and audio files

Short presses right/left on the navigation button are used to scroll between CD tracks/audio files. Long presses are used to fast-wind CD tracks/audio files. **TUNING** (or the steering wheel keypad) can also be used for this purpose.

Scan CD

This function plays the first ten seconds of each CD track/audio file. Press **SCAN** to activate. Interrupt with **EXIT** or **SCAN** to continue playback of the current CD track/audio file.

Random

This function plays the tracks in random order. The random CD tracks/audio files can be scrolled through in the normal way.



NOTE

It is only possible to scroll between random CD tracks on the current disc.

Different messages appear on the display depending on which random function has been selected.

- **RANDOM** means that the tracks from only one music CD are played
- **RND ALL** means that all tracks on all music CDs in the CD changer are played.
- **RANDOM FOLDER** means that the audio files in a directory on the current CD are played.

Activating/deactivating (CD player)

- If a normal music CD is being played:
- Press **MENU** and then **ENTER**.
- Scroll to **Random** and press **ENTER**.

If a disc with audio files is being played:

- Press **MENU** and then **ENTER**.
- Scroll to **Random** and press **ENTER**.
- Scroll to **Folder** or **Disc** and press **ENTER**.

Activating/deactivating (CD changer)

If a normal music CD is being played:

- Press **MENU** and then **ENTER**.
- Scroll to **Random** and press **ENTER**.
- Scroll to **Single disc** or **All discs** and press **ENTER**.

The option **All discs** only applies to the music CDs in the changer.

If a CD with audio files is being played:

- Press **MENU** and then **ENTER**.
- Scroll to **Random** and press **ENTER**.
- Scroll to **Single disc** or **Folder** and press **ENTER**.

The function is deactivated when another CD is selected.

Disc text

If title information is stored on a music CD it can be shown on the display¹.

Activating/deactivating

- Start CD playback.
- Press **MENU** and then **ENTER**.
- Scroll to **Disc text** and press **ENTER**.

CDs

Using low quality CD discs could result in poor or non-existent sound.



IMPORTANT

Use only standard discs (12 cm in diameter). Do not use CDs with adhesive disc labels. The heat in the CD player may cause the label to come off, damaging the CD player.

¹ Only applies to CD changer.

**Menu structure – audio system****FM menu**

1. News
2. TP
3. PTY
4. Radio text
5. Advanced radio settings
6. Audio settings¹

2. News
3. TP
4. Audio settings¹

AM menu

1. Audio settings¹

CD menu

1. Random
2. News
3. TP
4. Disc text
5. Audio settings¹

CD changer menu

1. Random
2. News
3. TP
4. Disc text
5. Audio settings¹

AUX menu

1. AUX volume

¹ Certain audio systems.



10 Infotainment system

Phone functions (option)

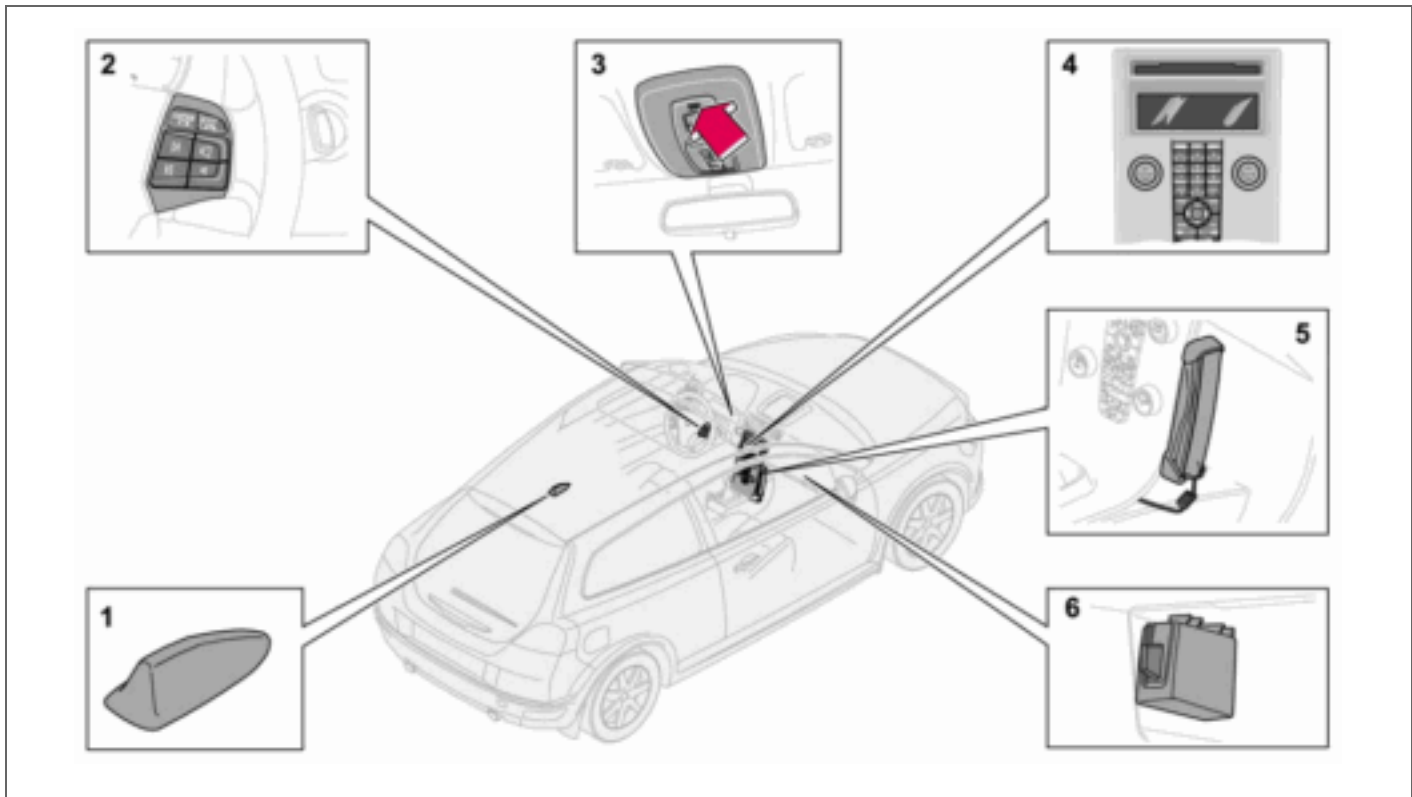

Phone system components



Phone functions (option)

Phone system components

1. Antenna

2. Steering wheel keypad

Most phone system functions can be accessed via the keypad. See page 208.

3. Microphone

The handsfree microphone is integrated in the roof console beside the rearview mirror.

4. Centre console control panel

All phone functions (except call volume) can be regulated via the control panel.

5. Privacy handset (option certain markets)

6. SIM card reader

General

- Always put traffic safety first.
- If the driver needs to use the privacy handset, park the car in a safe place first.
- The phone system must be switched off when the car is refuelled.
- Switch off the system near blasting work.

- Only entrust phone system servicing to an authorised Volvo workshop.

Emergency calls

Emergency calls to alarm centres can be made without a SIM card as long as there is coverage by a GSM operator.

Making an emergency call

- Activate the phone.
- Ring the emergency number that applies to your region (within EU: 112).
- Press **ENTER**.

IDIS

(Intelligent Driver Information System) The IDIS system allows incoming phone calls and text (SMS) messages to be delayed so that the driver can concentrate on driving. Incoming calls and text messages can be delayed five seconds before they are connected. Missed calls are shown on the display. IDIS can be deactivated using menu function 5.6.2. See page 214.

SIM card

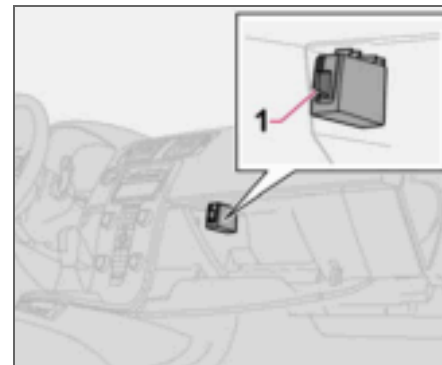

The phone can only be used with a valid SIM card (Subscriber Identity Module). The card is available from various network operators. Contact your network operator if you experience difficulties with the SIM card.

Double SIM cards

Many network operators offer two SIM cards for the same phone number. The extra SIM card can be used in the car.

Inserting the SIM card

- Switch off the phone and open the glove-box.



Phone functions (option)

- Pull out the SIM card holder (1) in the SIM card reader.
- Position the SIM card in the holder with the metal surface visible. The bevelled edge of the SIM card should align with the bevel of the SIM card holder.
- Carefully press in the SIM card holder.

Menus

Page 196 describes how to control phone functions with the menu system.

Traffic safety

For safety reasons, parts of the phone menu system cannot be accessed at speeds in excess of 8 km/h. Only activities started in the menu system can be completed. The speed limiter can be deactivated using menu function 5.6.1 Menu lock, see page 213.

Phone controls

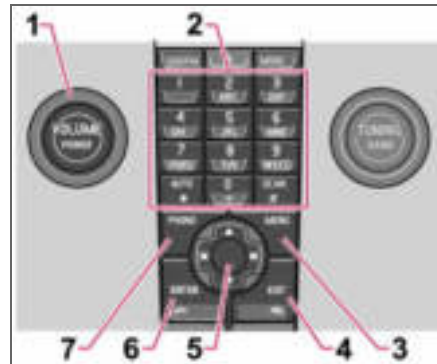

Centre console control panel

1. **VOLUME** – Control the background volume from the radio, for example, during a call.
2. Number and letter buttons
3. **MENU** – Opens the main menu
4. **EXIT** – End/refuse calls, clear entered characters
5. Navigation button – Scroll in menus and character rows
6. **ENTER** – Accept calls, activate the phone from standby mode
7. **PHONE** – On/off and standby mode

Steering wheel keypad

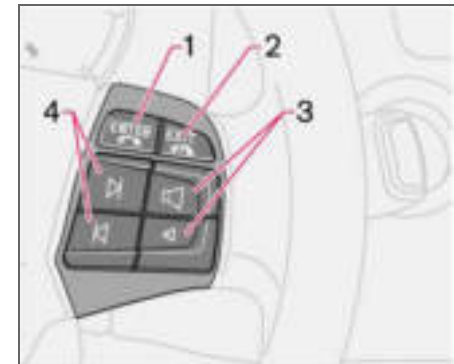

When the phone is active, the steering wheel keypad is locked to phone functions. To control the audio system, the phone must be in standby mode.

1. **ENTER** – Works the same as on the control panel.
2. **EXIT** – Works the same as on the control panel
3. Call volume – Increase/decrease
4. Navigation buttons – Scroll in menus



Phone functions (option)

On/Off

A handset appears in the display when the phone system is active or in standby mode. If the ignition key is turned to position **0** when the phone is in one of these modes, the phone automatically resumes this mode the next time the key is turned to position **I** or **II**.

Activating the phone system

Phone system functions can only be used when the phone is in active mode.

- Press **PHONE**.
- Enter the PIN code (if necessary) and press **ENTER**.

Deactivating the phone system

No calls can be received when the phone is deactivated.

- Hold **PHONE** depressed until the phone is activated.

Standby

In standby mode, the audio system can be in use while calls are received. However, it is not possible to make calls when in standby mode.

Putting the phone in standby mode

The phone must first be in active mode before it can be put in standby mode.

- Press **PHONE** or **EXIT**.

Activating from standby mode

- Press **PHONE**.

Making and receiving calls

If the privacy handset is raised when a phone call is started, the sound will come from the handsfree system. For information on switching between privacy handset and handsfree during a call, see page 211.

To call

- Activate the phone system (if necessary).
- Dial the number or use the phone book, see page 211.
- Press **ENTER** or lift the handset. Release the handset by pressing it down.

Receiving a call

For Auto answer, see menu option 4.3, page 213.

- Press **ENTER** or lift the handset. Release the handset by pressing it down.

Ending a call

- Press **EXIT** or hang up the handset.

Refusing a call

- Press **EXIT**.

Call waiting

A two-tone signal during a phone call indicates that there is another incoming call. Answer? appears on the **display**. The call can be refused or taken in the normal manner. If the incoming call is taken, the previous call is put on hold.

Putting a call on hold/resuming a call

- Press **MENU**.
- Scroll to **Hold** or **Hold off** and press **ENTER**.

Dialling a third party

- Put the call on hold.
- Dial the number of the third party.

Switching between calls

- Press **MENU**.
- Scroll to **Swap** and press **ENTER**.

Starting a conference call

A conference call consists of at least three parties that can talk to one another. Once a conference call has been initiated, no more parties can be connected. All calls are ended when a conference call is ended.

- Start two phone calls
- Press **MENU**.
- Scroll to **Join** and press **ENTER**.



Phone functions (option)

Volume

The phone uses the driver's door or centre speaker¹.

Call volume



Call volume is regulated with the buttons of the steering wheel keypad.

If the privacy handset is used, volume is regulated with a wheel on the side of

the handset.

Audio system volume

Audio system volume is temporarily lowered during a phone call. Once the call is ended the previous volume is resumed. If the volume is regulated during the call, the new level is retained once the call is ended. Sound can also be automatically muted during a phone call, see menu 5.5.3, page 214. This function is only available with the Volvo integrated phone system.

Entering text

Text is entered using the phone keypad.

- Press the button with the desired character - once for the first character on the

button, twice for the second, etc. See table.

- Press 1 for a space. If two characters in a row are to be entered using the same button, press * or wait a few seconds.

A short press on **EXIT** deletes an input character. A long press on **EXIT** will clear all entered characters.

| | |
|---|--|
| 1 | space 1- ? ! , . : " ' () |
| 2 | a b c 2 ä å à æ ç |
| 3 | d e f 3 è é |
| 4 | g h i 4 ì |
| 5 | j k l 5 |
| 6 | m n o 6 ñ ò ò Ø |
| 7 | p q r s 7 ß |
| 8 | t u v 8 ü ù |
| 9 | w x y z 9 |
| * | Used if two characters are to be entered with the same button. |
| 0 | + 0 @ * # & \$ £ / % |
| # | Switch between upper and lower case. |

Handling numbers

Calling the last number dialed

The phone automatically stores the last phone numbers dialed.

- Press **ENTER**.
- Scroll to a number and press **ENTER**.

Phone book

If the phone book contains a live caller's contact information then this is shown in the display. Contact information can be stored on the SIM card and in the phone.

Storing contacts in the phone book

- Press **MENU**.
- Scroll to **Phone book** and press **ENTER**.
- Scroll to **New number** and press **ENTER**.
- Enter a name and press **ENTER**.
- Enter a number and press **ENTER**.
- Scroll to **SIM card** or **Phone** and press **ENTER**.

Searching for contacts in the phone book

Use the down arrow of the navigation button instead of **MENU** for direct access to the Search menu.

- Press **MENU**.
- Scroll to **Phone book** and press **ENTER**.

¹ Premium Sound.

**Phone functions (option)**

- Scroll to **Search** and press **ENTER**.
- Enter the first few letters of the item and press **ENTER**, or simply press **ENTER**.
- Scroll to an item and press **ENTER**.

Copying entries between the SIM card and Phone book

- Press **MENU**.
- Scroll to **Phone book** and press **ENTER**.
- Scroll to **Copy all** and press **ENTER**.
- Scroll to **SIM to phone** or **Phone to SIM** and press **ENTER**.

Deleting contacts from the phone book

- Press **MENU**.
- Scroll to **Phone book** and press **ENTER**.
- Scroll to **Search** and press **ENTER**.
- Enter the first few letters of the item and press **ENTER**, or simply press **ENTER**.
- Scroll to the item to be erased and press **ENTER**.
- Scroll to **Erase** and press **ENTER**.

Erase all contacts

- Press **MENU**.
- Scroll to **Phone book** and press **ENTER**.
- Scroll to **Erase SIM** or **Erase phone** and press **ENTER**.

If required, enter phone code. The factory-set default code is 1234.

Speed dial

A keypad button (1- 9) can be used as a speed dial number for a contact in the phone book.

- Press **MENU**.
- Scroll to **Phone book** and press **ENTER**.
- Scroll to **One-key dial** and press **ENTER**.
- Scroll to **Select numbers** and press **ENTER**.
- Scroll to the digit of the keypad button for the speed dial number and press **ENTER**.
- Enter the first few letters of the item and press **ENTER**, or simply press **ENTER**.
- Scroll to an item and press **ENTER**.
- Hold EXIT depressed to leave the menu system.

Calling using speed dial

- Hold the desired keypad button for approx. two seconds or briefly press the button and then **ENTER**.

NOTE

When the phone is switched on, it takes a while before speed dialling is available.

To use the speed dial function **One-key dial** must be activated in the **Phone book** menu, see page 215.

Calling from the phone book

- Press **MENU**.
- Scroll to **Phone book** and press **ENTER**. All contacts in the phone book memory are displayed. The number of contacts displayed can be reduced by entering part of the contact's name.
- Scroll to a contact and press **ENTER**.

NOTE

Press **ENTER** to dial.

Functions during a call

Several functions are available during a call. Some functions can only be used when a call is on hold.

Press **MENU** to access the In-call menu and scroll to one of the following alternatives:

- **Mute/Mute off** – Mute mode.
- **Hold/Hold off** – Put a call on hold or resume a call.
- **Handsfree/Handset** – Use handsfree or the privacy handset.
- **Phone book** – Access the phone book.
- **Join** – Conference calling (available if more than three parties are connected)



Phone functions (option)

- **Swap** – Switch between two calls (available if up to three parties are connected).

SMS – Short Message Service

Reading SMS

- Press **MENU**.
- Scroll to **Messages** and press **ENTER**.
- Scroll to **Read** and press **ENTER**.
- Scroll to a message and press **ENTER**.

The message text is shown in the display. Additional selections can be made by pressing **ENTER**. Hold **EXIT** depressed to leave the menu system.

Writing and sending

- Press **MENU**.
- Scroll to **Messages** and press **ENTER**.
- Scroll to **Write new** and press **ENTER**.
- Enter text and press **ENTER**.
- Scroll to **Send** and press **ENTER**.
- Enter a phone number and press **ENTER**.

IMEI number

In order to block a phone the network provider must be advised of the phone's IMEI number. This is a 15 digit serial number that is programmed in the phone. Dial ***#06#** to show this number in the display. Write it down and keep it in a safe place.

Specifications

| | |
|-----------------------------|------------------|
| Output | 2 W |
| SIM card | Small |
| Memory entries | 255 ¹ |
| SMS (Short Message Service) | Yes |
| Data/Fax | No |
| Dualband (900/1800 MHz) | Yes |

¹The capacity of the SIM card's memory varies depending on the subscription.



Menu structure – phone

Overview

1. Call register

- 1.1. Missed calls
- 1.2. Received calls
- 1.3. Dialed no.
- 1.4. Erase list
 - 1.4.1. All calls
 - 1.4.2. Missed calls
 - 1.4.3. Received calls
 - 1.4.4. Dialed no.
- 1.5. Call duration
 - 1.5.1. Last call
 - 1.5.2. Call count
 - 1.5.3. Total time
 - 1.5.4. Reset timers

2. Messages

- 2.1. Read
- 2.2. Write
- 2.3. Message sett
 - 2.3.1. SMSC number
 - 2.3.2. Validity time
 - 2.3.3. Message type

3. Phone book

- 3.1. New number
- 3.2. Search
- 3.3. Copy all
 - 3.3.1. SIM to phone
 - 3.3.2. Phone to SIM
- 3.4. One-key dial
 - 3.4.1. Active
 - 3.4.2. Select numbers
- 3.5. Erase SIM
- 3.6. Erase phone
- 3.7. Memory status

4. Call options

- 4.1. Send my no.
- 4.2. Call waiting
- 4.3. Auto answer
- 4.4. Auto re-dial
- 4.5. Diversions
 - 4.5.1. All calls
 - 4.5.2. When engag.
 - 4.5.3. Not answered
 - 4.5.4. Not reachable
 - 4.5.5. Fax calls
 - 4.5.6. Data calls
 - 4.5.7. Cancel all

5. Phone sett.

- 5.1. Network
 - 5.1.1. Auto
 - 5.1.2. Manual select
- 5.2. Language
 - 5.2.1. English UK
 - 5.2.2. English US
 - 5.2.3. Español
 - 5.2.4. Français CAN
 - 5.2.5. Français FR
 - 5.2.6. Italiano
 - 5.2.7. Nederlands
 - 5.2.8. Português BR
 - 5.2.9. Português P
 - 5.2.10. Suomi
 - 5.2.11. Svenska
 - 5.2.12. Dansk
 - 5.2.13. Deutsch
- 5.3. SIM security
 - 5.3.1. On
 - 5.3.2. Off
 - 5.3.3. Auto
- 5.4. Edit codes
 - 5.4.1. PIN code
 - 5.4.2. Phone code



Menu structure – phone

- 5.5. Sounds
 - 5.5.1. Ring volume
 - 5.5.2. Ring signal
 - 5.5.3. Mute radio
 - 5.5.4. Msg. beep
- 5.6. Traff. safety
 - 5.6.1. Menu lock
 - 5.6.2. IDIS
- 5.7. Factory sett.

Description of menu options

1. Call register

1.1. Missed calls

List of missed calls. You can choose to call, erase or store the number in the phone book.

1.2. Received calls

List of received calls. You can choose to call, erase or store the number in the phone book.

1.3. Dialed no.

List of dialed numbers. You can choose to call, erase or store the number in the phone book.

1.4. Erase list

Erase the lists found in the menus 1.1, 1.2 and 1.3 as below.

- 1.4.1. All
- 1.4.2. Missed
- 1.4.3. Received
- 1.4.4. Dialed no.

1.5. Call duration

Duration of all calls or of the most recent call. The phone code is required to reset the call timer (see menu 5.4).

- 1.5.1. Last call
- 1.5.2. Call count
- 1.5.3. Total time
- 1.5.4. Reset timers

2. Messages

2.1. Read

Received text messages. Select whether to erase, forward, change or save the entire message or parts of it.

2.2. Write

Write a message using the keypad. Choose whether to save or send it.

2.3. Message sett

Enter the number (SMSC number) of the message centre to which messages are to be transferred as well as how long they are to be saved at the message centre. Contact your network operator for information on message settings. Normally, these settings should not be altered.

- 2.3.1. SMSC number
- 2.3.2. Validity time
- 2.3.3. Message type

3. Phone book

3.1. New number

Store names and phone numbers in the phone book, see page 210.

3.2. Search

Search for a name in the phone book.



Menu structure – phone

3.3. Copy all

Copy phone numbers and names from the SIM card to the phone memory.

- 3.3.1. From SIM to phone memory
- 3.3.2. From phone to SIM memory

3.4. One-key dial

A number stored in the phone book can be stored as a speed dial number.

3.5. Erase SIM

Erase the entire SIM card memory.

3.6. Erase phone

Erase the entire phone memory.

3.7. Memory status

Shows how many positions are occupied in the SIM card and phone memory. The table shows how many of the total number of positions are occupied, e.g. 100 (250).

4. Call options

4.1. Send my no.

Displays or hides your phone number to/from the person you call. Contact your network operator regarding ex-directory numbers.

4.2. Call waiting

Be alerted during a phone call that there is another incoming call.

4.3. Auto answer

Automatically answers incoming calls.

4.4. Auto re-dial

Calls a previously engaged number.

4.5. Diversions

Choose when and what type of calls are to be diverted to a specified phone number.

- 4.5.1. All calls (this setting only applies during the call in progress).
- 4.5.2. When engag.
- 4.5.3. Not answered
- 4.5.4. Not reachable
- 4.5.5. Fax calls
- 4.5.6. Data calls
- 4.5.7. Cancel all

5. Phone settings

5.1. Network

Choose a network automatically or manually. The selected network is shown in the display in the phone's basic mode.

- 5.1.1. Auto
- 5.1.2. Manual select

5.2. Language

Select the phone language.

- 5.2.1. English UK
- 5.2.2. English US

- 5.2.3. Español
- 5.2.4. Français CAN
- 5.2.5. Français FR
- 5.2.6. Italiano
- 5.2.7. Nederlands
- 5.2.8. Português BR
- 5.2.9. Português P
- 5.2.10. Suomi
- 5.2.11. Svenska
- 5.2.12. Dansk
- 5.2.13. Deutsch

5.3. SIM security

Select if the PIN code should be on, off or if the phone should automatically give the PIN code.

- 5.3.1. On
- 5.3.2. Off
- 5.3.3. Auto

5.4. Edit codes

Change PIN or phone code. Write the codes down and keep them in a safe place.

- 5.4.1. PIN code
- 5.4.2. Phone code. The factory-set phone code 1234 is used until you change to your own code. The phone code is used to reset the call timer.

5.5. Sounds

- 5.5.1. Volume. Adjust the ring tone volume.



5.5.2. Ring signal. There are seven different ring tones.

5.5.3. Mute radio. On/Off

5.5.4. Msg. beep

5.6. Traffic safety

5.6.1. Menu lock. Deactivating the menu lock allows access to the entire menu while driving.

5.6.2. IDIS. If the IDIS function is deactivated, incoming calls are not delayed, regardless of the driving situation.

5.7. Factory sett.

Reset the system's factory settings.



| | |
|------------------------------|-----|
| Type designation | 220 |
| Dimensions and weights | 221 |
| Engine specifications | 224 |
| Engine oil | 226 |
| Fluids and lubricants | 230 |
| Fuel | 232 |
| Catalytic converter | 234 |
| Electrical system | 235 |

01 10

SPECIFICATIONS



11

Type designation

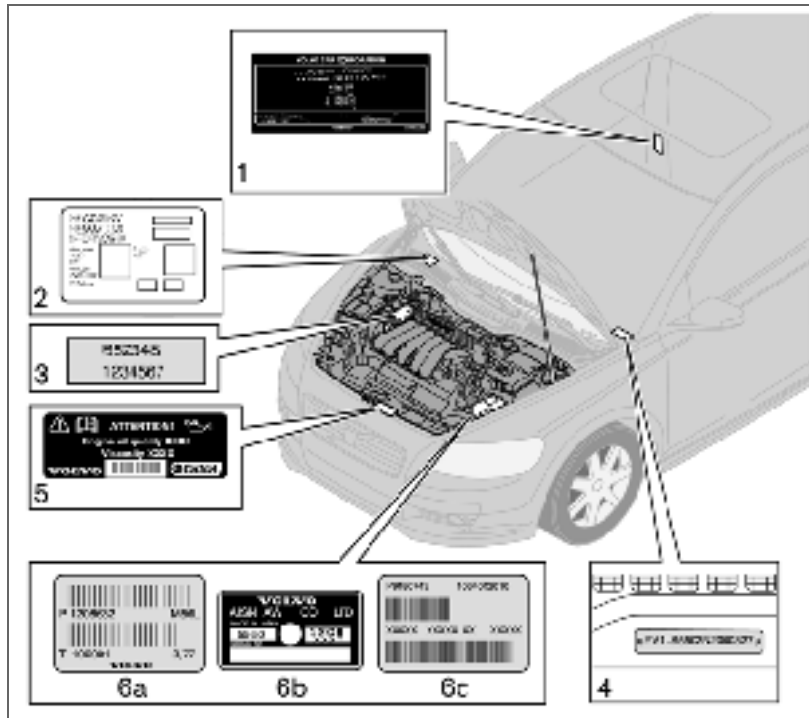

Knowing the car's type designation, vehicle identification and engine numbers can facilitate all contact with a Volvo dealer regarding the car and when ordering spare parts and accessories.

1. Type designation, vehicle identification number, maximum permissible weights, codes for colour and upholstery and type approval number.
2. Decal for parking heater.
3. Engine type designation, component and serial number.
4. VIN number (type and model year designation plus chassis number).
5. Decal for engine oil.
6. Gearbox type designation and serial number:
 - (a) manual gearbox
 - (b), (c) automatic gearbox

Dimensions and weights

Dimensions

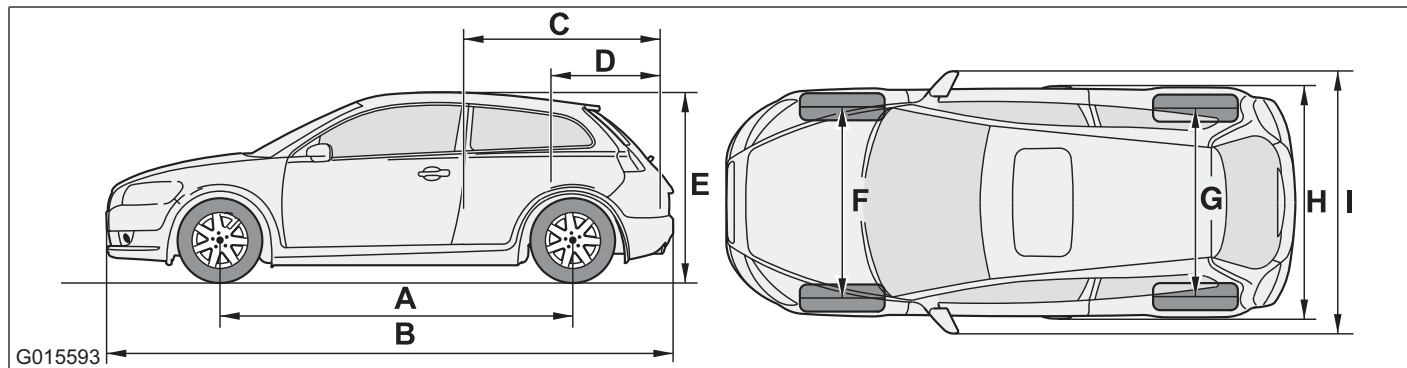

| Position in illustration | Dimensions | cm |
|--------------------------|---------------------------------|-----|
| A | Wheelbase | 264 |
| B | Length | 425 |
| C | Load length, floor, folded seat | 149 |
| D | Load length, floor | 66 |
| E | Height | 145 |
| F | Front track | 155 |
| G | Rear track | 154 |
| H | Width | 178 |
| I | Width including door mirrors | 204 |

11 Specifications

Dimensions and weights

Weights

Kerb weight includes the driver, the fuel tank 90 % full and all fluids. The weight of passengers and accessories, such as a towbar, tow-ball load (when a trailer is hitched, see table), load carriers, and space box etc. influences the payload and must not be included in the kerb weight. Permitted weight (in addition to driver) = Gross vehicle weight – Kerb weight.

WARNING

The car's driving characteristics change depending on how heavily it is loaded and how the load is distributed.

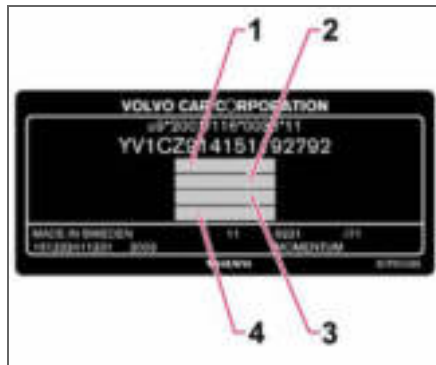

See decal location on page 220.

1. Gross vehicle weight
2. Max. train weight (car+trailer)
3. Max. front axle load
4. Max. rear axle load

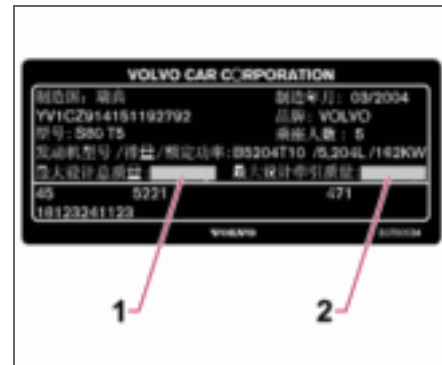

Only for China

1. Gross vehicle weight
 2. Maximum trailer weight
- Maximum load:** See registration document.

| |
|-------------------------------|
| Dimensions and weights |
|-------------------------------|

Max. roof load: 75 kg

| | Maximum braked trailer weight kg | Maximum towball load kg |
|--------|----------------------------------|-------------------------|
| 1.6 | 1200 | 75 |
| 1.6D | 1300 | |
| 1.8 | 1300 | |
| 1.8F | 1300 | |
| 2.0 | 1350 | |
| others | 1500 | |

| Maximum unbraked trailer weight kg | Maximum towball load kg |
|------------------------------------|-------------------------|
| 700 | 50 |

11 Specifications

Engine specifications

| | 1.6 | 1.8 | 1.8F | 2.0 | 2.4i | T5 |
|-----------------------|----------|----------|----------|----------|----------|---------------|
| Engine designation | B4164S3 | B4184S11 | B4184S8 | B4204S3 | B5244S4 | B5254T3 |
| Output (kW/rpm) | 74/6000 | 92/6000 | 92/6000 | 107/6000 | 125/6000 | 162/5000 |
| (hp/rpm) | 100/6000 | 125/6000 | 125/6000 | 145/6000 | 170/6000 | 220/5000 |
| Torque (Nm/rpm) | 150/4000 | 165/4000 | 165/4000 | 185/4500 | 230/4400 | 320/1500-4800 |
| No. of cylinders | 4 | 4 | 4 | 4 | 5 | 5 |
| Bore (mm) | 79 | 83 | 83 | 87 | 83 | 83 |
| Stroke (mm) | 81.4 | 83.1 | 83.1 | 83 | 90 | 93.2 |
| Swept volume (litres) | 1.60 | 1.80 | 1.80 | 1.99 | 2.44 | 2.52 |
| Compression ratio | 11.0:1 | 10.8:1 | 10.8:1 | 10.8:1 | 10.3:1 | 9.0:1 |

Engine type designation, component and serial number can be read on the engine, see page 220.

Engine specifications

| | 1.6D | 2.0D | D5 | D5 |
|-----------------------|----------|----------|----------------------|---------------|
| Engine designation | D4164T | D4204T | D5244T9 ¹ | D5244T8 |
| Output (kW/rpm) | 80/4000 | 100/4000 | 120/5500 | 132/4000 |
| (hp/rpm) | 109/4000 | 136/4000 | 163/5500 | 180/4000 |
| Torque (Nm/rpm) | 240/- | 320/2000 | 340/1750–2750 | 350/1750–3250 |
| No. of cylinders | 4 | 4 | 5 | 5 |
| Bore (mm) | 75 | 85 | 81 | 81 |
| Stroke (mm) | 88.3 | 88 | 93.2 | 93.2 |
| Swept volume (litres) | 1.56 | 2.00 | 2.40 | 2.40 |
| Compression ratio | 18.3:1 | 18.5:1 | 17.0:1 | 17.0:1 |

¹ Belgium

Engine type designation, component and serial number can be read on the engine, see page 220.

11

Engine oil

Adverse driving conditions

Check the oil level more frequently for long journeys:

- towing a caravan or trailer
- in mountainous regions
- at high speeds in temperatures colder than $-30\text{ }^{\circ}\text{C}$ or hotter than $+40\text{ }^{\circ}\text{C}$.

Also check the oil level more often if the car is often driven short distances (less than 10 km) when temperatures are low (below $+5\text{ }^{\circ}\text{C}$).

This can produce abnormally high oil temperature or oil consumption.

Volvo recommends  oil products.



IMPORTANT

In order to fulfil the requirements for the engine's service intervals all engines are filled with a specially adapted synthetic engine oil at the factory. The choice of oil has been made very carefully with regard to service life, starting characteristics, fuel consumption and environmental impact. An approved engine oil must be used in order that the recommended service intervals can be applied. Only use a prescribed grade of oil (see the engine compartment decal) for both filling and oil change, otherwise you will risk affecting service life, starting characteristics, fuel consumption and environmental impact. Volvo Car Corporation disclaims all warranty liability if engine oil of the prescribed grade and viscosity is not used.

Viscosity chart

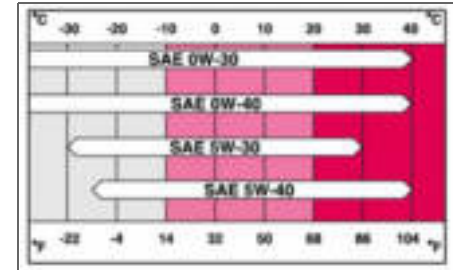

Engine oil

Oil decal



The following applies when this adjacent oil decal is fitted in the car's engine compartment. See location on page 220.

Oil grade: ACEA A3/B3/B4

Viscosity: SAE 0W-30

When driving under adverse conditions, use ACEA A5/B5 SAE 0W-30.

| Engine variant | Filling volume between MIN-MAX (litres) | Volume ¹ (litres) |
|----------------|---|---------------------------------|
| 2.4i B5244S4 | 1.3 | 5.8 |
| T5 B5254T3 | | |

¹ Including filter change.

Engine oil

Oil decal



The following applies when this adjacent oil decal is fitted in the car's engine compartment. See location on page 220.

Oil grade: WSS-M2C913-B

Viscosity: SAE 5W-30

When driving under adverse conditions, use ACEA A5/B5 SAE 0W-30.

| Engine variant | | Filling volume between MIN-MAX (litres) | Volume ¹ (litres) |
|----------------|----------|---|---------------------------------|
| 1.6 | B4164S3 | 0.75 | 4.0 |
| 1.8 | B4184S11 | | 4.3 |
| 1.8F | B4184S8 | | |
| 2.0 | B4204S3 | | |
| 1.6D | D4164T | 1.0 | 3.7 |
| 2.0D | D4204T | 2.0 | 5.5 |

¹Including filter change.

Engine oil

Oil decal



The following applies when this adjacent oil decal is fitted in the car's engine compartment. See location on page 220.

Oil grade: ACEA A5/B5

Viscosity: SAE 0W-30

| Engine variant | | Filling volume between MIN-MAX (litres) | Volume ¹ (litres) |
|----------------|----------------------|---|---------------------------------|
| D5 | D5244T8 | 1.5 | 6 |
| D5 | D5244T9 ² | | |

¹ Including filter change

² Belgium

 NOTE

Under normal driving conditions the gear-box oil does not need changing during its service life. However, it may be necessary under adverse driving conditions, see page 226.

11 Specifications

Fluids and lubricants

| Fluid | System | Volume | Recommended oil grade |
|----------------------|-----------------------------------|------------------------------|--|
| Gearbox oil | 1.6 Manual 5-speed | 2.1 litres | Transmission fluid: WSD-M2C200-C |
| | 1.8 Manual 5-speed | 1.9 litres | |
| | 1.6D Manual 5-speed | 1.9 litres | |
| | 1.8F Manual 5-speed | 1.9 litres | |
| | 2.0 Manual 5-speed | 1.9 litres | |
| | 2.0D Manual 5-speed | 2.2 litres | Transmission fluid: WSS-M2C200-C3 |
| | 2.0D Manual 6-speed | 1.7 litres | Transmission fluid: WSD-M2C200-C |
| | 2.4D Automatic gearbox | 7.75 litres | Transmission fluid: JWS 3309 |
| | D5 Automatic gearbox | 7.75 litres | Transmission fluid: JWS 3309 |
| | 2.4i Manual 5-speed | 2.1 litres | Transmission fluid: MTF 97309-10 |
| | 2.4i Automatic gearbox | 7.75 litres | Transmission fluid: JWS 3309 |
| | T5 Manual 6-speed | 2.0 litres | Transmission fluid: MTF 97309-10 |
| T5 Automatic gearbox | 7.75 litres | Transmission fluid: JWS 3309 | |
| Coolant | 5-cyl. Petrol, manual gearbox | 9.5 litres | Coolant with corrosion inhibitor mixed with water, see packaging. The thermostat starts opening at: 90 °C in petrol engines, and at 82 °C in diesel engines. petrol engine (1.6) 82 °C diesel engine (1.6D) 83 °C |
| | 5-cyl. Petrol, automatic gearbox | 10.0 litres | |
| | 5-cyl. Diesel (D5) | 11.0 litres | |
| | 4-cyl. Petrol (1.8, 1.8F and 2.0) | 7.5 litres | |
| | 4-cyl. Diesel (2.0D) | 9.5 litres | |
| | 4-cyl. Petrol (1.6) | 6.2 litres | |
| | 4-cyl. Diesel (1.6D) | 7.2 litres | |

Fluids and lubricants

| Fluid | System | Volume | Recommended oil grade |
|-------------------------------|-----------------------|----------------|---|
| Air conditioning ¹ | | 180–200 grams | Compressor oil PAG |
| | | 500–600 grams | Refrigerant R134a (HFC134a) |
| Brake fluid | | 0.6 litres | DOT 4+ |
| Power steering | | 0.8–0.9 litres | Power steering fluid: WSS M2C204-A2 or equivalent product with same specifications. |
| Washer fluid | 4-cyl. Petrol/Diesel | 4.0 litres | Use a washer antifreeze recommended by Volvo, mixed with water for temperatures below freezing. |
| | 5-cyl. Petrol /Diesel | 6.5 litres | |
| Fuel tank | See page 232. | | |

¹Weights can vary depending on the engine variant. Contact an authorised Volvo workshop for the correct information.

11 Specifications

Fuel

Consumption, emissions and volume

| Engine | Gearbox | Consumption litre/100 km | Emissions of CO ₂ (g/km) | Tank volume (litres) |
|--------------|-----------------------------|--------------------------|-------------------------------------|----------------------|
| 1.6 B4164S3 | Manual 5-speed (IB5) | 7.0 | 167 | 55 |
| 1.8 B4184S11 | Manual 5-speed (MTX75) | 7.3 | 174 | |
| 1.8F B4184S8 | Manual 5-speed (MTX75) | 7.3 | 174 | |
| 2.0 B4204S3 | Manual 5-speed (MTX75) | 7.3 | 174 | |
| 2.4i B5244S4 | Manual 5-speed (M56H) | 8.4 | 200 | 62 |
| | Automatic gearbox (AW55-51) | 9.0 | 214 | |
| T5 B5254T3 | Manual 6-speed (M66) | 8.7 | 208 | |
| | Automatic gearbox (AW55-51) | 9.4 | 224 | |

| Engine | Gearbox | Consumption litre/100 km | Emissions of CO ₂ (g/km) | Tank volume (litres) |
|--------------------------------|-----------------------------|--------------------------|-------------------------------------|----------------------|
| 1.6D D4164T (EURO3) (EURO4) | Manual 5-speed (MTX75) | 4.9 | 129 | 52 |
| 2.0D D4204T (EURO3) (EURO4) | Manual 6-speed (MMT6) | 5.7 | 151 | |
| D5 D5244T8 | Automatic gearbox (AW55-51) | 6.9 | 182 | 60 |
| D5 D5244T9 ¹ | Automatic gearbox (AW55-51) | | | |

¹Belgium

Fuel consumption and emissions of carbon dioxide

Official fuel consumption figures are based on a standard driving cycle in accordance with EU Directive 80/1268 comb. Fuel consumption figures may change if the car is equipped with extra equipment that affects the car's weight. The manner in which the car is driven, and other non-technical factors can also affect fuel consumption. Consumption is higher and power output lower for fuel with an octane rating of 91 RON.

Petrol

Most engines can be run with octane ratings of 91, 95 and 98 RON.

- 91 RON must not be used for 4-cylinder engines and should only be used in exceptional cases with other engines.
- 95 RON can be used for normal driving.
- 98 RON is recommended for optimum performance and minimum fuel consumption.

When driving in temperatures above +38 °C, fuel with the highest possible octane rating is recommended for optimum performance and fuel economy.

Petrol – Norm EN 228.



IMPORTANT

Use only unleaded petrol to avoid damaging the catalytic converter. In order for the Volvo warranty to apply, never mix alcohol with petrol, the fuel system could be damaged.

Diesel

The diesel engine's fuel system is sensitive to contaminants, see page 173.

Catalytic converter

General

The purpose of the catalytic converter is to purify exhaust gases. It is located in the flow of exhaust gases close to the engine so that it quickly reaches operating temperature. The catalytic converter consists of a monolith (ceramic or metal) with channels. The channel walls are lined with a thin layer of platinum, rhodium and palladium. These metals act as catalysts, i.e. they participate in and accelerate a chemical reaction without being used up themselves.

Lambda-sond™ oxygen sensor

The Lambda-sond is part of a control system intended to reduce emissions and improve fuel economy.

An oxygen sensor monitors the oxygen content of the exhaust gases leaving the engine. This value is fed into an electronic system that continuously controls the injectors. The ratio of fuel to air directed to the engine is continuously adjusted. Together with the three-way catalytic converter, these adjustments create optimal conditions for efficient combustion of the harmful emissions (hydrocarbons, carbon monoxide and nitrous oxides).

Electrical system

General

12 V system with a voltage-regulated alternator. Single pole system in which the chassis and engine block are used as conductors.

| Voltage | 12 V | 12 V | 12 V |
|---------------------------|---------|--------------------|--------------------|
| Cold start capacity (CCA) | 590 A | 600 A ¹ | 700 A ² |
| Reserve capacity (RC) | 100 min | 120 min | 135 min |
| Capacity (Ah) | 60 | 70 | 80 |

¹ Cars equipped with High Performance audio system.

² Cars equipped with diesel, keyless drive, audio system Premium Sound, fuel-driven heater or RTI.

If the battery is changed, replace it with a battery of the same cold start capacity and reserve capacity as the original (see the decal on the battery).

Certification of the Keyless Drive system

Siemens VDO Automotive A.G. hereby certifies that this equipment type 5WK4 8952, 5WK48956, 5WK48812 conforms to the essential characteristic requirements and other relevant regulations of directive 1999/5/EC.

Electrical system

Bulbs

| Lighting | Output W | Socket |
|---|----------|-----------|
| Dipped beam | 55 | H7 |
| Bi-Xenon | 35 | D2S |
| Main beam | 55 | HB3 |
| Brake lights, reversing lamps, rear fog lamp | 21 | BA15s |
| Direction indicators, rear/front (yellow) | 21 | BAU15s |
| Rear position/parking lamps, rear side marker lamps | 5 | BAY15d |
| Courtesy lighting, cargo area lighting, number plate lighting | 5 | SV8.5 |
| Vanity mirror | 1.2 | SV5.5 |
| Front position/parking lamps, front side marker lamps | 5 | W2.1x9.5d |
| Direction indicators in door mirrors (yellow) | 5 | W2.1x9.5d |
| Fog lamps | 55 | H11 |
| Glovebox lighting | 3 | BA9 |

Electrical system

Type approval, remote control system

| Country | |
|--|---|
| A, B, CY, CZ, D, DK, E, EST, F, FIN, GB, GR, H, I, IRL, L, LT, LV, M, NL, P, PL, S, SK, SLO | CE ¹ |
| IS, LI, N, CH | |
| HR | |
| ROK | Delphi 2003-07-15, Germany R-LPD1-03-0151 |
| BR |  ANATEL Agência Nacional de Defesa Industrial 0064-CG-2149 0107894476017753 |
| RC |  ETC093LPD0155 |

¹Delphi hereby certifies that this remote control system conforms to the essential characteristic requirements and other relevant regulations of directive 1999/5/EC.

A

| | |
|---|----------|
| <hr/> | |
| A/C | 70 |
| electronic climate control | 74 |
| manual climate control | 71 |
| ABS | 119 |
| ABS fault | 41 |
| Active Yaw Control | 121 |
| Additional heater | 77 |
| AF – automatic frequency update | 202 |
| Air conditioning | 70 |
| ECC | 72 |
| general | 68 |
| Air distribution | 75 |
| ECC | 74 |
| Air quality system, ECC | 73 |
| Air vents | 69 |
| Airbag | |
| deactivation | 20 |
| driver's and front passenger side | 16 |
| Alarm | |
| alarm lamp | 103 |
| alarm signals | 104 |
| arming | 103 |
| automatic alarm activation | 104 |
| deactivating a triggered alarm | 104 |
| disarming | 103 |
| general | 103 |
| testing the alarm system | 105 |
| Alarm, radio functions | 200 |
| Approach lighting | |
| active lamps | 61 |
| setting | 65 |
| Armrest | 86 |
| Audio volume | |
| audio system | 197 |
| media player | 197 |
| Audio, see also Sound | 197 |
| AUTO | |
| climate control settings | 72 |
| preset storage | 199 |
| AUTO CLIMATE | 72 |
| Auto volume control | 198 |
| Automatic car wash | 162 |
| Automatic dimming | 59 |
| Automatic gearbox | 116 |
| safety systems | 116 |
| towing and recovery | 128 |
| trailer | 131, 132 |
| W-button | 118 |
| Automatic locking | 100 |
| Automatic relocking | 100 |
| Autostart | 111 |
| Average fuel consumption | 49 |

B

| | |
|----------------------------|-----|
| <hr/> | |
| Backrest | |
| front seat, lowering | 80 |
| rear seat, lowering | 86 |
| Bass speaker | 197 |

Battery

| | |
|--|----------|
| care | 179 |
| jump starting | 130 |
| overload | 109 |
| replacement | 180 |
| replacing the battery in the | |
| remote control | 97 |
| symbols on the battery | 180 |
| Blind spot (BLIS) | 125 |
| Bonnet | 172 |
| Brake fluid, checking and topping up | 177 |
| Brake system | 119, 177 |
| Brakes | |
| handbrake | 56 |
| Bulb holder | |
| location of the bulbs | 184 |
| number plate lighting | 185 |
| removal | 184 |
| Bulbs | |
| replacement | 181 |
| specifications | 236 |

C

| | |
|--|-----|
| <hr/> | |
| Call | |
| functions during an ongoing call | 211 |
| phone volume | 210 |
| Call waiting | 209 |
| Calls | |
| making and receiving | 209 |
| Car care | |

| | | | | | |
|------------------------------------|----------|---|-----|-----------------------------------|----------|
| leather upholstery | 164 | Clean inside and out | 8 | Cruise control | 52 |
| Car settings | 64 | Cleaning | | D | |
| Car upholstery | 163 | automatic car wash | 162 | Deadlocks | 102 |
| Car wash | 162 | car wash | 162 | temporary deactivation | 102 |
| Cargo area | | seatbelts | 164 | temporary disconnection of alarm | |
| cargo cover | 87 | upholstery | 163 | detectors | 104 |
| lighting | 82 | Climate | | Defroster | 71 |
| load retaining eyelets | 90 | personal preferences | 64 | door mirrors | 71 |
| loading | 140 | Climate control | | rear window | 71 |
| safety net | 90 | general | 68 | Designation of dimensions | 144 |
| Cargo cover | 87 | Climate control settings | | Diesel | 173 |
| Catalytic converter | 234 | AUTO | 72 | engine preheater | 41 |
| recovery | 128 | Clock | 39 | Diesel filter | 173 |
| CD discs | | setting the clock | 39 | Diesel particle filter | 111 |
| storage compartment | 85 | Clutch fluid, checking and topping up | 177 | Dipped beam | 46, 48 |
| CD functions | 203 | Coat hanger | 85 | Direction indicators | 48 |
| Checks | | Collision | | Disc text | 204 |
| fluids and oils | 171, 174 | collision sensors | 23 | Display | |
| Child | | crash mode | 27 | messages | 43 |
| child seats and airbags | 28 | IC | 23 | Display lighting | 47 |
| Child seat | | inflatable curtain | 23 | Dolby Surround Pro Logic II | 196, 198 |
| fixture system | 31 | Colour code, paint | 165 | Door mirrors | 61 |
| installation | 31 | Combined instrument panel | 39 | Driver's door control panel | |
| Children | | Compass | 59 | operating | 57 |
| child seats and side airbags | 21 | calibration | 59 | overview | 38 |
| location in the car, table | 30 | Condensation | 173 | Driving | |
| safety equipment | 28 | Coolant, checking and topping up | 176 | adverse driving conditions | 170 |
| Cigarette lighter socket | | Cooling system | 108 | cooling system | 108 |
| front seat | 45 | Crash, see Collision | 23 | | |
| rear seat | 56 | | | | |

| | |
|---|-----|
| economical | 108 |
| slippery driving conditions | 108 |
| with open tailgate | 108 |
| with trailer | 131 |
| Driving in water | 108 |
| DSTC, see also Stability control system ... | 121 |
| DSTC, see also Stability system | |
| deactivating/activating | 121 |
| symbol | 41 |

E

| | |
|---------------------------------------|-----|
| Easy entry | 80 |
| ECC, electronic climate control | 69 |
| ECO pressure | |
| fuel economy | 148 |
| table | 149 |
| Economical driving | 108 |
| Electrical socket | |
| centre console | 45 |
| rear seat | 56 |
| Electronic immobiliser | 94 |
| Emergency calls | 207 |
| Emergency puncture repair | 153 |
| Emission control | 7 |
| Emissions | 232 |
| carbon dioxide | 233 |
| Emissions system | |
| fault indicator | 41 |
| Engine | 172 |

| | |
|-------------------------------------|---------------|
| Engine compartment | 172 |
| Engine oil | 174 |
| capacities | 227, 228, 229 |
| changing | 174 |
| driving under adverse driving | |
| conditions | 226 |
| filter | 174 |
| oil grade | 226 |
| oil pressure | 42 |
| Engine specifications | 224 |
| Entry, keyless | 65 |
| Environmental philosophy | 7 |
| EON – Enhanced Other Networks | 202 |
| Equalizer | 198 |
| Expectant mothers | |
| safety | 13 |

F

| | |
|--------------------------|----------|
| Fan | 70 |
| ECC | 72 |
| Fast-wind | 204 |
| First aid | 85 |
| Floor hatch | 89 |
| Floor mats | 81, 85 |
| Fluids and oils | |
| checks | 171, 174 |
| Fluids, capacities | 230 |
| Fog lamps | |
| on/off | 47, 49 |

| | |
|-----------------------------------|--------|
| Frequency update, automatic | 202 |
| Front seats | |
| easy entry | 80 |
| lowering | 80 |
| seating position | 80 |
| Fuel | |
| consumption | 7, 232 |
| fuel consumption, display | 49 |
| fuel economy | 148 |
| fuel filter | 173 |
| fuel system | 173 |
| level indicator | 41 |
| parking heater | 77 |
| refuelling | 110 |
| Fuel gauge | 39 |

Fuse table

| | |
|---------------------------------------|-----|
| fuses in the engine compartment | 189 |
| fuses in the passenger | |
| compartment | 192 |

Fuses

| | |
|---------------------------------|-----|
| general | 187 |
| relay/fuse box in the engine | |
| compartment | 188 |
| relay/fuse box in the passenger | |
| compartment | 191 |
| replacement | 187 |

G

Gearbox

| | |
|-----------------|-----|
| automatic | 116 |
| manual | 114 |

| | |
|----------------------------|-----|
| Glovebox | 85 |
| locking | 101 |
| Gross vehicle weight | 222 |

H

| | |
|-------------------------------|--------|
| Handbrake | 56 |
| Hazard warning flashers | 55 |
| Headlamp pattern | 141 |
| Headlamps | |
| headlamp washers | 50 |
| off/on | 46 |
| Heating | |
| front seats | 71, 74 |
| Home safe lighting | 48, 61 |
| Homesafe light duration | |
| setting | 65 |

I

| | |
|---------------------------|---------|
| IDIS | 207 |
| Ignition keys | 112 |
| IMEI number | 212 |
| Immobiliser | 94, 112 |
| "Important" texts | 6 |
| Incoming calls | 209 |
| Information display | 43 |
| Infotainment | |
| menus | 196 |
| Instrument lighting | 46, 47 |
| Instrument overview | |

| | |
|--------------------------------|---------|
| left-hand drive | 34, 206 |
| right-hand drive | 36 |
| Interior rearview mirror | 59 |
| Intermittent wiping | 50 |
| ISOFIX | |
| fixture system | 31 |

J

| | |
|---------------------|-----|
| Jump starting | 130 |
|---------------------|-----|

K

| | |
|--|-----|
| Kerb weight | 222 |
| Key | 94 |
| keyless lock and ignition system | 98 |
| remote control | 94 |
| Key blade | 95 |
| active locks | 96 |
| Keyless drive | 98 |
| starting the car | 113 |
| Keyless entry | 65 |
| Kick-down | |
| automatic gearbox | 116 |

L

| | |
|---------------------------------------|-----|
| Lambda-sond | 234 |
| Leather upholstery, washing | |
| instructions | 164 |
| Lighting | |
| automatic lighting, dipped beam | 46 |
| automatic lighting, passenger | |

| | |
|---------------------------------|--------|
| compartment | 83 |
| bulb replacement, general | 181 |
| bulbs, specifications | 236 |
| cargo area | 82 |
| dipped beam | 46 |
| display lighting | 47 |
| exterior | 46 |
| front fog lamps | 47, 49 |
| headlamp levelling | 46 |
| home safe lighting | 48, 61 |
| in passenger compartment | 82 |
| instrument lighting | 47 |
| lighting panel | 46 |
| main/dipped beam | 48 |
| position/parking lamps | 46 |
| reading lamps | 82 |
| rear fog lamp | 47 |

Lighting, bulb replacement

| | |
|-----------------------------------|-----|
| cargo area | 186 |
| courtesy lighting | 185 |
| dipped beam | 182 |
| direction indicators | 183 |
| fog lamp | 184 |
| front | 181 |
| location of the bulbs in the bulb | |
| holder | 184 |
| main beam | 182 |
| parking lamps | 183 |
| position lamps | 183 |
| rear lamp | 184 |
| reflector | 185 |

| | |
|--------------------------------------|-----|
| side marker lamps | 183 |
| vanity mirror | 186 |
| Lights | |
| main beam "flash" | 48 |
| Loading | |
| cargo area | 90 |
| general | 140 |
| load capacity | 140 |
| Lock settings, personal | 63 |
| Locking | 100 |
| from inside | 101 |
| from outside | 100 |
| unlocking | 100 |
| Lubricants, capacities | 230 |
| M | |
| Main beam | 48 |
| off/on | 46 |
| switching and flashing | 48 |
| Maintenance | |
| rustproofing | 166 |
| self-maintenance | 171 |
| Making calls | 209 |
| Manual gearbox | 114 |
| Menu structure | |
| media player | 205 |
| phone, menu options | 214 |
| phone, overview | 213 |
| Menus | |
| audio system | 196 |

| | |
|--|--------|
| Messages in the information display | 43 |
| Mirrors | |
| door | 61 |
| Misting | |
| attending to the windows | 68 |
| rear window | 71 |
| removing with defroster function | 71, 73 |
| timer function | 73 |
| timer function, A/C | 71 |

N

| | |
|-----------------------------|-----|
| NEWS | 201 |
| News broadcast | 201 |
| "Note" texts | 6 |

O

| | |
|--|-----|
| Oil, see also Engine oil | |
| oil pressure | 42 |
| Outside temperature gauge | 39 |
| Oxyhydrogen gas | 130 |

P

| | |
|--------------------------------------|--------|
| PACOS | 19 |
| Paint | |
| paintwork damage and touching up ... | 165 |
| Paintwork | |
| colour code | 165 |
| Parking assistance | 123 |
| sensors for parking assistance | 124 |
| Parking brake | 42, 56 |

| | |
|---|-----|
| Parking heater | |
| battery and fuel | 77 |
| general | 76 |
| parking on a hill | 76 |
| time setting | 77 |
| Parking lamps | 46 |
| Passenger compartment | |
| lighting | 82 |
| Passenger compartment filter | 68 |
| Personal preferences | 64 |
| approach lighting | 65 |
| auto blower adjust | 64 |
| automatic locking | 65 |
| doors unlock | 65 |
| homesafe light duration | 65 |
| keyless entry | 65 |
| lock confirm. light | 64 |
| recirculation timer | 64 |
| unlock confirm. light | 64 |
| Petrol grade | 233 |
| Phone | 208 |
| calling from the phone book | 211 |
| On/Off | 209 |
| standby mode | 209 |
| text input | 210 |
| Phone book | |
| handling numbers | 210 |
| Phone system | 206 |
| PI seek | 202 |
| Pinch protection, sunroof | 63 |

| | |
|--|-----|
| Polishing | 163 |
| Position lamps | 46 |
| Power seat | 81 |
| Power steering fluid, checking and topping up | 177 |
| Power windows | 57 |
| passenger seat | 58 |
| Programme functions | 200 |
| PTY – Programme type | 201 |
| Putting calls on hold | 209 |
| R | |
| Radio | |
| radio settings | 199 |
| radio stations | 199 |
| Radio text | 202 |
| Rain sensor | 51 |
| Random, CD and audio files | 204 |
| RDS functions | 200 |
| resetting | 202 |
| Reading lamps | 82 |
| Rearview mirrors | |
| compass | 59 |
| electrically retractable | 61 |
| interior | 59 |
| Recirculation | 70 |
| ECC | 73 |
| Recovery | 128 |
| Refrigerant | 68 |

| | |
|---|-----|
| Refuelling | |
| fuel cap | 110 |
| refuelling | 110 |
| Refuse calls | 209 |
| REG – Regional radio programmes | 202 |
| Relay/fuse box | |
| in the engine compartment | 188 |
| in the passenger compartment | 191 |
| Remote control | 94 |
| detachable key blade | 95 |
| functions | 94 |
| keyless drive | 98 |
| replacing the battery | 97 |
| Remote control system, type approval | 237 |
| Reverse gear inhibitor | |
| five-speed | 114 |
| six-speed, petrol | 115 |
| Rustproofing | 166 |
| S | |
| Safety | 12 |
| safety systems, table | 26 |
| Safety net | 90 |
| SCAN | |
| CD and audio files | 204 |
| radio stations | 200 |
| Seat | |
| key memory | 82 |
| power seat | 81 |
| Seatbelt | 12 |

| | |
|--|---------|
| pregnancy | 13 |
| rear seat | 13 |
| seatbelt tensioner | 14 |
| Seatbelt reminder | 13 |
| Seatbelt tensioner | 14 |
| Seats | |
| lowering the front backrest | 80 |
| manual setting | 80 |
| Service programme | 170 |
| Settings, see Personal preferences | 64 |
| Side airbags | 21 |
| SIM card | 207 |
| SIPS bags | 21 |
| SMS | |
| read | 212 |
| write | 212 |
| Soot filter | 43, 111 |
| SOOT FILTER FULL | 111 |
| Sound | |
| audio settings | 197 |
| audio source | 197 |
| Spare wheel | 150 |
| floor hatch | 89 |
| Speed dial | 211 |
| Speed dial numbers | 211 |
| Speed ratings, tyres | 144 |
| Speedometer | 39 |
| Spin Control | 121 |
| Spin control | 121 |

- SRS system
 general 17
 switch 20
 Stability control system 121
 Stability system
 indication 41
 Stains 163
 Standby mode, phone 209
 Standby, phone 209
 Starting from cold
 automatic gearbox 116
 Starting the engine 111
 keyless drive 113
 STC 121
 Steering lock 112
 Steering wheel
 cruise control 52
 keypad 208
 keypad left-hand side 52
 keypad right-hand side 54
 steering wheel adjustment 55
 Stone chips and scratches 165
 Storage compartment 84
 CD discs 85
 rear side panels 85
 Storage spaces in the passenger
 compartment 84
 Storing stations, manual and automatic ... 199
 Subwoofer 197
 Sunroof 62
 closing with remote control 63
 pinch protection 63
 sunscreen 63
 Sunscreen, sunroof 63
 Surround 196, 198
 Symbols 122
 indicator symbols 41
 warning symbols 40
- ## T
-
- Tachometer 39
 Tailgate
 driving with open tailgate 108
 locking/unlocking 94, 100
 Tank volume 232
 Temperature
 actual temperature 69
 passenger compartment,
 electronic climate control 74
 passenger compartment,
 manual climate control 71
 Temporary spare
 Temporary spare 146
 Ticket clip 85
 Timer
 A/C 71
 ECC 73
 Towbar, see Towing equipment 133
 Towing 128
 Towing equipment
 general 133
 installation 135
 removing 138
 specifications 134
 Towing eye 128
 TP – traffic information 200
 Traction control 121
 Traction control system 121
 Traffic information 200
 Trailer
 cable 133
 driving with a trailer 131
 trailer weight 222
 Trip computer 49
 Trip odometer 39
 Tuning 199
 Type approval, remote control system 237
 Type designation 220
 Tyre
 pressure 148
 Tyres
 designation of dimensions 144
 direction of rotation 147
 driving characteristics 144
 ECO pressure 149

- general 144
- puncture repair 153
- speed ratings 144
- summer and winter wheels 147
- tread wear indicators 145
- winter tyres 145

U

Unlocking

- from inside 101
- from outside 100
- keyless 100
- settings 64
- tailgate 100

V

- Vehicle data 170
- Ventilation 69
- Volume
 - auto volume control 198
 - phone/media player 210
 - programme types 202
- Volume, see also Audio volume 197

W

Warning lamp

- Stability and traction control system ... 121
- Warning symbol, AIRBAG system 15
- "Warning" texts 6
- Warning triangle 150

Washer

- rear window 51
- Washer fluid, topping up 176

Washers

- windscreen and headlamps 50
- Washing the car 162

Waxing 163

Wheels

- fitting 152
- removal 151
- rims 146

Whiplash injury WHIPS 24

- WHIPS 24
 - child seat/booster cushion 24

Windscreen wipers

- rain sensor 51
- Windscreen wipers and washer 50

Winter tyres 145

Wiper

- rear window 51

Wiper blades

- replacing, rear window 178
- replacing, windscreen 178

Volvo. for life

VOLVO

Volvo Car Corporation TP 8788 (EE English), AT 0637, Printed in Sweden, Göteborg 2006, Copyright © 2000-2006 Volvo Car Corporation

Download from [Www.Somanuals.com](http://www.somanuals.com). All Manuals Search And Download.

Free Manuals Download Website

<http://myh66.com>

<http://usermanuals.us>

<http://www.somanuals.com>

<http://www.4manuals.cc>

<http://www.manual-lib.com>

<http://www.404manual.com>

<http://www.luxmanual.com>

<http://aubethermostatmanual.com>

Golf course search by state

<http://golfingnear.com>

Email search by domain

<http://emailbydomain.com>

Auto manuals search

<http://auto.somanuals.com>

TV manuals search

<http://tv.somanuals.com>