

# WEIL-McLAIN

## Boiler Manual

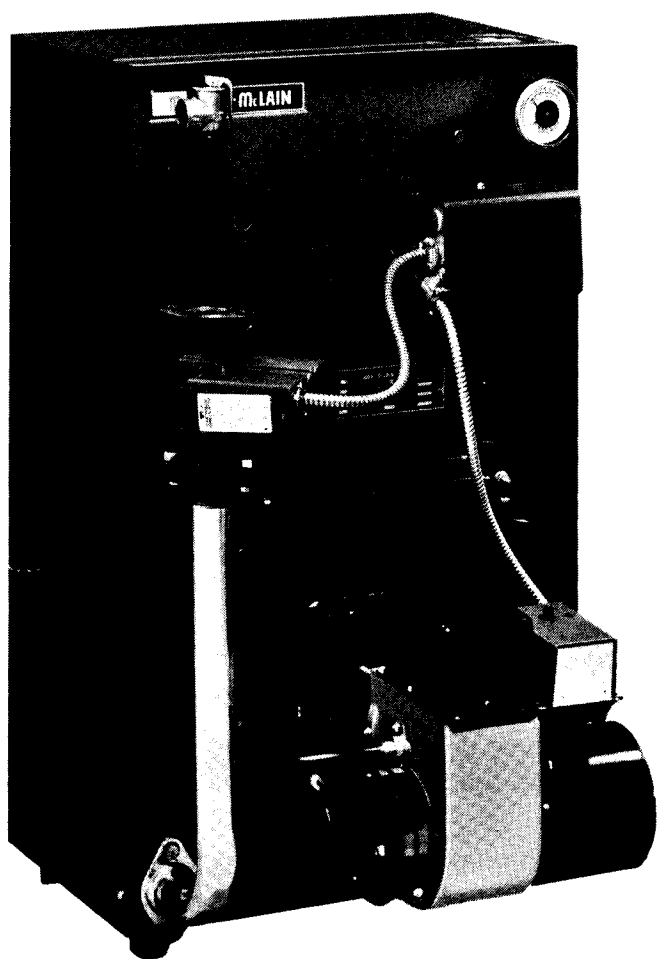

### MODELS P-66HE, B-66HE AND A-66E (Series 3) OIL-FIRED BOILERS

- To the installer:** Installation is not complete until all instructions shipped with this boiler are returned to their envelope and displayed near the boiler.
- To the owner:** Regular service on this boiler is recommended and should be performed by a qualified heating contractor.

**Read all instructions and warranty before starting**

Any claims for damage or shortage in shipment must be filed immediately against the transportation company by the consignee.

Part No. 550-110-440/0584WP

# INSTALLATION OUTLINE and TABLE OF CONTENTS

## Section I: Pre-Installation Considerations

	Page
Air supply .....	3
Clearances .....	3
Foundation .....	3

## Section II: Locating the Boiler

	Page
Placement .....	4
Hydrostatic test .....	4
Jacket assembly .....	4

## Section III: Piping to the System

Water piping connections .....	4
Multiple zoning-circulators .....	4
Multiple zoning-zone valves .....	4
Freeze protection .....	4
By-pass piping .....	5
Low Water cut-off .....	5
ASME approval .....	5
Relief valve piping .....	5
Expansion tank and air vent .....	5
Minimum pipe sizes .....	5
Piping schematic .....	5
Steam piping connections .....	6
Equalizer .....	6
Relief valve piping .....	6
Minimum pipe sizes .....	6
Piping schematic .....	6
Replacement steam boiler piping for one-pipe systems .....	6

## Section IV: Tankless & Storage Heater Hook-up

	Page
Tankless heaters—water boilers .....	7
Tankless heaters—steam boilers .....	7
Storage heaters—water boilers only .....	7

## Section V: Non-packaged Boilers—Controls & Burner

	Page
Tapping table .....	8
Water boiler controls .....	8
Steam boiler controls .....	8
Oil burner .....	9

## Section VI: Chimney & Breeching

	Page
Chimney or vent requirements .....	9
Breeching erection .....	9
Barometric draft control .....	9

## Section VII: Wiring & Fuel Line Piping

	Page
Wiring .....	10
Fuel line piping .....	10

## Section VIII: Final Adjustments

	Page
Fill the system .....	10
Burner adjustment (use combustion test equipment) .....	10
Skimming steam boilers .....	10

## Section IX: Check-out Procedure Page 11

## Section X: Dimensions Page 11

## Section XI: Ratings Page 12

**READ ALL INSTRUCTIONS *BEFORE* STARTING**  
**FAILURE TO COMPLY WITH INSTALLATION INSTRUCTIONS CAN VOID WARRANTY**

**IMPORTANT: When calling or writing about the boiler, PLEASE GIVE THE MODEL, SERIES, AND C.P. NUMBERS located on the boiler rating nameplate. Any reuse or reproduction of the artwork and copy in this**

**manual is strictly prohibited without the written consent of Weil-McLain. ORDER BURNER PARTS DIRECTLY FROM BURNER MANUFACTURER.**

The following terms are used throughout this manual to bring attention to the presence of hazards of various risk levels, or to important information concerning the life of the product. An explanation of each term is given below.

**DANGER**

Danger is used to indicate the presence of a hazard which *will* cause *severe* personal injury, death or substantial property damage if the warning is ignored.

**CAUTION**

Caution is used to indicate the presence of a hazard which *will* or *can* cause *minor* personal injury or property damage if the warning is ignored.

**WARNING**

Warning is used to indicate the presence of a hazard which *can* cause *severe* personal injury, death or substantial property damage if the warning is ignored.

**NOTICE**

Notice is used to notify of special instructions on installation, operation or maintenance which are important but not related to personal injury hazards.

## Section I: Pre-Installation

Installations must comply with all local codes, laws, regulations and ordinances. When required, the installations must conform to American Society of Mechanical Engineers Safety Devices for Automatically Fired Boilers, No. CSD-1.

In Canada the installation must comply with Canadian Standards Association CSA B149, Installation Code for Oil Burning Equipment, and any local or provincial codes that may apply.

### AIR SUPPLY FOR COMBUSTION

**WARNING**

Adequate combustion and ventilation air must be provided to assure proper combustion.  
**AN EXHAUST FAN MUST NOT BE USED IN THE BOILER ROOM AREA.**

1. Conventional buildings—unconfined rooms:
  - a) Infiltration will normally provide enough air.
2. Confined room OR boiler room without an outside wall:
  - a) A fresh air opening to the outside must be provided.
    - 1) Free cross sectional area must be at least 1 square inch per 7,000 BTUH burner firing rate.
3. For each 1,000 feet above sea level:
  - a) Increase fresh air opening by 4 percent.

### SELECT THE BOILER LOCATION

CONSIDER ALL CONNECTIONS TO THE BOILER BEFORE SELECTING A LOCATION.

**WARNING**

To avoid personal injury, death or property damage, keep the boiler area clear and free from combustible materials, gasoline and other flammable vapors and liquids.

### MINIMUM CLEARANCES

- 24 inches—front and top
- 6 inches—Flue pipe to combustible materials.
- 6 inches—Right and left sides (except steam with tankless heater)
- 15 inches—Left side for steam with tankless heater.

### RESIDENTIAL GARAGE INSTALLATION

**WARNING**

Install boiler so burner is at least 18 inches above the floor. In Canada refer to CSA B149 codes.

### BOILER FOUNDATION

Boiler may be installed on non-carpeted combustible flooring. Boiler legs provide approximately one inch air space for natural aeration.

If a boiler foundation is necessary, it should be constructed according to the chart and Figure 1. These dimensions allow about one inch clearance around the boiler.

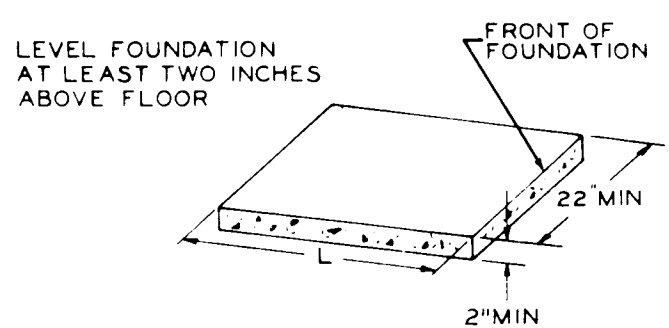

**FIGURE 1**

<b>BOILER FOUNDATION SIZES</b>		
<b>L = Length of Foundation</b>		
<b>Boiler Size</b>	<b>Packaged Water Only</b>	<b>All Other Boilers</b>
266	12½"	—
366	15½"	15½"
466	15½"	18½"
566	18½"	21½"
666	21½"	24½"
766	24½"	27½"

## Section II: Locating the Boiler

### PLACEMENT

Position boiler close to the chimney. Provide minimum clearances as indicated.

#### NOTICE

When transporting with crate removed, do not tip boiler forward. Damage to the burner may result.

### HYDROSTATIC PRESSURE TEST

Pressure test BEFORE attaching piping or electrical supply. Install, but do not hook up, tankless heater (if used).

1. Remove shipping nipple.
2. Install a drain at a low point in the boiler.
3. Install a valve at the highest tapping to vent air.
4. Connect water supply.
5. Plug, cap or use blind flanges on all remaining tappings or openings, including compression tank tapping.
6. Fill boiler with water. Completely purge all air. Test at one and one-half times boiler working pressure or 45 PSI, whichever is greater. Test for at least 10 minutes.

#### WARNING

DO NOT LEAVE BOILER UNATTENDED. Cold fill water could expand and cause excessive pressure.

7. Thoroughly inspect entire boiler, including tankless heater (if used), for leaks. Confirm test pressure has remained constant.
8. Leaks must be repaired at once to prevent continual use of fresh make-up water. Minerals and oxygen in fresh water will seriously reduce boiler life.

#### NOTICE

DO NOT USE PETROLEUM BASED STOP-LEAK COMPOUNDS. Leakage between boiler sections will occur.

9. Drain boiler and remove testing plugs.
10. On initial start-up, check for leaks in system piping. If found, repair at once.

### JACKET ASSEMBLY (For non-packaged boilers)

Refer to jacket erecting instructions packed in the jacket carton.

1. All unused tappings must be plugged.
2. Following parts may be on the boiler.
  - Draft hood collar
  - System supply piping
  - System return piping (front section only)
  - Drain cock
  - Compression tank piping
  - Steam safety valve
3. Following parts must be off the boiler.
  - Combination pressure-temperature-altitude gauge or steam trim
  - Relief valve
  - Gauge glass cocks and gauge glass
  - Indirect water heater piping and operating control
  - Try cocks (if required)
  - System return piping (rear section only)

## Section III: Piping to the System

#### CAUTION

Failure to properly pipe boiler may result in improper operation and damage to boiler or building.

### WATER BOILER PIPING CONNECTIONS TO THE SYSTEM (Refer to Piping Diagrams, Page 5)

1. For multiple zoning with circulators, these changes must be made:
  - a) Size each circulator to individual circuit requirements.
  - b) Remove circulator and preformed pipe (when furnished as standard equipment).
  - c) From 1½" N.P.T. tapped return inlet at front of boiler, construct a pipe manifold according to the number of circulators used.
  - d) Install circulators.
  - e) Install flow control valves to prevent gravity circulation.
  - f) Install balancing valves to adjust the flow so it is about the same in each zone.
  - g) Separate relays (Honeywell R845A, White-Rodgers 829A-845, or equivalent) are required for each additional circulator.
2. For multiple zoning with zone valves, install balancing valves to adjust the flow so it is about the same in each zone. A separate transformer may be required to power zone valves. Refer to zone valve manufacturer's instructions.
3. Consider the installation of additional equipment:

- a) By-pass piping should be used for low water temperature applications (i.e. radiant panel systems, converted gravity systems, etc). By-pass, supply and return piping should all be the same size. See Figure 2. Adjust valves to maintain boiler temperatures greater than 160°F.

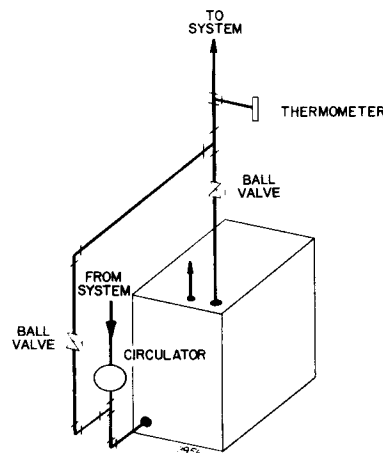

FIGURE 2  
BY-PASS PIPING ARRANGEMENT

**b) Low water cut-off:**

- i) Should be installed if boiler is located above radiation level.
- ii) May be required on water boilers by certain state, local or territorial codes or by insurance companies.

Use a low water cut-off designed for water installations. An electrode probe type is recommended. Install in a tee in supply line above boiler.

**c) Freeze protection (when used):**

- i) Use antifreeze especially made for hydronic systems. Inhibited propylene glycol is recommended. DO NOT use automotive type antifreeze.
- ii) 50% solution provides maximum protection to about -30°F.
- iii) Local codes may require a back-flow preventer or actual disconnect from city water supply.
- iv) Determine quantity according to system water content. Boiler water content is listed on page 12. Percent solution will affect sizing of HEAT DISTRIBUTING UNITS, CIRCULATOR AND EXPANSION TANK.
- v) Follow antifreeze manufacturer's instructions.

**d) If the system is to comply with ASME codes, an additional high temperature limit is needed. Purchase and install in supply piping from the boiler.**

**4. WARNING** Relief valve discharge piping must be piped near to the floor or to a floor drain to eliminate potential of severe burns. Do not pipe where freezing could occur.

**5. Expansion tank and air vent:**

- a) Size expansion tank to design requirements of system.
- b) **Closed diaphragm pre-pressurized tank**—may be located anywhere in the system, preferably near the boiler.

**NOTICE**

A manual or automatic air vent must be installed with this type of tank. Install in 3/4" tapping as shown in Figure 3.

- c) **Closed type tank**—connect from 3/4" tapping to the expansion tank. Use 3/4" pipe. Any horizontal piping must pitch upward 1 inch for each 5 feet of piping. See Figure 4.

6. Connect supply, return and cold water fill piping.

**\*WATER BOILER PIPING  
RECOMMENDED MINIMUM PIPE SIZES**

Boiler Size	Supply Pipe Size "A"	Return Pipe Size "B"	Piping to Compression Tank "C"
266W	1 1/4" N.P.T.	1" N.P.T.	3/4" N.P.T.
366W and 466W	1 1/4" N.P.T.	1 1/4" N.P.T.	3/4" N.P.T.
566W thru 766W	1 1/2" N.P.T.	1 1/2" N.P.T.	3/4" N.P.T.

Recommended minimum pipe size with 20°F temperature rise through the boiler.

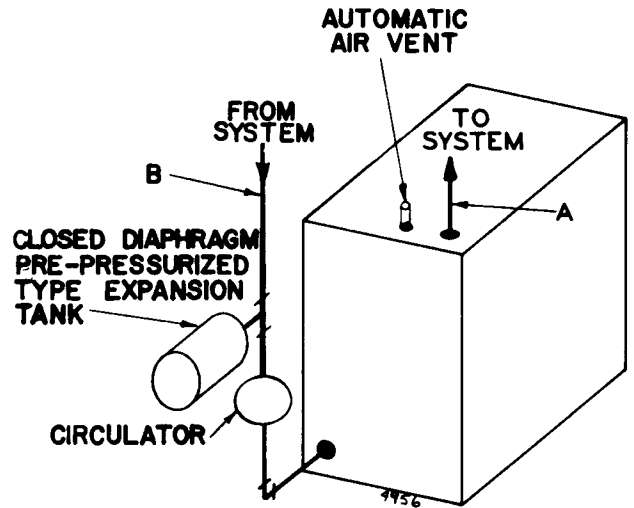

**FIGURE 3  
RECOMMENDED PIPING CONNECTIONS  
FOR WATER BOILERS WITH CLOSED  
DIAPHRAGM PRE-PRESSURIZED TANK**

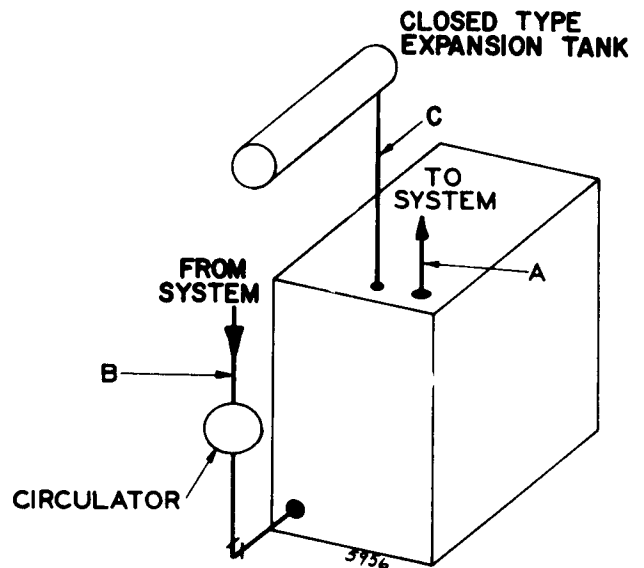

**FIGURE 4  
RECOMMENDED PIPING CONNECTIONS  
FOR WATER BOILERS WITH  
CLOSED-TYPE EXPANSION TANK**

## STEAM BOILER PIPING CONNECTIONS TO THE SYSTEM

(For Replacement Boilers on One-Pipe Systems, See Next Section)

### CAUTION

Failure to properly pipe the boiler may result in improper operation and damage to the boiler or building.

1. Connect the steam supply riser, header, and equalizer. Bottom of the supply header should be at least 24 inches above boiler water line.
  - a. Connect system supply piping to the header.
  - b. Connect condensate return piping to the equalizer piping 2 inches below boiler water line.
2. Connect cold water fill supply piping close to boiler in the condensate return piping.

### WARNING

Relief valve discharge piping must be piped near to the floor or to a floor drain to eliminate potential of severe burns. Do not pipe where freezing could occur.

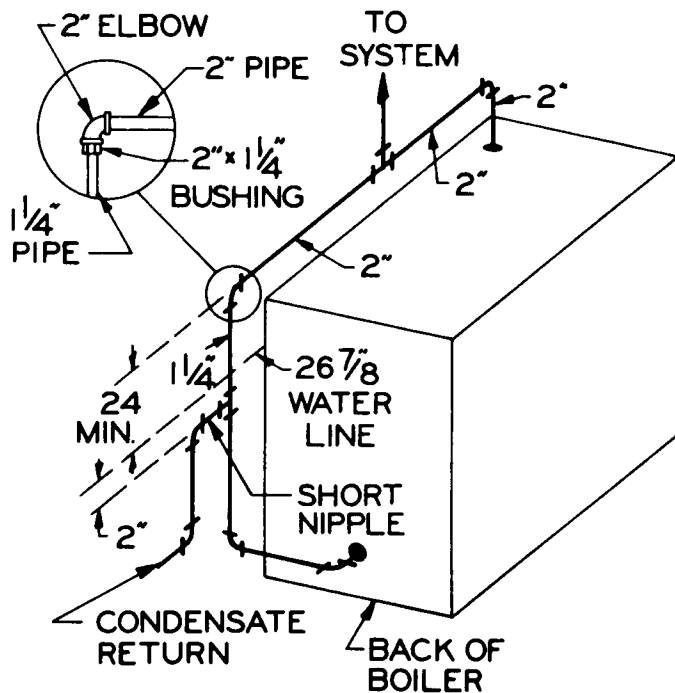

FIGURE 5  
RECOMMENDED PIPING CONNECTIONS FOR STEAM BOILERS

\*STEAM BOILER PIPING  
MINIMUM RECOMMENDED PIPE SIZES  
(For Replacement Boilers, See Next Section)

Boiler Size	Supply Pipe Size	Header Pipe Size	Equalizer Pipe Size
366S thru 766S	2"	2"	1 1/4"

\*24" minimum from water line to the bottom of header.

## REPLACEMENT BOILER CONNECTIONS ONE-PIPE STEAM SYSTEMS

Recommended piping for replacement boilers on older one-pipe steam systems is shown below. The short length of riser from the boiler will not have condensate flowing against the steamflow. If the water droplets should be thrown from the boiler, they will be separated in the large header and immediately returned to the boiler through the equalizer. The pressure drop through the short riser from the boiler is not significant.

Some installations may require an added water tank for additional steaming capacity. By installing two plugged tees as shown in Figure 6, a tank can easily be added if necessary. The tank provides water volume at the steaming surface so burner cycling, added make-up water and flooding, caused by slow condensate return, will be reduced or eliminated. Obtain Bulletin AE-8403 from your Weil-McLain distributor for tank sizing.

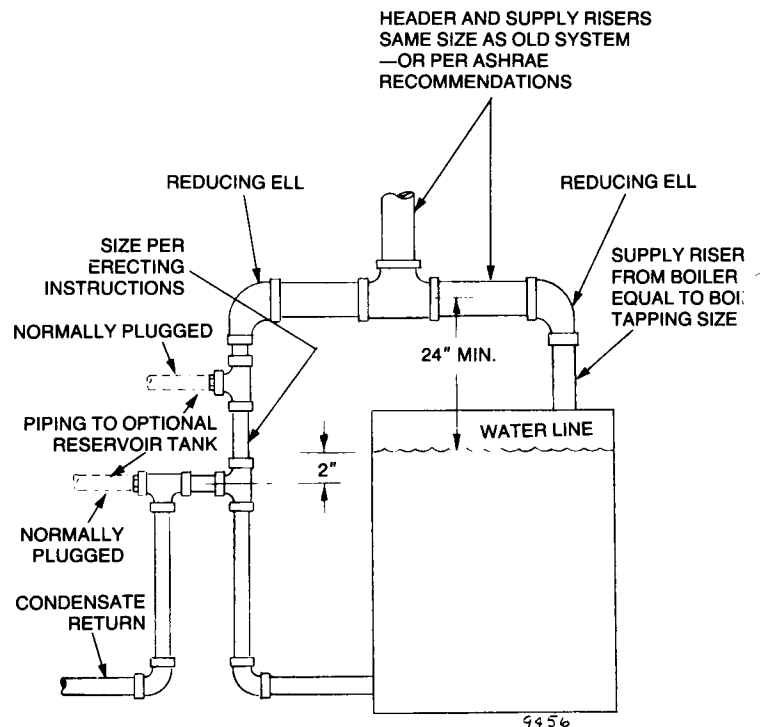

NOTE:  
SWING JOINTS NOT SHOWN

FIGURE 6  
RECOMMENDED PIPING FOR REPLACEMENT STEAM BOILERS—ONE-PIPE SYSTEMS

# Section IV: Tankless & Storage Heater Hook-up

## TANKLESS HEATER HOOK-UP

Install as shown in Figure 7 (water boilers) or Figure 8 (steam boilers). No. 266 cannot use a tankless heater.

1. Install automatic mixing valve.
2. Install flow regulating valve. Size according to intermittent draw of heater as shown in table.
3. Operating control with a small differential scale is recommended. Install in temperature control tapping in heater plate.
4. In hard water areas, it is advisable to soften the cold domestic supply water to the tankless heater to prevent lime build-up.

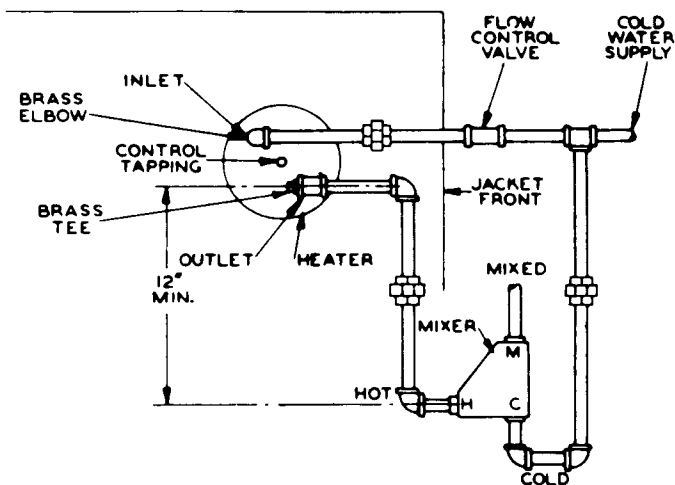

Note: Piping connections not furnished. Use brass plugs in tees and crosses to facilitate cleaning in hard water areas.

FIGURE 7  
TANKLESS HEATER PIPING (WATER BOILER)

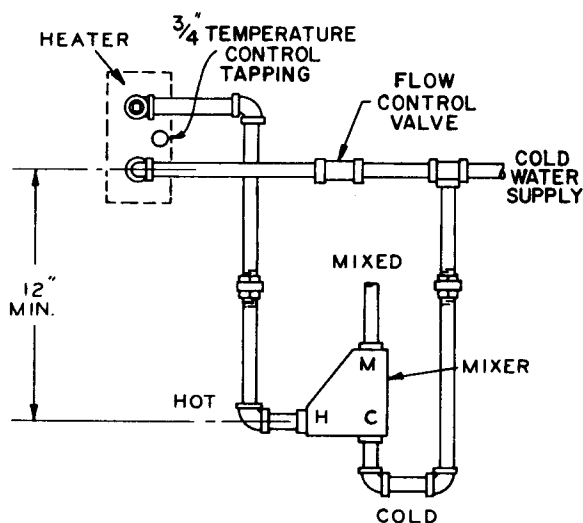

Note: Piping connections not furnished. Use brass plugs in tees and crosses to facilitate cleaning in hard water areas.

FIGURE 8  
TANKLESS HEATER PIPING (STEAM BOILER)

## NO. 66 STEAM AND FORCED HOT WATER BOILER TANKLESS HEATER RATINGS

Boiler Size	Heater No.	*Intermittent Draw GPM 100°F. Average Temp. Rise	**Continuous Draw GPM 100°F. Temp. Rise	Inlet and Outlet Tappings	Temp. Control Tapping
<b>WATER</b>					
366	E-624	3.00	2.00	1/2"	3/4"
466	E-624	3.25	2.70	1/2"	3/4"
566	E-624	3.25	3.30	1/2"	3/4"
666	E-626	3.50	4.00	1/2"	3/4"
766	E-632	4.25	4.60	1/2"	3/4"
<b>STEAM</b>					
366	35-S-29	3.00	2.00	3/4"	3/4"
466	35-S-29	3.25	2.70	3/4"	3/4"
566	35-S-29	3.50	3.30	3/4"	3/4"
666	35-S-29	3.75	4.00	3/4"	3/4"
766	35-S-29	4.00	4.60	3/4"	3/4"

Weil-McLain ratings based on 60 PSIG domestic water pressure at heater.

\* Gallons of water per minute heated from 40° to 140°F. with 200°F. boiler water temperature.

\*\* Continuous draw—no recovery period.

■ Not available on 266HE boilers.

## STORAGE HEATER HOOK-UP (forced hot water boiler only)

### NOTICE

The 62-2-E Storage Heater cannot be used with No. 266 thru 566 forced hot water boilers or any size steam boiler.

1. Locate tank as high as possible above boiler.
2. Vertical type storage tank can be used if bottom of tank can be located above top of boiler.
3. To provide gravity circulation:
  - a) Horizontal supply from heater to tank must pitch upward 1 inch for each 10 feet of piping.
  - b) Horizontal return from tank to heater must pitch downward 1 inch for each 10 feet of piping.
4. Locate return piping above storage heater.
5. Use as few elbows and pipe fittings as possible.

## STORAGE HEATER RATINGS

Boiler Size*	Storage Heater Number	180° Boiler Water Heater Capacity Gallons	212° Boiler Water Heater Capacity Gallons
		40°-140° Rise	40°-140° Rise
666-766	62-2-E	50 in 3 Hours	70 in 3 Hours
Recommended Storage Tank		50-90 Gallons	75-125 Gallons

\*No. 62-2-E storage heater cannot be used with 266 through 566 water boilers or with any steam boilers.

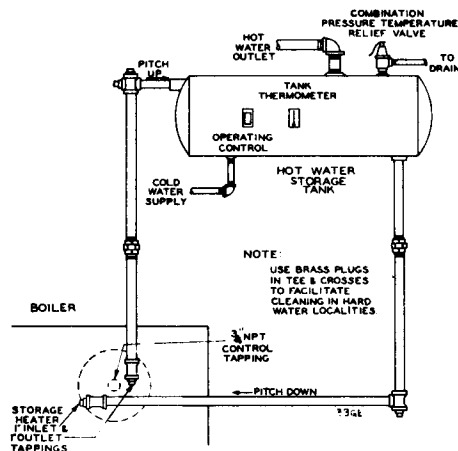

FIGURE 9  
STORAGE HEATER PIPING

# Section V: Non-packaged Boilers—Control & Burner Installation

## INSTALL BOILER CONTROLS (non-packaged boilers)

### WARNING

Failure to properly install, pipe and wire boiler controls may result in severe damage to the boiler, building and personnel, and will void the boiler warranty.

Use a low water cut-off designed for water installations. An electrode probe type is recommended. Locate in a tee in supply line above boiler.

- If the system is to comply with ASME codes, an additional high temperature limit is needed. Purchase and install in supply piping from boiler.

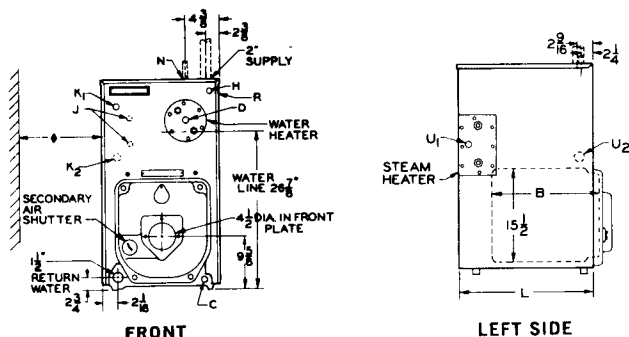

◆ 15" minimum heater clearance.

**FIGURE 10  
TAPPINGS**

LOCATION	SIZE	WATER	STEAM
C	3/4"	Drain	Drain
D (in plate)	1 1/2"	High-Limit Control (bushed to 3/4")	Skim Tapping
D (in water heater)	3/4"	Combination High-Limit and Operating Control	—
H	1/4"	Combination Pressure and Temperature Gauge	Pressure Gauge and Pressure Limit Control
J*	3/8"	—	Try Cock Tappings
K <sub>1</sub>	3/4"	Pressure Relief Valve	Gauge Glass and/or Low- Water Cutoff (bushed to 1/2")
K <sub>2</sub>	3/4"	Plugged	Gauge Glass and/or Low- Water Cutoff (bushed to 1/2")
N	3/4"	To Compression Tank	Safety Valve
R*	3/4"	Limit Control	Limit Control
U <sub>1</sub> (in steam heater)	3/4"	—	Heater Operating Control (366E through 566E Boilers)
U <sub>1</sub>	3/4"	Plugged	Heater Operating Control (666 and 766 Boilers)

\*Available only on special request.

## WATER BOILER CONTROLS (non-packaged boilers)

- Install controls where shown on tapping table.

### WARNING

Relief valve discharge piping must be piped near to the floor or to a floor drain to eliminate potential of severe burns. Do not pipe where freezing could occur.

- Low water cut off for water boilers:**

- Should be installed if boiler is located above radiation level.
- May be required on water boilers by certain state, local or territorial codes or insurance companies.

## STEAM BOILER CONTROLS (non-packaged boilers)

- Connect a low water cut-off to gauge glass tappings K1 and K2. Refer to Figure 11. Follow instructions packed with the control. Pipe drain near the floor or floor drain.
- Install the pigtail syphon, pressure gauge and steam pressure limit control. See Figure 11.

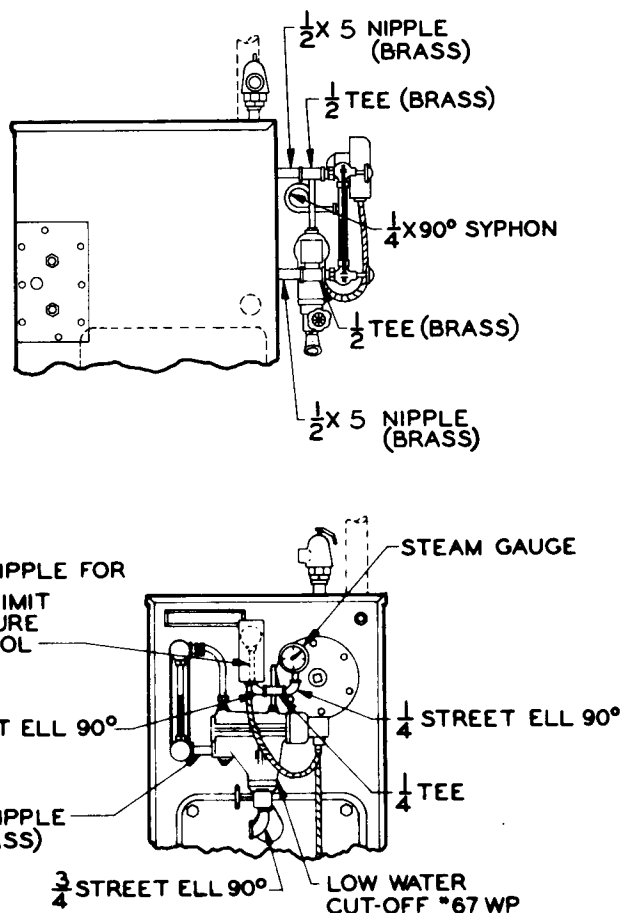

**FIGURE 11  
STEAM CONTROLS**

### WARNING

Relief valve discharge piping must be piped near to the floor or to a floor drain to eliminate potential of severe burns. Do not pipe where freezing could occur.



## INSTALL OIL BURNER (non-packaged boilers)

For B-66HE boiler:

1. Place gasket over end of air tube.
2. Loosely screw three mounting bolts into boiler mounting plate.
3. Mount burner.
4. Tighten mounting bolts.

For A-66E boiler (see Figure 12):

1. Secure universal mounting flange and gasket to burner mounting plate. Use three bolts provided.
2. Position burner so it is level to  $1\frac{1}{2}^\circ$  tilt downward. Air tube should be flush to  $\frac{1}{4}$  inch recessed from inside wall of combustion chamber.
3. Clamp mounting flange to burner using screws provided.

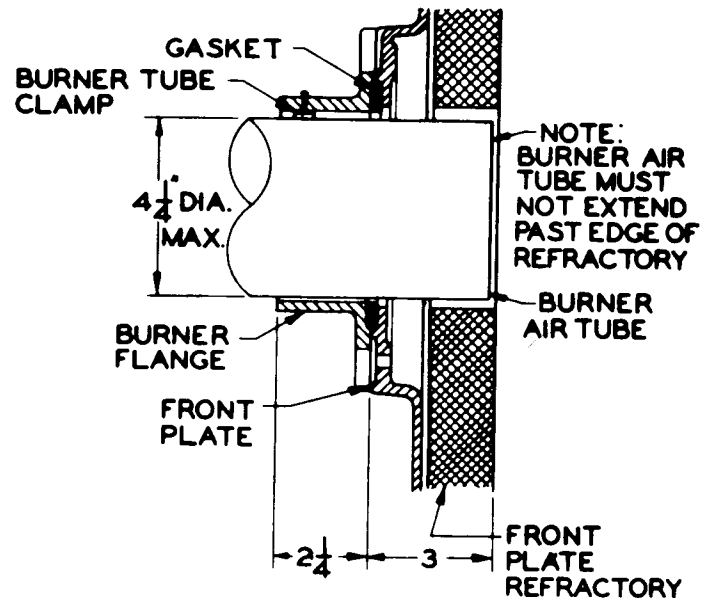

FIGURE 12  
MOUNTING OIL BURNER

## Section VI: Chimney & Breeching

### CHIMNEY OR VENT REQUIREMENTS

Designed for NATURAL DRAFT FIRING ONLY. Use a Class A chimney.

Minimum chimney or vent sizes are on page 12 of these instructions. In most cases a chimney or vent extended at least 3 feet above the highest part of the roof or other structure within 30 feet will be sufficient to prevent downdrafts. Increase chimney cross-sectional area and height at least 4 percent for each 1,000 feet above sea level.

Examine the chimney for proper construction and possible blockage.

An induced draft fan may be necessary if:

- 1) Excessive resistance to flow of combustion gases can be expected.
- 2) Cross-section area of chimney is smaller than minimum recommended.
- 3) Chimney height is less than recommended.

If an induced draft fan is used, overfire draft should not exceed.  $-.02$  water column.

### BREECHING ERECTION

Use full-sized breeching (P-266HE breeching may be reduced to 5 inches). Slope upward at least  $\frac{1}{4}$  inch per lineal foot toward the chimney or vent.

Connection must be above bottom of chimney to avoid blockage. Breeching must not enter chimney far enough to cause obstruction. Use a thimble or slip joint where breeching enters the chimney to allow removal for cleaning.

Avoid long horizontal runs, excessive numbers of elbows or tees, or other obstructions that would restrict the flow of combustion gases.

### BAROMETRIC DRAFT CONTROL

Install pipe or elbow as shown in Figure 13. Install barometric draft control in breeching 18 to 20 inches from collar between boiler and chimney. Drill a small hole in breeching just ahead of the boiler smoke collar for measuring  $CO_2$ , breeching draft and smoke.

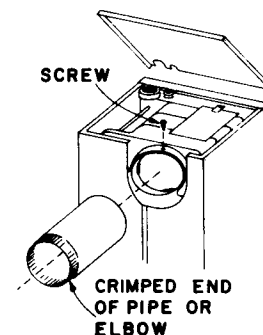

FIGURE 13  
BREECHING CONNECTION

## Section VII: Wiring & Fuel Line Piping

Sec. VII

### WIRING

#### WARNING

For your safety, turn off electrical power supply at service entrance panel before making any electrical connections to avoid possible electrical shock hazard.

Wiring must be installed in accordance with the requirements of the National Electrical Code and any additional national, state, or local codes.

In Canada the installation must conform to Canadian Electrical Code, Part 1, C22.1, Safety Standard for Electrical Installations, and any provincial or local codes.

All safety circuit wiring must be N.E.C. Class 1.

If any additional electrical safety controls are employed, use No. 14 gauge wire. Power input supply wiring to the burner should be No. 14 gauge wire or heavier and should have a properly sized fused disconnect switch. Be sure boiler is properly grounded at switch box.

### FUEL LINE PIPING

Refer to separate burner manual and any local or national code requirements which may apply to sizing and installing the fuel line piping.

A two-pipe system with copper tubing and flared fittings is recommended.

## Section VIII: Final Adjustments

### FILL THE SYSTEM

#### Water boilers:

1. Fill to correct system pressure (typically 12# for residential systems).
2. Follow burner adjustment procedure below.
3. Check system piping for leaks. Repair at once to prevent continual use of fresh make-up water. Minerals and oxygen in fresh water will seriously reduce boiler life.

#### NOTICE

Do not use petroleum based stop-leak compounds or leakage between the boiler sections will occur.

4. Vent all air from the system.

#### Steam boilers:

1. Fill to normal waterline (halfway up gauge glass).
2. Follow burner adjustment procedure below.
3. Check system piping for leaks. Repair at once to prevent continual use of fresh make-up water. Minerals and oxygen in fresh water will seriously reduce boiler life.

#### NOTICE

Do not use petroleum based stop-leak compounds or leakage between the boiler sections will occur.

4. Skim boiler as outlined below.

### BURNER ADJUSTMENT

#### CAUTION

Final burner adjustments must be made using combustion test equipment to assure proper operation. **DO NOT FIRE BOILER WITHOUT WATER OR SECTIONS WILL OVERHEAT.**

1. Refer to burner manual for start-up. Adjust air band to provide a clean yellow flame without smokey tips.
2. Allow boilers to heat to design conditions.
3. Using combustion test equipment, adjust burner for:
  - a) 12% ( $\pm 1/4\%$ ) CO<sub>2</sub>
  - b) 0 smoke
  - c) -0.02 negative draft overfire

### SKIMMING STEAM BOILERS (steam systems only)

#### CAUTION

Skim all newly installed steam boilers to remove oil, grease, chips and other foreign material. **DO NOT** clean old piping or leaks can open up in the system.

Failure to skim can result in violent fluctuations of the water level, water passing onto the steam mains, or high maintenance costs on strainers, traps or vents.

In some cases, skimming will not completely clean the boiler. If necessary, the boiler can be flushed with trisodium phosphate (or sodium carbonate or sodium hydroxide) mixed with water. Fire, allow to soak, completely drain and refill.

Boiler water pH of 7.5 to 8.5 is recommended.

1. Provide a full sized skim line with valve from boiler skim tapping to a convenient floor drain.
2. Fire boiler at a temperature just below steaming rate during the skimming process.
3. Skim top of water through skim line to the drain. Keep waterline at a level to allow top layer of water to slowly discharge through skim line.
4. Feed water to boiler to maintain proper water level. It may be necessary to cycle burner to prevent a rise in steam pressure.
5. Continue skimming until discharge is clear. This may take several hours. Occasionally the procedure may require repeating one or more times.
6. Drain boiler and, while boiler is warm but **NOT HOT**, remove safety valve and insert a hose nozzle into the opening. Flush all interior surfaces of boiler with water under full pressure until all traces of dirt and impurities are removed and drain water runs clear.
7. Replace safety valve. Close drain cock. Fill with fresh water to the waterline. Start burner and steam for 15 minutes to remove all dissolved gases. Stop burner.
8. Drain boiler sufficiently to remove skim piping. Plug skim tapping. Refill boiler to waterline.
9. To prevent return of impurities to the boiler from old piping systems, it may be necessary to install a strainer in the condensate return piping. In addition, it may be necessary to waste all condensate for several days or until no impurities are contained in the condensate.
10. Make sure all traps and air vents are operative and in good condition to allow for proper steam distribution.

**NOTE—FEEDWATER MUST BE APPLIED TO MAINTAIN THE CORRECT WATER LEVEL. A LOW WATER CUTOFF MUST BE OPERATIVE!**

Sec. VIII

# Section IX: Check-out Procedure

## CHECK-OUT PROCEDURE (Check-off steps as completed.)

- 1. System properly filled with water?
- 2. Automatic air vent, if used, open one turn (water boilers only)?
- 3. Air purged from system (water boilers only)?
- 4. Steam boilers properly skimmed?
- 5. Air purged from oil piping? Piping checked for leaks?
- 6. Proper draft and burner flame? Final adjustment made with combustion test equipment?
- 7. Test safety controls: If boiler is equipped with a low water cut-off or additional safety controls, test for operation as outlined by the manufacturer. Burner should be operating and should go off when controls are tested. When safety devices are restored, burner should reignite.
- 8. Test limit control: While burner is operating, move indicator of limit control below actual boiler water temperature or pressure. Burner should go off. Circulator should continue to operate (water boilers only). Raise limit control above boiler water temperature or pressure and burner should reignite.
- 9. Limit control set to the design temperature or pressure requirements of the system? Maximum limit setting—240°F. (water boilers)—15# (steam boilers).
- 10. For multiple zones, flow adjusted so it is about the same in each zone (water boilers only)?
- 11. Thermostat heat anticipator set properly? Refer to wiring diagram.
- 12. Boiler cycled with the thermostat? Raise to highest setting. Boiler should go through normal start-up cycle. Lower to lowest setting. Boiler should go off.
- 13. Several operating cycles observed for proper operation?
- 14. Room thermostat set to desired temperature?
- 15. All instructions shipped with this boiler reviewed with owner or maintenance person, returned to envelope and given to owner or displayed near boiler?

## Section X: Dimensions

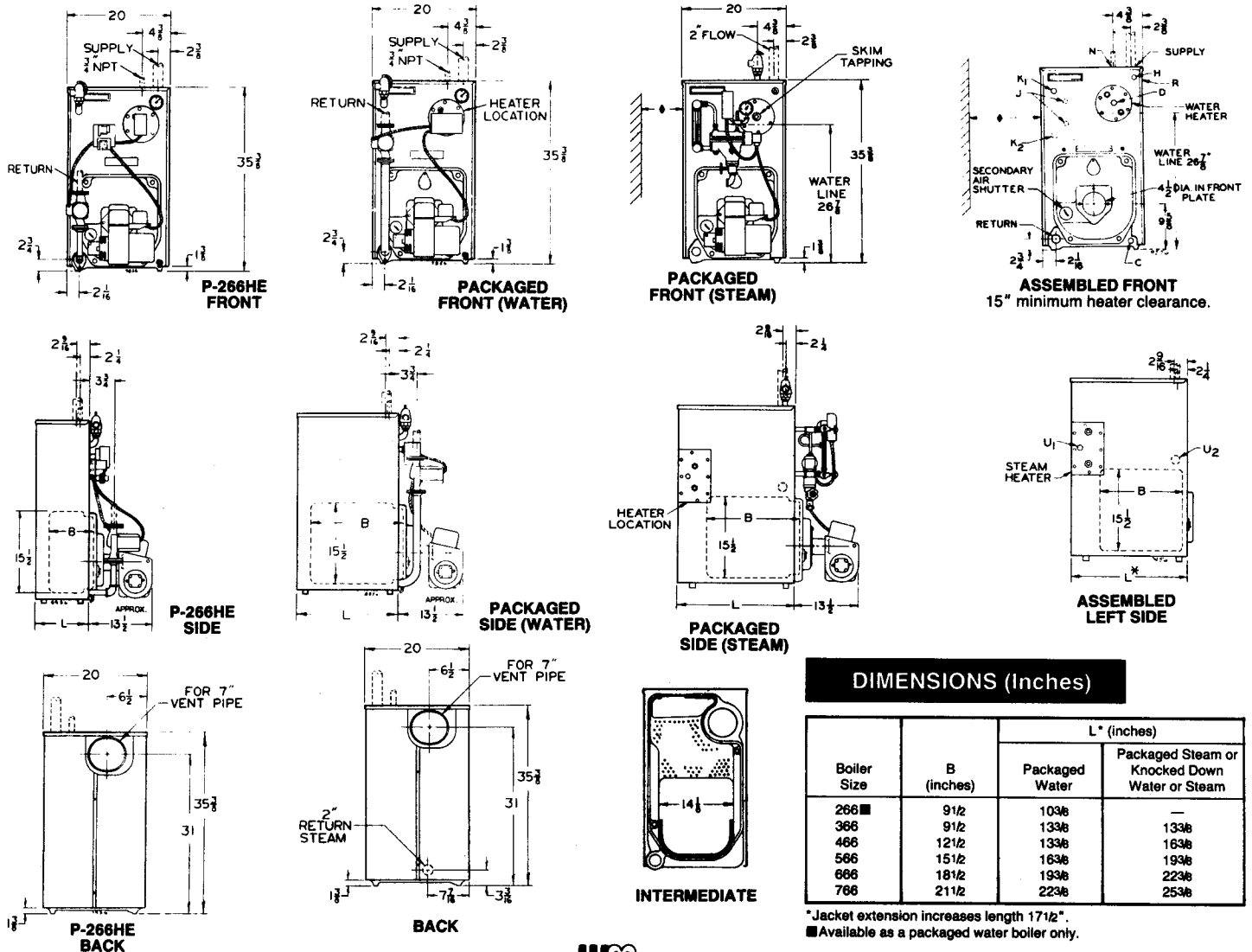

# RATINGS



Boiler Number	I-B-R Burner Capacity GPH	DOE Heating Capacity BTU/Hr.†	Net I-B-R Ratings**			I-B-R Chimney		Boiler Water Content (Gal.)		
			Steam Sq. Ft.	Steam BTU/Hr.	Water BTU/Hr.	Size Inches	Height Feet	Water		Steam
								P-	B or A	
P&B266HE	0.7	83,000	—	—	72,200	8 x 8	15	7.0	—	—
P&B366HE	.95	109,000	340	81,800	94,800	8 x 8	15	13.3	13.3	11.2
P&B466HE	1.25	144,000	450	108,000	125,200	8 x 8	15	8.6	14.9	12.4
P&B566HE	1.50	173,000	540	129,800	150,400	8 x 8	15	10.2	16.5	13.6
P&B666HE	1.80	207,000	645	155,300	180,000	8 x 8	15	11.8	18.1	14.8
P&B766HE	2.05	236,000	740	177,000	205,200	8 x 8	15	13.4	19.7	16.1
A-366E	.95	109,000	340	81,800	94,800	8 x 8	15	—	13.3	11.2
A-466E	1.25	144,000	450	108,000	125,200	8 x 8	15	—	14.9	12.4
A-566E	1.50	173,000	540	129,800	150,400	8 x 8	15	—	16.5	13.6
A-666E	1.80	207,000	645	155,300	180,000	8 x 8	15	—	18.1	14.8
A-766E	2.05	236,000	740	177,000	205,200	8 x 8	15	—	19.7	16.1

†Based on standard test procedures prescribed by the United States Department of Energy at combustion condition of 12.14% ± 1/4% CO<sub>2</sub>.  
 \*\* Net I-B-R ratings are based on net installed radiation of sufficient quantity for the requirements of the building and nothing need be added for normal piping and pick-up. Water ratings are based on a piping and pick-up allowance of 1.15. Steam ratings are based on an allowance of 1,333. An additional allowance should be made for unusual piping and pick-up loads.

## TANKLESS WATER HEATER CAPACITIES

Boiler Size	Heater No.	*Intermittent Draw GPM 100°F. Average Temp. Rise	**Continuous Draw GPM 100°F. Temp. Rise	Inlet and Outlet Tappings	Temp. Control Tapping
<b>WATER</b>					
366	E-624	3.00	2.00	1/2"	3/4"
466	E-624	3.25	2.70	1/2"	3/4"
566	E-624	3.25	3.30	1/2"	3/4"
666	E-626	3.50	4.00	1/2"	3/4"
766	E-632	4.25	4.60	1/2"	3/4"
<b>STEAM</b>					
366	35-S-29	3.00	2.00	3/4"	3/4"
466	35-S-29	3.25	2.70	3/4"	3/4"
566	35-S-29	3.50	3.30	3/4"	3/4"
666	35-S-29	3.75	4.00	3/4"	3/4"
766	35-S-29	4.00	4.60	3/4"	3/4"

Weil-McLain ratings based on 60 PSIG domestic water pressure at heater.  
 \* Gallons of water per minute heated from 40° to 140°F. with 200°F. boiler water temperature.  
 \*\* Continuous draw—no recovery period.  
 ■ Not available on 266HE boilers.

## STORAGE HEATER

Boiler Size*	Storage Heater Number	180° Boiler Water Heater Capacity Gallons 40°-140° Rise	212° Boiler Water Heater Capacity Gallons 40°-140° Rise
566-766	62-2-E	50 in 3 Hours	70 in 3 Hours
Recommended Storage Tank		50-90 Gallons	75-125 Gallons

\*No. 62-2-E storage heater cannot be used with 266 through 566 water boilers or with any steam boilers.

## CONTROL TAPPING

LOCATION	SIZE	WATER	STEAM
C	3/4"	Drain	Drain
D (in plate)	1 1/2"	High-Limit Control (bushed to 3/4")	Skim Tapping
D (in water heater)	3/4"	Combination High-Limit and Operating Control	—
H	1 1/4"	Combination Pressure and Temperature Gauge	Pressure Gauge and Pressure Limit Control
J*	3/8"	—	Try Cock Tappings
K <sub>1</sub>	3/4"	Pressure Relief Valve	Gauge Glass and/or Low-Water Cutoff (bushed to 1/2")
K <sub>2</sub>	3/4"	Plugged	Gauge Glass and/or Low-Water Cutoff (bushed to 1/2")
N	3/4"	To Compression Tank	Safety Valve
R*	3/4"	Limit Control	Limit Control
U <sub>1</sub> (in steam heater)	3/4"	—	Heater Operating Control (366E through 566E Boilers)
U <sub>1</sub>	3/4"	Plugged	Heater Operating Control (666 and 766 Boilers)

\*Available only on special request.

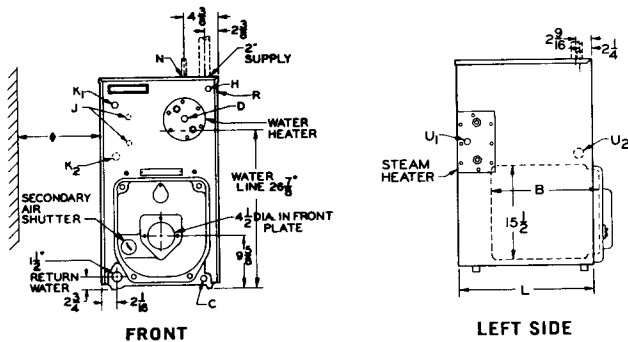

♦ 15" minimum heater clearance.

Sec. XI

# WEIL-McLAIN

Michigan City, Indiana 46360 ■ A Marley Company

In Canada: Marley Fluid Systems, 126 East Dr., Brampton, Ontario L6T 1C2

## Free Manuals Download Website

<http://myh66.com>

<http://usermanuals.us>

<http://www.somanuals.com>

<http://www.4manuals.cc>

<http://www.manual-lib.com>

<http://www.404manual.com>

<http://www.luxmanual.com>

<http://aubethermostatmanual.com>

Golf course search by state

<http://golfingnear.com>

Email search by domain

<http://emailbydomain.com>

Auto manuals search

<http://auto.somanuals.com>

TV manuals search

<http://tv.somanuals.com>