



WELLS MANUFACTURING COMPANY
2 ERIK CIRCLE, P. O. Box 280
Verdi, NV 89439
Customer Service (775) 345-0444 Ext.502
fax: (775) 345-0569
www.wellsbloomfield.com

OPERATION MANUAL
for
ELECTRONIC POP-UP TOASTERS
Models T-4C and T-4C 15A
and
BAGEL TOASTERS
Model BT-4C
Includes
INSTALLATION
USE & CARE



Model T-4C

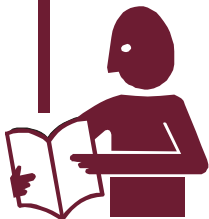

IMPORTANT: DO NOT DISCARD THIS MANUAL

This manual is considered to be part of the appliance and is to be given to the OWNER or MANAGER of the restaurant, or to the person responsible for TRAINING OPERATORS of this appliance. Additional manuals are available from your WELLS DEALER.

THIS MANUAL MUST BE READ AND UNDERSTOOD BY ALL PERSONS USING OR INSTALLING THIS APPLIANCE. Contact your WELLS DEALER if you have any questions concerning installation, operation or maintenance of this equipment.

LIMITED WARRANTY STATEMENT

Unless otherwise specified, all commercial cooking equipment manufactured by WELLS MFG. CO. is warranted against defects in materials and workmanship for a period of one year from the date of original installation or 18 months from the date of shipment from our factory, whichever comes first, and is for the benefit of the original purchaser only.

THIS WARRANTY IS THE COMPLETE AND ONLY WARRANTY, EXPRESSED OR IMPLIED IN LAW OR IN FACT, INCLUDING BUT NOT LIMITED TO, WARRANTIES OF MERCHANTABILITY OR FITNESS FOR ANY PARTICULAR PURPOSE, AND/OR FOR DIRECT, INDIRECT OR CONSEQUENTIAL DAMAGES IN CONNECTION WITH WELLS MFG. CO. PRODUCTS. This warranty is void if it is determined that, upon inspection by an authorized service agency, the equipment has been modified, misused, misapplied, improperly installed, or damaged in transit or by fire, flood or act of God. It also does not apply if the serial nameplate has been removed, or if service is performed by unau-

thorized personnel. The prices charged by Wells Mfg. Co. for its products are based upon the limitations in this warranty. Seller's obligation under this warranty is limited to the repair of defects without charge by a Wells Mfg. Co. factory authorized service agency or one of its sub-service agencies. This service will be provided on customer's premises for non-portable models. Portable models (a device with a cord and plug) must be taken or shipped to the closest authorized service agency, transportation charges prepaid, for service. In addition to restrictions contained in this warranty, specific limitations are shown in the Service Policy and Procedure Guide. Wells Mfg. Co. authorized service agencies are located in principal cities. This warranty is valid in the United States and Canada and void elsewhere. Please consult your classified telephone directory, your foodservice equipment dealer or write the Factory Service Department, Wells Manufacturing Company, P.O. Box 280, Verdi, Nevada 89439, phone (775) 345-0444 or (888) 492-2782, for information and other details concerning warranty.

SERVICE POLICY AND PROCEDURE GUIDE ADDITIONAL WARRANTY EXCLUSIONS

1. Resetting of safety thermostats, circuit breakers, over load protectors, and/or fuse replacements are **not** covered by this warranty unless warranted conditions are the cause.
2. All problems due to operation at **voltages or phase other than specified on equipment nameplates** are **not** covered by this warranty. Conversion to correct voltage and/or phase must be the customer's responsibility.
3. All problems due to **electrical connections not made in accordance with electrical code requirements and wiring diagrams** supplied with the equipment are **not** covered by this warranty.
4. Replacement of items **subject to normal wear**, to include such items as knobs, light bulbs; and, normal maintenance functions including adjustments of thermostats, adjustment of micro switches and replacement of fuses and indicating lights are **not** covered by warranty.
5. Damage to electrical cords and/or plug due to exposure to excessive heat are **not** covered by this warranty.
6. Full use, care, and maintenance instructions supplied with each machine. Noted maintenance and preventative maintenance items, such as servicing and cleaning schedules, are customer responsibility. Those miscellaneous adjustments noted are customer responsibility. Proper attention to preventative maintenance and scheduled maintenance procedures will prolong the life of the appliance.
7. Travel mileage is limited to **sixty (60) miles** from an Authorized Service Agency or one of its sub-service agencies.
8. All labor shall be performed during regular working hours. Overtime premium will be charged to the buyer.
9. All genuine Wells replacement parts are warranted for ninety (90) days from date of purchase on non-warranty equipment. This parts warranty is limited only to replacement of the defective part(s). **Any use of non-genuine Wells parts completely voids any warranty.**
10. Installation, labor, and job check-outs are **not** considered warranty and are thus **not** covered by this warranty.
11. Charges incurred by delays, waiting time or operating restrictions that hinder the service technician's ability to perform service are **not** covered by warranty. This includes institutional and correctional facilities.

SHIPPING DAMAGE CLAIM PROCEDURE

NOTE: For your protection, please note that equipment in this shipment was carefully inspected and packaged by skilled personnel before leaving the factory. Upon acceptance of this shipment, the transportation company assumes full responsibility for its safe delivery.

IF SHIPMENT ARRIVES DAMAGED:

1. **VISIBLE LOSS OR DAMAGE:** Be certain that any visible loss or damage is noted on the freight bill or express receipt, and that the note of loss or damage is signed by the delivery person.
2. **FILE CLAIM FOR DAMAGE IMMEDIATELY:** Regardless of the extent of the damage.

3. **CONCEALED LOSS OR DAMAGE:** if damage is unnoticed until the merchandise is unpacked, notify the transportation company or carrier immediately, and file "CONCEALED DAMAGE" claim with them. This should be done within fifteen (15) days from the date the delivery was made to you. Be sure to retain the container for inspection.

Wells Manufacturing cannot assume liability for damage or loss incurred in transit. We will, however, at your request, supply you with the necessary documents to support your claim.

TABLE OF CONTENTS

WARRANTY	xi
SPECIFICATIONS	1
FEATURES & OPERATING CONTROLS	2
PRECAUTIONS & GENERAL INFORMATION	3
AGENCY APPROVAL INFORMATION	3
INSTALLATION	4
OPERATION	5
CLEANING INSTRUCTIONS	6
TROUBLESHOOTING	7
PARTS & SERVICE	9
CUSTOMER SERVICE DATA	9

Thank You for purchasing this
Wells Manufacturing Co.
Electronic Pop-Up Toaster.

Proper installation, professional
operation and consistent
maintenance of this equipment
will ensure that it gives you the
very best performance and a long,
economical service life.

This manual contains the
information needed to properly
install this equipment, and to use
and care for the equipment in a
manner which will ensure its
optimum performance.

SPECIFICATIONS

DIMENSIONS:

Cabinet	12"H x 13-1/8"W x 9-1/16"D
Bread Slot	1-1/8" x 5-1/4"
Slices per Load	1 to 4

ELECTRICAL:

MODEL	VOLTS	AMPS	kW	PLUG
T-4C	208V	11.5A	2.4 kW	NEMA 6-15P
	240V	10.0A	2.4 kW	NEMA 6-15P
T-4C 15A	120V	15.0A	1.8 kW	NEMA 5-15P
BT-4C	120V	13.3A	1.6 kW	NEMA 5-15P

FEATURES & OPERATING CONTROLS

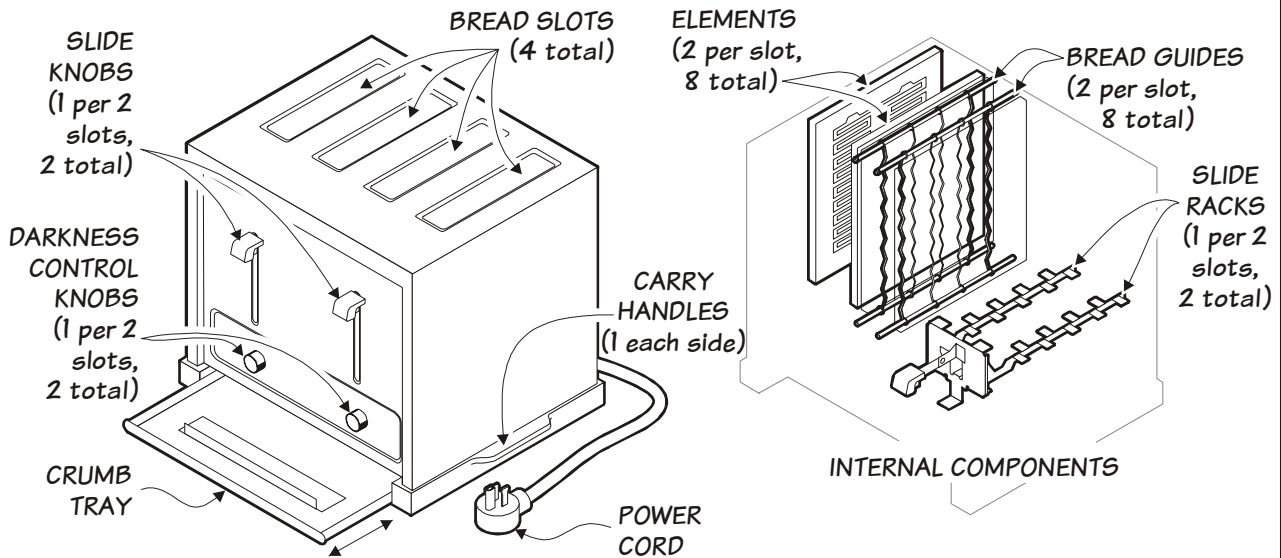

Fig. 1 Toaster Features & Operating Controls

- n BREAD SLOTS One to four pieces of bread, one slice of bread per slot. Oversized to accept Texas toast, English muffin, bagel, etc.
- n BREAD GUIDES Hold bread at proper distance from elements
- n SLIDE RACKS Carriages hold bread slices for toasting. Controlled by slide knobs
- n ELEMENTS Provide toasting heat.
Note: Bagel toaster BT-4C toasts one side (cut side) only. One element in each pair is inert
- n DARKNESS CONTROL KNOBS Individually adjustable from very light to very dark. Control time slide rack is down and elements are energized. Each knob controls one pair of bread slots
- n SLIDE KNOBS Control slide racks. Initiate toasting timer when pushed down. Each knob controls one slide rack (one pair of bread slots)
- n POWER CORD Plugs into appropriate electrical receptacle
- n CARRY HANDLES Carry the toaster here. DO NOT carry the toaster by the bread slots!
- n CRUMB TRAY Crumbs accumulate here. Remove to dump crumbs

PRECAUTIONS AND GENERAL INFORMATION

This appliance is intended for use in commercial establishments only.

This appliance is intended to prepare food for human consumption. No other use is recommended or authorized by the manufacturer or its agents.

Operators of this appliance must be familiar with the appliance use, limitations and associated restrictions. Operating instructions must be read and understood by all persons using or installing this appliance.

Cleanliness of this appliance is essential to good sanitation. Read and follow all included cleaning instructions and schedules to ensure the safety of the food product.

Unplug or disconnect the toaster from electrical power before performing any maintenance or servicing.

DO NOT submerge toaster in water. DO NOT splash or pour water into bread slots, controls, control panel or wiring.

DO NOT lift or carry the toaster by the bread slots. Lift and carry by the carrying handles only.

The technical content of this manual, including any wiring diagrams, schematics, parts breakdown illustrations and/or adjustment procedures, is intended for use by qualified technical personnel.

Any procedure which requires the use of tools must be performed by a qualified technician.

This manual is considered to be a permanent part of the appliance. This manual and all supplied instructions, diagrams, schematics, parts breakdown illustrations, notices and labels must remain with the appliance if it is sold or moved to another location.

This appliance is made in the USA. Unless otherwise noted, this appliance has American sizes on all hardware.

WARNING: Electric Shock hazard



All servicing requiring access to non-insulated electrical components must be performed by a qualified technician. DO NOT open any access panel which requires the use of tools. Failure to follow this warning can result in severe electrical shock.

CAUTION: Risk of Damage



DO NOT connect and/or energize this appliance until all installation instructions are read and followed. Damage to the appliance will result if these instructions are not followed.

AGENCY APPROVAL INFORMATION

This unit complies with NSF standard 4 only if maintained and operated per the instructions in this manual.

This unit is Underwriters Laboratory listed under E6070.



STD 4



E6070

INSTALLATION

NOTE: DO NOT discard the carton or other packing materials until you have inspected the appliance for hidden damage and tested it for proper operation. Refer to *SHIPPING DAMAGE CLAIM PROCEDURE* on the inside front cover of this manual.

DO NOT lift or carry the toaster by the bread slots. This will damage the heating elements. Lift and carry by the carrying handles only.



CAUTION:
Electric Shock
Hazard

The ground prong of the power cord is part of a system designed to protect you from electric shock in the event of internal damage to the appliance.

NEVER CUT OFF THE GROUND PRONG (large round prong). NEVER TWIST A PRONG TO FIT AN EXISTING RECEPTACLE.

If circuit or receptacle does not match the toaster plug, contact a licensed electrician to install an electrical receptacle appropriate to the voltage and amperage requirements of the toaster.

IMPORTANT:

Damage due to being plugged into the wrong voltage or phase is NOT covered by warranty

UNPACKING & INSPECTION

Carefully remove the toaster from the carton. Remove all protective plastic film, packing materials and accessories from the toaster before plugging the toaster into electrical power or otherwise performing any installation procedure.

Carefully read all instructions in this manual and the *Installation Instruction Sheet* packed with the toaster before starting any installation.

Read and understand all labels and diagrams attached to the toaster.

Carefully account for all components and accessories before discarding packing materials. Store all accessories in a convenient place for later use.

SETUP

Setup the toaster only on a firm level surface. Non-combustible material (e.g. metal, terrazzo) is recommended.

ELECTRICAL

Refer to the nameplate. Verify the electrical service power. Voltage and phase must match the nameplate specifications. Plugging the toaster into the wrong voltage can severely damage the equipment or cause noticeably decreased performance.

Your appliance is equipped with a grounded electric power cord. This cord must be plugged into a properly grounded electrical receptacle.

T-4C Toasters are equipped with a 4 foot cord with grounded NEMA 6-15P plug. This cord must be plugged into a 208 or 240 volt, 15 amp circuit with a properly installed and grounded NEMA 6-15R receptacle. Refer to toaster nameplate for proper voltage.

T-4C 15A Toasters and BT-4C Bagel Toasters are equipped with a 4 foot cord with grounded NEMA 5-15P plug. This cord must be plugged into a 120 volt, 15 amp circuit with a properly installed and grounded NEMA 5-15R receptacle.

GENERAL OPERATIONAL NOTES

Carefully read the description of the toaster operation on the specification sheet.

DO NOT attempt to perform any maintenance or service, or attempt to unjamb a slice of toast unless the toaster is unplugged from electrical power.

DO unplug the toaster from electrical power before cleaning, servicing or unjamming.

DO NOT use sharp objects or metal implements to unjamb a slice of toast.

DO use a plastic spatula inserted along the bread guides, away from the elements, to remove toast that is jammed.

DO NOT lift or carry the toaster by the bread slots. This will damage the elements.

DO carry the toaster by the carry handles.

OPERATION

Turn the darkness control knobs to the desired toast color. The knobs may be rotated to the *light* position (fully counter-clockwise for very little color) to the *dark* position (fully clock-wise for dark brown). There are an infinite number of settings between these two extremes. Each knob controls one pair of bread slots.

Experiment with your normal bread product and adjust the darkness control knobs to the desired toast color.

Place one to four bread slices in the bread slots, one per slot. The wide bread slots will accept other large size bread products, such as buns, waffles, English Muffins, Texas-sized toast, etc. When using non-standard bread products, be sure to adjust the darkness control knob for your desired toast color.

Press down on the slide knobs until they stop. The slide rack should move easily, and catch in the *down* position. Each slide knob controls one pair of bread slots (i.e. right or left pair).

Toast time is approximately two minutes (Model T-4C), two or more minutes (Model BT-4C) or three minutes (Model T-4C 15A). These times are only approximate and will vary depending on the darkness setting. Your own experience with your product is your best guide to the best darkness setting.

The slide rack raises automatically at the end of the timed cycle. Slide racks may be manually raised at any time during the timed cycle by lifting the slide knob.

Each successive toasting cycle will require less time as the toaster chamber retains more heat. Adjust the darkness knob as required to maintain your desired toast color.

CAUTION:

Hot Surface

Exposed surfaces can be hot to the touch and may cause burns.

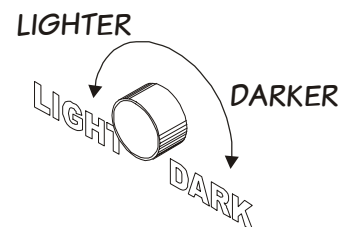

fig. 2 Darkness Control

Note: Model BT-4C Bagel Toaster toasts only one side (cut side) of bagels or buns. Place bagels or buns in the toaster in right or left pairs of bread slots with cut sides facing each other.

CLEANING INSTRUCTIONS



CAUTION:
Electric Shock
Hazard

Unplug toaster from electric power before cleaning.



CAUTION:
Burn Hazard

Allow toaster to cool completely before cleaning.



CAUTION:
Electric Shock
Hazard

Do not submerge toaster in water.

IMPORTANT: DO NOT spill or pour water into bread slots, slide slots or interior of toaster.

IMPORTANT: DO NOT spill or pour water into controls, control panel or wiring.

DO NOT submerge toaster in water. Damage to internal components will occur. Damage to internal components from water damage is **not** covered by warranty.

PREPARATION

Unplug toaster from electrical power before cleaning.
Allow toaster to cool completely before cleaning.

FREQUENCY

Daily

TOOLS

Soft Brush
Clean Cloth or Sponge
Mild Detergent or Cleaner Formulated for Stainless Steel
Warm Water

CLEANING

Unplug toaster and allow to cool completely.

With the slide knobs in the *up* position, wipe both slide racks with a soft brush to remove any remaining food particles. DO NOT attempt to brush or clean elements.

Remove the crumb tray. Empty the crumb tray and wipe with a clean cloth moistened with clean warm water.

Wipe the outer portions of the toaster cabinet with a clean soft cloth or sponge, warm water and a mild detergent or cleaner formulated for cleaning stainless steel.

Rinse by wiping toaster cabinet with a clean soft cloth or sponge moistened with clean warm water.

Dry by wiping with a clean soft dry cloth.

TROUBLESHOOTING

SYMPTOM	POSSIBLE CAUSE	SUGGESTED REMEDY
Toaster won't heat	Not plugged in, damaged plug or cord or circuit breaker tripped	Check plug and cord Check / reset circuit breaker
One or more sections won't heat	BT-4C Bagel Toaster	Bagel Toaster toasts only one side of bagel or bun
	Damaged element or other internal component	Contact Authorized Wells Service Agency for repairs
Slide knob won't catch in the down position	Latch contaminated with crumbs	Keep crumb tray clean
	Damaged internal components	Contact Authorized Wells Service Agency for repairs
Slide rack won't raise at end of toast time	Damaged internal components	Contact Authorized Wells Service Agency for repairs
Toast or bagel too dark or burnt	Darkness control set too dark	Adjust for desired darkness
	Damaged internal components	Contact Authorized Wells Service Agency for repairs
Toast or bagel too light	Darkness control set too light	Adjust for desired darkness
	Damaged internal components	Contact Authorized Wells Service Agency for repairs

NOTE: There are no user serviceable components in the toaster. In all cases of damage or component malfunction, contact your Authorized Wells Service Agency for repairs.

THIS PAGE BLANK

PARTS & SERVICE

DESCRIPTION

SERVICE PART NO.

TOASTER STAND
KNOB, DARKNESS CONTROL
KNOB, SLIDE
CRUMB TRAY

20931
60007
60008
60037

IMPORTANT: Use only factory authorized service parts and replacement filters.

For factory authorized service, or to order factory authorized replacement parts, contact your Wells authorized service agency, or call:

Wells Manufacturing Co.
2 Erik Circle
P. O. Box 280
Verdi, NV 89439
phone: (775) 345-0444
fax: (888) 492-2783
(Service Parts Dept.)

Service Parts Department can supply you with the name and telephone number of the WELLS AUTHORIZED SERVICE AGENCY nearest you.

CUSTOMER SERVICE DATA

please have this information available if calling for service

RESTAURANT _____ LOCATION _____
INSTALLATION DATE _____ TECHNICIAN _____
SERVICE COMPANY _____
ADDRESS _____ STATE _____ ZIP _____
TELEPHONE NUMBER (____) _____ - _____

EQUIPMENT MODEL NO. _____
EQUIPMENT SERIAL NO. _____
VOLTAGE: (check one) 120 208 240

SERVICE TRAINING - QUALITY SERVICE



CUSTOMER SATISFACTION



WELLS MANUFACTURING COMPANY
2 ERIK CIRCLE, P. O. Box 280
Verdi, NV 89439
Customer Service (775) 345-0444 Ext.502
fax: (775) 345-0569
www.wellsbloomfield.com

Free Manuals Download Website

<http://myh66.com>

<http://usermanuals.us>

<http://www.somanuals.com>

<http://www.4manuals.cc>

<http://www.manual-lib.com>

<http://www.404manual.com>

<http://www.luxmanual.com>

<http://aubethermostatmanual.com>

Golf course search by state

<http://golfingnear.com>

Email search by domain

<http://emailbydomain.com>

Auto manuals search

<http://auto.somanuals.com>

TV manuals search

<http://tv.somanuals.com>