

# WESLO®

# CADENCE E-30

Model No. WATL27205.1

Serial No. \_\_\_\_\_

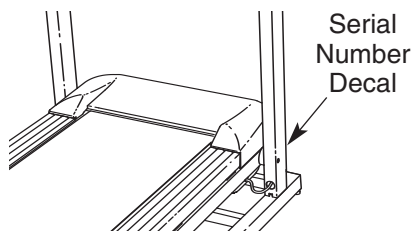

## USER'S MANUAL

### QUESTIONS?

If you have questions, or if there are missing or damaged parts, we will guarantee complete satisfaction through direct assistance from our factory.

**TO AVOID DELAYS, PLEASE CALL DIRECT TO OUR TOLL-FREE CUSTOMER HOT LINE.**  
The trained technicians on our Customer Hot Line will provide immediate assistance, free of charge to you.

**CUSTOMER HOT LINE:**  
**800-820-0915**

E-mail:  
newlife@vip.163.com

ICON's Web site:  
www.iconfitness.com

### CAUTION

Read all precautions and instructions in this manual before using this equipment. Save this manual for future reference.

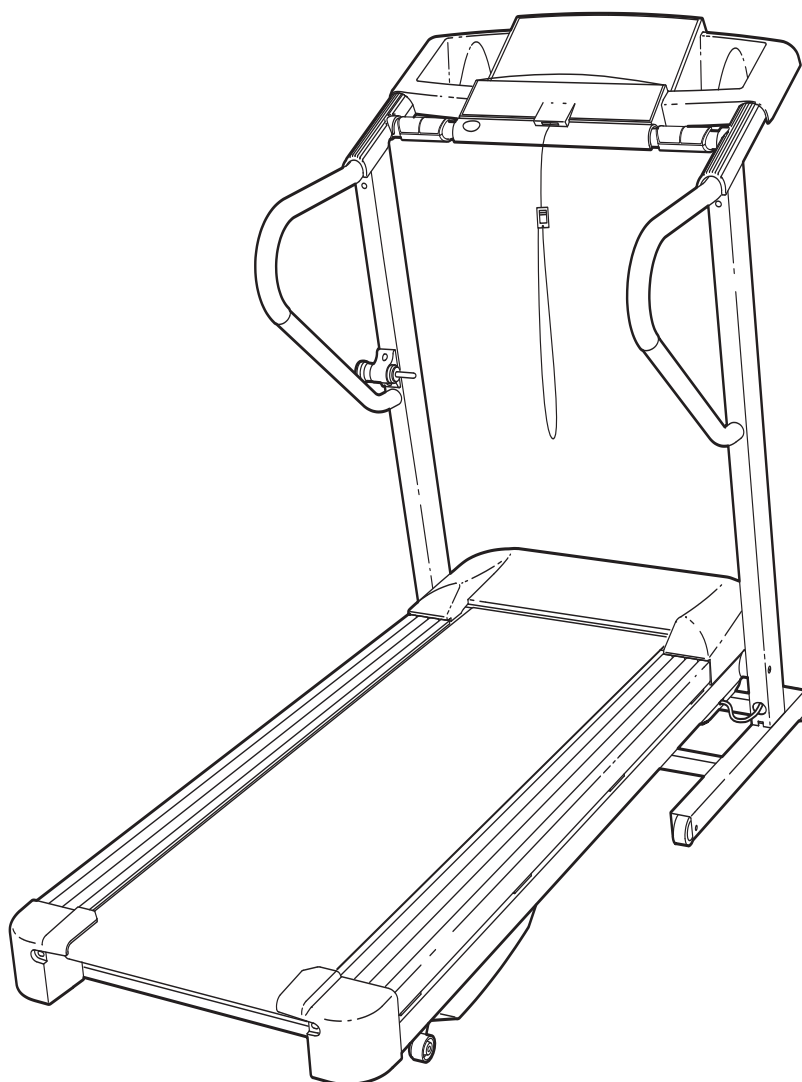

Newlife is an authorized dealer of this treadmill in the territory of mainland China. This treadmill is designed and manufactured by ICON Health & Fitness, Inc.

# WESLO®

# CADENCE E-30

---

## TABLE OF CONTENTS

IMPORTANT PRECAUTIONS .....	3
BEFORE YOU BEGIN .....	5
ASSEMBLY .....	6
OPERATION AND ADJUSTMENT .....	10
HOW TO FOLD AND MOVE THE TREADMILL .....	16
TROUBLESHOOTING .....	17
CONDITIONING GUIDELINES .....	19
ORDERING REPLACEMENT PARTS .....	Back Cover

Note: A PART IDENTIFICATION CHART, an EXPLODED DRAWING, and a PART LIST are attached in the centre of this manual.

# IMPORTANT PRECAUTIONS

**⚠ WARNING:** To reduce the risk of burns, fire, electric shock, or injury to persons, read the following important precautions and information before operating the treadmill.

1. It is the responsibility of the owner to ensure that all users of this treadmill are adequately informed of all warnings and precautions.
2. Use the treadmill only as described.
3. Place the treadmill on a level surface, with at least 2.5 m (8 ft.) of clearance behind it and 0.5 m (2 ft.) on each side. Do not place the treadmill on any surface that blocks air openings. To protect the floor or carpet from damage, place a mat under the treadmill.
4. Keep the treadmill indoors, away from moisture and dust. Do not put the treadmill in a garage or covered patio, or near water.
5. Do not operate the treadmill where aerosol products are used or where oxygen is being administered.
6. Keep children under the age of 12 and pets away from the treadmill at all times.
7. The treadmill should not be used by persons weighing more than 115 kg (250 lbs.).
8. Never allow more than one person on the treadmill at a time.
9. Wear appropriate exercise clothes while using the treadmill. Do not wear loose clothes that could become caught in the treadmill. Athletic support clothes are recommended for both men and women. *Always wear athletic shoes. Never use the treadmill with bare feet, wearing only stockings, or in sandals.*
10. When connecting the power cord (see page 10), plug the power cord into an earthed circuit. No other appliance should be on the same circuit. When replacing the fuse, an ASTA approved BS1362 type should be fitted to the fuse carrier. A 13 amp fuse should be used.
11. If an extension cord is needed, use only a 3-conductor, 1mm<sup>2</sup> (14-gauge) cord that is no longer than 1.5 m (5 ft.).
12. Keep the power cord away from heated surfaces.
13. Never move the walking belt while the power is turned off. Do not operate the treadmill if the power cord or plug is damaged, or if the treadmill is not working properly. (See TROUBLESHOOTING on page 17 if the treadmill is not working properly.)
14. Read, understand, and test the emergency stop procedure before using the treadmill (see OPERATION AND ADJUSTMENT).
15. Never start the treadmill while you are standing on the walking belt. Always hold the handrails while using the treadmill.
16. The treadmill is capable of high speeds. Adjust the speed in small increments to avoid sudden jumps in speed.
17. The pulse sensor is not a medical device. Various factors, including your movement, may affect the accuracy of heart rate readings. The pulse sensor is intended only as an exercise aid in determining heart rate trends in general.
18. Never leave the treadmill unattended while it is running. Always remove the key, unplug the power cord, and move the on/off switch to the "off" position when the treadmill is not in use. (See the drawing on page 5 for the location of the on/off switch.)
19. Do not attempt to raise, lower, or move the treadmill until it is properly assembled. (See ASSEMBLY on page 6 and HOW TO MOVE THE TREADMILL on page 16.) You must be able to safely lift 45 pounds (20 kg) to raise, lower, or move the treadmill.
20. Do not change the incline of the treadmill by placing objects under the treadmill.
21. When folding or moving the treadmill, make sure that the frame is securely held by the lock pin.
22. Inspect and properly tighten all parts of the treadmill regularly.
23. Never drop or insert any object into any opening.

24. **DANGER:** Always unplug the power cord immediately after use, before cleaning the treadmill, and before performing the maintenance and adjustment procedures described in this manual. Never remove the motor hood unless instructed to do so by an authorized service representative. Servicing

other than the procedures in this manual should be performed by an authorized service representative only.

25. This treadmill is intended for in-home use only. Do not use this treadmill in any commercial, rental, or institutional setting.

**⚠ WARNING:** Before beginning this or any exercise program, consult your physician. This is especially important for persons over the age of 35 or persons with pre-existing health problems. Read all instructions before using. Newlife assumes no responsibility for personal injury or property damage sustained by or through the use of this product.

## SAVE THESE INSTRUCTIONS

A warning decal in Chinese has been placed on the treadmill in the location shown at the right. An English decal with the same information is included. If desired, apply the English decal on top of the Chinese decal. If the decal is missing or illegible, call the telephone number on the front cover of this manual and order a free replacement decal. Apply the decal in the location shown.

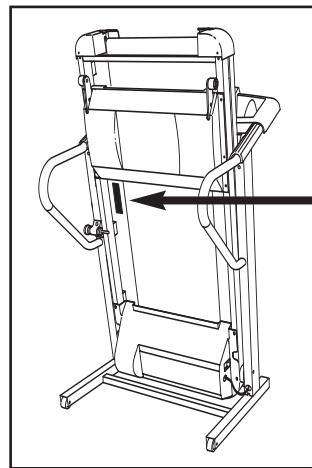

**⚠ WARNING:**

Protect yourself and others from risk of serious injury. Read the user's manual and :

- Stand only on the side rails when starting or stopping treadmill.
- Change speed in small increments.
- Hold handrails to prevent falling, and always wear the safety clip while operating treadmill.
- Stop if you feel faint, dizzy, or short of breath.
- Fully engage storage latch before treadmill is moved or stored.
- Reduce incline to its lowest level before folding treadmill into storage position.

 • Never allow children on or around treadmill.

• Remove key when not in use.

 • Keep clothing, fingers, and hair away from moving belt.

• Never try to adjust or fix the belt while it is moving.

• Always wear athletic shoes while operating treadmill.

# BEFORE YOU BEGIN

Thank you for selecting the new WESLO® E-30 treadmill. The E-30 treadmill offers an impressive array of features designed to help you achieve your fitness goals in the convenience and privacy of your home. And when you're not exercising, the unique E-30 treadmill can be folded up, requiring less than half the floor space of conventional treadmills.

**For your benefit, read this manual carefully before using the treadmill.** If you have questions after read-

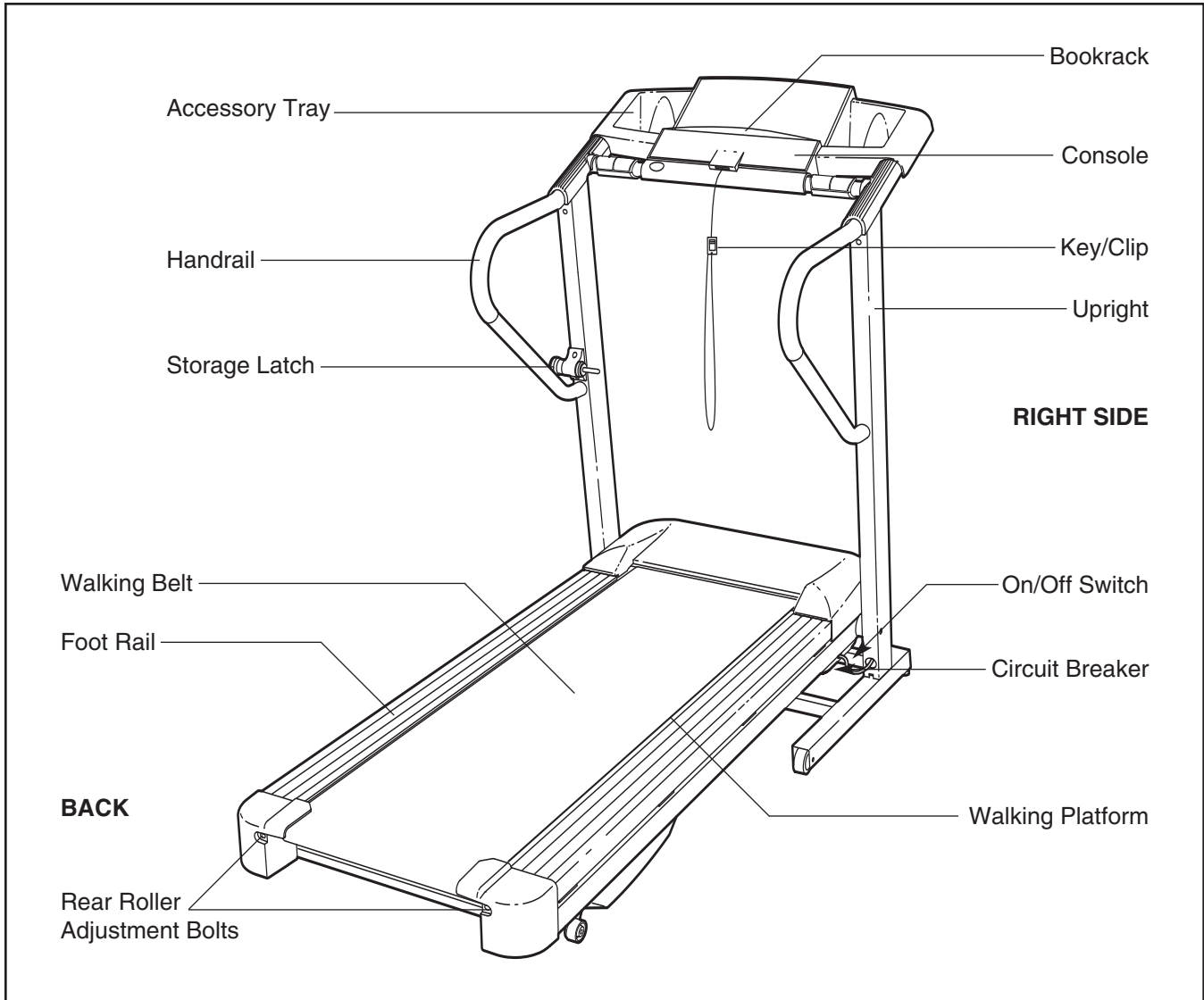

ing this manual, see the front cover of this manual. To help us assist you, please note the product model number and serial number before contacting us. The model number of the treadmill is WATL27205.1. The serial number can be found on a decal attached to the treadmill (see the front cover of this manual for the location).

Before reading further, please familiarise yourself with the parts that are labelled in the drawing below.



# ASSEMBLY

**Assembly requires two persons.** Set the treadmill in a cleared area and remove all packing materials. Do not dispose of the packing materials until assembly is completed. Note: The underside of the treadmill walking belt is coated with high-performance lubricant. During shipping, a small amount of lubricant may be transferred to the top of the walking belt or the shipping carton. This is a normal condition and does not affect treadmill performance. If there is lubricant on top of the walking belt, simply wipe off the lubricant with a soft cloth and a mild, non-abrasive cleaner.

Assembly requires the included hex keys  and your own phillips screwdriver , wire cutters , and needlenose pliers .

**For help identifying the assembly hardware, see the PART IDENTIFICATION CHART in the centre of this manual. Note: The assembly hardware and other small parts are packaged in separate part bags. Do not open the part bags until instructed to do so.**

## 1. Make sure that the power cord is unplugged.

Place the Base (79) in the position shown, with the indicated small holes on top. Next, place the Wheels (63) into the ends of the Base.

**Open part bag A.** Attach the Wheels (63) to the Base (79) with 2" Bolts (61) and Wheel Nuts (64). **Make sure that the Wheel Nuts are on the sides shown; do not overtighten the Bolts; the Wheels should turn freely.**

Attach the four Base Pads (73) to the Base (79) with four 1" Tek Screws (60) (three are shown).

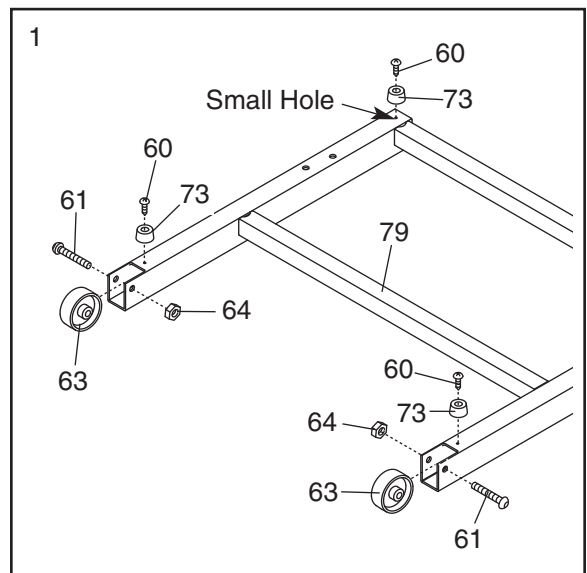

## 2. Raise the Base (79) to a vertical position, and hold it near the treadmill Frame (96) as shown. **Make sure that the Wheels (63) are in the indicated position.**

Identify the Right Upright (104), which has a large round hole in the indicated location. Feed the Wire Harness (65) into the hole and out of the top of the Right Upright. Make sure that there are two U-nuts (74) in the lower end of the Right Upright (see drawing 2a). Hold the Right Upright against the Base (79) as shown. **Make sure that the Right Upright is oriented so the pivot hole is in the position shown.** Hand tighten two 3" Bolts (58) with two 5/16" Star Washers (57) into the Base and the Right Upright.

Attach the Left Upright (47) to the Base (79) in the same way. Note: There is not a wire harness on the left side.

With the help of a second person, raise the Uprights (47, 104) to a vertical position.

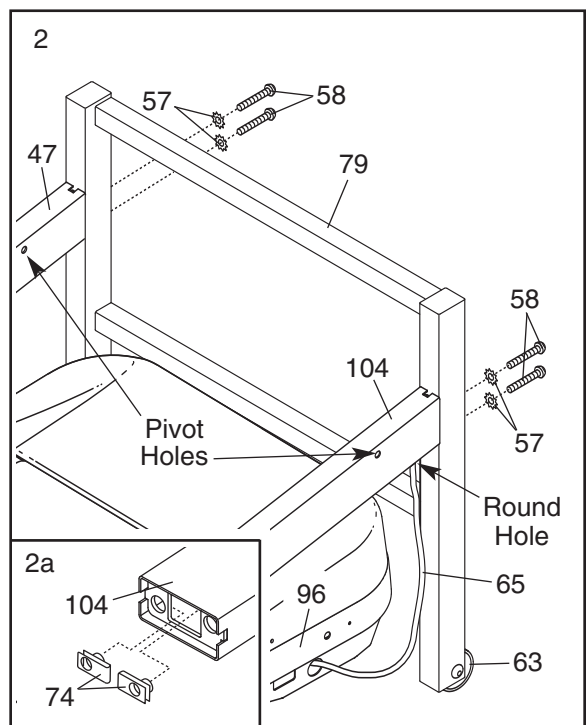

- Hold an Upright Spacer (59) against one side of the Frame (96) as shown. Insert a 4" Frame Bolt (54) into the indicated hole in the Upright Spacer and the Frame. Next, tighten a 3/4" Tek Screw (9) into the Upright Spacer and the Frame. Then, remove the 4" Frame Bolt. Repeat this procedure on the other side of the Frame.

Have a second person lift the front end of the Frame (96). Insert a 4" Frame Bolt (54) with a 3/8" Washer (12) and a 3/8" Star Washer (55) into the Right Upright (104) and the right Upright Spacer (59), and tighten the Frame Bolt into the Frame. **Do not overtighten the Frame Bolt.** Repeat this procedure on the left side of the Frame.

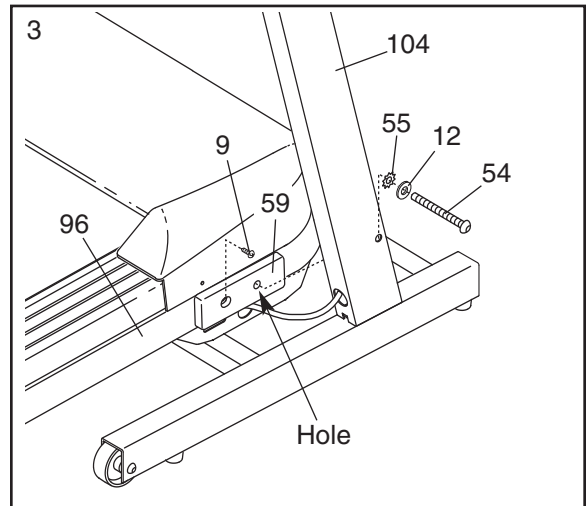

- Attach the Latch Housing (46) to the Left Upright (47) with two 3/4" Screws (38). **Make sure that the large hole in the Latch Housing is on the side shown.**

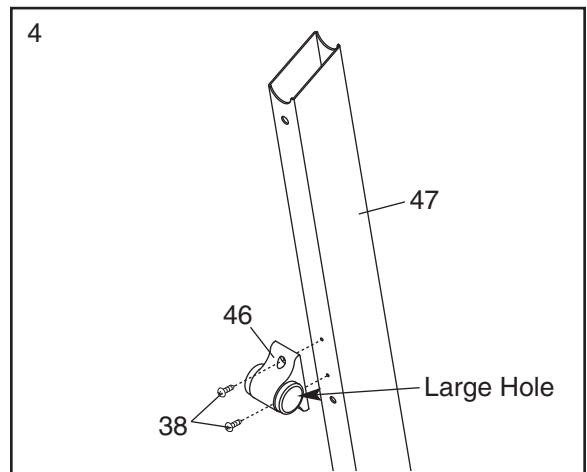

- Identify the Right Handrail (40), which has a pulse bar bracket on its left side. Feed the Wire Harness (65) up into the large bracket on the Right Handrail and out of the large hole in the left side. (Note: It may be helpful to use needlenose pliers to pull the Wire Harness out of the hole.) Remove any nylon ties from the large bracket.

Insert the large bracket on the Right Handrail (40) into the upper end of the Right Upright (104). Attach the Right Handrail with two 1" Bolts (43), two 1/4" Washers (44), two 1/4" Star Washers (45), a 4" Handrail Bolt (78), and a 5/16" Washer (106) as shown. **Do not tighten the Bolts yet.**

See drawing 5a. Insert the included nylon tie through the indicated hole in the Right Handrail (40). See drawing 5b. Look into the Right Handrail and make sure that the Wire Harness (65) is secured to the side shown. Then, tighten the nylon tie and cut the excess off the end.

Attach the Left Handrail (not shown) in the same way. Note: You may need to tip the Left Handrail to one side as you insert the bracket. There is not a wire harness in the left Upright (not shown).

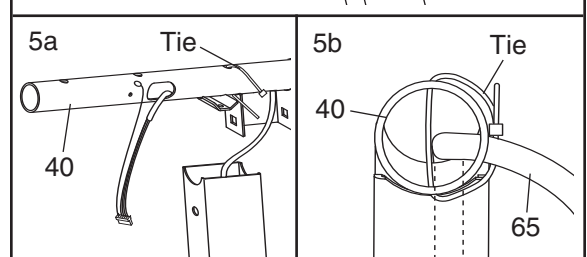
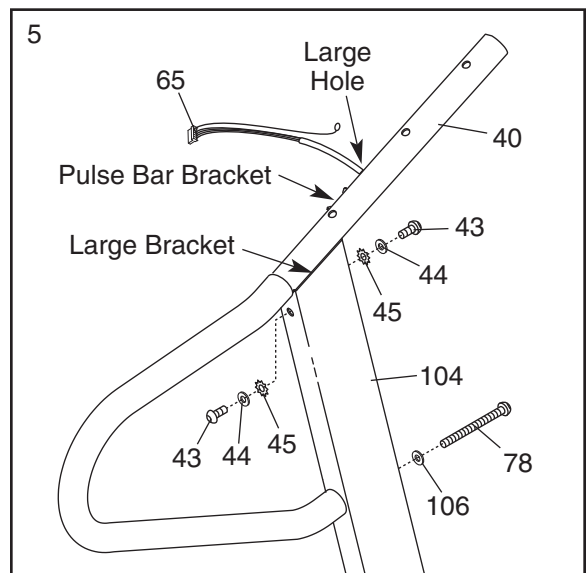



- Attach the end of the ground wire to the small hole in the side of the Right Handrail (40) with a Silver Ground Screw (66).

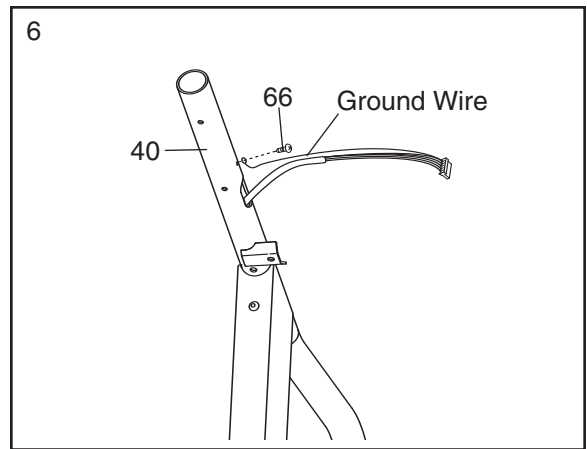

- Set the console assembly onto the Left and Right Handrails (13, 40). **Be careful not to pinch the Wire Harness (65).** Tighten two Pulse Bar Screws (37), with two #10 Star Washers (108), through the brackets on the Handrails and into the Pulse Bar (39). **Do not tighten the Pulse Bar Screws yet.**

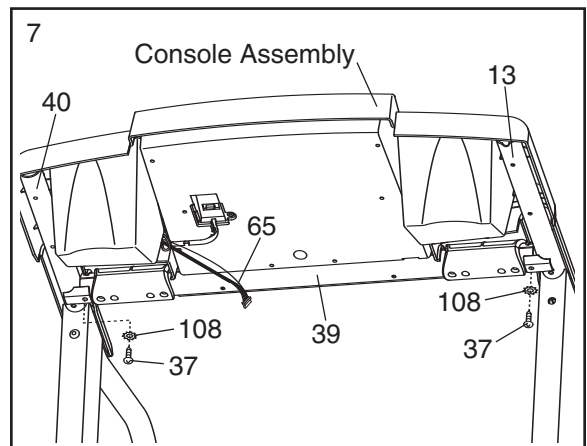

- Insert the Wire Harness (65) through the indicated nylon tie on the Console Base (67). Next, **touch the Right Handrail (40) to discharge any static.** See drawing 8a. Insert the connector on the end of the Wire Harness into the red socket beneath the Console (69). **The connector should slide easily into the socket and snap into place.** If the connector does not slide easily and snap into place, turn it and then insert it. **IF THE CONNECTOR IS NOT INSERTED PROPERLY, THE CONSOLE MAY BE DAMAGED WHEN THE POWER IS TURNED ON.**

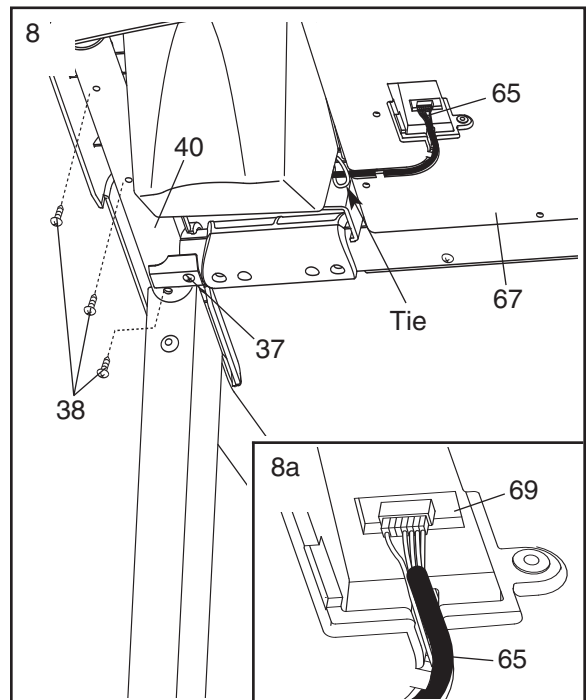

Identify the 3/4" Screws (38). Attach the Console Base (67) to the Right Handrail (40) and the Left Handrail (not shown) with six 3/4" Screws (only three Screws are shown). **Start all six Screws before tightening them; do not overtighten the Screws.**

**Tighten the Pulse Bar Screws (37).**



9. Press the Wire Harness (65) into the indicated track in the Console Base (67). (Note: If there is a cylinder on the Wire Harness that will not fit into the track, press as much of the Wire Harness as possible into the track.) Next, insert the excess Wire Harness into the large hole in the side of the Right Handrail (40). **Securely tighten the nylon tie to prevent the Wire Harness from slipping**, and then cut off the end of the nylon tie.

Attach the Access Door (84) to the Console Base (67) with the 3/4" Screw (38).

**See step 5. Tighten, but do not overtighten, the 1" Bolts (43) and the 4" Handrail Bolts (78).**

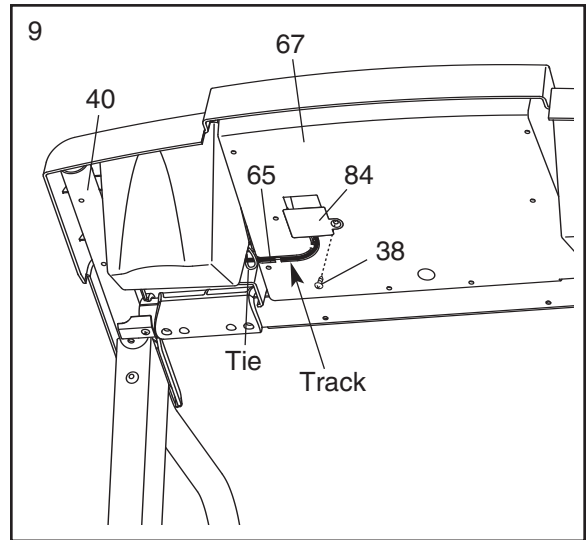

10. Lower the Handrails (13, 40) until they are touching the floor.

See drawing 10a. Position the Handrails (13, 40) so the treadmill Frame (96) is centered between them.

Firmly tighten the four 3" Bolts (58) and the two 4" Frame Bolts (54). **Be careful not to overtighten the Bolts.**

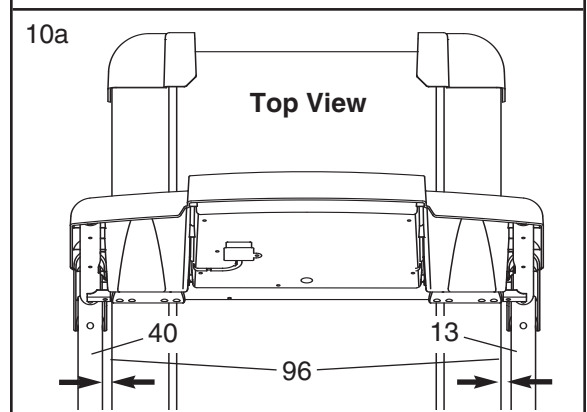
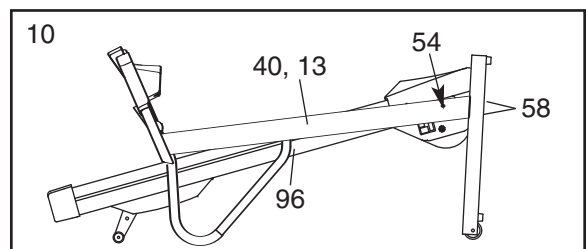

11. Remove the knob from the pin. **Make sure that the collar and the spring are on the pin.** Insert the pin into the Latch Housing (46), and then tighten the knob back onto the pin.

12. **Make sure that all parts are properly tightened before you use the treadmill.** Note: Extra hardware may be included. Keep the included hex keys in a secure place; the large hex key is used to adjust the walking belt (see page 18). To protect the floor or carpet, place a mat under the treadmill.

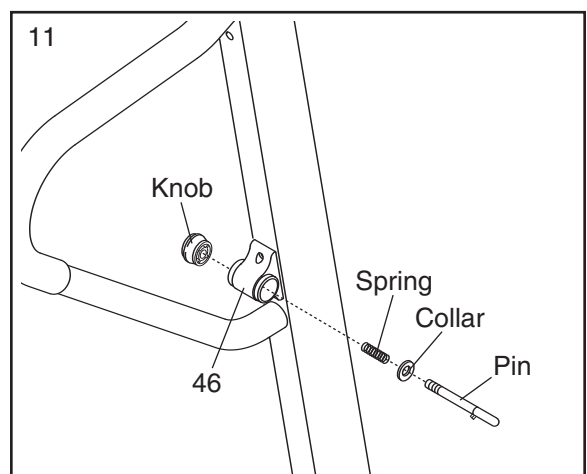

# OPERATION AND ADJUSTMENT

## THE PRE-LUBRICATED WALKING BELT

Your treadmill features a walking belt coated with high-performance lubricant. **IMPORTANT: Never apply silicone spray or other substances to the walking belt or the walking platform. Such substances will deteriorate the walking belt and cause excessive wear.**

## HOW TO PLUG IN THE POWER CORD

**This product must be earthed.** If it should malfunction or break down, earthing provides a path of least resistance for electric current to reduce the risk of electric shock. This product is equipped with a power cord having an equipment-earthing conductor and an earthing plug. **Important: If the power cord is damaged, it must be replaced with a manufacturer-recommended power cord.**

See drawing 1. Plug the indicated end of the power cord into the socket on the treadmill.

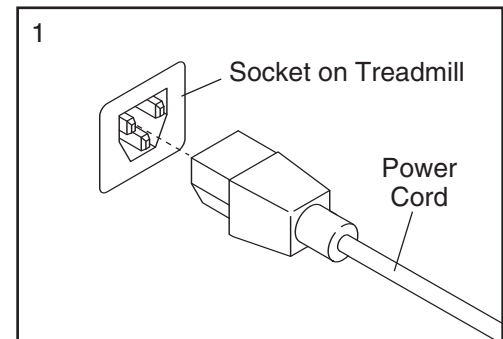

See drawing 2. Plug the power cord into an appropriate outlet that is properly installed and earthed in accordance with all local codes and ordinances. **Important: The treadmill is not compatible with GFCI-equipped outlets.**

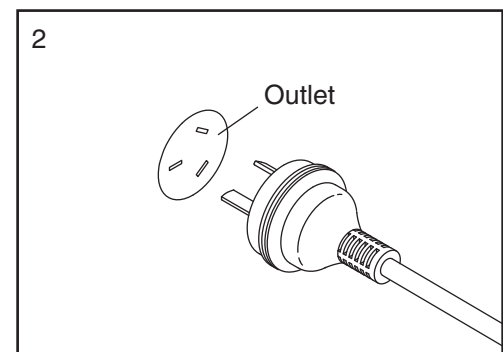

**⚠ DANGER:** Improper connection of the equipment-earthing conductor can result in an increased risk of electric shock. Check with a qualified electrician or serviceman if you are in doubt as to whether the product is properly earthed. Do not modify the plug provided with the product—if it will not fit the outlet, have a proper outlet installed by a qualified electrician.

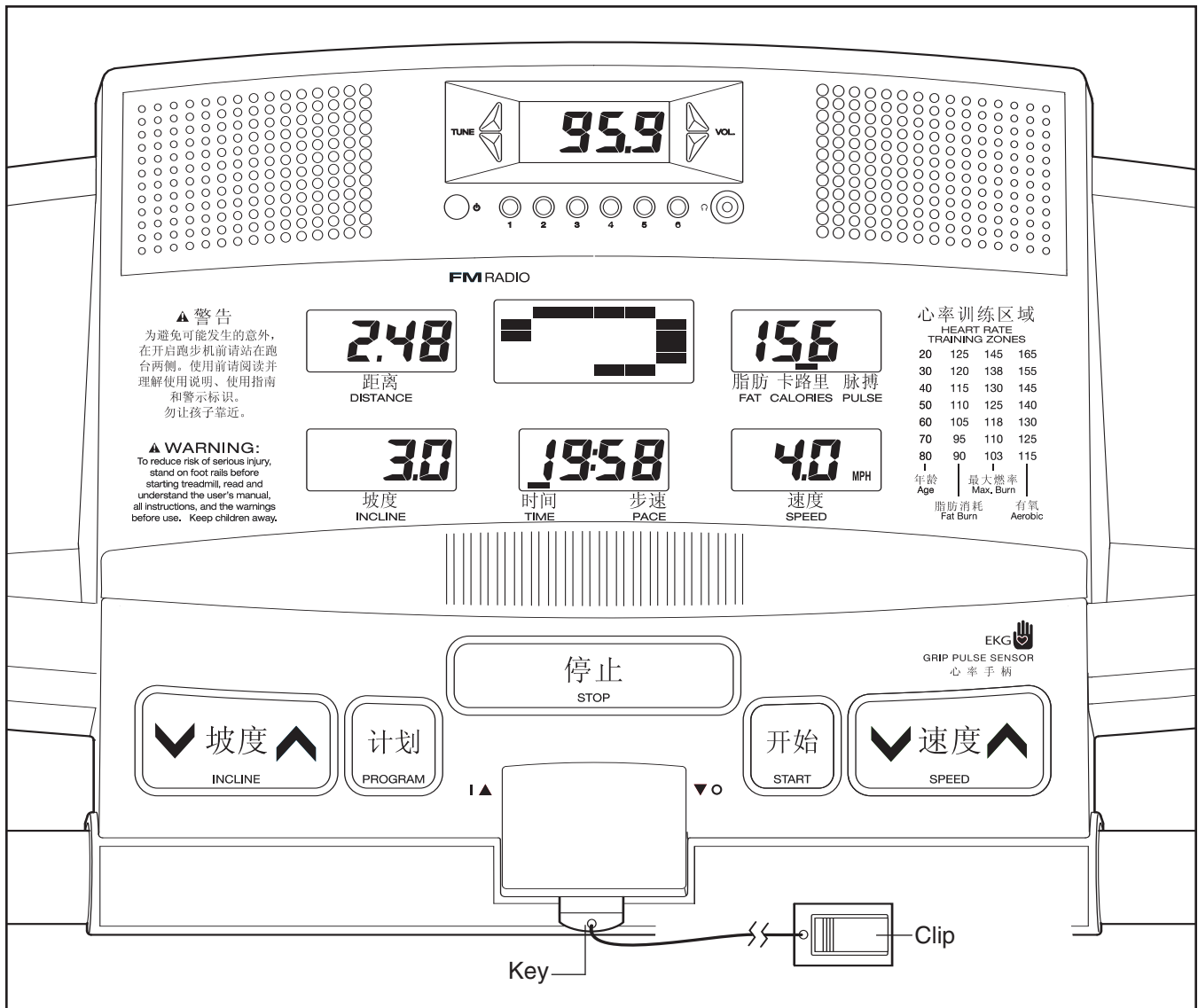

## FEATURES OF THE CONSOLE

The treadmill console offers a selection of features designed to make your workouts more effective and enjoyable. When the manual mode of the console is selected, the speed and incline of the treadmill can be changed with the touch of a button. As you exercise, the displays will provide continuous exercise feedback. You can even measure your heart rate using the hand-grip pulse sensor.

In addition, the console offers eight preset programs. Each program automatically controls the speed and incline of the treadmill as it guides you through an effective workout.

To use the manual mode of the console, follow the steps beginning on page 12. To use a preset program, see page 14.

Whether you select the manual mode or a preset program, you can listen to your favorite FM radio station while you get in shape.

Note: If there is a sheet of clear plastic on the face of the console, peel off the plastic. To prevent damage to the walking platform, wear clean athletic shoes while using the treadmill. The first time the treadmill is used, observe the alignment of the walking belt, and center the walking belt if necessary (see page 18).

## HOW TO TURN ON THE POWER

Plug in the power cord (see page 11). Next, locate the on/off switch on the right side of the treadmill frame near the right upright. Make sure that the switch is in the “on” position.

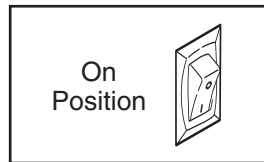

Next, stand on the foot rails of the treadmill. Find the clip attached to the key (see the drawing on page 11) and attach the clip securely to the waistband of your clothes. Then, insert the key into the console. After a moment, the displays will light. **Important: In an emergency situation, the key can be pulled from the console, causing the walking belt to slow to a stop. Test the clip by carefully taking a few steps backward until the key is pulled from the console. If the key is not pulled from the console, adjust the position of the clip as needed.**

## HOW TO USE THE MANUAL MODE

### 1 Insert the key fully into the console.

See HOW TO TURN ON THE POWER above.

### 2 Select the manual mode.

When the key is inserted, the manual mode will be selected and a track will appear in the center of the console. If you have selected a program, remove the key and then reinsert it to select the manual mode.

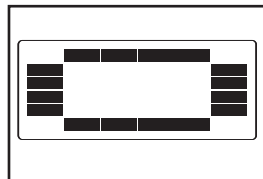

### 3 Press the Start button or the Speed increase button to start the walking belt.

A moment after the button is pressed, the walking belt will begin to move at 1 mph. Hold the handrails and begin walking.

As you exercise, change the speed of the walking belt as desired by pressing the Speed increase and decrease buttons. Each time a button is pressed, the speed setting will change by 0.1 mph. If a button is held down, the speed setting will change in increments of 0.5 mph.

To stop the walking belt, press the Stop button. The Time/Pace display will begin to flash. To restart the walking belt, press the Start button or the Speed increase button.

### 4 Change the incline of the treadmill as desired.

To change the incline of the treadmill, press the Incline increase or decrease button. Each time a button is pressed, the incline will change by 0.5%.

### 5 Follow your progress with the track and the displays.

**The track**—The track in the center of the console represents a distance of 1/4 mile (400 meters). As you walk or run on the treadmill, the indicators around the track will light in succession until the entire track is lit. The track will then disappear and the indicators will again begin to light in succession.

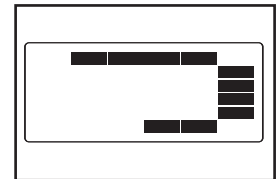

#### Distance display—

This display shows the distance that you have walked or run.



#### Fat/Cals/Pulse display—

This display shows the approximate numbers of *fat calories* and *calories* you have burned (see FAT



BURNING on page 19). The display will alternate between one number and the other every few seconds, as shown by the indicators in the display. The display will also show your heart rate when you use the pulse sensor (see step 6 on page 13).

**Incline display**—This display shows the incline level of the treadmill.



**Time/Pace display**—When the manual mode is selected, this display will show the elapsed time and your pace (pace is measured in minutes per mile or minutes per kilometer). The display will alternate between one number and the other every few seconds, as shown by the indicators in the display. When a speed program is selected, the display will show the time remaining in the program and your pace.



**Speed display**—This display shows the speed of the walking belt.



Note: The console can display speed and distance in either miles or kilometers. The letters “MPH” or “Km/H” will appear in the Speed display to show which unit of measurement is selected. To change the unit of measurement, first select the console’s information mode by holding down the Stop button, inserting the key into the console, and then releasing the Stop button. An “E” for English miles or an “M” for metric kilometers will appear in the Incline display. Press the Speed increase button to change the unit of measurement.

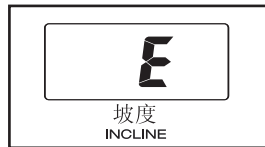

While the information mode is selected, the Distance display will show the total number of miles (or kilometers)



that the walking belt has moved, and the Time/Pace display will show the total number of hours that the treadmill has been used.



**Important:** If a “d” appears in the Speed display, the console is in the “demo” mode. This mode is intended to be used only while a treadmill is displayed in a store. While the console is in the demo mode, the power cord can be plugged in, the key can be removed from the console, and the displays will automatically light in a preset sequence. The buttons on the console will not operate. **If a “d” appears, press the Speed decrease button so the “d” disappears.**

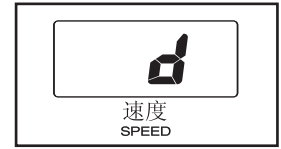

To exit the information mode at any time, remove the key from the console.

## 6 Measure your heart rate if desired.

Before using the handgrip pulse sensor, remove the sheets of clear plastic from the metal contacts. In addition, make sure that your hands are clean.

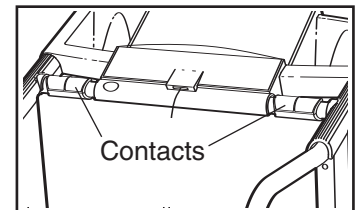

To measure your heart rate, **stand on the foot rails** and hold the metal contacts—**avoid moving your hands**. When your pulse is detected, the heart symbol in the Fat/Cals/Pulse display will flash, one or two dashes will appear, and then your heart rate will be shown. **For the most accurate heart rate reading, continue to hold the contacts for about 15 seconds.**

## 7 Listen to your favorite FM radio station if desired.

Press the Power button to turn on the radio. Next, press the Tune buttons to select the desired FM radio station. Then, press the Volume buttons to adjust the volume of the speakers. Note: A pair of headphones (not included) can be plugged into the headphone jack.

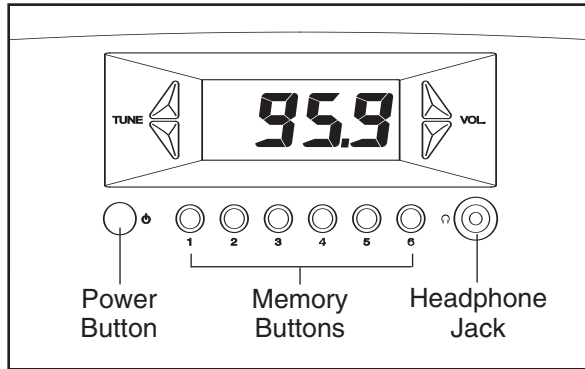

If desired, you can save your favorite FM radio stations in memory. Up to six radio stations can be saved. First, press the Tune buttons to select a radio station. Then, press and hold one of the six Memory buttons for several seconds until a series of tones sounds. The radio station will then be saved. To select the radio station again, press the same Memory button.

If radio reception is poor, reposition the treadmill until the reception is improved.

## 8 When you are finished exercising, remove the key.

Step onto the foot rails, press the Stop button, and adjust the incline of the treadmill to the lowest level. **The incline must be at the lowest level when the treadmill is raised to the storage position or the treadmill will be damaged.** Next, remove the key from the console and put the key in a secure place.

When you are finished using the treadmill, switch the on/off switch to the "off" position.

## HOW TO USE A PRESET PROGRAM

### 1 Insert the key into the console.

See HOW TO TURN ON THE POWER on page 12.

### 2 Select one of the eight preset programs.

Press the Program button repeatedly until the desired preset program is selected. When a program is selected, the maximum incline setting of the program will flash for several seconds in the Incline display, and the maximum speed setting of the program will flash for several seconds in the Speed display. The Time/Pace display will show how long the program will last. A profile of the speed settings of the program will scroll across the matrix.



### 3 Press the Start button or the Speed increase button to start the program.

A moment after the button is pressed, the treadmill will automatically adjust to the first speed and incline settings of the program. Hold the handrails and begin walking.

Each program consists of either 30 or 60 one-minute segments. One speed setting and one incline setting are programmed for each segment. Note: The same speed setting and/or incline setting may be programmed for two or more consecutive segments.

The speed setting for the first segment will be shown in the flashing Current Segment column of the matrix. (The incline settings are not shown in the matrix.) The speed settings for the next three segments will be shown in the columns at the right.

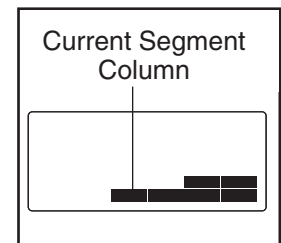

When only three seconds remain in the first segment of the program, both the Current Segment column and the column to the right will flash, and a series of tones will sound. If the speed and/or incline of the treadmill is about to change, the Incline display and/or the Speed display will flash to alert you. When the first segment ends, *all speed settings in the matrix will move one column to the left*. The speed setting for the second segment will then be shown in the flashing Current Segment column, and the treadmill will automatically adjust to the speed and incline settings for the second segment. Note: If all of the indicators in the Current Segment column are lit after the speed settings have moved to the left, *the speed settings may move downward* so that only the highest indicators appear in the matrix. If some indicators in the Current Segment column are not lit when the speed settings move to the left again, the speed settings will move back up.

The program will continue in this way until the speed setting for the last segment is shown in the Current Segment column and the last segment ends. The walking belt will then slow to a stop.

If the speed or incline setting is too high or too low at any time during the program, you can manually override the setting by pressing the Speed or Incline buttons. Every few times a Speed button is pressed, an additional indicator will appear or disappear in the Current Segment column. (If any of the columns to the right of the Current Segment column have the same number of indicators as the

Current Segment column, an additional indicator may appear or disappear in those columns as well.) **Note: When the next segment of the program begins, the treadmill will automatically adjust to the speed and incline settings for the next segment.**

To stop the program at any time, press the Stop button. The Time/Pace display will begin to flash. To restart the program, press the Start button or the Speed increase button. The walking belt will begin to move at 1 mph. When the next segment of the program begins, the treadmill will automatically adjust to the speed and incline settings for the next segment.

**4 Follow your progress with the track and the displays.**

See step 5 on page 12.

**5 Measure your heart rate if desired.**

See step 6 on page 13.

**6 Listen to the radio if desired.**

See step 7 on page 14.

**7 When you are finished exercising, remove the key.**

See step 8 on page 14.



# HOW TO FOLD AND MOVE THE TREADMILL

## HOW TO FOLD THE TREADMILL FOR STORAGE

Before folding the treadmill, adjust the incline to the lowest position. If this is not done, the treadmill may be permanently damaged. Next, unplug the power cord. **CAUTION:** You must be able to safely lift 20 kg (45 lbs.) to raise, lower, or move the treadmill.

1. Hold the treadmill with your hands in the location shown by the arrow at the right. **To decrease the possibility of injury, bend your legs and keep your back straight. As you raise the frame, make sure to lift with your legs rather than your back.** Raise the frame halfway to the vertical position.

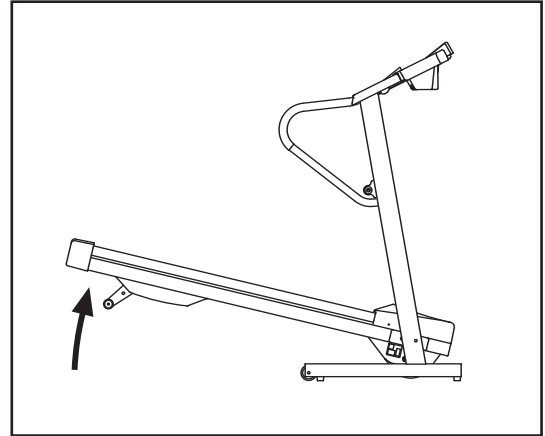

2. Move your right hand to the position shown and hold the treadmill firmly. Using your left hand, pull the latch knob to the left and hold it. Raise the frame until it is past the latch pin. Then, slowly release the latch knob. **Make sure that the frame is securely held by the latch pin.**

**To protect the floor or carpet from damage, place a mat under the treadmill. Keep the treadmill out of direct sunlight. Do not leave the treadmill in the storage position in temperatures above 30° C (85° F).**

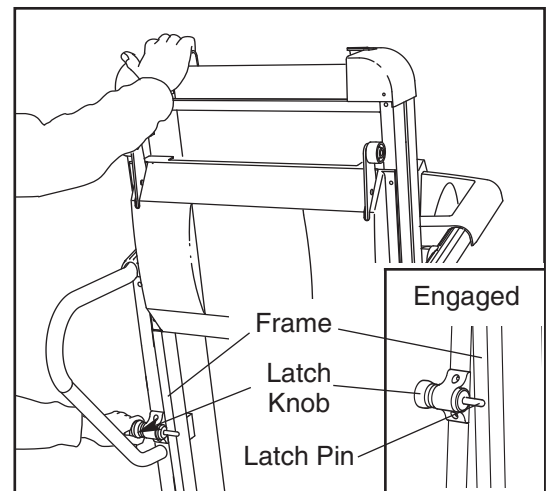

## HOW TO MOVE THE TREADMILL

Before moving the treadmill, convert the treadmill to the storage position as described above. **Make sure that the frame is securely held by the latch pin.**

1. Hold the handrails, and place one foot against one of the wheels. Tilt the treadmill back until it rolls on the wheels. Carefully move the treadmill to the desired location. **To reduce the risk of injury, use extreme caution while moving the treadmill. Do not move the treadmill over an uneven surface.**
2. Place one foot against one of the wheels, and carefully lower the treadmill to the storage position.

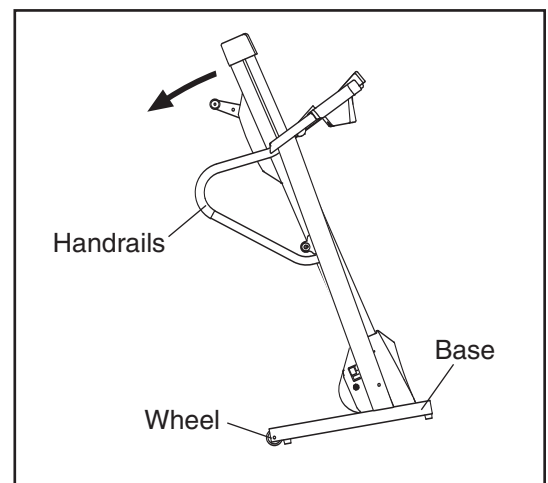

## HOW TO LOWER THE TREADMILL FOR USE

1. See drawing 2 above. Hold the upper end of the treadmill with your right hand. Pull the latch knob to the left and hold it. Pivot the frame down until it is past the latch pin. Then, slowly release the latch knob.
2. See drawing 1 above. Hold the frame firmly with both hands, and lower it to the floor. **Do not drop the frame to the floor. To decrease the possibility of injury, bend your legs and keep your back straight.**

# TROUBLESHOOTING

Most treadmill problems can be solved by following the steps below. Find the symptom that applies, and follow the steps listed. If further assistance is needed, please see the front cover of this manual.

## PROBLEM: The power does not turn on

**SOLUTION:** a. Make sure that the power cord is plugged into a properly earthed outlet (see page 10). If an extension cord is needed, use only a 3-conductor, 1mm<sup>2</sup> (14-gauge) cord that is no longer than 1.5 m (5 ft.). **IMPORTANT: The treadmill is not compatible with GFCI-equipped outlets.**

b. After the power cord has been plugged in, make sure that the key is fully inserted into the console.

c. Check the circuit breaker located on the treadmill near the power cord. If the switch protrudes as shown, the circuit breaker has tripped. To reset the circuit breaker, wait for five minutes and then press the switch back in.

d. Check the on/off switch located on the treadmill near the power cord. The switch must be in the "on" position.

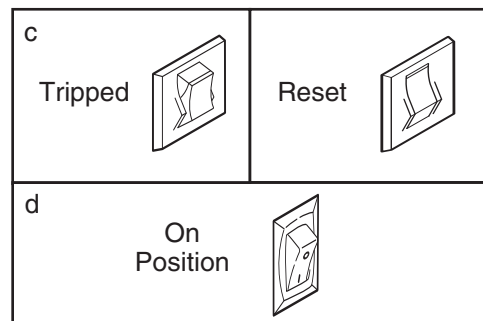

## PROBLEM: The power turns off during use

**SOLUTION:** a. Check the circuit breaker located on the treadmill near the power cord (see c. above). If the circuit breaker has tripped, wait for five minutes and then press the switch back in.

b. Make sure that the power cord is plugged in. If the power cord is plugged in, unplug it, wait for five minutes, and then plug it back in.

c. Remove the key from the console. Reinsert the key fully into the console.

d. Make sure that the on/off switch is in the "on" position (see d. above).

e. If the treadmill still will not run, please see the front cover of this manual.

## PROBLEM: The displays of the console do not function properly

**SOLUTION:** a. Remove the key from the console and **UNPLUG THE POWER CORD**. Remove the four 3/4" Tek Screws (9) from the Hood (1), and carefully remove the Hood.

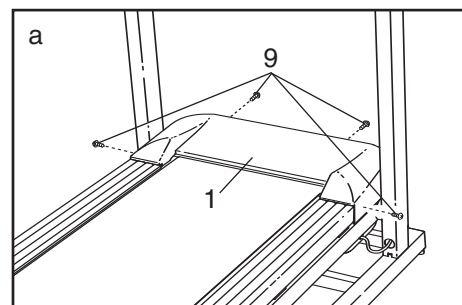

Locate the Reed Switch (16) and the Magnet (10) on the left side of the Pulley (101). Turn the Pulley until the Magnet is aligned with the Reed Switch. **Make sure that the gap between the Magnet and the Reed Switch is about 3 mm (1/8 in.).** If necessary, loosen the indicated 3/4" Tek Screws (9), move the Reed Switch slightly, and then retighten the Screw. Reattach the Hood (not shown), and run the treadmill for a few minutes to check for a correct speed reading.

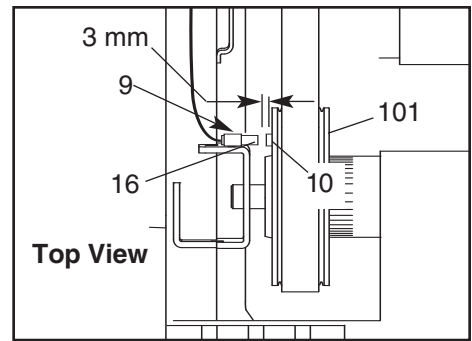

**PROBLEM: The walking belt slows when walked on**

**SOLUTION:** a. If an extension cord is needed, use only a 3-conductor, 1mm<sup>2</sup> (14-gauge) cord that is no longer than 1.5 m (5 ft.).

b. If the walking belt is overtightened, treadmill performance may decrease and the walking belt may become damaged. Remove the key and **UNPLUG THE POWER CORD**. Using the hex key, turn both rear roller bolts counterclockwise, 1/4 of a turn. When the walking belt is properly tightened, you should be able to lift each edge of the walking belt 8 to 10 cm (3 to 4 in.) off the walking platform. Be careful to keep the walking belt centred. Then, plug in the power cord, insert the key, and run the treadmill for a few minutes. Repeat until the walking belt is properly tightened.

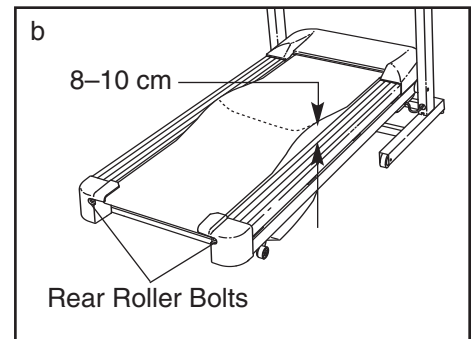

c. If the walking belt still slows when walked on, please see the front cover of this manual.

**PROBLEM: The walking belt is off-centre or slips when walked on**

**SOLUTION:** a. If the walking belt is off-centre, remove the key and **UNPLUG THE POWER CORD**. **If the walking belt has shifted to the left**, use the hex key to turn the left rear roller bolt clockwise 1/2 of a turn; **if the walking belt has shifted to the right**, turn the left rear roller bolt counterclockwise 1/2 of a turn. Be careful not to overtighten the walking belt. Then, plug in the power cord, insert the key, and run the treadmill for a few minutes. Repeat until the walking belt is centred.

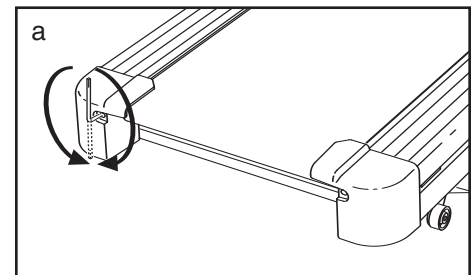

b. If the walking belt slips when walked on, first remove the key and **UNPLUG THE POWER CORD**. Using the hex key, turn both rear roller bolts clockwise, 1/4 of a turn. When the walking belt is correctly tightened, you should be able to lift each edge of the walking belt 8 to 10 cm (3 to 4 in.) off the walking platform. Be careful to keep the walking belt centred. Then, plug in the power cord, insert the key, and walk on the treadmill for a few minutes. Repeat until the walking belt is properly tightened.

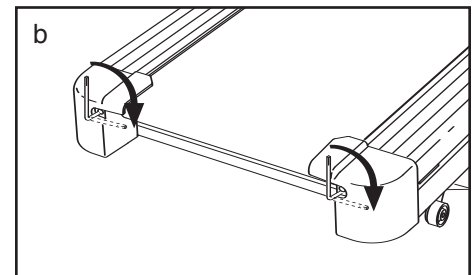

# CONDITIONING GUIDELINES

**⚠️ WARNING:** Before beginning this or any exercise program, consult your physician. This is especially important for individuals over the age of 35 or individuals with pre-existing health problems.

The pulse sensor is not a medical device. Various factors, including the user's movement, may affect the accuracy of heart rate readings. The pulse sensor is intended only as an exercise aid in determining heart rate trends in general.

The following guidelines will help you to plan your exercise program. For more detailed exercise information, obtain a reputable book or consult your physician.

## EXERCISE INTENSITY

Whether your goal is to burn fat or to strengthen your cardiovascular system, the key to achieving the desired results is to exercise with the proper intensity. The proper intensity level can be found by using your heart rate as a guide. The chart below shows recommended heart rates for fat burning and aerobic exercise.

	♥	165	155	145	140	130	125	115
♥		145	138	130	125	118	110	103
♥		125	120	115	110	105	95	90
		20	30	40	50	60	70	80

To find the proper heart rate for you, first find your age near the bottom of the chart (ages are rounded off to the nearest ten years). Next, find the three numbers above your age. The three numbers define your "training zone." The lower two numbers are recommended heart rates for fat burning; the higher number is the recommended heart rate for aerobic exercise.

## Fat Burning

To burn fat effectively, you must exercise at a relatively low intensity level for a sustained period of time. During the first few minutes of exercise, your body uses easily accessible *carbohydrate calories* for energy. Only after the first few minutes does your body begin to use stored *fat calories* for energy. If your goal

is to burn fat, adjust the speed and incline of the treadmill until your heart rate is near the lowest number in your training zone.

For maximum fat burning, adjust the speed and incline of the treadmill until your heart rate is near the middle number in your training zone.

## Aerobic Exercise

If your goal is to strengthen your cardiovascular system, your exercise must be "aerobic." Aerobic exercise is activity that requires large amounts of oxygen for prolonged periods of time. This increases the demand on the heart to pump blood to the muscles, and on the lungs to oxygenate the blood. For aerobic exercise, adjust the speed and incline of the treadmill until your heart rate is near the highest number in your training zone.

## WORKOUT GUIDELINES

Each workout should include the following three parts:

**A Warm-up**—Start each workout with 5 to 10 minutes of stretching and light exercise. A proper warm-up increases your body temperature, heart rate and circulation in preparation for exercise.

**Training Zone Exercise**—After warming up, increase the intensity of your exercise until your pulse is in your training zone for 20 to 60 minutes. (During the first few weeks of your exercise program, do not keep your pulse in your training zone for longer than 20 minutes.) Breathe regularly and deeply as you exercise—never hold your breath.

**A Cool-down**—Finish each workout with 5 to 10 minutes of stretching to cool down. This will increase the flexibility of your muscles and will help prevent post-exercise problems.

## EXERCISE FREQUENCY

To maintain or improve your condition, complete three workouts each week, with at least one day of rest between workouts. After a few months, you may complete up to five workouts each week if desired. The key to success is to make exercise a regular and enjoyable part of your everyday life.

# PART IDENTIFICATION CHART

Remove this chart and use it to identify small parts during assembly. Save this chart and the EXPLODED DRAWING/PART LIST for future reference.

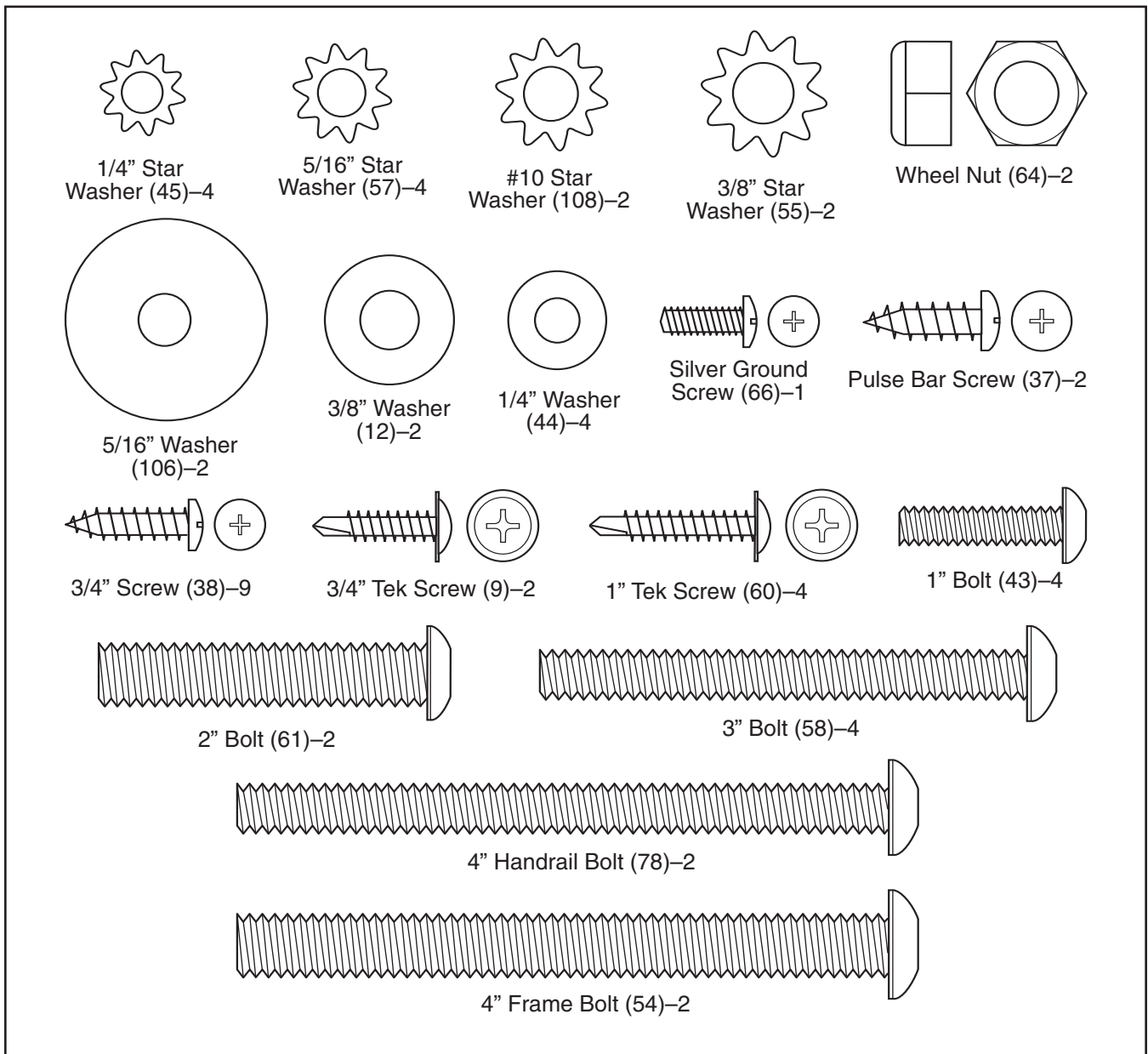

# PART LIST—Model No. WATL27205.1

R1105A

Key No.	Qty.	Description	Key No.	Qty.	Description	Key No.	Qty.	Description
1	1	Hood	43	4	1" Bolt	86	2	Frame U-nut
2	4	#8 Washer	44	13	1/4" Washer	87	1	8" Cable Tie
3	2	Foot Rail	45	4	1/4" Star Washer	88	1	Incline Stop Bracket
4	2	Belt Guide	46	1	Latch Housing	89	2	Rear Wheel Bolt
5	4	1/2" Screw	47	1	Left Upright	90	4	Incline Leg Nut
6	4	Isolator	48	2	Ground Bolt	91	2	Rear Wheel
7	4	Platform Screw	49	2	Pulse Bar Screw	92	4	Plastic Fastener
8	2	Rubber Hood Mount	50	2	Rear Platform Screw	93	1	Right Endcap
9	24	3/4" Tek Screw	51	1	Motor Bracket	94	3	Roller Star Washer
10	1	Magnet	52	1	Motor Isolator	95	2	Roller Adj. Bolt
11	1	Reed Switch Clip	53	1	Latch Pin Assembly	96	1	Frame
12	2	3/8" Washer	54	2	4" Frame Bolt	97	1	Rear Roller
13	1	Left Handrail	55	2	3/8" Star Washer	98	1	Left Endcap
14	2	Motor Bushing	56	2	Motor Bolt	99	1	Walking Belt
15	1	Motor Pivot Nut	57	4	5/16" Star Washer	100	1	Walking Platform
16	1	Reed Switch	58	4	3" Bolt	101	1	Front Roller/Pulley
17	1	Drive Motor	59	2	Upright Spacer	102	1	Warning Decal
18	1	Pulley/Flywheel/Fan	60	4	1" Tek Screw	103	1	Front Roller Adj. Bolt
19	1	Drive Motor Belt	61	2	2" Bolt	104	1	Right Upright
20	4	Bracket Grommet	62	2	Base Endcap	105	1	Pulse Sensor
21	3	Motor Tension Bolt/ Upper Incline Bolt	63	2	Wheel			Assembly
22	1	Motor Tension Star Washer	64	4	Wheel Nut	106	2	5/16" Washer
23	1	Motor Fan	65	1	Wire Harness	107	1	5/32" Hex Key
24	2	Motor Tension Nut	66	1	Silver Ground Screw	108	2	#10 Star Washer
25	1	Motor Pivot Bolt	67	1	Console Base	109	2	Incline Pivot Bolt
26	1	Electronics Bracket	68	1	Book Lens	110	1	Belly Pan Cap
27	14	Electronics Screw	69	1	Console	111	1	Rear Belly Pan
28	1	Filter	70	1	Plastic Tie	112	1	Lower Incline Bolt
29	1	Receptical	71	1	Key Clip	113	1	Photo Switch Wire
30	1	Circuit Breaker	72	1	Console Warning Decal	114	1	Photo Switch
31	1	On/Off Switch				#	1	10" Green Wire, F/Ring
32	1	Controller	73	4	Base Pad	#	1	8" Green Wire, F/Ring
33	1	Incline Leg	74	4	U-nut	#	1	4" Green Wire, F/Ring
34	1	Transformer	75	1	Incline Wire	#	1	12" Blue Wire, 2F
35	2	Ground Nut	76	2	Frame Plug	#	1	6" Blue Wire, M/F
36	2	Handrail Foam	77	1	Frame Ground Wire	#	1	8" Blue Wire, 2F
37	2	Pulse Bar Screw	78	2	4" Handrail Bolt	#	1	8" White Wire, 2F
38	25	3/4" Screw	79	1	Base	#	1	6" Black Wire, M/F
39	1	Pulse Bar	80	1	Optic Switch	#	2	4" Black Wire, 2F
40	1	Right Handrail	81	1	Belly Pan	#	1	8" Red Wire, M/F
41	1	Hex Key	82	1	Incline Motor	#	1	User's Manual
42	4	Cage Nut	83	1	Power Cord			
			84	1	Access Door			#These parts are not illustrated
			85	4	Cable Tie Clamp			



# EXPLODED DRAWING—Model No. WATL27205.1

R1105A

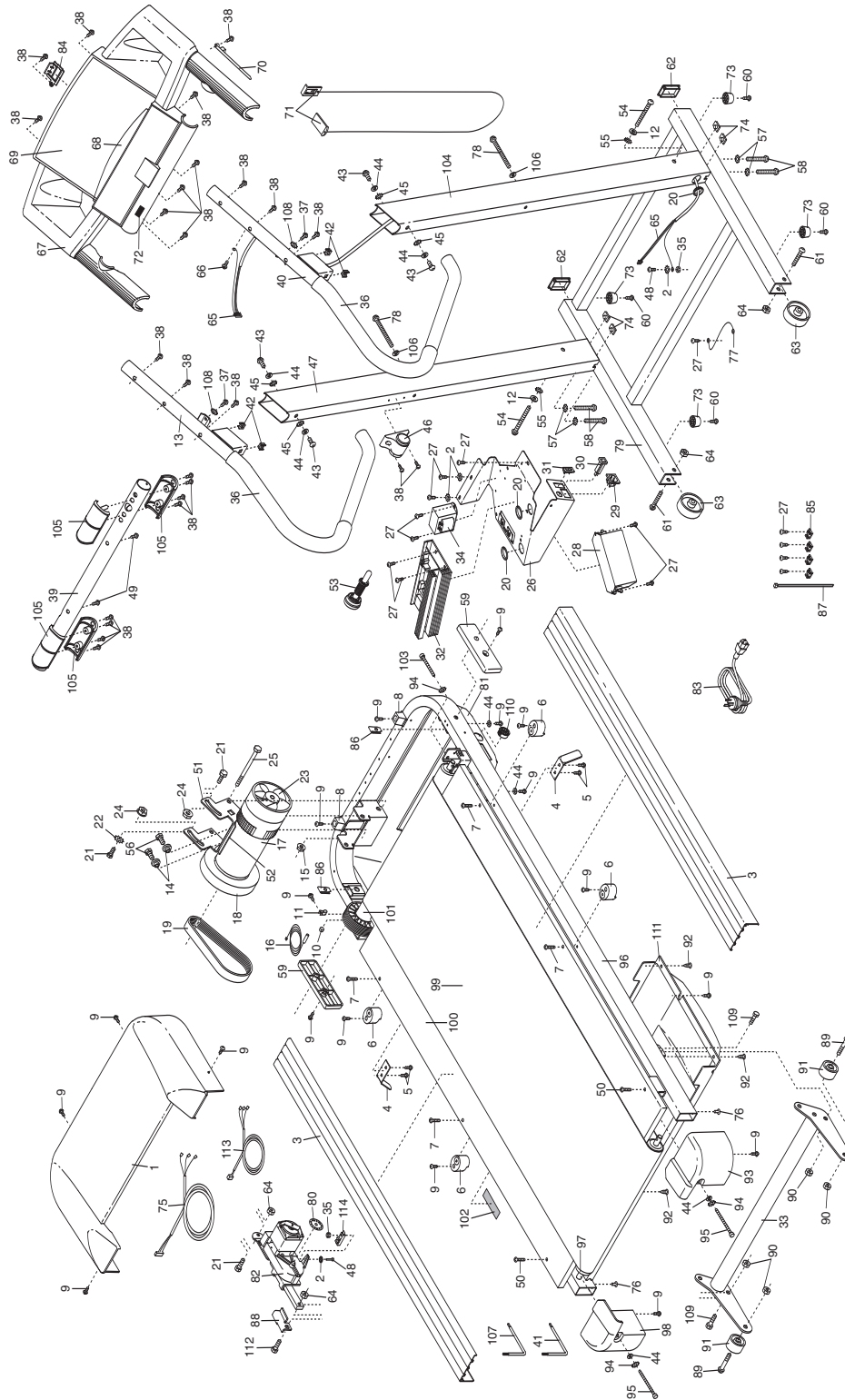



# HOW TO ORDER REPLACEMENT PARTS

To order replacement parts, contact our Customer Service Department or write:

Shanghai Newlife Fitness Equipment, Inc.  
Customer Service Department  
Room 504, No. 16, Lane 1030  
YanAn West Road  
Shanghai, 200052, PR China

Tel: **800-820-0915**

Before calling, please note the following information:

- the MODEL NUMBER of the product (WATL27205.1)
- the NAME of the product (WESLO E-30 treadmill)
- the SERIAL NUMBER of the product (see the front cover of this manual)
- the KEY NUMBER AND DESCRIPTION OF THE PART(S) (see the EXPLODED DRAWING and the PART LIST attached in the centre of this manual)

## LIMITED WARRANTY

Shanghai Newlife Fitness Equipment, Inc. (Newlife), warrants this product to be free from defects in workmanship and material under normal use and service conditions. The drive motor is warranted for five (5) years after the date of purchase. Parts and labor are warranted for one (1) year after the date of purchase.

This warranty extends only to the original purchaser. Newlife's obligation under this warranty is limited to replacing or repairing, at Newlife's option, the product through one of its authorized service centers. All repairs for which warranty claims are made must be pre-authorized by Newlife. This warranty does not extend to any product or damage to a product caused by or attributable to freight damage, abuse, misuse, improper or abnormal usage or repairs not provided by an Newlife authorized service center; products used for commercial or rental purposes; or products used as store display models. No other warranty beyond that specifically set forth above is authorized by Newlife.

Newlife is not responsible or liable for indirect, special or consequential damages arising out of or in connection with the use or performance of the product or damages with respect to any economic loss, loss of property, loss of revenues or profits, loss of enjoyment or use, costs of removal or installation or other consequential damages of whatsoever nature. Some states do not allow the exclusion or limitation of incidental or consequential damages. Accordingly, the above limitation may not apply to you.

The warranty extended hereunder is in lieu of any and all other warranties and any implied warranties of merchantability or fitness for a particular purpose is limited in its scope and duration to the terms set forth herein. Some states do not allow limitations on how long an implied warranty lasts. Accordingly, the above limitation may not apply to you.

This warranty gives you specific legal rights. You may also have other rights which vary from state to state.

**Shanghai Newlife Fitness Equipment, Inc.**

## Free Manuals Download Website

<http://myh66.com>

<http://usermanuals.us>

<http://www.somanuals.com>

<http://www.4manuals.cc>

<http://www.manual-lib.com>

<http://www.404manual.com>

<http://www.luxmanual.com>

<http://aubethermostatmanual.com>

Golf course search by state

<http://golfingnear.com>

Email search by domain

<http://emailbydomain.com>

Auto manuals search

<http://auto.somanuals.com>

TV manuals search

<http://tv.somanuals.com>