

# WESLO<sup>®</sup> CADENCE 840

Model No. WCTL84091

Serial No. \_\_\_\_\_

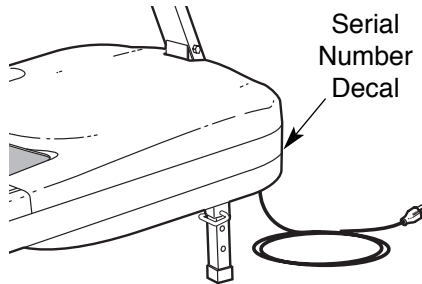

## USER'S MANUAL

### QUESTIONS?

As a manufacturer, we are committed to providing complete customer satisfaction. If you have questions, or if there are missing parts, please call:

**1-888-936-4266**

Mon.–Fri. 8h00 until 18h30 EST  
(excluding holidays).



### CAUTION

Read all precautions and instructions in this manual before using this equipment. Save this manual for future reference.



Visit our website at

[www.weslo.com](http://www.weslo.com)

# WESLO<sup>®</sup> CADENCE 840

---

## TABLE OF CONTENTS

IMPORTANT PRECAUTIONS .....	.3
BEFORE YOU BEGIN .....	.5
ASSEMBLY .....	.6
OPERATION AND ADJUSTMENT .....	.8
TROUBLESHOOTING AND MAINTENANCE .....	.11
STORAGE .....	.13
CONDITIONING GUIDELINES .....	.14
PART LIST .....	.16
EXPLODED DRAWING .....	.17
CUSTOMER RECORD .....	.18
ORDERING REPLACEMENT PARTS .....	.19
LIMITED WARRANTY .....	.20

# IMPORTANT PRECAUTIONS

**⚠ WARNING:** To reduce the risk of burns, fire, electric shock or injury to persons, read the following important precautions and information before operating the treadmill.

1. It is the responsibility of the owner to ensure that all users of this treadmill are adequately informed of all warnings and precautions.
2. Use the treadmill only as described in this manual.
3. Place the treadmill on a level surface, with at least 2.5 m (8 ft.) of clearance behind it and 0.5 m (2 ft.) on each side. Do not place the treadmill on any surface that blocks air openings. To protect the floor or carpet from damage, place a mat under the treadmill.
4. Keep the treadmill indoors, away from moisture and dust. Do not put the treadmill in a garage or covered patio, or near water.
5. Do not operate the treadmill where aerosol products are used or where oxygen is being administered.
6. The roller guards should be 32mm (1/8 in.) from the rear roller. Adjust the position of the roller guards, if necessary. (The drawing on page 5 shows the location of the roller guards.)
7. Keep children under 12 and pets away from the treadmill at all times.
8. The treadmill should not be used by persons weighing more than 115 kg (250 lbs.). Never allow more than one person on the treadmill at a time.
9. When connecting the power cord (see page 7), plug the power cord into a surge suppressor (not included) and plug the surge suppressor into a grounded circuit capable of carrying 15 or more amps. No other appliance should be on the same circuit. Do not use an extension cord.
10. Use only a CUL-listed surge suppressor of 450 joules minimum surge dissipation with voltage rating of 400 volts or less, rated at 15 amps, with a 1 mm<sup>2</sup> (14-gauge) cord of 1.5 m (5 ft.) or less in length. Do not use an extension cord.
11. Failure to use a properly functioning surge suppressor could result in damage to the control system of the treadmill. If the control system is damaged, the walking belt may change speed or stop unexpectedly, which may result in a fall and serious injury.
12. Keep the power cord and the surge suppressor away from heated surfaces.
13. Never move the walking belt while the power is turned off. Do not operate the treadmill if the power cord or plug is damaged, or if the treadmill is not working properly. (See **BEFORE YOU BEGIN** on page 5 if the treadmill is not working properly.)
14. Wear appropriate exercise attire when using the treadmill. Do not wear loose clothing that could become caught in the treadmill. Athletic support clothes are recommended for both men and women. Always wear athletic shoes. Never use the treadmill with bare feet, wearing only stockings, or in sandals.
15. Never start the treadmill while you are standing on the walking belt. Always hold the handrails while exercising on the treadmill.
16. The pulse sensor is not a medical device. Various factors, including the user's movement, may affect the accuracy of heart rate readings. The pulse sensor is intended only as an exercise aid in determining heart rate trends in general.
17. Adjust the speed in small increments.
18. Never leave the treadmill unattended while it is running. Always remove the key when the treadmill is not in use.
19. To change the incline level of the treadmill, refer to the instructions on page 10. Do not use the treadmill with the incline pins removed.

20. Inspect and properly tighten all parts of the treadmill every three months.
21. Never drop or insert any object into any opening.
22. Always unplug the power cord before performing the maintenance and adjustment procedures described in this manual. Never remove the motor hood unless instructed to

do so by an authorized service representative. Servicing other than the procedures in this manual should be performed by an authorized service representative only.

23. This treadmill is intended for in-home use only. Do not use this treadmill in any commercial, rental, or institutional setting.

## SAVE THESE INSTRUCTIONS

**⚠ WARNING:** Before beginning this or any exercise program, consult your physician. This is especially important for persons over the age of 35 or persons with pre-existing health problems. Read all instructions before using. ICON assumes no responsibility for personal injury or property damage sustained by or through the use of this product.

The decal shown at the right has been placed on the water bottle holder of the treadmill.

If the decal is missing, or if it is not legible, please call our Customer Service Department, toll-free, to order a free replacement decal (see **ORDERING REPLACEMENT PARTS** on page 19). Apply the decal in the location shown.

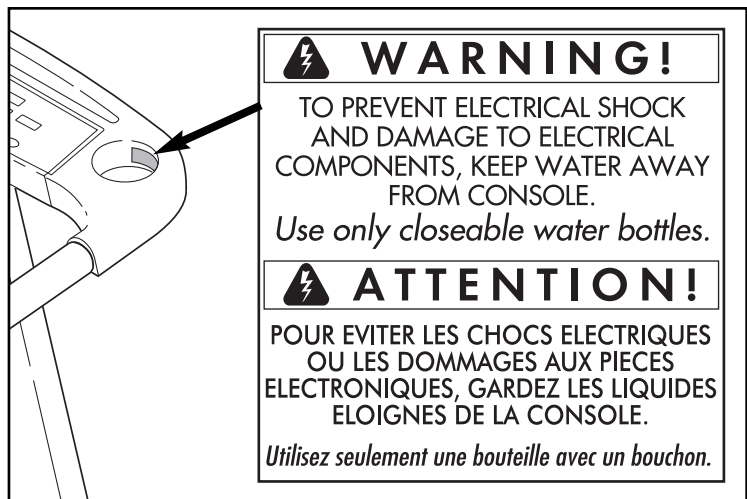

# BEFORE YOU BEGIN

Thank you for selecting the WESLO® CADENCE 840 treadmill. The CADENCE 840 treadmill blends advanced technology with innovative design to offer you an excellent form of cardiovascular exercise, in the convenience and privacy of your home.

**For your benefit, read this manual carefully before using the treadmill.** If you have additional questions, please call our Customer Service Department toll-free at **1-888-936-4266**, Monday through Friday, 8h00 until

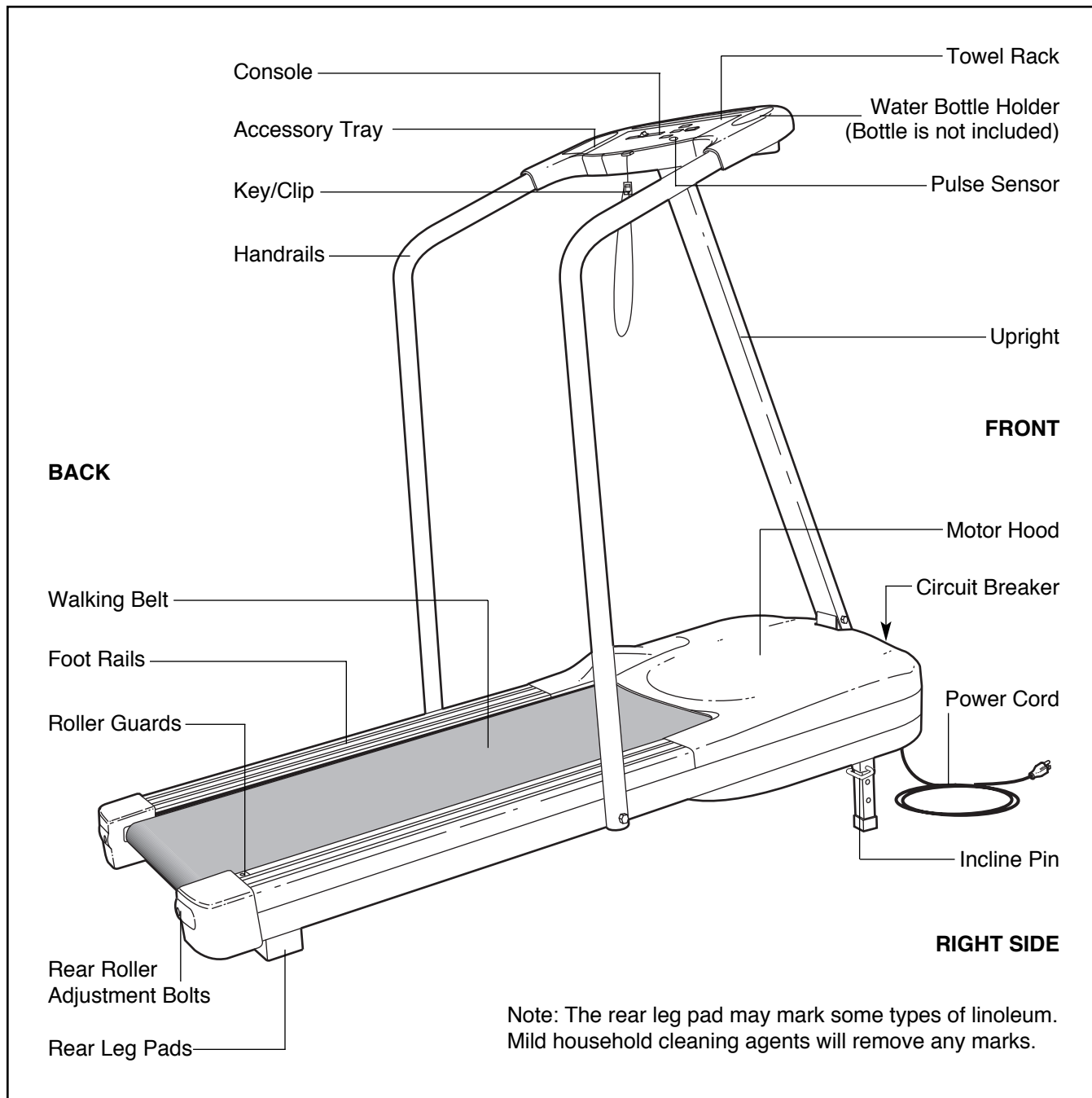

18h00 Eastern Time (excluding holidays). To help us assist you, please note the product model number and serial number before calling. The model number of the treadmill is WCTL84091. The serial number can be found on a decal attached to the treadmill (see the front cover of this manual for the location).

Before reading further, please review the drawing below and familiarize yourself with the parts that are labeled.



# ASSEMBLY

Set the treadmill in a cleared area and remove all packing materials. Do not dispose of the packing materials until assembly is completed. Refer to the drawings below to identify the small parts used in assembly.

Assembly requires a standard screwdriver  and an adjustable wrench  (not included).

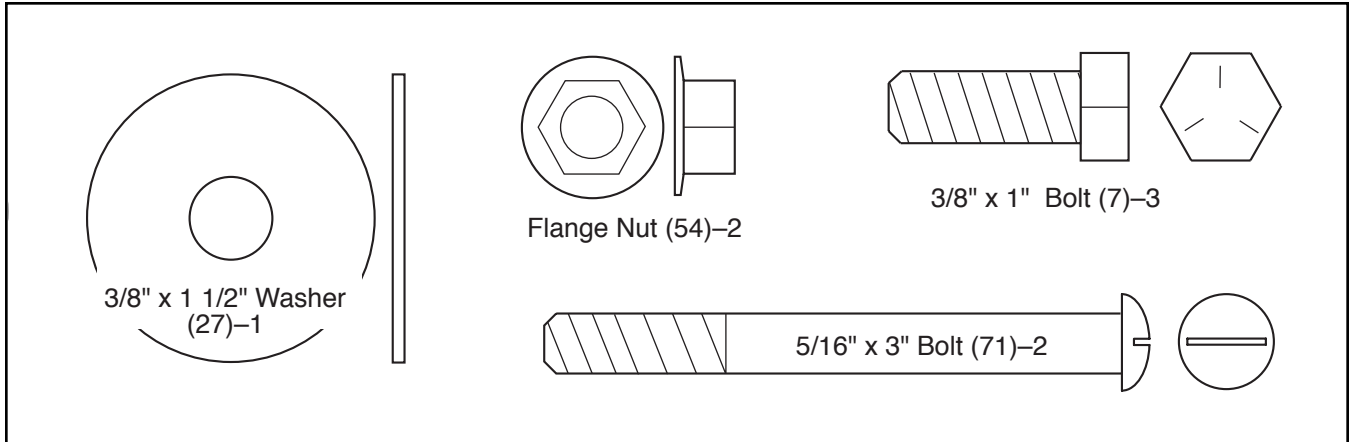

1. Raise the Upright (20) to the vertical position. Slide the 3/8" x 1 1/2" Washer (27) onto a 3/8" x 1" Bolt (7). Insert the Bolt into the lower end of the Upright. Finger tighten the Bolt into the Frame (46).

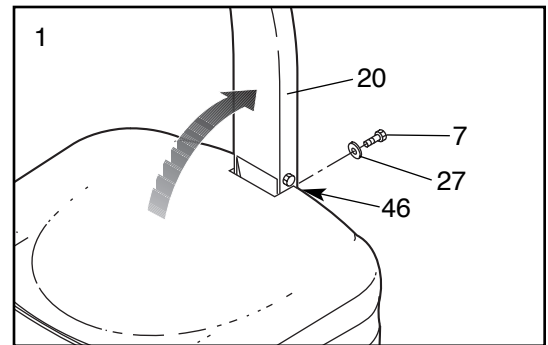

2. If there are plastic ties in the upper ends of the Handrails (1), cut them off. Insert the upper end of one of the Handrails into the Console Housing (4). (Note: The two Handrails are identical. Due to the manufacturing process, there is a dimple near the lower end of each Handrail. It makes no difference which side the dimple is on when the Handrails are assembled.) Finger tighten a 3/8" x 1" Bolt (7) into the plate under the Console Housing (4) and into the Handrail.

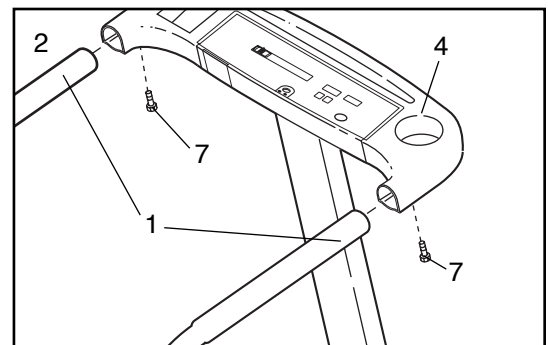

Attach the other Handrail (1) in the same manner.

3. Insert a 5/16" x 3" Bolt (71) into the lower end of the right Handrail (1) and the Frame (46). Reach under the Frame and tighten a Flange Nut (54) onto the Bolt.

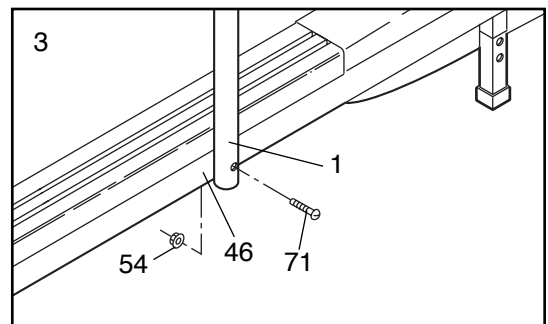

Attach the other Handrail (not shown) in the same manner. **Tighten all Bolts used in steps 1 through 3.**

- Remove the paper backing from the Adhesive Clip (16). Press the Adhesive Clip onto the Right Endcap (45) in the indicated location. Press the Allen Wrench (41) into the Adhesive Clip.

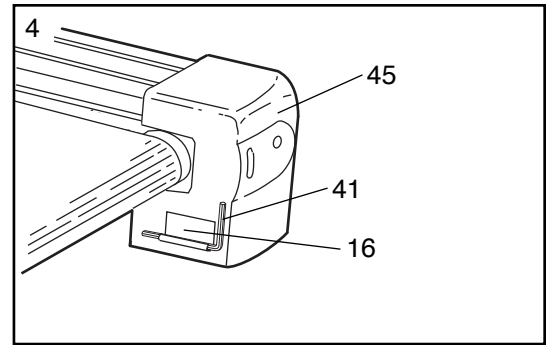

- The Console (5) requires three "AA" batteries (not included); alkaline batteries are recommended.**

Slide up the Battery Cover (36). Press three batteries into the battery compartment, with the negative (–) ends of the batteries touching the springs. Close the Battery Cover.

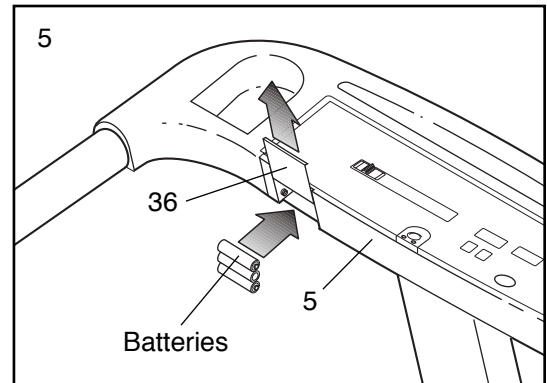

- Make sure that all parts are tightened before you use the treadmill. To protect the floor or carpet from damage, place a mat beneath the treadmill.

# OPERATION AND ADJUSTMENT

## THE PERFORMANT LUBE™ WALKING BELT

Your treadmill features a walking belt coated with PERFORMANT LUBE™, a high-performance lubricant.

**IMPORTANT:** Never apply silicone spray or other substances to the walking belt or the walking platform. Such substances will deteriorate the walking belt and cause excessive wear.

## HOW TO PLUG IN THE POWER CORD

**⚠ DANGER:** Improper connection of the equipment-grounding conductor can result in an increased risk of electric shock. Check with a qualified electrician or serviceman if you are in doubt as to whether the product is properly grounded. Do not modify the plug provided with the product—if it will not fit the outlet, have a proper outlet installed by a qualified electrician.

Your treadmill, like any other type of sophisticated electronic equipment, can be seriously damaged by sudden voltage changes in your home's power. Voltage surges, spikes, and noise interference can result from weather conditions or from other appliances being turned on or off. **To decrease the possibility of your treadmill being damaged, always use a surge suppressor with your treadmill (see drawing 1 at the right).**

**Use only a single-outlet surge suppressor that is UL 1449 listed as a transient voltage surge suppressor (TVSS). The surge suppressor must have a UL suppressed voltage rating of 400 volts or less and a minimum surge dissipation of 450 joules. The surge suppressor must be electrically rated for 120 volts AC and 15 amps. There must be a monitoring light on the surge suppressor to indicate whether it is functioning properly. Failure to use a properly functioning surge suppressor could result in damage to the control system of the treadmill. If the control system is damaged, the walking belt may change speed or stop unexpectedly, which may result in a fall and serious injury.**

**This product must be grounded.** If it should malfunction or break down, grounding provides a path of least resistance for electric current to reduce the risk of electric shock. This product is equipped with a cord having an equipment-grounding conductor and a grounding

plug. **Plug the power cord into a surge suppressor, and plug the surge suppressor into an appropriate outlet that is properly installed and grounded in accordance with all local codes and ordinances. Important: The treadmill is not compatible with GFCI-equipped outlets.**

This product is for use on a nominal 120-volt circuit, and has a grounding plug that looks like the plug illustrated in drawing 1 below. A temporary adapter that looks like the adapter illustrated in drawing 2 may be used to connect the surge suppressor to a 2-pole receptacle as shown in drawing 2 if a properly grounded outlet is not available.

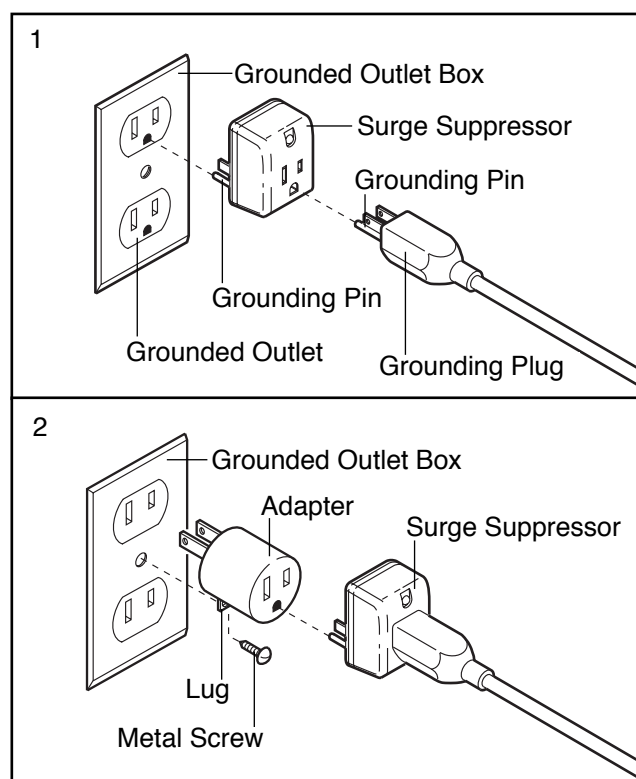

The temporary adapter should be used only until a properly grounded outlet (drawing 1) can be installed by a qualified electrician.

The green-colored rigid ear, lug, or the like extending from the adapter must be connected to a permanent ground such as a properly grounded outlet box cover. Whenever the adapter is used it must be held in place by a metal screw. **Some 2-pole receptacle outlet box covers are not grounded. Contact a qualified electrician to determine if the outlet box cover is grounded before using an adapter.**



## DIAGRAM OF THE CONSOLE

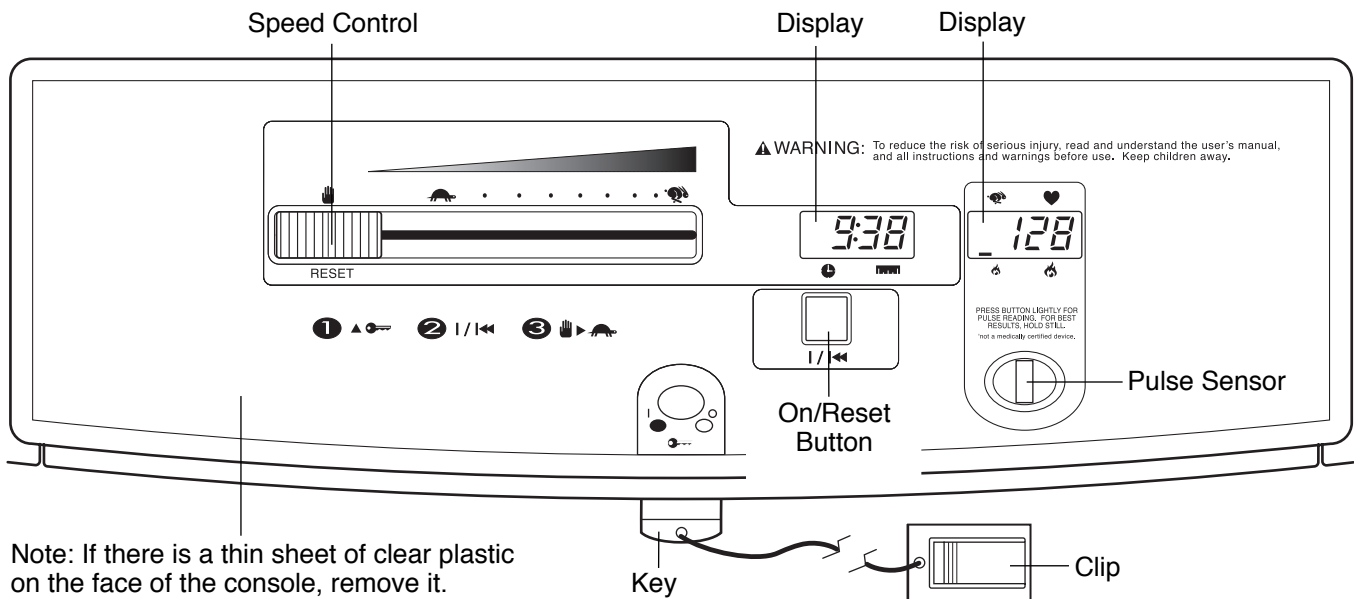

**CAUTION:** Before operating the console, read the following important precautions.

- Do not stand on the walking belt when turning on the power.
- Always wear the clip while operating the treadmill. When the key is removed from the console, the power will shut off.
- After the speed control knob is moved, there will be a pause before the walking belt begins to move. Adjust the speed in small increments until you are familiar with the treadmill.
- To reduce the risk of electric shock, keep the console dry, avoid spilling liquids on the console, and use only a sealed water bottle.

### STEP BY STEP CONSOLE OPERATION

Before operating the console, make sure that the power cord is properly plugged in.

Next, step onto the foot rails of the treadmill. Find the clip attached to the key (see the drawing above), and slide the clip onto the waistband of your clothing.

Follow the steps at the right and on page 10 to operate the console.

#### 1 Insert the key fully into the power switch.

Note: The displays will not be activated when the key is first inserted, unless batteries were just installed.

#### 2 Press the on/reset button.

The two displays will be activated. Note: If batteries were just installed, the displays will already be activated.

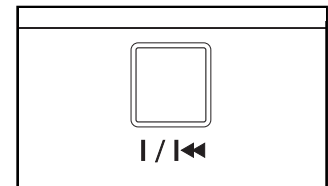

#### 3 Reset the speed control and start the walking belt.

Slide the speed control fully to the left, to the RESET position. Next, slide the control to the right until the walking belt begins to move at slow speed. Carefully step onto the walking belt and begin walking. Change the speed of the walking belt as desired by sliding the speed control.

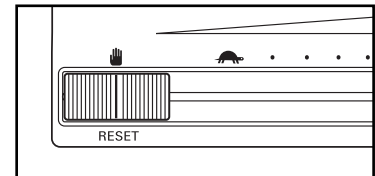

To stop the walking belt, slide the speed control to the RESET position.

#### 4 Monitor your progress with the two displays.

**Time/Distance display**—The left display shows the elapsed time and the distance that you have walked or run. Every few seconds, the display will change from one number to the other.

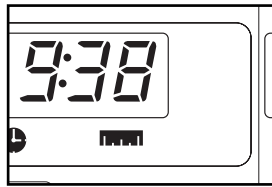

**Cals/Fat Cals/Speed/Pulse display**—The right display shows the approximate numbers of calories and fat calories you have burned (see FAT BURNING on page 14) and the speed of the walking belt. Every few seconds, the display will change from one number to the next. The left mode bar will appear when the number of calories is shown; the right mode bar will appear when the number of fat calories is shown. This display will also show your heart rate when the pulse sensor is used.

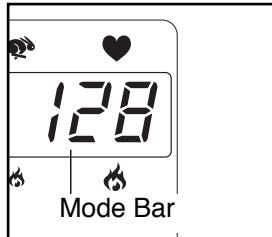

To reset the displays, press the on/reset button. Note: The displays can show distance and speed in kilometers or miles. To change from one measurement to the other, press and hold the on/reset button for approximately two seconds, until the entire display is temporarily lit.

#### 5 Measure your pulse, if desired.

To use the pulse sensor, stand on the foot rails and place your thumb on the pulse sensor as shown. The pulse sensor is pressure-activated—Fully press it down. **Do not press too hard, or the circulation in your thumb will be restricted, and your pulse will not be detected.** Next, slightly raise your thumb until the heart-shaped indicator in the pulse display flashes **steadily**. Hold your thumb at this level. After 5 to 10 seconds, your heart rate will be displayed.

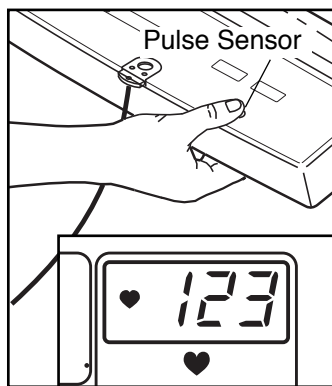

If an “H” (high) or an “L” (low) is displayed after 10 seconds, or if your heart rate is not displayed, lift your thumb off the sensor and allow the display to reset. Press down again on the sensor as described above. Make sure that your thumb is positioned as shown, and that you are applying the proper amount of pressure to the sensor. Try the sensor several times until you become familiar with it. Remember to stand still while measuring your pulse.

#### 6 When you are finished exercising, stop the walking belt and remove the key.

Step onto the foot rails, slide the speed control to the Reset position, and remove the key from the console. The displays will turn off a few minutes after the key is removed. **Note: Any time that the walking belt is stopped for a few minutes, the displays will automatically turn off to conserve the batteries.**

#### HOW TO CHANGE THE INCLINE

To vary the intensity of your exercise, the incline of the treadmill can be changed. There are three different incline settings. **Before changing the incline, remove the key and unplug the power cord.**

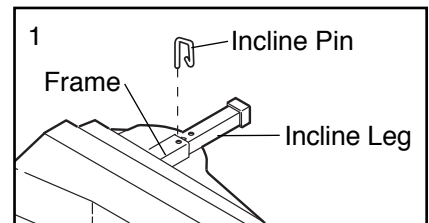

To change the incline, carefully lay the treadmill on its left side. Remove the incline pin from the right incline leg as shown in drawing 1. Adjust the incline leg to the desired height and fully re-insert the incline pin. Make sure the incline pin is in the “locked” position shown in drawing 2. Lay the treadmill on its right side. Repeat the procedure for the left incline leg. **CAUTION: Before using the treadmill, make sure that both incline pins are fully inserted at the same height. Do not use the treadmill with the incline pins removed.**

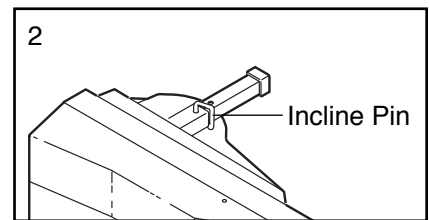

# TROUBLESHOOTING AND MAINTENANCE

Most treadmill problems can be solved by following the simple steps below. Find the symptom that applies to your treadmill and follow the steps listed. If further assistance is needed, please call our Customer Service Department at 1-888-936-4266, Monday through Friday, 8 a.m. until 6:30 p.m. Eastern Standard Time (excluding holidays).

## 1. SYMPTOM: THE POWER DOES NOT TURN ON

- Make sure that the power cord is plugged into a surge suppressor, and that the surge suppressor is plugged into a properly grounded outlet (see page 8). Use only a CUL-listed surge suppressor, rated at 15 amps, with a 1 mm<sup>2</sup> (14-gauge) cord of 1.5 m (5 ft.) or less in length.
- After the power cord has been plugged in, make sure that the key is fully inserted into the console. (See page 8.)
- Check the circuit breaker located on the treadmill frame near the power cord. If the switch protrudes as shown, the circuit breaker has tripped. To reset the circuit breaker, wait for five minutes and then press the switch back in.

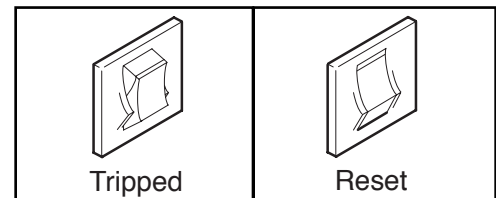

## 2. SYMPTOM: THE POWER TURNS OFF DURING USE

- Check the circuit breaker located on the treadmill frame near the power cord. If the circuit breaker has tripped, the switch will protrude. (See the drawing above.) To reset the circuit breaker, wait for five minutes and then press the switch back in.
- Make sure that the power cord is plugged in.
- Remove the key from the console. Reinsert the key fully into the console.

## 3. SYMPTOM: THE DISPLAYS OF THE CONSOLE DO NOT FUNCTION PROPERLY

- Check the batteries in the console. (See assembly step 5 on page 7). Most problems are the result of drained batteries.

## 4. SYMPTOM: THE WALKING BELT SLOWS WHEN WALKED ON

- Use only a single-outlet surge suppressor that meets all of the specifications described on page 8.
- If the walking belt is overtightened, treadmill performance may decrease and the walking belt may be permanently damaged. Remove the key and **UNPLUG THE POWER CORD**. Using the included allen wrench, turn both rear roller adjustment bolts counterclockwise, 1/4 of a turn. When the walking belt is properly tightened, you should be able to lift each side of the walking belt 5–7cm (2–3 in.) off the walking platform. The center of the walking belt should just touch the walking platform. Be careful to keep the walking belt centered. Plug in the power cord, insert the key and run the treadmill for a few minutes. Repeat until the walking belt is properly tightened.

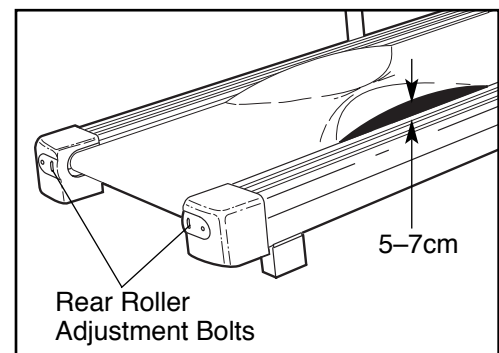

- If the walking belt still slows when walked on, please call our Customer Service Department.

## 5. SYMPTOM: THE WALKING BELT IS OFF-CENTER OR SLIPS WHEN WALKED ON

- a. **If the walking belt has shifted to the left**, first remove the key and **UNPLUG THE POWER CORD**. Using the allen wrench, turn the left rear roller adjustment bolt clockwise, and the right bolt counterclockwise, 1/4 of a turn each. Be careful not to overtighten the walking belt. Plug in the power cord, insert the key, and run the treadmill for a few minutes. Repeat until the walking belt is centered.

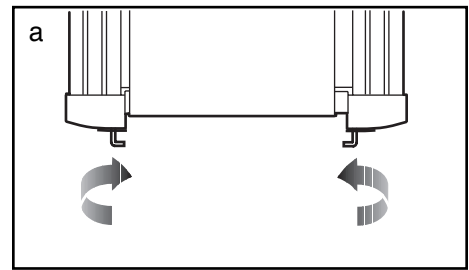

- b. **If the walking belt has shifted to the right**, first remove the key and **UNPLUG THE POWER CORD**. Using the allen wrench, turn the left rear roller adjustment bolt counterclockwise, and the right bolt clockwise, 1/4 of a turn each. Be careful not to overtighten the walking belt. Plug in the power cord, insert the key, and run the treadmill for a few minutes. Repeat until the walking belt is centered.

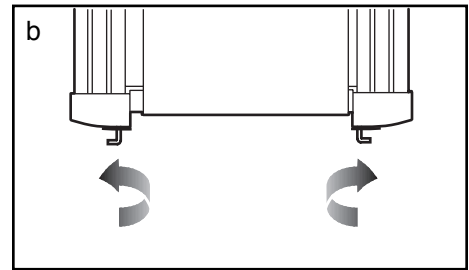

- c. **If the walking belt slips when walked on**, first remove the key and **UNPLUG THE POWER CORD**. Using the allen wrench, turn both rear roller adjustment bolts clockwise, 1/4 of a turn. When the walking belt is correctly tightened, you should be able to lift each side of the walking belt 5–7cm (2–3 in.) off the walking platform. The center of the walking belt should just touch the walking platform. Be careful to keep the walking belt centered. Plug in the power cord, insert the key, and run the treadmill for a few minutes. Repeat until the walking belt is properly tightened.

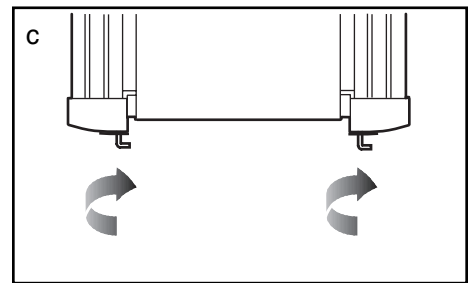

# STORAGE

Unplug the power cord when the treadmill is not in use.

Remove the bolt and nut from the lower end of each handrail.

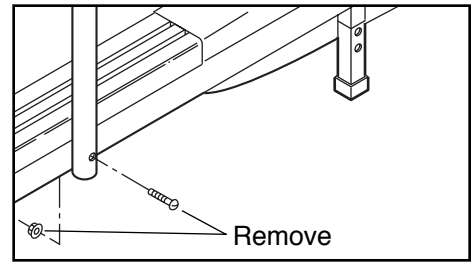

Remove the bolt from the upper end of each handrail. Slide the handrails out of the console housing.

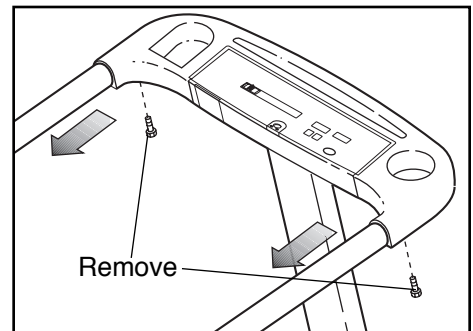

Remove the bolt and washer from the lower end of the upright. Lay the upright on the treadmill. Keep all hardware in a secure location.

It is recommended that the batteries be removed from the console and the treadmill be covered during extended periods of storage.

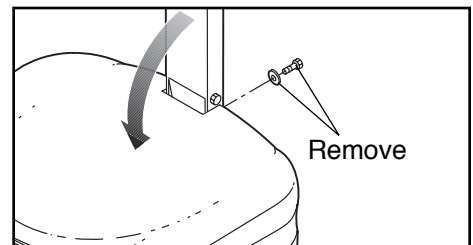

# CONDITIONING GUIDELINES

**⚠ WARNING:** Before beginning this or any exercise program, consult your physician. This is especially important for individuals over the age of 35 or individuals with pre-existing health problems.

The pulse sensor is not a medical device. Various factors, including your movement, may affect the accuracy of heart rate readings. The sensor is intended only as an exercise aid in determining heart rate trends in general.

The following guidelines will help you to plan your exercise program. For more detailed exercise information, obtain a reputable book or consult your physician.

## EXERCISE INTENSITY

Whether your goal is to burn fat or to strengthen your cardiovascular system, the key to achieving the desired results is to exercise with the proper intensity. The proper intensity level can be found by using your heart rate as a guide. The chart below shows recommended heart rates for fat burning and aerobic exercise.

HEART RATE TRAINING ZONES								
AEROBIC	165	155	145	140	130	125	115	
MAX FAT BURN	145	138	130	125	118	110	103	
FAT BURN	125	120	115	110	105	95	90	
	Age	20	30	40	50	60	70	80

To find the proper heart rate for you, first find your age near the bottom of the chart (ages are rounded off to the nearest ten years). Next, find the three numbers above your age. The three numbers define your “training zone.” The lower two numbers are recommended heart rates for fat burning; the higher number is the recommended heart rate for aerobic exercise.

To measure your heart rate during exercise, use the pulse sensor. If your heart rate is too high or too low, adjust the speed and incline of the treadmill.

## Fat Burning

To burn fat effectively, you must exercise at a relatively low intensity level for a sustained period of time. During the first few minutes of exercise, your body uses easily accessible carbohydrate calories for ener-

gy. Only after the first few minutes does your body begin to use stored fat calories for energy. If your goal is to burn fat, adjust the speed and incline of the treadmill until your heart rate is near the lowest number in your training zone.

For maximum fat burning, adjust the speed and incline of the treadmill until your heart rate is near the middle number in your training zone.

## Aerobic Exercise

If your goal is to strengthen your cardiovascular system, your exercise must be “aerobic.” Aerobic exercise is activity that requires large amounts of oxygen for prolonged periods of time. This increases the demand on the heart to pump blood to the muscles, and on the lungs to oxygenate the blood. For aerobic exercise, adjust the speed and incline of the treadmill until your heart rate is near the highest number in your training zone.

## WORKOUT GUIDELINES

Each workout should include the following three parts:

**A Warm-up**—Start each workout with 5 to 10 minutes of stretching and light exercise. A proper warm-up increases your body temperature, heart rate and circulation in preparation for exercise.

**Training Zone Exercise**—After warming up, increase the intensity of your exercise until your pulse is in your training zone for 20 to 60 minutes. (During the first few weeks of your exercise program, do not keep your pulse in your training zone for longer than 20 minutes.) Breathe regularly and deeply as you exercise—never hold your breath.

**A Cool-down**—Finish each workout with 5 to 10 minutes of stretching to cool down. This will increase the flexibility of your muscles and will help prevent post-exercise problems.

## EXERCISE FREQUENCY

To maintain or improve your condition, complete three workouts each week, with at least one day of rest between workouts. After a few months, you may complete up to five workouts each week if desired.

The key to success is to make exercise a regular and enjoyable part of your everyday life.

## SUGGESTED STRETCHES

The correct form for several basic stretches is shown in the drawings below. Move slowly as you stretch—never bounce.

### 1. Toe Touch Stretch

Stand with your knees bent slightly and slowly bend forward from your hips. Allow your back and shoulders to relax as you reach down toward your toes as far as possible. Hold for 15 counts, then relax. Repeat 3 times. Stretches: Hamstrings, back of knees and back.

### 2. Hamstring Stretch

Sit with one leg extended. Bring the sole of the opposite foot toward you and rest it against the inner thigh of your extended leg. Reach toward your toes as far as possible. Hold for 15 counts, then relax. Repeat 3 times for both legs. Stretches: Hamstrings, lower back and groin.

### 3. Calf/Achilles Stretch

With one leg in front of the other, reach forward and place your hands against a wall. Keep your back leg straight and your back foot flat on the floor. Bend your front leg, lean forward and move your hips toward the wall. Hold for 15 counts, then relax. Repeat 3 times for both legs. To cause further stretching of the achilles tendons, bend your back leg as well. Stretches: Calves, achilles tendons and ankles.

### 4. Quadriceps Stretch

With one hand against a wall for balance, reach back and grasp one foot with your other hand. Bring your heel as close to your buttocks as possible. Hold for 15 counts, then relax. Repeat 3 times for both legs. Stretches: Quadriceps and hip muscles.

### 5. Inner Thigh Stretch

Sit with the soles of your feet together and your knees outward. Pull your feet toward your groin area as far as possible. Hold for 15 counts, then relax. Repeat 3 times. Stretches: Quadriceps and hip muscles.

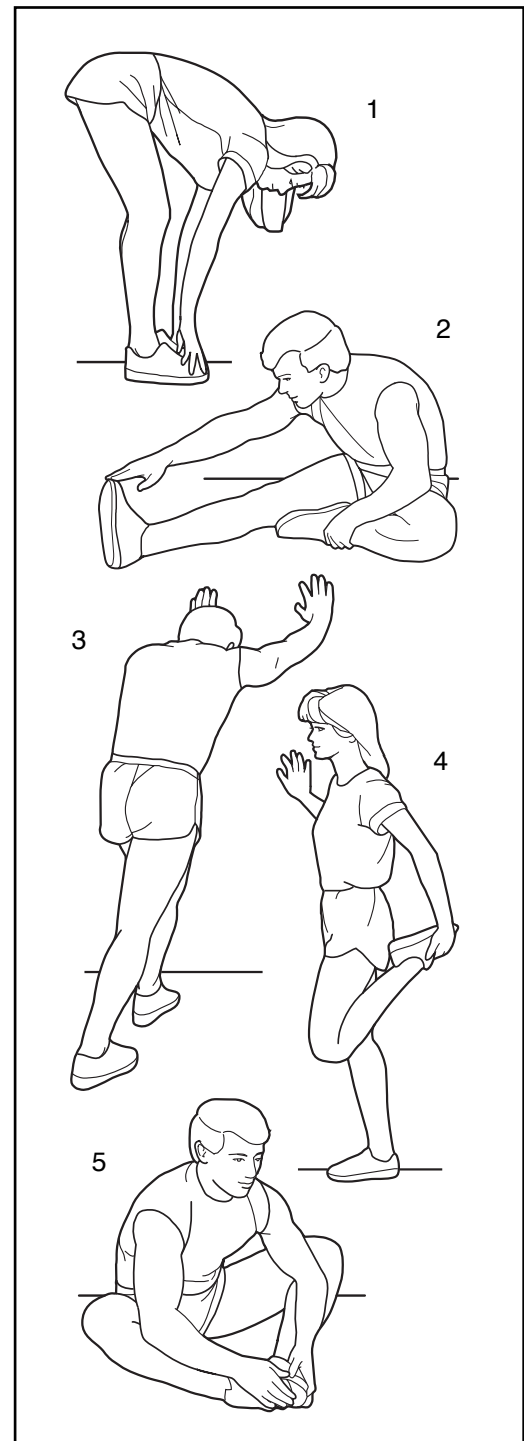

# PART LIST—Model No. WCTL84091

R1003A

Key No.	Qty.	Description	Key No.	Qty.	Description
1	2	Handrail	42	1	Rear Roller
2	1	Potentiometer	43	2	Rear Roller Adjustment Bolt
3	3	Cage Nut	44	1	Ground Wire
4	1	Console Housing	45	1	Right Endcap
5*	1	Console	46	1	Frame
6	12	Screw	47	1	Motor Pivot Bolt
7	4	3/8" x 1" Bolt	48	2	Roller Guard Screw
8	1	6" Cable Loom	49	1	Motor Tension Nut
9	1	Key/Clip	50	1	Motor Tension Star Washer
10	1	Upright Pivot Washer	51	2	Roller Guard
11	1	Choke	52	1	Electrical Warning Decal
12	1	Motor Hood	53	1	Motor Tension Washer
13	4	Hood Screw	54	2	Flange Nut
14	2	Upright Cover Screw	55	1	Motor
15	1	Reed Switch/Sensor Wire	56	1	Pulley/Flywheel/Fan
16	2	Adhesive Clip	57	1	4" Cable Tie
17	1	Motor Belt	58	5	8" Cable Tie
18	1	Speed Control Knob	59	2	Foot Rail w/Fastener
19	1	Pot Wire	60	2	Incline Leg Pad
20	1	Upright	61	2	Incline Leg
21	2	Wire Clip	62	2	Belt Guide
22	1	Motor Pivot Nut	63	7	Console Screw
23	5	Hood Anchor	64	3	Roller Adjustment Washer
24	1	Upright Wire Harness	65	1	Front Roller Adjustment Bolt
25	1	Safety Cover Plug	66	1	Front Roller/Pulley
26	1	Circuit Breaker	67	6	Platform Screw
27	1	3/8" x 1 1/2" Washer	68	1	Walking Belt w/Fastener
28	3	Clip Screw	69	1	Upright Pivot Nut
29	1	Upright Pivot Bolt	70	1	Magnet
30	1	Power Cord	71	2	5/16" x 3" Bolt
31	1	Grommet	72	2	Incline Leg Washer
32	6	Anchor Screw	73	1	Walking Platform w/Fastener
33	1	Safety Cover	74	1	Rear Leg Pad
34	9	Safety Cover Screw	75	1	Safety Cover Clip
35	1	Controller	#	12	Fastener
36	1	Battery Cover	#	1	14" White Wire, Male/Female
37	2	Incline Pin	#	1	User's Manual
38	1	Lower Upright Cover			
39*	1	Motor/Pulley/Flywheel/Fan			
40	1	Left Endcap			
41	1	Allen Wrench			

\* Includes all parts shown in the box.

# Indicates a non-illustrated part.

Specifications are subject to change without notice. See the back cover for information about ordering replacement parts.



# EXPLODED DRAWING—Model No. WCTL84091

R1003A

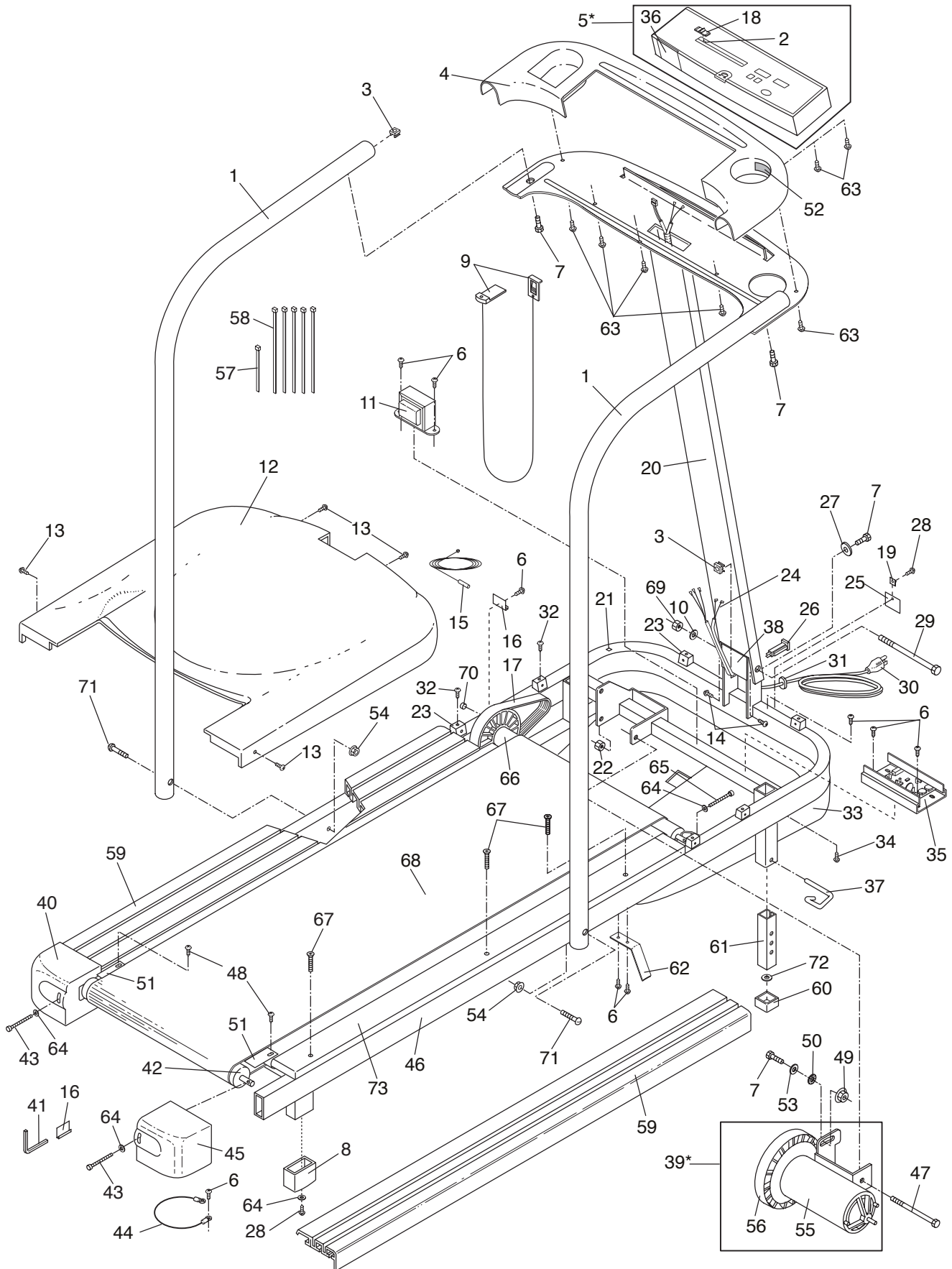

---

# CUSTOMER RECORD

Model No.: \_\_\_\_\_ Serial No.: \_\_\_\_\_

Retailer Name: \_\_\_\_\_ Purchase Date: \_\_\_\_\_

Retailer Address: \_\_\_\_\_

---

# ORDERING REPLACEMENT PARTS

To order replacement parts, call toll-free 1-888-936-4266, Monday through Friday 8h00 until 18h30 Eastern Time (excluding holidays). When ordering parts, please be prepared to give the following information:

- The MODEL NUMBER of the product (WCTL84091)
- The NAME of the product (WESLO® CADENCE 840 treadmill)
- The SERIAL NUMBER of the product (see the front cover of this manual)
- The KEY NUMBER AND DESCRIPTION OF THE PART(S) (see the EXPLODED DRAWING attached in the center of this manual and the PART LIST on pages 16 and 17)

**PLACE  
STAMP  
HERE**

ICON of Canada, Inc.  
900 de l'Industrie  
St-Jérôme, Québec  
Canada, J7Y 4B8

# LIMITED WARRANTY

ICON OF CANADA, INC., (ICON), warrants this product to be free from defects in workmanship and material, under normal use and service conditions, for a period of one (1) year from the date of purchase. This warranty extends only to the original purchaser. ICON's obligation under this warranty is limited to replacing or repairing, at ICON's option, the product through one of its authorized service centers. All repairs for which warranty claims are made must be pre-authorized by ICON. This warranty does not extend to any product or damage to a product caused by or attributable to freight damage, abuse, misuse, improper or abnormal usage or repairs not provided by an ICON authorized service center, to products used for commercial or rental purposes, or to products used as store display models. No other warranty beyond that specifically set forth above is authorized by ICON.

ICON is not responsible or liable for indirect, special or consequential damages arising out of or in connection with the use or performance of the product or damages with respect to any economic loss, loss of property, loss of revenues or profits, loss of enjoyment or use, costs of removal, installation or other consequential damages of whatsoever nature. Some provinces do not allow the exclusion or limitation of incidental or consequential damages. Accordingly, the above limitation may not apply to you. The warranty extended hereunder is in lieu of any and all other warranties and any implied warranties of merchantability or fitness for a particular purpose is limited in its scope and duration to the terms set forth herein. Some provinces do not allow limitations on how long an implied warranty lasts. Accordingly, the above limitation may not apply to you.

This warranty gives you specific legal rights. You may also have other rights which vary from province to province or so specified by the retailer of your equipment.

**ICON OF CANADA, INC., 900 de l'Industrie, St. Jerôme, QC J7Y 4B8**

✂



## WEIDER PRO-FORM WESLO

of Canada Inc.

### PRODUCT WARRANTY REGISTRATION

**IMPORTANT: MAIL WITHIN 14 DAYS OF PURCHASE**

NAME: \_\_\_\_\_ PHONE: \_\_\_\_\_

ADDRESS: \_\_\_\_\_

COUNTY: \_\_\_\_\_ POSTCODE: \_\_\_\_\_

MODEL NO. \_\_\_\_\_ SERIAL NO. \_\_\_\_\_ PURCHASE DATE: \_\_\_\_\_

RETAILER NAME: \_\_\_\_\_ RETAILER ADDRESS: \_\_\_\_\_

<p>1) Primary user(s) of product:  <input type="checkbox"/> Male      <input type="checkbox"/> Female      <input type="checkbox"/> Family</p> <p>2) Age of primary user:  <input type="checkbox"/> 0-24      <input type="checkbox"/> 35-44      <input type="checkbox"/> 55-64  <input type="checkbox"/> 25-34      <input type="checkbox"/> 45-54      <input type="checkbox"/> 65 and over</p> <p>3) Annual household income:  <input type="checkbox"/> 0-9,999      <input type="checkbox"/> 15,000-19,999  <input type="checkbox"/> 10,000-14,999      <input type="checkbox"/> 20,000+</p> <p>4) How many times a week do you exercise?  <input type="checkbox"/> Less than 3 times      <input type="checkbox"/> 3 times or more</p> <p>5) Have you ever purchased an ICON product before?  <input type="checkbox"/> Yes      <input type="checkbox"/> No</p> <p>6) Where did you first see or hear about ICON products?  <input type="checkbox"/> Magazine      <input type="checkbox"/> Friend/relative  <input type="checkbox"/> Newspaper Ad      <input type="checkbox"/> Store  <input type="checkbox"/> Other</p> <p>7) What was the primary reason for purchasing this ICON product?  <input type="checkbox"/> Store Employee      <input type="checkbox"/> Television Ads      <input type="checkbox"/> Colour  <input type="checkbox"/> Electronic Features      <input type="checkbox"/> Magazine Ads      <input type="checkbox"/> Price  <input type="checkbox"/> Product Design      <input type="checkbox"/> Product Innovation  <input type="checkbox"/> Other Features</p>	<p>8) Did you consider purchasing fitness equipment from another manufacturer?  <input type="checkbox"/> No      <input type="checkbox"/> Yes                      What other Manufacturer? _____</p> <p>9) Based on your impression of what you have purchased, would you buy another ICON product?  <input type="checkbox"/> Yes      <input type="checkbox"/> No      <input type="checkbox"/> No Opinion                      If not, what other brand name equipment would you purchase? _____</p> <p>10) What other type of exercise equipment do you own?  <input type="checkbox"/> Bicycle      <input type="checkbox"/> Exercise Cycle      <input type="checkbox"/> Treadmill  <input type="checkbox"/> Home Gym      <input type="checkbox"/> Weight Bench      <input type="checkbox"/> Stepper  <input type="checkbox"/> Cardio Glide      <input type="checkbox"/> Other</p> <p>11) Which type of magazines do you read regularly?  <input type="checkbox"/> Sports      <input type="checkbox"/> Fitness      <input type="checkbox"/> Motoring  <input type="checkbox"/> Business      <input type="checkbox"/> Computer      <input type="checkbox"/> General</p> <p>12) Do you wish to be sent further bulletins about ICON products?  <input type="checkbox"/> Yes      <input type="checkbox"/> No</p>
---	--

THANK YOU FOR YOUR TIME

© 2003 ICON of Canada, Inc. Printed in USA

## Free Manuals Download Website

<http://myh66.com>

<http://usermanuals.us>

<http://www.somanuals.com>

<http://www.4manuals.cc>

<http://www.manual-lib.com>

<http://www.404manual.com>

<http://www.luxmanual.com>

<http://aubethermostatmanual.com>

Golf course search by state

<http://golfingnear.com>

Email search by domain

<http://emailbydomain.com>

Auto manuals search

<http://auto.somanuals.com>

TV manuals search

<http://tv.somanuals.com>