

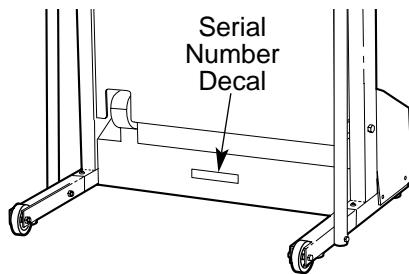

Model No. WLTL48410

Serial No. _____

Write the serial number in the space above for future reference.



USER'S MANUAL

QUESTIONS?

If you have questions, or if there are missing parts, we will guarantee complete satisfaction through direct assistance from our factory.

TO AVOID UNNECESSARY DELAYS, PLEASE CALL DIRECT TO OUR TOLL-FREE CUSTOMER HOT LINE. The trained technicians on our customer hot line will provide immediate assistance, free of charge to you.

CUSTOMER HOT LINE:

1-800-999-3756

Mon.-Fri., 6 a.m.-6 p.m. MST

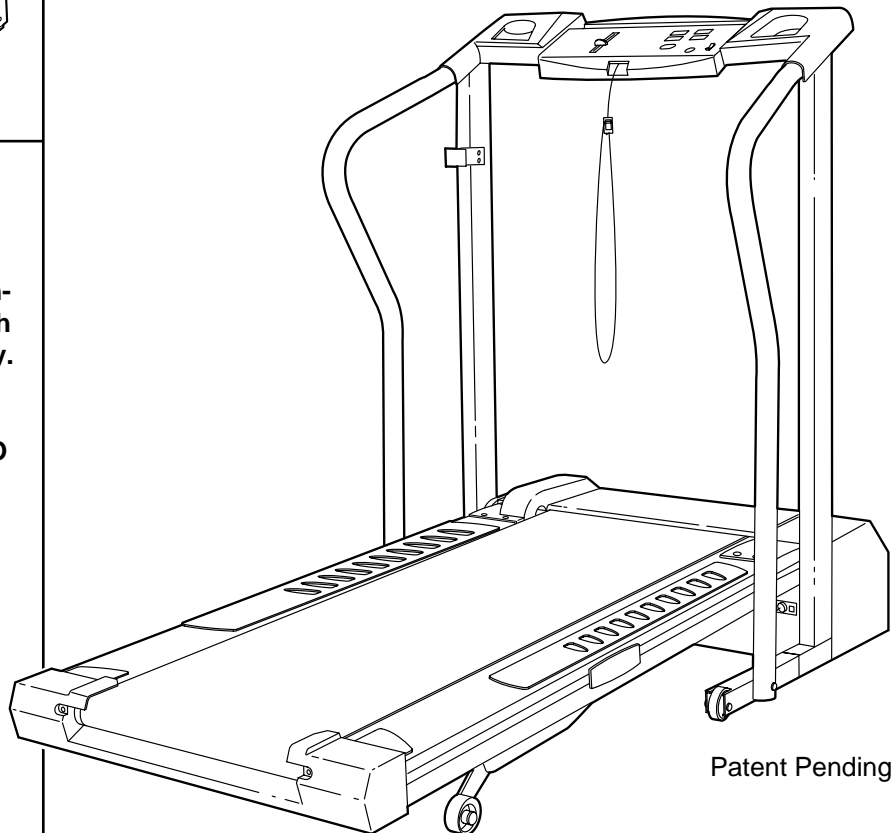

Patent Pending

CAUTION

Read all precautions and instructions in this manual before using this equipment. Save this manual for future reference.



Visit our website at

www.weslo.com

new products, prizes,
fitness tips, and much more!

TABLE OF CONTENTS

IMPORTANT PRECAUTIONS	2
BEFORE YOU BEGIN	4
ASSEMBLY	5
OPERATION AND ADJUSTMENT	7
HOW TO FOLD AND MOVE THE TREADMILL	10
TROUBLE-SHOOTING	12
CONDITIONING GUIDELINES	14
ORDERING REPLACEMENT PARTS	Back Cover
LIMITED WARRANTY	Back Cover

Note: An EXPLODED DRAWING and a PART LIST are attached in the center of this manual.

IMPORTANT PRECAUTIONS

⚠ WARNING: To reduce the risk of burns, fire, electric shock, or injury to persons, read the following important precautions and information before operating the treadmill.

1. It is the responsibility of the owner to ensure that all users of this treadmill are adequately informed of all warnings and precautions.
2. Use the treadmill only as described.
3. Place the treadmill on a level surface, with eight feet of clearance behind it. Do not place the treadmill on a surface that blocks any air openings. To protect the floor or carpet from damage, place a mat under the treadmill.
4. Keep the treadmill indoors, away from moisture and dust. Do not put the treadmill in a garage or covered patio, or near water.
5. Do not operate the treadmill where aerosol products are used or where oxygen is being administered.
6. Keep children under the age of 12 and pets away from the treadmill at all times.
7. The treadmill should be used only by persons weighing 250 pounds or less.
8. Never allow more than one person on the treadmill at a time.
9. Wear appropriate exercise clothing when using the treadmill. Do not wear loose clothing that could become caught in the treadmill.
10. Athletic support clothes are recommended for both men and women. Always wear athletic shoes. Never use the treadmill with bare feet, wearing only stockings, or in sandals.
10. When connecting the power cord (see page 7), plug the power cord into a surge suppressor (not included) and plug the surge suppressor into a grounded circuit capable of carrying 15 or more amps. No other appliance should be on the same circuit. Do not use an extension cord.
11. Use only a single-outlet surge suppressor that is UL 1449 listed as a transient voltage surge suppressor (TVSS). The surge suppressor must have a UL suppressed voltage rating of 400 volts or less and a minimum surge dissipation of 450 joules. The surge suppressor must be electrically rated for 120 volts AC and 15 amps. To purchase a surge suppressor, see your local WESLO dealer or call 1-800-999-3756 and order part number 146148.
12. Keep the power cord and the surge suppressor away from heated surfaces.
13. Never move the walking belt while the power is turned off. Do not operate the treadmill if the power cord or plug is damaged, or if the treadmill is not working properly. (See BEFORE YOU BEGIN on page 4 if the treadmill is not working properly.)

14. Never start the treadmill while you are standing on the walking belt. Always hold the handrails while using the treadmill.
15. The treadmill is capable of high speeds. Adjust the speed in small increments to avoid sudden jumps in speed.
16. Never leave the treadmill unattended while it is running. Always remove the key and unplug the power cord when the treadmill is not in use.
17. The pulse sensor is not a medical device. Various factors, including the user's movement, may affect the accuracy of heart rate readings. The pulse sensor is intended only as an exercise aid in determining heart rate trends in general.
18. Do not attempt to raise, lower, or move the treadmill until it is properly assembled. (See ASSEMBLY on pages 5 and 6, and HOW TO FOLD AND MOVE THE TREADMILL on page 10.) You must be able to safely lift 45 pounds (20 kg) to raise, lower, or move the treadmill.
19. When folding or moving the treadmill, make sure that the storage latch is fully closed.
20. Inspect and tighten all parts of the treadmill every three months.
21. Never drop or insert any object into any opening.
22. **DANGER:** Always unplug the power cord immediately after use, before cleaning the treadmill, and before performing the maintenance and adjustment procedures described in this manual. Never remove the motor hood unless instructed to do so by an authorized service representative. Servicing other than the procedures in this manual should be performed by an authorized service representative only.
23. This treadmill is intended for in-home use only. Do not use this treadmill in any commercial, rental, or institutional setting.

⚠ WARNING: Before beginning this or any exercise program, consult your physician. This is especially important for persons over the age of 35 or persons with pre-existing health problems. Read all instructions before using. ICON assumes no responsibility for personal injury or property damage sustained by or through the use of this product.

SAVE THESE INSTRUCTIONS

The decal shown below has been placed on your treadmill. If the decal is missing or illegible, please call our Customer Service Department, toll-free, to order a free replacement decal (see ORDERING REPLACEMENT PARTS on the back cover of this manual). Apply the decal in the location shown.

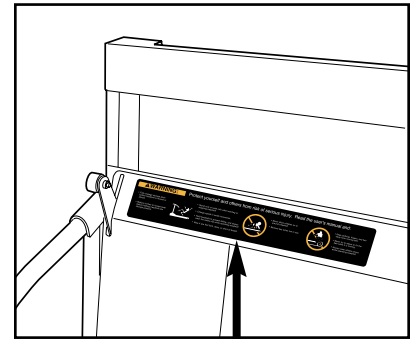

Note: Decal is shown at 38% of actual size.

⚠ WARNING: Protect yourself and others from risk of serious injury. Read the user's manual and:

<ul style="list-style-type: none"> • Fully engage storage latch before treadmill is moved or stored. • Reduce incline to lowest level before folding treadmill into storage position. 		<ul style="list-style-type: none"> • Stand only on side rails when starting or stopping treadmill. • Change speed in small increments. • Hold handrails to prevent falling, and always wear the safety clip while operating treadmill. • Stop if you feel faint, dizzy, or short of breath. 		<ul style="list-style-type: none"> • Never allow children on or around treadmill. • Remove key when not in use. 		<ul style="list-style-type: none"> • Keep clothing, fingers, and hair away from moving belt. • Never try to adjust or fix the belt while it is moving. • Always wear athletic shoes while operating treadmill.
---	---	---	---	---	---	---

BEFORE YOU BEGIN

Thank you for selecting the WESLO® CADENCE 40.8 CT treadmill. The CADENCE 40.8 CT combines advanced technology with innovative design to let you enjoy an excellent form of cardiovascular exercise in the convenience and privacy of your home. And when you're not exercising, the CADENCE 40.8 CT can be folded up, requiring less than half the floor space of other treadmills.



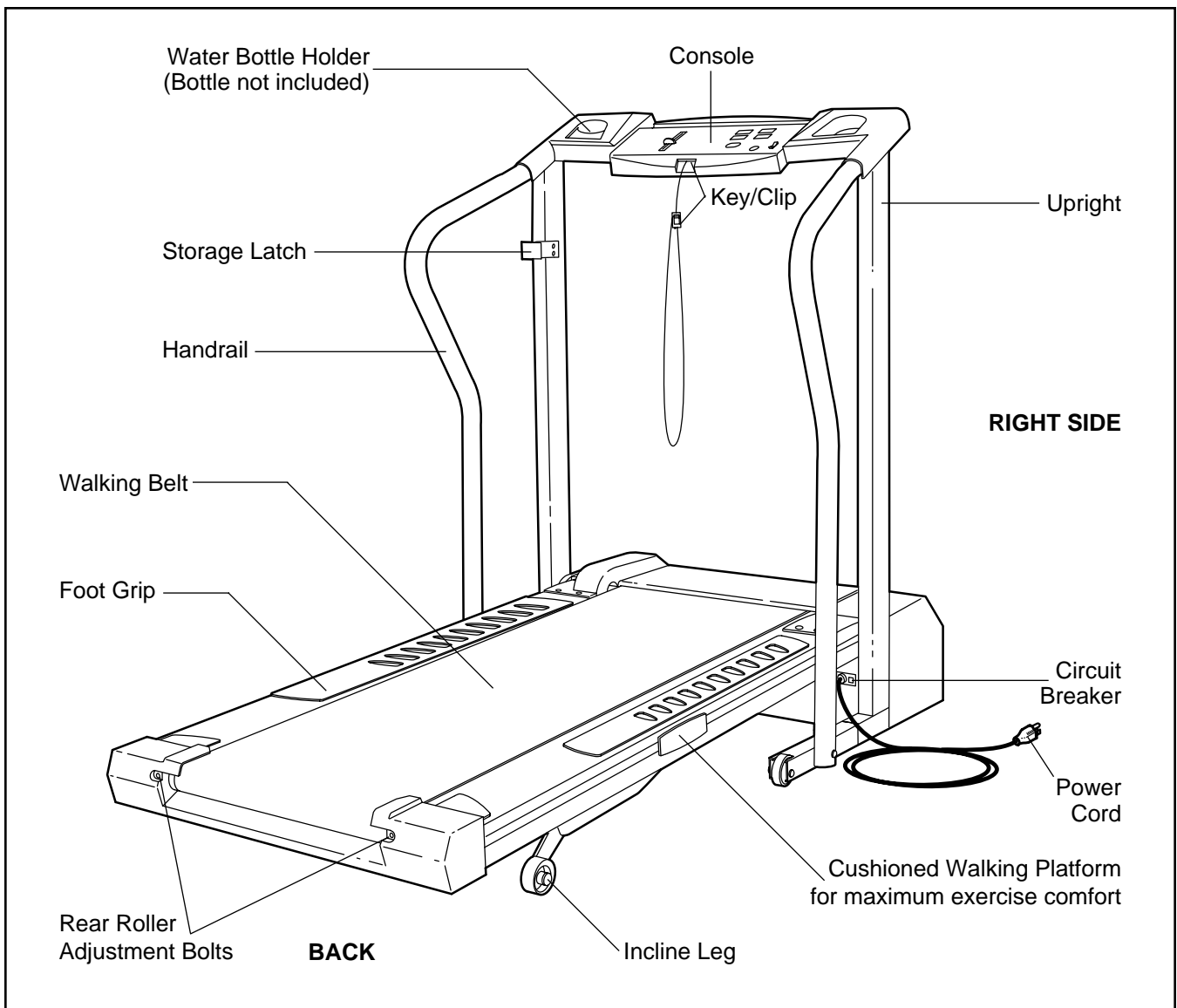

For your benefit, read this manual carefully before using the treadmill. If you have additional questions,

please call our Customer Service Department toll-free at 1-800-999-3756, Monday through Friday, 6 a.m. until 6 p.m. Mountain Time (excluding holidays). To help us assist you, please note the product model number and serial number before calling. The model number of the treadmill is WLT48410. The serial number can be found on a decal attached to the treadmill (see the front cover of this manual for the location).

Before reading further, please familiarize yourself with the parts that are labeled in the drawing below.

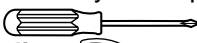

ASSEMBLY

Assembly requires two persons. Set the treadmill in a cleared area and remove the packing materials. Do not dispose of the packing materials until assembly is completed. **Assembly requires the included allen wrench and your own phillips screwdriver** , **adjustable wrench** , **wire cutters**  and **needle-nose pliers** .

Note: The underside of the treadmill walking belt is coated with high-performance lubricant. During shipping, a small amount of lubricant may be transferred to the top of the walking belt or the shipping carton. This is a normal condition and does not affect treadmill performance. If there is lubricant on top of the walking belt, simply wipe off the lubricant with a soft cloth and a mild, non-abrasive cleaner.

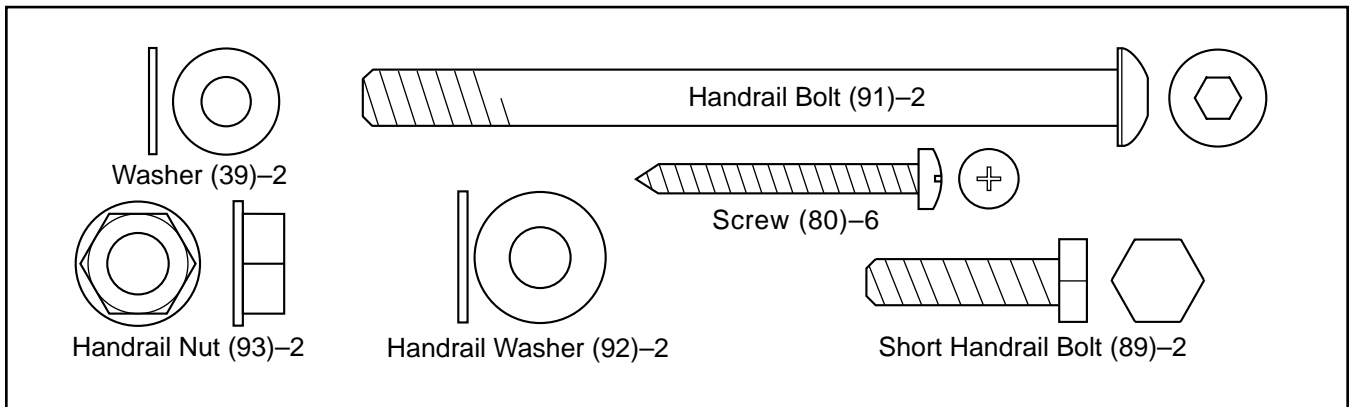

1. With the help of a second person, carefully raise the Uprights (11) until the treadmill is in the position shown.

Cut the tie from the right Upright (11).

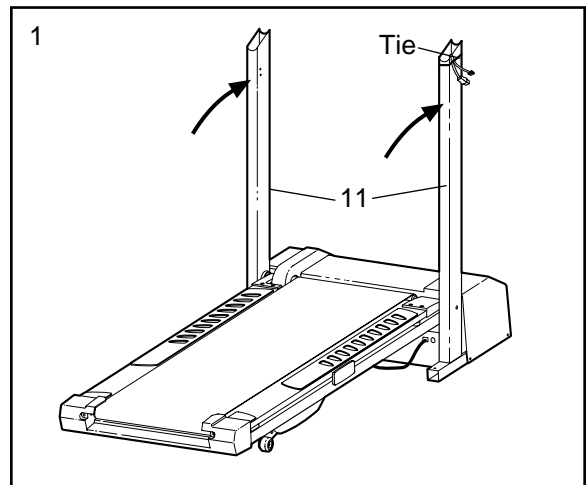

2. Back out the Extension Leg Screw (53). Insert one of the Extension Legs (34) into the treadmill as shown. (Note: It may be helpful to tip the Uprights [11] in the direction shown by the arrow as you insert the Extension Leg.) Make sure that the Base Pad (40) is on the indicated side of the Extension Leg. Attach the Extension Leg with an Extension Leg Screw. **Be sure to push on the head of the Extension Leg Screw while tightening it.**

Attach the other Extension Leg (34) in the same way.

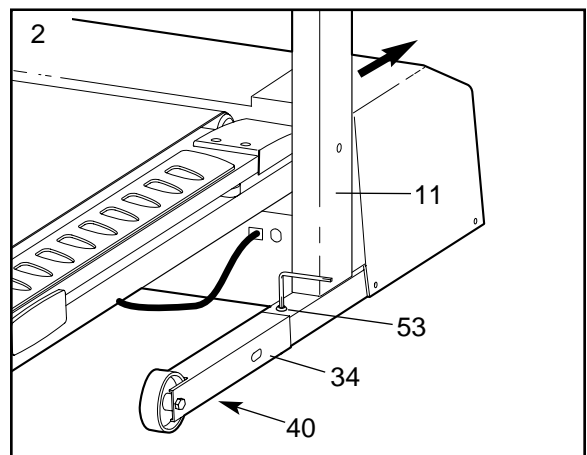

- Refer to the inset drawing. If there is a plastic tie holding the Cage Nut (70) in the Right Handrail (88), remove the plastic tie. Feed the Wire Harness (21) in the right Upright (11) through the bracket on the Right Handrail (88) as shown. Using needlenose pliers, grip one of the connectors on the Wire Harness and pull the Wire Harness up through the hole in the Right Handrail.

Insert the bracket on the Right Handrail (88) into the upper end of the right Upright (11), with the lower end of the Right Handrail on the side of the Extension Leg (34) as shown. Hand tighten a Short Handrail Bolt (89) with a Washer (39) into the upper end of the Upright.

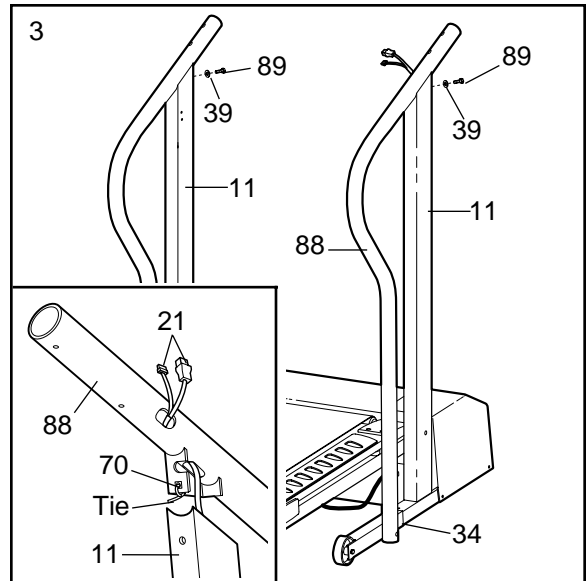

- Attach the lower end of the Right Handrail (88) to the Extension Leg (34) with a Handrail Bolt (91), a Handrail Washer (92), and a Handrail Nut (93) as shown. **Do not tighten the Handrail Bolt yet.** Note: It may be necessary to push on the lower end of the Handrail to align the hole in the Handrail with the hole in the Extension Leg.

Attach the Left Handrail to the left Extension Leg (not shown) as described in steps 3 and 4.

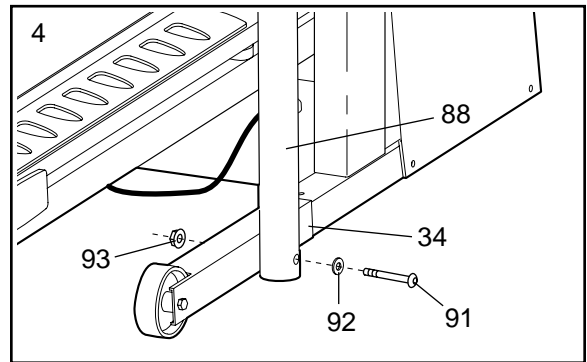

- Place the Console Base (46) on the Uprights (11) (the left Upright is not shown). Make a loop in the indicated cable tie and insert the two Wires (21) through the loop. Connect the two Wires to the connectors in the Console Base. **Important: Make sure that the Wires are fully inserted.** Pull the cable tie tight and cut off the end. **WARNING: Do not disconnect or connect the Wires while the treadmill power cord is plugged in.**

Thread four Screws (80) into the Uprights (11) and the Console Base (46). After all four Screws have been started, **tighten the Screws until they are snug; do not overtighten the Screws.**

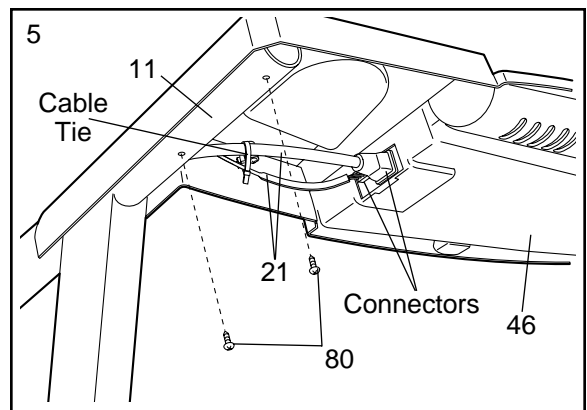

- Attach the Storage Latch (14) to the left Upright (11) with two Screws (80). **Do not overtighten the Screws.**

Tighten all of the bolts used in steps 3 and 4.

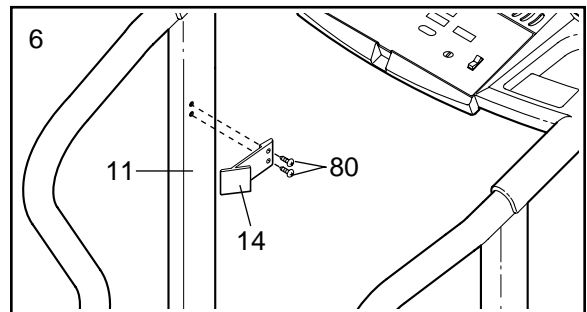

- Make sure that all parts are tightened before you use the treadmill.** Keep the included allen wrench in a secure place. The allen wrench is used to adjust the walking belt (see page 13). To protect the floor or carpet, place a mat under the treadmill.

OPERATION AND ADJUSTMENT

THE PERFORMANT LUBE™ WALKING BELT

Your treadmill features a walking belt coated with PERFORMANT LUBE™, a high-performance lubricant.

IMPORTANT: Never apply silicone spray or other substances to the walking belt or the walking platform. Such substances will deteriorate the walking belt and cause excessive wear.

HOW TO PLUG IN THE POWER CORD

⚠ DANGER: Improper connection of the equipment-grounding conductor can result in an increased risk of electric shock. Check with a qualified electrician or serviceman if you are in doubt as to whether the product is properly grounded. Do not modify the plug provided with the product—if it will not fit the outlet, have a proper outlet installed by a qualified electrician.

Your treadmill, like any other type of sophisticated electronic equipment, can be seriously damaged by sudden voltage changes in your home's power. Voltage surges, spikes, and noise interference can result from weather conditions or from other appliances being turned on or off. **To decrease the possibility of your treadmill being damaged, always use a surge suppressor with your treadmill (see drawing 1 at the right).**

To purchase a surge suppressor, see your local WESLO dealer or call toll-free 1-800-999-3756 and order part number 146148. Use only a single-outlet surge suppressor that is UL 1449 listed as a transient voltage surge suppressor (TVSS). The surge suppressor must have a UL suppressed voltage rating of 400 volts or less and a minimum surge dissipation of 450 joules. The surge suppressor must be electrically rated for 120 volts AC and 15 amps.

This product must be grounded. If it should malfunction or break down, grounding provides a path of least resistance for electric current to reduce the risk of electric shock. This product is equipped with a cord having an equipment-grounding conductor and a grounding plug. **Plug the power cord into a surge suppressor, and plug the surge suppressor into an appropriate outlet that is properly installed and grounded in accordance with all local codes and ordinances. Important: The treadmill is not compatible with GFCI-equipped outlets.**

This product is for use on a nominal 120-volt circuit, and has a grounding plug that looks like the plug illustrated in drawing 1 below. A temporary adapter that looks like the adapter illustrated in drawing 2 may be used to connect the surge suppressor to a 2-pole receptacle as shown in drawing 2 if a properly grounded outlet is not available.

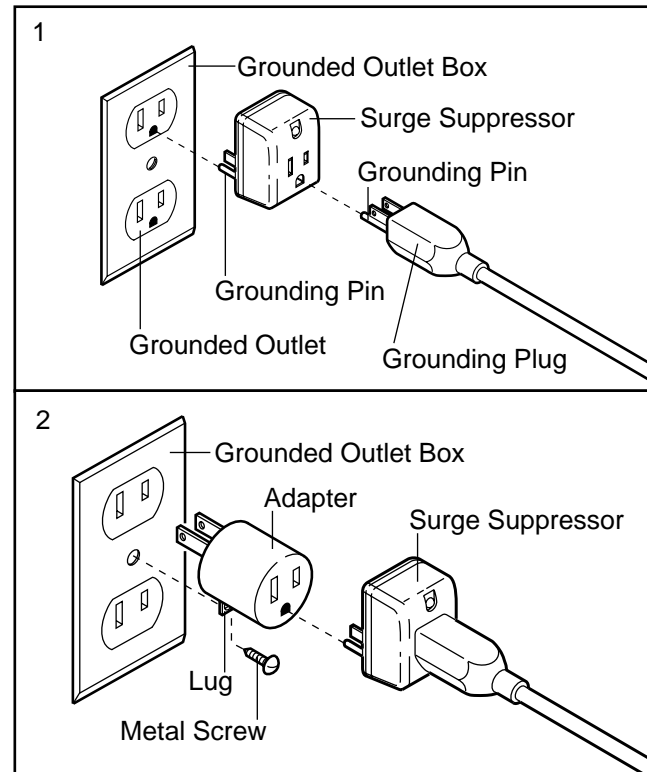

The temporary adapter should be used only until a properly grounded outlet (drawing 1) can be installed by a qualified electrician.

The green-colored rigid ear, lug, or the like extending from the adapter must be connected to a permanent ground such as a properly grounded outlet box cover. Whenever the adapter is used it must be held in place by a metal screw. **Some 2-pole receptacle outlet box covers are not grounded. Contact a qualified electrician to determine if the outlet box cover is grounded before using an adapter.**

DIAGRAM OF THE CONSOLE

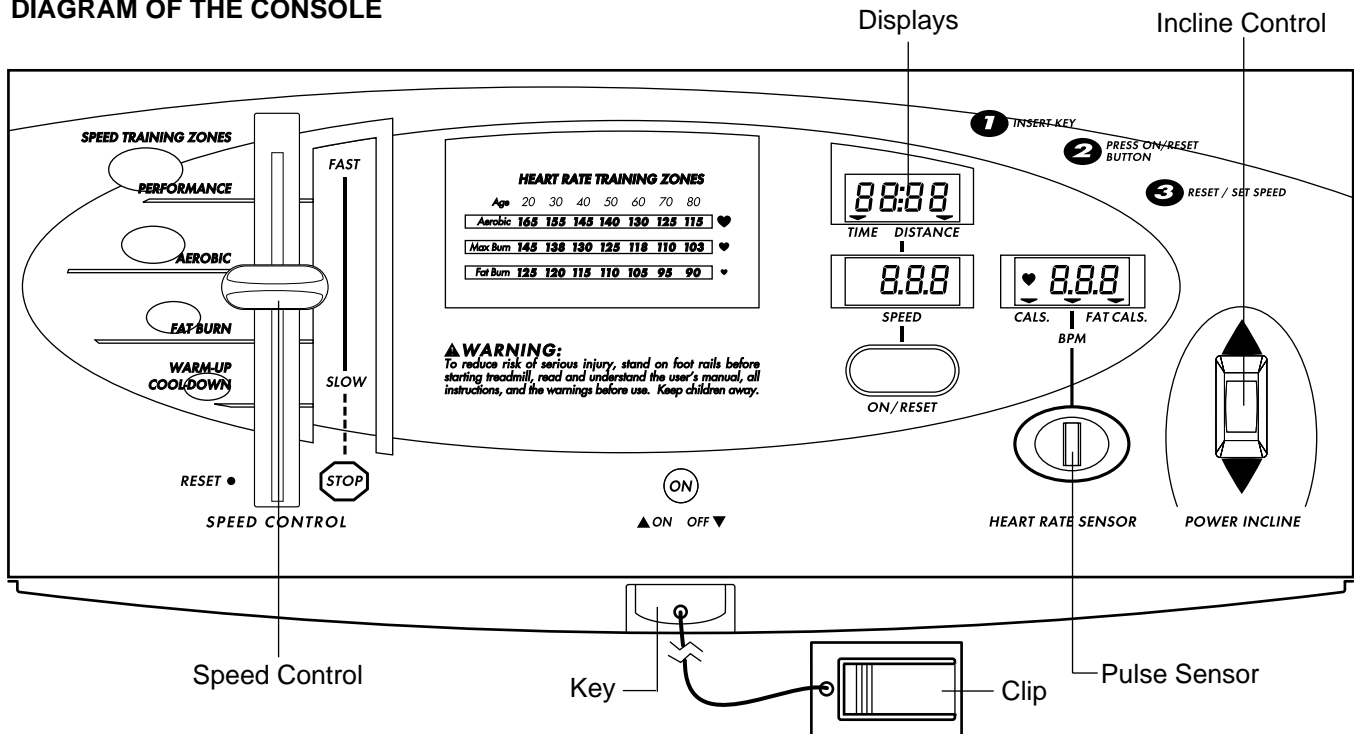

⚠ CAUTION: Before operating the console, read the following precautions.

- Do not stand on the walking belt when turning on the power.
- Always wear the clip (see the drawing above) while using the treadmill. When the key is removed from the console, the walking belt will stop.

- Adjust the speed in small increments.
- The training zones marked beside the speed control are general guidelines only. See page 14 for more information.
- To reduce the possibility of electric shock, keep the console dry. Avoid spilling liquids on the console. Use only a sealable water bottle.

BATTERY INSTALLATION

The console requires **three "AA" batteries** (not included). Alkaline batteries are recommended. To install batteries, open the battery cover as shown below. Press the batteries into the battery compartment, with the negative (-) ends of the batteries touching the springs. Close the battery cover, push up on the tab,

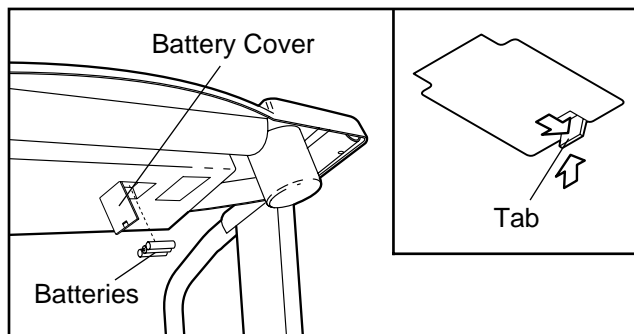

and then push the tab forward as shown. Be sure that the tab locks into place.

STEP-BY-STEP CONSOLE OPERATION

If there is a thin sheet of plastic on the console, remove it. Before operating the console, make sure that the power cord is properly plugged in. (Refer to page 7.)

Next, step onto the foot grips of the treadmill. Find the clip attached to the key (see the drawing above), and slide the clip onto the waistband of your clothing. **Test the clip by carefully taking a few steps backward until the key is pulled from the console. If the key is not pulled from the console, adjust the position of the clip as needed.**

Follow the steps on page 9 to operate the console.

1 Insert the key fully into the power switch.

Note: Inserting the key will not turn on the displays. The displays will turn on when the ON/RESET button is pressed or when the walking belt is started. (If you just installed batteries, the displays will be on.)

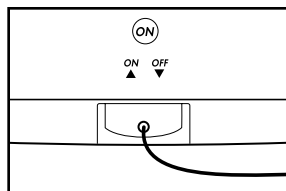

2 Reset the console and start the walking belt.

Slide the speed control to the RESET position. **Note: Each time the walking belt is stopped, the speed control must be moved to the RESET position before the walking belt can be restarted.** Next, slowly slide the speed control up until the walking belt begins to move at slow speed.

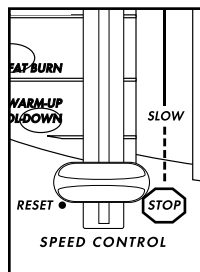

Carefully step onto the walking belt and begin exercising. Change the speed of the walking belt as desired by sliding the speed control.

To stop the walking belt, step onto the foot grips and slide the speed control to the RESET position.

3 Adjust the incline of the treadmill as desired.

To change the incline of the treadmill, press the top or bottom of the incline control until the desired incline level is reached.

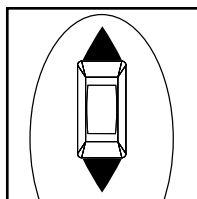

4 Follow your progress with the three displays.

TIME/DISTANCE display—This display shows the elapsed time and distance that you have walked or run. Every seven seconds, the display will change from one number to the other, as indicated by the mode arrows.

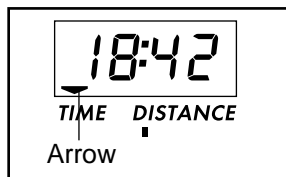

SPEED display—This display shows the speed of the walking belt, in miles per hour.

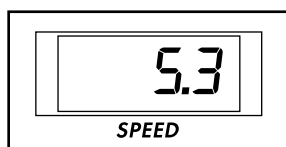

CALORIES/FAT CALORIES/PULSE display—This display shows the approximate numbers of calories and fat calories you have burned. (See FAT BURNING on page 14.) Every seven seconds, the display will change from one number to the other, as indicated by the mode arrows. This display will also show your heart rate when the pulse sensor is used (see step 5).

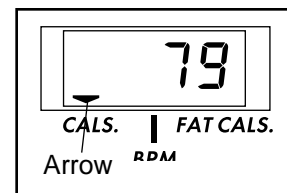

To reset the displays at any time, press the ON/RESET button.

5 Measure your heart rate, if desired.

To measure your heart rate, stand on the foot grips and place your thumb on the pulse sensor as shown. The pulse sensor is pressure activated—fully press it down. **Do not press too hard, or the circulation in your thumb will be restricted, and your pulse will not be detected.** Next, raise your thumb slightly until the pulse indicator in the CALORIES/FAT CALORIES/PULSE display flashes **steadily**. Hold your thumb at this level. After a few seconds, three dashes will appear and then your heart rate will be shown. Hold your thumb on the sensor for 15 seconds for the most accurate reading.

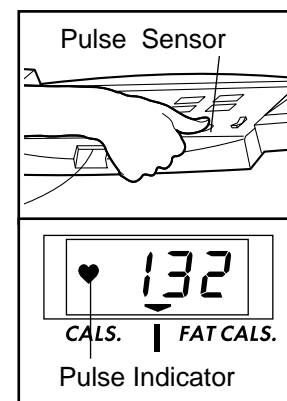

If the displayed heart rate appears to be too high or too low, or if your heart rate is not displayed, lift your thumb and allow the display to reset. Press down again on the sensor as described above. Make sure that your thumb is positioned as shown and that you are applying the proper amount of pressure. Try the sensor several times until you are familiar with it. Remember to stand still while measuring your pulse.

6 Remove the key from the power switch.

When you are finished exercising, step onto the foot grips, slide the speed control to the RESET position, and remove the key. The displays will turn off about four minutes after the key is removed. **Note: Any time that the walking belt is stationary and the console is not used for four minutes, the displays will turn off automatically.**

HOW TO FOLD AND MOVE THE TREADMILL

HOW TO FOLD THE TREADMILL FOR STORAGE

Before folding the treadmill, unplug the power cord.

CAUTION: You must be able to safely lift 45 pounds (20 kg) in order to raise, lower, or move the treadmill.

1. Hold the treadmill with your hands in the locations shown at the right. **To decrease the possibility of injury, bend your legs and keep your back straight. As you raise the treadmill, make sure to lift with your legs rather than your back.** Raise the treadmill about halfway to the vertical position.

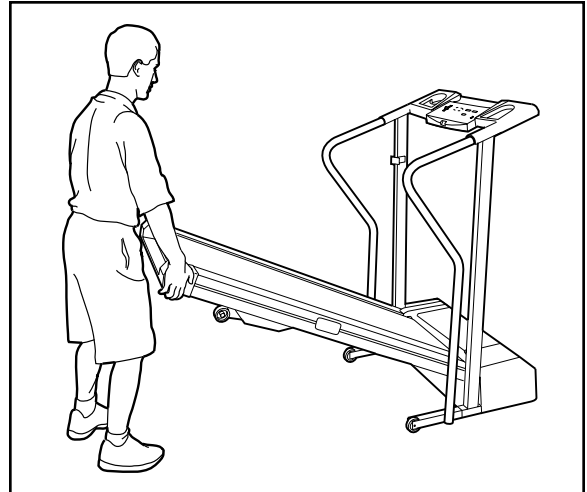

2. Move your right hand to the position shown and hold the treadmill firmly. Raise the treadmill until the storage latch closes over the catch. **Make sure that the storage latch is fully engaged over the catch.**

To protect the floor or carpet from damage, place a mat under the treadmill. Keep the treadmill out of direct sunlight. Do not leave the treadmill in the storage position in temperatures above 85° Fahrenheit.

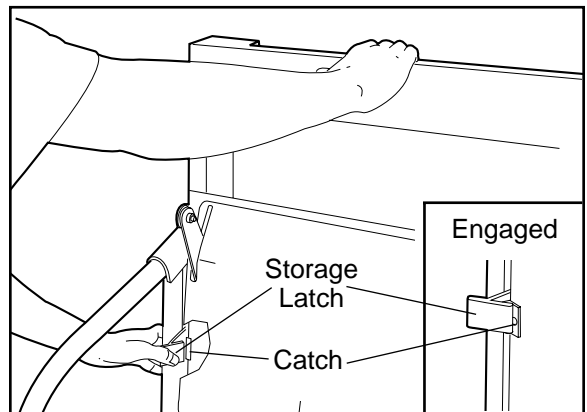

HOW TO MOVE THE TREADMILL

Before moving the treadmill, convert the treadmill to the storage position as described above. **Make sure that the storage latch is closed fully over the catch.**

1. Hold the upper ends of the handrails. Place one foot on the base as shown.
2. Tilt the treadmill back until it rolls freely on the front wheels. Carefully move the treadmill to the desired location. **To reduce the risk of injury, use extreme caution while moving the treadmill. Do not move the treadmill over an uneven surface.**
3. Place one foot on the base, and carefully lower the treadmill until it is resting in the storage position.

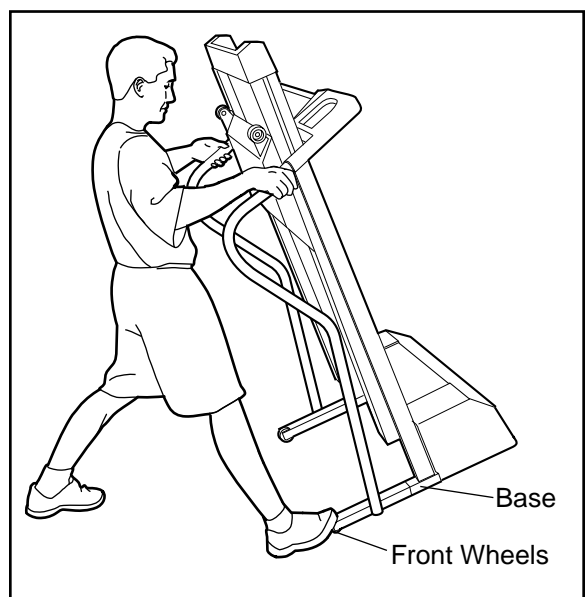

HOW TO LOWER THE TREADMILL FOR USE

1. Hold the upper end of the treadmill with your right hand as shown. Using your left thumb, press the storage latch and hold it. Pivot the treadmill until the frame and foot rail are past the storage latch.

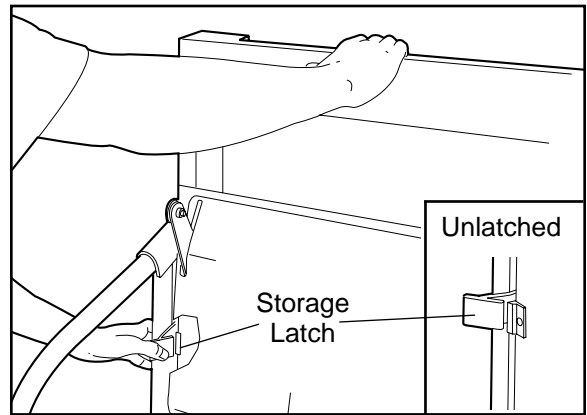

2. Hold the treadmill firmly with both hands, and lower the treadmill to the floor. **Do not drop the treadmill frame to the floor. To decrease the possibility of injury, bend your legs and keep your back straight.**

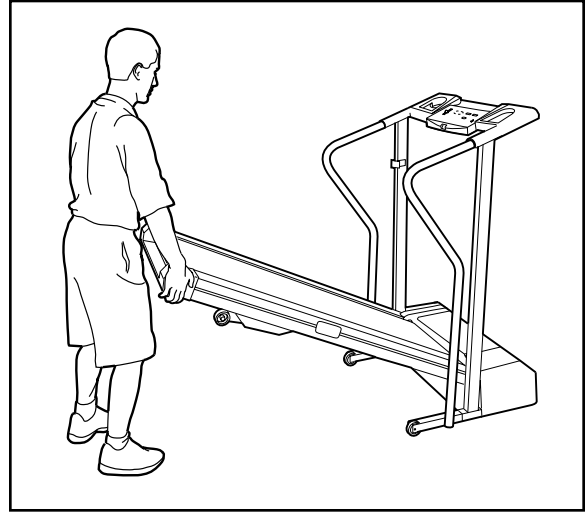

MAINTENANCE AND TROUBLE-SHOOTING

Most treadmill problems can be solved by following the steps below. Find the symptom that applies, and follow the steps listed. If further assistance is needed, please call our Customer Service Department toll-free at 1-800-999-3756, Monday through Friday, 6 a.m. until 6 p.m. Mountain Time (excluding holidays).

PROBLEM: The power does not turn on

SOLUTION: a. Make sure that the power cord is plugged into a surge suppressor, and that the surge suppressor is plugged into a properly grounded outlet (see page 7). Use only a single-outlet surge suppressor that is UL 1449 listed as a transient voltage surge suppressor (TVSS). The surge suppressor must have a UL suppressed voltage rating of 400 volts or less and a minimum surge dissipation of 450 joules. The surge suppressor must be electrically rated for 120 volts AC and 15 amps. Important: The treadmill is not compatible with GFCI-equipped outlets.

b. After the power cord has been plugged in, make sure that the key is fully inserted into the console.

c. Check the circuit breaker located on the treadmill frame near the power cord. If the switch protrudes as shown, the circuit breaker has tripped. To reset the circuit breaker, wait for five minutes and then press the switch back in.

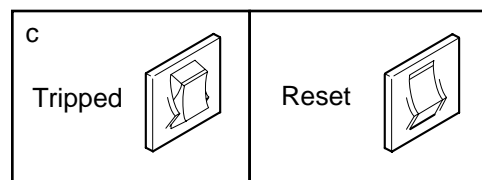

PROBLEM: The power turns off during use

SOLUTION: a. Check the circuit breaker located on the treadmill frame near the power cord (see the drawing above). If the circuit breaker has tripped, wait for five minutes and then press the switch back in.

b. Make sure that the power cord is plugged in.

c. Remove the key from the console. Reinsert the key fully into the console.

d. If the treadmill still will not run, please call our Customer Service Department, toll-free.

PROBLEM: The displays of the console do not function properly

SOLUTION: a. Check the batteries in the console. If the batteries need to be replaced, see "BATTERY INSTALLATION" on page 8. Most problems are the result of drained batteries.

b. Remove the screws from the hood, and carefully remove the hood. Locate the Reed Switch (44) and the Magnet (45) on the left side of the Pulley (50). Turn the Pulley until the Magnet is aligned with the Reed Switch. **Make sure that there is a gap of about 1/8" between the Magnet and the Reed Switch.** If necessary, loosen the Screw (33) and move the Reed Switch slightly. Retighten the Screw. Re-attach the hood, and run the treadmill for a few minutes to check for a correct speed reading.

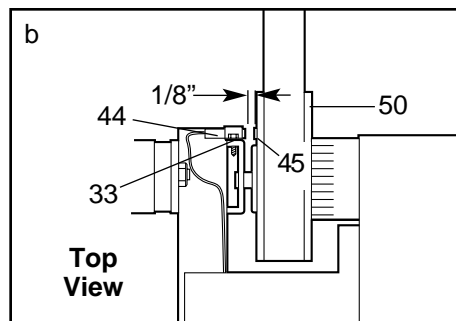

PROBLEM: The walking belt slows when walked on

SOLUTION: a. Use only a single-outlet surge suppressor that is UL 1449 listed as a transient voltage surge suppressor (TVSS). The surge suppressor must have a UL suppressed voltage rating of 400 volts or less and a minimum surge dissipation of 450 joules. The surge suppressor must be electrically rated for 120 volts AC and 15 amps.

b. If the walking belt is overtightened, treadmill performance may decrease and the walking belt may become damaged. Remove the key and **UNPLUG THE POWER CORD**. Using the allen wrench, turn both rear roller adjustment bolts counterclockwise, 1/4 of a turn. When the walking belt is properly tightened, you should be able to lift each side of the walking belt 2 to 3 inches off the walking platform. Be careful to keep the walking belt centered. Plug in the power cord, insert the key and run the treadmill for a few minutes. Repeat until the walking belt is properly tightened.

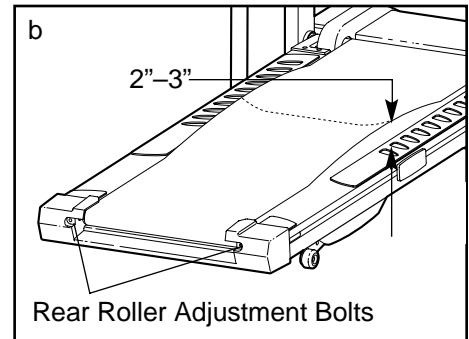

c. If the walking belt still slows when walked on, please call our Customer Service Department, toll-free.

PROBLEM: The walking belt is off-center or slips when walked on

SOLUTION: a. **If the walking belt has shifted to the left**, first remove the key and **UNPLUG THE POWER CORD**. Using the allen wrench, turn the left rear roller bolt clockwise 1/2 of a turn. Be careful not to overtighten the walking belt. **If the walking belt has shifted to the right**, turn the left rear roller bolt counterclockwise 1/2 of a turn. Plug in the power cord, insert the key and run the treadmill for a few minutes. Repeat until the walking belt is centered.

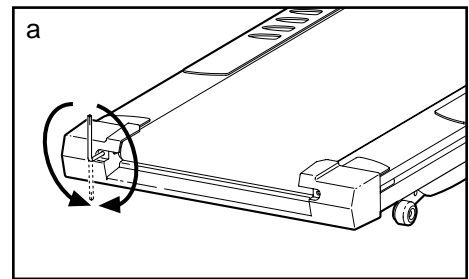

b. If the walking belt slips when walked on, first remove the key and **UNPLUG THE POWER CORD**. Using the allen wrench, turn both rear roller bolts clockwise, 1/4 of a turn. When the walking belt is correctly tightened, you should be able to lift each side of the walking belt 2 to 3 inches off the walking platform. Be careful to keep the walking belt centered. Plug in the power cord, insert the key and carefully walk on the treadmill for a few minutes. Repeat until the walking belt is properly tightened.

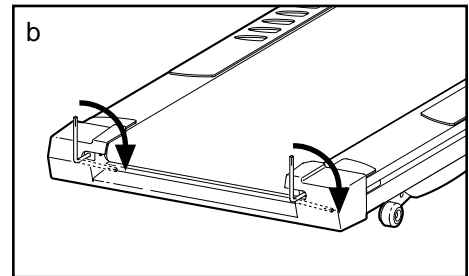

CONDITIONING GUIDELINES

⚠ WARNING: Before beginning this or any exercise program, consult your physician. This is especially important for individuals over the age of 35 or individuals with pre-existing health problems.

The pulse sensor is not a medical device. Various factors, including the user's movement, may affect the accuracy of heart rate readings. The pulse sensor is intended only as an exercise aid in determining heart rate trends in general.

The following guidelines will help you to plan your exercise program. For more detailed exercise information, obtain a reputable book or consult your physician.

EXERCISE INTENSITY

Whether your goal is to burn fat or to strengthen your cardiovascular system, the key to achieving the desired results is to exercise with the proper intensity. The proper intensity level can be found by using your heart rate as a guide. The chart below shows recommended heart rates for fat burning and aerobic exercise.

HEART RATE TRAINING ZONES								
Age	20	30	40	50	60	70	80	
Aerobic	165	155	145	140	130	125	115	♥
Max Burn	145	138	130	125	118	110	103	♥
Fat Burn	125	120	115	110	105	95	90	♥

To find the proper heart rate for you, first find your age near the top of the chart (ages are rounded off to the nearest ten years). Next, find the three numbers below your age. The three numbers are your "training zone." The lower two numbers are recommended heart rates for fat burning; the highest number is the recommended heart rate for aerobic exercise.

Fat Burning

To burn fat effectively, you must exercise at a relatively low intensity level for a sustained period of time. During the first few minutes of exercise, your body uses easily accessible carbohydrate calories for energy. Only after

the first few minutes does your body begin to use stored fat calories for energy. If your goal is to burn fat, adjust the speed and incline of the treadmill until your heart rate is near one of the lower two numbers in your training zone. It may also be helpful to set the speed control on the console to FAT BURN to help you maintain the proper intensity level. (See page 9.)

Aerobic Exercise

If your goal is to strengthen your cardiovascular system, your exercise must be "aerobic." Aerobic exercise is activity that requires large amounts of oxygen for prolonged periods of time. This increases the demand on the heart to pump blood to the muscles, and on the lungs to oxygenate the blood. For aerobic exercise, adjust the speed and incline of the treadmill until your heart rate is near the higher number in your training zone. It may also be helpful to set the speed control on the console to AEROBIC to help you maintain the proper intensity level. (See page 9.)

High Performance Athletic Conditioning

If your goal is high performance athletic conditioning, set the speed control on the console to PERFORMANCE to help you maintain the proper intensity level. (See page 9.) Note: During the first few weeks of your exercise program, keep your heart rate near the low end of your training zone.

WORKOUT GUIDELINES

Each workout should include the following three parts:

A Warm-up—Start each workout with 5 to 10 minutes of stretching and light exercise. A proper warm-up increases your body temperature, heart rate, and circulation in preparation for exercise.

Training Zone Exercise—After warming up, increase the intensity of your exercise until your heart rate is in your training zone for 20 to 60 minutes. (During the first few weeks of your exercise program, do not keep your heart rate in your training zone for longer than 20 minutes.)

A Cool-down—Finish each workout with 5 to 10 minutes of stretching to cool down. This will increase the flexibility of your muscles and will help to prevent post-exercise problems.

EXERCISE FREQUENCY

To maintain or improve your condition, complete three workouts each week, with at least one day of rest be-

tween workouts. After a few months of regular exercise, you may complete up to five workouts each week if desired. The key to success is to make exercise a regular and enjoyable part of your everyday life.

SUGGESTED STRETCHES

The correct form for several basic stretches is described below. Move slowly as you stretch—never bounce.

1. Toe Touch Stretch

Stand with your knees bent slightly and slowly bend forward from your hips. Allow your back and shoulders to relax as you reach down toward your toes as far as possible. Hold for 15 counts, then relax. Repeat 3 times. Stretches: Hamstrings, back of knees and back.

2. Hamstring Stretch

Sit with one leg extended. Bring the sole of the opposite foot toward you and rest it against the inner thigh of your extended leg. Reach toward your toes as far as possible. Hold for 15 counts, then relax. Repeat 3 times for each leg. Stretches: Hamstrings, lower back and groin.

3. Calf/Achilles Stretch

With one leg in front of the other, reach forward and place your hands against a wall. Keep your back leg straight and your back foot flat on the floor. Bend your front leg, lean forward and move your hips toward the wall. Hold for 15 counts, then relax. Repeat 3 times for each leg. To cause further stretching of the achilles tendons, bend your back leg as well. Stretches: Calves, achilles tendons and ankles.

4. Quadriceps Stretch

With one hand against a wall for balance, reach back and grasp one foot with your other hand. Bring your heel as close to your buttocks as possible. Hold for 15 counts, then relax. Repeat 3 times for each leg. Stretches: Quadriceps and hip muscles.

5. Inner Thigh Stretch

Sit with the soles of your feet together and your knees outward. Pull your feet toward your groin area as far as possible. Hold for 15 counts, then relax. Repeat 3 times. Stretches: Quadriceps and hip muscles.

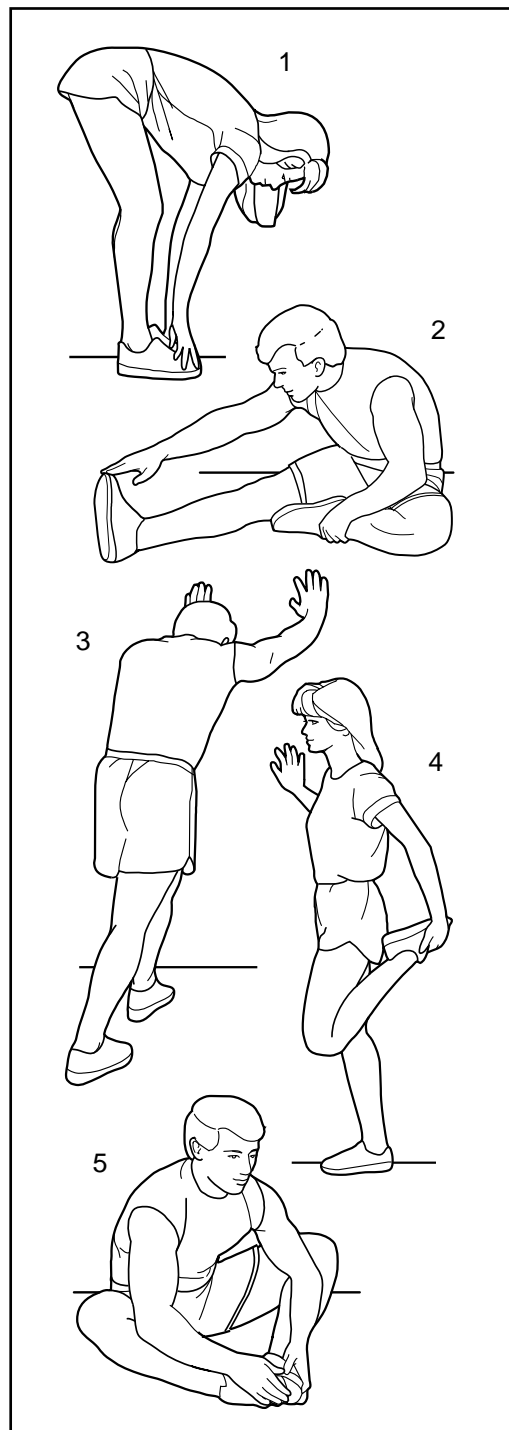

REMOVE THIS EXPLODED DRAWING AND PART LIST FROM THE MANUAL

Save this EXPLODED DRAWING and PART LIST for future reference.

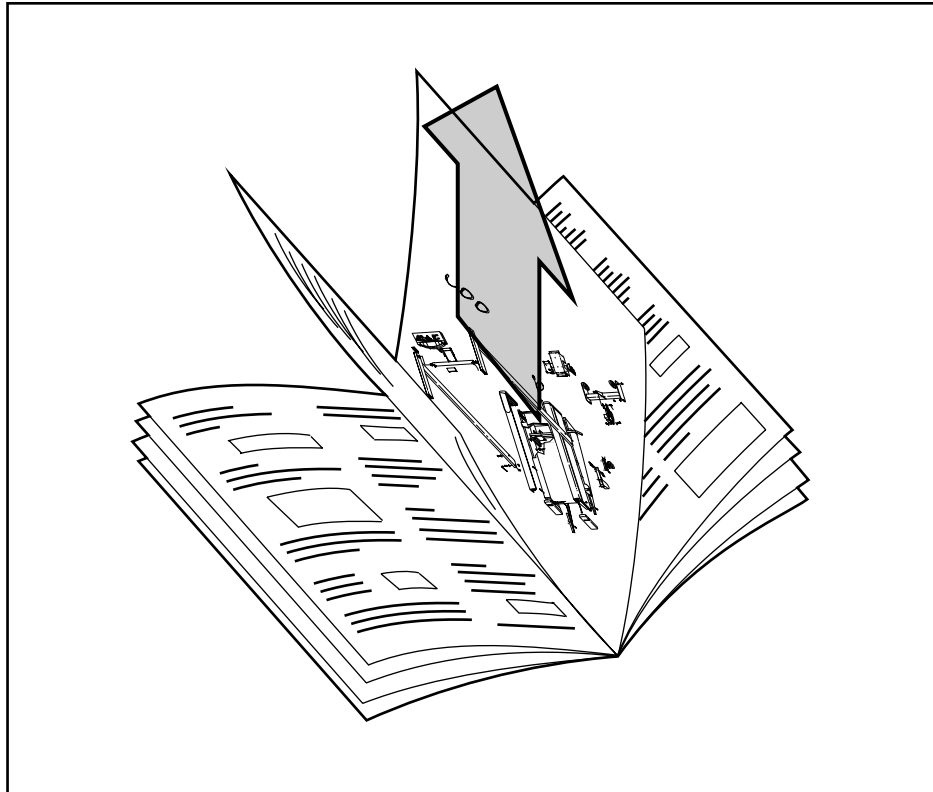

Note: Specifications are subject to change without notice. For information about ordering replacement parts, see the back cover of the User's Manual.

PART LIST—Model No. WLTL48410

R0801A

Key No.	Qty.	Description	Key No.	Qty.	Description
1	1	Left Handrail	54	1	Power Cord
2	1	Key/Clip	55	1	Power Cord Grommet
3	2	Incline Leg Pivot Bolt	56	1	Circuit Breaker
4	2	Battery Cover	57	2	Frame Pivot Washer
5	1	Foot Grip (Left)	58	2	Frame Pivot Bolt
6	1	Lift Motor	59	1	Latch Decal
7	1	Rear Roller	60	1	Motor Belly Pan
8	1	Speed Potentiometer	61	2	Cable Tie Clamp
9	1	Speed Control Knob	62	4	Rear Platform Screw
10*	1	Console Assembly	63	3	Releasable Tie
11	1	Upright	64	1	Choke
12	1	Motor Belt	65	2	Belt Guide
13	7	Small Screw	66	4	Belly Pan Fastener
14	1	Storage Latch	67	1	Walking Belt
15	2	Controller Screw	68	1	Walking Platform
16	7	8" Cable Tie	69	1	Belly Pan
17	4	Incline Leg Nut/Base Nut	70	2	Cage Nut
18	1	Pulley/Flywheel/Fan	71	1	Incline Wire Harness
19	1	Motor	72	1	Upright Grommet
20*	1	Motor/Pulley/Flywheel/Fan	73	4	Isolator Screw
21	1	Wire Harness	74	1	Allen Wrench
22	3	Motor Pivot Nut	75	1	Frame
23	1	Motor Hood	76	1	Front Endcap (Left)
24	1	Hood Shield	77	2	Incline Wheel Bolt
25	11	Utility Screw	78	1	Rear Pad (Left)
26	1	Controller	79	1	Rear Pad (Right)
27	1	Motor Swivel Bolt	80	12	Screw
28	1	Motor Tension Nut	81	1	Ground Wire
29	1	Motor Tension Star Washer	82	1	Incline Leg
30	1	Motor Tension Washer	83	2	Rear Roller Adj. Bolt
31	2	Motor Tension Bolt	84	1	Rear Endcap
32	1	Incline Stop Bracket	85*	2	Extension Leg Assembly
33	10	Belly Pan Screw/Guide Screw	86	1	Foot Grip (Right)
34	2	Extension Leg	87	2	Belly Pan Screw
35	1	Hood Shield Plug	88	1	Right Handrail
36	2	Wheel Bolt	89	2	Short Handrail Bolt
37	2	Wheel	90	1	Front Endcap (Right)
38	4	Wheel Nut/Lift Nut	91	2	Handrail Bolt
39	5	Washer	92	2	Handrail Washer
40	6	Base Pad	93	2	Handrail Nut
41	1	Belt Bracket	94	1	Incline Motor Bolt
42	1	Latch Catch	95	2	Front Isolator
43	1	Reed Switch Clip	96	2	Front Isolator Screw
44	1	Reed Switch	97	11	Endcap Screw/Console Screw
45	1	Magnet	98	4	Belt Guide Screw
46	1	Console Base	#	1	8" White Wire, Pigtail
47	2	Frame Spacer	#	1	4" Blue Wire, M/F
48	4	Platform Screw	#	1	4" Red Wire, M/F
49	2	Center Isolator	#	1	User's Manual
50	1	Front Roller/Pulley			
51	1	Front Roller Adj. Bolt			
52	2	Incline Wheel			
53	2	Extension Leg Screw			

* Includes all parts shown in the box

These parts are not illustrated

EXPLODED DRAWING—Model No. WLTL48410

R0801A

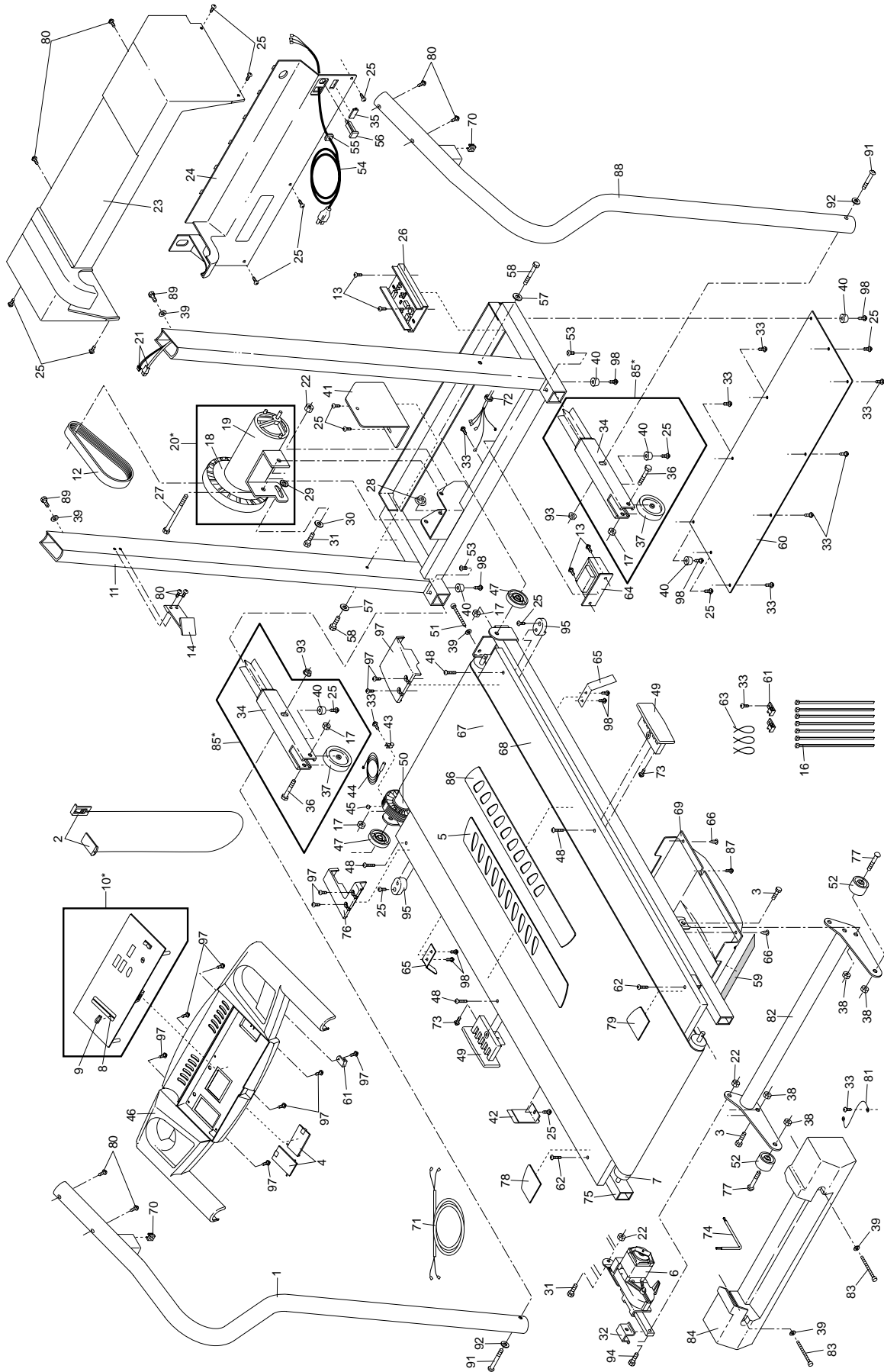

ORDERING REPLACEMENT PARTS

To order replacement parts, simply call our Customer Service Department toll-free at 1-800-999-3756, Monday through Friday, 6 a.m. until 6 p.m. Mountain Time (excluding holidays). To help us assist you, please be prepared to give the following information when calling:

- The MODEL NUMBER of the product (WLTL48410)
- The NAME of the product (WESLO CADENCE® 40.8 CT treadmill)
- The SERIAL NUMBER of the product (see the front cover of this manual)
- The KEY NUMBER and DESCRIPTION of the desired part(s) (see the PART LIST and the EXPLODED DRAWING in the center of this manual).

WESLO is a registered trademark of ICON Health & Fitness, Inc.

LIMITED WARRANTY

ICON Health & Fitness, Inc. (ICON), warrants this product to be free from defects in workmanship and material, under normal use and service conditions, for a period of ninety (90) days from the date of purchase. This warranty extends only to the original purchaser. ICON's obligation under this warranty is limited to replacing or repairing, at ICON's option, the product through one of its authorized service centers. All repairs for which warranty claims are made must be pre-authorized by ICON. This warranty does not extend to any product or damage to a product caused by or attributable to freight damage, abuse, misuse, improper or abnormal usage or repairs not provided by an ICON authorized service center, products used for commercial or rental purposes, or products used as store display models. No other warranty beyond that specifically set forth above is authorized by ICON.

ICON is not responsible or liable for indirect, special or consequential damages arising out of or in connection with the use or performance of the product or damages with respect to any economic loss, loss of property, loss of revenues or profits, loss of enjoyment or use, costs of removal, installation or other consequential damages of whatsoever nature. Some states do not allow the exclusion or limitation of incidental or consequential damages. Accordingly, the above limitation may not apply to you.

The warranty extended hereunder is in lieu of any and all other warranties and any implied warranties of merchantability or fitness for a particular purpose is limited in its scope and duration to the terms set forth herein. Some states do not allow limitations on how long an implied warranty lasts. Accordingly, the above limitation may not apply to you.

This warranty gives you specific legal rights. You may also have other rights which vary from state to state.

ICON HEALTH & FITNESS, INC., 1500 S. 1000 W., LOGAN, UT 84321-9813

Free Manuals Download Website

<http://myh66.com>

<http://usermanuals.us>

<http://www.somanuals.com>

<http://www.4manuals.cc>

<http://www.manual-lib.com>

<http://www.404manual.com>

<http://www.luxmanual.com>

<http://aubethermostatmanual.com>

Golf course search by state

<http://golfingnear.com>

Email search by domain

<http://emailbydomain.com>

Auto manuals search

<http://auto.somanuals.com>

TV manuals search

<http://tv.somanuals.com>