

Model No. TL10.0i

CADENCE™

POWER INCLINE

10.0i



Assembly

Warranty

Operation and Adjustments

Exercise Guidelines

Maintenance and Storage

Part Ordering Information

OWNER'S MANUAL

weslo, inc™

A Division of **weider**® Health and Fitness

Patent Pending

CAUTION: *Read all instructions carefully before using this product. Retain this Owner's Manual for reference.*

Part No. 046324 11/89

LIMITED WARRANTY

Weslo, Inc. ("Weslo") warrants this product to be free from defects in workmanship and material, under normal use and service conditions, for a period of ninety (90) days from the date of purchase. This warranty extends only to the original purchaser. Weslo's obligation under this Warranty is limited to replacing or repairing, at Weslo's option, the product at one of its authorized service centers. All products for which warranty claim is made must be received by Weslo at one of its authorized service centers with all freight and other transportation charges prepaid, accompanied by sufficient proof of purchase. All returns must be pre-authorized by Weslo. Pre-authorization may be obtained by calling Weslo's Customer Service Department at 1-800-99WESLO. This warranty does not extend to any product or damage to a product caused by or attributable to freight damage, abuse, misuse, improper or abnormal usage or repairs not provided by a Weslo authorized service center or for products used for commercial or rental purposes. No other warranty beyond that specifically set forth above is authorized by Weslo.

WESLO IS NOT RESPONSIBLE OR LIABLE FOR INDIRECT, SPECIAL OR CONSEQUENTIAL DAMAGES ARISING OUT OF OR IN CONNECTION WITH THE USE OR PERFORMANCE OF THE PRODUCT OR OTHER DAMAGES WITH RESPECT TO ANY ECONOMIC LOSS, LOSS OF PROPERTY, LOSS OF REVENUES OR PROFITS, LOSS OF ENJOYMENT OR USE, COSTS OF REMOVAL, INSTALLATION OR OTHER CONSEQUENTIAL DAMAGES OF WHATSOEVER NATURE. SOME STATES DO NOT ALLOW THE EXCLUSION OR LIMITATION OF INCIDENTAL OR CONSEQUENTIAL DAMAGES. ACCORDINGLY, THE ABOVE LIMITATION MAY NOT APPLY TO YOU.

THE WARRANTY EXTENDED HEREUNDER IS IN LIEU OF ANY AND ALL OTHER WARRANTIES AND ANY IMPLIED WARRANTIES OF MERCHANTABILITY OR FITNESS FOR A PARTICULAR PURPOSE IS LIMITED IN ITS SCOPE AND DURATION TO THE TERMS SET FORTH HEREIN. SOME STATES DO NOT ALLOW LIMITATIONS ON HOW LONG AN IMPLIED WARRANTY LASTS. ACCORDINGLY, THE ABOVE LIMITATION MAY NOT APPLY TO YOU.

This warranty gives you specific legal rights. You may also have other rights which vary from state to state.

WESLO INC., P.O. BOX 10, LOGAN, UT 84321

WARNING: Before beginning this or any exercise program consult your physician. This is especially important for individuals over the age of 35 or persons with pre-existing health problems. Read all instructions before using. Weslo assumes no responsibility for personal injury or property damage sustained by or through the use of this Weslo product.

CADENCE 10.0i

Warranty	2	Maintenance and Storage	7
Safety Precautions	3	Conditioning Guidelines	8
Before You Begin	4	Part List	10
Assembly	5	Exploded Drawing	11
Operation and Adjustment	6	Part Ordering Information	12

IMPORTANT SAFETY PRECAUTIONS

WARNING: To reduce the risk of burns, fire, electric shock or injury to persons, read the following important safety precautions and information before operating the treadmill.

1. Position the treadmill on a clear, level surface with a minimum of 8 feet of clearance behind the treadmill. Do not place the treadmill on thick carpet, near water or outdoors.
2. Plug the power cord directly into a grounded circuit carrying 12 or more amps. No other appliance should be on the same circuit. (See the OPERATION section of this manual for proper grounding instructions.) Keep the power cord away from heated surfaces. If an extension cord is required, use only a 14-gauge, general-purpose cord of six to ten feet in length with a three-wire conductor.
3. Never operate the treadmill if the cord or plug are damaged, or if the treadmill is not working properly. (Refer to the BEFORE YOU BEGIN section of this manual for instructions if the treadmill is not working properly.)
4. Never start the treadmill while you are standing on the walking belt. Always hold the handrail when walking or running on the treadmill.
5. Keep small children away from the treadmill during operation. Never leave the treadmill unattended while it is running.
6. Always wear appropriate clothing when using the treadmill. Do not wear flowing clothing that could become caught in the treadmill. *Always wear running or aerobic shoes. Never use the treadmill with bare feet, wearing only stockings, or in sandals.* Athletic support clothes are also recommended for both men and women.
7. Never drop or insert any object into any opening.
8. Do not operate where aerosol (spray) products are being used or where oxygen is being administered.
9. Use this treadmill only as described in this manual.
10. Always unplug the power cord before performing the maintenance and adjustment procedures described in this manual. Never remove the motor hood unless instructed to do so by an authorized service representative. Servicing other than the procedures described in this manual should be performed by an authorized service representative only.

SAVE THESE INSTRUCTIONS.

INTRODUCTION

Thank you for purchasing a Weslo CADENCE 10.0i Power Incline Treadmill. The CADENCE 10.0i combines advanced technology with innovative design to let you enjoy one of the best forms of cardiovascular exercise at your convenience, in the privacy of your home.

The CADENCE 10.0i is truly a state-of-the-art treadmill, offering many exclusive features for an effective and enjoyable workout. The CADENCE 10.0i incorporates a card-operated safety power switch, console-mounted power incline control, electronic speed control and a microprocessor-based electronic monitor.

This manual is designed to help you understand the easy assembly and operation of this treadmill. Basic fitness guidelines are included to help you get started with your exercise program. Please read this manual carefully before initial use of the treadmill. If you have additional questions regarding operation, maintenance, or the warranty, please call our Customer Service Department toll-free at 1-800-99WESLO (1-800-999-3756), (in Canada 1-800-824-8949) during business hours: Monday - Friday, 6 a.m. - 6 p.m. Mountain Time.

In all correspondence regarding this product, refer to the model number, and the serial number (located on the front of the treadmill frame). Write the serial number in the box to the right for easy reference.

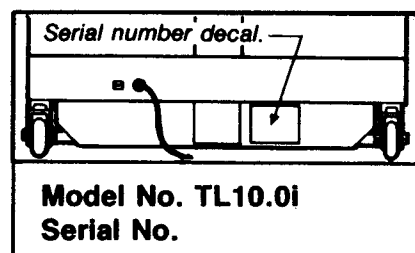

Please review the Exploded Drawing and the Part List in this manual before calling. If possible, place your telephone near the treadmill for easy reference. To help you clearly understand the descriptions in this manual, examine the drawing below and familiarize yourself with the parts identified.

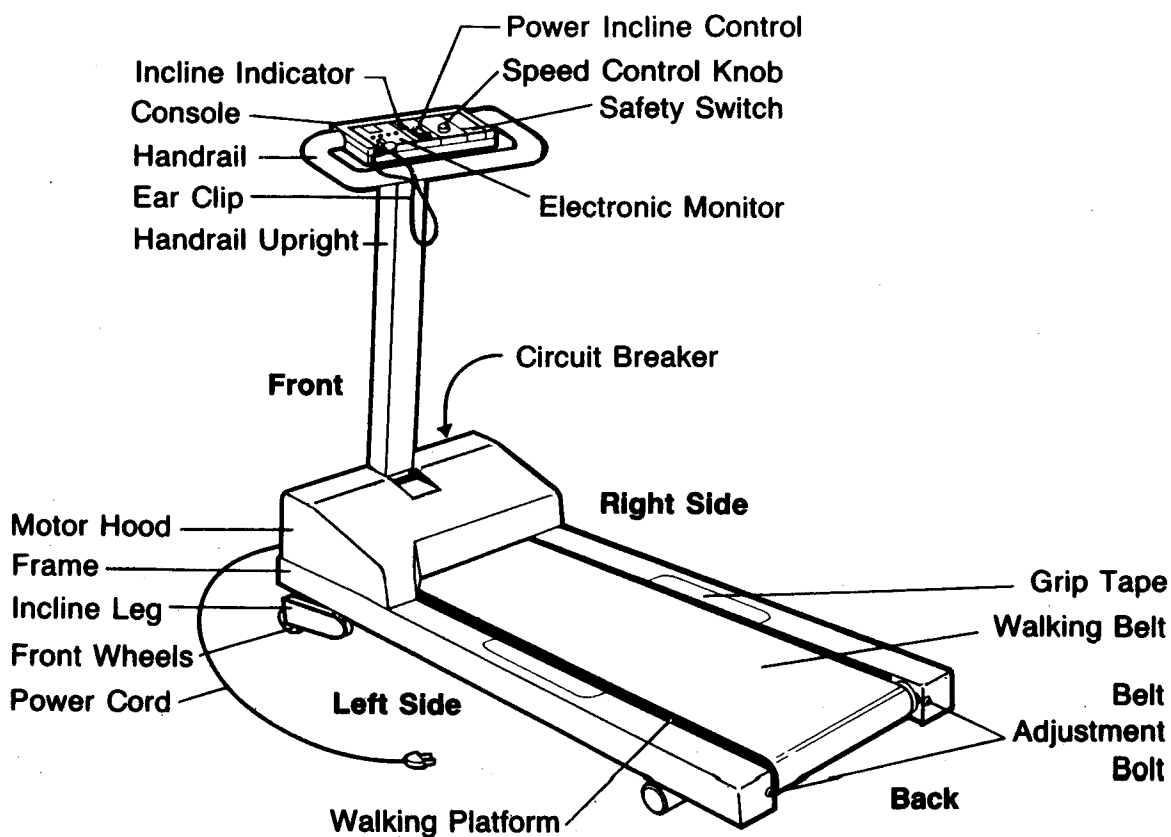

ASSEMBLY

Please read all instructions before beginning assembly. Refer to the Exploded Drawing and the Part List on pages 10-11 for help in part identification. Assembly can be completed using the tool provided.

1. Set the treadmill in a clear area on the floor and remove all packing materials. Make sure that all parts are included before disposing of the packing materials.

2. Place the Knob Washer (28) on the end of the Upright Knob (29). Raise the Handrail Upright (22) to the vertical position and insert the Knob into the Handrail Upright. Tighten the Knob firmly.

3. Plug the Sensor Wire (76) into the back of the Electronic Monitor (7) and press the Monitor firmly into the Console (10).

4. Make sure that all parts are tightened securely before operating the treadmill.

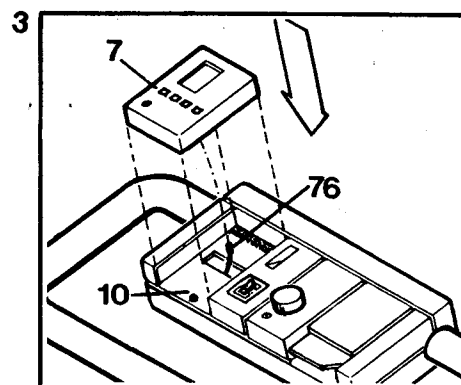
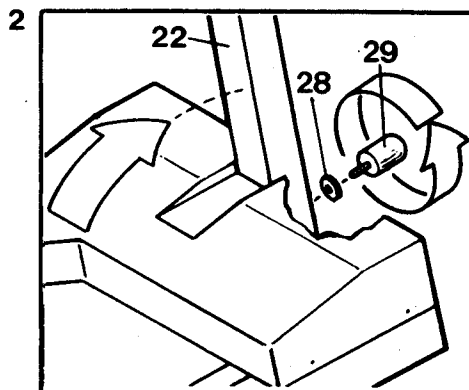

OPERATION AND ADJUSTMENT

GROUNDING INSTRUCTIONS

This product must be grounded. If it should malfunction or break down, grounding provides a path of least resistance for electric current to reduce the risk of electric shock. This product is equipped with a cord having an equipment-grounding conductor and a grounding plug. **The plug must be plugged into an appropriate outlet that is properly installed and grounded in accordance with all local codes and ordinances.**

DANGER: Improper connection of the equipment-grounding conductor can result in a risk of electric shock. Check with a qualified electrician or serviceman if you are in doubt as to whether the product is properly grounded. Do not modify the plug provided with the product - if it will not fit the outlet, have a proper outlet installed by a qualified electrician.

This product is for use on a nominal 120-volt circuit, and has a grounding plug that looks like the plug illustrated in Drawing 1. A temporary adapter that looks like the adapter illustrated in Drawing 2 may be used to connect this plug to a 2-pole receptacle as shown in Drawing 2 if a properly grounded outlet is not available. The temporary adapter should be used only until a properly grounded outlet (Drawing 1) can be installed by a qualified electrician. The green colored rigid ear, lug, or the like extending from the adapter **must be** connected to a permanent ground such as a properly grounded outlet box cover. Whenever the adapter is used it **must be** held in place by a metal screw. **Some 2-pole receptacle outlet box covers are not grounded. Contact a qualified electrician to determine if the outlet box cover is grounded before using an adapter.**

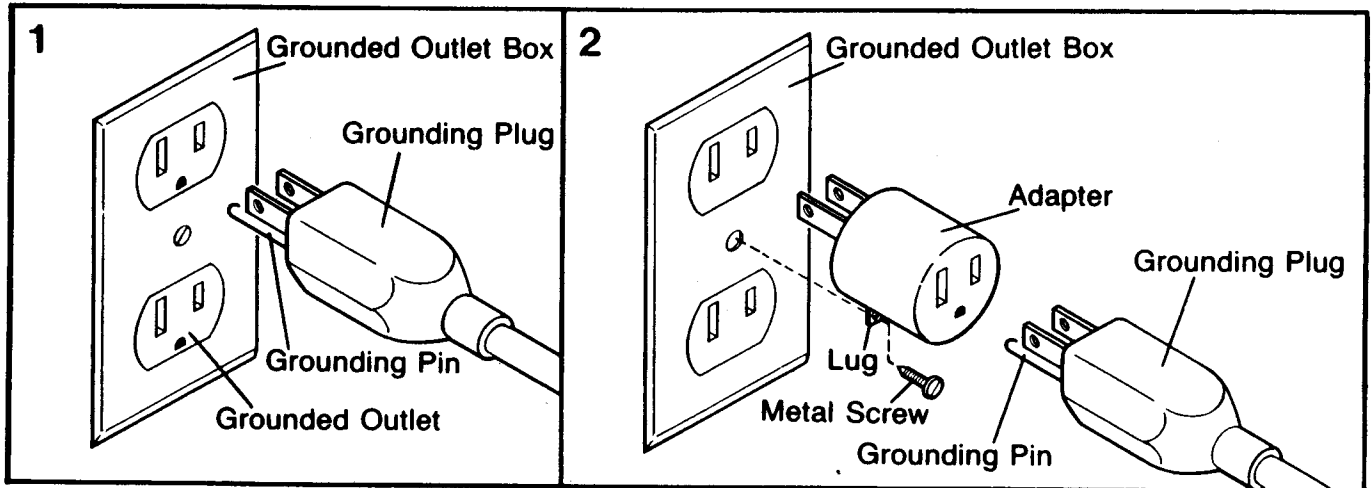

TREADMILL OPERATION – Follow the steps below each time you use the treadmill.

1. Step onto the treadmill and place your feet on the Grip Tape on the sides of the Frame.
2. Insert the Safety Card into the Safety Switch and press the Switch down to start the treadmill. (If the Safety Card becomes lost, a credit card can be used. The treadmill cannot be started unless a card is inserted.) **Do not lift the Switch or the Switch will break.**
3. Turn the Speed Control Knob counterclockwise until it stops, and then clockwise until the Walking Belt is moving at slow speed.
4. Holding the Handrail firmly, step onto the Walking Belt and begin walking.
5. Slowly turn the Speed Control Knob until the desired speed is reached. (Turning the knob clockwise increases the speed. Turning the knob counterclockwise decreases the speed.)
6. To turn the treadmill off, step onto the Grip Tape and press down on the Safety Switch.

Instructions for operating the Electronic Monitor can be found in the Operation Guide accompanying this Manual.

INCLINE ADJUSTMENT

To increase or decrease the level of exercise difficulty, the angle of the treadmill can be adjusted using the Power Incline Control on the Console of the treadmill. To raise the angle of the treadmill, rock the Incline Control forward until the desired angle is reached. To lower the treadmill, rock the Incline Control backward.

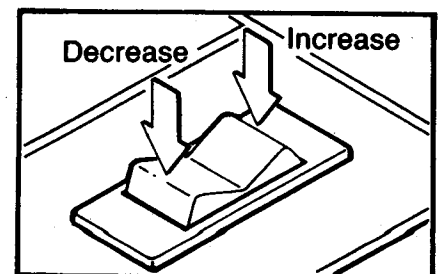

There is an Incline Indicator mounted above the Power Incline Control on the Console. When the bubble in the Indicator is at level 1, the treadmill is at the lowest degree of incline. When the bubble is at level 5, the treadmill is at the highest incline.

The Incline Indicator can be adjusted, if necessary, by lowering the treadmill to the lowest degree of incline, and turning the small Adjustment Screw above the Indicator until the bubble in the Indicator is at level 1.

MAINTENANCE AND STORAGE

This treadmill is designed to be virtually maintenance-free. Check all parts periodically to ensure that they are tightened securely. Outside surfaces of the treadmill can be cleaned using a damp cloth and mild, non-abrasive detergent. Do not allow liquids to come in contact with the console.

WALKING BELT ADJUSTMENT

To prevent damage to the Walking Belt, always keep the Belt centered during operation. Stand beside the treadmill and turn the treadmill on at medium speed. Observe the spaces between the edges of the Walking Belt and the side rails. If the Belt is closer to one side rail than to the other, center the Belt in the following manner:

1. Locate the Belt Adjustment Bolts and the Allen Wrench **Caution: Keep your hands away from the moving Walking Belt or serious injury could result.**
2. A. IF THE BELT HAS SHIFTED TO THE LEFT SIDE: turn the adjustment bolt on the left side clockwise and the adjustment bolt on the right side counterclockwise 1/8 of a turn at a time until the belt moves to the center.
B. IF THE BELT HAS SHIFTED TO THE RIGHT SIDE: turn the adjustment bolt on the left side counterclockwise and the adjustment bolt on the right side clockwise 1/8 of a turn at a time until the belt moves to the center.
3. Walk on the treadmill for 3-4 minutes to ensure that the belt is running centered.

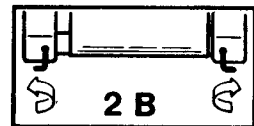
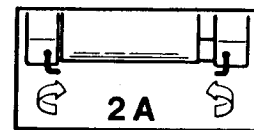

If the walking belt slips during operation, the tension on the belt may need to be adjusted. Turn both rear adjustment bolts clockwise an equal amount until the belt no longer slips. Be careful to keep the belt centered. **Do not overtighten the Bolts.** Overtightening may stretch the Belt, cause excessive Roller noise and reduce Motor performance.

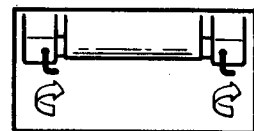

The allen wrench can be stored on one of the rear adjustment brackets using the self-adhesive clamp included.

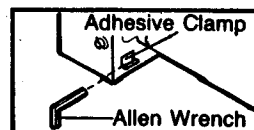

To check for proper Walking Belt tightness, unplug the power cord and lift the sides of the Belt. You should be able to lift the sides approximately 2-3 inches off of the Walking Platform. The center of the Belt should remain just at the surface of the platform, causing the Belt to bow.

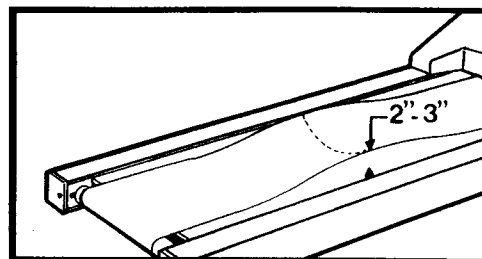

CIRCUIT BREAKER

If the treadmill stops or will not start, check the Circuit Breaker located on the front of the Frame near the Power Cord. The Circuit Breaker is designed to protect the electrical system. If the Circuit Breaker has tripped, the switch will protrude as shown. To reset the Circuit Breaker, allow the treadmill to cool for a few minutes and then push the switch back in.

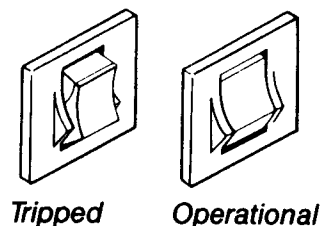

SILICONE APPLICATION

To maintain the low-friction quality of the Walking Belt and reduce treadmill wear, a **non-oil, non-petroleum base silicone lubricant should be applied generously to the Walking Platform.** (Silicone lubricant is available at most hardware and automotive stores.) It is **very important** to apply silicone lubricant before initial use of the treadmill. Lubricant should also be applied after every 10 hours of use or whenever a decrease in performance is noticed. **Unplug the Power Cord**, lift each side of the Walking Belt and apply the lubricant generously to the area indicated in the drawing.

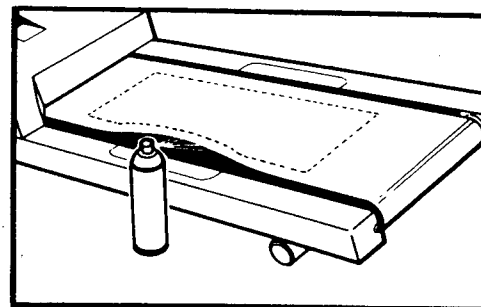

STORAGE

Always unplug the Power Cord when the treadmill is not in use. To convert the treadmill to the storage position, loosen the Upright Locking Knob and carefully lower the Handrail Upright onto the treadmill. Always remove the batteries from the Electronic Monitor when storing the treadmill for extended periods of time.

CONDITIONING GUIDELINES

The following guidelines will help you to plan and regulate your personal fitness program. **However, before beginning this or any exercise program, consult your physician.** Remember that adequate rest and good nutrition are also essential to the success of any fitness program.

EXERCISE INTENSITY

To maximize health benefits from exercising, your level of exertion must exceed mild demands while falling short of causing breathlessness and fatigue. The proper level of exertion can be determined using the heart rate as a guide. For effective aerobic exercise the heart rate must be maintained at a level between 70% and 85% of your maximum heart rate. This is your "Training Zone."

You can determine your Training Zone by consulting the table below. Training Zones are given for both conditioned and unconditioned persons. Use the column that is appropriate for you.

AGE	UNCONDITIONED TRAINING ZONE (BEATS/MIN)	CONDITIONED TRAINING ZONE (BEATS/MIN)	AGE	UNCONDITIONED TRAINING ZONE (BEATS/MIN)	CONDITIONED TRAINING ZONE (BEATS/MIN)
20	138-167	133-162	55	127-155	122-149
25	136-166	132-160	60	126-153	121-147
30	135-164	130-158	65	125-151	119-145
35	134-162	129-156	70	123-150	118-144
40	132-161	127-155	75	122-147	117-142
45	131-159	125-153	80	120-146	115-140
50	129-156	124-150	85	118-144	114-139

During the first few weeks of your exercise program you should keep your heart rate near the low end of your Training Zone. Over the course of a few months, gradually increase your heart rate until you reach the high end of your Training Zone. As your condition improves, a greater workload will be required in order to raise your heart rate to your Training Zone.

You can measure your heart rate and find the proper level of exercise intensity using the electronic monitor (see the ELECTRONIC MONITOR OPERATION GUIDE). Set the TIME SET function for 4 minutes. Press the "START/STOP" key and exercise at a comfortable pace until the 4 minutes elapse. Immediately measure your heart rate using the PULSE function. If your heart rate is below your Training Zone, increase your level of exertion. If your heart rate is too high, reduce your level of exertion.

EXERCISE PATTERN

Each workout should consist of a basic 5-step pattern.

1. At rest
2. Warm-up
3. Training Zone exercise
4. Cool-down
5. At rest

Warming up is an important part of your workout and should not be taken lightly. Warming up prepares the body for more strenuous exercise by increasing the circulation, delivering more oxygen to the muscles, and raising the body temperature. This can be done by stretching and light calisthenics for 5-10 minutes prior to exercising.

Begin exercising at a light pace for a few minutes. Then increase the intensity to raise your heart rate to your Training Zone for a period of 20-30 minutes.

Cooling down after vigorous exercise is important in aiding circulation and preventing soreness. 5-10 minutes of light exercise or stretching will allow the body to cool down.

EXERCISE FREQUENCY

To maintain or improve your condition you must work out 2-3 times per week following the pattern described above. A day of rest between workouts is recommended. After several months of exercise the number of workouts can be increased to 4-5 times per week. The key to a successful program is REGULAR EXERCISE.

PART LIST - Model No. TL10.0i

Rev. 11/89

Key No.	Qty.	Description	Key No.	Qty.	Description
1	4	Console Screw	43	1	Motor Connect Wire
2	1	Foam Handgrip	44	2	E-Clip
3	1	Potentiometer Assembly	45	2	Motor Spacer
4	1	On/Off Switch Wire	46	1	Fan
5	1	Power Light	47	1	Front Roller/Pulley
6	1	Power Incline Control/Wire	48	1	Walking Belt
7	1	Electronic Monitor	49	4	Rubber Pad
8	1	Pulse Ear Clip	50	4	Support Spacer
9	1	Clothes Clip	51	6	Support Washer
10	1	Console Assembly	52	6	Support Bolt
11	1	Speed Control Knob	53	2	Wood Support
12	1	Indicator Adjustment Screw	54	2	Rear Leg Endcap
13	1	Incline Indicator	55	15	Small Screw
14	1	Indicator Mounting Screw	56	1	Belt Adjustment Bracket (R)
15	1	Safety Card	57	1	Rear Roller
16	1	Safety Switch	58	1	Adhesive Clamp
17	1	On/Off Switch	59	1	Allen Wrench
18	1	Circuit Breaker	60	3	Adjustment Washer
19	4	Handrail Mounting Washer	61	2	Belt Adjustment Bolt
20	4	Handrail Bolt	62	1	Belt Adjustment Bracket (L)
21	1	Handrail	63	1	Frame
22	1	Handrail Upright	64	2	Grip Tape
23	1	Clevis Pin	65	1	Walking Platform
24	1	Incline Motor	66	1	V-Belt
25	1	Pivot Nut	67	1	Flywheel
26	1	Front Roller Bolt	68	1	Controller
27	4	Pivot Washer	69	1	Cotter Pin
28	1	Upright Knob Washer	70	1	Motor Hood
29	1	Upright Knob	71	6	Platform Bumper
30	1	Pivot Bolt	72	2	Cable Tie
31	1	Incline Motor Pin	73	2	Cable Mount
32	1	Power Cord	74	1	Magnet
33	8	Lock Nut	75	1	Safety Cover
34	2	Rubber Bumper	76	1	Sensor Wire
35	4	Leg Bolt	77	1	Motor Pulley
36	2	Wheel	78	4	Sensor Wire Clip
37	1	Incline Leg	79	4	Motor Mount Bolt
38	6	Hood Mount Anchor	80	4	Motor Mount Washer
39	4	Roller Bushing	81	4	Motor Mount Nut
40	2	Roller Lock	82	1	Grommet
41	4	Roller Lock Screw	#	1	Owner's Manual
42	1	Motor	#	1	Electronic Monitor Guide

Note: “#” indicates a non-illustrated part.

10 See the back cover of this manual for part ordering information.

ORDERING REPLACEMENT PARTS

Replacement parts can be ordered by calling our Customer Service Department toll-free at **1-800-99WESLO (999-3756)**, (in Canada at **1-800-824-8949**) during our regular business hours: Monday - Friday, 6 a.m. - 6 p.m., Mountain Time.

When ordering parts, please be prepared to give the following information.

1. The **MODEL NUMBER OF THE PRODUCT** (TL10.0i).
2. The **NAME OF THE PRODUCT** (CADENCE 10.0i Power Incline Treadmill).
3. The **PART NUMBER OF THE PRODUCT OWNER'S MANUAL** (046324).
4. The **SERIAL NUMBER OF THE PRODUCT** (see page 4 of this manual).
5. The **KEY NUMBER OF THE PART** from the part list in this manual.
6. The **DESCRIPTION OF THE PART** from the part list in this manual.

If possible, place your telephone near the treadmill for reference when calling.

Free Manuals Download Website

<http://myh66.com>

<http://usermanuals.us>

<http://www.somanuals.com>

<http://www.4manuals.cc>

<http://www.manual-lib.com>

<http://www.404manual.com>

<http://www.luxmanual.com>

<http://aubethermostatmanual.com>

Golf course search by state

<http://golfingnear.com>

Email search by domain

<http://emailbydomain.com>

Auto manuals search

<http://auto.somanuals.com>

TV manuals search

<http://tv.somanuals.com>