



WESTELL
VERSALINK™ GATEWAY (MODEL 327W)

USER GUIDE



TABLE OF CONTENTS

1. PRODUCT DESCRIPTION	4
2. SAFETY INSTRUCTIONS	4
3. REGULATORY INFORMATION	5
3.1 FCC Compliance Note	5
3.2 Canada Certification Notice	6
4. NETWORKING REQUIREMENTS	8
5. HARDWARE FEATURES	9
5.1 LED Indicators	9
5.2 Cable Connectors and Switch Locations	10
5.3 Connector Descriptions	11
5.4 Pin-out Descriptions	11
6. INSTALLING THE HARDWARE	12
6.1 Installation Requirements	12
6.2 Before you begin	12
6.3 Microfilters	12
6.4 Hardware Installations	13
7. CONFIGURING VERSALINK FOR INTERNET CONNECTION	17
7.1 Setting Up an Account Profile	17
7.2 Confirming a DSL Sync	22
7.3 Establishing a PPP Session	24
7.4 Disconnecting a PPP Session	26
8. SETTING UP MACINTOSH OS X	27
9. SETTING UP ADVANCED CONFIGURATION	32
10. HOME	33
10.1 Adding Account Profiles	34
10.2 Editing Account Profiles	35
11. STATUS	37
11.1 Connection Summary	37
11.2 About	38
12. CONFIGURATION	39
12.1 Single Static IP – Single IP Address PassThrough	39
12.2 Service Configuration	44
12.3 Firewall Configuration	56
12.4 Wireless Configuration	60



- 12.5 Advanced LAN69
- 12.6 Advanced WAN.....85
- 13. SETTING UP ADVANCED SERVICE CONFIGURATION.....115
 - 13.1 Port Forwarding Ranges of Ports116
 - 13.2 Adding Port Forwarding Ports116
 - 13.3 Port Forwarding Trigger Ports117
 - 13.4 Adding Local Trigger Ports118
 - 13.5 Static NAT119
 - 13.6 Enabling Static NAT120
 - 13.7 Disabling Static NAT.....121
- 14. MAINTENANCE.....123
 - 14.1 Backup/Restore123
 - 14.2 Firewall Log.....124
 - 14.3 Administrative Password126
 - 14.4 Remote Access.....127
 - 14.5 Update Device.....128
- 15. TROUBLESHOOTING133
 - 15.1 System Self Tests133
 - 15.2 Diagnostic Logs135
 - 15.3 Statistics139
 - 15.4 Wireless Statistics142
 - 15.5 Status.....144
- 16. NAT SERVICES150
- 17. TECHNICAL SUPPORT INFORMATION154
- 18. WARRANTY AND REPAIRS154
- 19. PRODUCT SPECIFICATIONS.....155
- 20. SOFTWARE LICENSE AGREEMENT.....156
- 21. PUBLICATION INFORMATION.....157

1. PRODUCT DESCRIPTION

The Westell® VersaLink™ Gateway provides reliable, high-speed, Internet access to your existing small office phone line. Your ADSL connection is “always-on” ending the hassles of dial-up modems and busy signals. Installation is easy ... no tools ... no headaches. Simply connect the hardware, apply power, and perform the simple software configuration for VersaLink and you are on the Internet.

VersaLink™ is capable of data rates hundreds of times faster than a traditional analog modem. But unlike analog modems, VersaLink™ allows you to use the same phone line for simultaneous voice/fax communications and high-speed Internet access, eliminating the need for dedicated phone lines for voice and data needs. VersaLink™ supports a variety of networking interfaces such as wireless 802.11b/g/g+, ADSL, Ethernet and the following optional features:

- VersaPort™: Alternate WAN uplink port
- Layer w/2 QOS with VLAN tagging
- HotSpot
- Simultaneous public/private network support

Hereafter, the Westell® VersaLink™ Gateway will be referred to as “VersaLink” or “Gateway.”

2. SAFETY INSTRUCTIONS

Never install any telephone wiring during a lightning storm.

Never install telephone jacks in wet locations unless the jack is specifically designed for wet locations.

Never touch non-insulated telephone wires or terminals unless the telephone line has been disconnected at the network interface.

Use caution when installing or modifying telephone lines.



Risk of electric shock. Voltages up to 140 Vdc (with reference to ground) may be present on telecommunications circuits.

3. REGULATORY INFORMATION

3.1 FCC Compliance Note

(FCC ID: CH8-327WXX-6)

This equipment has been tested and found to comply with the limits for a Class B digital device, pursuant to Part 15 of the Federal Communication Commission (FCC) Rules. These limits are designed to provide reasonable protection against harmful interference in a residential installation. This equipment generates, uses, and can radiate radio frequency energy, and if not installed and used in accordance with the instructions, may cause harmful interference to radio communications. However, there is no guarantee that interference will not occur in a particular installation. If this equipment does cause harmful interference to radio or television reception, which can be determined by turning the equipment OFF and ON, the user is encouraged to try to correct the interference by one or more of the following measures:

- Reorient or relocate the receiving antenna.
- Increase the separation between the equipment and the receiver.
- Connect the equipment to a different circuit from that to which the receiver is connected.
- Consult the dealer or an experienced radio/TV technician for help.

Modifications made to the product, unless expressly approved by Westell Inc., could void the users' right to operate the equipment.

RF EXPOSURE

This device has been tested and complies with FCC RF Exposure (SAR) limits in typical laptop computer configurations and this device can be used in desktop or laptop computers with side-mounted PCMCIA slots, which can provide 1 cm separation distance from the antenna to the body of the user or a nearby person. Thin laptop computers may need special attention to maintain antenna spacing while operating. This device cannot be used with handheld PDAs (personal digital assistants). Use in other configurations may not ensure compliance with FCC RF exposure guidelines. This device and its antenna must not be co-located or operate in conjunction with another antenna or transmitter.

PART 68 – COMPLIANCE REGISTRATION

This equipment (Model 327W) complies with Part 68 of the FCC rules and the requirements adopted by the ACTA. A label on the bottom of this equipment contains, among other information, the Ringer Equivalence Number (REN) and the product identifier. For products approved after July 23, 2001 the product identifier is in the format US:AAAEQ##TXXXX. The digits represented by ## are the REN without a decimal point (e.g. 03 is a REN of 0.3). The REN is used to determine the number of devices that may be connected to a telephone line. For earlier products, the REN is separately shown on the label. If requested, this number must be provided to the telephone company.

Excessive RENs on a telephone line may result in the devices not ringing in response to an incoming call. In most, but not all areas, the sum of RENs should not exceed five (5.0). To be certain of the number of devices that may be connected to a line, as determined by the total RENs, contact the local telephone company.

This equipment is designated to connect to the telephone network or premises wiring using a compatible modular jack that is Part 68 compliant. An FCC compliant telephone cord and modular plug is provided with the equipment. See the Installation Information section of this User Guide for details.



A plug and jack used to connect this equipment to the premises wiring and telephone network must comply with the applicable FCC Part 68 rules and requirements adopted by the ACTA. A compliant telephone cord and modular plug is provided with this product. It is designed to be connected to a compatible modular jack that is also compliant. See installation instruction for details.

If this terminal equipment (Model 327W) causes harm to the telephone network, the telephone company may request you to disconnect the equipment until the problem is resolved. The telephone company will notify you in advance if temporary discontinuance of service is required. If advance notification is not practical, the telephone company will notify you as soon as possible. You will be advised of your right to file a complaint with the FCC if you believe such action is necessary.

If you experience trouble with this equipment (Model 327W), do not try to repair the equipment yourself. The equipment cannot be repaired in the field. Contact your ISP, or contact the original provider of your DSL equipment.

The telephone company may make changes to their facilities, equipment, operations, or procedures that could affect the operation of this equipment. If this happens, the telephone company will provide advance notice in order for you to make the modifications necessary to maintain uninterrupted service.

If your home has specially wired alarm equipment connected to the telephone line, ensure that the installation of this equipment (Model 327W) does not disable your alarm equipment. If you have questions about what will disable alarm equipment, consult your telephone company or a qualified installer.

This equipment cannot be used on public coin phone service provided by the telephone company. Connection of this equipment to party line service is subject to state tariffs.

3.2 Canada Certification Notice

The Industry Canada label identifies certified equipment. This certification means that the equipment meets certain telecommunications network protective, operations and safety requirements as prescribed in the appropriate Terminal Equipment Technical Requirements document(s). The department does not guarantee the equipment will operate to the user's satisfaction.

This equipment meets the applicable Industry Canada Terminal Equipment Technical Specification. This is confirmed by the registration number. The abbreviation, IC, before the registration number signifies that registration was performed based on a Declaration of Conformity indicating that Industry Canada technical specification were met. It does not imply that Industry Canada approved the equipment. The Ringer Equivalence Number (REN) is 0.0. The Ringer Equivalence Number that is assigned to each piece of terminal equipment provides an indication of the maximum number of terminals allowed to be connected to a telephone interface. The termination on an interface may consist of any combination of devices subject only to the requirement that the sum of the Ringer Equivalence Numbers of all the devices does not exceed five.

Before installing this equipment, users should ensure that it is permissible to be connected to the facilities of the local Telecommunication Company. The equipment must also be installed using an acceptable method of connection. The customer should be aware that compliance with the above conditions may not prevent degradation of service in some situations. Connection to a party line service is subject to state tariffs. Contact the state public utility commission, public service commission, or corporation commission for information.

If your home has specially wired alarm equipment connected to the telephone line, ensure that the installation of this equipment (Model 327W) does not disable your alarm equipment. If you have questions about what will disable alarm equipment, consult your telephone company or a qualified installer.

If you experience trouble with this equipment (Model 327W), do not try to repair the equipment yourself. The equipment cannot be repaired in the field and must be returned to the manufacturer. Repairs to certified equipment

should be coordinated by a representative, and designated by the supplier. Refer to section 18 in this User Guide for further details.

The termination on an interface may consist of any combination of devices subject only to the requirement that the sum of the Ringer Equivalence Numbers of all the devices does not exceed five.

Users should ensure, for their own protection, that the electrical ground connections of the power utility, telephone lines, and internal, metallic water pipe system, if present, are connected together. This precaution may be particularly important in rural areas.



Users should not attempt to make such connections themselves, but should contact the appropriate electrical inspection authority, or electrician, as appropriate.

4. NETWORKING REQUIREMENTS

The following system specifications are required for optimum performance of the VersaLink™ via 10/100 Base-T or Wireless installations.

CONNECTION TYPE	MINIMUM SYSTEM REQUIREMENTS	NETWORKING SCHEME
ETHERNET	<ul style="list-style-type: none"> • Pentium® or equivalent class machines • Microsoft® Windows® (95, 98, ME, 2000, NT 4.0, or XP) Macintosh® OS X, or Linux installed • 64 MB RAM (128 MB recommended) • 10 MB of free hard drive space • TCP/IP Protocol stack installed • 10/100 Base-T Network Interface Card (NIC) • Computer Operating System CD-ROM on hand 	Networking via 10/100 Base-T Ethernet requires an available Ethernet port with a 10/100 Base-T Network Interface Card (NIC) installed.
WIRELESS IEEE 802.11g	<ul style="list-style-type: none"> • Pentium® or equivalent class machines • Microsoft® Windows® (98, ME, 2000, or XP) or Macintosh® OS X installed • Computer Operating System CD-ROM on hand • Internet Explorer 4.x or Netscape Navigator 4.x or higher • 64 MB RAM (128 MB recommended) • 10 MB of free hard drive space • An available IEEE 802.11b/g/g+ PC adapter 	Networking via Wireless or other 802.11b/g/g+ capable network adapter card.

5. HARDWARE FEATURES

5.1 LED Indicators

This section explains the LED States and Descriptions. LED indicators are used to verify the unit's operation and status.

LED States and Descriptions

LED	State	Description
POWER	Solid Green	Modem power is ON.
	OFF	Modem power is OFF.
	Solid Red	POST (Power On Self Test), Failure (not bootable) or Device Malfunction. NOTE: The Power LED should be red no longer than two seconds after the power on self test passes.
ETHERNET (E1, E2, E3, E4)	Solid Green	Powered device is connected to the associated port (includes devices with wake-on LAN capability where slight voltage is supplied to an Ethernet connection). NOTE: When using the optional uplink port (E1), Ethernet LAN connection is limited to E2, E3, and E4.
	Flashing Green	10/100 Base-T LAN activity is present (traffic in either direction)
	OFF	Modem power is OFF, no cable or no powered device is connected to the associated port.
WIRELESS	Solid Green	Link Established.
	Flashing Green	Wireless LAN activity is present (traffic in either direction).
	OFF	Modem power is OFF or No Link.
DSL	Solid Green	Good DSL sync.
	Flashing Green	DSL attempting to sync.
	OFF	Modem power is OFF.
INTERNET	Solid Green	Internet link established.
	Flashing Green	IP connection established and IP Traffic is passing through device (in either direction). NOTE: If the IP or PPP session is dropped due to an idle timeout, the light will remain solid green, if an ADSL connection is still present. If the session is dropped for any other reason, the light is turned OFF. The light will turn red when it attempts to reconnect and DHCP or PPP fails).
	Solid Red	Device attempted to become IP connected and failed (no DHCP response, no PPP response, PPP authentication failed, no IP address from IPCP, etc.).
	OFF	Modem power is OFF, Modem is in Bridge Mode, or the connection is not present.

NOTE: Safe Boot is reflected when the Power and Internet LEDs are both Red and all other LEDs are off.

5.2 Cable Connectors and Switch Locations

- DSL connector (RJ-11)
- Reset button
- (4) Ethernet connector (RJ-45) with optional uplink port

NOTE: When using the optional uplink port (E1), Ethernet LAN connection is limited to E2, E3, and E4.

- Power connector (barrel)
- ON/OFF Switch
- Wireless IEEE 802.11b/g SMA connector and antenna

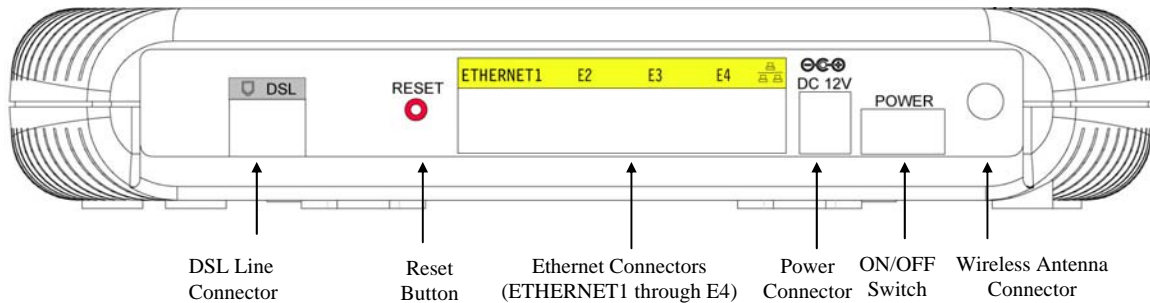

NOTE: When using the optional uplink port (E1), Ethernet LAN connection is limited to E2, E3, and E4. The UPLINK feature is optional. If UPLINK is not enabled, VersaLink will use DSL and wireless only.



VersaLink Model 327W Rear View

5.3 Connector Descriptions

The following chart displays the connector types.

SYMBOL	NAME	TYPE	FUNCTION
	DSL LINE	6-pin RJ-11 modular jack	Connects to an ADSL-equipped telephone jack or DSL connection of a POTS splitter.
	ETHERNET	8-pin (RJ-45) modular jack	Connects the Ethernet device to the PC.
DC 12V	POWER	Barrel connector	Power source.
Wireless	ANTENNA	SMA connector and antenna	Connects to wireless IEEE 802.11b/g/+

5.4 Pin-out Descriptions

The following tables list the pin-out descriptions.

DSL Pin-outs

Pin-out	Description
1, 2, 5, 6	Not Used
3	DSL Tip
4	DSL Ring

Ethernet/Optional Uplink Port Pin-outs

Pin-out	Description
1	Rx+
2	Rx-
3	Tx+
4,5,7,8	Not Used
6	Tx-

6. INSTALLING THE HARDWARE

6.1 Installation Requirements

To install VersaLink™, you will need the following:

- A Network Interface Card (NIC) installed in your PC, or
- An IEEE 802.11b/g adapter

NOTE: Internet service provider subscriber software and connection requirements may vary. Consult your ISP for installation instructions. Please wait until you have received notification from your ISP that your DSL line has been activated before installing VersaLink™ and the software.

6.2 Before you begin

Make sure that your kit contains the following items:

- Westell VersaLink™ Gateway
- Power Supply
- RJ-45 Ethernet cable
- RJ-11 Phone cable
- SMA Antenna
- Westell CD-ROM containing User Guide in PDF format
- Quick Start Guide

6.3 Microfilters

ADSL signals must be blocked from reaching each telephone, answering machine, fax machine, computer modem or any similar conventional device. Failure to do so may degrade telephone voice quality and ADSL performance. Install a microfilter if you desire to use the DSL-equipped line jack for telephone, answering machine, fax machine or other telephone device connections. Microfilter installation requires no tools or telephone rewiring. Just unplug the telephone device from the baseboard or wall mount and snap in a microfilter, next snap in the telephone device. You can purchase microfilters from your local electronics retailer, or contact the original provider of your DSL equipment.



6.4 Hardware Installations

NOTE: If you are using VersaLink™ in conjunction with an Ethernet Hub or Switch, refer to the manufacturer's instructions for proper installation and configuration. When using a Microfilter, be certain that the DSL phone cable is connected to the "DSL/HPN" non-filtered jack. Please wait until you have received notification from your ISP that your DSL line has been activated before installing VersaLink. **Westell recommends the use of a surge suppressor to protect equipment attached to the power supply.**

6.4.1 Installation via 10/100 Base-T Ethernet



NOTE: Before you connect via 10/100 Base-T, you must have an available Ethernet card installed in your computer. If your Ethernet card does not auto-negotiate, you must set it to half duplex. Refer to the Ethernet card manufacturer's instructions for installing and configuring your Ethernet card.

1. Connect the power supply cord to the power connector marked **DC 12V** on the rear panel of VersaLink. Plug the other end of the power supply into a wall socket, and then turn on the modem.
2. Connect the DSL phone cable from the connector marked  on the rear panel of VersaLink to the DSL-equipped telephone line jack on the wall. **IMPORTANT:** Do not use a DSL filter on this connection. You must use the phone cord that was provided with the kit.
3. Connect the yellow Ethernet cable from any one of the Ethernet jacks marked  on the rear panel of VersaLink to the Ethernet port on your computer. **Repeat this step to connect up to three additional PCs to VersaLink.**

NOTE: You may connect to any of the four Ethernet jacks on the rear panel as they serve as an Ethernet switch. However, when using the optional uplink port (E1), Ethernet LAN connection is limited to ports E2, E3, and E4.

4. Check to see if the DSL LED is solid green. If the DSL LED is solid green, VersaLink is functioning properly.
5. Check to see if the Ethernet LED is solid green. Solid green indicates that the Ethernet connection is functioning properly.

Congratulations! You have completed the Ethernet hardware installation. No software installation is required when using only an Ethernet connection. Proceed to section 7 to configure VersaLink for Internet connection.

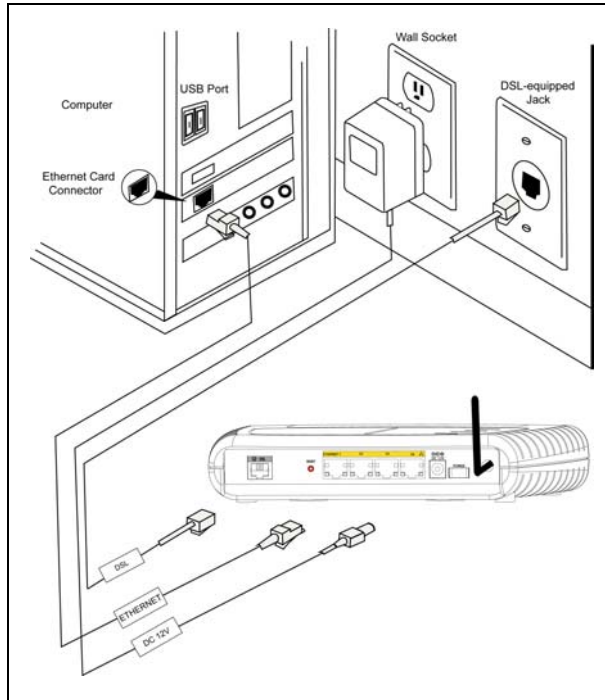

Figure 1. Connection via 10/100 Base-T Ethernet

6.4.2 Connecting PCs via Wireless

IMPORTANT: If you are connecting to VersaLink via a wireless network adapter, the SSID must be the same for both VersaLink and your PC's wireless network adapter. The default SSID for VersaLink is the serial number of the unit (located below the bar code on the bottom of the unit and also on the Westell shipping carton). Locate and run the utility software provided with your PC's Wireless network adapter and enter the SSID value. The PC's wireless network adapter must be configured with the SSID (in order to communicate with VersaLink) before you begin the account setup and configuration procedures. Later, for privacy you can change the SSID by following the procedures outlined in section 12.4 (Wireless Configuration).

NOTE: Client PCs can use any Wireless Fidelity (Wi-Fi) 802.11b/g certified card to communicate with VersaLink. The Wireless card and VersaLink must use the same Wired Equivalent Privacy (WEP) security code type. The factory default for WEP is DISABLED. If you enable WEP, you must ensure the network setting for your wireless adapter is set to "Must Use Shared Key for WEP" or "Open Wi-Fi." You must ensure that your PC's Wi-Fi adapter is configured properly for whichever network setting you use. You can access the settings in the advanced properties of the wireless network adapter.

To network VersaLink to additional computers in your home or office using a wireless installation, you will need to confirm the following:

1. Ensure that an 802.11b/g/g+ wireless network adapter has been installed in each PC on your wireless network.
2. Install the appropriate drivers for your Wireless IEEE802.11b or IEEE802.11g adapter.
3. Make sure the SMA antenna connector is loose. Orient the antenna in the proper configuration. Then, tighten the antenna knob to lock it into place.
4. Connect the power supply cord to the power connector marked **DC 12V** on the rear panel of VersaLink. Plug the other end of the power supply into a wall socket, and then turn on the modem.

5. Connect the DSL phone cable from the connector marked  on the rear panel of VersaLink to the DSL-equipped telephone line jack on the wall. **IMPORTANT:** Do not use a DSL filter on this connection. You must use the phone cord that was provided with the VersaLink kit.
6. Check to see if the DSL LED is solid Green. If the DSL LED is solid Green, VersaLink is functioning properly.
7. Check to see if VersaLink's Wireless LED is solid Green. This means that the Wireless interface is functioning properly.

Congratulations! You have completed the Wireless installation VersaLink. You must now go to section 7 to configure VersaLink for Internet connection.

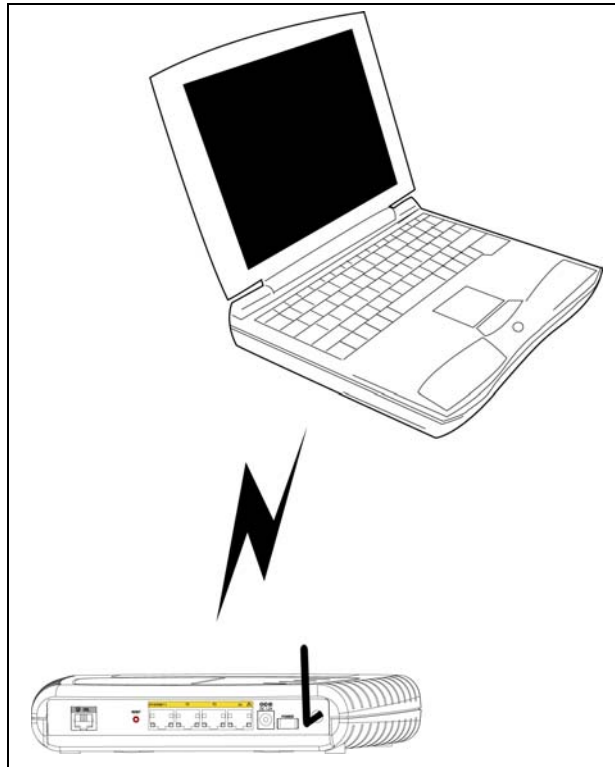



Figure 2. Connection via Wireless

6.4.3 Installation via Ethernet and Wireless Combination

The VersaLink™ supports simultaneous use of 10/100 Base-T Ethernet and Wireless configurations. The following instructions explain how to install VersaLink for simultaneous use of Ethernet and Wireless ports.

NOTE: Refer to Figure 1 and Figure 2 for instructions on hardware installation via Ethernet and Wireless connections.

1. Ensure that an 802.11b/g/g+ wireless network adapter has been installed in each PC on your wireless network
2. Install the appropriate drivers for your Wireless IEEE802.11b or IEEE802.11g adapter.
3. Make sure the SMA antenna connector is loose. Orient the antenna in the proper configuration. Then, tighten the antenna knob to lock it into place.
4. Connect the power supply cord to the power connector marked **DC 12V** on the rear panel of VersaLink. Plug the other end of the power supply into a wall socket, and then turn on the modem.
5. Connect the DSL phone cable from connector marked  on the rear panel of VersaLink to the DSL-equipped telephone line jack on the wall. **IMPORTANT: Do not** use a DSL filter on this connection. You must use the phone cord that was provided with the kit.
6. Connect the yellow Ethernet cable from any one of the Ethernet jacks marked  on the rear panel of VersaLink to the Ethernet port on your computer. **Repeat this step to connect up to three additional PCs to VersaLink.**

NOTE: You may connect to any of the four Ethernet jacks on the rear panel as they serve as an Ethernet switch. However, when using the optional uplink port (E1), Ethernet LAN connection is limited to ports E2, E3, and E4.

7. Check to see if the DSL LED is solid green. If the DSL LED is solid green, VersaLink is functioning properly.
8. Check to see if the Ethernet LED is solid green. Solid green indicates that the Ethernet connection is functioning properly.
9. Check to see if VersaLink's Wireless LED is solid green. This means that the Wireless interface is functioning properly.

Congratulations! You have completed the simultaneous hardware (Ethernet and Wireless) installation. You must now go to section 7 to configure VersaLink for Internet connection.

7. CONFIGURING VERSALINK FOR INTERNET CONNECTION

To browse the Internet using VersaLink™, you must set up your account profile, confirm your DSL sync, and establish a PPP session with your Internet Service Provider (ISP). Refer to the Internet service provider's installation manual to install the software required for your Internet connection.

NOTE: Internet service provider subscriber software and connection requirements may vary. Consult your Internet service provider for installation instructions.

7.1 Setting Up an Account Profile

After connecting VersaLink, bring up your Web browser and type either **http://dslrouter** or **http://192.168.1.1** in the browser's address window, and then press 'Enter' on your keyboard. The **Getting Started** screen will appear. Click on **next**.

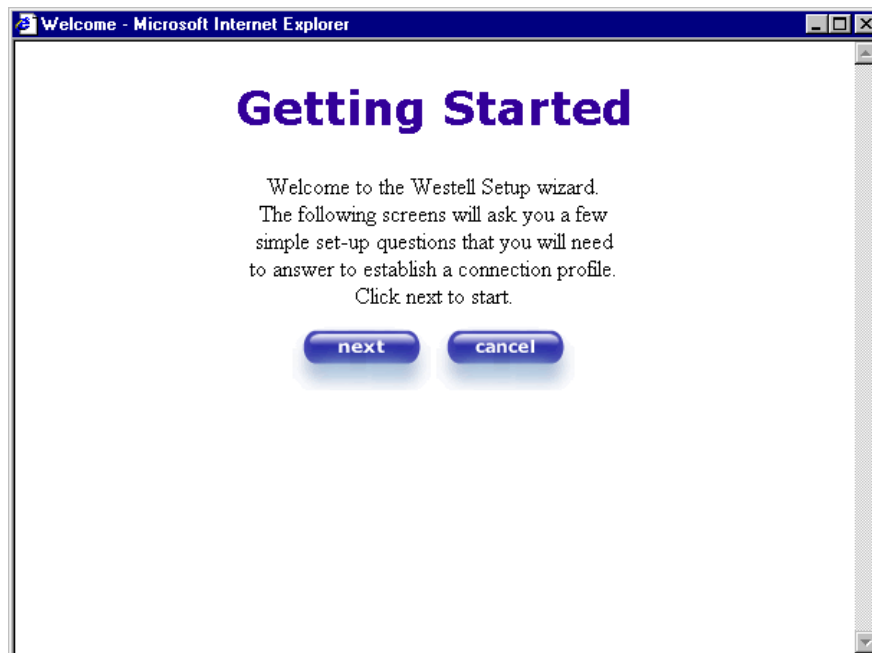

If you clicked **Next**, the following screen will be displayed. This screen will allow you to set up your account profile.

NOTE: Before you set up your account profile, you must obtain your **Account ID**, **Account Password**, and **VPI/VCI** values from your Internet service provider. You will use this information when you set up your account parameters. If you are at a screen and need help, click on the **Help** button to learn more about the screen.

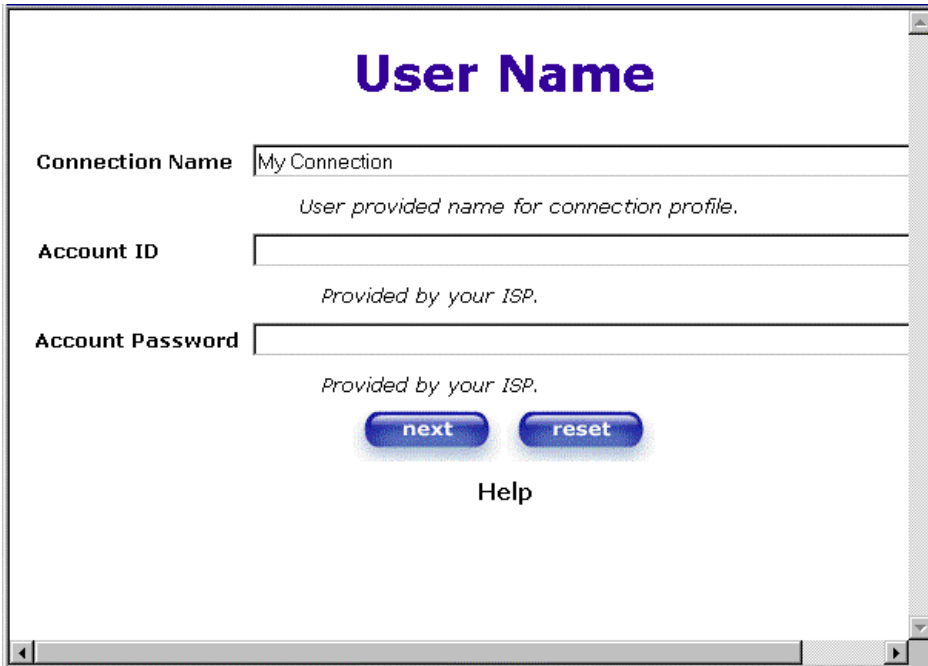

User Name

Connection Name
User provided name for connection profile.

Account ID
Provided by your ISP.

Account Password
Provided by your ISP.

Help

Type in your account parameters. (Account parameters are required before connecting to the Internet.)
Account Parameters include:

- **Connection Name**-the Connection Name is a word or phrase that you use to identify your account. (You may enter up to 64 characters in this field.)
- **Account ID**-the Account ID is provided by your Internet Service Provider. (You may enter up to 255 characters in this field.)
- **Account Password**-the Account Password is provided by your Internet Service Provider. (You may enter up to 255 characters in this field.)

After you type your account parameters at the **User Name** screen, they will be displayed as shown in the screen below. Click **next** if you want your account parameters to take effect. Click on **reset** if you do not want the account parameters to take effect or if you want to retype the parameters.

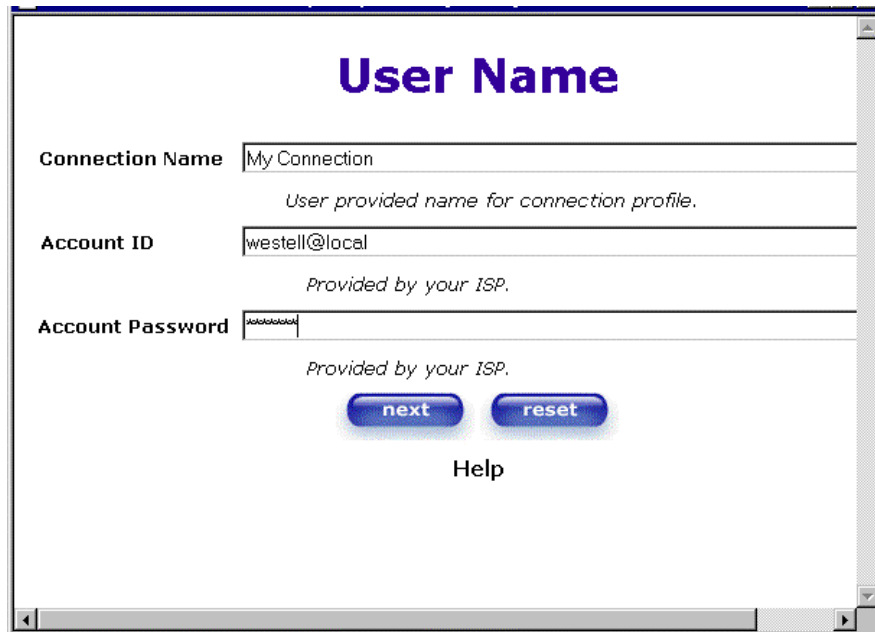

User Name

Connection Name
User provided name for connection profile.

Account ID
Provided by your ISP.

Account Password
Provided by your ISP.

[Help](#)

Type the VPI and VCI values (**0** for VPI and **35** for VCI default) you obtained from your Internet service provider. The actual VPI/VCI values may vary according to your ISP. Click on **next**.

NOTE: Depending on your Internet Service Provider, the VPI/VCI screen may come pre-configured and it will be displayed here. In this case, you should not change any values in this screen. Click on **next** to go to the **PROTOCOL** screen.

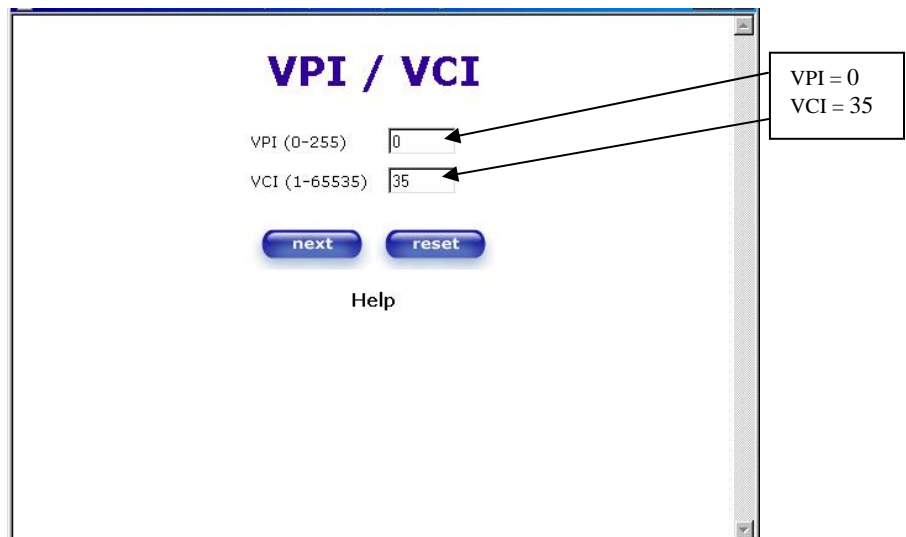

VPI / VCI

VPI (0-255)

VCI (1-65535)

[Help](#)

VPI = 0
VCI = 35

Select the Protocol type that you obtained from your Internet service provider. Click on **next**.

NOTE: Depending on your Internet Service Provider, the **PROTOCOL** screen may come pre-configured and it will be displayed here. In this case, you will need to click on **next** to go to the **SET-UP COMPLETE** screen.



When the **SET-UP COMPLETE** screen appears, you have successfully completed your Account Profile setup. Click **done**.

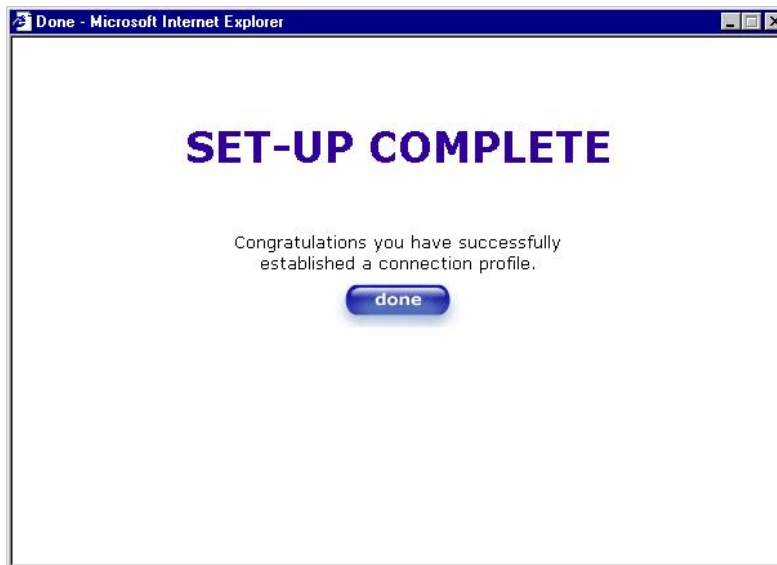

If you changed the **VPI/VCI** settings and clicked **done** in the **SET-UP COMPLETE** screen, the following pop-up screen will appear. Click **OK**.

NOTE: The following pop-up will appear only if you have changed the **VPI, VCI, or Protocol** values in the preceding screens. If you did not change any of these values, this pop-up screen will not appear and the Gateway will not be reset. If your Gateway's connection setting is set to "Always On" and you have changes any of these values, the Gateway will reset automatically. For instructions on editing your connection settings, see section 10.2.

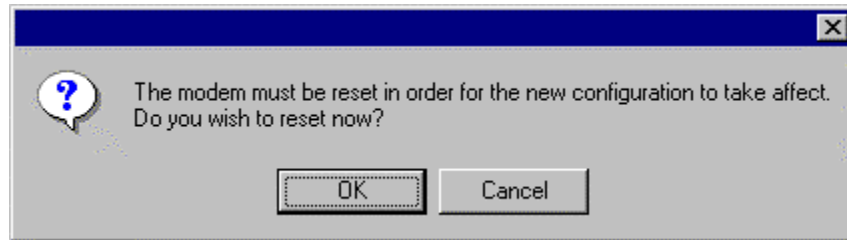

If you clicked **OK** in the pop-up, the following screen will be displayed. VersaLink™ will be reset and the new configuration will take effect. Next, proceed to section 7.2 to confirm your DSL sync.

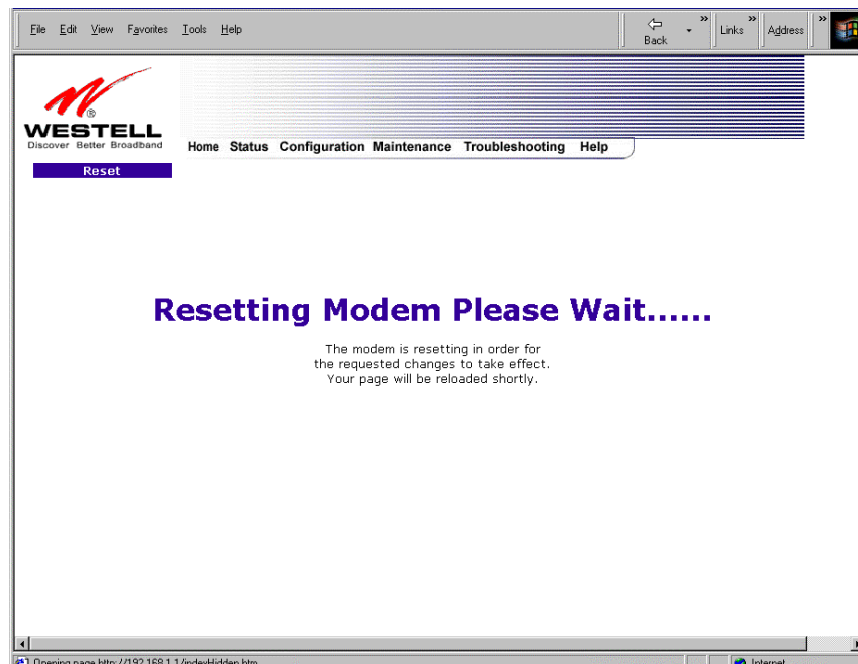

7.2 Confirming a DSL Sync

Remember, you must have active DSL service before VersaLink can synchronize with your ISP's equipment. To determine if VersaLink has a DSL sync, view the DSL Connection Rate in the **Connection Overview** section (see the following Home page). If the status reads **No DSL Connection**, check the DSL physical connection, explained in section 6 (INSTALLING THE HARDWARE) of this User Guide.

NOTE: If no DSL sync is established, the **connection** button will not be displayed in the following screen. To determine if the DSL sync is established, check VersaLink's DSL LED. If the DSL LED is not solid green, you do not have a DSL sync established. Contact your ISP for further instructions.

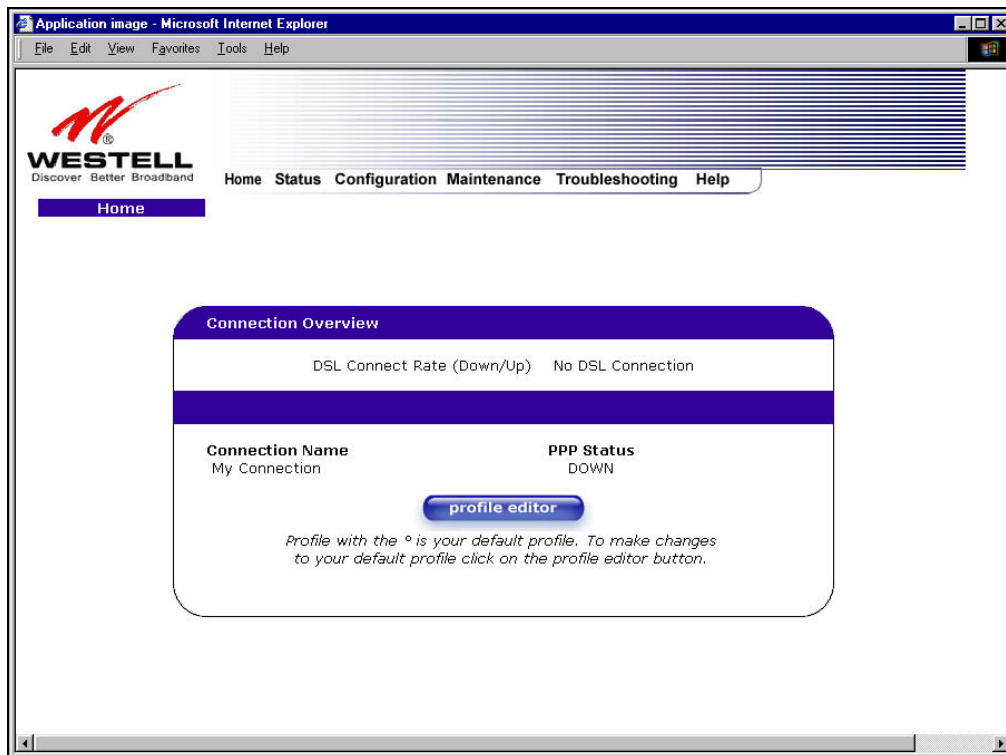

The following screen shows the DSL connection rate with values that indicate a successful DSL SYNC has been established. The connection rate values represent the transmission speed of your DSL line. (The Gateway may take time to report these values.) Click on the **Connect** button to establish a PPP session.

NOTE: VersaLink will handle transmission rates up to 8 Mbps. Your actual DSL rates may vary depending on your Internet service provider.

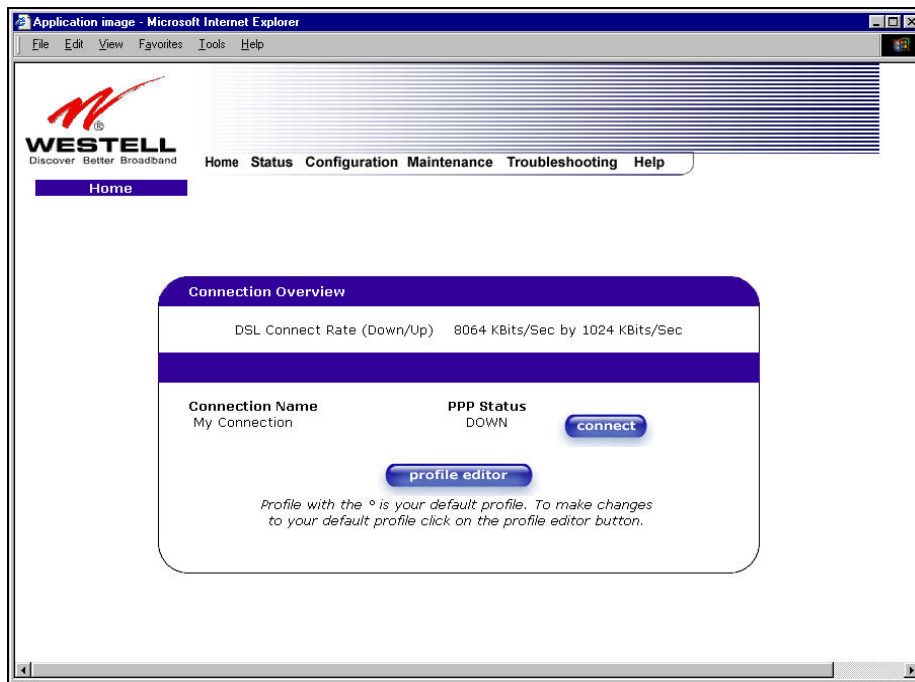

7.3 Establishing a PPP Session

View the **PPP Status** at the Home page. If the PPP Status displays **DOWN**, click the **Connect** button to establish a PPP session.

NOTE: Whenever the PPP Status displays **DOWN**, you do not have a PPP session established. If your Gateway's connection setting is set to "Always On" or "On Demand," after a brief delay, the PPP session will be established automatically and the PPP Status will display **UP**. If the connection setting is set to "Manual," you must click on the **Connect** button to establish a PPP session. Once the PPP session has been established (PPP Status displays **UP**), you may proceed with your Gateway's configuration. Section 10.2 provides instructions on editing the connection settings. (Refer to the 'Edit My Connection' screen.) VersaLink's factory default connection setting is "Manual."

If you click the **Connect** button, the following screen will appear briefly. The **PPP Status** in the **Connection Overview** window allows you to view the state of your ISP connection. When the **PPP Status** displays **Connecting...**, this means that you are establishing a PPP session.

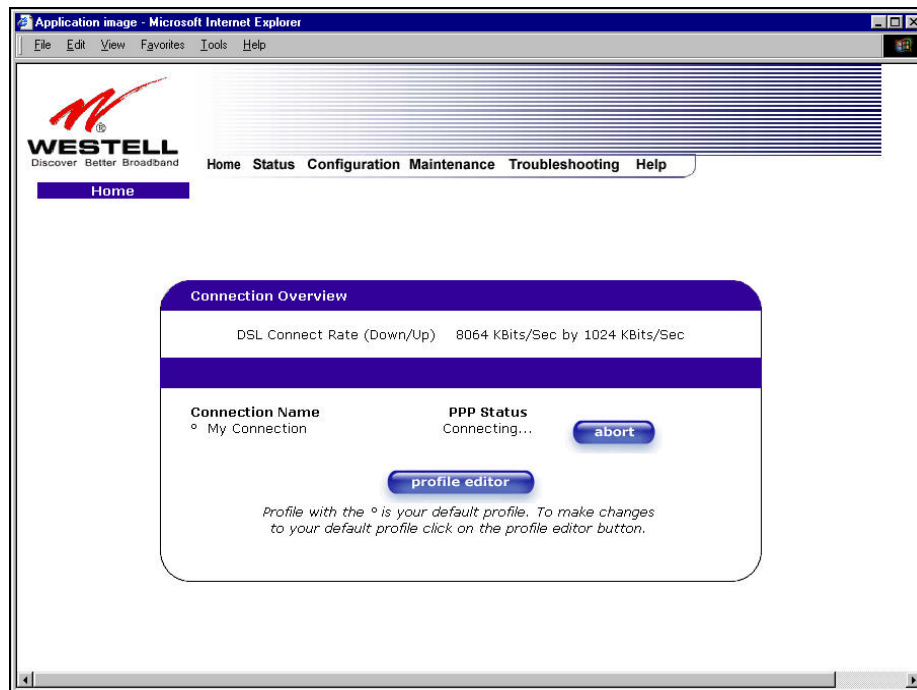

After a PPP session has been established, the **PPP Status** will display **UP**. Congratulations! You may now browse the Internet.

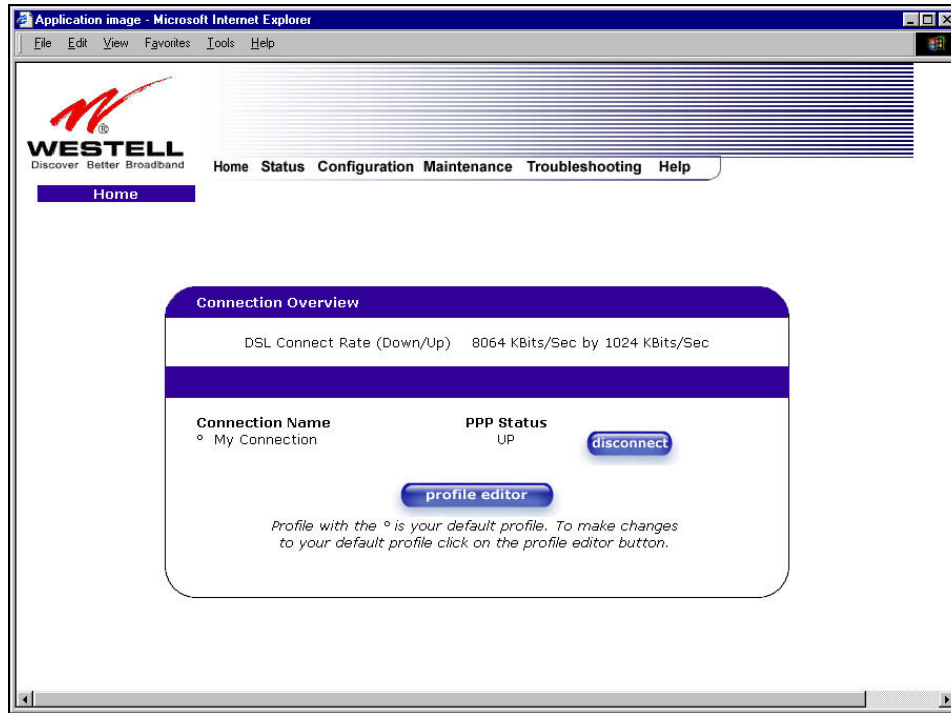

For example, if you want to visit Westell's home page, type **http://www.westell.com** in your browser's address window.

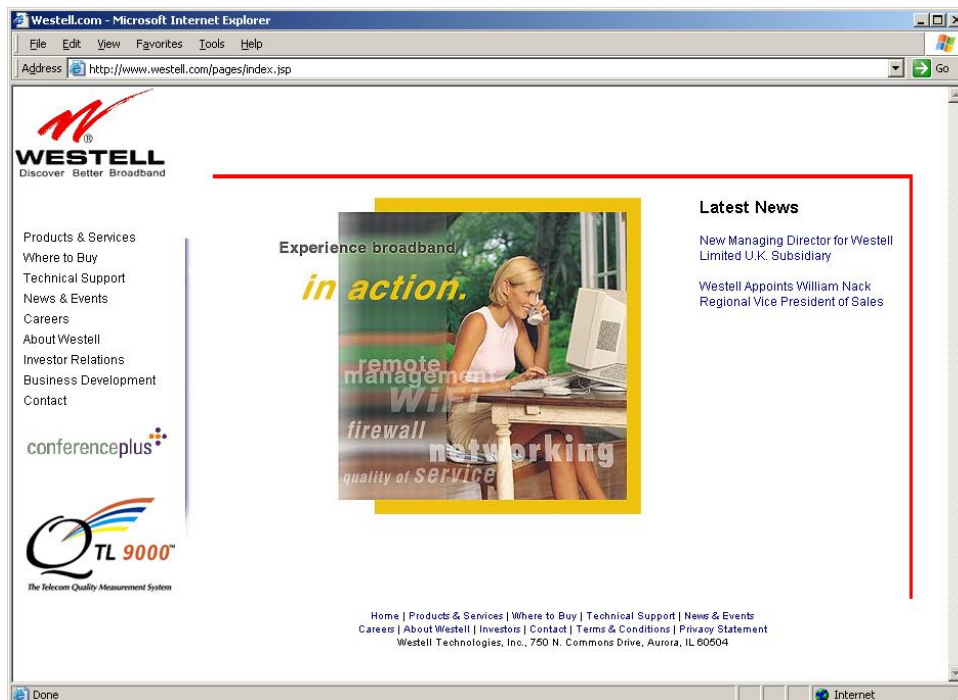

7.4 Disconnecting a PPP Session

If you have finished browsing the Internet and want to disconnect from your Internet service provider, click on the **Disconnect** button in the **Connection Overview** screen (the preceding screen). The following pop-up screen will appear. Click on **OK** to disconnect the PPP session.

CAUTION: If you disconnect the PPP session, this will disconnect the Gateway from the Internet, and all users will be disconnected until the PPP session is re-established.

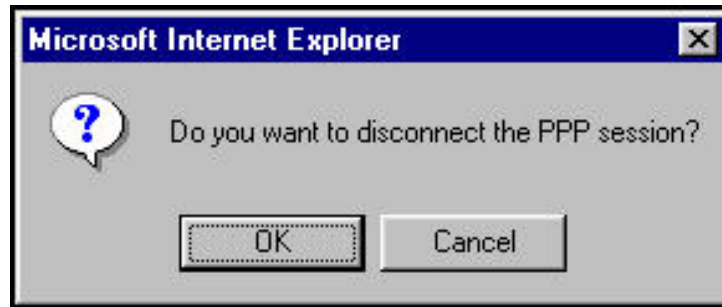

If you clicked the **Disconnect** button in the preceding **Connection Overview** screen, the **PPP Status** should display **DOWN**. This means that you no longer have a PPP session (no IP connection to your Internet service provider). However, your DSL session will not be affected. When you are ready to end your DSL session, simply power down VersaLink via the power switch on VersaLink's rear panel.

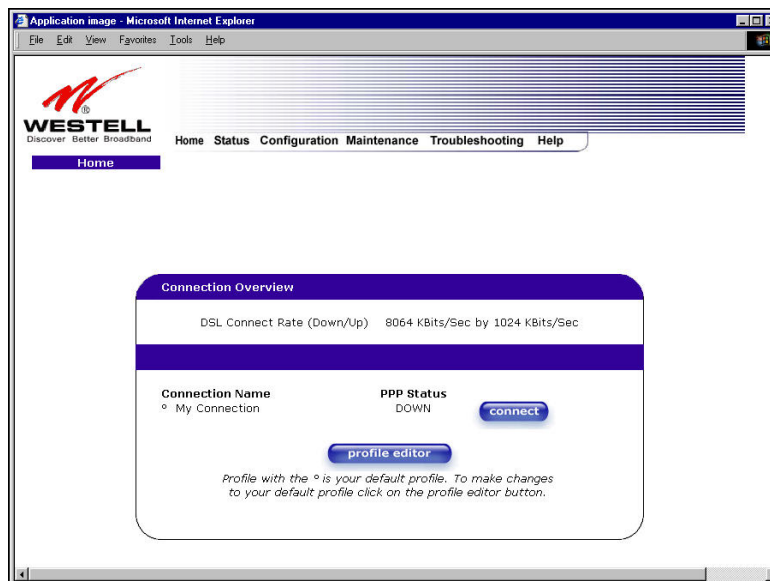

When you are ready to establish a PPP session, click on the **connect** button. (If you powered down VersaLink, you must first power up VersaLink and log on to your account profile before you establish a PPP session.)

NOTE: When you are ready to exit VersaLink's interface, click on the **X** (close) in the upper-right corner of the window. Closing the window will not affect your PPP Status (your PPP session will not be disconnected). You must click on the **disconnect** button to disconnect your PPP session. When you are ready to restore this interface, you must launch your Internet browser and type **http://dslrouter/** or type **http://192.168.1.1/** in the browser's address window and press 'Enter' on your keyboard.

8. SETTING UP MACINTOSH OS X

This section provides instructions on how to use Macintosh Operating System 10 with VersaLink. Follow the instructions in this section to create a new network configuration for Macintosh OS X.



NOTE: Macintosh computers must use VersaLink's Ethernet installation. Refer to section 6, (INSTALLING THE HARDWARE).

Open the System Preference Screen

After you have connected the Westell VersaLink to the Ethernet port of your Macintosh, the screen below will appear. Click on the “Apple” icon in the upper-right corner of the screen and select **System Preferences**.

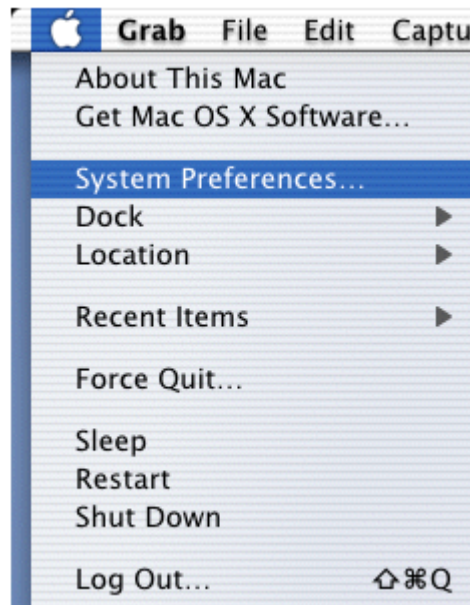

Choose the Network Preferences

After selecting **System Preferences...**, from the previous screen, the **System Preferences** screen will be displayed. From the **System Preferences** screen, click on the **Network** icon.

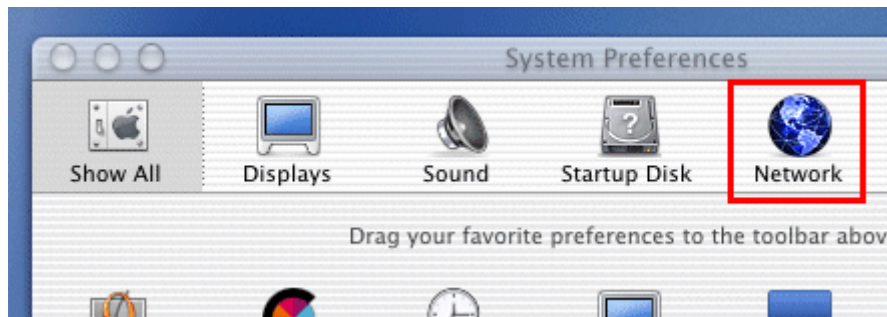

Create a New Location

After selecting the **Network** icon at the **System Preferences** screen, the **Network** screen will be displayed. Select **New Location** from the **Location** field.

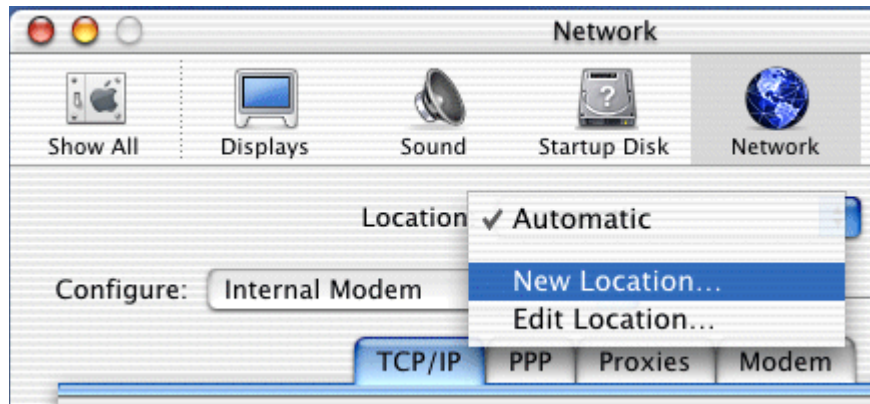

Name the New Location

After selecting **New Location** from the **Network** screen, the following screen will be displayed. In the field labeled **Name your new location:**, change the text from “Untitled” to “Westell.” Click **OK**.



Select the Ethernet Configuration

After clicking on **OK** in the preceding screen, the **Network** screen will be displayed. The **Network** screen shows the settings for the newly created location. From the **Configure** field in the **Network** screen, select **Built-in Ethernet**. Click on **Save**.

NOTE: Default settings for the Built-in Ethernet configuration are sufficient to operate VersaLink.

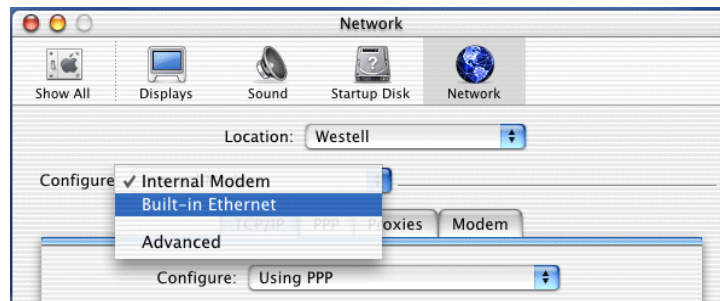

Check the IP Connection

To verify that the computer is communicating with VersaLink, follow the instructions below.

1. Go to the “**Apple**” icon in the upper-right corner of the screen and select **System Preferences**.
2. From the **System Preferences** screen, click on the **Network** icon. The **Network** screen will be displayed.
3. From the **Configure** field in the **Network** screen, select **Built-in Ethernet**.
4. View the IP address field. An IP address that begins with **192.168.1** should be displayed.

NOTE: The DHCP server provides this IP address. If this IP address is not displayed, check VersaLink’s wiring connection to the PC. If necessary, refer to section 5 for hardware installation instructions.

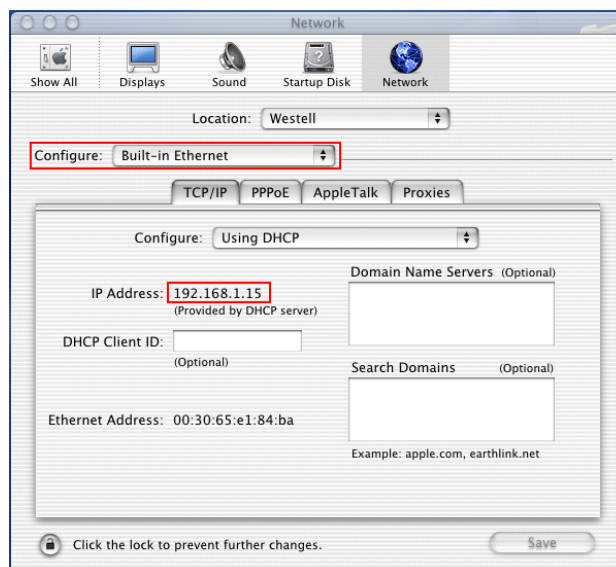

Create a User Account

In the address window of your Internet Explorer web browser, type **http://dslrouter/**. Press 'Enter' on your keyboard.

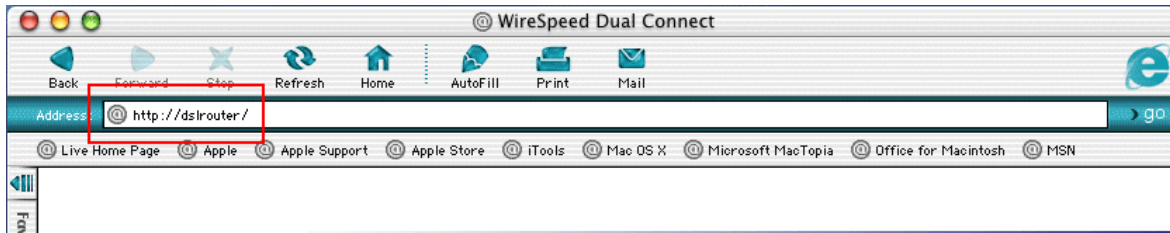

The **Getting Started** screen will be displayed. You may now begin your Account Setup. Refer to section 7 of this User Guide to configure your Westell VersaLink for Internet connection.

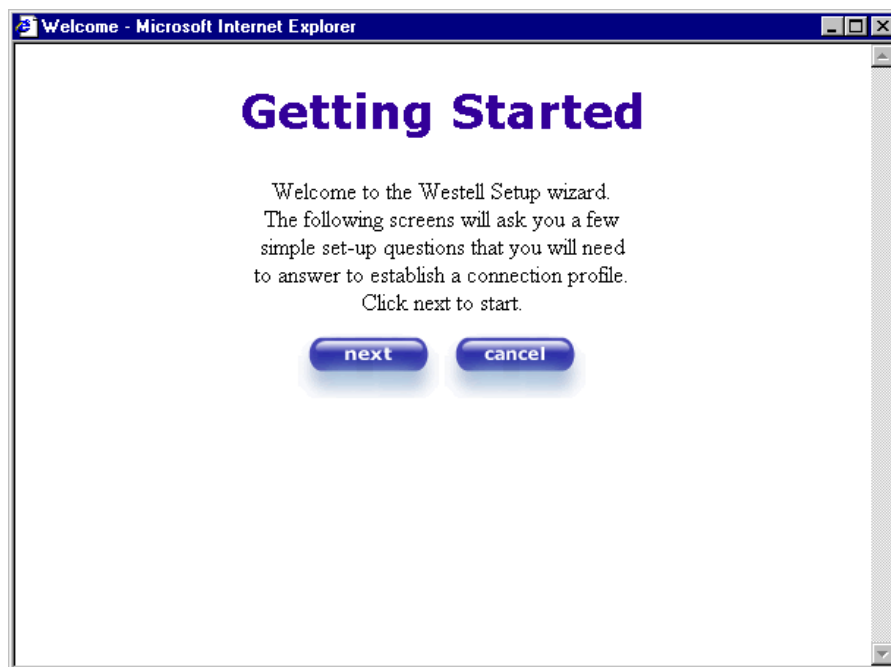



The following sections explain the advanced features of VersaLink™.

[This Page Intentionally Left Blank]

9. SETTING UP ADVANCED CONFIGURATION

Advanced Configuration instructions are explained in Section 10 through Section 16. If you want to set up advanced features for VersaLink, follow the instructions provided in sections 10 through.

IMPORTANT: The following sections assume that you have active DSL and Internet service.

VersaLink™ allows you to make changes to advanced features of your Gateway such as account profiles, routing configurations, and firewall settings. The following sections explain each feature and show you how to make changes to VersaLink's settings. A menu is displayed at the top of each screen and will allow you to navigate you to the various configuration options of your VersaLink Gateway. If you are at a screen and need help, click on the **Help** button to learn more about that screen.

Please note that the menu options displayed will vary according to the WAN configuration you have chosen to use, DSLATM PORT or ETHERNET PORT1. However, all menu options are displayed when VersaLink is enabled for DSLATM PORT. Instructions on enabling and disabling DSLATM PORT and ETHERNET PORT 1 are explained in section 12.6, Advanced WAN. This document was created with the VersaLink DSLATM PORT enabled. The sections explained throughout this document will indicate when a menu item is unavailable.

10. HOME

As you navigate through the various screens of VersaLink, the name of the active page that you have selected will appear in the upper-left corner of the screen, as shown below. Please note that the actual values may differ from the values displayed in the screens.

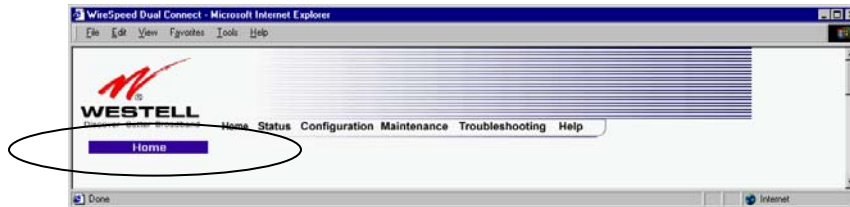

If you have set up your account profile and established your PPP session as discussed in section 7, the following settings will be displayed when you click on your **Home** page. Click on **profile editor** to edit your connection profile.

NOTE: If you have created multiple account profiles, select the option button for the active account profile.

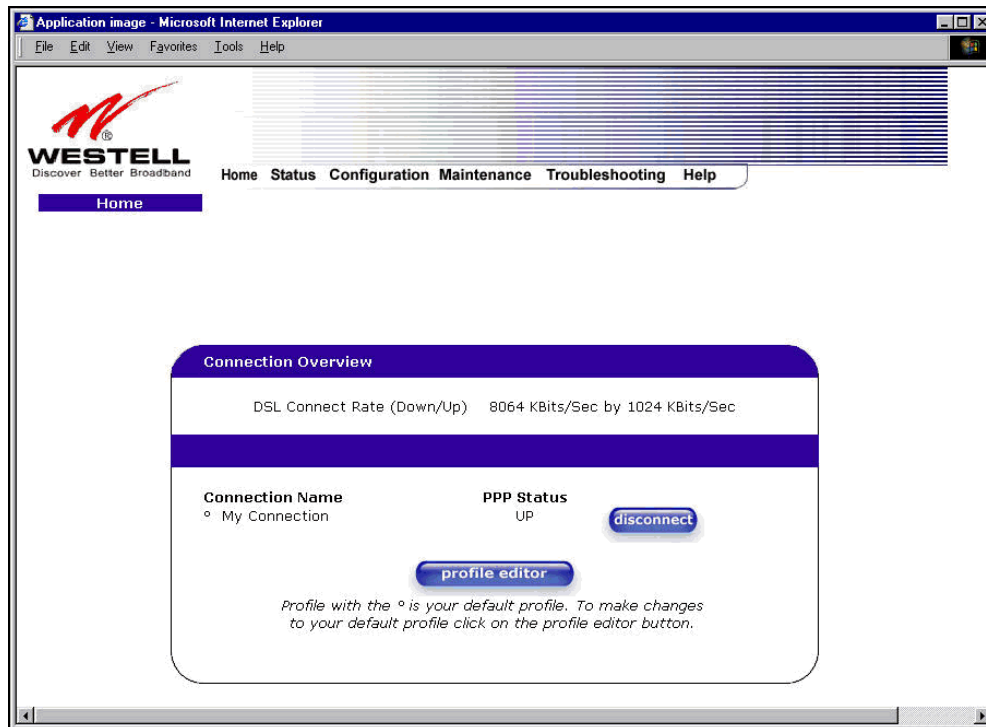

Connection Overview	Displays your DSL connection rate.
Connection Name	This Connection Name is from the connection profile that you established in section 8.
PPP Status	UP = PPP session established DOWN = No PPP session established.
Connect/Disconnect	CONNECT = Establish a PPP session DISCONNECT = Disconnect a PPP session
Profile Editor	This allows you to make changes to the profile that you created in section 8.

10.1 Adding Account Profiles

If you select the **Profile Editor** button from your **Home** page, the **Advanced Home** screen will appear, as shown below. Click on the **new connection** button in the **Advanced Home** screen. The **New Connection** screen will appear. Enter your account profile information and click on **New**. Next, click on **OK** in the pop-up screen to save your new connection. If you do not want to add a connection profile, click on **Close** in the **New Connection** screen.

NOTE: NAT Profiles allow you to create specific service settings. A NAT Profile may be associated with a certain connection setting, or NAT services. This allows you to customize the profile for specific users. You may store up to eight unique user profiles in your Gateway. Details on the **New Connection** screen are located at the end of this section.

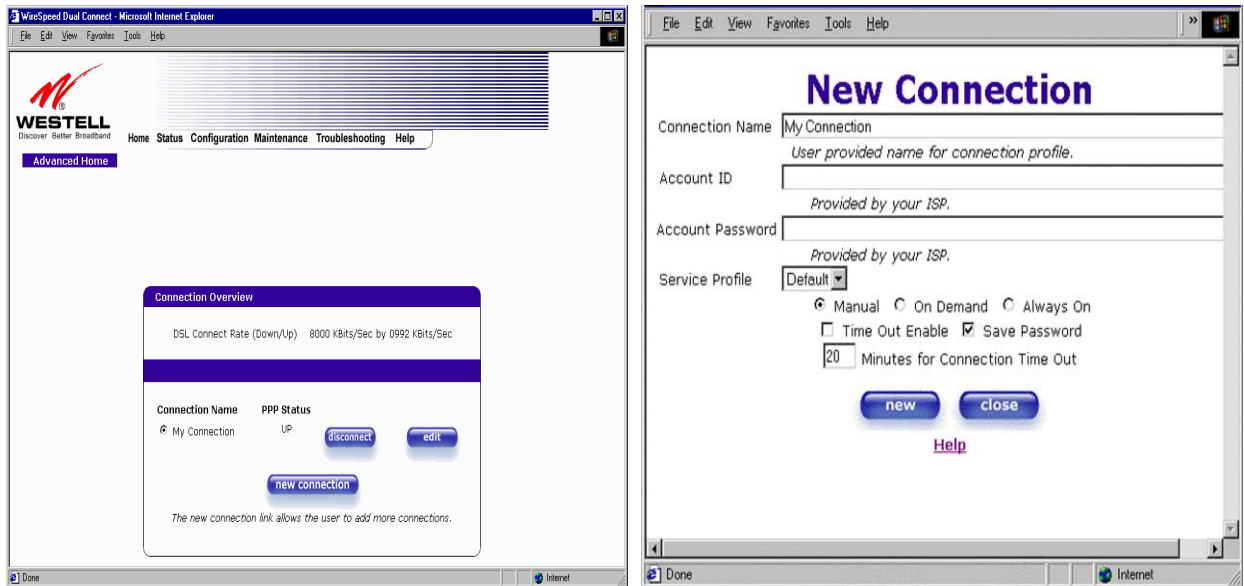

If you clicked **OK** in the “**Save new connection?**” pop-up screen, the following screen will be displayed. This screen will allow you to edit a connection profile. Select a profile name from the **Connection Name** field and click on the **edit** button adjacent to the name.

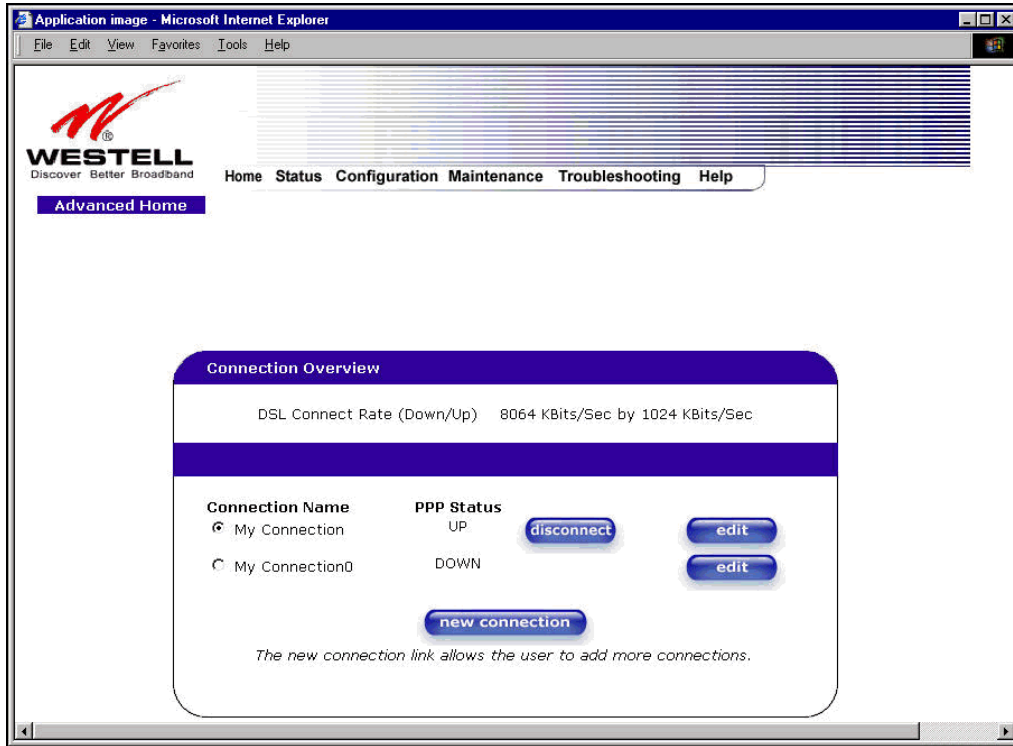

10.2 Editing Account Profiles

If you clicked **Edit** in the preceding screen, the **Edit “My Connection”** screen will appear. Follow the steps in the **Edit “My Connection”** screen to change your existing connection profile, which you set up in section 8. If you do not want to change your connection profile, click on **close** in the screen. Click on **delete** if you want to delete your connection profile.

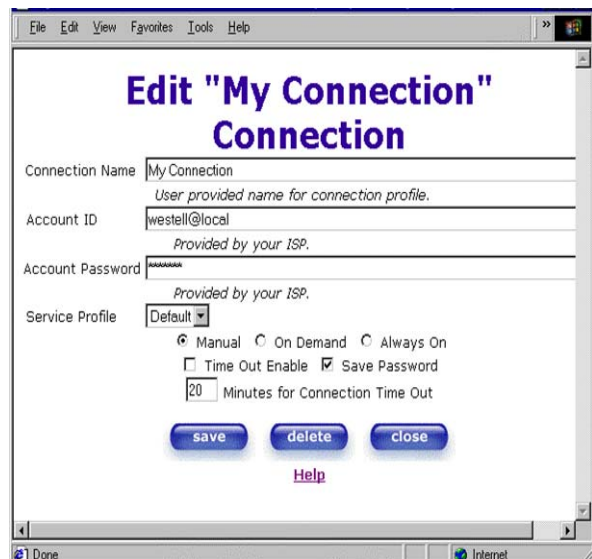
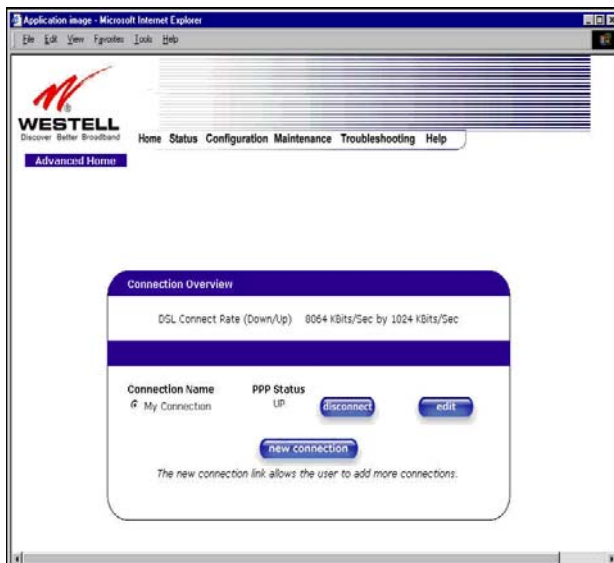



Connection Name	This field allows you to enter a new connection name of your choice (up to 64 characters).
Account ID	The account ID that you used in section 8 if you are connecting to the same Service Provider. If you have multiple Service Providers, you can enter this information at this time.
Account Password	The account password that you used in section 8 if you are connecting to the same Service Provider. If you have multiple Service Providers, you can enter this information at this time.
Service Profile	Westell recommends that you use the Default parameter.
Manual	Factory default = MANUAL Selecting this feature allows you to manually establish your PPP session.
On Demand	Selecting this feature allows the Gateway to automatically re-establish your PPP session on demand anytime your PC requests Internet activity (for example, browsing the Internet, email, etc.). When you have traffic, it may cause a delay.
Always On	Selecting this feature allows the Gateway to automatically establish a PPP session when you log on, or if the PPP session goes down.
Time Out Enable	Factory Default = DISABLED Selecting this feature allows you to enable the timeout parameter of your PPP session, which is set to a factory default of 20 minutes.
Save Password	Selecting this feature allows you to save the password for your new connection profile in VersaLink so that you will not have to re-enter it in case of a re-boot.
Minutes for Connection Time Out	This option allows you to specify the number of minutes that you want a PPP session to stay active before it is disconnected due to inactivity. (This feature works if you have selected the Time Out Enable feature explained above.)

11. STATUS

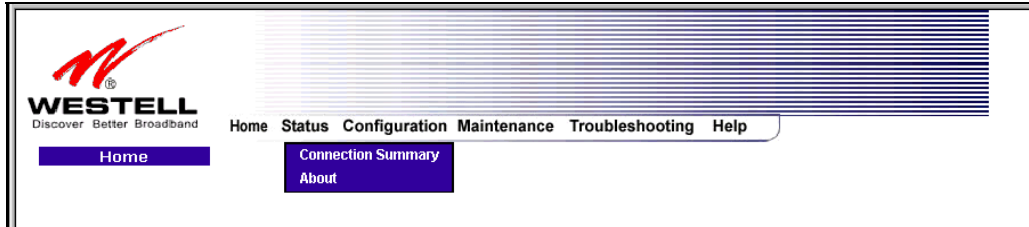

11.1 Connection Summary

The following settings will be displayed if you select **Connection Summary** from the **Status** menu.

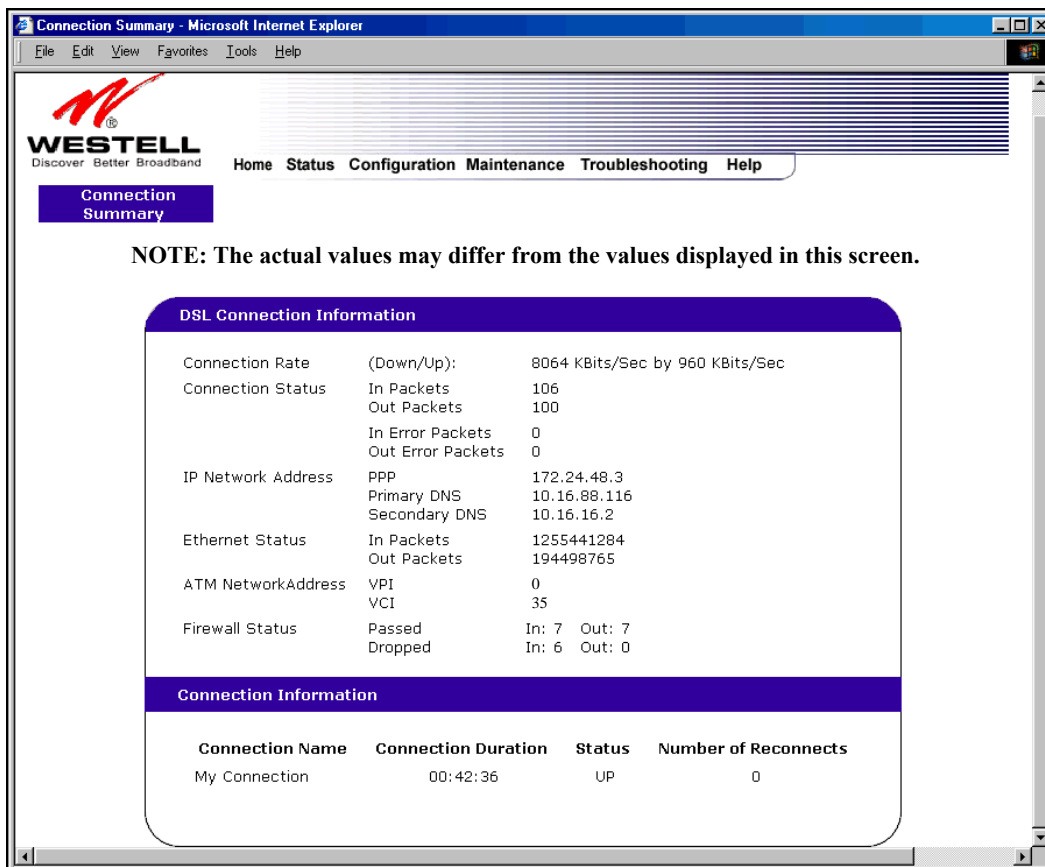

DSL Connection Information	
Connection Rate	This field will let you know if you have a DSL signal and the DSL rate at which you are connected.
Connection Status	This field will show how much information was received (IN) or sent (OUT) in packets.
IP Network Address	PPP = An IP address identifies your device on the Internet Primary DNS = Provided by your Service Provider Secondary DNS = Provided by your Service Provider

Ethernet Status	This field will display your Ethernet information that was received (IN) or sent (OUT) in packets on your Ethernet port.
ATM Network Address	This field will display your VPI and VCI values, which are provided by your ISP.
Firewall Status	This field will display your firewall traffic in packets. Passed: Monitors information traffic that was successfully received (IN) or transmitted (OUT) in packets. Dropped: Monitors information traffic that was not successfully received (IN) or transmitted (OUT) due to your firewall settings.
PPP Connection Information	
Connection Name	This is from the connection profile that you established in section 8.
Connection Duration	This field will display how long your PPP session has been connected.
Status	This field will display the status of your PPP session. UP=Connected DOWN=Disconnected
Number of Reconnects	This field will display the number of attempts that were made to establish a PPP session.

11.2 About

The following settings will be displayed if you select **About** from the **Status** menu.

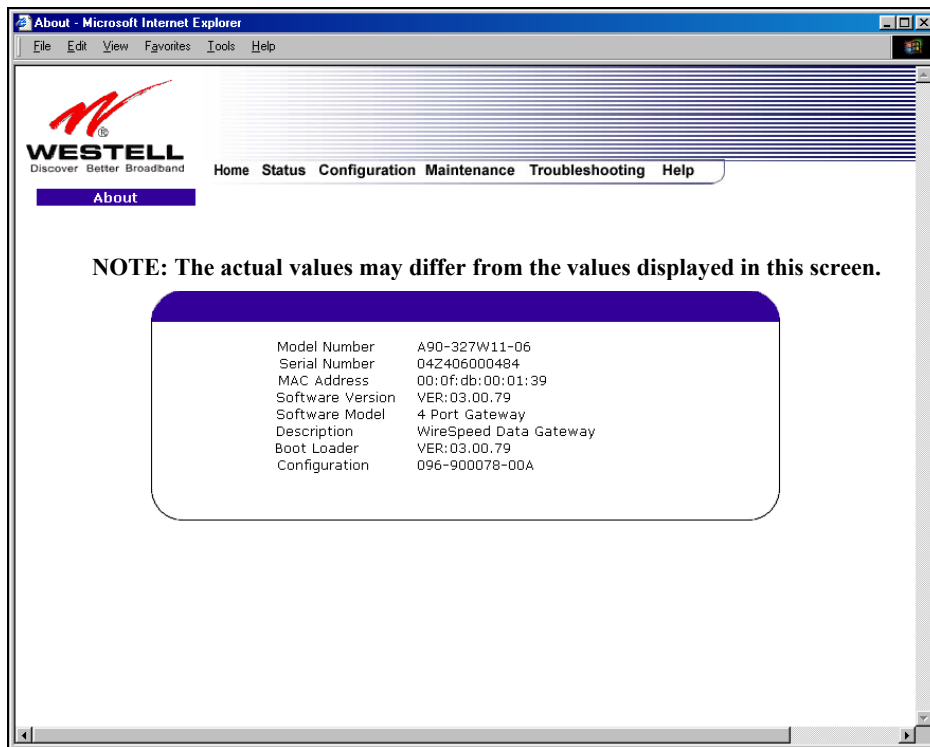

Model Number	VersaLink manufacturer's model number.
Serial Number	VersaLink manufacturer's serial number.
MAC Address	Media Access Controller (MAC) i.e., hardware address of this device.
Software Version	Version of Application Software.
Software Model	VersaLink application type.
Description	Product description.
Boot Loader	Version of boot loader software
Configuration	Proprietary configuration number of this device.

12. CONFIGURATION

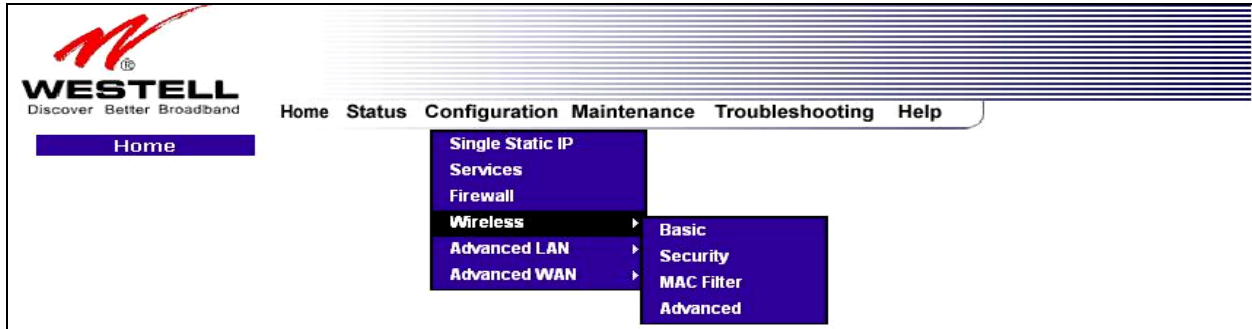

12.1 Single Static IP – Single IP Address PassThrough

The following settings will be displayed if you select **Single Static IP** from the **Configuration** menu. The Single Static IP Configuration screen allows you to select the device on your LAN that will share your Single Static IP. Before you begin this section, configure your PC settings to obtain an IP address from your Gateway automatically. (Refer to your Windows Help screen for instructions.)

NOTE: Single Static IP (SSI) allows the user to share the WAN assigned IP address with one device on the LAN. By doing this, the device with the SSI becomes visible on the Internet. Network Address Translation (NAT) and Firewall rules do not apply to the device configured for SSI. If you are using Bridge (Routed Bridge) protocol, **Single Static IP** configuration will not be available.

IMPORTANT: Static NAT must be disabled before you can enable **Single Static IP**. To disable Static NAT, select **Services** from the **Configuration** menu. Next, click on the **static NAT** button. Select the device from the **Static NAT Device** drop-down menu and click on **disable**. Return to Single Static IP Configuration by selecting **Single Static IP Configuration** from the **Configuration** menu.



12.1.1 Enabling Single Static IP – Single IP Address PassThrough (Applicable for PPPoE Connections Only)

To enable Single Static IP, select a device that will share your Single Static IP from the options listed in the window. Click on **enable**.

NOTE: The Single Static IP Configuration screen allows you to select the device on your LAN that will share your Single Static IP.

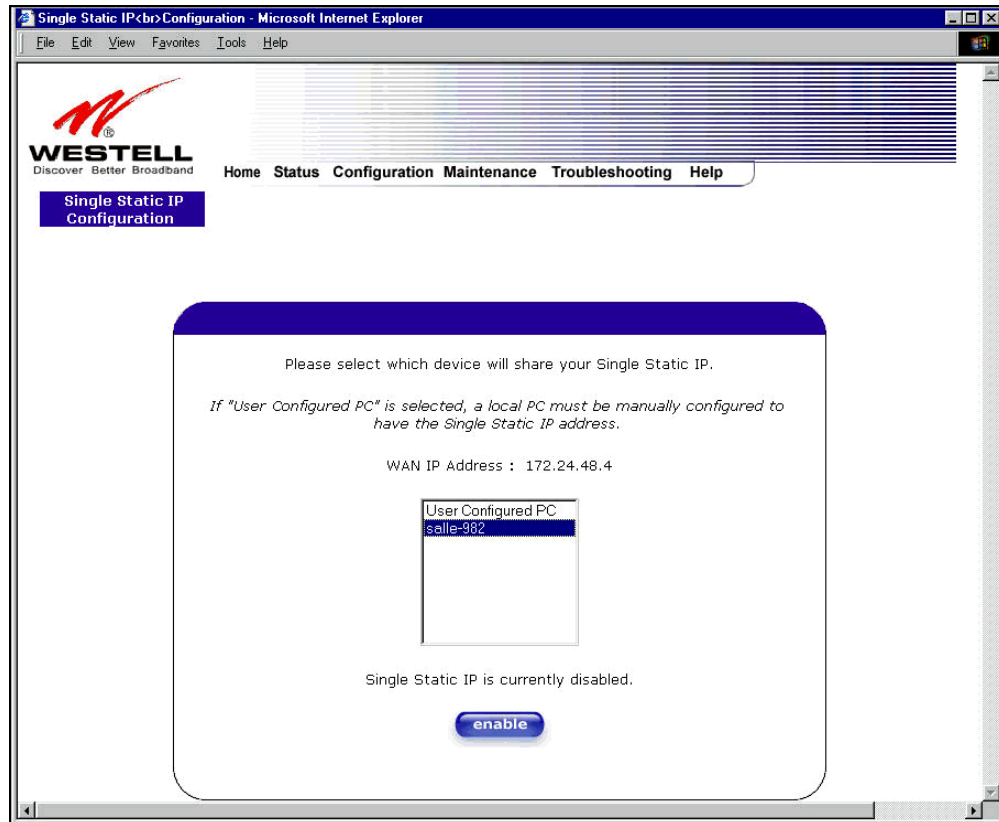

If you select a device and clicked on **enable**, the following pop-up screen will appear. Click on **OK** to enable this device for Single Static IP. Click on **Cancel** if you do not want to enable Single Static IP.

NOTE: The actual device name may differ from the name displayed in this screen.

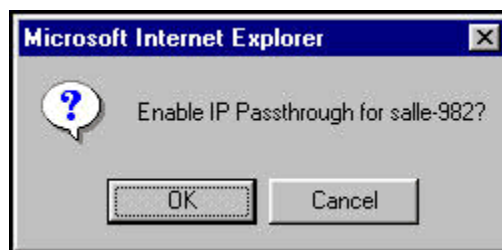

If you clicked **OK** in the preceding pop-up screen, the following pop-up screen will appear. VersaLink must be reset to allow the new configuration to take effect. Click on **OK**.

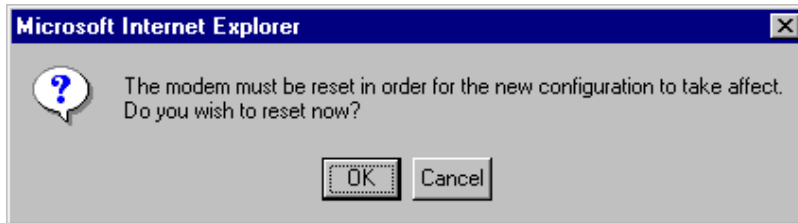

If you clicked **OK** in the preceding screen, the following screen will be displayed. VersaLink will be reset and the new configuration will take effect.

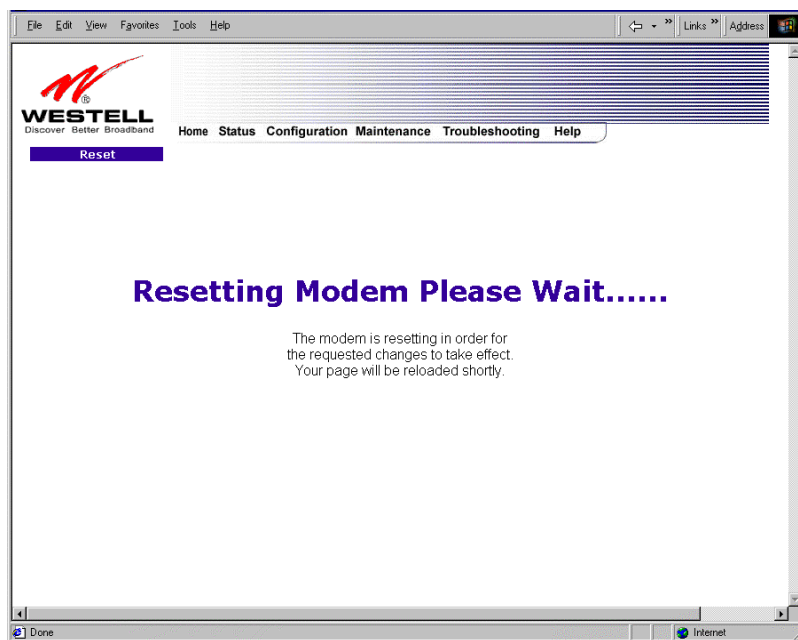

After a brief delay, the home page will be displayed. Confirm that you have a DSL sync and that your PPP session displays **UP**. (Click on the **connect** button to establish a PPP session). Next, Select **Single Static IP** from the **Configuration** menu to confirm that Single Static IP is **enabled**, as shown in the following screen.



IMPORTANT: After you enable Single Static IP, you must reboot your computer.

NOTE: If you chose to enable **User Configured PC**, wait for the Gateway to reset and then manually enter the WAN IP, Gateway, and Subnet mask addresses you obtained from your Internet service provider into a PC.

12.1.2 Disabling Single Static IP – Single IP Address PassThrough

To disable Single Static IP, select **Single Static IP** from the **Configuration** menu. Click on **disable**.

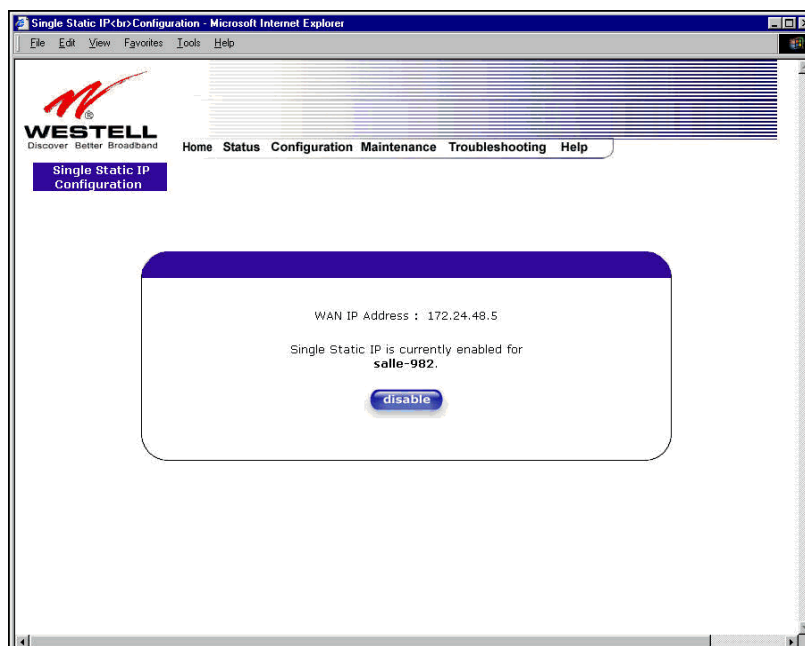

If you clicked **disable** in the preceding screen, the following pop-up screen will be displayed. Click on **OK**.



If you clicked **OK** in the **Disable IP Passthrough?** screen, the following pop-up screen will be displayed. This screen will allow the modem to be reset and the new configuration will take effect. Click on **OK**.

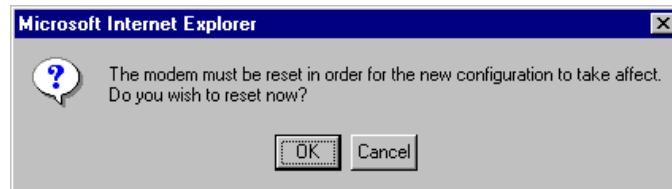

If you clicked **OK** in the preceding screen, the following screen will be displayed. VersaLink will be reset and the new configuration will take effect.

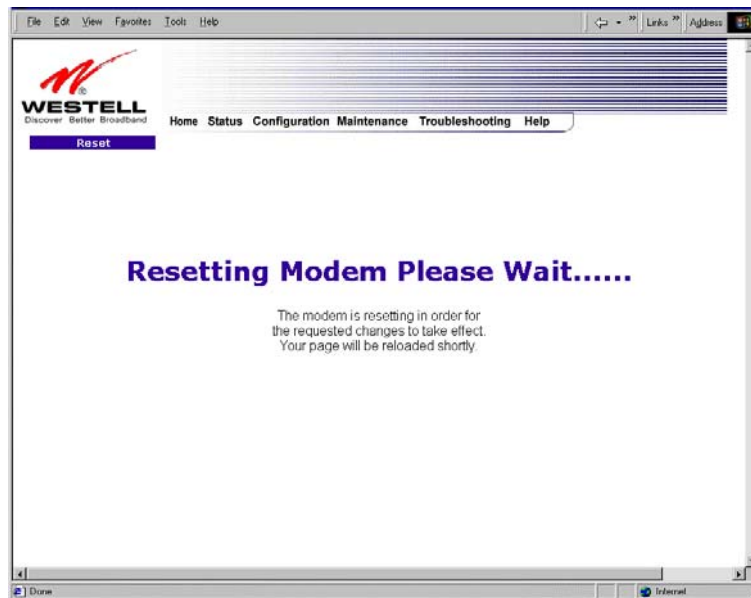

After a brief delay, the home page will be displayed. Confirm that you have a DSL sync and that your PPP session displays **UP**. (Click on the **connect** button to establish a PPP session). Next, Select **Single Static IP** from the **Configuration** menu to confirm that Single Static IP is **disabled**, as shown in the following screen.

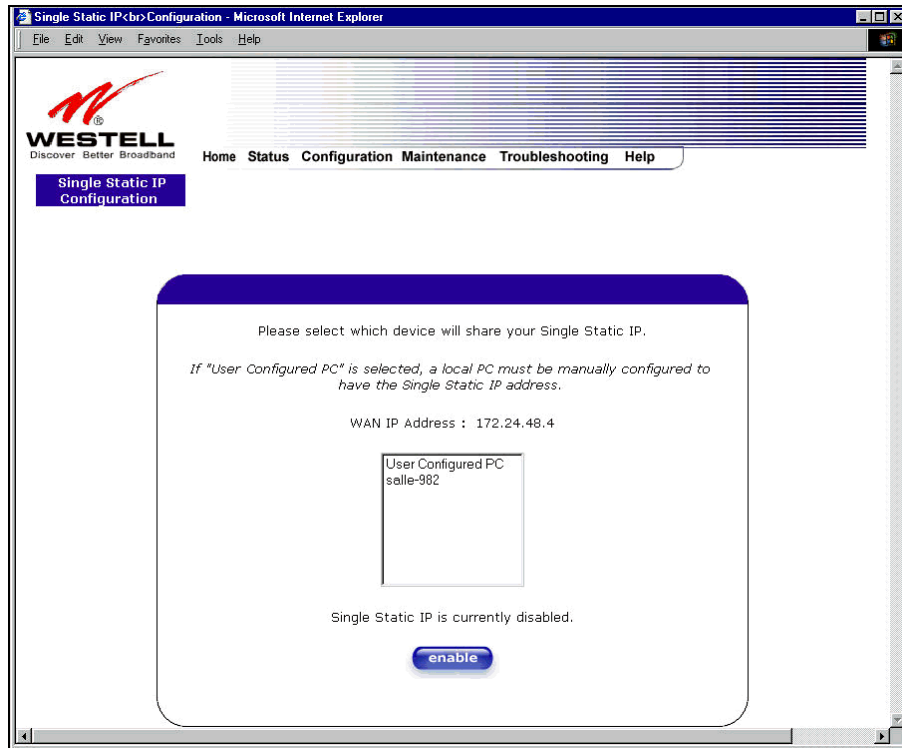

IMPORTANT: After you disable Single Static IP, you must reboot your computer.

12.2 Service Configuration

The following settings will be displayed if you select **Services** from the **Configuration** menu.

Westell has developed an extensive list of NAT services and you may select any service from this list. By selecting your specific NAT service and setting up a NAT profile, you will ensure that the appropriate ports on VersaLink are open and that the required application traffic can pass through your LAN. For a list of supported services, go to section 16 (NAT Services).

NAT Profiles allow you to create specific service settings. The NAT profile may then be associated with a connection profile, allowing you to customize profiles for specific users. For example, if you want to attach specific NAT services to a profile, or if you want to set up a different connection setting for a profile, you can create new NAT profiles and customize them to your preference.

NOTE: You may create up to four NAT profiles and attach an unlimited number of services to each profile.

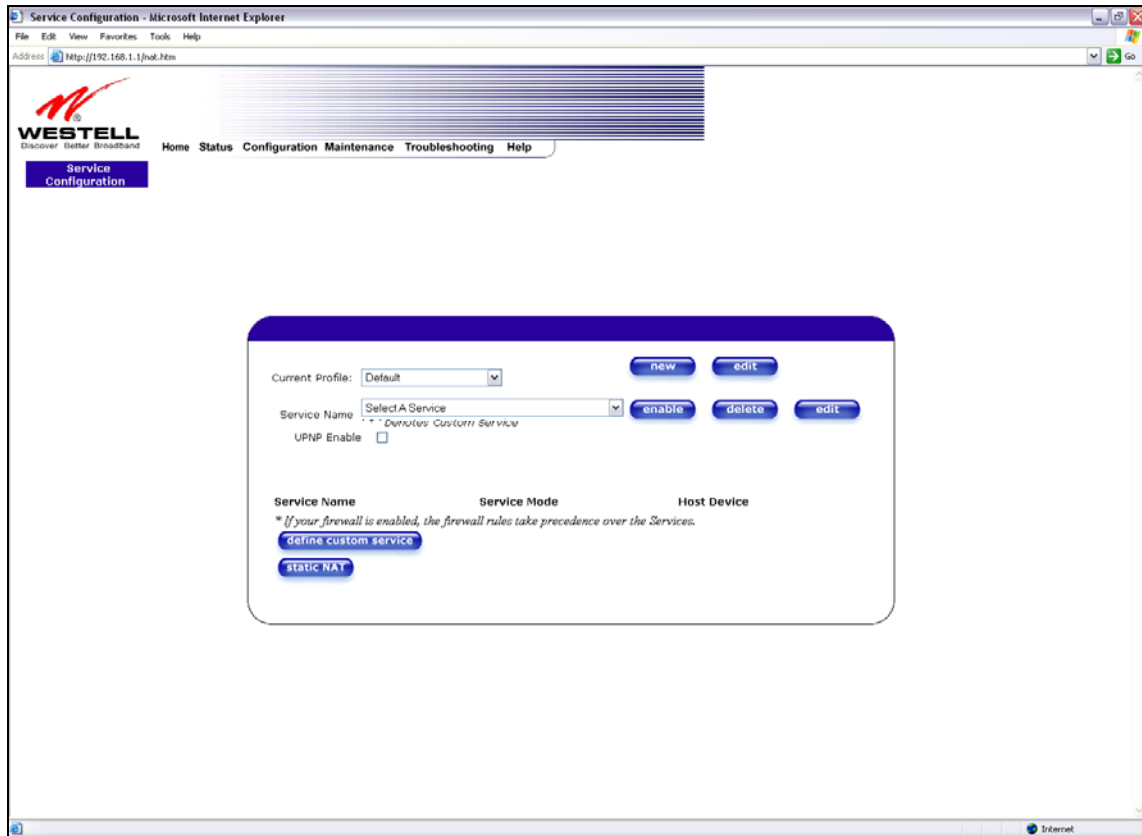

Current Profile	Displays the NAT (Network Address Translation) services that you have selected.
Service Name	Drop down selection menu of NAT (Network Address Translation) service you can select to configure you VersaLink.
UPNP Enable	Factory Default = Disable Enabling UPNP (Universal Plug and Play) allows automatic device discovery by your operating system.

12.2.1 Configuring UPNP on the VersaLink

To enable UPNP on the Gateway perform the following steps:

- 1) Select **Service Configuration** from the Configuration screen
- 2) Click the **UPNP Enable** box (a check mark will appear in the box).
- 3) Follow the instructions in the pop-up screens.
- 4) Click **OK** to Reset the Gateway.

NOTE: When you are ready to disable UPNP, uncheck the **UPNP Enable** box in the **Service Configuration** screen.

If you click the **UPNP Enable** box in the **Service Configuration** screen, a check mark will appear in the box and the following pop-up screen will be displayed. Click on **OK**.

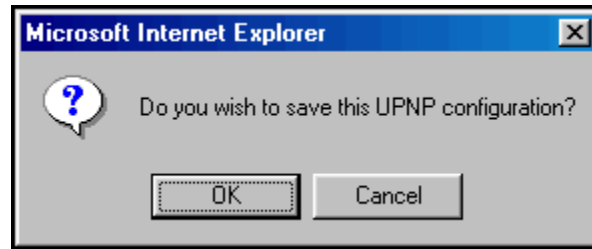

If you clicked **OK** in the preceding screen, the following pop-up screen will be displayed. Click on **OK** to reset the Gateway.

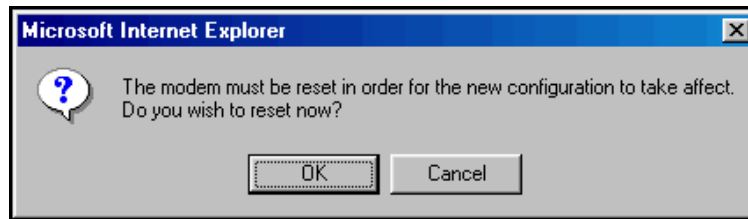

NOTE: To use the UPNP functionality in Versalink, your Windows XP operating system must also support UPNP. Please contact your computer manufacturer to verify that UPNP is enabled in your Windows XP operating system.

If you clicked **OK** in the preceding screen, the following screen will be displayed. The Gateway will be reset automatically, and the new configuration will take effect.

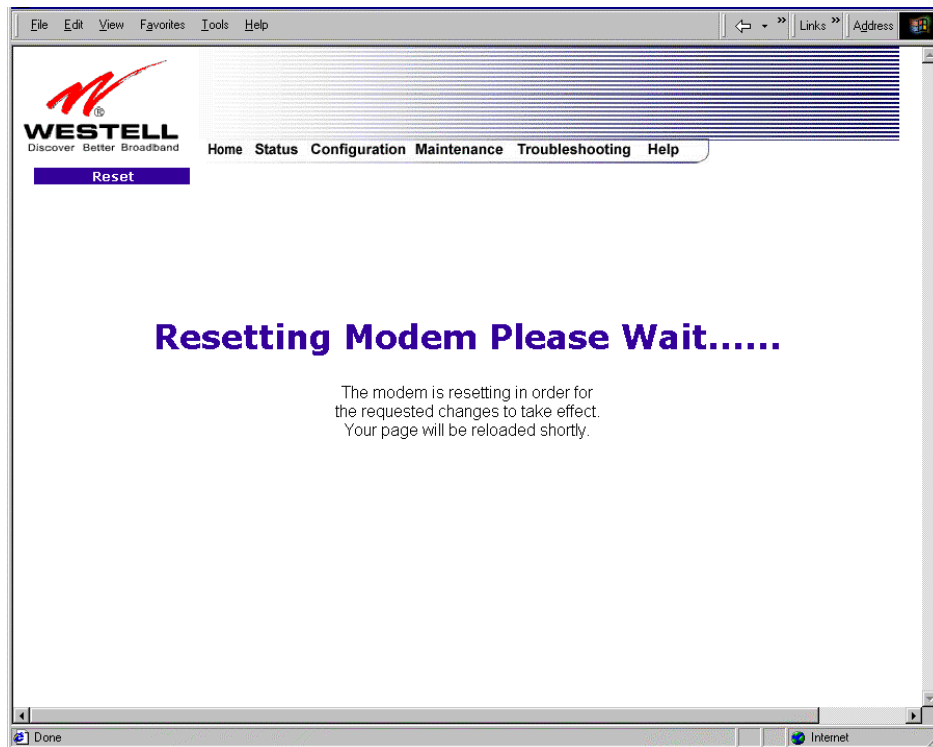

After a brief delay, the home page will be displayed. Confirm that you have a DSL sync and that your PPP session displays **UP**. (Click on the **connect** button to establish a PPP session).

12.2.2 Creating a New NAT Service Profile

NAT Profiles allow you to create specific service settings. The NAT profile may then be associated with a connection profile, allowing you to customize profiles for specific users. For example, if you want to attach specific NAT services to a profile, or if you want to set up a different connection setting for a profile, you can create new NAT profiles and customize them to your preference.

NOTE: You may create up to four NAT profiles and attach an unlimited number of services to each profile.

To create a new NAT profile, click **new** in the **Service Configuration** screen.

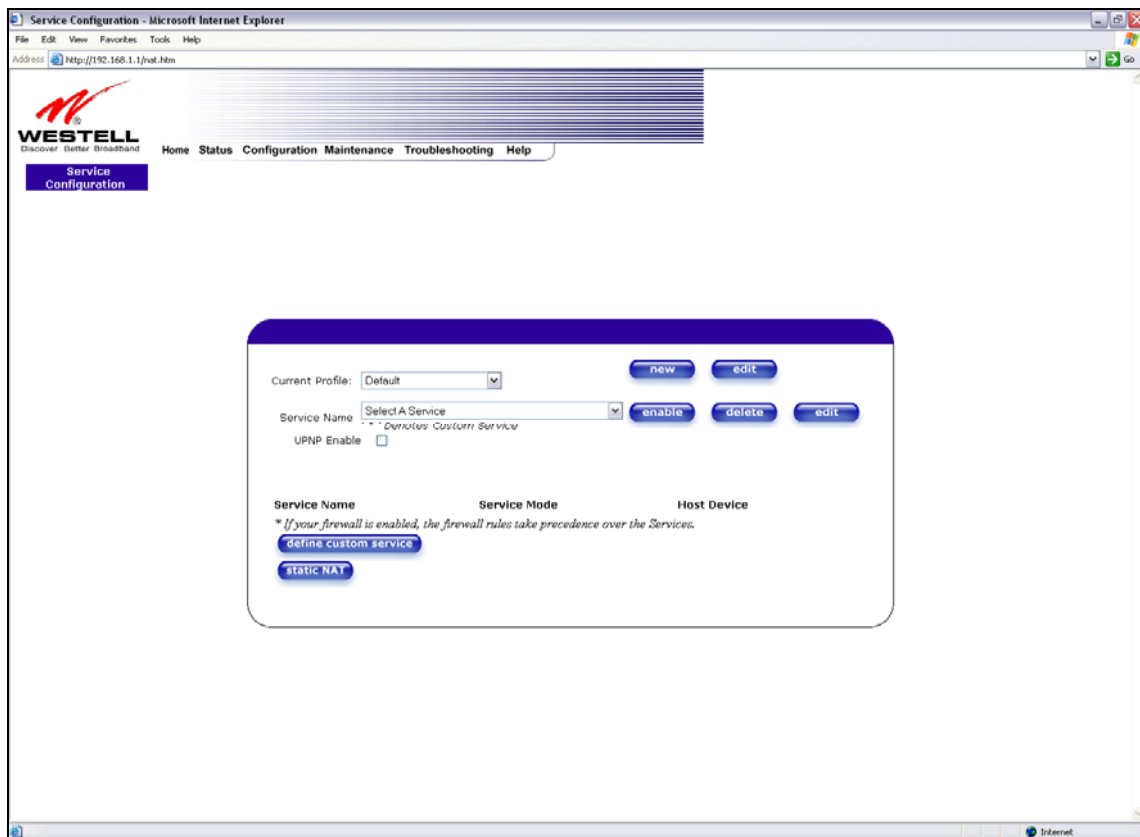

If you selected **new** from the preceding **Service Configuration** screen, the **Create new Service Profile?** pop-up screen will be displayed. Click on **OK** to begin creating your new NAT service profile. Click **Cancel** if you do not want to create a new NAT service profile.

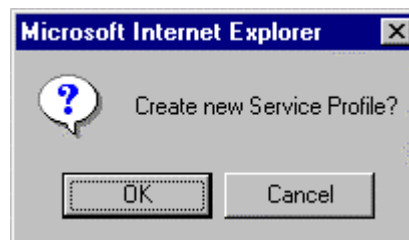

If you clicked **OK**, the following screen will be displayed. Select **“A New Service Profile #1”** from the **Current Profile** drop-down arrow.

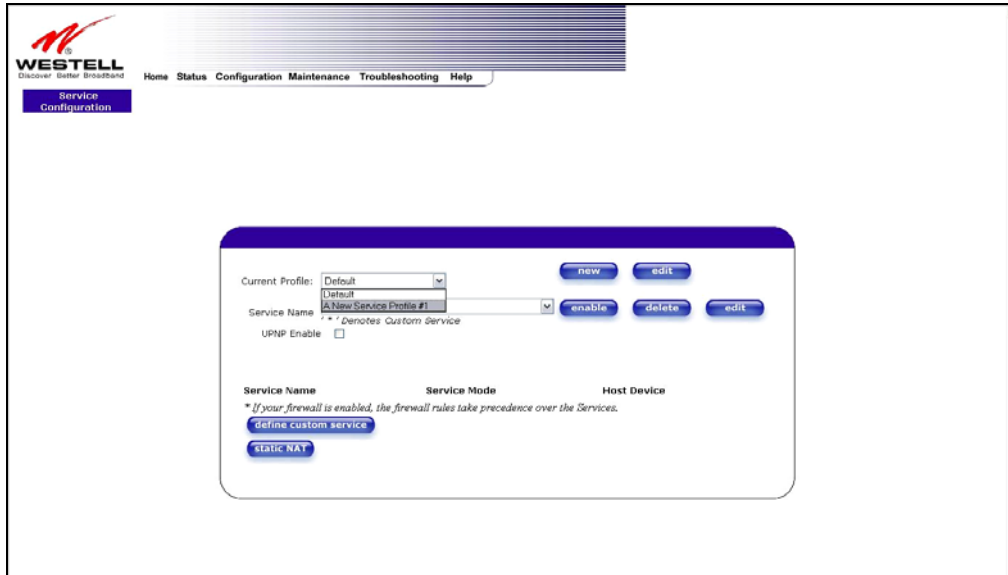

If you selected **“A New Service Profile #1”** from the **Current Profile** drop-down arrow, the following screen will be displayed. This screen shows that you have chosen to create a new NAT service profile. You may create up to four NAT service profiles and attach an unlimited number of services to each profile.



12.2.3 Editing a NAT Service Profile

After you have created a NAT service profile, you may edit the profile's name. If you select **edit** from the **Service Configuration** screen, the following screen will be displayed. By selecting the **edit** button, you can make changes to your profile name, and then add NAT services to or delete them from your profile. Type your new NAT service profile name in the field labeled **Profile Name**.



The following screen shows that a new profile name called 'My NAT Profile' was entered into the **Profile Name** field. If you want to save the new profile, click on **save**. If you do not want to save the new NAT profile, click **close**.

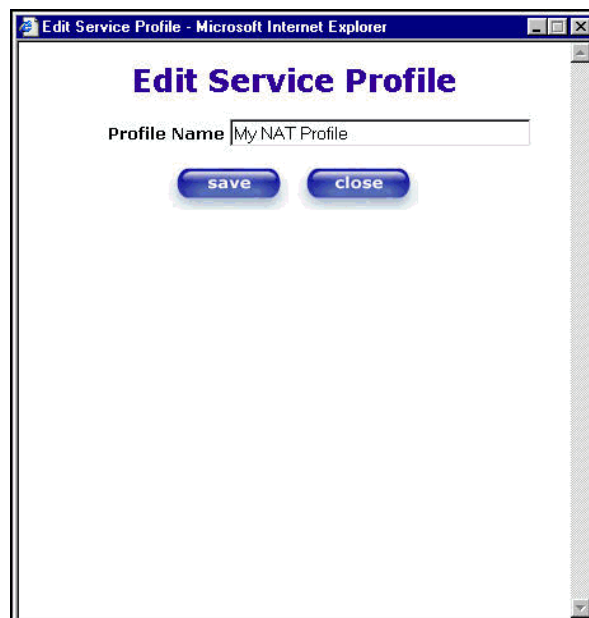

If you clicked **save** in the **Edit NAT Profile** screen, the following pop-up screen will be displayed. Click **OK** to save your new profile settings. If you click on **Cancel**, your new profile settings will not be saved.



The following screen displays the current profile. If desired, you may create a new profile and delete or edit an existing profile.

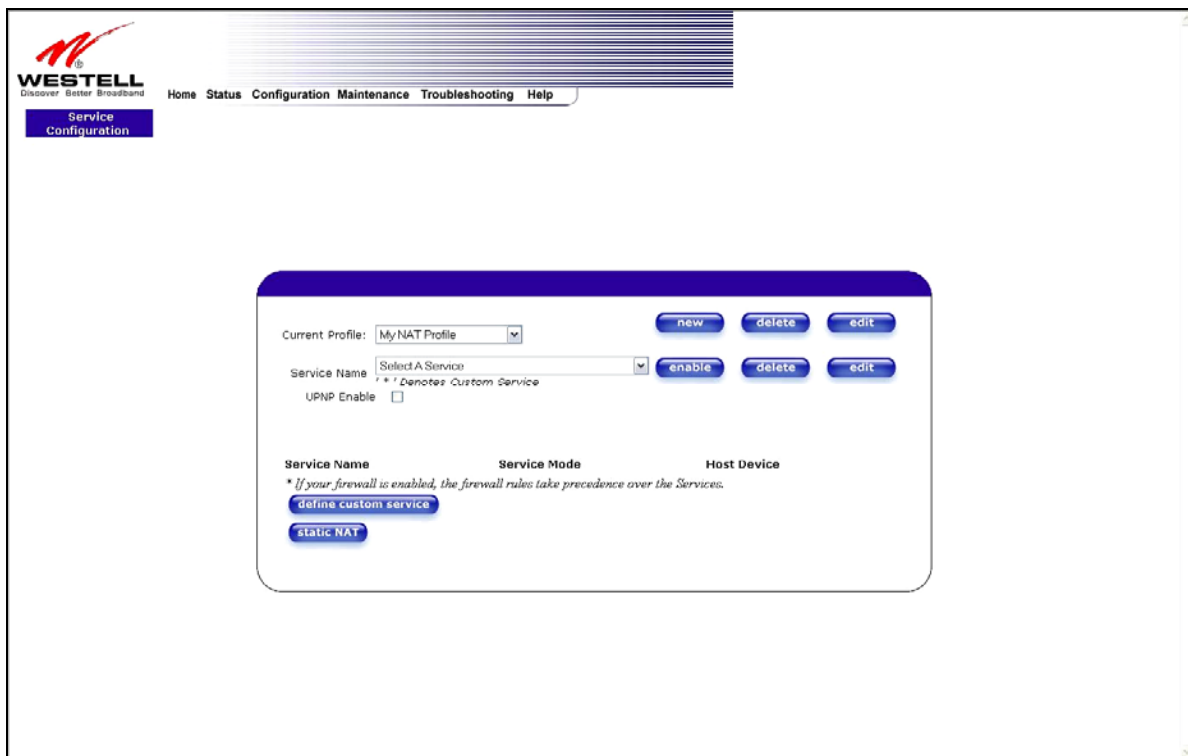

12.2.4 Adding NAT Services to a Profile

This section explains how to add NAT services to your NAT service profile. Remember, you may attach an unlimited number of NAT services to any profile.

NOTE: Westell has developed an extensive list of NAT services and you may select any service from this list. By selecting your specific NAT service and setting up a NAT profile, you will ensure that the appropriate ports on VersaLink are open and that the required application traffic can pass through your LAN. For a list of supported NAT services, go to section 16 (NAT Services).

To add a NAT service, select **Services** from the **Configuration** menu. Next, Select a NAT service from the options provided at the **Service Name** drop-down arrow.

NOTE: You can attach multiple NAT services to your profile. However, for each NAT service that you attach to your profile, you must first select the new NAT service. Then, you must load the new NAT Configuration, as explained in section 12.2.2.

In the following screen, the 'Default' profile has been selected as the profile that will host the selected NAT service. However, you can attach a NAT service to any profile.

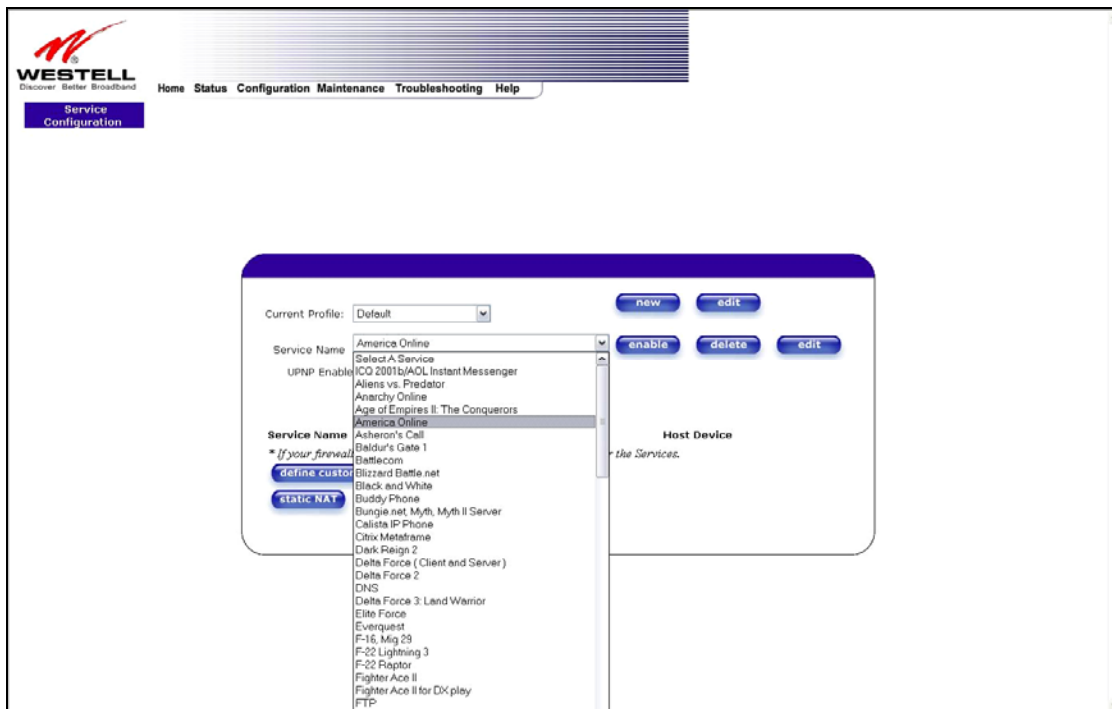

For example, the screen below displays **America Online** as the NAT service selected. After you have selected a service, click **enable**.

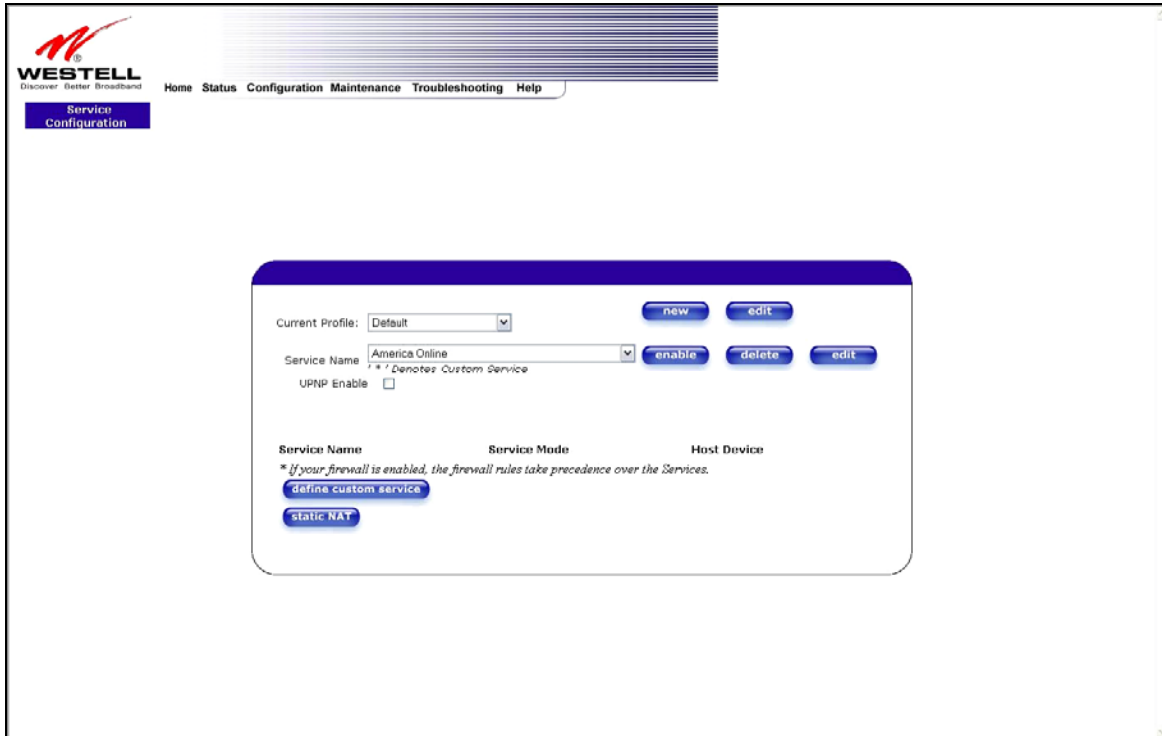

If you click **enable**, the following pop-up screen will be displayed. If you click **OK**, you will allow incoming connections to be forwarded to a designated local PC. If you click **Cancel**, you will allow only outgoing connections from any local PC. Click **OK** or click **Cancel**.

NOTE: If you click **Cancel** in the following pop-up screen, the NAT service you selected in the **Service Configuration** screen is still configured; however, it will not be assigned to any device on the local LAN. You must click **OK** to host the NAT service.

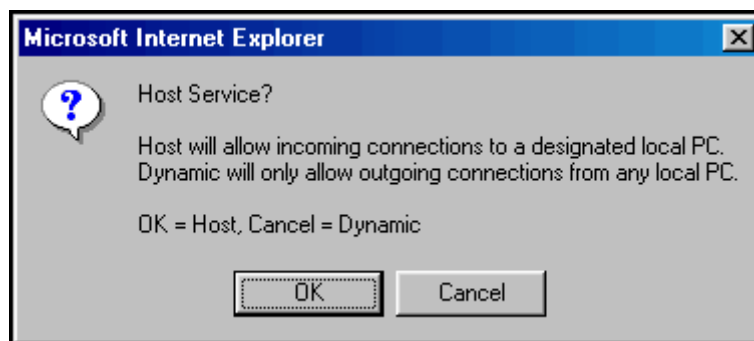

If you clicked **OK** in the preceding pop-up screen, the **Host Device** screen will be displayed. The **Host Device** screen will allow you to select which device will host the NAT service you selected on your local area network. You must either select the device from the **Host Device** drop-down arrow or type an IP address in the field labeled **IP Address**. If you click on **Cancel**, the connection will be dynamically assigned. Click on **done**.

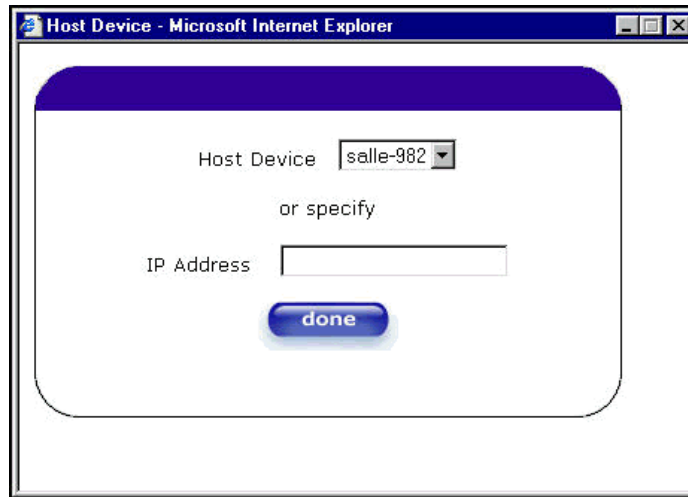

After you have selected a NAT service and you have saved it to your NAT service profile, the following screen will be displayed. It shows which NAT service is active for the selected profile.



If you select the **details** button in the **Service Configuration** screen, the following screen will display the details of the selected NAT service. If you click on the **delete** button in the **Service Configuration** screen, you will remove that NAT service from your NAT service profile. Click **close** to continue.

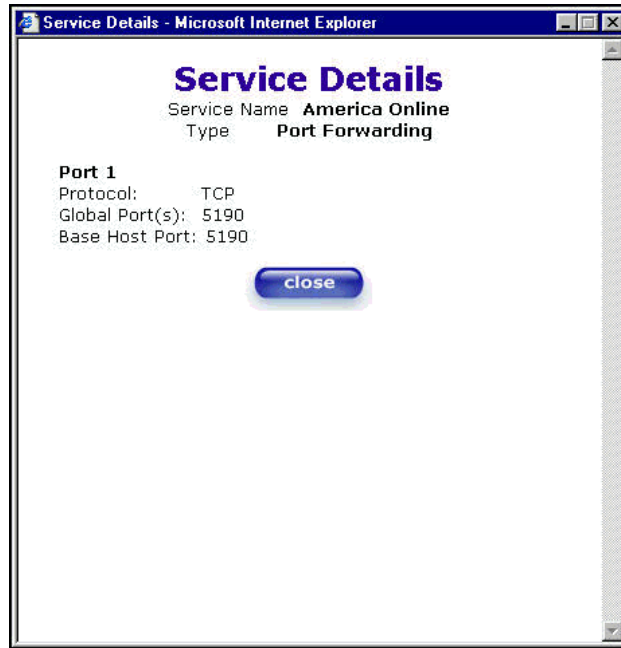

NOTE: If you would like to set up additional Advanced Service Configuration options, refer to section 13 (Setting Up Advanced Service Configuration).

12.3 Firewall Configuration

The following settings will be displayed if you select **Firewall** from the **Configuration** menu.

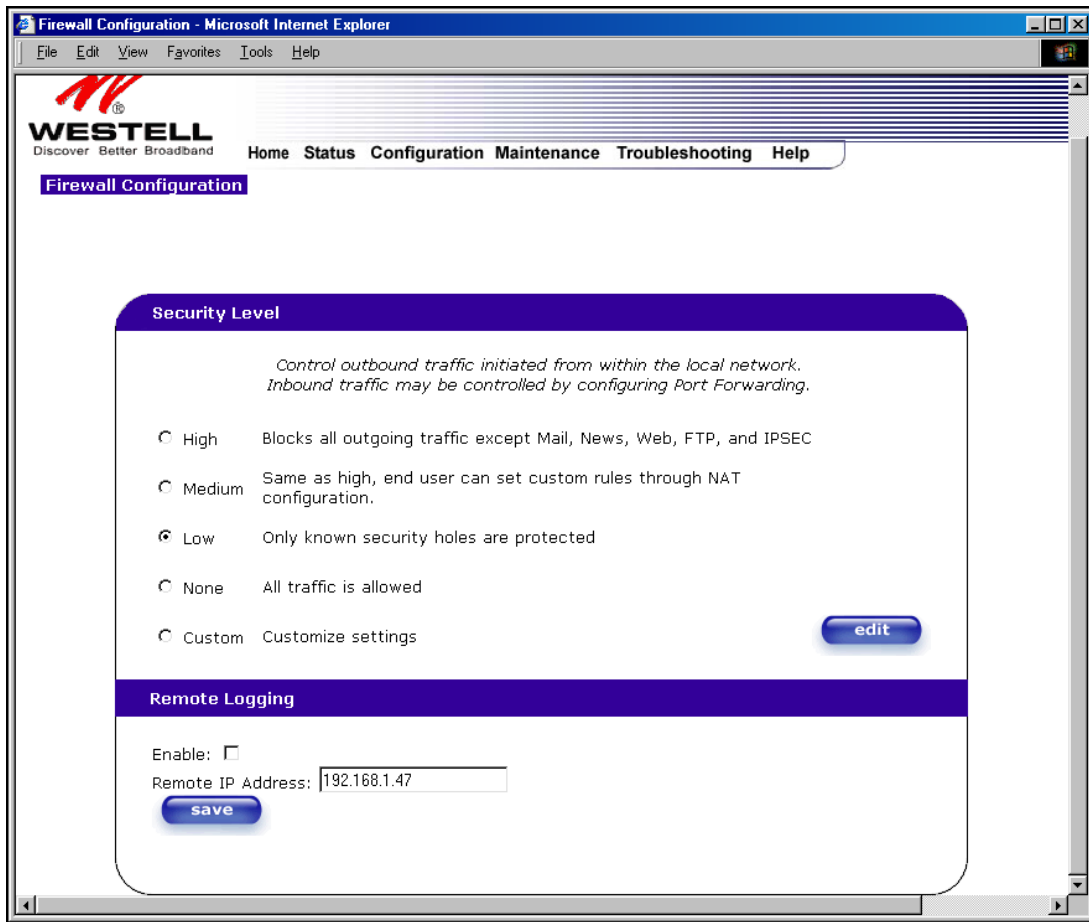

Security Level	
High	High security level only allows basic Internet functionality. Only Mail, News, Web, FTP, and IPSEC are allowed. All other traffic is prohibited.
Medium	Like High security, Medium security only allows basic Internet functionality by default. However, Medium security allows customization through NAT configuration so that you can enable the traffic that you want to pass.
Low	Factory Default = Low The Low security setting will allow all traffic except for known attacks. With Low security, VersaLink is visible to other computers on the Internet.
None	Firewall is disabled. (All traffic is passed)
Custom	Custom is an advanced configuration option that allows you to edit the firewall configuration directly. NOTE: only the most advanced users should try this.
Remote Logging	
Enable	Factory Default = Disable If enabled, VersaLink will send firewall logs to a syslog server.
Remote IP Address	The IP address of the syslog server machine to which the diagnostics logs to be sent.

If you select **Edit** from the **Security Level** screen, the **User Defined Firewall Rules** screen will be displayed. This screen allows you to change the security parameters on your Inbound and Outbound Firewall rules via the **User Defined Firewall Rules** drop-down arrow. If you select **Inbound**, this will restrict inbound traffic from the WAN to the LAN. **Outbound** restricts outbound traffic to the WAN from the LAN. To apply the new settings, click **Apply** in the screen labeled **User Defined Firewall Rules**.

NOTE: Westell recommends that you do not change the settings in the **User Defined Firewall Rules** screen. If you need to reset VersaLink to factory default settings, push the reset button on the rear of VersaLink.

The information displayed in the following screen depends upon the Firewall security setting you have selected. If you selected “None” in the preceding Firewall **Security Level** screen, no values will be displayed in the following **User Defined Firewall Rules** screen.

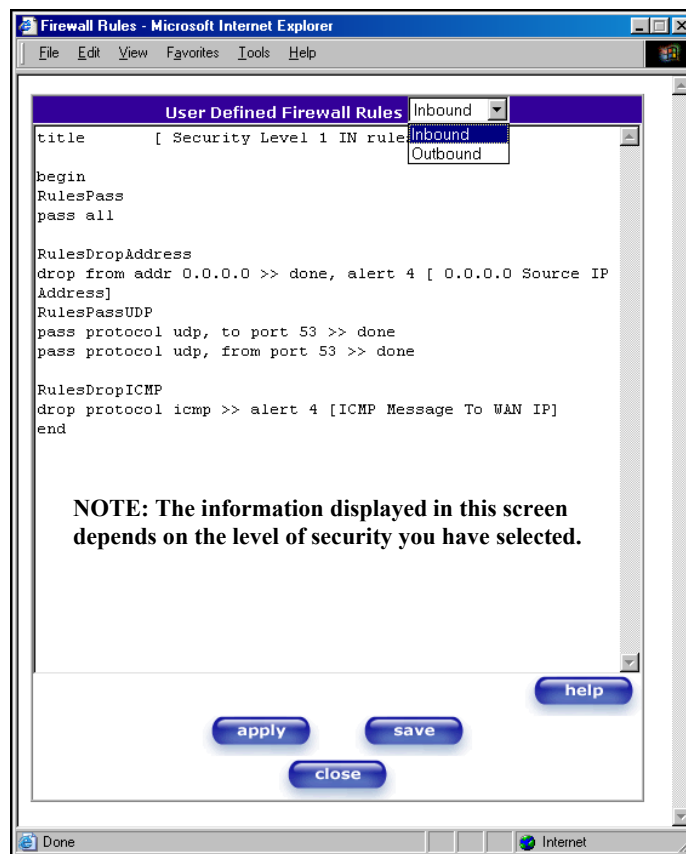

If you clicked **Apply** in the **User Define Firewall Rules** screen, the following pop-up screen will be displayed. Click on **OK** if you want your new firewall setting to take effect. If you click **Cancel**, your new firewall settings will not take effect.



If you want to save your new firewall settings, click **save** in the screen labeled **User Define Firewall Rules**.

NOTE: Westell recommends that you do not change the settings in the **User Defined Firewall Rules** screen. If you need to reset VersaLink to factory default settings, push the reset button on the rear of VersaLink.

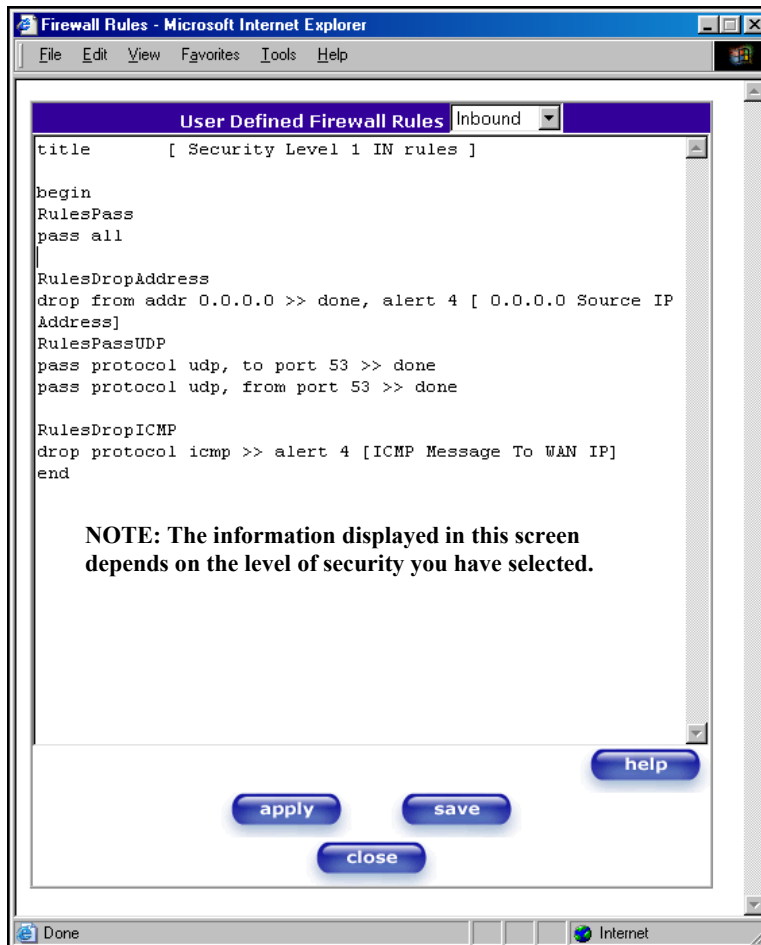

If you clicked **save** in the User Define Firewall Rules screen, the following pop-up screen will be displayed. Click **OK** when asked **Do you wish to save these Rules to Flash and switch your Security Level to "User"?** This will save your new firewall settings. If you click **Cancel**, your new firewall settings will not be saved.



If you select **Help** in the screen labeled **User Defined Firewall Rules**, the following screen will be displayed. This screen gives a detailed explanation of the Firewall Rules.

File/Buffer Format

The RDL file or buffer format is divided into two sections. The first portion of the file defines any number of keys and associated values. The second portion contains the filtering rule definitions.

Key Definition Section

A key definition consists of the key followed by the associated value. A value is actually a character string. The string is delimited by the open and close square brackets. An example of a keyword definition would look like the following.

```
title [ High security RDL file ]
```

The packet filter engine does not use keys. They are intended to provide information associated with the file. The user interface treats the key definition and value pairs as standard text.

Rules Section

The rules section of the RDL file or buffer is delimited by the **begin** and **end** keywords. The rules listed between these delimiters are parsed and converted to a decision tree data structure used by the packet filter engine. The rules listed are implemented sequentially as listed in the RDL source. Once the packet filter engine finds a match for a rule it will note the filter action to be taken (pass or drop) and continue to compare the following rules with the given packet unless otherwise instructed (see the description of the **done** action in section 3.2.1.2.3).

Rule Names

RDL rules may be given names. The packet logging facility and the user interface uses these rule names. A name applies to all rules following its declaration in the Rules Section until another name is declared or the end statement. An identifier (one or more alphanumeric characters beginning with an alpha character) on a line by itself declares a new name for the following rule(s).

RDL Comments

Comments begin with the # character. The parser ignores all characters following the comment character to the end of the line.

RDL Command Syntax

An RDL command consists of a filter keyword followed by a condition expression optionally followed by one or more action keywords.

```
Filter Condition [ Condition2, ] [ => Action, Action2, ]
```

The filter keyword specifies if the packet will be passed or dropped. The condition defines the portion of the packet and the bit string to which it will be compared. The action keyword may specify additional action(s) to be taken.

Filter Keywords

The RDL filter token may be either passed or dropped.

- pass** Specifies that the matching packet is to be passed onto the associated interface or the SENS MUX.
- drop** Specifies that the matching packet will not be forwarded to the associated interface or the SENS MUX.

Condition Keywords

The condition expression determines if the rule is a match for the given packet.

- all** Specifies all packets. If the all condition is specified in a rule, all other conditions are ignored.
- match layer offset [M-string/mask]** Specifies one or more explicit bit strings and offsets into the layer header to compare. This keyword is followed by three parameters. The first numeric parameter is the header layer, valid values include 2 through 4 (Ethernet = 2, ip = 3, tcp/udp/icmp/igmp = 4). The second numeric parameter is the offset into the packet to begin the comparison. 1 and the third third parameter, is the representation of the bit string and comparison bit mask/offset. The bit string is delimited with the open and close curly braces {}. A colon delimits the bit string and mask. If no mask is provided, a mask value of all ones is assumed. Each byte of the bit string and mask is represented by a two character hexadecimal number and is separated by white space from the previous byte representation.
- from [to [addr [p-addr/mask]] [port port_n port >= port_n | port >= port_n]]** Specifies particular fields (IP address or TCP/UDP port number) of the IP header. The **from** keyword designates the source fields, and the **to** keyword designates the destination fields. One or more ***** descriptors of the fields and their contents then follows the keyword. A list of descriptors is to be separated by colon(s). These field descriptors include addr (IP address), mask (network mask), and port (TCP or UDP port number).
 - addr** Specifies the source or destination IP address field and comparison mask. This keyword is followed by a IP address in dotted-decimal notation and mask separated by a forward slash. The mask is a number from 1 to 32 and it signifies how many bits of the IP address are compared. If no mask is provided, a mask value of 32 is assumed.
 - port** Specifies the source or destination UDP/TCP port number. This keyword is followed by the 16 bit port number represented hexadecimal or decimal format. Using the >= or > operators allows for matching on ranges of ports.
- protocol tcp | udp | icmp | igmp | value** Specifies the value of the protocol field found in the IP header. It is followed by a parameter that specifies the protocol value. These are built-in keywords for the TCP, UDP, ICMP, and IGMP protocols. If a different protocol value is required, it may be represented by a decimal or hexadecimal value between 0 and 255.
 - tcp** Specifies the TCP protocol.
 - udp** Specifies the UDP protocol.
 - icmp** Specifies the ICMP protocol.
 - igmp** Specifies the IGMP protocol.
- flags urg | ack | psh | rst | syn | fin** Specifies some combination of the flag bits found in the TCP header. The parameters following the keyword should be represented in a colon delimited list.
 - igmp-type query | report** Specifies the IGMP packet type found in the IGMP header. The **report** type checks for both version 1 and version 2 type codes. No check is made by the parser to verify that the IGMP protocol is specified. So it is up to the user to include the **protocol igmp** condition in a rule using the **igmp-type** condition.
 - icmp-type request | reply** Specifies the ICMP packet type found in the ICMP header. No check is made by the parser to verify that the ICMP protocol is specified. So it is up to the user to include the **protocol icmp** condition in a rule using the **icmp-type** condition.

Action keywords

Specifies any further action to be taken upon a match between the rule condition and the packet content.

- log level** Specifies that the contents of any matching packet header should be recorded in the log table. The level parameter is a mechanism to indicate the source of the log entry. This value rule name is stored with each log entry resulting from this rule. The log may subsequently be searched or sorted by this value rule name. Log entries appear in the table with a default severity of 0. The level value is represented by a decimal or hexadecimal value between 0 and 255.
- alert severity [Alert text]** Specifies that the contents of any matching packet header should be recorded on the log table with the corresponding severity value and text explanation. Severity is a decimal number between 0 and 4. The alert text is delimited by brackets/brackets delimit the alert text.
- done** Specifies that the filtering engine should stop checking any subsequent rules should this rule match. This action provides a mechanism to optimize the decision tree implemented by the filtering engine.
- state** Specifies that the TCP/ICMP/IGMP session (particularly the sequence number in the case of TCP and the packet type and source/destination addresses and ports in the case of ICMP and IGMP) associated with this packet will be added to the state table maintained by the filtering engine. As long as that session remains in the state table all packets associated with that session are passed without consulting them to the rules decision tree. The filtering engine state table logic maintains the state of the session with successive packets and closes or times it out (removes it from the state table) whenever appropriate.

12.4 Wireless Configuration

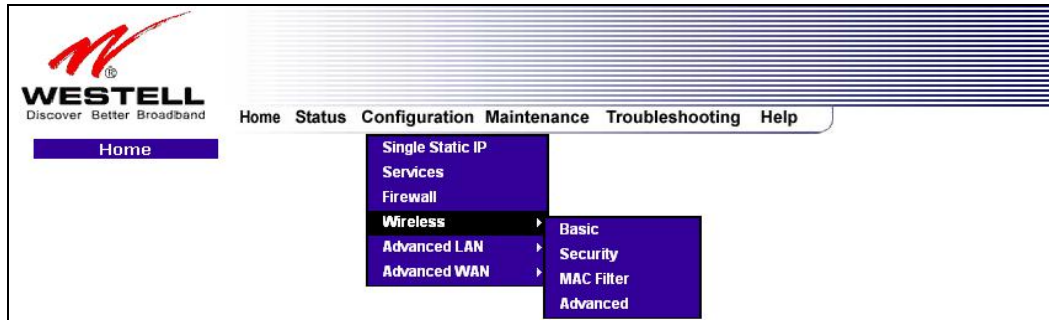

12.4.1 Wireless Basic

The following fields will be displayed if you select **Wireless** and then select **Basic** from the **Configuration** menu.

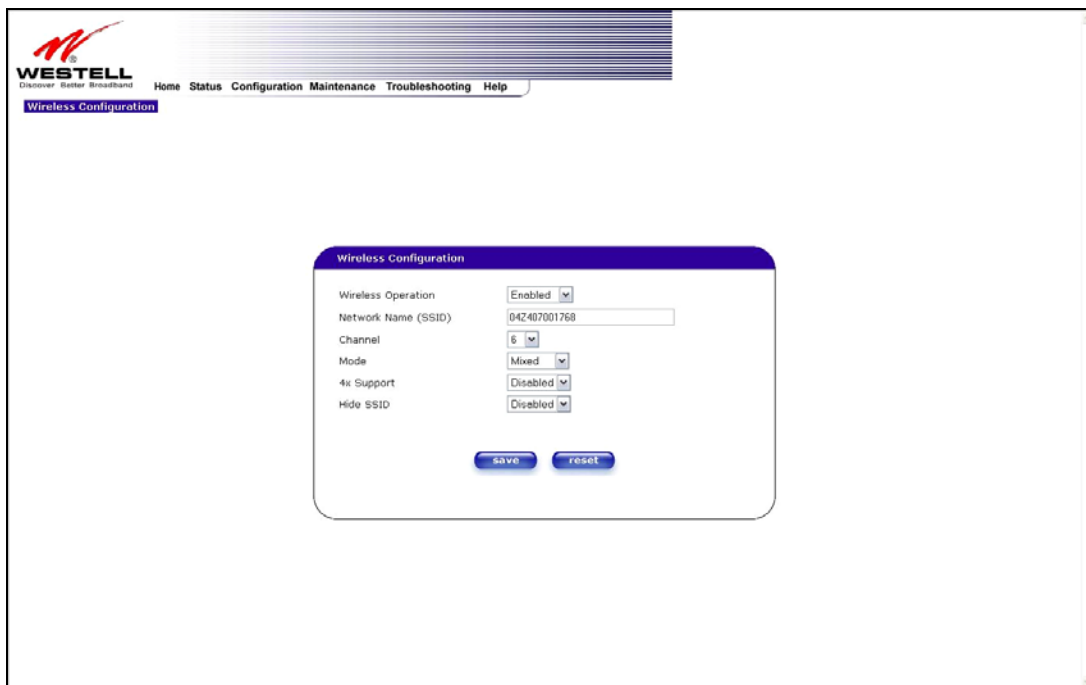

IMPORTANT: If you are connecting to VersaLink via a wireless network adapter, the service set ID (SSID) must be the same for both the Westell VersaLink and your PC's wireless network adapter. The default SSID for VersaLink is the serial number of the unit (located below the bar code on the bottom of the unit and also on the Westell shipping carton). Locate and run the utility software provided with your PC's Wireless network adapter and enter the SSID value. The PC's wireless network adapter must be configured with the SSID (in order to communicate with VersaLink) before you begin VersaLink's account setup and configuration procedures. For privacy, you should change the **Network Name (SSID)** value in the **Wireless Configuration** screen to your desired value.

Wireless Configuration	
Wireless Operation	Factory Default = Enabled. When disabled, no stations will be able to connect to the VersaLink.
Network Name (SSID)	This string, (32 characters or less) is the name associated with the AP. To connect to the AP, the SSID on a Station card must match the SSID on the AP card or be set to "ANY."
Channel	Factory Default = 6 The AP transmits and receives data on this channel. The number of channels to choose from is pre-programmed into the AP card. Station cards do not have to be set to the same channel as the AP; the Stations scan all channels, and look for an AP to connect to.
Mode	Factory Default = Mixed This setting allows station to communicate with VersaLink. Possible Responses: Mixed: Station using any of the 802.11b, 802.11b+, and 802.11g rates can communicate with VersaLink. 11b only: Communication with VersaLink is limited to 802.11b 11b+: Stations using any of the 802.11b and 802.11b+ rates can communicate with VersaLink 11g only: Communication with VersaLink is limited to 802.11g
4x Support	Factory Default = Disabled When selected, this enables/disables the 4X option. If enabled, 4X support provides additional algorithms for increased throughput. The station cards must also support this option.
Hide SSID	Factory Default = Disabled. If Enabled, VersaLink will not broadcast the SSID. Stations must configure the SSID to match the Network Name (SSID) to connect to VersaLink.

If you click **save** in the **Wireless Configuration** screen, the following pop-up will be displayed. Click **OK** to save the settings.

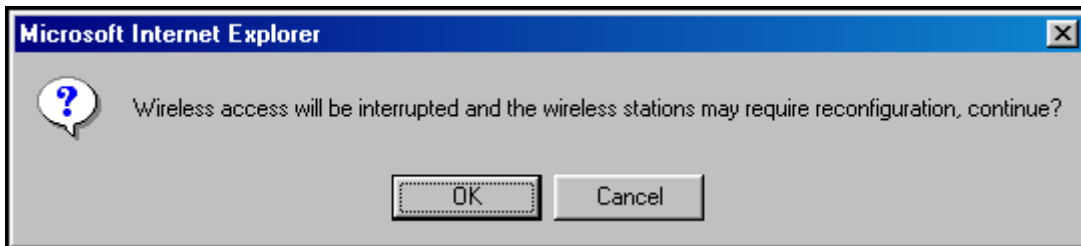

12.4.2 Wireless Security

The following screen will be displayed if you select **Wireless** and then select **Security** from the **Configuration** menu.



At the **Wireless Security** drop-down menu, select the desired security option.

IMPORTANT: Client PCs can use any Wireless Fidelity (Wi-Fi) 802.11b/g/g+ certified card to communicate with VersaLink. The Wireless card and VersaLink must use the same security code type. **If you use WPA-PSK or WEP wireless security, you must configure your computer's wireless adapter for the security code that you use.**

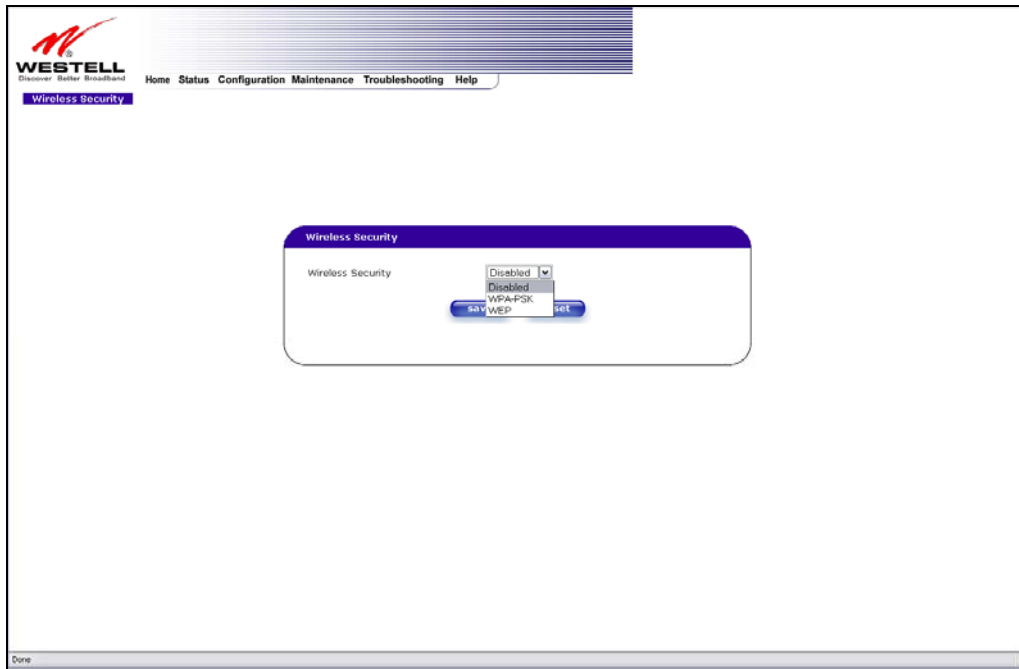

If you select **WPA-PSK** from the **Wireless Security** drop-down menu, following screen will be displayed. Enter you WPA Shared Key in the field provided. Next, enter the WPA Group Rekey Interval value. Click **save** to save the settings.

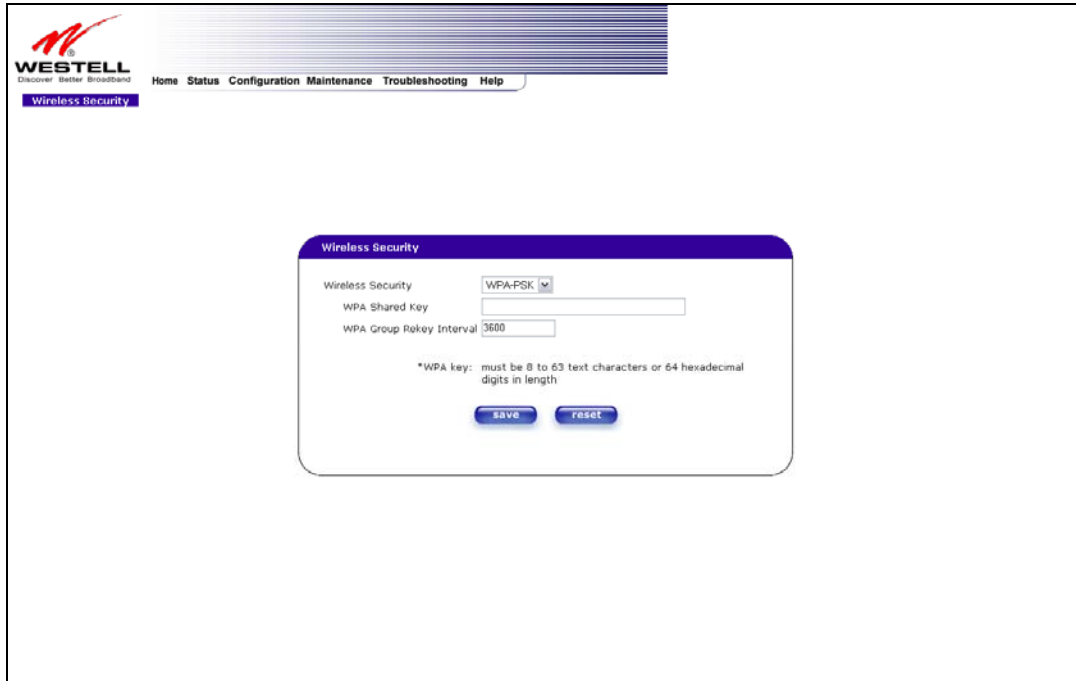

Wireless Security	
Wireless Security	<p>Factory Default = Disabled.</p> <p>Possible Response:</p> <p>Disabled: Wireless security will be disabled on the VersaLink.</p> <p>WPA-PSK: Selecting this will enable you to set up WPA-PSK security on the VersaLink.</p> <p>WEP: Selecting this will enable you to set up WEP security on the VersaLink. The AP card supports 64-bit, 128-bit, or 256-bit WEP encryption. If WEP is selected, any station can connect to the AP (as long as its SSID matches the AP SSID).</p> <p>If wireless security is disabled, the risk of someone nearby accessing the AP is maximized</p>
WPA Shared Key	<p>This is a passphrase (also called a shared secret) that must be entered in both the wireless router and the wireless client. This shared secret can be between 8 to 63 text characters (or 64 hexadecimal characters) and can include special characters and spaces. The WPA Shared Key should be a random sequence of either keyboard characters (upper and lowercase letters, numbers, and punctuation), at least 20 characters long, or hexadecimal digits (numbers 0-9 and letters A-F) at least 24 hexadecimal digits long. The more random your WPA Shared Key, the safer it is to use.</p>
WPA Group Rekey Interval	<p>Factory Default = 3600</p> <p>The number of seconds between rekeying the WPA group key. A zero "0" means that rekeying is disabled.</p>

If you select **WEP** from the **Wireless Security** drop-down menu, the following screen will be displayed. After you have entered the appropriate values in the fields provided, click **save** to save the settings.

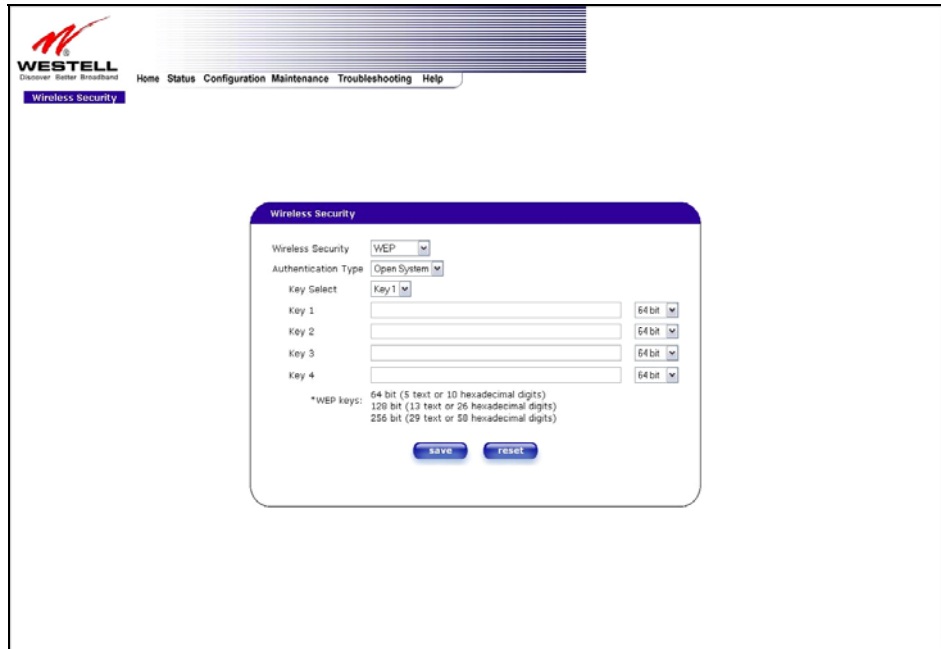

Wireless Security	
Wireless Security	<p>Factory Default = Disabled.</p> <p>Possible Response:</p> <p>Disabled: Wireless security will be disabled on the VersaLink.</p> <p>WPA-PSK: Selecting this will enable you to set up WPA-PSK security on the VersaLink.</p> <p>WEP: Selecting this will enable you to set up WEP security on the VersaLink. The AP card supports 64-bit, 128-bit, or 256-bit WEP encryption. If WEP is selected, any station can connect to the AP (as long as its SSID matches the AP SSID). If wireless security is disabled, the risk of someone nearby accessing the AP is maximized.</p>
Authentication Type	<p>Factory Default = Open System</p> <p>Possible Response:</p> <p>Open System: Open System authentication is the default selection.</p> <p>Shared Key: To use Shared Key authentication, WEP must be enabled, and a valid WEP key must be present. Enabling WEP does not force the use of Shared Key authentication. It is permissible to have WEP enabled and still use Open System authentication.</p>
Key Select	<p>If selected, the WEP Key is treated as a string of text characters, and the number of characters must be either 5 (for 64-bit encryption) or 13 (for 128-bit encryption) or 29 (for 256-bit encryption). If not selected, the WEP key is treated as a string of hexadecimal characters, and the number of characters must be either 10 (for 64-bit encryption), 26 (for 128-bit encryption), or 58 (for 256-bit encryption). The only allowable hexadecimal characters are 0-9 and A-F.</p> <p>NOTE: The WEP key must be the same value and type for both VersaLink and the wireless network adapter. “Pass Phrase” is not the same as “text” and should not be used.</p>

12.4.3 Wireless MAC Filter Table

The following screen will be displayed if you select **Wireless** and then select **MAC Filter** from the **Configuration** menu. To enable MAC Address filtering, click the box adjacent to **Enable MAC Address Filtering**. A check mark will appear in the box. Next, click **save** to save the setting. To add or edit a MAC Address setting, click the **add** button.

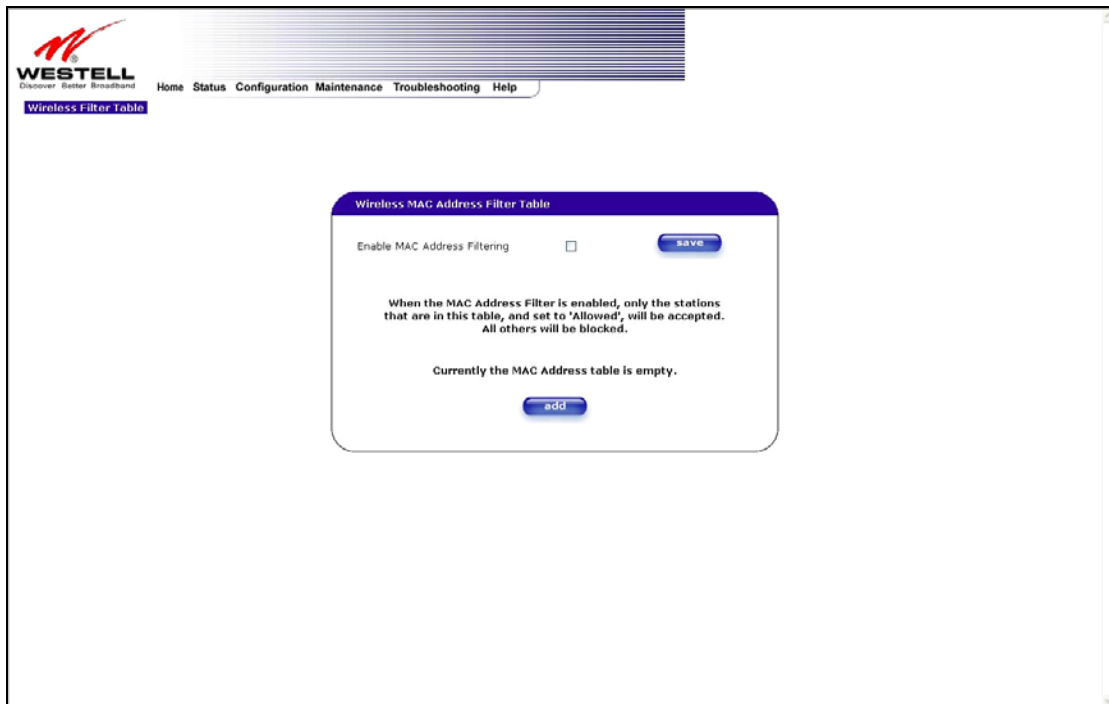

If you click **add** in the preceding screen, the following screen will be displayed. Enter the appropriate values for your MAC Address settings, and then click **save** to save the settings. Click **cancel** if you wish to return to the preceding screen.

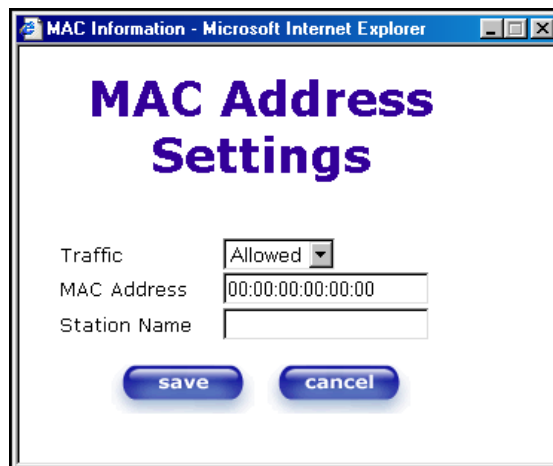

Traffic	Allowed: When the MAC Filter is enabled, only stations in the MAC Filter Table (which are set to “Allowed”) will have access to the AP. Blocked: This allows the station to remain in the table, but no access to the VersaLink is allowed.
MAC Address	The MAC address assigned to the station that you want to allow access to.
Station Name	The station name or description that the MAC address is assigned to. This is an optional field that is useful in identifying the station.

12.4.4 Wireless Advanced Configuration

The following screen will be displayed if you select **Wireless** and then select **Advanced** from the **Configuration** menu.

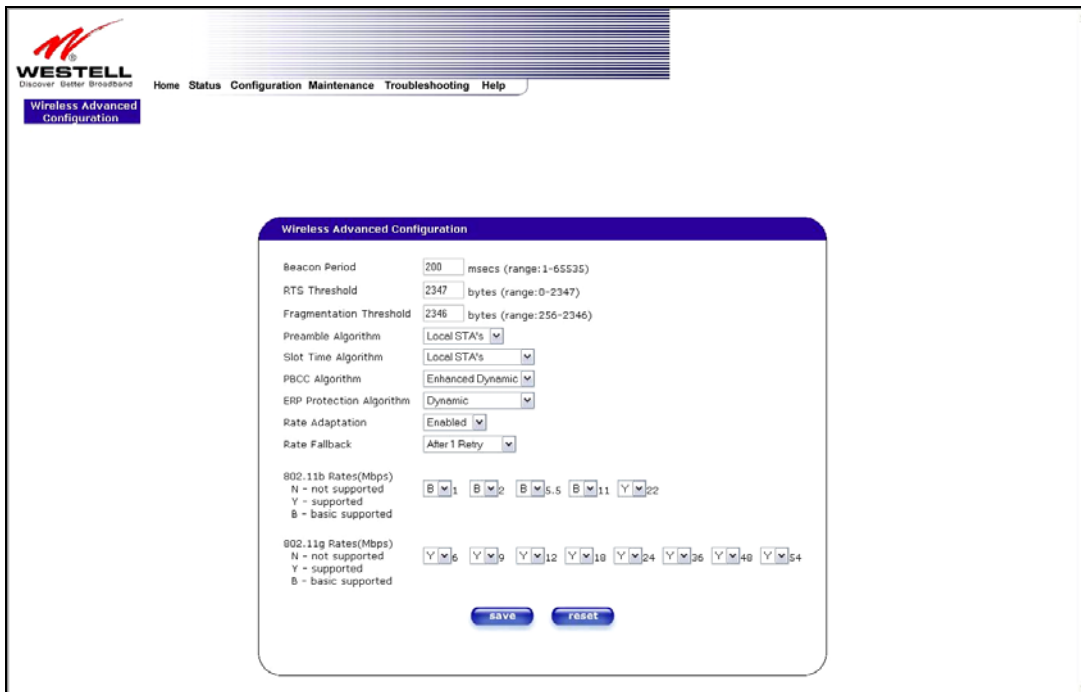

Wireless Advanced Configuration	
Beacon Period	The time interval between beacon frame transmissions. Beacons contain rate and capability information. Beacons received by stations can be used to identify the access points in the area.
RTS Threshold	RTS/CTS handshaking will be performed for any data or management MPDU containing a number of bytes greater than the threshold. If this value is larger than the MSDU size (typically set by the fragmentation threshold), no handshaking will be performed. A value of zero will enable handshaking for all MPDUs.
Fragmented Threshold	Any MSDU or MMPDU larger than this value will be fragmented into an MPDU of the specified size.
Preamble Algorithm	Factory Default = Local STA's Possible Responses: Always Long: Transmissions are done using the long preamble algorithm. Always Short: Transmissions are done using the short preamble algorithm. Local STA's: If all associated stations support short preamble, then the short

	<p>preamble algorithm is used. Otherwise, the long preamble algorithm is used.</p>
Slot Time Algorithm	<p>Factory Default = Local STA's</p> <p>Possible Response: Always Off: Transmissions are done using a 20 usec slot time. Always ON: Transmissions are done using a usec slot time (SST). Local STA's: If all associated stations support SST, then the 9 usec slot time is used. Otherwise, the 20 uses slot time is used. Enhanced Dynamic: Similar to Local STA's, with the following extension: If associated stations that do not support SST do not transmit for a period of time, the 9 usec slot time is used.</p>
PBCC Algorithm	<p>Factory Default = Enhanced Dynamic</p> <p>Possible Response: Always Off: PBCC is not used, operation at 22 Mbps is not possible. Always ON: PBCC is used. Local STA's: If all associated stations support PBCC, then PBCC is used. Otherwise, PBCC is not used. Dynamic: Similar to local STA's with the following extension: PBCC setting is also dependent on Beacon frames from overlapping BSS. If Beacon frames are received that do not support PBCC, then PBCC is not used. Enhanced Dynamic: Similar to Dynamic with the following extension: If associated stations that do not support PBCC do not transmit for a period of time, then PBCC is not used.</p>
ERP Protection Algorithm	<p>Factory Default = Dynamic</p> <p>Possible Response: Always Off: ERP is not used Always ON: ERP is used. Local STA's: If there are any associated stations than do not support ERP, a protection algorithm is used to prevent contention. Dynamic: Similar to local STA's with the following extension: The ERP protection setting is also dependent on Beacon frames from overlapping BSS. IF Beacon frames are received that indicate ERP is not supported, then a protection algorithm is used. Enhanced Dynamic: Similar to Dynamic with the following extension: If associated stations that do not support ERP do not transmit for a period of time, then protection algorithm is not used.</p>
Rate Adaptation	<p>Factory Default = Enable</p> <p>If disabled, the highest rate shared between VersaLink and STA is used for each transmission.</p>
Rate Fallback	<p>Factory Default = After 1 Retry</p> <p>The number of retries to attempt before falling back to the next lower rate. If Fallback is disabled, the starting rate is the only rate tried. IF Rate Adaptation is also disabled, the maximum rate shared with the STA is always the starting rate and the only rate tried. This may not work in noisy environments, and will reduce roaming distances.</p> <p>Possible Response: After 1 Retry/ Disable/ After 1 Retry/ After 2 Retry</p>
802.11b Rates (Mbps) 802.11g Rates (Mbps)	<p>These are the allowable communication rates that VersaLink will attempt to use. The rates are also broadcast within the connection protocol as the rates supported by VersaLink.</p>

12.5 Advanced LAN

This section explains the configurable features of VersaLink that are available if you select **Advanced LAN** from the **Configuration** menu.

NOTE: If VersaLink is configured for **ETHERNET PORT 1**, **VLAN** will not be displayed. You must configure VersaLink for **DSLATM PORT** to access **VLAN** in the **Advanced LAN** drop-down menu. Refer to section 12.6.2.1 for details.

12.5.1 DNS Configuration

The following settings will be displayed if you select **DNS** from the **Advanced LAN** menu.

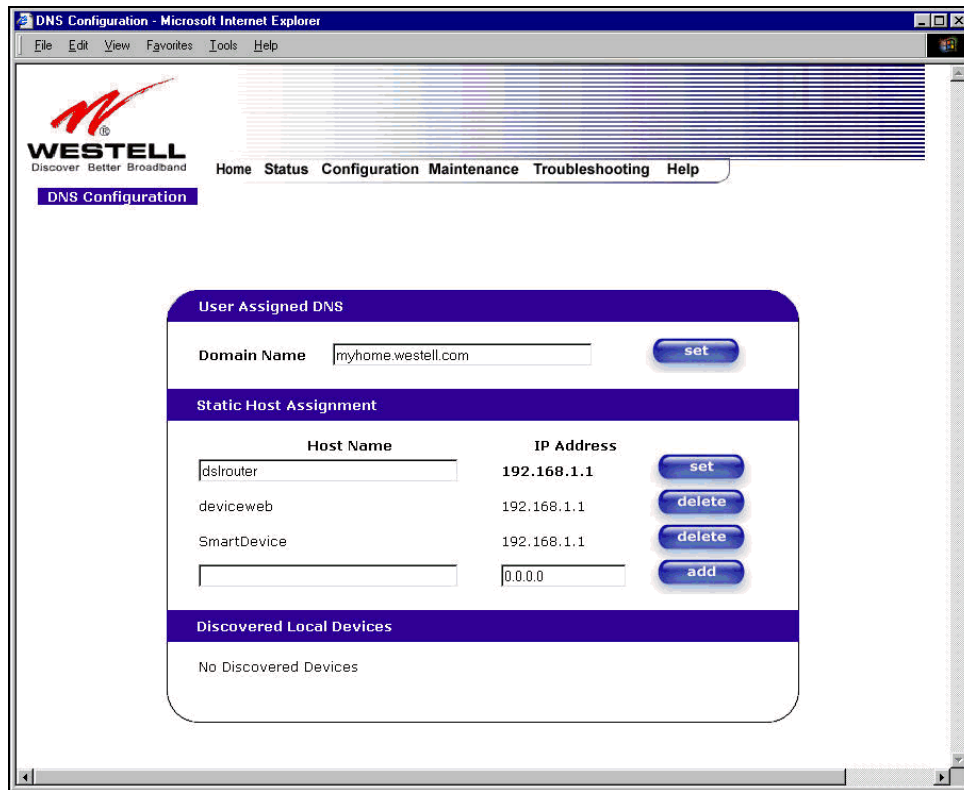

User Assigned DNS	
Domain Name	This field allows you to enter a Domain Name for VersaLink.
NOTE: Some ISP's may require the name for identification purposes.	To add a Domain Name, in the field under User Assigned DNS, type in your new domain name and click Set .
Static Host Assignment	
Host Name	This field allows you to enter a HOST name for VersaLink.
	To add a new Host name, in the field under Static Host Assignment, type in the Host Name and the IP address and click Set .
IP Address	Displays the IP address that is assigned to the Host Name.

Discover Local Devices

This field displays a list of the computers on the LAN that were assigned a DHCP Address. The DNS name and IP address entry of each discovered device is displayed. (NOTE: The values in this field will be displayed barring any propagation delays. If 'No Discovered Devices' is displayed, manually refresh the screen.)

If you want to add a new Host Name and IP address to your DNS server, enter VersaLink's **Host Name** and **IP Address** in the fields provided in the **Static Host Assignment** section.

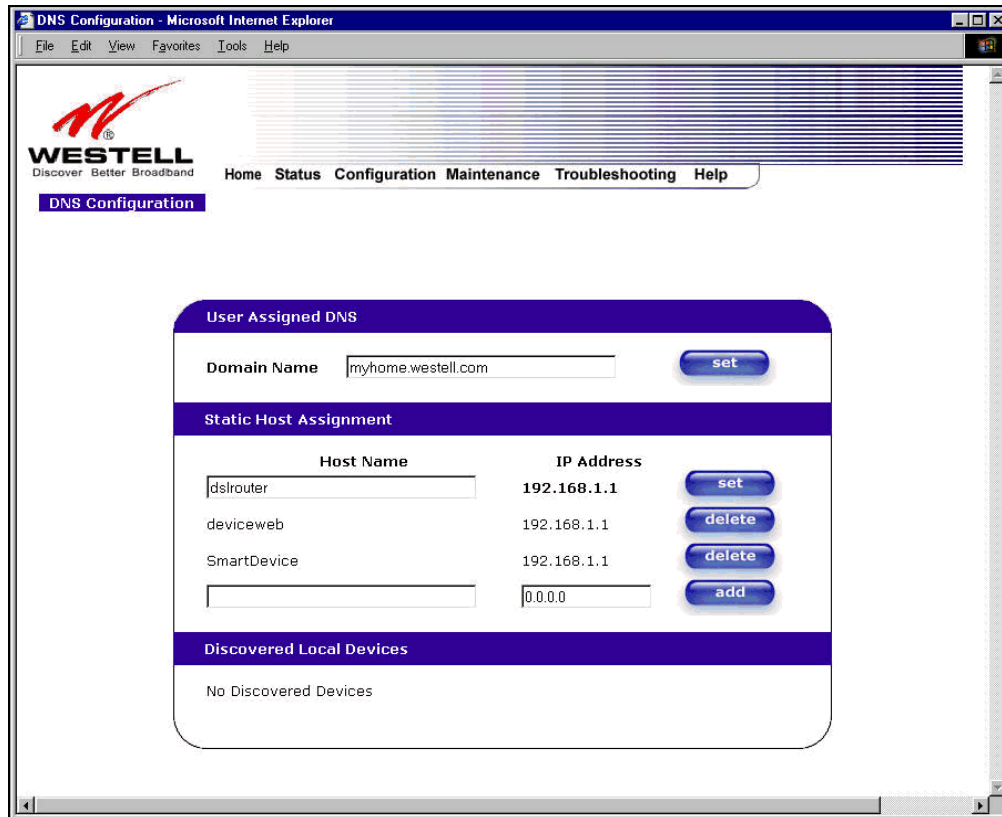

User Assigned DNS	
Domain Name	<input type="text" value="myhome.westell.com"/> <input type="button" value="set"/>

Static Host Assignment	
Host Name	IP Address
<input type="text" value="dslrouter"/>	192.168.1.1 <input type="button" value="set"/>
<input type="text" value="deviceweb"/>	192.168.1.1 <input type="button" value="delete"/>
<input type="text" value="SmartDevice"/>	192.168.1.1 <input type="button" value="delete"/>
<input type="text"/>	<input type="text" value="0.0.0.0"/> <input type="button" value="add"/>

Discovered Local Devices

No Discovered Devices

The following screen displays a **Host Name** and an **IP Address** in the fields. Now click on **add**.

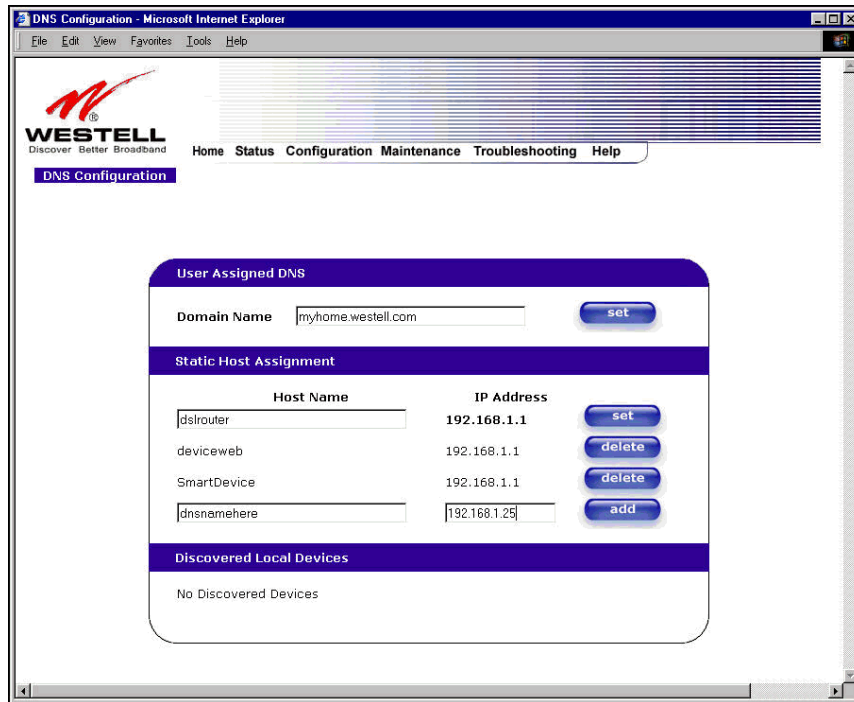

If you clicked **add**, the following screen will be displayed. The **Host Name** and **IP Address** have been added to the Static Host Assignment.

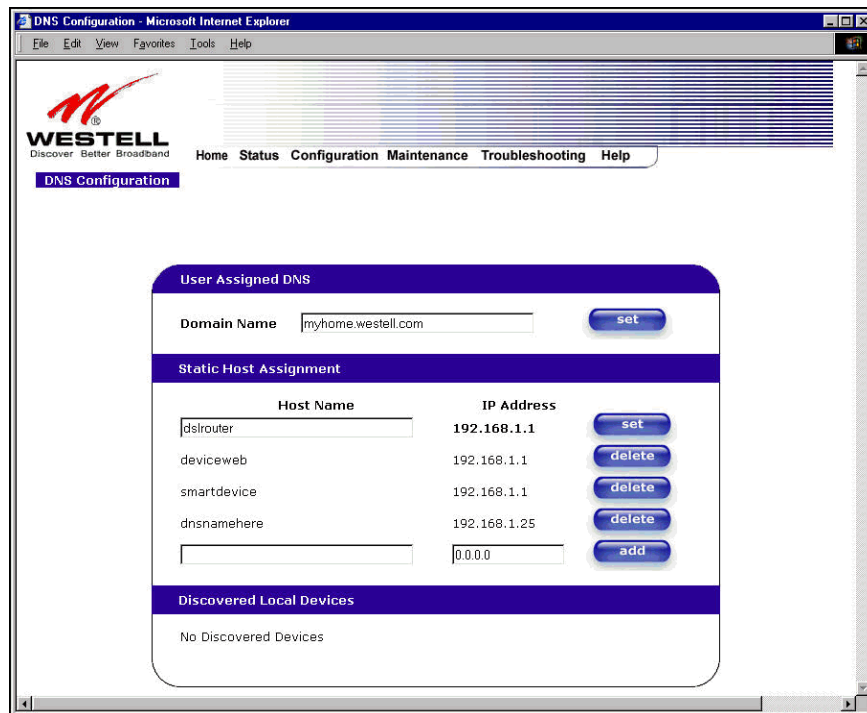

12.5.2 DHCP Configuration (Private LAN)

The following settings will be displayed if you select **DHCP** from the **Advanced LAN** menu.



DHCP Server	<p>This setting allows VersaLink to automatically assign IP addresses to local devices connected on the LAN. Westell advises setting this to enabled for the private LAN. Off = DHCP Server is disabled</p> <p>Private LAN = DHCP addresses will be saved into the Private LAN configuration. Public LAN = DHCP addresses will be saved into the Public LAN configuration. This option is only available if the Public LAN DHCP server is enabled.</p> <p>NOTE: These addresses will be overwritten if the Internet Service Provider supports dynamic setting of these values.</p>
DHCP Start Address	<p>Factory Default = 192.168.1.15</p> <p>This field displays the first IP address that the DHCP server will provide. The DHCP Start Address must be within the IP address and lower than the DHCP End Address. You may use any number from 0 to 254 in this address.</p>
DHCP End Address	<p>Factory Default = 192.168.1.47</p> <p>This field displays the last IP address that the DHCP server will provide. The DHCP End Address must be within the IP address and higher than the DHCP Start Address. You may use any number from 0 to 254 in this address.</p>
DHCP Lease Time	<p>Factory Default = 01:00:00:00</p> <p>Displays the amount of time the provided addresses will be valid, after which the DHCP client will usually re-submit a request.</p> <p>NOTE: DHCP Lease Time value must be greater than 10 seconds. Seconds must be between 0 and 59, minutes must be between 0 and 59, and hours must be between 0 and 23.</p>

12.5.3 Disabling the DHCP Server

If you click on the drop-down arrow at **DHCP Server:**, a list of options will be displayed.

If you want to disable your DHCP server, select **Off** from the **DHCP Server** drop-down arrow. Click on **save**.



If you selected **Off** at **DHCP Server:**, the following screen will be displayed. Click on **save** to save the **DHCP Server** setting.

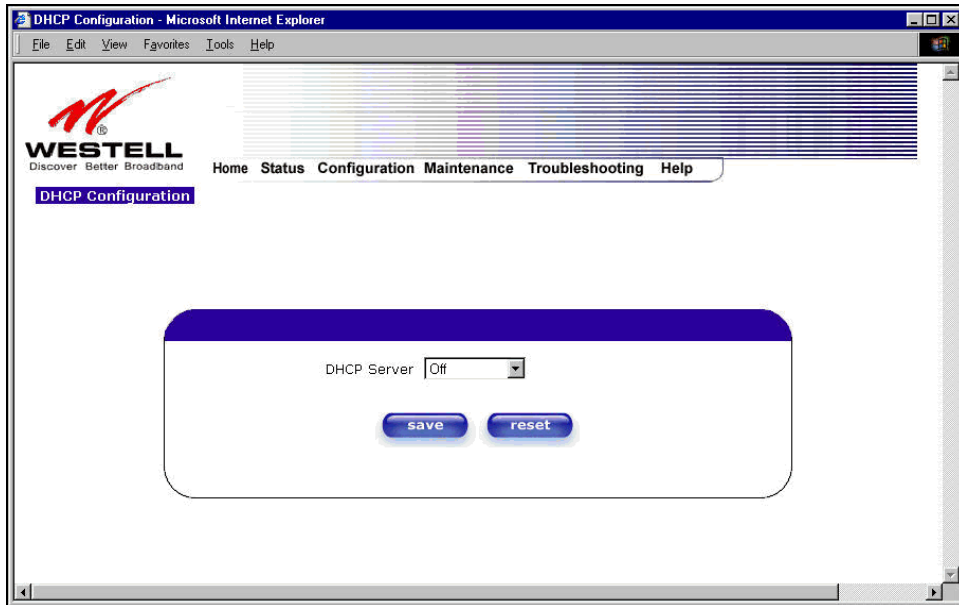

If you clicked on **save**, in the preceding **DHCP Configuration** screen, the following pop-up screen will appear. Click on **OK**.

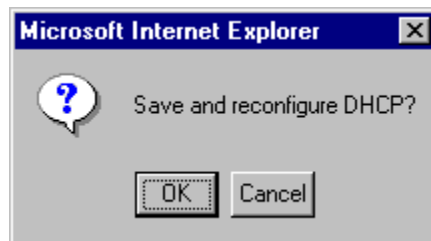

IMPORTANT: After you disable the DHCP server, you must reboot your PC.

12.5.4 Enabling the DHCP Server

If you want to enable your DHCP Server settings, select **Private LAN** at the **DHCP Server** drop-down arrow.



If you have recently disabled the DHCP Server for Private LAN, select **Private LAN** while in the following screen.

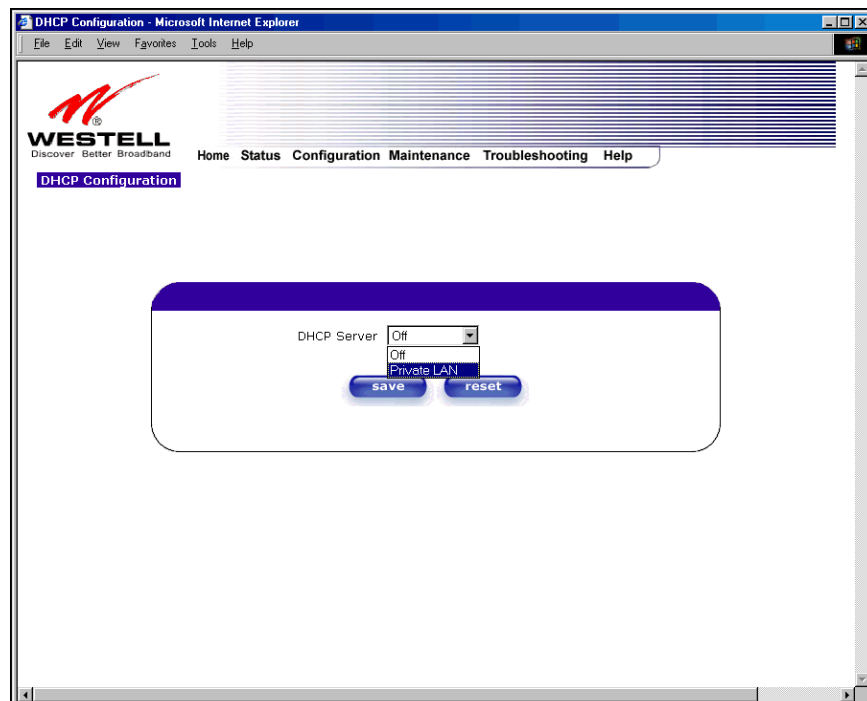

If you selected **Private LAN**, the following screen will be displayed automatically. Click on **save** to save your DHCP Server setting. If you click on **reset**, your DHCP Server will be reset to factory default. (Private LAN is the factory default for the DHCP Server.)

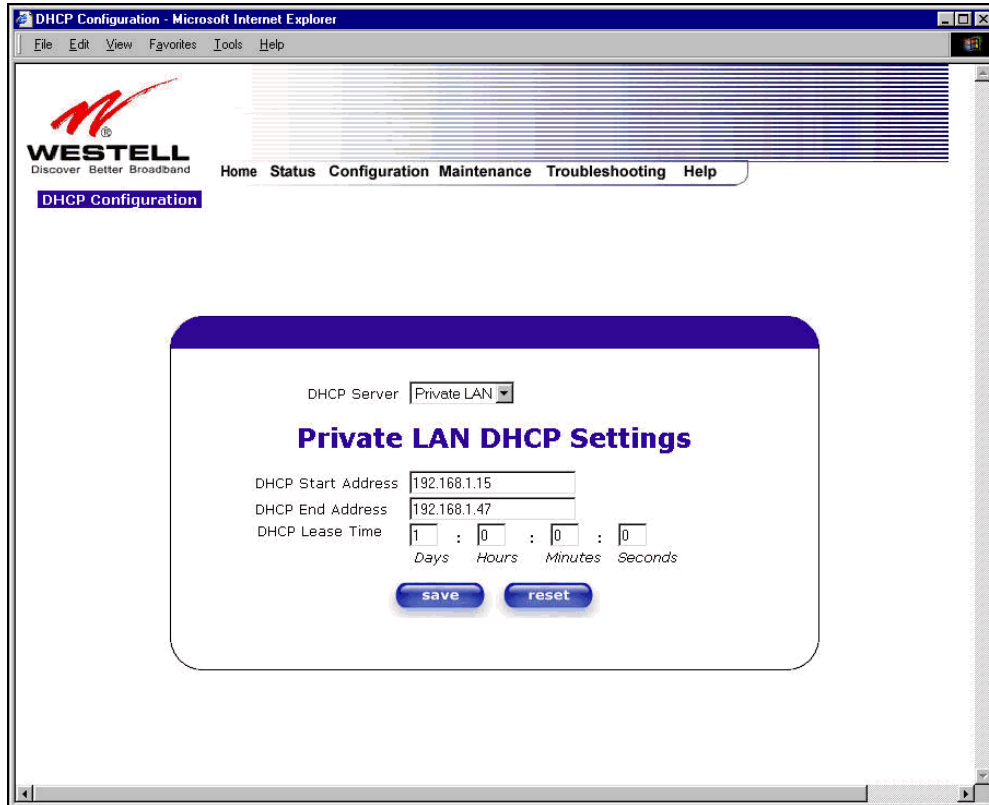

If you clicked on **save**, the following pop-up screen will appear. Click on **OK**.

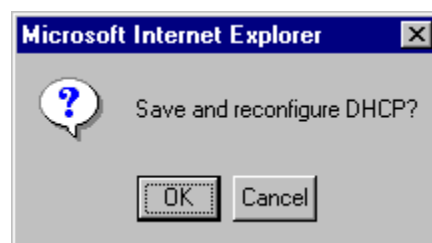

IMPORTANT: After you enable the DHCP server, you must reboot your PC.

12.5.5 Private LAN Configuration – Configuring NAT

The following settings will be displayed if you select **Private LAN** from the **Advanced LAN** menu. (Private LAN is the default configuration for this VersaLink.)

NOTE: Private LAN allows you to set up a network behind VersaLink.

If you change the settings in this screen, click **save**. If you click **reset**, the changes will not take effect.

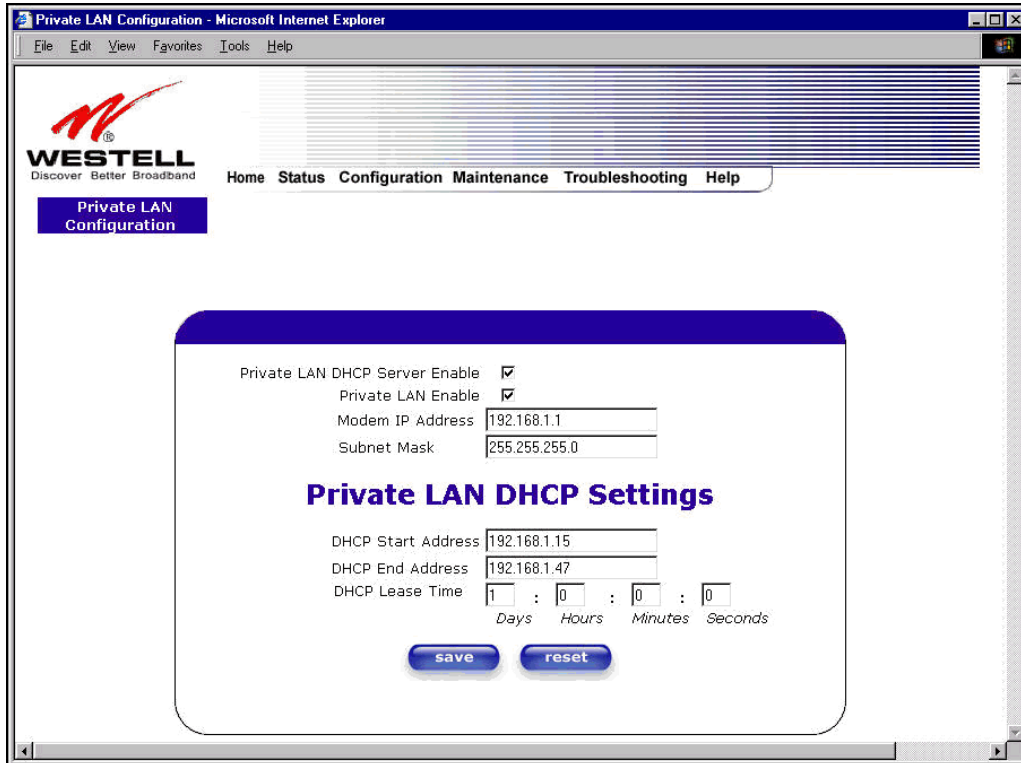

If you made changes and clicked on **save**, the following pop-up screen will be displayed. Click on **OK**. This will save your **Private LAN Configuration** settings. If you click **Cancel**, your new settings will not take effect.



Private LAN DHCP Server Enable	Default = CHECKED If this box is CHECKED, it enables DHCP addresses to be served from the Private LAN pool.
Private LAN Enable	Default = CHECKED If this box is CHECKED, it enables the addresses from the Private LAN to use the NAT interface.
Modem IP Address	Displays VersaLink's IP address

Subnet Mask	Displays the Subnet Mask, which determines what portion of an IP address is controlled by the network and which portion is controlled by the host.
DHCP Start Address	Displays the first IP address that the DHCP server will provide.
DHCP End Address	Displays the last IP address that the DHCP server will provide.
DHCP Lease Time	Displays the amount of time the provided addresses will be valid, after which the DHCP client will usually re-submit a request.

NOTE: DHCP Lease Time value must be greater than 10 seconds. The default = 01:00:00:00. Seconds must be between 0 and 59, minutes must be between 0 and 59, and hours must be between 0 and 23.

If the settings you have entered in the **Private LAN Configuration** screen are incorrect, the following warnings messages may be displayed via pop-up screens. If this occurs, check the settings in the **Private LAN Configuration** screen.

Warning Message	Check Private LAN DHCP Settings
Start Address is not part of the Subnet	Check the value in the DHCP Start Address field
End Address is not part of the Subnet	Check the value in the DHCP End Address field
End Address is below the Start Address	Check the value in the DHCP End Address field
Lease time must be greater than 10 seconds	Check the values in the DHCP Lease Time fields
Seconds must be between 0 and 59	Check the Seconds value in the DHCP Lease Time field
Minutes must be between 0 and 59	Check the Minutes value in the DHCP Lease Time field
Hours must be between 0 and 23	Check the Hours value in the DHCP Lease Time field

12.5.6 Public LAN Configuration – Multiple IP Address PassThrough

The following screen will be displayed if you select **Public LAN** from the **Advanced LAN** menu. Click in the **Public LAN DHCP Server Enable** box. A check mark will appear in the box.

NOTE: The Public LAN feature, if available from your service provider, allows VersaLink to use LAN IP addresses that are accessible from the WAN. Public LAN allows your computer to have global address ability. To utilize the Public LAN feature on VersaLink, your ISP must support Public LAN and Static IP. Contact your ISP for details.

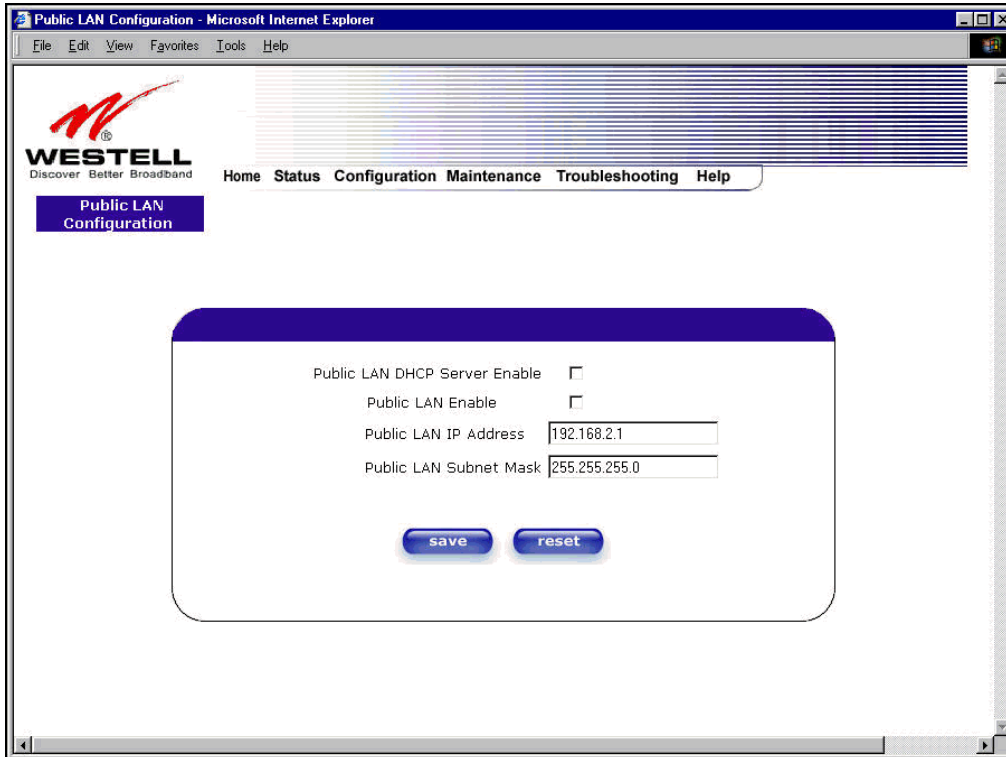

Public LAN Configuration - Microsoft Internet Explorer

File Edit View Favorites Tools Help

 WESTELL
Discover Better Broadband

Home Status Configuration Maintenance Troubleshooting Help

Public LAN Configuration

Public LAN DHCP Server Enable

Public LAN Enable

Public LAN IP Address

Public LAN Subnet Mask

save reset

Public LAN DHCP Server Enable	Default = NOT CHECKED If this box is CHECKED, it enables DHCP addresses to be served from the Public LAN pool.
Public LAN Enable	Default = NOT CHECKED If this box is CHECKED, it enables the addresses from the Public LAN to bypass the NAT interface.
Public LAN IP Address	Provides a Public IP Address if the service provider does not automatically provide one.
Public LAN Subnet Mask	Provides a Public Subnet Mask if the service provider does not automatically provide one.

If you clicked the **Public LAN DHCP Server Enable** box, the following screen will be displayed. Click on the **Public LAN Enable** box to enable Public LAN.

NOTE: By enabling the Public LAN DHCP Server, you automatically disable the Private LAN DHCP Server on VersaLink.

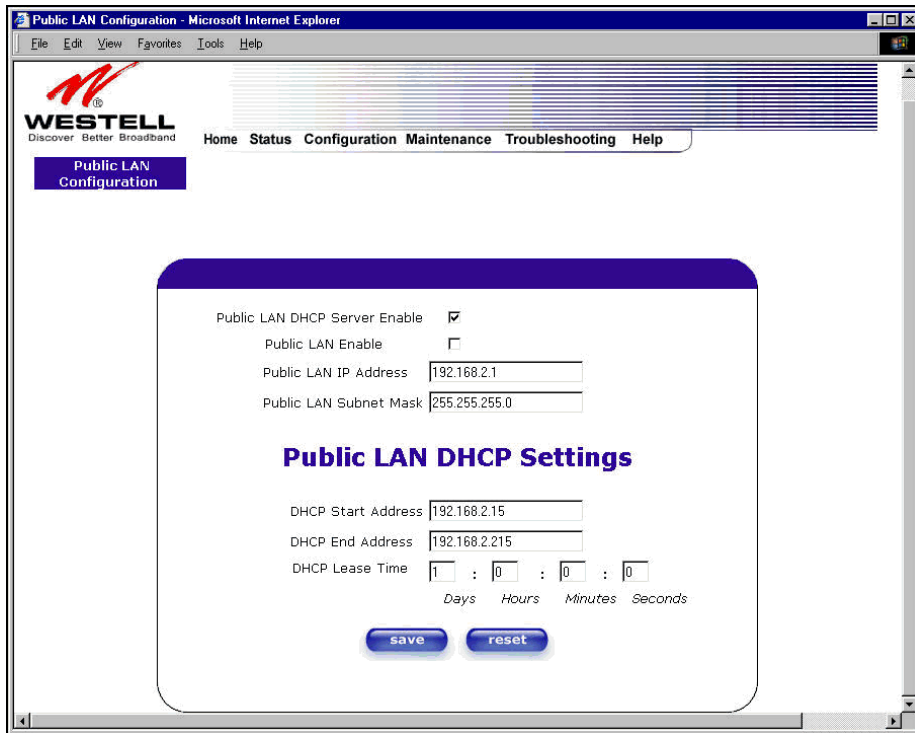

If you clicked the **Public LAN Enable** box, the following screen will be displayed, showing the Public LAN Enable box selected. Click on **save**.

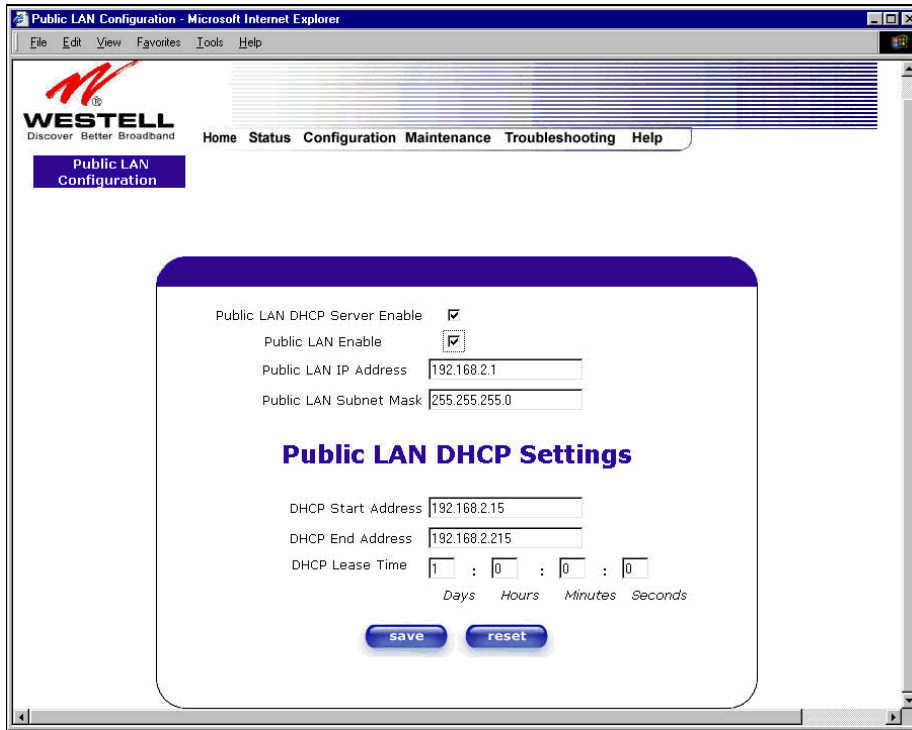

If you selected **Public LAN Enable**, or if you made other changes in the **Public LAN Configuration** screen and clicked **save**, the following pop-up screen will be displayed. Click **OK** to save the new settings. If you click on **Cancel**, your new settings will not take effect.



NOTE: DHCP Lease Time value must be greater than 10 seconds. The default = 01:00:00:00. Seconds must be between 0 and 59, minutes must be between 0 and 59, and hours must be between 0 and 23.

If the settings you have entered in the **Public LAN Configuration** screen are incorrect, the following warnings messages may be displayed via pop-up screens. If this occurs, check settings in the **Public LAN Configuration** screen.

Warning Message	Check Public LAN DHCP Settings
Start Address is not part of the Subnet	Check the value in the DHCP Start Address field
End Address is not part of the Subnet	Check the value in the DHCP End Address field
End Address is below the Start Address	Check the value in the DHCP End Address field
Lease time must be greater than 10 seconds	Check the values in the DHCP Lease Time fields

Seconds must be between 0 and 59	Check the Seconds field at DHCP Lease Time
Minutes must be between 0 and 59	Check the Minutes field at DHCP Lease Time
Hours must be between 0 and 23	Check the Hours field at DHCP Lease Time

If you clicked on **OK** in the **Load new Public LAN configuration?** screen, the following pop-up screen will be displayed. This will allow the modem to be reset and the new configuration will take effect. Click on **OK**.

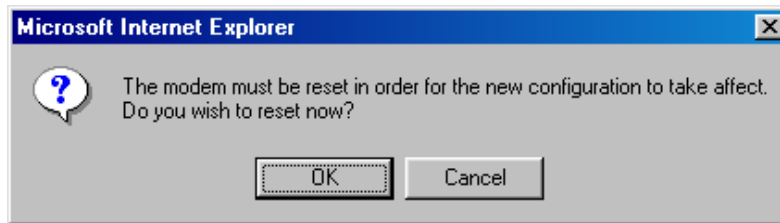

If you clicked on **OK** in the preceding screen, the following screen will be displayed. VersaLink will be reset and the new configuration will take effect.

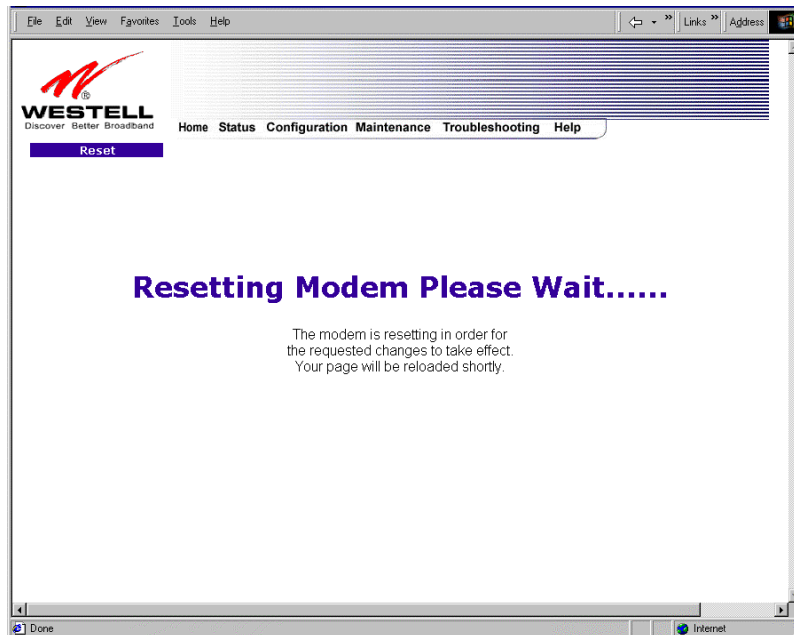

After a brief delay, the home page will be displayed. Confirm that you have a DSL sync and that your PPP session displays **UP**. (Click on the **connect** button to establish a PPP session).

NOTE: Whenever the PPP Status displays **DOWN**, you do not have a PPP session established. If your Gateway's connection setting is set to "Always On," after a brief delay the PPP session will be established automatically and the PPP Status will display **UP**. If the connection setting is set to "Manual," you must click on the **Connect** button to establish a PPP session. Once the PPP session has been established (PPP Status displays **UP**), you may proceed with your Gateway's configuration.

12.5.7 VLAN

The following settings will be displayed if you select **VLAN** from the **Advanced LAN** menu.

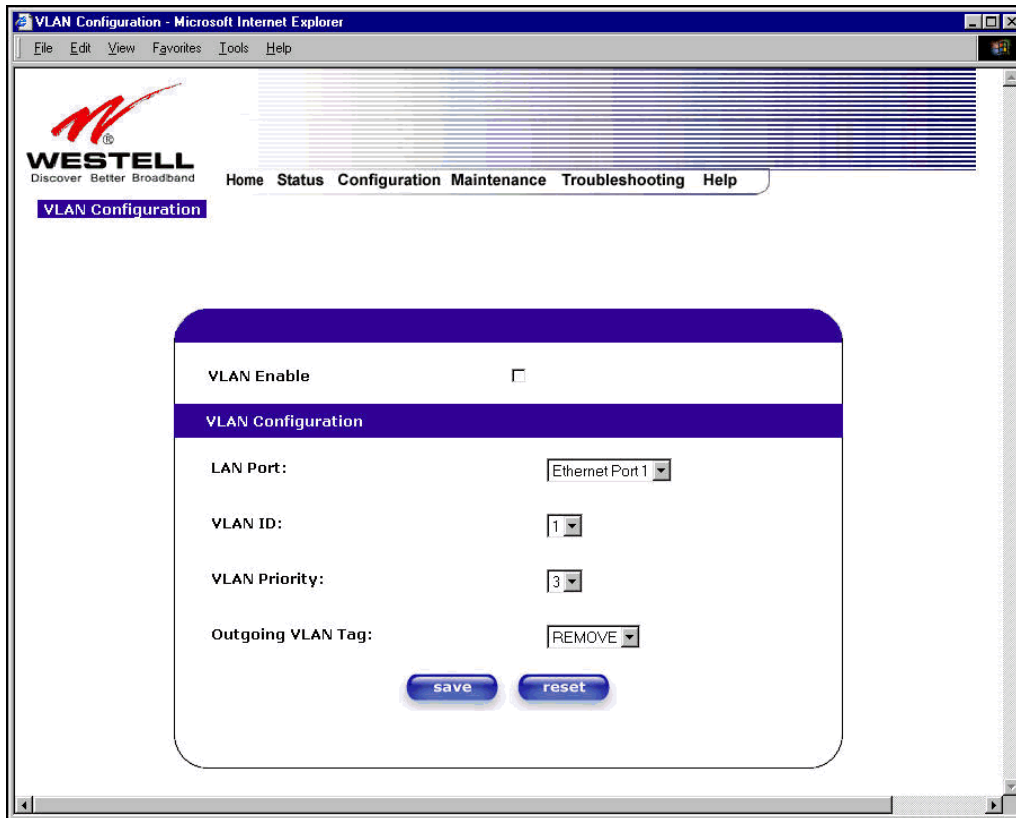

VLAN Enable	Factory Default = DISABLED If this box is check, VLAN will be Enabled. This will allow VLAN tagging to occur according to the data port's configuration.
LAN Port	This allows you to select the LAN port that you wish to configure. Possible responses are: Ethernet Port 1 Ethernet Port 2 Ethernet Port 3 Ethernet Port 4 WLAN Port
VLAN ID	This allows you to assign a VLAN ID to the port. Possible responses are: 1 through 8
VLAN Priority	This allows you to set the VLAN priority for the port. Possible responses are: 0 through 7
Outgoing VLAN Tag	This allows you to keep or remove the VLAN tag on the port when data is outgoing.

To enable VLAN, click on the box adjacent to the **VLAN Enable** field. A check mark will appear in the box. Click on **save**.

NOTE: For VLAN to function properly, the VLAN ID must be set to a value other than '1' in **VLAN Configuration** screen and in the **VC 1 Configuration** screen when you are using the Bridge (VLAN Bridge) protocol. See Advanced WAN section for configuring VC's (refer to section 12.6.5).

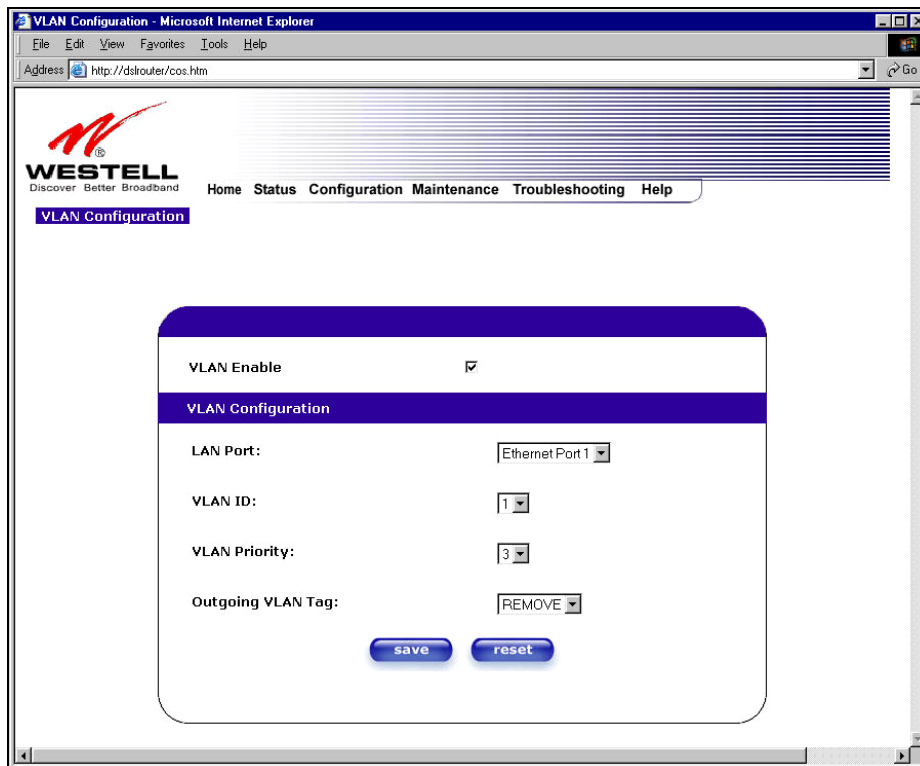

NOTE: If you change the values in the **VLAN Configuration** screen and click the **reset** button, the screen will display the previously set values for the LAN Port you have selected. If you change the settings in this screen, you must click **save** to save the new settings.

If you click on **save**, the following pop-up screen will appear. Click **OK** in the pop-up screen to allow the new settings to take effect.

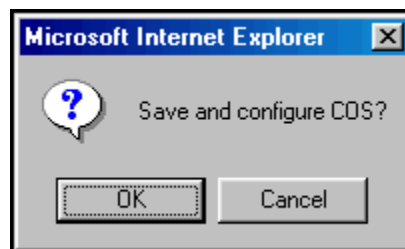

12.6 Advanced WAN

This section explains the configurable features of VersaLink that are available if you select **Advanced WAN** from the **Configuration** menu.

NOTE: If VersaLink is configured for **ETHERNET PORT 1**, **QOS** will not be displayed. You must configure VersaLink for **DSL/ATM PORT** to access **QOS** in the **Advanced WAN** drop-down menu. Refer to section 12.6.2.1 for details.

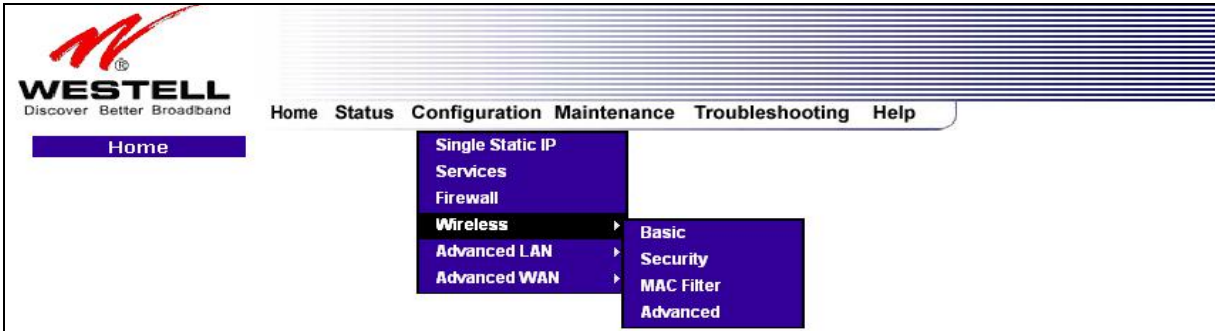

12.6.1 ATM Loopbacks

If you select **ATM Loopbacks** from the **Configuration** menu, the following settings will be displayed.

NOTE: When the **Enable ATM 0/21** box is checked, this feature is enabled. If the box does not display a check mark, this feature is disabled. If you change the setting in this screen, you must click on **save**. **Westell does not recommend that you change this setting.**

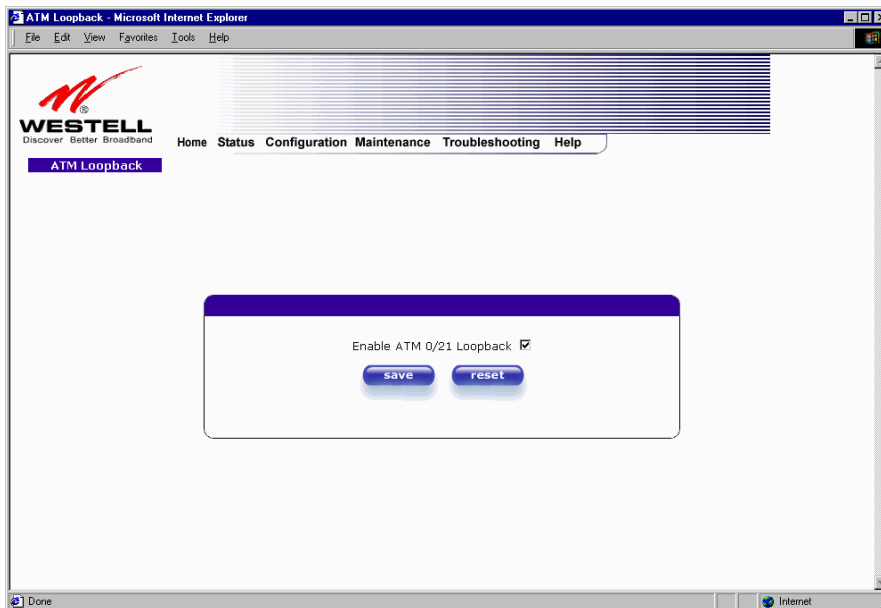

Enable ATM 0/21 Loopback:

Factory Default = ENABLED

This option enables the 0/21 loopback, which is used by your ISP.
NOTE: Westell does not recommend that you change this setting.

12.6.2 WAN Configuration

The following settings will be displayed if you select **WAN** from the **Advanced WAN** menu. If you change the **Bridge Broadcast**, **Bridge Multicast**, or **Spanning Tree Protocol** configurations in this screen, click on the **save filter settings** button to allow these changes to take effect. If you change any of the **Status** configurations, a pop-up screen will prompt you to reset the Gateway. After the Gateway has been reset, the **Status** configurations will take effect. The **edit** button allows you to change the VC configuration settings of the Gateway. Details on the **edit** button are explained later in section 12.6.3.

NOTE: The actual information displayed in this screen may vary, depending on the network connection established.

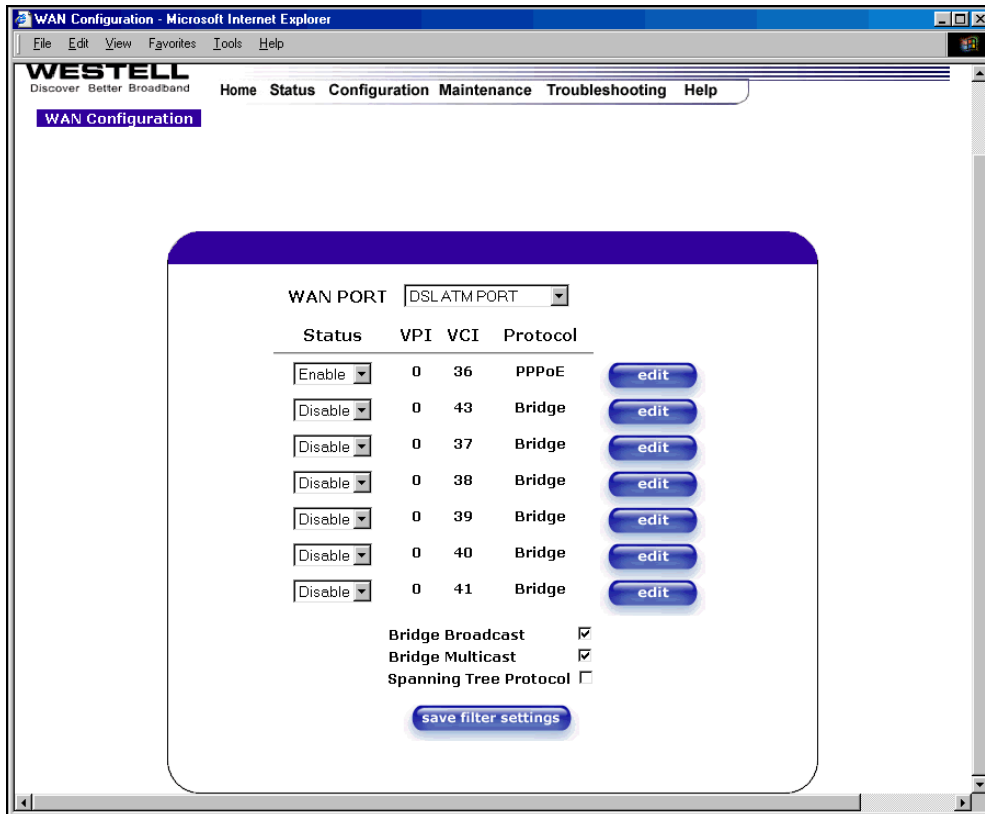

WAN PORT	<p>Factory Default = DSLATM PORT</p> <p>Possible Responses: DSLATM PORT ETHERNET PORT 1</p>
Status	Allows you to enable or disable your VC (Virtual Connection)
VPI	Displays the VPI (Virtual Path Indicator) value for a particular VC, which is defined by your Service Provider.
VCI	Displays the VCI (Virtual Channel Indicator) value for a particular VC, which is defined by your Service Provider.
Protocol	<p>Displays the Protocol for each VC, which is specified by your Service Provider.</p> <p>Possible Response: PPPoA = Point to Point Protocol over ATM (Asynchronous Transfer Mode) PPPoE = Point to Point Protocol over Ethernet Bridge = Bridge Protocol Classical IPoA = Internet Protocol over ATM (Asynchronous Transfer Mode). This is an ATM encapsulation of the IP protocol.</p>
Bridge Broadcast	<p>Factory Default = CHECKED</p> <p>When this setting is CHECKED, VersaLink will allow Broadcast IP packets to/from the WAN.</p> <p>When this setting is NOT CHECKED, VersaLink will block Broadcast IP packets to/from the WAN.</p> <p>This setting is only valid if one of the Virtual Channels is configured for Bridge mode.</p>
Bridge Multicast	<p>Factory Default = CHECKED</p> <p>When this setting is CHECKED, VersaLink will allow Multicast IP packets to/from the WAN.</p> <p>When this setting is NOT CHECKED, VersaLink will block Multicast IP packets to/from the WAN.</p> <p>This setting is only valid if one of the Virtual Channels is configured for Bridge mode.</p>
Spanning Tree Protocol	<p>Factory Default = DISABLED</p> <p>Spanning Tree Protocol is a link management protocol that provides path redundancy while preventing undesirable loops in the network. For Ethernet network to function properly, only one active path can exist between two stations.</p> <p>When ENABLED, two bridges are used to interconnect the same two computer network segments. Spanning Tree Protocol will allow the bridges to exchange information so that only one of them will handle a given message that is being sent between two computers within the network.</p> <p>NOTE: Spanning Tree can't be enabled if VLAN is enabled.</p>

12.6.2.1 Enabling DSLATM PORT – Disabling ETHERNET PORT 1 (If Applicable)

NOTE: When using the optional uplink port (E1), Ethernet LAN connection is limited to E2, E3, and E4. The UPLINK feature is optional. If UPLINK is not enabled, VersaLink will use DSL and wireless only.

To configure the VersaLink so that it uses the DSL port, select **DSLATM PORT** from the **WAN PORT** drop-down arrow. By selecting **DSLATM PORT**, you will enable the VersaLink's DSL transceiver. This will disable the WAN Ethernet port and allow the WAN interface to use the DSL port.

NOTE: All of VersaLink's menu options are displayed if VersaLink is configured for **DSLATM PORT**.

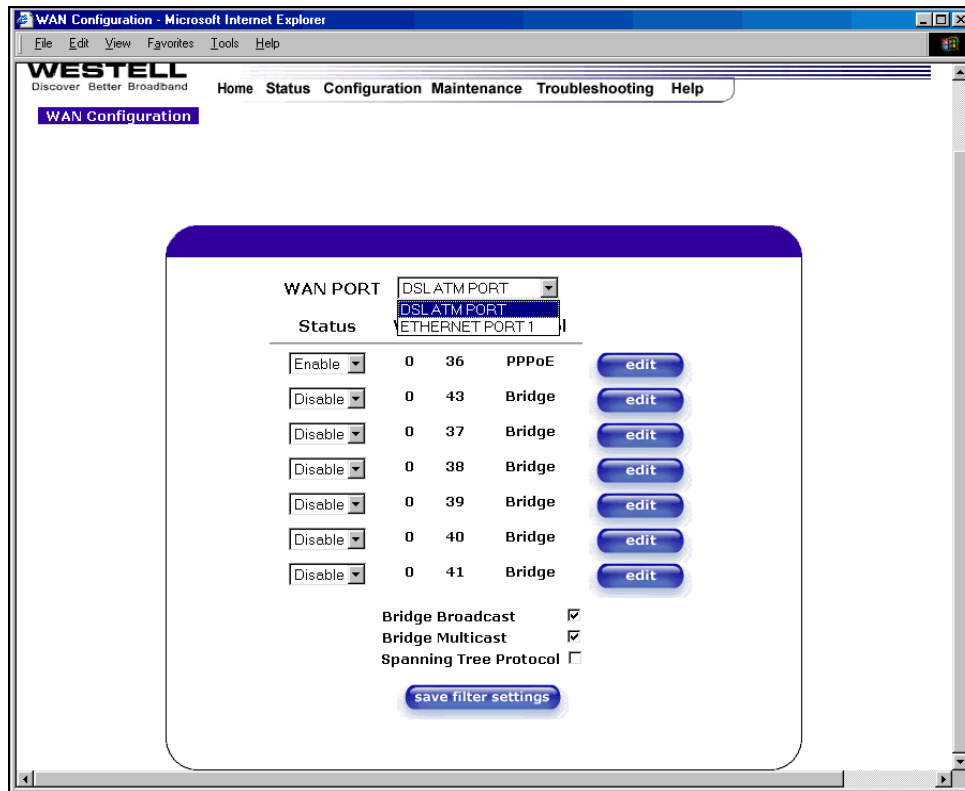

If you select **DSLATM PORT** from the **WAN Port** drop-down arrow, the following screen will be displayed. Click **OK**.

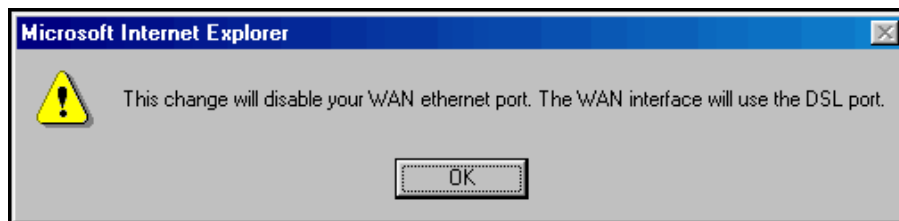

If you click **OK** in the preceding pop-up screen, the following screen will be displayed. Click on **OK**. If you click on **Cancel**, the change will not take effect.

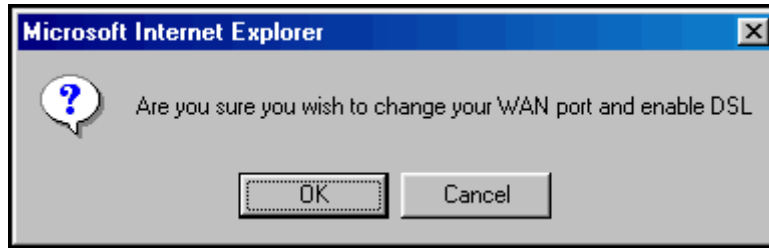

If you clicked on **OK** in the preceding pop-up screen, the following pop-up screen will appear. VersaLink must be reset to allow the new configuration to take effect. Click on **OK**.

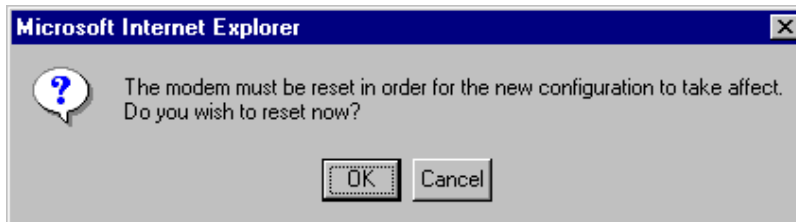

If you clicked on **OK** in the preceding screen, the following screen will be displayed. VersaLink will be reset and the new configuration will take effect.

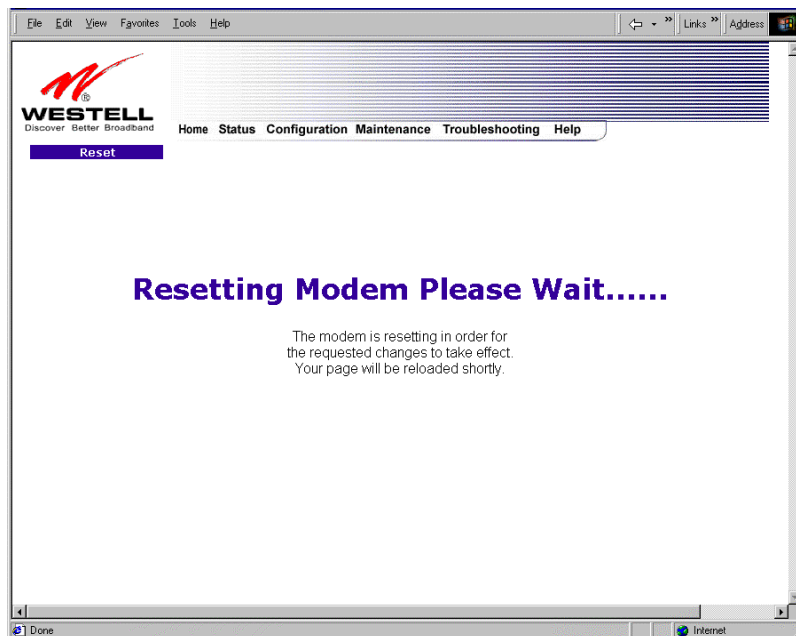

After a brief delay, the home page will be displayed. Confirm that you have a DSL sync and that your PPP session displays **UP**. (Click on the **connect** button to establish a PPP session).

12.6.2.2 Disabling DSLATM PORT – Enabling ETHERNET PORT 1

To configure the VersaLink so that it uses the WAN Ethernet Port, select **ETHERNET PORT 1** from the **WAN PORT** drop-down arrow. By selecting **ETHERNET PORT 1**, you will disable the VersaLink’s DSL transceiver. This will disable the DSL Port and allow the WAN interface to use the WAN Ethernet Port.

NOTE: If ETHERNET PORT 1 is configured, the VersaLink’s menu options may or may not be displayed. The sections explained throughout this document will indicate when a menu item is unavailable. The UPLINK feature is optional, and if UPLINK is not enabled in the .ini file, the Gateway will use DSL and Wireless only.

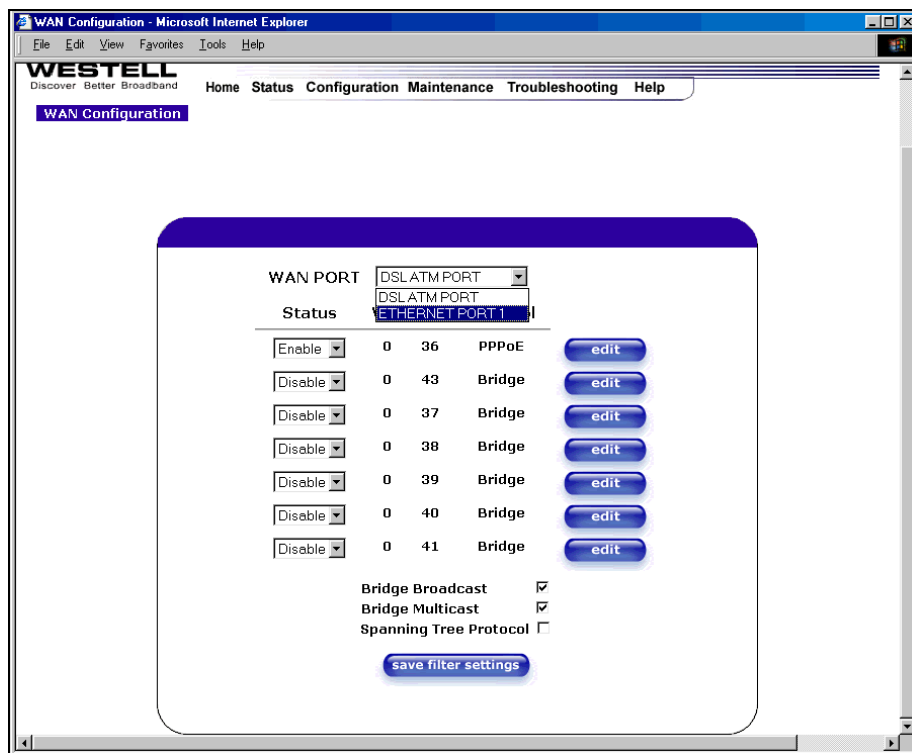

NOTE: If you experience any problems, please reset VersaLink via the external hardware reset button or via the procedure defined under the **Maintenance** menu in section 14.1. (Factory defaults become current configuration.)

If you select **ETHERNET PORT 1** from the **WAN Port** drop-down arrow, the following screen will be displayed. Click **OK**.

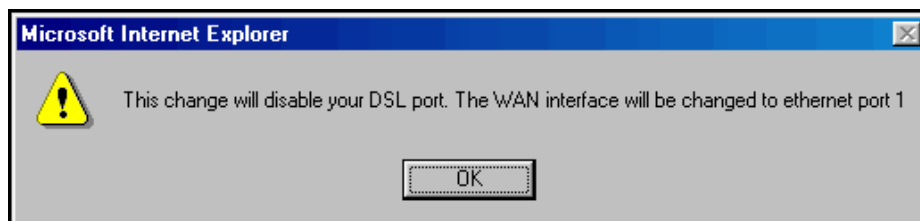

If you click on **OK** in the preceding pop-up screen, the following screen will be displayed. Click on **OK**. If you click on **Cancel**, the change will not take effect.

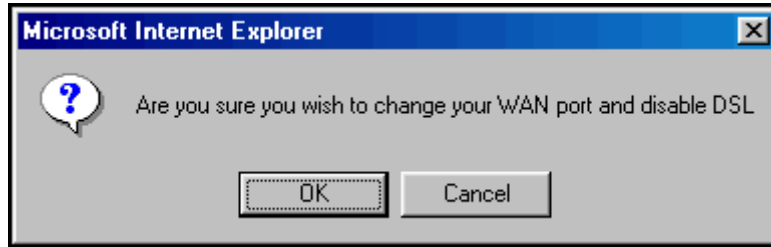

If you clicked on **OK** in the preceding pop-up screen, the following pop-up screen will appear. VersaLink must be reset to allow the new configuration to take effect. Click on **OK**.

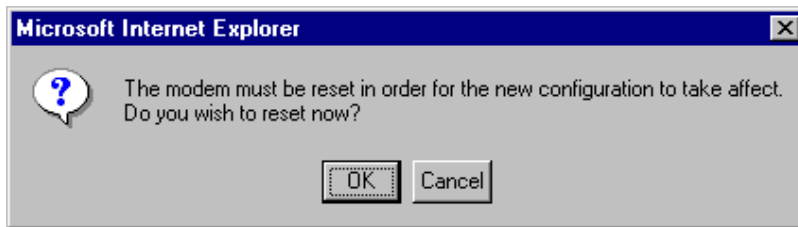

If you clicked on **OK** in the preceding screen, the following screen will be displayed. VersaLink will be reset and the new configuration will take effect.

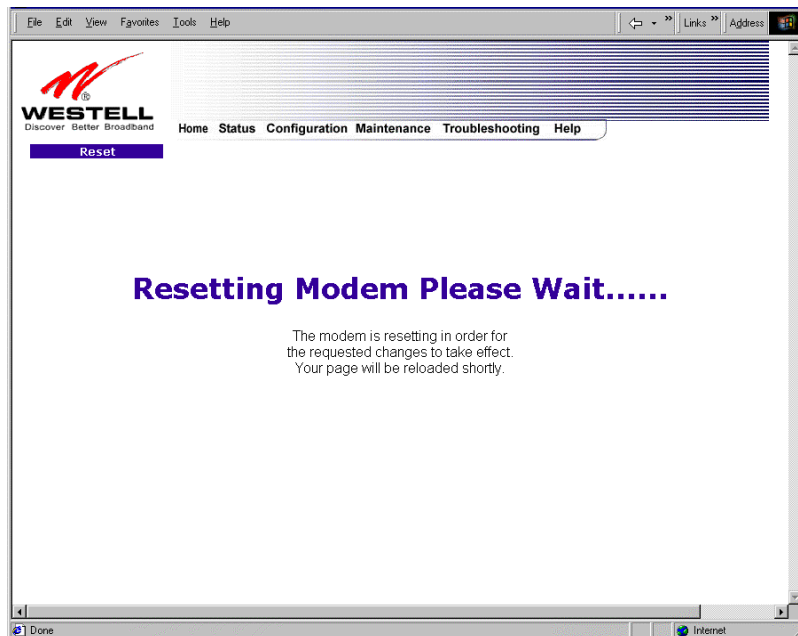

After VersaLink has been reset, the DSL LED will be OFF. This is because the DSL transceiver has now been disabled. However, the **Power**, **Ethernet**, and **Wireless** LEDs will remain lit.

12.6.3 Editing the WAN Configuration

The following **VC 1 Configuration** screen will be displayed if you click on the **edit** button adjacent to any of the 'Enabled' protocols displayed in the **WAN Configuration** screen. (NOTE: The Protocol must be enabled before you can edit its VC configuration.) The **VC 1 Configuration** screen allows you to edit your virtual connection (VC). A virtual connection identifies a connection through the service provider's ATM network to your ISP. Unlike physical hardware connections, virtual connections are defined by data.

If you change any of the VC settings in the following screen, click on the **Set VC** button.

NOTE: If you experience any problems, please reset VersaLink via the external hardware reset button or via the procedure defined under the **Maintenance** menu in section 14.1. The actual information displayed in this screen may vary, depending on network connection established.

VC 1 Configuration

VPI

VCI

PCR

QoS

Protocol

Status Enabled

VC 1 - PPPoE Settings

IP Address

Gateway

DNS Primary

DNS Secondary

MRU Negotiation

LCP Echo Disable

LCP Echo Failures
"Must be between 1 and 30 inclusive."

LCP Echo Duration
*"Must be between 5 and 300 seconds inclusive
and greater or equal to Retry Duration."*

LCP Echo Retry Duration
"Must be between 5 and 300 seconds inclusive."

Tunneling Enable Disable

[Help](#)

VC 1 Configuration	
VPI	This setting allows you to change your VPI (Virtual Path Indicator) value for a particular VC, which is defined by your Service Provider.
VCI	This setting allows you to change your VCI (Virtual Channel Indicator) value for a particular VC, which is defined by your Service Provider.
PCR	<p>Factory Default = 100%</p> <p>Peak Cell Rate (PCR)-The maximum rate at which cells can be transmitted across a virtual circuit, specified in cells per second and defined by the interval between the transmission of the last bit of one cell and the first bit of the next.</p> <p>This value is a percentage of the current data rate. 100 allows this VC to use 100% of the available bandwidth. 80 allows this VC to use 80% of the available bandwidth.</p>
QoS	<p>Quality of Service, which is determined by your Service Provider.</p> <p>Possible Responses: CBR = Constant Bit Rate UBR = Unspecified Bit Rate VBR = Variable Bit Rate</p>
Protocol	<p>The Protocol for each VC, which is specified by your Service Provider.</p> <p>Possible Responses: PPPoA = Point to Point Protocol over ATM (Asynchronous Transfer Mode) PPPoE = Point to Point Protocol over Ethernet Bridge = Bridge Protocol Classical IPoA = Internet Protocol over ATM (Asynchronous Transfer Mode). This is an ATM encapsulation of the IP protocol.</p>
Status	The protocol status.
VC x PPPoE Settings	
IP Address	Displays the IP network address that your modem is on.
VersaLink	Displays VersaLink IP VersaLink address
DNS Primary	Provided by your Service Provider
DNS Secondary	Provided by your Service Provider
MRU Negotiation	<p>Factory Default = DISABLED</p> <p>If ENABLED, the Maximum Received Unit (MRU) would enforce MRU negotiations. (NOTE: enable this option only at your Internet Service Provider's request.)</p>
LCP Echo Disable	<p>Factory Default = Enable</p> <p>If checked, this option will disable the modem LCP Echo transmissions.</p>
LCP Echo Failures	Indicates number of continuous LCP echo non-responses received before the PPP session is terminated.
LCP Echo Retry Duration	The interval between LCP Echo transmissions with responses.
LCP Echo Retry Duration	The interval between LCP Echo after no response.
Tunneling	<p>Factory Default = ENABLE</p> <p>If ENABLED, this option allows PPP traffic to be bridged to the WAN. This feature allows you to use a PPPoE shim on the host computer to connect to the Internet service provider, by bypassing VersaLink's capability to do this.</p> <p>NOTE: Tunneling is available in PPPoE mode only.</p>

NOTE: The values for IP Address, VersaLink, DNS Primary, and DNS Secondary are all "Override of the values obtained from the PPP connection," They default to "0.0.0.0," in which case the override is ignored. Westell recommends that you do not change the values unless your Internet Service Provider instructs you to change them.

If you have made any changes to your VC settings, you need to save them. To save the new VC settings, click on **OK** when asked **Set this PPPoE VC configuration?** If you click on **cancel**, the new VC settings will not be saved.



If you clicked on **OK** in the preceding pop-up screen, the following pop-up screen will appear. VersaLink must be reset to allow the new configuration to take effect. Click **OK**.

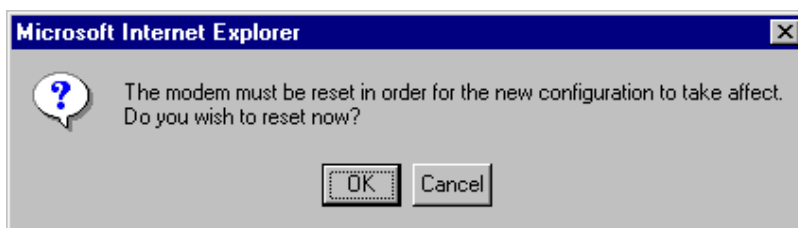

If you clicked **OK** in the preceding screen, the following screen will be displayed. VersaLink will be reset and the new configuration will take effect.

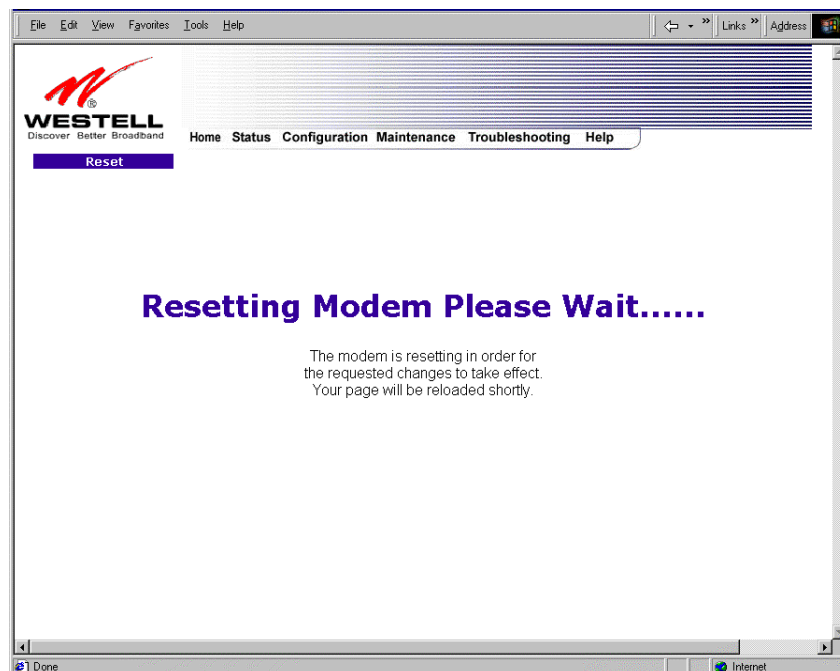

After a brief delay, the home page will be displayed. Confirm that you have a DSL sync and that your PPP session displays **UP**. (Click on the **connect** button to establish a PPP session).

12.6.4 Configuring VersaLink's Protocol Settings for PPPoE Mode

To configure VersaLink's protocol settings for PPPoE mode, select **WAN** from the **Advanced WAN** menu. The **WAN Configuration** screen will be displayed. Next, click on the **edit** button adjacent to any of the existing 'Enabled' VC (Virtual Connection) protocols.

NOTE: The protocol status must display "Enable" to allow edits to its VC configuration.

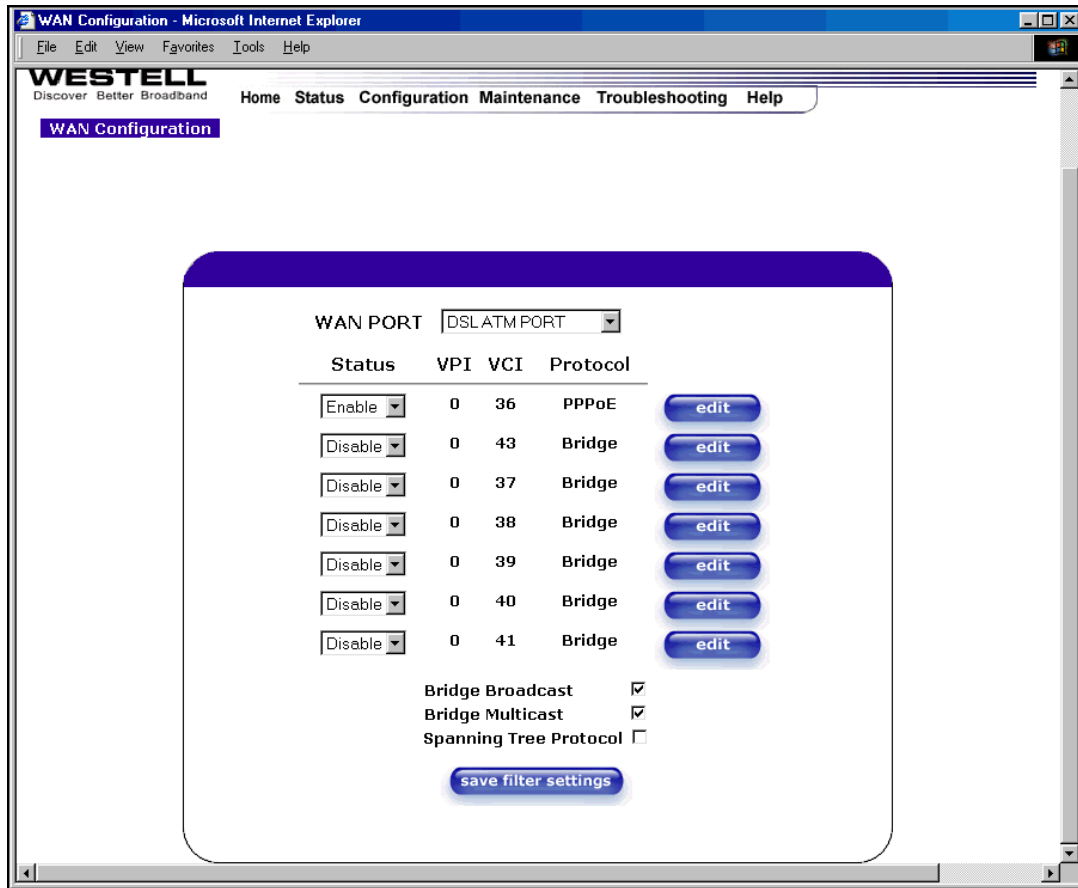

If you clicked **edit** in the **WAN Configuration** screen, the following **VC 1 Configuration** screen will be displayed. Select **PPPoE** from the options listed in **Protocol** drop-down arrow. After you have made the configuration for this protocol, select the **set VC** button.

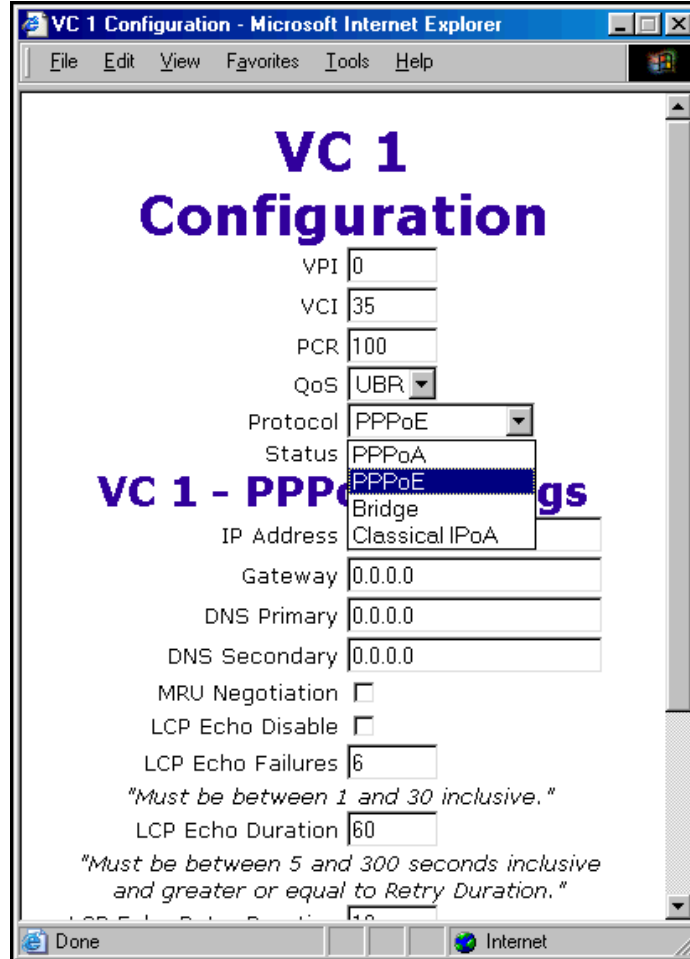

VC 1 Configuration

VPI

VCI

PCR

QoS

Protocol

Status

VC 1 - PPPoE

IP Address

Gateway

DNS Primary

DNS Secondary

MRU Negotiation

LCP Echo Disable

LCP Echo Failures
"Must be between 1 and 30 inclusive."

LCP Echo Duration
"Must be between 5 and 300 seconds inclusive and greater or equal to Retry Duration."

If you click the **set VC** button, the following pop-up screen will be displayed. Click on **OK** in the pop-up screen. If you click on **Cancel**, the new settings will not be saved. After you click on **OK**, follow the instructions to reset the Gateway, as previously discussed in section 12.6.3.



12.6.5 Configuring VersaLink's Protocol Settings for Bridge Mode

To configure VersaLink's protocol settings for **Bridge** mode, select **WAN** from the **Advanced WAN** menu. The **WAN Configuration** screen will be displayed. Next, click on the **edit** button adjacent to any of the existing 'Enabled' VC (Virtual Connection) protocols. The **VC1 Configuration** screen will be displayed.

NOTE: The protocol status must display "Enable" to allow edits to its VC configuration.

If you select **Bridge** protocol from the **Protocol** drop-down arrow, the following screen will be displayed. Select a mode from the options listed in the **Mode** drop-down arrow, under **VC 1 – Bridge Settings**.

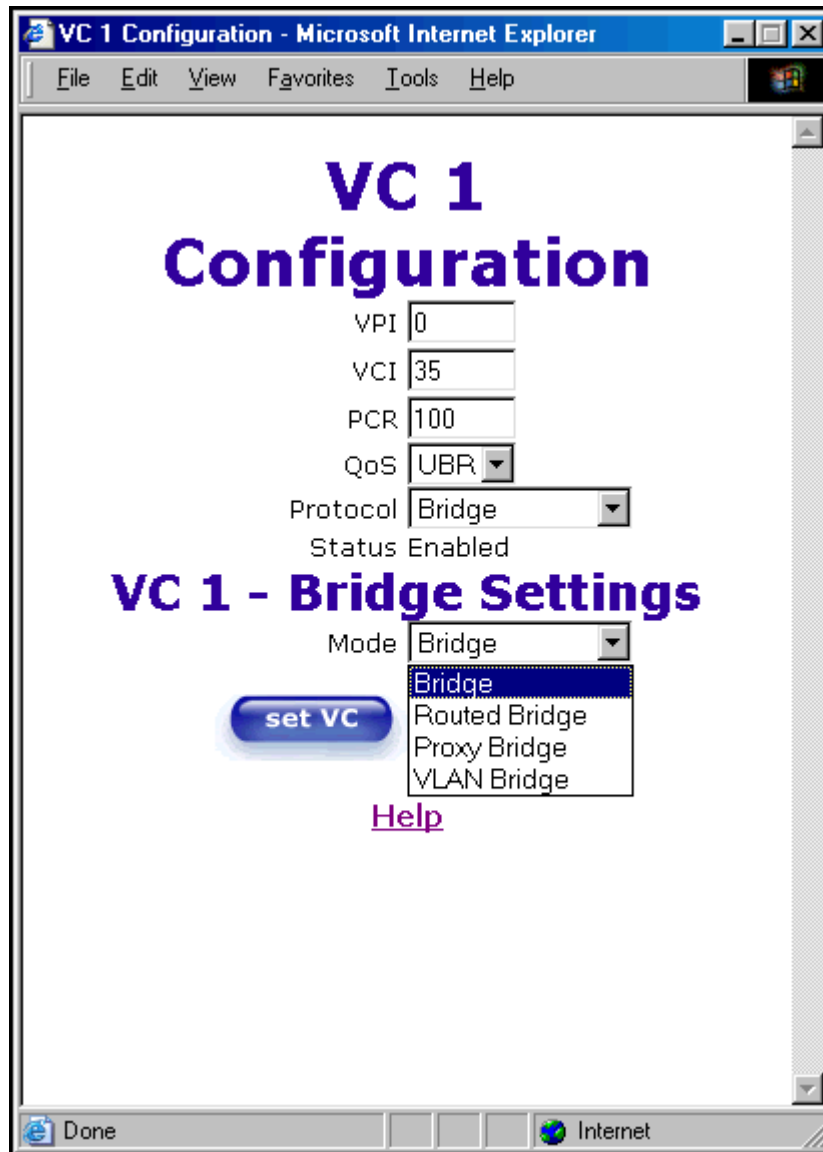

VC 1 Configuration	
VPI	This setting allows you to change your VPI (Virtual Path Indicator) value for a particular VC, which is defined by your Service Provider.
VCI	This setting allows you to change your VCI (Virtual Channel Indicator) value for a particular VC, which is defined by your Service Provider.
PCR	<p>Factory Default = 100%</p> <p>Peak Cell Rate (PCR)-The maximum rate at which cells can be transmitted across a virtual circuit, specified in cells per second and defined by the interval between the transmission of the last bit of one cell and the first bit of the next.</p> <p>This value is a percentage of the current data rate. 100 allows this VC to use 100% of the available bandwidth. 80 allows this VC to use 80% of the available bandwidth.</p>
QoS	<p>Quality of Service, which is determined by your Service Provider.</p> <p>CBR = Constant Bit Rate UBR = Unspecified Bit Rate VBR = Variable Bit Rate</p>
Protocol	<p>The Protocol for each VC, which is specified by your Service Provider.</p> <p>PPPoA = Point to Point Protocol over ATM (Asynchronous Transfer Mode) PPPoE = Point to Point Protocol over Ethernet Bridge = Bridge Protocol Classical IPoA = Internet Protocol over ATM (Asynchronous Transfer Mode). This is an ATM encapsulation of the IP protocol.</p>
Status	The protocol status.
VC 1 Bridge Settings	
Mode	<p>Bridge = A bridge is a layer 2 device that connects two segments of the same LAN that use the same protocol such as Ethernet. The modem does not have a WAN IP address in this mode. The client PC will typically get an IP address from a DHCP server in the network or the IP address can be assigned to the client PC statically.</p>
	<p>Routed Bridge = Routed Bridged Encapsulation (RBE) is the process by which a bridged segment is terminated on a routed interface. Specifically, VersaLink is routing on an IEEE 802.3 or Ethernet header carried over RFC 1483 bridged ATM. RBE was developed to address the known RFC1483 bridging issues, including broadcast storms and security. The modem will get a WAN IP address through DHCP or can be assigned statically. NAT will use the global address assigned to the modem.</p>
	<p>Proxy Bridge = Proxy Bridge is the process in which the modem acts as a proxy ARP agent for a local public subnet. The modem will be assigned an IP address from within that public subnet. The modem will direct all traffic to a VersaLink, which is configured statically. VersaLink address must not reside within VersaLink's assigned public subnet. All traffic will be sent via VersaLink's MAC address. The LAN may also have a private NAT'ed network. NAT will use the global address assigned to the modem.</p>
	<p>VLAN = Assigns VLAN tags to individual data ports on the modem.</p>

If you selected the **Routed Bridge** mode under **VC 1 - Bridge Settings**, the following screen will be displayed. Enter the appropriate values in the fields and click on **set VC**.

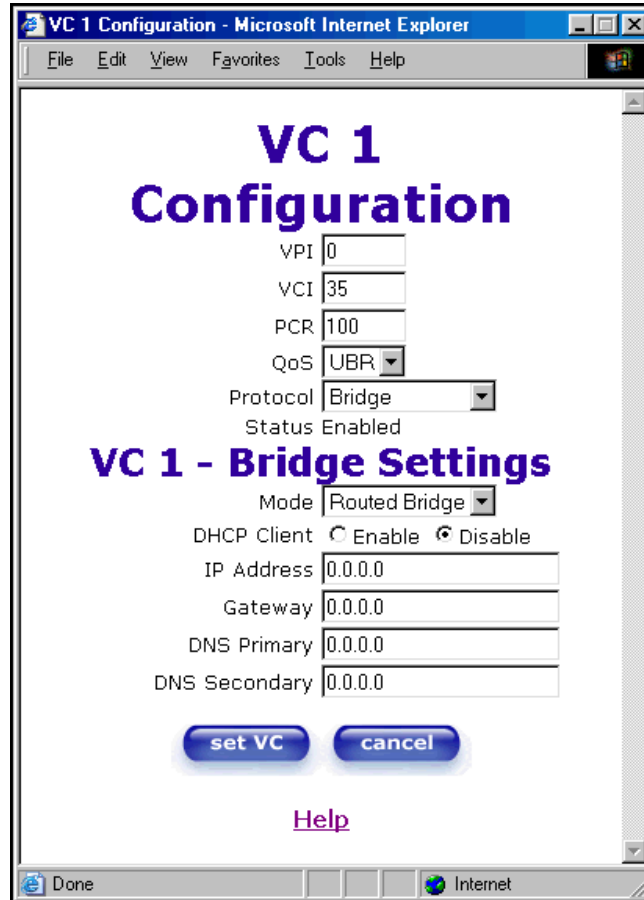

VC 1 - Bridge Settings (Routed Bridge)	
Mode	The Mode you have selected to use with Bridge protocol.
DHCP Client	Selecting a radio button allows you to either Enable or Disable the DHCP Client.
IP Address	Displays the IP network address that your modem is on.
Gateway	Displays the modem's IP gateway address.
DNS Primary	Provided by your Service Provider.
DNS Secondary	Provided by your Service Provider.

If you selected **Proxy Bridge** mode under **VC 1- Bridge Settings**, the following screen will be displayed. Enter the appropriate values in the fields and click on **set VC**.

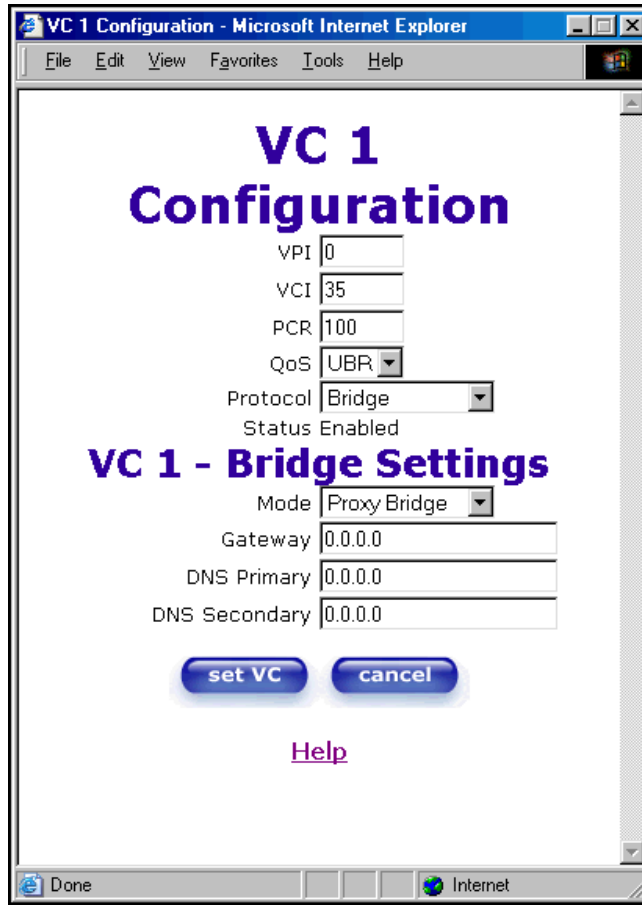

VC 1 - Bridge Settings (Proxy Bridge)	
Mode	The Mode you have selected to use with Bridge protocol.
Gateway	Displays the modem's IP address.
DNS Primary	Provided by your Service Provider.
DNS Secondary	Provided by your Service Provider.

If you selected **VLAN Bridge** under **VC 1 - Bridge Settings**, the following screen will be displayed. Enter the appropriate values in the fields and click on **set VC**.

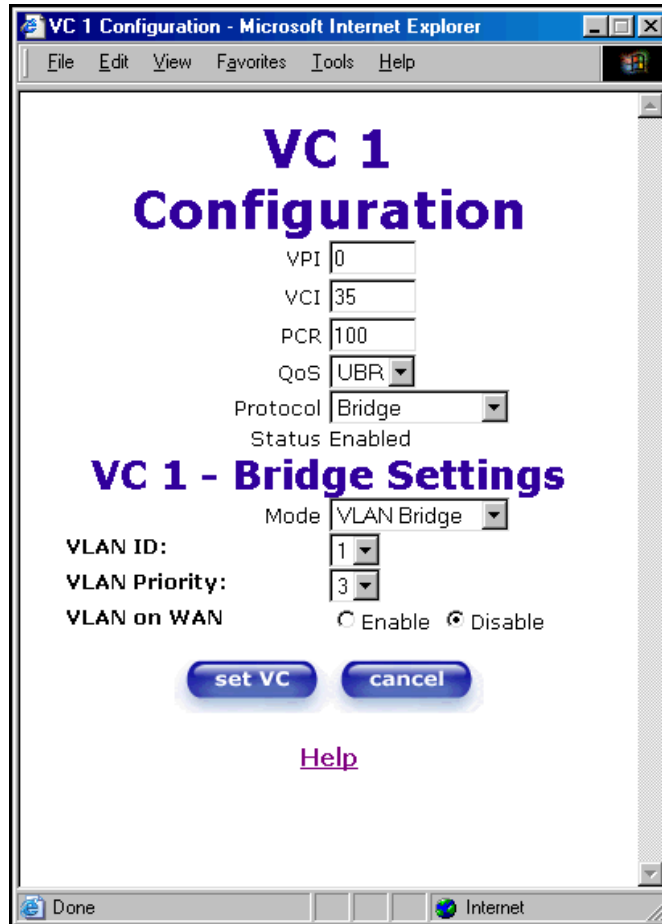

VC 1 - Bridge Settings (VLAN Bridge)	
Mode	The Mode you have selected to use with Bridge protocol. VLAN is used to assign VLAN tags to individual data ports on the modem.
VLAN ID	Assigns a VLAN ID to the port.
VLAN Priority	This will set the VLAN priority for the port.
VLAN on WAN	Factory Default = DISABLE Selecting Enable allows VLAN tagging to occur according to the data port's configuration.

After you have configured the VC 1 Configuration screen, you must click the **set VC** button to save your VC settings.

VC 1 Configuration

VPI
VCI
PCR
QoS
Protocol
Status Enabled

VC 1 - Bridge Settings

Mode
DHCP Client Enable Disable
IP Address
Subnet Mask
Gateway
DNS Primary
DNS Secondary

[Help](#)

If you click the **set VC** button, the following pop-up screen will be displayed. Click on **OK** in the pop-up screen. If you click on **Cancel**, the new settings will not be saved. After you click on **OK**, follow the instructions to reset the Gateway, as previously discussed in section 12.6.3.

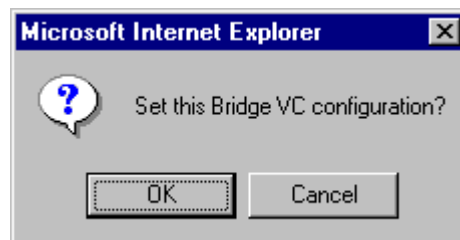

12.6.6 Configuring VC Protocol Settings for ETHERNET PORT 1

To configure the Gateway's VC settings via the Ethernet uplink port, select **ETHERNET PORT 1** at the **WAN Port** drop-down arrow.

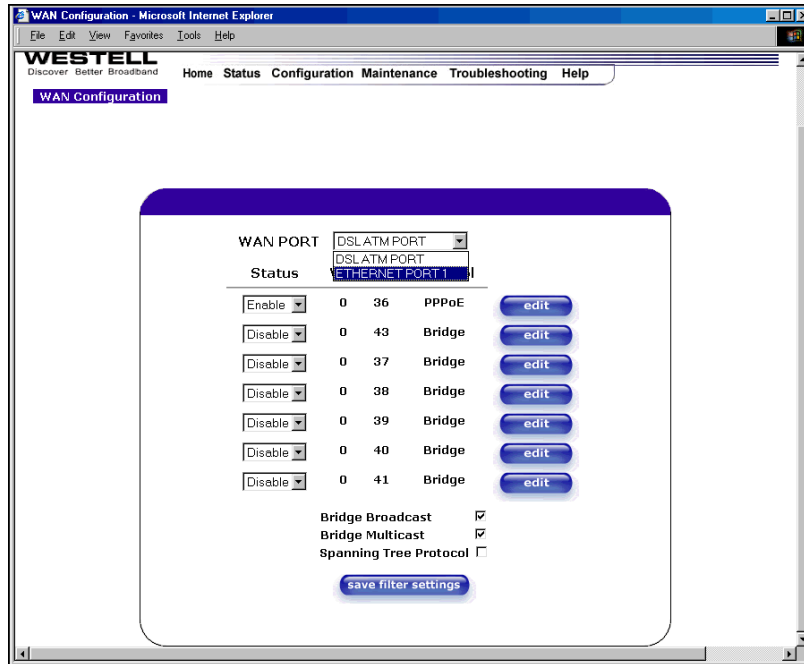

If you select **ETHERNET PORT 1**, the following pop-up will be displayed. Click on **OK**.

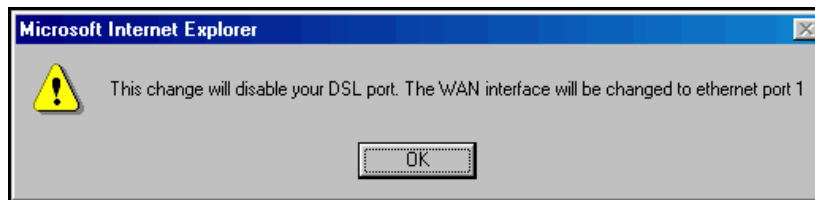

If you click on **OK**, the following pop-up screen will be displayed. Click on **OK**.

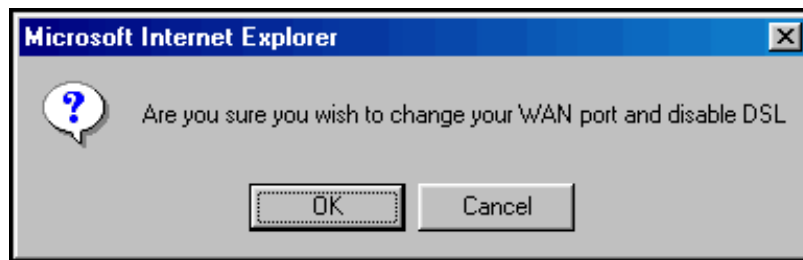

If you click on **OK** in the preceding pop-up screen, the following pop-up screen will be displayed. Click on **OK**.

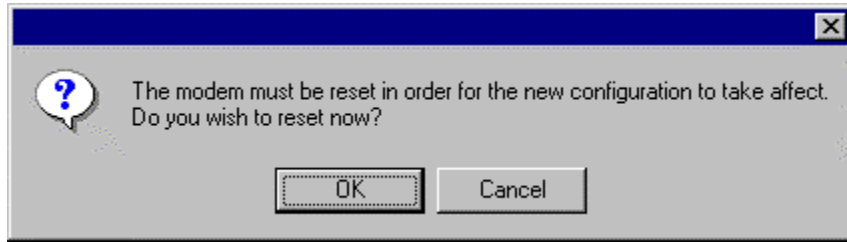

If you clicked on **OK**, the following screen will be displayed. VersaLink™ will be reset and the new configuration will take effect.

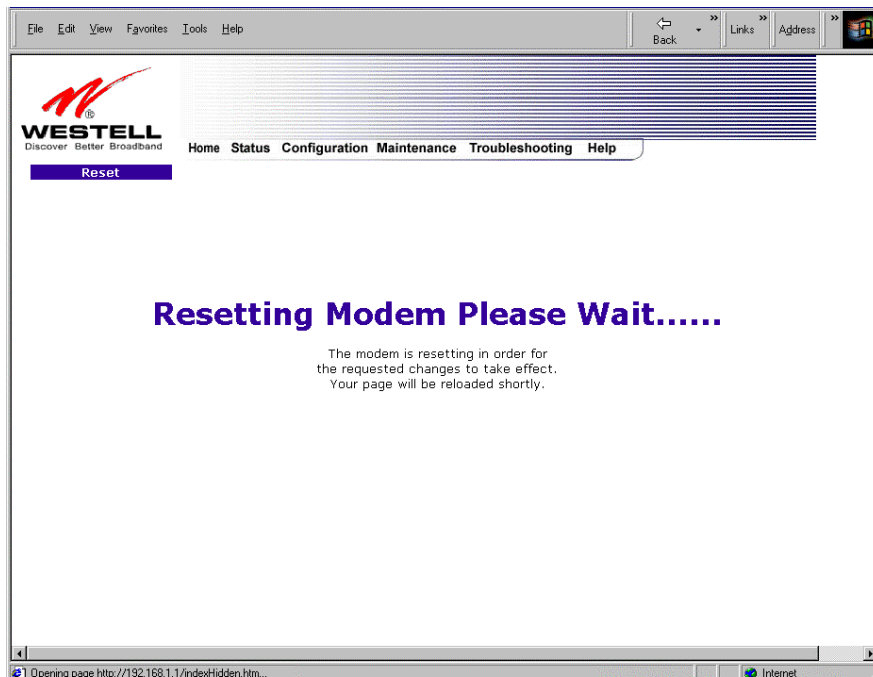

After the Gateway has been reset, from the **Configuration** menu, select **Advanced WAN** and then select **WAN**. The following screen will be displayed

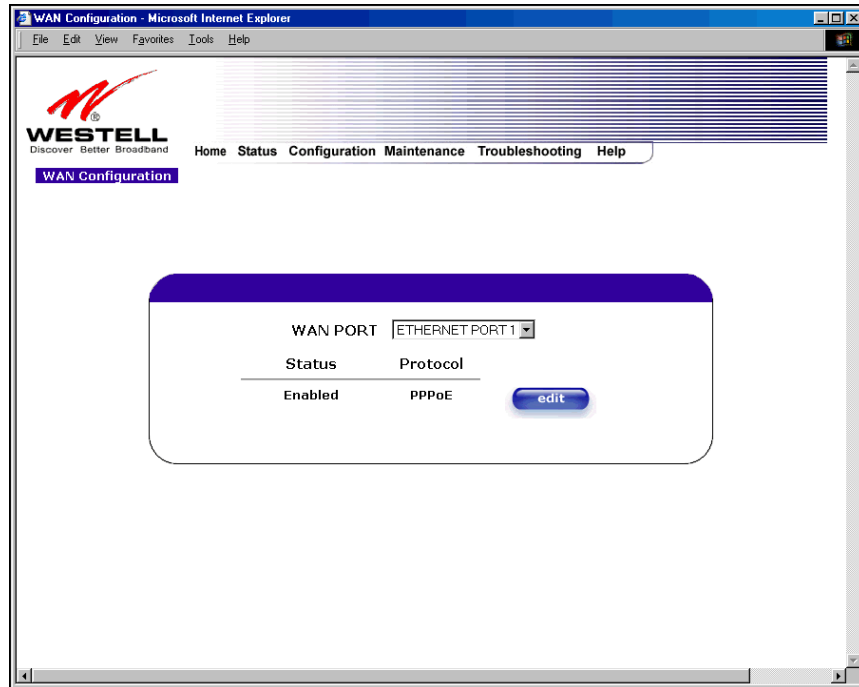

If you click **edit**, the following screen will be displayed. By using this screen, you can configure the WAN Ethernet port settings of your Gateway.

WAN Ethernet Configuration

Protocol
Status Enabled

PPPoE Settings

IP Address
Gateway
DNS Primary
DNS Secondary
Subnet Mask
MRU Negotiation
LCP Echo Disable
LCP Echo Failures
"Must be between 1 and 30 inclusive."
LCP Echo Duration
"Must be between 5 and 300 seconds inclusive and greater or equal to Retry Duration."
LCP Echo Retry Duration
"Must be between 5 and 300 seconds inclusive."
Tunneling Enable Disable

[Help](#)

To configure the WAN Ethernet port for routed bridge protocol, select **ROUTED** from the **Protocol** drop-down arrow.

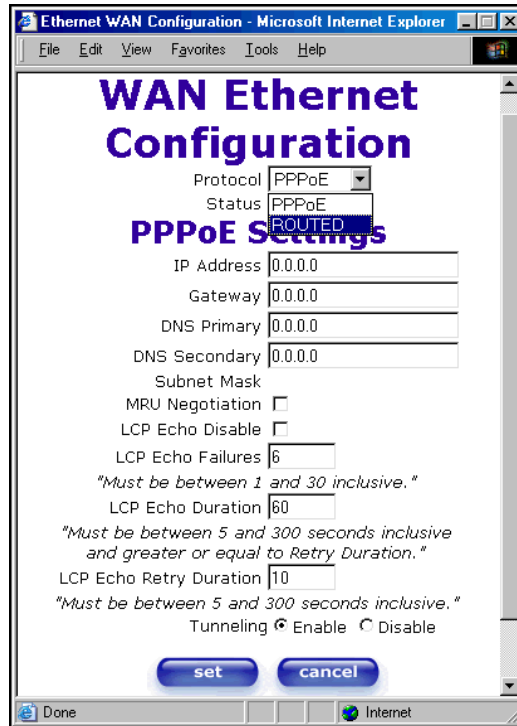

If you select **ROUTED**, the following screen will be displayed. Enter the appropriate values in the fields and click on **set**.

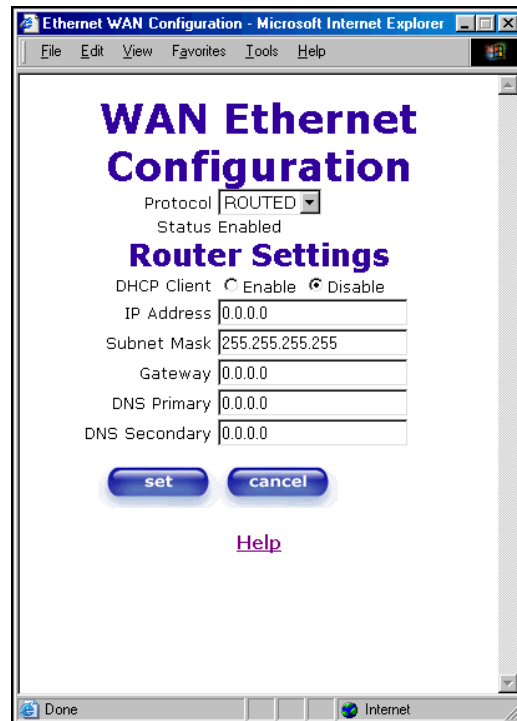

If you click on **set**, the following pop-up screen will be displayed. Click on **OK**.



If you clicked on **OK** in the preceding pop-up screen, the following pop-up screen will appear. VersaLink must be reset to allow the new configuration to take effect. Click on **OK**.

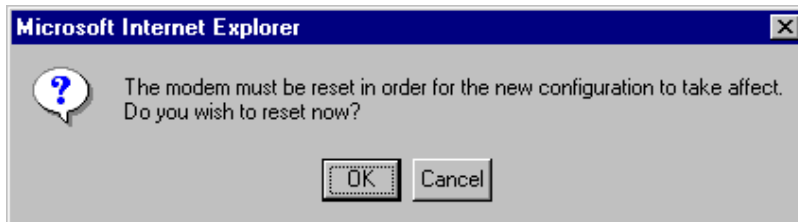

If you clicked on **OK** in the preceding screen, the following screen will be displayed. VersaLink will be reset and the new configuration will take effect.

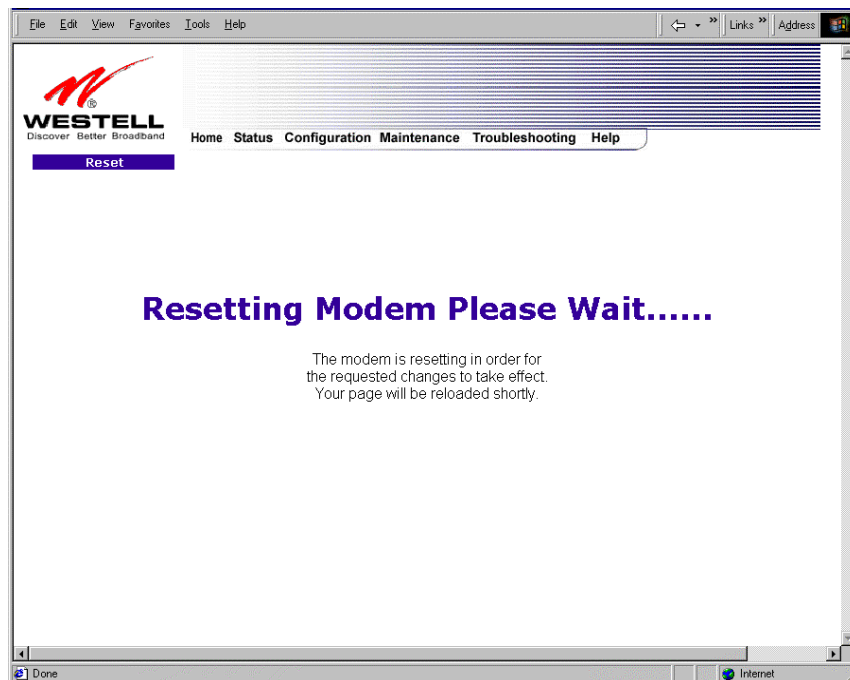

After the modem has been reset, the **WAN Configuration** screen will display **Routed Bridge** as the protocol for **ETHERNET PORT 1**.

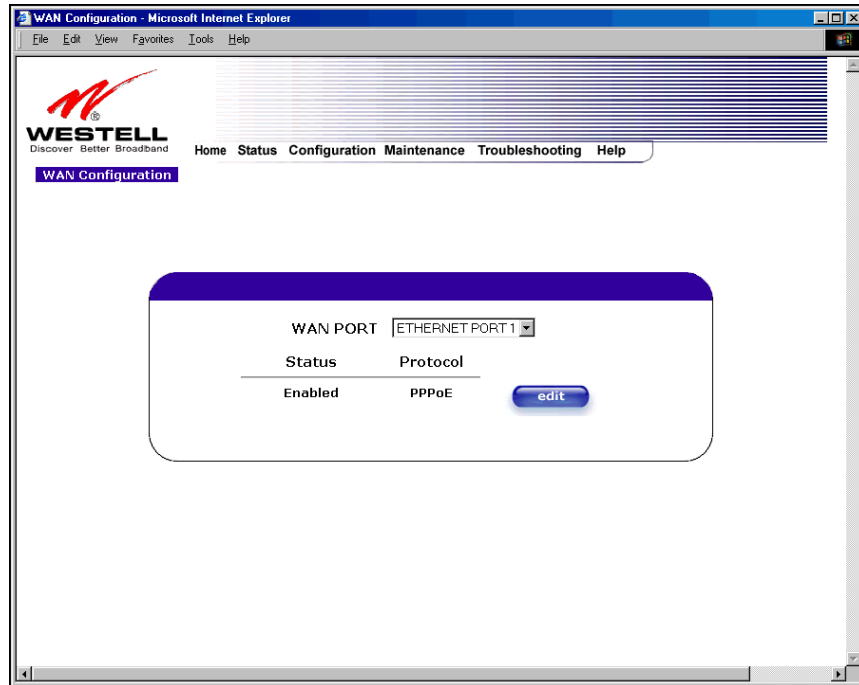

12.6.7 QOS

The following settings will be displayed if you select **QOS** from the **Advanced WAN** menu. If you change any settings in this screen, click on **save**. If you click on **reset**, this screen will refresh and display your last saved QoS configuration.

NOTE: The QOS feature helps ensure data integrity in high-speed transmissions. QOS provides the capability to partition network traffic into multiple priority levels or classes of service. After packet classification, other QOS features can be utilized to assign the appropriate traffic handling policies including congestion management, bandwidth allocation, and delay bounds for each traffic class.

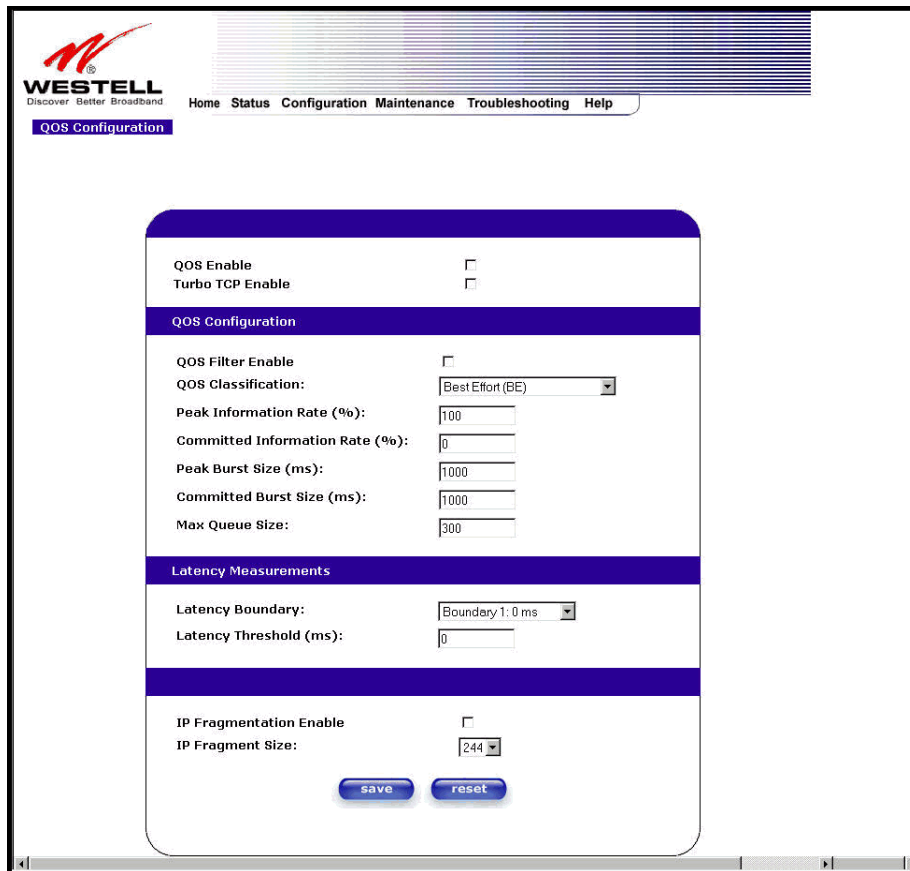

QOS Enable	Factory Default = DISABLED If this box is checked, Quality of Service (QOS) will be Enabled.
Turbo TCP Enable	Factory Default = DISABLED If this box is checked, Turbo TCP will be Enabled.
QOS Configuration	
QOS Filter Enable	Factory Default = DISABLED If this box is checked, this will Enable the QOS filter.
QOS Classification	This feature provides the capability to partition network traffic into multiple priority levels or classes of service. After packet classification, other QoS features can be utilized to assign the appropriate traffic handling policies including congestion management, bandwidth allocation, and delay bounds for each traffic class.

	<p>Possible responses are: Best Effort (BE) Assured Forwarding (AF1) Assured Forwarding (AF2) Assured Forwarding (AF3) Assured Forwarding (AF4) Expedited Forwarding (EF) Network Control (NC)</p>
Peak Information Rte (%)	The maximum allowed rate for this priority, expressed as a percentage of the DSL rate.
Committed Information Rate (%)	The committed rate for this priority, expressed as a percentage of the DSL rate.
Peak Burst Size	The interval in milliseconds for averaging the peak offered rate.
Committed Burst Size	The interval in milliseconds for averaging the committed offered rate.
Max Queue Size	The number of packets that can be queued for this priority.
Latency Measurements	
Latency Boundary	This configures the maximum latency boundary in milliseconds that a specific packet may be delayed by.
Latency Threshold (ms)	<p>This setting configures the maximum latency boundary in milliseconds that a specific packet may be delayed by.</p> <p>Possible responses are: Boundary 1:0 ms Boundary 2:10 ms Boundary 3:30 ms Boundary 4:40 ms Boundary 5:100 ms Boundary 6:1000 ms Boundary 7:3000 ms</p>
IP Fragmentation Enable	<p>Factory Default = DISABLED</p> <p>If this box is checked, IP Fragmentation will be Enabled. If Enabled and packets larger than 1500 bytes total are received, they will be fragmented.</p>
IP Fragment Size	<p>This is the IP Packet Size.</p> <p>Possible responses are: 100, 148, 244, 292, 340, 388, or 436</p>

If you made changes to the **QOS Configuration** and clicked on **save**, the following screen will be displayed. Click on **OK**. This will save your new QOS settings.

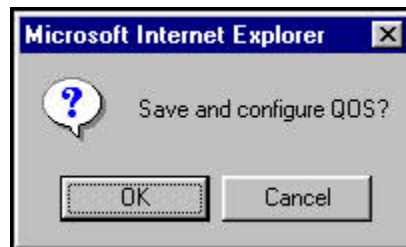

12.6.8 Route

The following settings will be displayed if you select **Route** from the **Advanced WAN** menu. The Route table maintains the routes or paths of where specific types of data shall be routed across a network.

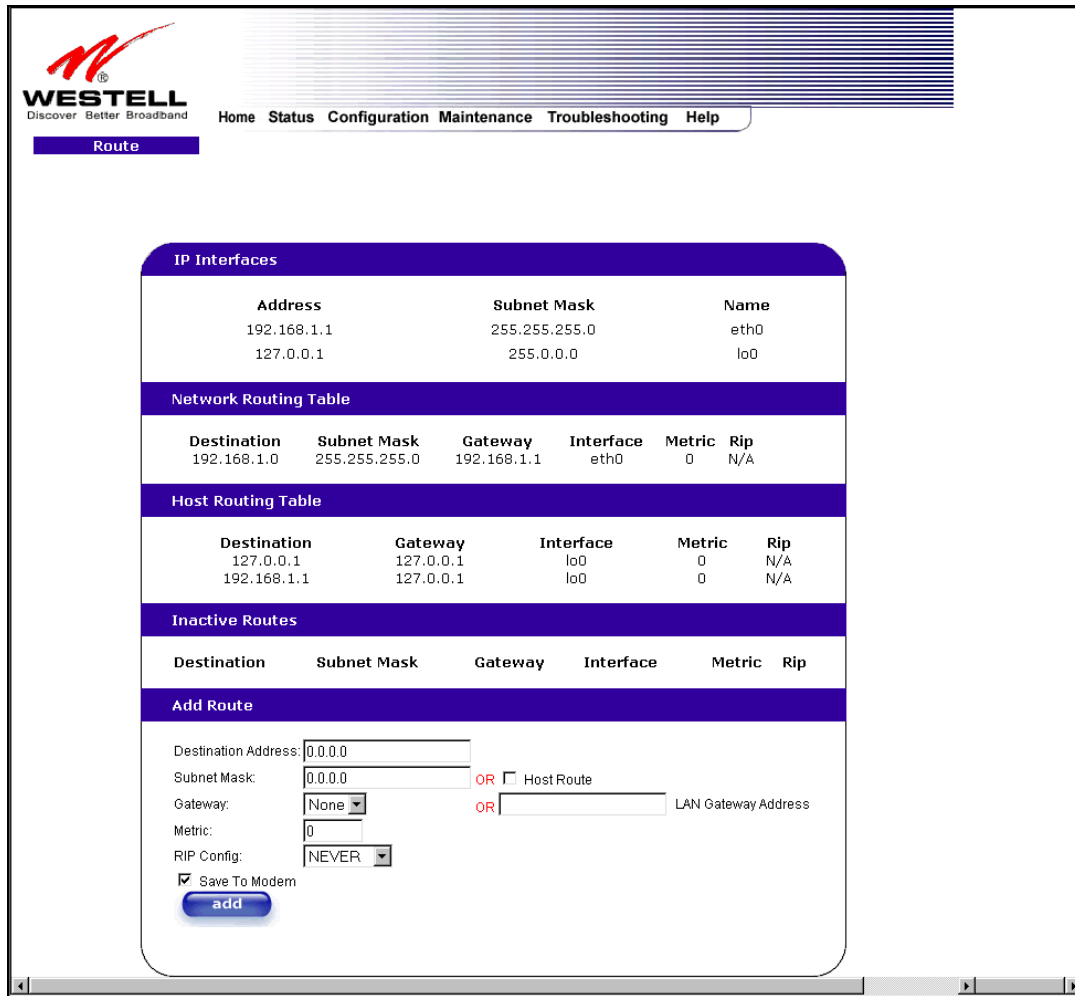

WESTELL
Discover Better Broadband

Home Status Configuration Maintenance Troubleshooting Help

Route

IP Interfaces

Address	Subnet Mask	Name
192.168.1.1	255.255.255.0	eth0
127.0.0.1	255.0.0.0	lo0

Network Routing Table

Destination	Subnet Mask	Gateway	Interface	Metric	Rip
192.168.1.0	255.255.255.0	192.168.1.1	eth0	0	N/A

Host Routing Table

Destination	Gateway	Interface	Metric	Rip
127.0.0.1	127.0.0.1	lo0	0	N/A
192.168.1.1	127.0.0.1	lo0	0	N/A

Inactive Routes

Destination	Subnet Mask	Gateway	Interface	Metric	Rip
-------------	-------------	---------	-----------	--------	-----

Add Route

Destination Address:

Subnet Mask: OR Host Route

Gateway: OR LAN Gateway Address

Metric:

RIP Config:

Save To Modem

NOTE: In this screen, VersaLink represents 'Gateway.'

To add a Route, enter a **Subnet Mask** address, or check the **Host Route** box. Click on the **add** button to establish a static route.

IP Interfaces	
IP Interfaces	The list of active interfaces on the modem and their IP and Subnet mask address. Eth0 is the local LAN interface. Lo0 is the loopback interface.
Address	The IP interface address.
Subnet Mask	The IP interface subnet address.
Name	The IP interface device name.
Network Routing Table	
Network Routing Table	The list of network routes. These can be either routes for directly connected interfaces or static routes.
Destination Address	The IP address or subnet of the Route.
Subnet Mask	If the Route is a network route, Subnet Mask is used to specify the subnet address. If the Route is a Host route, then the Host Route check box is used.
VersaLink	Indicates were to send the packet if it matches this route.
Interface	Indicates were to send the packet if it matches this route.
Metric	The RIP metric to be assigned to this route if and when it is advertised using RIP.
RIP	Indicates whether a static route should be advertised via RIP.
Host Routing Table	
Host Routing Table	The list of host routes. A host route is an IP route with a 32-bit mask, indicating a single destination (as opposed to a subnet, which could match several destinations.)
Destination Address	The IP address or subnet of the Route.
Subnet Mask	If the Route is a network route, Subnet Mask is used to specify the subnet address. If the Route is a Host route, then the Host Route check box is used.
VersaLink	Indicates were to send the packet if it matches this route.
Interface	Indicates were to send the packet if it matches this route.
Metric	The RIP metric to be assigned to this route if and when it is advertised using RIP.
RIP	Indicates whether a static route should be advertised via RIP.
Inactive Routes	
Inactive Routes	Static routes whose interface is currently not in service.
Destination Address	The IP address or subnet of the Route.
Subnet Mask	If the Route is a network route, Subnet Mask is used to specify the subnet address. If the Route is a Host route, then the Host Route check box is used.
VersaLink	Indicates were to send the packet if it matches this route.
Interface	Indicates were to send the packet if it matches this route.
Metric	The RIP metric to be assigned to this route if and when it is advertised using RIP.
RIP	Indicates whether a static route should be advertised via RIP.
Add Route	
Add Route	This is used to add a new static route in the modem.
Destination Address	The IP address or subnet of the Route.
Subnet Mask/ Host Route	If the Route is a network route, Subnet Mask is used to specify the subnet address. If the Route is a Host route, then the Host Route check box is used.
VersaLink/IP Address	The interface to use for sending the packet, if it matches this route. (Only active VersaLinks can be used to create a static route.)
Metric	The RIP metric to be assigned to this route if and when it is advertised using RIP.
RIP Conf	Determines whether or not to advertise the static route, using RIP. (RIP must also be enabled before the route will be advertised.)
Save to Modem	If checked, then the route will be made permanent by saving it to flash memory. If not checked, the route will disappear the next time the modem restarts.

12.6.9 RIP

The following details will be displayed if you select **RIP** from the **Advanced WAN** menu. If you change any settings in this screen, click on **save**. If you click on **reset**, this screen will refresh and display your last saved RIP configuration.

RIP (Routing Interface Protocol) is a dynamic inter-network routing protocol primarily used in interior routing environments. A dynamic routing protocol, as opposed to a static routing protocol, automatically discovers routes and builds routing tables.

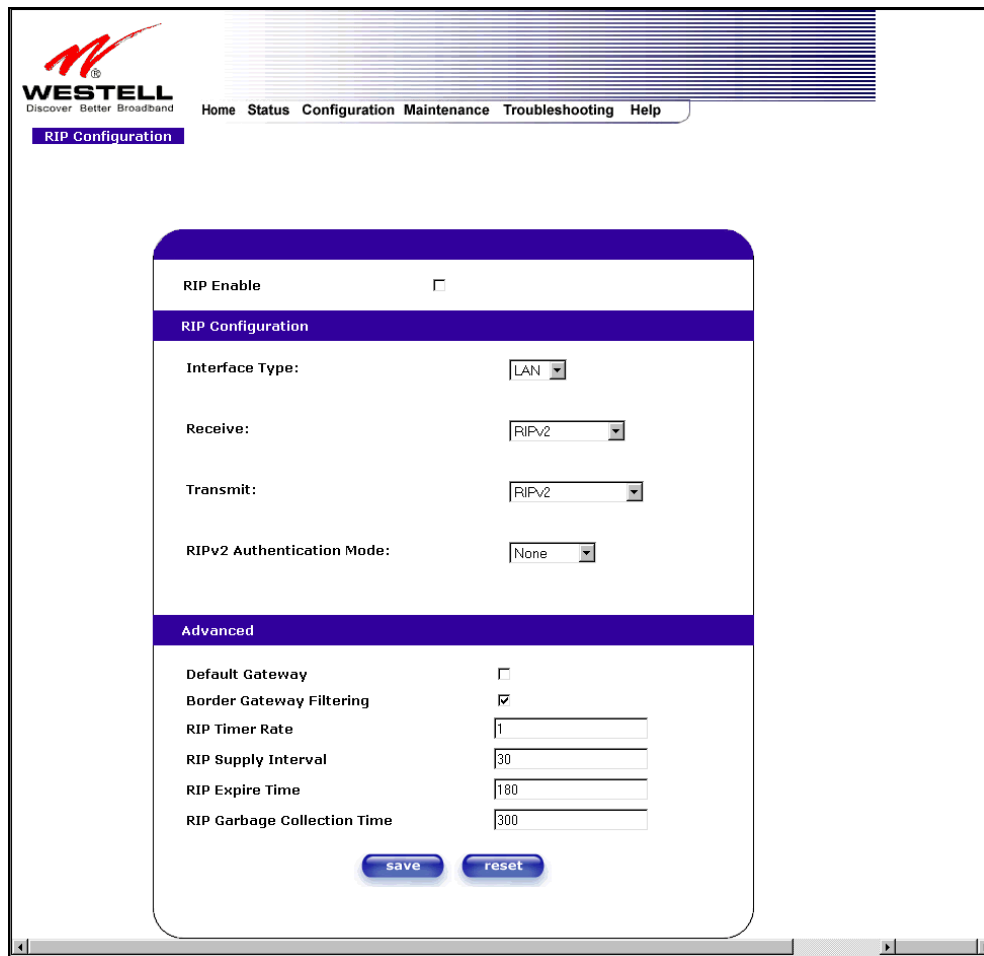

The screenshot shows the Westell VersaLink Gateway web interface for RIP Configuration. The page has a blue header with the Westell logo and navigation links: Home, Status, Configuration, Maintenance, Troubleshooting, and Help. Below the header is a sub-header for 'RIP Configuration'. The main content area is divided into two sections: 'RIP Configuration' and 'Advanced'. In the 'RIP Configuration' section, there is a 'RIP Enable' checkbox (unchecked), an 'Interface Type' dropdown menu (set to 'LAN'), 'Receive' and 'Transmit' dropdown menus (both set to 'RIPv2'), and a 'RIPv2 Authentication Mode' dropdown menu (set to 'None'). The 'Advanced' section contains several settings: 'Default Gateway' (checkbox, unchecked), 'Border Gateway Filtering' (checkbox, checked), 'RIP Timer Rate' (text input, '1'), 'RIP Supply Interval' (text input, '30'), 'RIP Expire Time' (text input, '180'), and 'RIP Garbage Collection Time' (text input, '300'). At the bottom of the form are 'save' and 'reset' buttons.

NOTE: In this screen, VersaLink represents 'Gateway.'

RIP Enable	Factory Default = DISABLED If this box is checked, RIP will be Enabled (turned ON).
RIP Configuration	
Interface Type	LAN: Select this if you are configuring RIP for the LAN side. WAN: Select this if you are configuring RIP for the WAN side. (WAN side is receive only.)
Receive	The version of RIP to be accepted. Possible responses are: None RIPv1 RIPv2 RIPv1 or RIPv2
Transmit	The version of RIP to be transmitted. (WAN side RIP never transmits) Possible responses are: None RIPv1 RIPv1 Compatible RIPv2
RIPv2 Authentication Mode	If using RIP V2, you must select the type of authentication to use. Possible responses are: None Clear Text MD5 (If MD5 authentication, the password)
Advanced	
Default VersaLink	Factory Default = DISABLED If this box is check (Enabled), this feature will determine whether the modem advertises itself as a VersaLink (i.e., the default route)
Border VersaLink Filtering	Factory Default = ENABLED If this box is unchecked (Disabled), the modem will not summarize subnets into a single route before advertising.
RIP Timer Rate	Indicates how often to update the local routing table.
RIP Supply Interval	Indicates how often to advertise routes to neighbors.
RIP Expire Time	Indicates how long routes received from neighbors become invalid, if no refresh of the route is received.
RIP Garbage Collection Time	Indicates how long to advertise invalid routes after they have expired.

If you change any settings in the **RIP Configuration** screen and clicke on **save**, the following screen will be displayed. Click on **OK** to save your new RIP settings.



13. SETTING UP ADVANCED SERVICE CONFIGURATION

You can set up additional Service Configuration options for VersaLink that allow you to enter the port forwarding and trigger ports ranges of your choice. Go to **Configuration** at the homepage menu and select **Services**.

When you click on **define custom service** in the **Service Configuration** screen, the **Custom Service** screen will guide you through the steps of creating an advanced NAT service entry via the **define custom service** button.

NOTE: Westell strongly recommends that you do not change any values in this section. If you experience any problems, please reset VersaLink via the external hardware reset button or the procedure defined under the **Maintenance** menu.

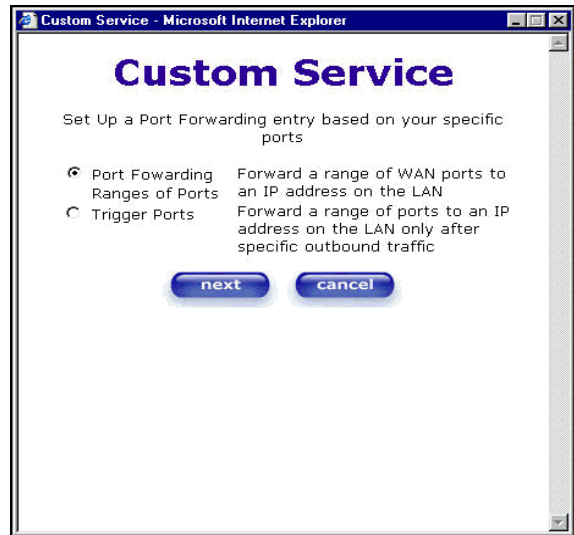
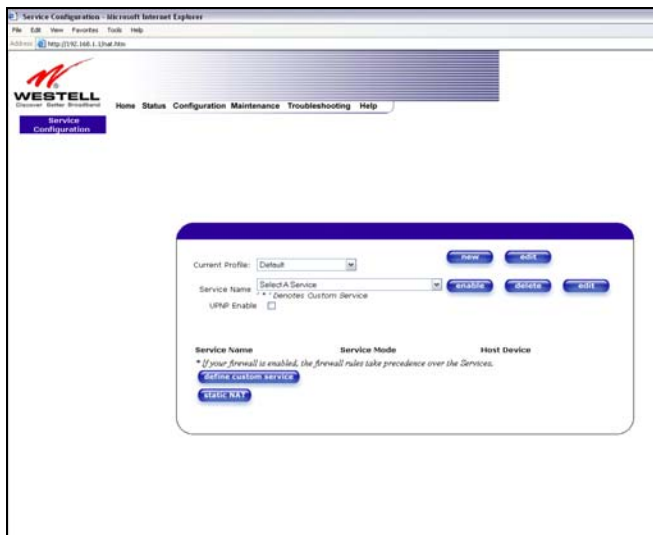

Port Forwarding Ranges of Ports	This option allows you to forward a range of WAN ports to an IP address on the LAN.
Trigger Ports	This option allows you to forward a range of ports to an IP address on the LAN only after specific outbound traffic.

13.1 Port Forwarding Ranges of Ports

To select **Port Forwarding Ranges of Ports**, click on **define custom service** from the **Service Configuration** screen, and then select **Port Forwarding Ranges of Ports** from the **Custom Service** screen. Click on **Next**. The **Port Range** screen will be displayed. Enter your values in the **Global Port Range** fields and click **next** to continue.

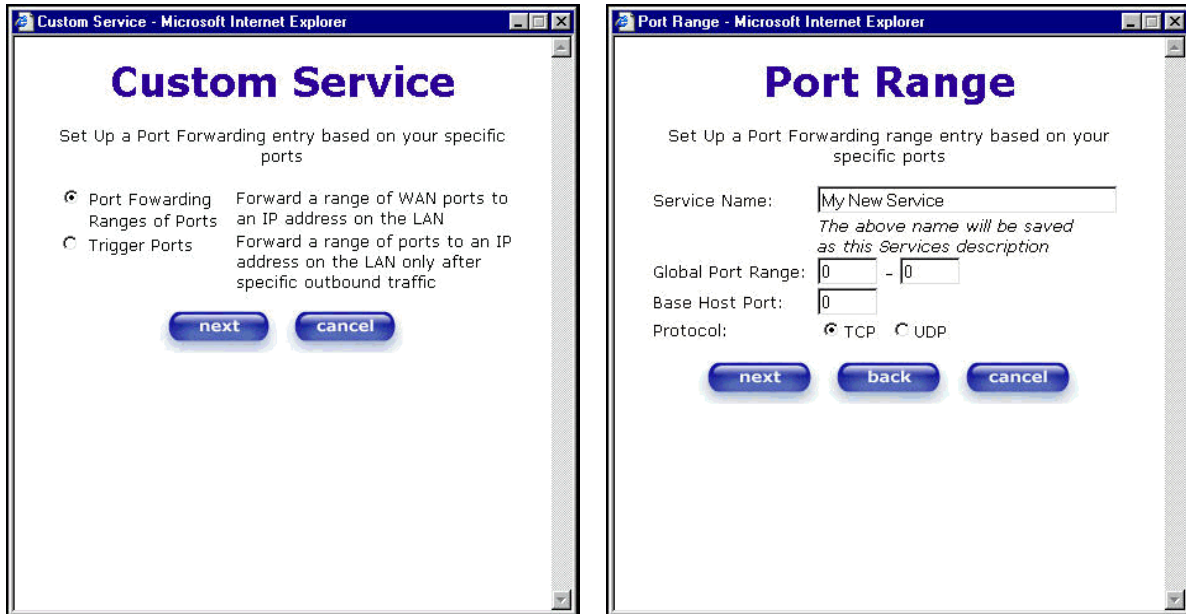

13.2 Adding Port Forwarding Ports

If you made changes in the **Port Range** screen and clicked on **next**, the following screen will be displayed. Click on **close** to accept the changes, or click on **add** to go back to **Port Range** screen and enter additional port range values. You can repeat this step for each range of ports that you want to add (up to 62 port forwarding ranges). When you are finished adding ports to the Global Port Range, you must click on **close** to accept the information you have entered and return to the **Service Configuration** screen.

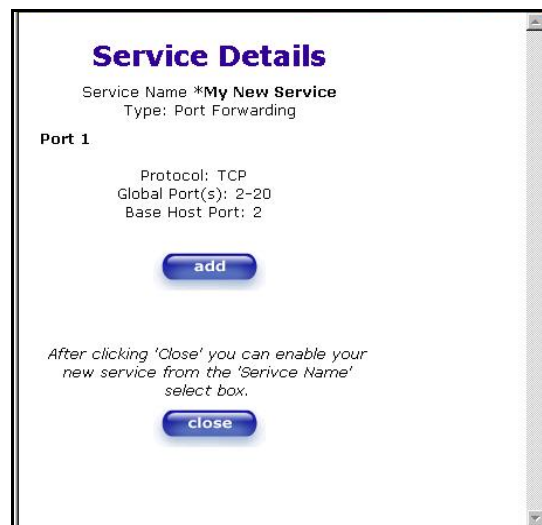

Service Name	The NAT service for which you are configuring Port Forwarding.
Type	The type of NAT service configuration you selected.
Protocol	The type of Protocol that is used to run this NAT service. TCP- Transmission Control Protocol. UDP-User Datagram Protocol (UDP).
Local IP Address	If a static IP address has been assigned, it will be displayed here.
Base Host Port	The port on the WAN that will host the NAT service selected. Base Host Port is the first port that will be used for a specific service when configured for a range of ports.

13.3 Port Forwarding Trigger Ports

To select **Port Forwarding Trigger Ports**, click on **define custom service** from the **Service Configuration** screen, and then select **Trigger Ports** from the **Custom Service** screen. Click on **next**. The follow settings will be displayed in the **Trigger Ports** screen. Enter your values in the **Local 'Trigger' Port Range** fields and click on **next** to continue.

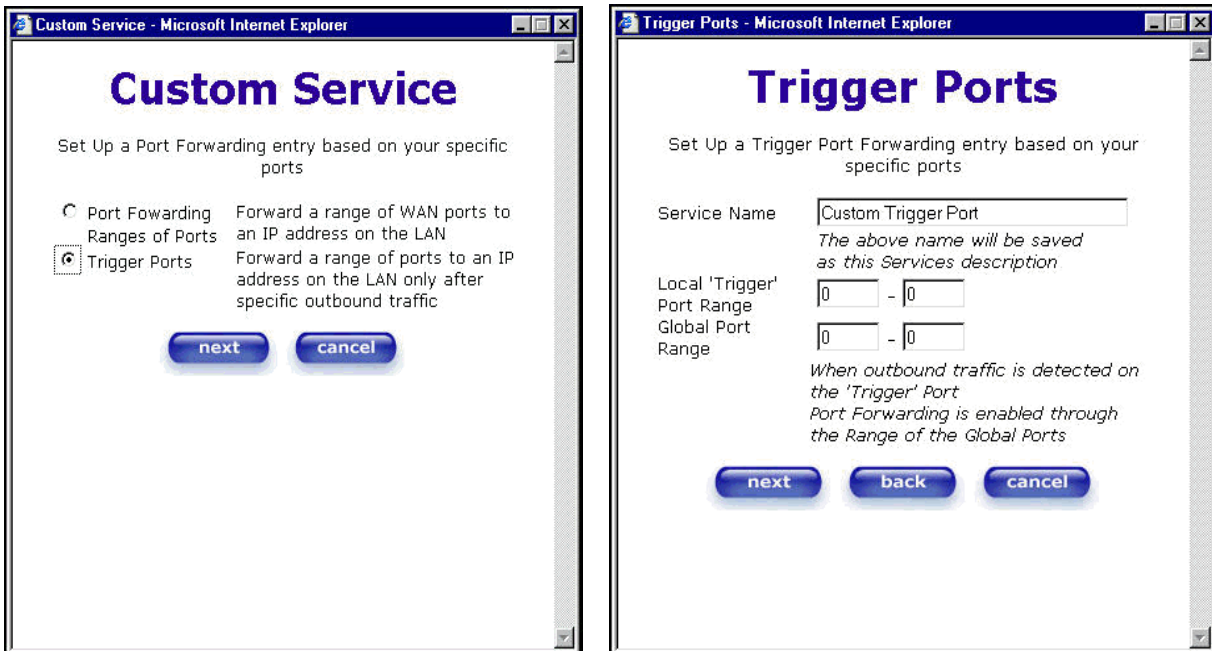

Service Name	The NAT service you selected.
Local Trigger Port Range	The local LAN side TCP/UDP port.
Global Port Range	The WAN side TCP/UDP port range.

13.4 Adding Local Trigger Ports

If you made changes in the **Local ‘Trigger’ Port Range** screen and clicked **next**, the following screen will be displayed. Click on **close** to accept the changes, or click on **add** to go back to the **Trigger Ports** screen and enter additional port range values. You can repeat this step for each port range that you want to add (up to 10 trigger ports). When you are finished adding ports to the Local ‘Trigger’ Port Range, you must click on **close** to accept the information you have entered and to return to the **Service Configuration** screen.

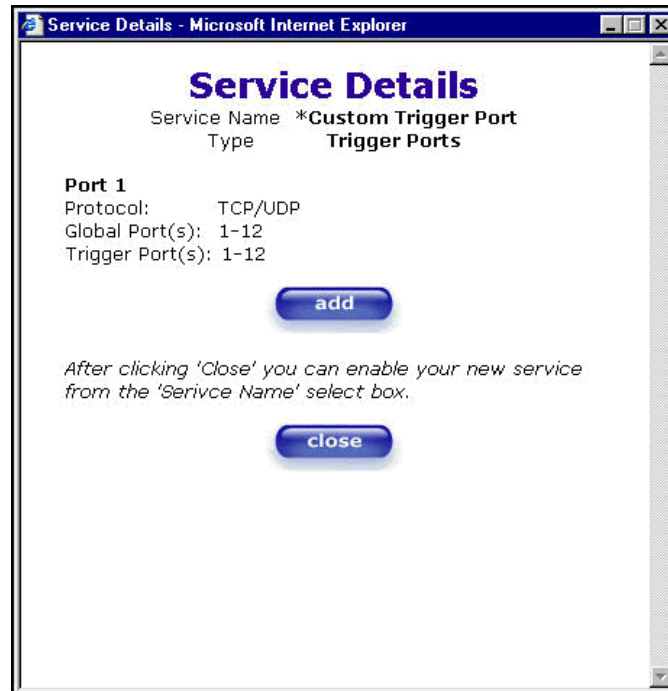

13.5 Static NAT

If you select **Services** from the **Configuration** menu, the following screen will be displayed, showing the **static NAT** button. Static NAT allows you to configure VersaLink to work with the special NAT services.

NOTE: When the Gateway is configured for Static NAT, any unsolicited packets arriving at the WAN would be forwarded to this device. This feature is used in cases where the user wants to host a server for a specific application.

IMPORTANT: Single Static IP must be disabled (if it has been enabled previously) before you enable **static NAT**. To disable Single Static IP, select **Single Static IP** from the **Configuration** menu. Next, click on the **disable** button, and then click on **OK** in the pop-up screens to allow the Gateway to be reset. As explained in section 12.1 (Single Static IP), you must reboot your computer after you enable or disable Single Static IP. After you have rebooted your computer, return to static NAT configuration screen by selecting **Services** from the **Configuration** menu and clicking on the **static NAT** button.

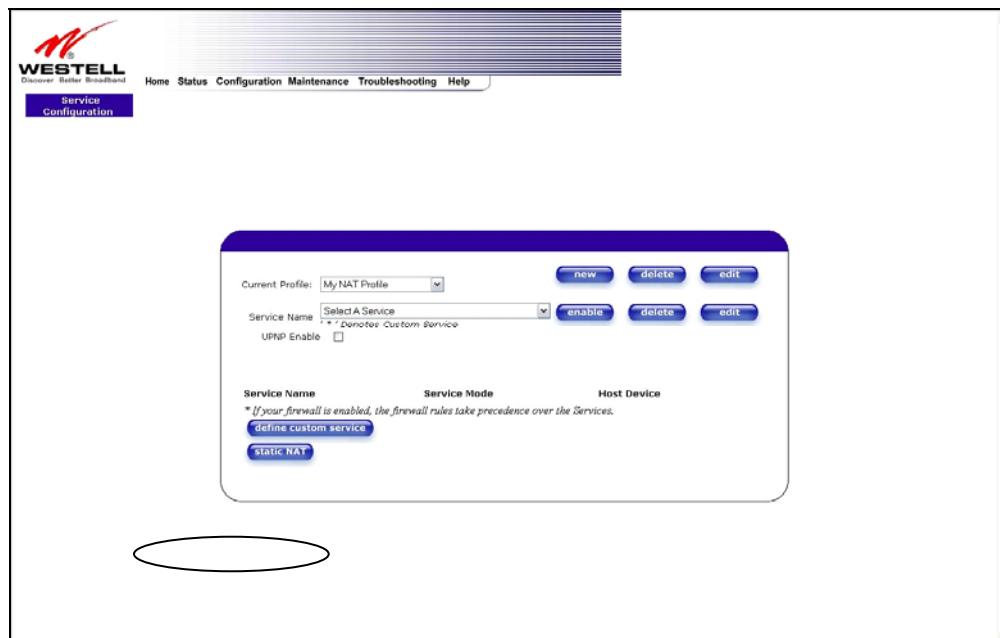

13.6 Enabling Static NAT

Before you enable static NAT, you must select **Default** from the **Current Profile** drop-down box. Static NAT must be configured for the Gateway's default account profile. After you select the default profile, click the **static NAT** button.

NOTE: In the following screen, the default account profile is labeled **Default**. However, if you have renamed the default account profile, you must select the profile name you created as the default profile.

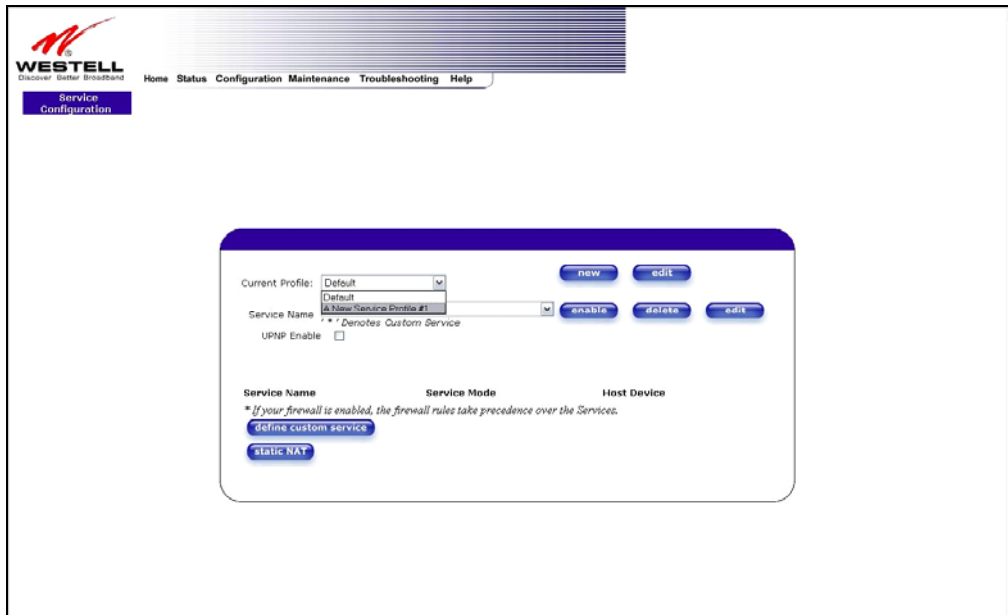

If you click on the **static NAT** button in the **Service Configuration** screen, the following screen will be displayed. Select your device from the **Static NAT Device** drop-down arrow, or type the IP address of the device in the field labeled **IP Address**. Click on **enable**. This will automatically enable the Static NAT feature for that device.

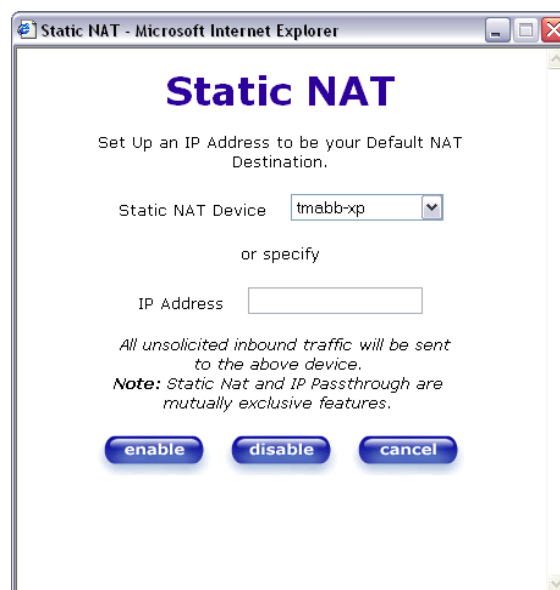

If you click **enable**, the following Service Configuration screen will display. Static NAT is now enabled for the device you selected.

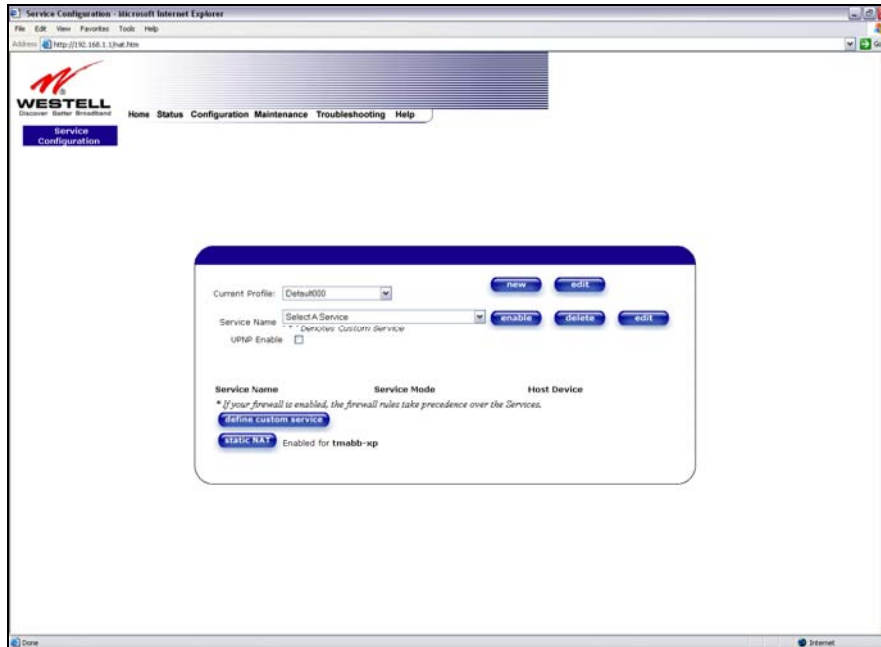

13.7 Disabling Static NAT

If you click on **static NAT** in the **Service Configuration** screen, the following screen will be displayed, select a device name from the **Static NAT Device** drop-down arrow, or type the IP address of the device in the field labeled **IP Address**. Click on **disable**. This will automatically disable the Static NAT feature for that device.

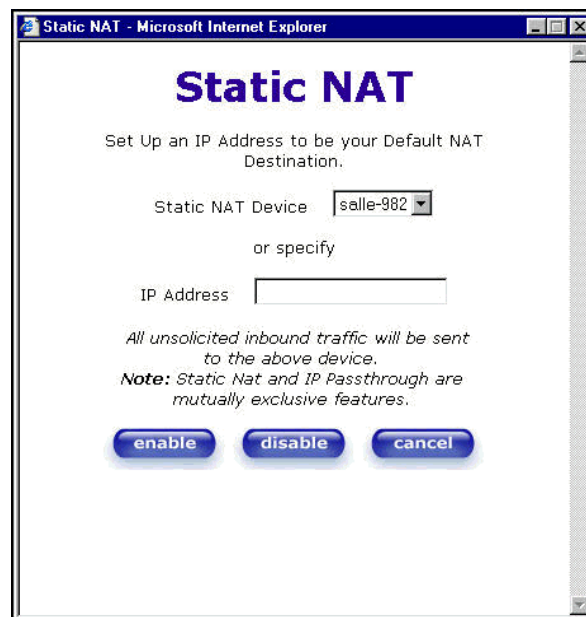

If you click **disable**, the following Service Configuration screen will be displayed. Static NAT is now disabled for the device you selected. (No device is displayed in the field adjacent to the **static Nat** button.)



14. MAINTENANCE

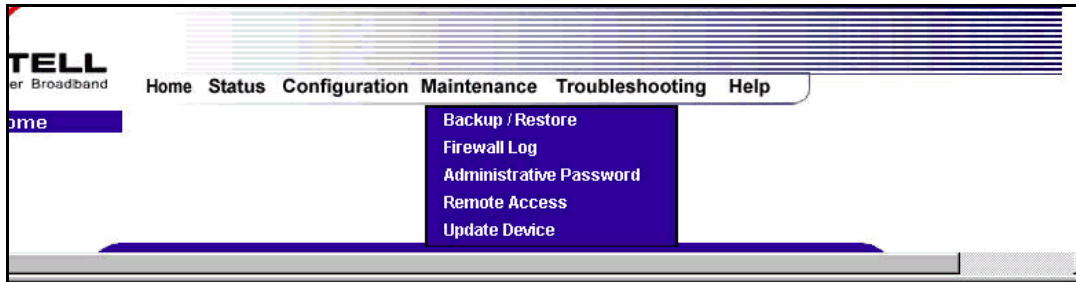

14.1 Backup/Restore

The following settings will be displayed if you select **Backup/Restore** from the **Maintenance** menu.

NOTE: Backup settings are stored in a separate area of flash, not to an external backup source.

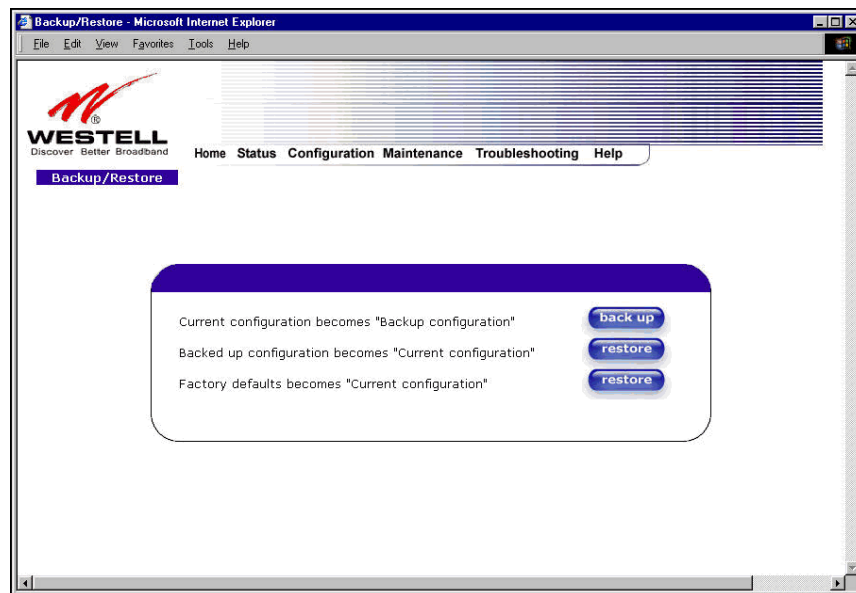

Current configuration becomes Backup Configuration	Select this button if you want to store all of the current configuration data such that it can be recalled later.
Backed up configuration becomes Current configuration	Select this button if you want to retrieve the last back up copy of all configuration parameters and make these values current.
Factory default becomes Current configuration	Select this button if you want set all user configurable parameters back to the factory default.

14.2 Firewall Log

The following settings will be displayed if you select **Firewall Log** from the **Maintenance** menu.

This screen is an advanced diagnostics screen. It alerts you of noteworthy information sent to VersaLink from the Internet. The screen can contain 1000 entries, but a maximum of 50 entries are displayed at a time. Once 1000 entries have been logged, the oldest entry is removed to make space for the new entries as they occur. The following settings are displayed.

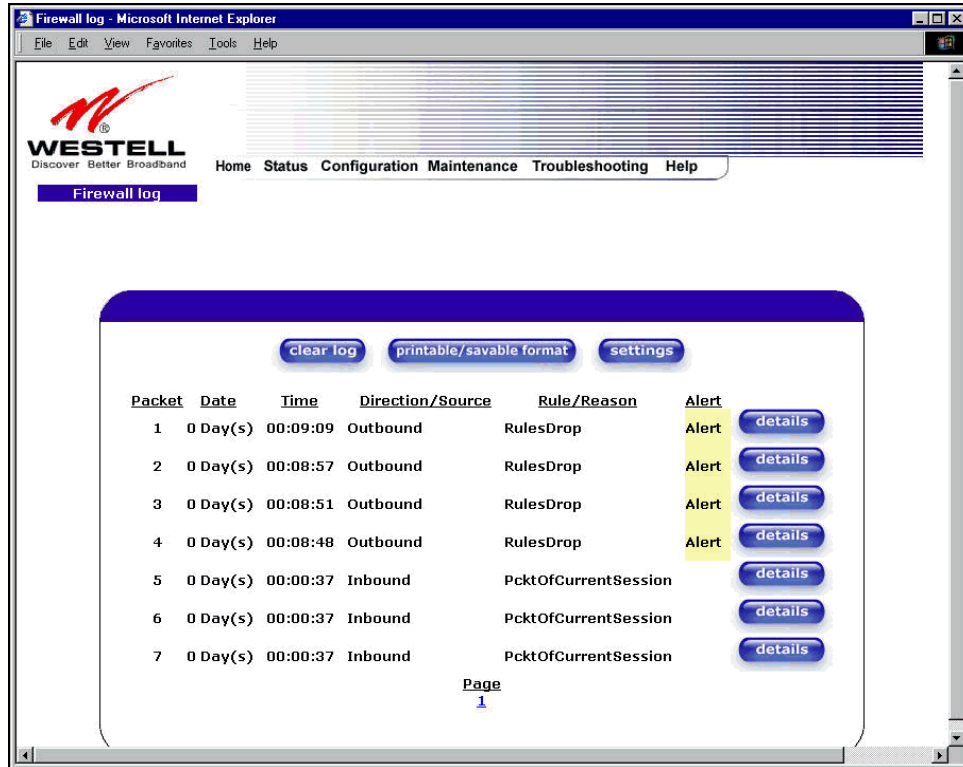

Clear log	Selecting this button removes all entries from the log.
Printable/savable format	Selecting this button opens a new window that contains a list of all the logged packets that can be saved or printed.
Settings	Selecting this button opens a new window that contains configuration settings for selecting the information that you want logged.
Packet	The packet number.
Date	The number of days passed since that the packet was sent.
Time	The time that the packet was sent.
Direction/Source	The direction of transmission.
Rule/Reason	The internal rule that caused the logged event. The internal rule is set up under Firewall rules.
Alert	Displays a description of the logged event.

If you clicked on **details** in the **Firewall Log** screen, the **Packet Details** screen will be displayed. Click on **close**.

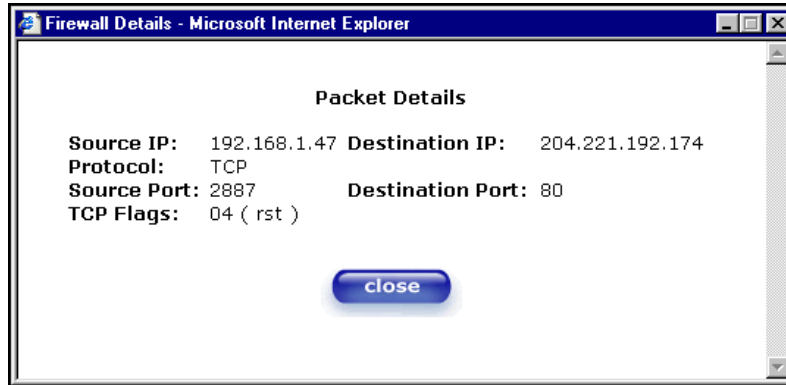

To clear the Firewall log, click **clear log** in the **Firewall Log** screen. The following pop-up screen will be displayed. Click **OK** when asked “Do you wish to clear the Firewall log file?” If you click **Cancel**, the firewall log will not be cleared.



To obtain a printable format of the Firewall Log, at the **Firewall Log** screen, click **Printable/Savable Format**. This will allow you to send a copy of the Firewall log to your designated printer.

14.3 Administrative Password

The following settings will be displayed if you select **Administrative Password** from the **Maintenance** menu. After you enter your data into the appropriate settings, click on **change**.

NOTE: If the Gateway is password protected and you are not an authorized user, you will not be able to change the values. (The Gateway cannot be configured unless the user is logged in.) Contact your network administrator for further instructions.

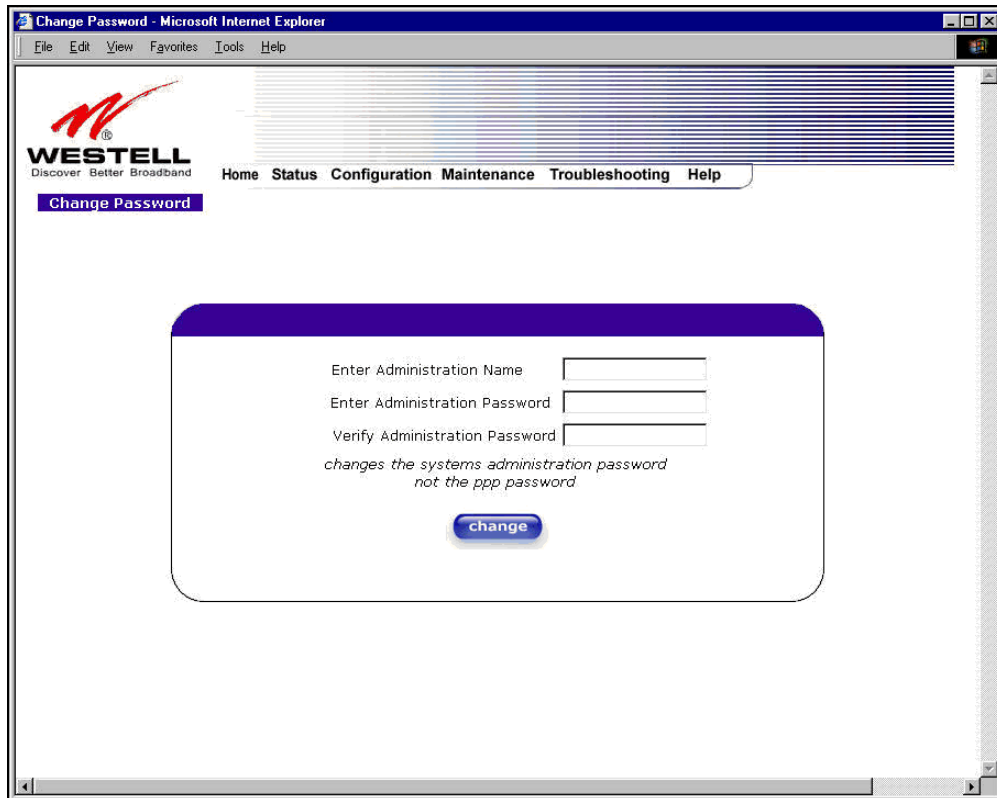

Enter Administrative Name NOTE: This changes the Systems Administrator password not the PPP password.	Type the name of your network administrative.
Enter Administrative Password	Type your network administrator's password.
Verify Administrative Password	Re-type your network administrator's password.

14.4 Remote Access

The following screen will appear if you select **Remote Access** from the **Maintenance** menu. To enable Remote Access, type in a password and click the **enable remote access** button.

NOTE: The password should be at least 4 characters long and should not exceed 32 characters. Do not type a blank space or asterisks in the Password field. The password is also case sensitive.

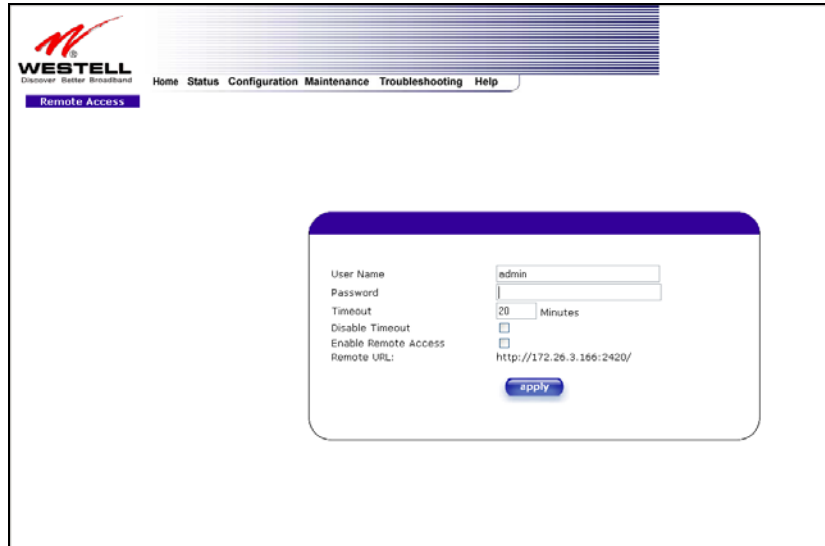

User Name	Displays your current User Name (Static field)
Password	Field for entering your password
URL	Displays the IP address of the remote management VersaLink

The following screen displays a message that the remote access is currently enabled. After 20 minutes of inactivity, or on reboot, remote access will be automatically disabled. To disable remote access, click on the **disable remote access** button.



14.5 Update Device

The following screen will be displayed if you click on **Update Device** from the **Maintenance** menu. This screen is used to update the firmware that controls the operation of VersaLink. The updated firmware may be loaded from either a file that is located on your PC's hard drive or from update files stored on an Internet server.

NOTE: The configurable settings of your Gateway may be erased during the update process.

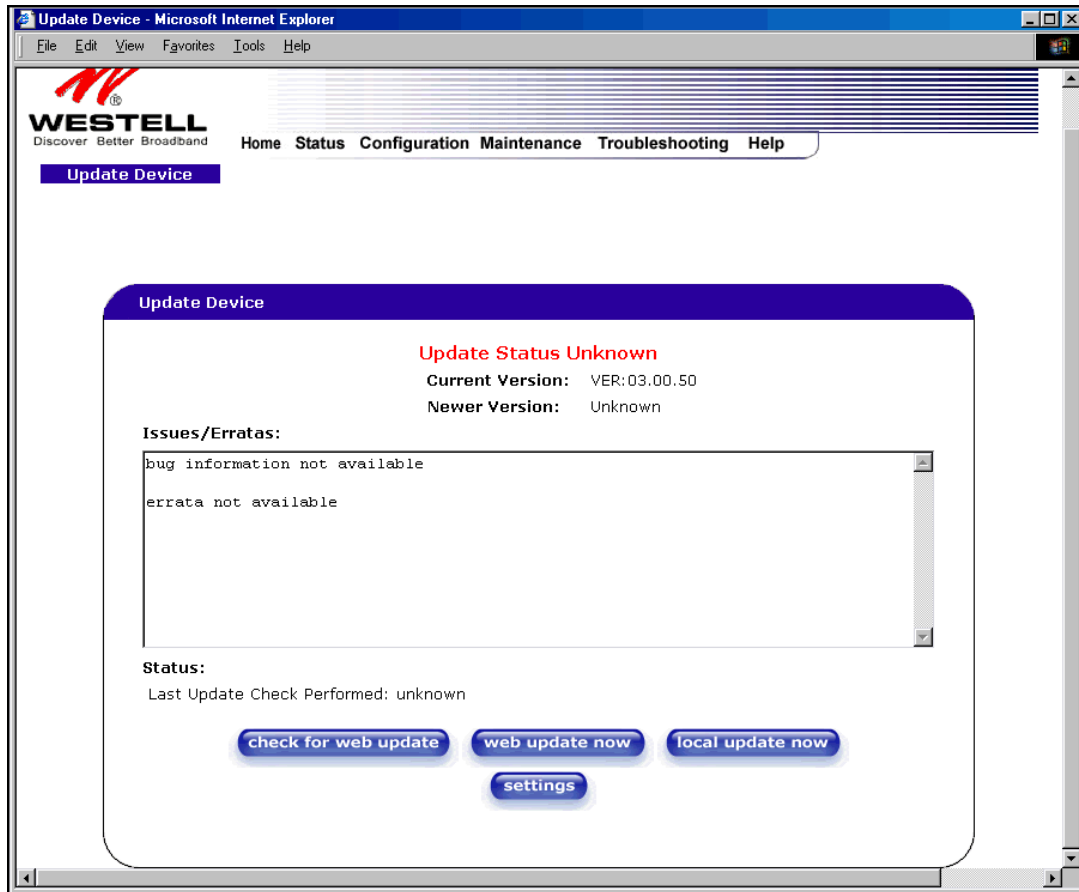

Click on the **check for web update** button in the **Update Device** screen to check the web for possible software updates. This screen will retrieve the software update file and display any available update information. You must be connected to the Internet to use this option.

NOTE: If you click on check for web update and the page returns a “page not found” message, this indicates that the software update file is not available. Go back to the previous screen to continue.

Click on the **web update now** button in the **Update Device** screen to download the software update file and automatically update the modem firmware if an update is available and applicable. You must be connected to the Internet to use this option.

If you click on the **settings** button in the **Update Device** screen, the following screen will appear. This screen displays the location of the software update file.

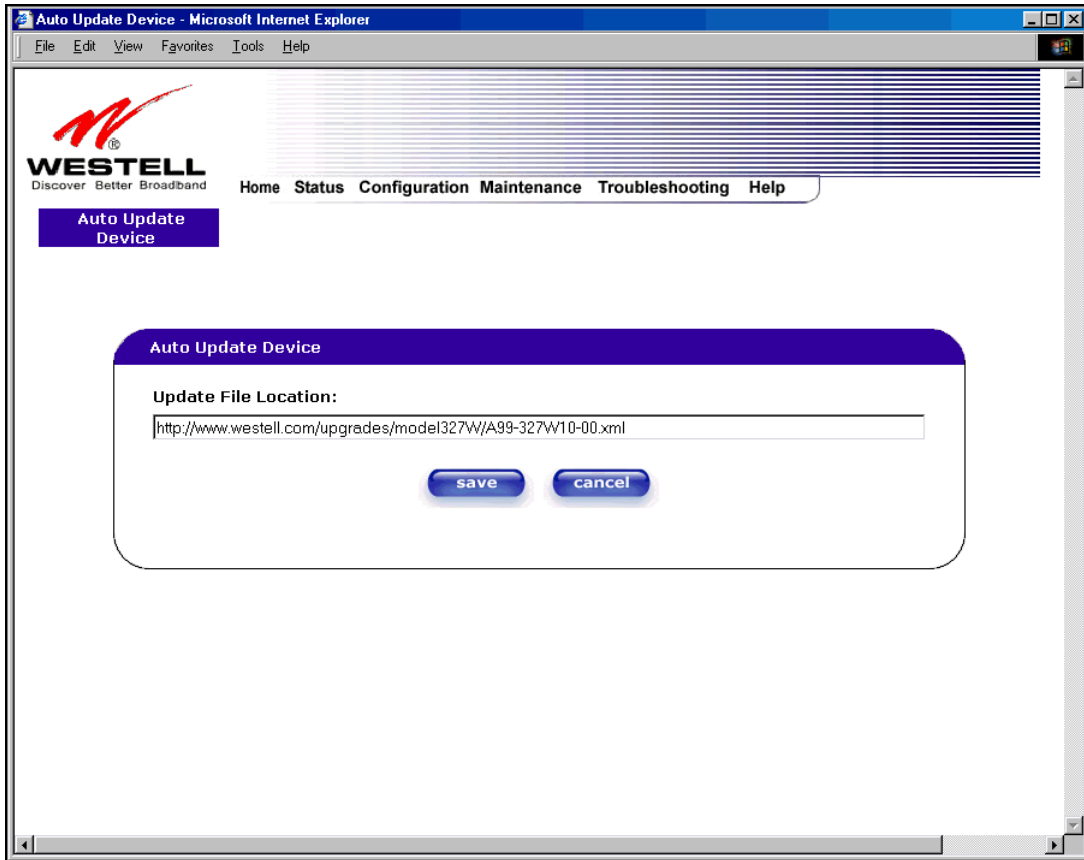

Click on the **local update now** button in the **Update Device** screen to select the upgrade file from your PC's hard drive. This screen allows you to upgrade the software on VersaLink. Click **Browse...** and go to the location where the upgrade file is stored.

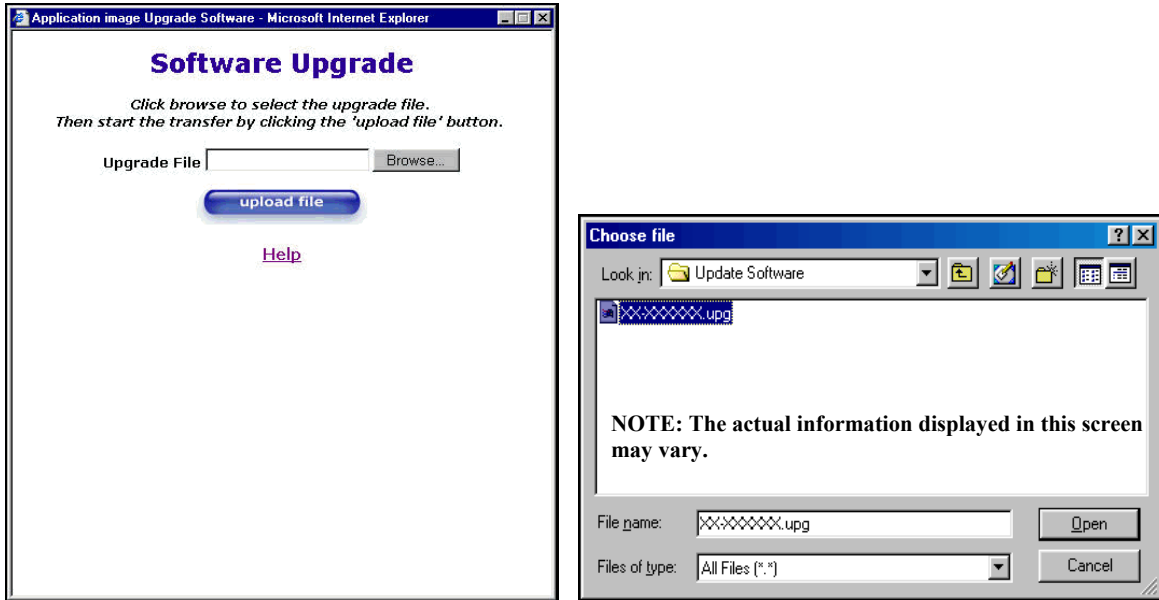

Select the appropriate upgrade file from your browser. The file name will appear in the field labeled **Upgrade File**. Click on **upload file**.

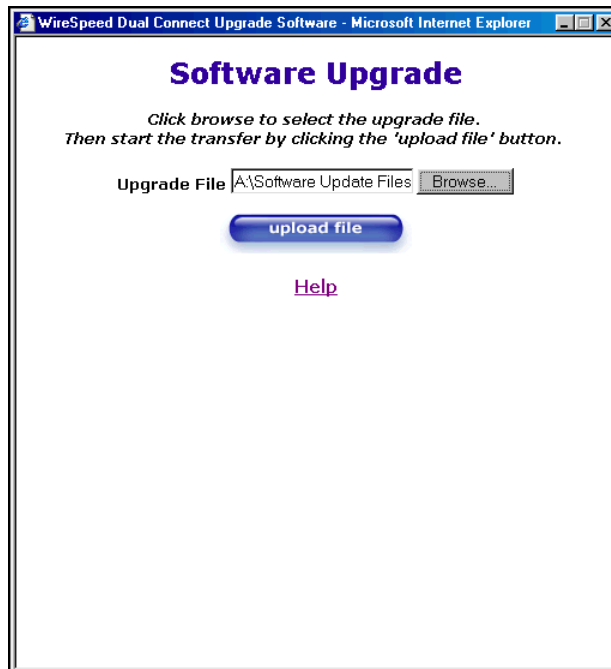

This screen shows that the file is being uploaded to VersaLink.

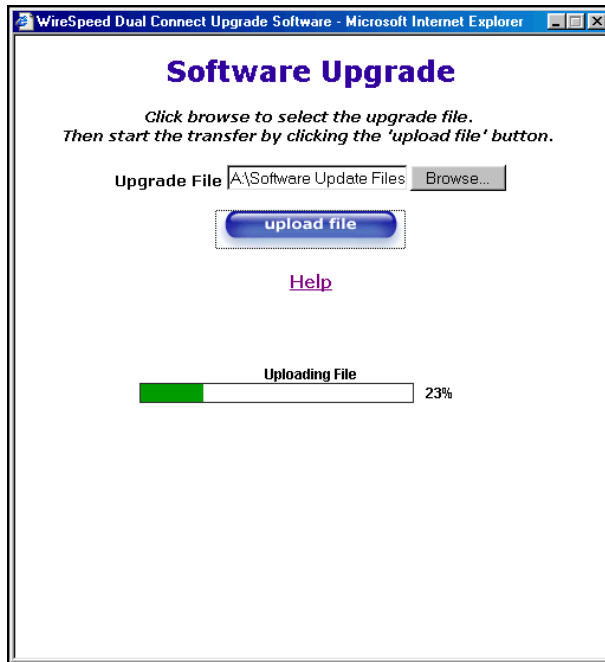

The screens below show that the file upload has completed and that the Programming Flash is being erased to prepare the Flash storage area for upload of the new file. (Programming Flash is a temporary storage area for uploaded files.)

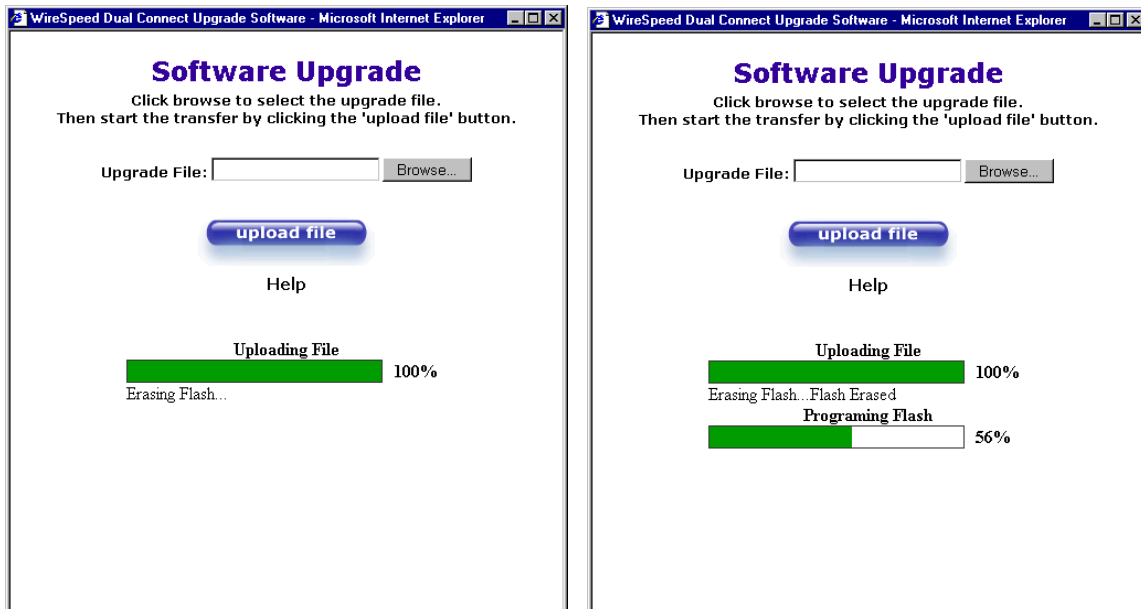

The screen below shows that the upload was successful. The Gateway will not reboot.

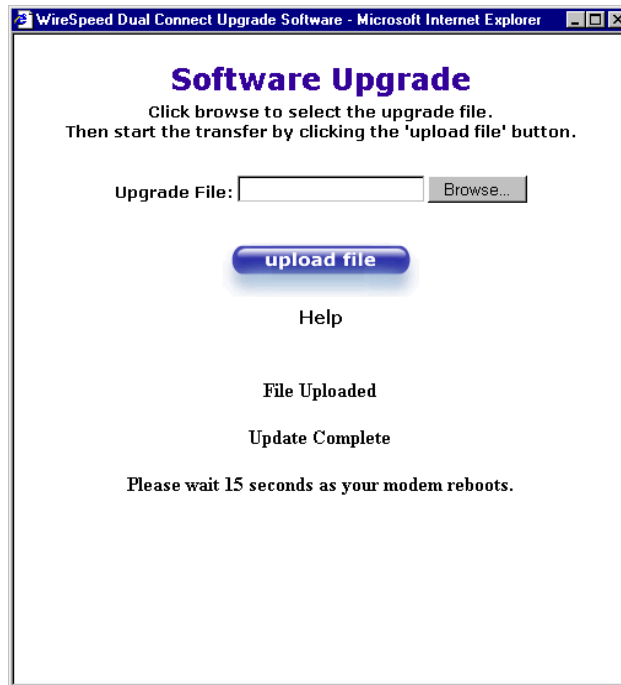

The following screen will be displayed as VersaLink is being reset.

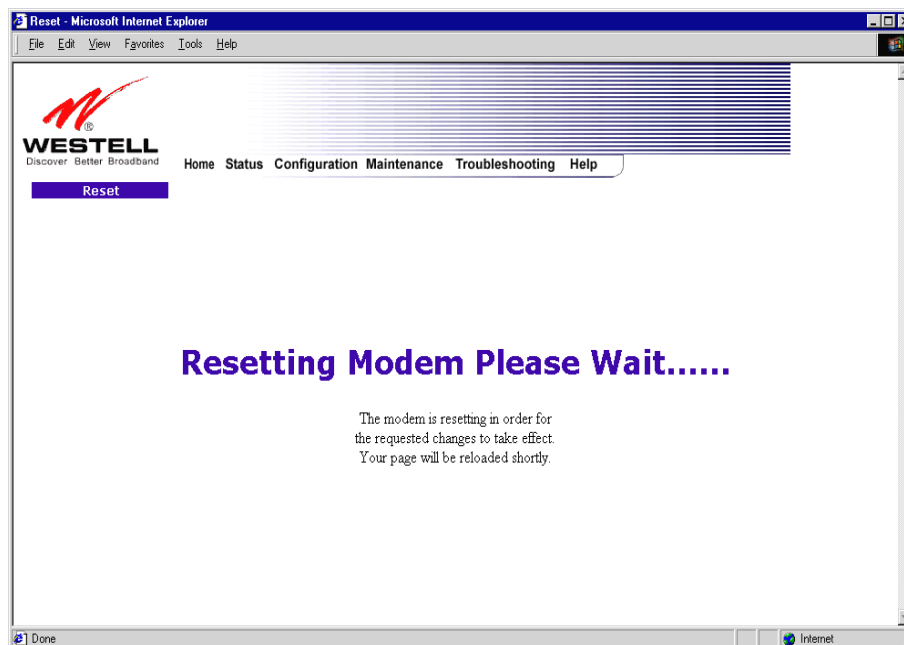

After a brief delay, the home page will be displayed. Confirm that you have a DSL sync and that the PPP Status displays **UP**. (Click on the **reset** button to re-establish your PPP session.)

15. TROUBLESHOOTING

NOTE: Options in the **Troubleshooting** menu may or may not be displayed depending on VersaLink's WAN Configuration (DSL/ATM PORT or ETHERNET PORT 1). However, all menu options are displayed if VersaLink is configured for DSL/ATM PORT 1. The following sections provide further details on the Troubleshooting menu.

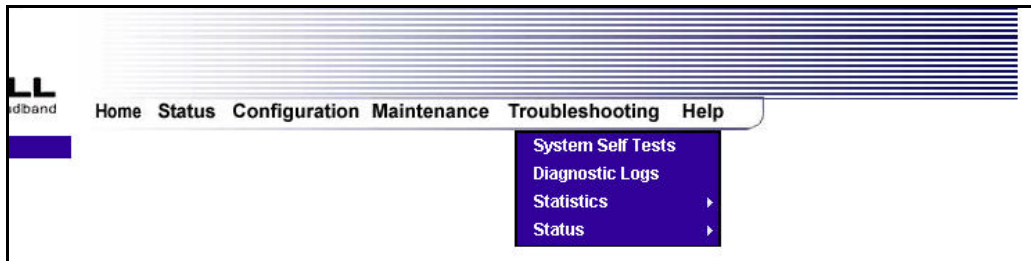

15.1 System Self Tests

The following settings will be displayed if you select **System Self Tests** from the **Troubleshooting** menu. Click on **test all** to run a diagnostic test on VersaLink's connection.

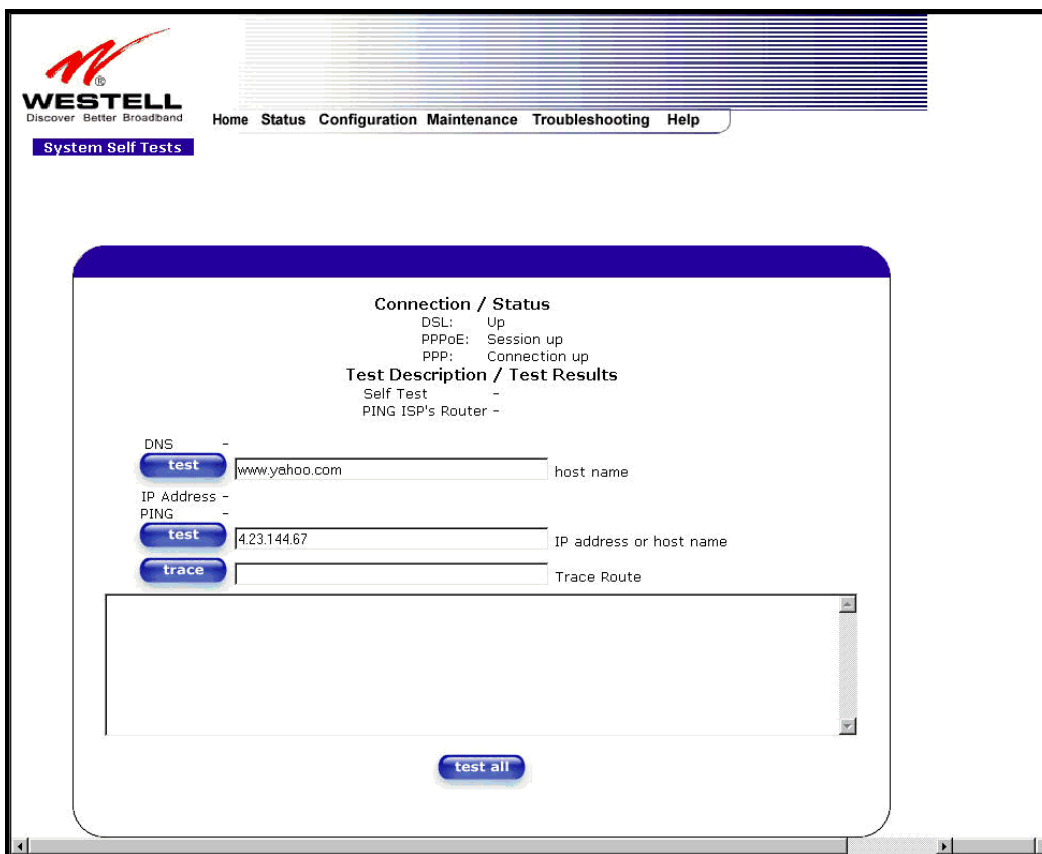

If you want to PING using the System Self Test screen (diagnostics page) shown above, enter your **DNS** or **IP** address in the fields provided and click on the **test** button. The System Self Test will run a diagnostic test that executes independent of firewall security settings. See the following table for test descriptions and possible responses.

If you want to PING using the MS-DOS (shell) window, first you will need to check your firewall security setting. (If you PING via DOS shell you are susceptible to firewall rules, as this PING is dependent on VersaLink's firewall settings.) If your firewall is set to **Medium** or **High**, you will not be able to PING. You must set your firewall security setting to **Low** or **None**.

Connection/Status	
DSL	<p>VersaLink checks the status of the DSL connection.</p> <p>Possible responses are: UP: VersaLink is operating correctly and has obtained synchronization with the opposing network device. DOWN: VersaLink is operating correctly, but has not synchronized with the opposing device.</p>
PPPoE	<p>Indicates that a PPPoE session is or is not established.</p> <p>Possible responses are: Session UP: A valid PPPoE session has been detected. No Session: Currently there is no active PPPoE session established. Initiating Session: A PPP session must be connected from the homepage screen.</p>
PPP	<p>Indicates that a PPPoE or PPPoA session must already be established.</p> <p>Possible responses are: Connection UP: VersaLink has established a connection No Connection: There is no PPP connection Initiating Connection: The PPP connection process has been initiated Connection Halted: A successful PPP connection was halted Cannot Connect: A PPP connection could not be made because of a PPPoE session failure. Authorization Failure: The user name or password is incorrect. Link Control Protocol Failed: Re-establish the session (from the home page).</p>
Test Description / Test Results	
Self Test	<p>Performs an integrity check of certain internal components of VersaLink.</p>
PING ISP's VersaLink	<p>Performs an IP network check (i.e., an IP Ping) of the Service Provider's VersaLink. This test verifies that VersaLink can exchange IP traffic with an entity on the other side of the DSL line.</p> <p>Possible responses are: Success: VersaLink has detected an IP Remote VersaLink connection. No Response: The IP Remote VersaLink does not answer the IP Ping. Could not test: The test could not be executed due to VersaLink settings. Check your DSL sync or your PPP session. You must have both a DSL sync and a PPP connection established to execute a PING.</p>
DNS	<p>Performs a test to try to resolve the name of a particular host. The host name is entered in the input box.</p> <p>Possible responses are: Success: VersaLink has successfully obtained the resolved address. The IP address is shown below the host name input box. No Response: VersaLink has failed to obtain the resolved address.</p>

	<p>Host not found: The DNS Server was unable to find an address for the given host name.</p> <p>No data, enter host name: No host name is specified.</p> <p>Could not test: The test could not be executed due to VersaLink settings. Check your DSL sync or your PPP session. You must have both a DSL sync and a PPP connection established to execute a PING.</p>
IP Address	IP Address of the Host Name.
PING (via IP Address or Host Name)	<p>Performs an IP connectivity check to a remote computer either within or beyond the Service Provider's network. You can PING a remote computer via the IP address or the DNS address. If your PING fails, try a different IP or DNS address.</p> <p>Possible responses are:</p> <p>Success: The Remote Host computer was detected.</p> <p>No Response: There was no response to the Ping from the remote computer.</p> <p>No name or address to PING: No host name or IP address was specified.</p> <p>Could not test: The test could not be executed due to VersaLink settings. Check your DSL sync or your PPP session. You must have both a DSL sync and a PPP connection established to execute a PING.</p>
Trace	<p>Determines the route taken to destination by sending Internet Control Message Protocol (ICMP) echo packets with varying IP Time-To-Live (TTL) values to the destination. Trace Route is used to determine where the packet is stopped on the network.</p>

15.2 Diagnostic Logs

If you select **Diagnostic Log**, from the **System Self Test** menu, the following screen will be displayed.

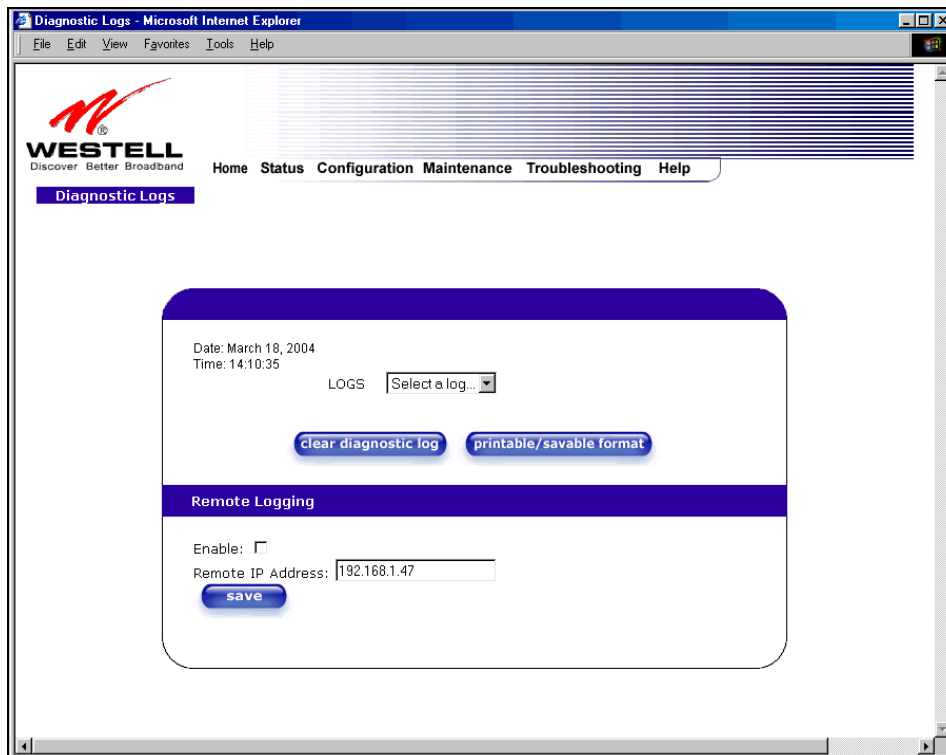

To see a list of the log options, click on the arrow at the **LOGS** drop-down menu. Select an option from the list provided at the **Diagnostics Logs** screen.

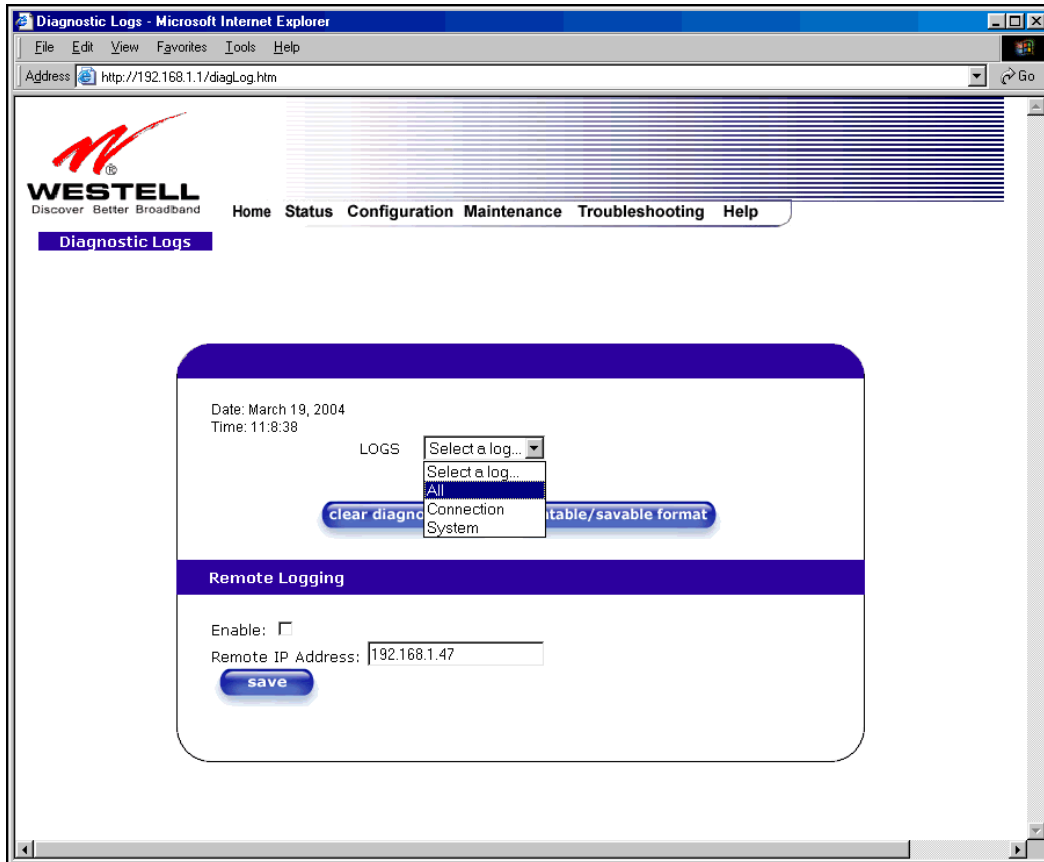

If you clicked on **All**, the following screen will be displayed. This screen provides a detailed list of VersaLink's connection status and system information. Click on **clear diagnostic log** to clear the diagnostic log information.

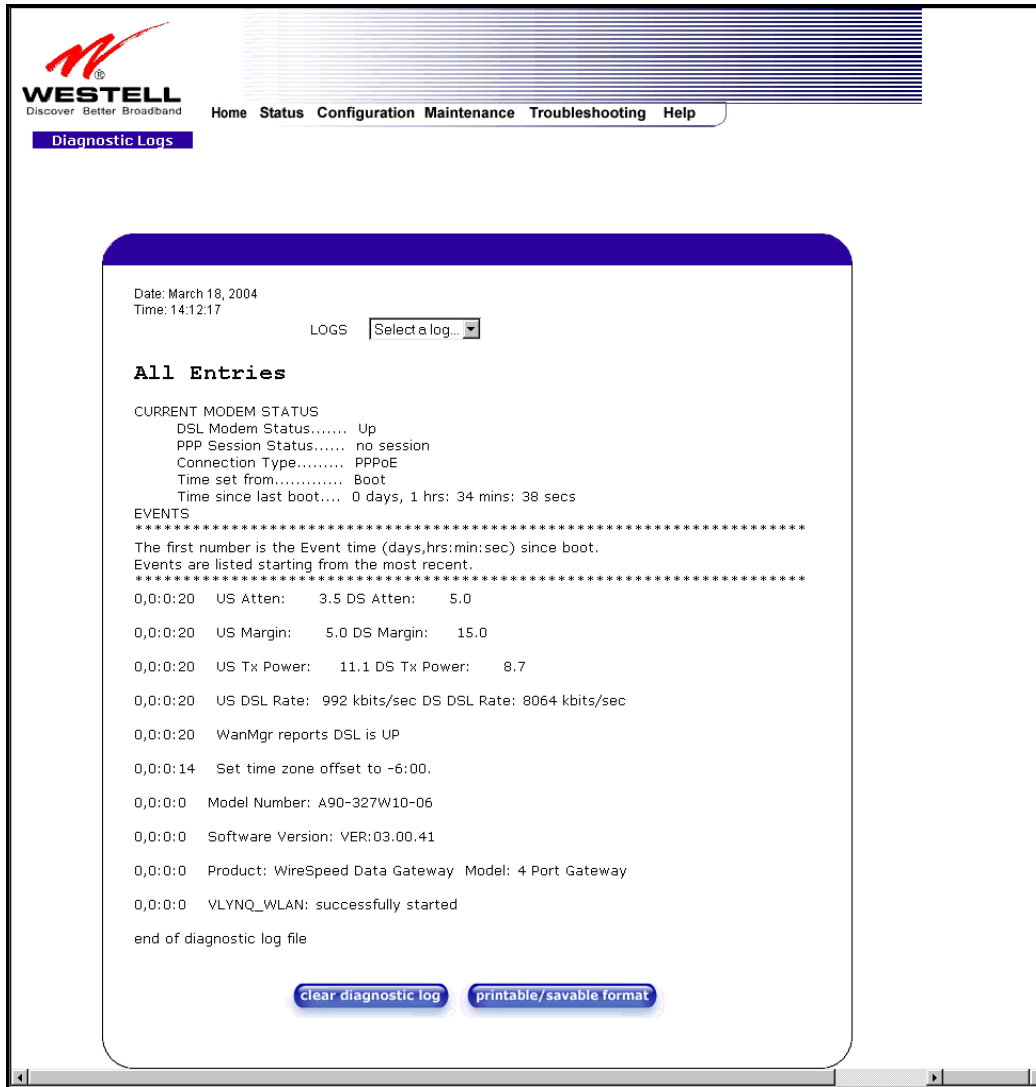

The screenshot shows the Westell Diagnostic Logs web interface. At the top left is the Westell logo and tagline. A navigation menu includes Home, Status, Configuration, Maintenance, Troubleshooting, and Help. The 'Diagnostic Logs' link is highlighted. The main content area shows the date and time (March 18, 2004, 14:12:17) and a 'LOGS' dropdown menu set to 'Select a log...'. Below this is the 'All Entries' section, which displays the current modem status and a list of events. The modem status shows DSL Modem Status as 'Up', PPP Session Status as 'no session', and Connection Type as 'PPPoE'. The events list includes DSL rates, power levels, and system messages. At the bottom of the log area are two buttons: 'clear diagnostic log' and 'printable/savable format'.

WESTELL
Discover Better Broadband

Home Status Configuration Maintenance Troubleshooting Help

Diagnostic Logs

Date: March 18, 2004
Time: 14:12:17

LOGS:

All Entries

CURRENT MODEM STATUS
DSL Modem Status..... Up
PPP Session Status..... no session
Connection Type..... PPPoE
Time set from..... Boot
Time since last boot.... 0 days, 1 hrs: 34 mins: 38 secs

EVENTS

The first number is the Event time (days,hrs:min:sec) since boot.
Events are listed starting from the most recent.

0,0:0:20 US Atten: 3.5 DS Atten: 5.0

0,0:0:20 US Margin: 5.0 DS Margin: 15.0

0,0:0:20 US Tx Power: 11.1 DS Tx Power: 8.7

0,0:0:20 US DSL Rate: 992 kbits/sec DS DSL Rate: 8064 kbits/sec

0,0:0:20 WanMgr reports DSL is UP

0,0:0:14 Set time zone offset to -6:00.

0,0:0:0 Model Number: A90-327W10-06

0,0:0:0 Software Version: VER:03.00.41

0,0:0:0 Product: WireSpeed Data Gateway Model: 4 Port Gateway

0,0:0:0 VLYNQ_WLAN: successfully started

end of diagnostic log file

15.2.1 Saving the Diagnostic Log File

If you want to save the diagnostic log file, go to your Browser's menu and select **File**, then select **Save As** from the drop-down menu.

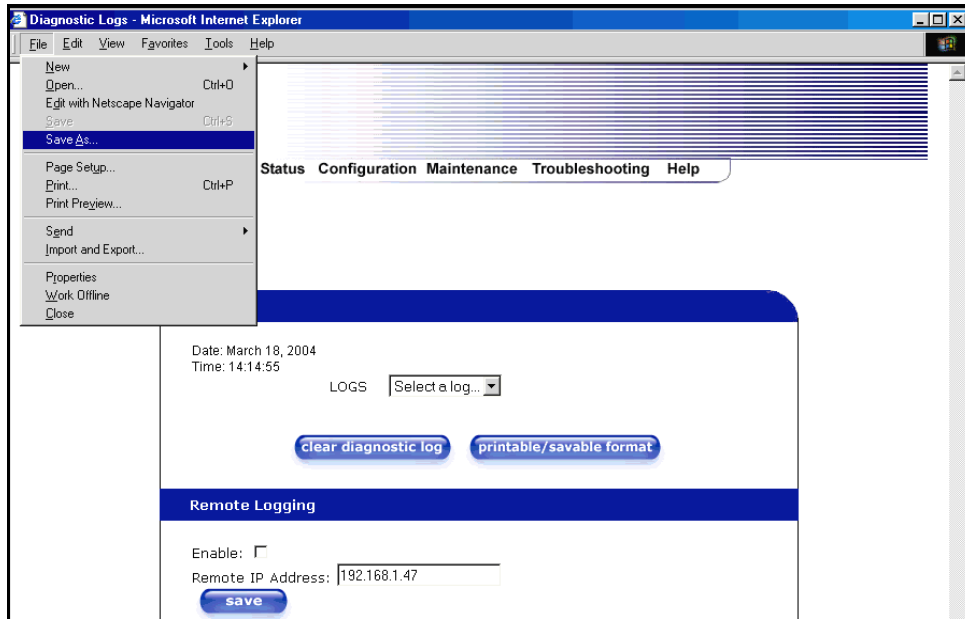

At the **Save Web Page** dialog box, select a destination for your log file from the **Save in** drop-down arrow. Next, enter a name for your log file in the field labeled **File name** and click on **Save**.

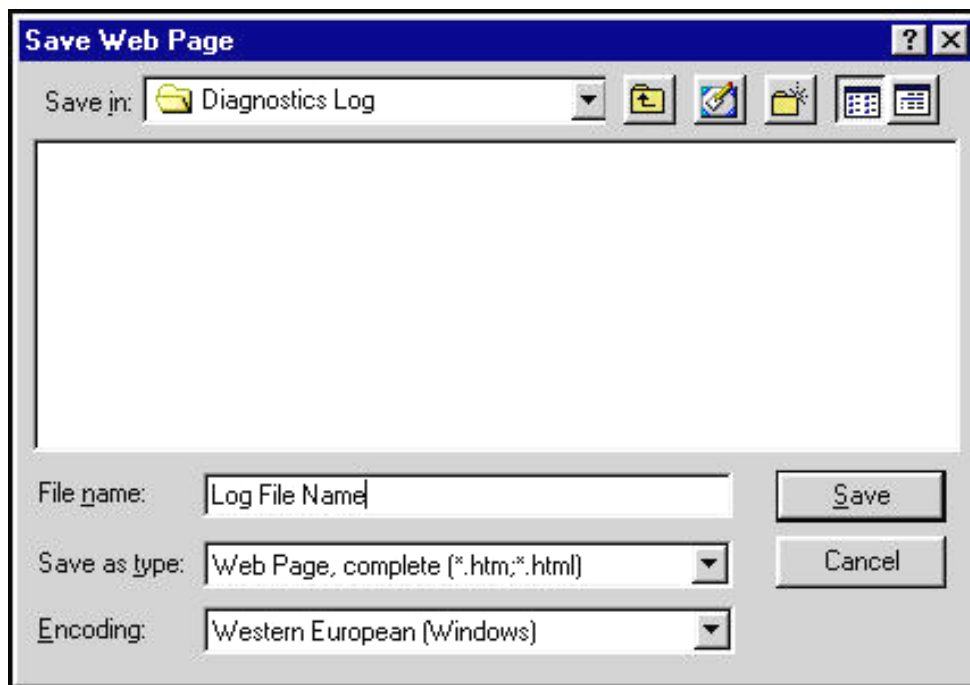

15.3 Statistics

NOTE: If VersaLink is configured for **ETHERNET PORT 1**, only **Ethernet** and **Wireless** statistics will be displayed in the **Statistics** menu. The **DSL Transceiver** statistics and the **WAN VC** statistics will not be displayed. If you want to view **DSL Transceiver** and **WAN VC** statistics, you must configure VersaLink for **DSLATM PORT**. Refer to section 12.6.2.1 for additional details.

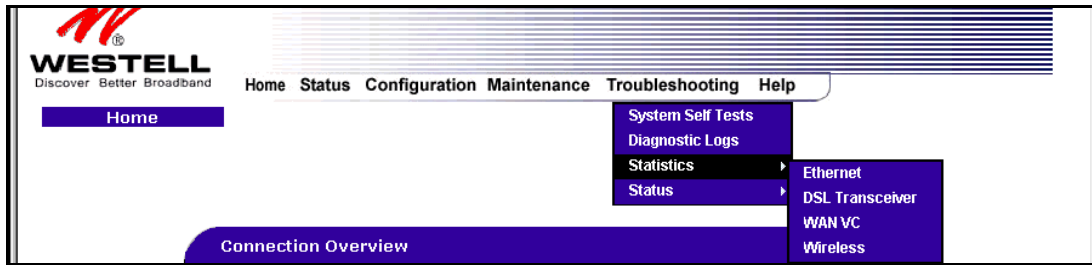

15.3.1 Ethernet Port Statistics

The following settings will be displayed if you select **Ethernet** from the **Statistics** menu.

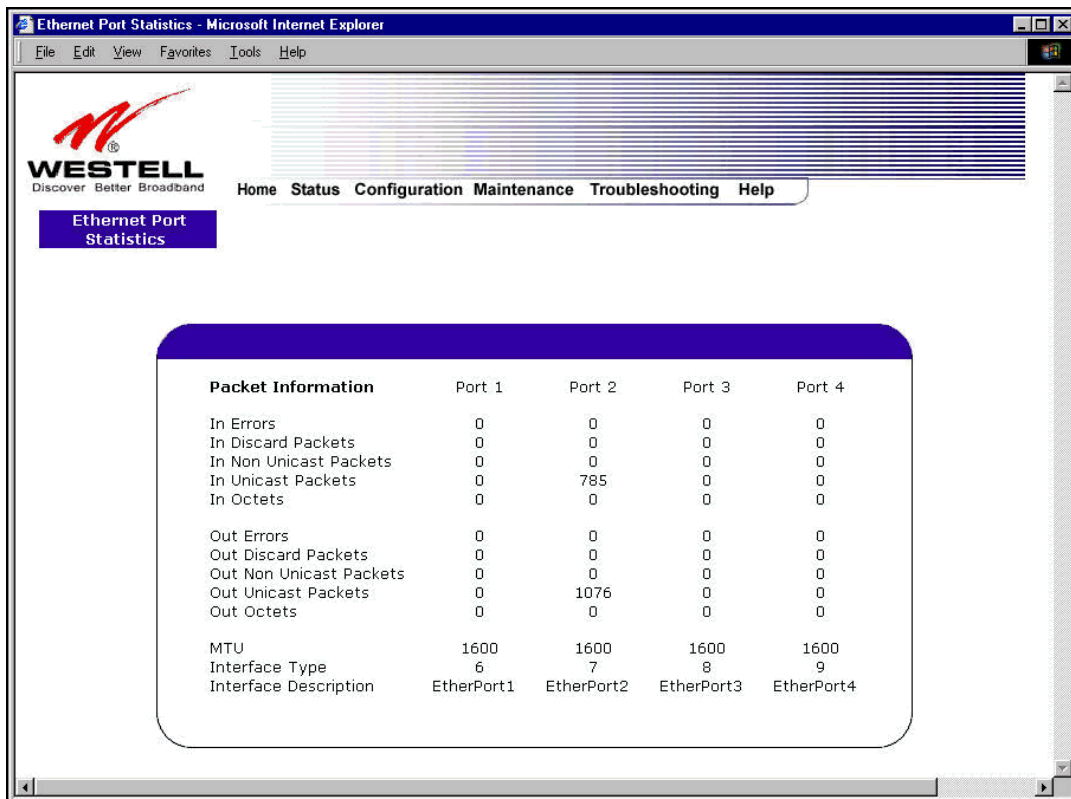

The screenshot shows the 'Ethernet Port Statistics' page in a Microsoft Internet Explorer browser window. The page displays a table of statistics for four ports (Port 1, Port 2, Port 3, and Port 4).

Packet Information	Port 1	Port 2	Port 3	Port 4
In Errors	0	0	0	0
In Discard Packets	0	0	0	0
In Non Unicast Packets	0	0	0	0
In Unicast Packets	0	785	0	0
In Octets	0	0	0	0
Out Errors	0	0	0	0
Out Discard Packets	0	0	0	0
Out Non Unicast Packets	0	0	0	0
Out Unicast Packets	0	1076	0	0
Out Octets	0	0	0	0
MTU	1600	1600	1600	1600
Interface Type	6	7	8	9
Interface Description	EtherPort1	EtherPort2	EtherPort3	EtherPort4

In Errors	The number of error packets received on the Ethernet interface.
In Discard Packets	The number of discarded packets received.

In Non Unicast Packets	The number of non-Unicast packets received on the Ethernet interface.
In Unicast Packets	The number of Unicast packets received on the Ethernet interface.
In Octets	The number of bytes received on the Ethernet interface.
Out Errors	The number of outbound packets that could not be transmitted due to errors.
Out Discard Packets	The number of outbound packets discarded.
Out Non Unicast Packets	The number of non-Unicast packets transmitted on the Ethernet interface.
Out Unicast Packets	The number of Unicast packets transmitted on the Ethernet interface.
Out Octets	The number of bytes transmitted on the Ethernet interface.
MTU	Maximum Transmission Unit- The number of data bytes contained in the Ethernet frame.
Interface Type	A unique identifier that represents the interface type.
Interface Description	A description field that refers to the interface type.

15.3.2 DSL Transceiver Statistics

The following settings will be displayed if you select **DSL Transceiver** from the **Statistics** menu.

NOTE: If VersaLink is configured using **ETHERNET PORT 1**, the following screen will not be available.

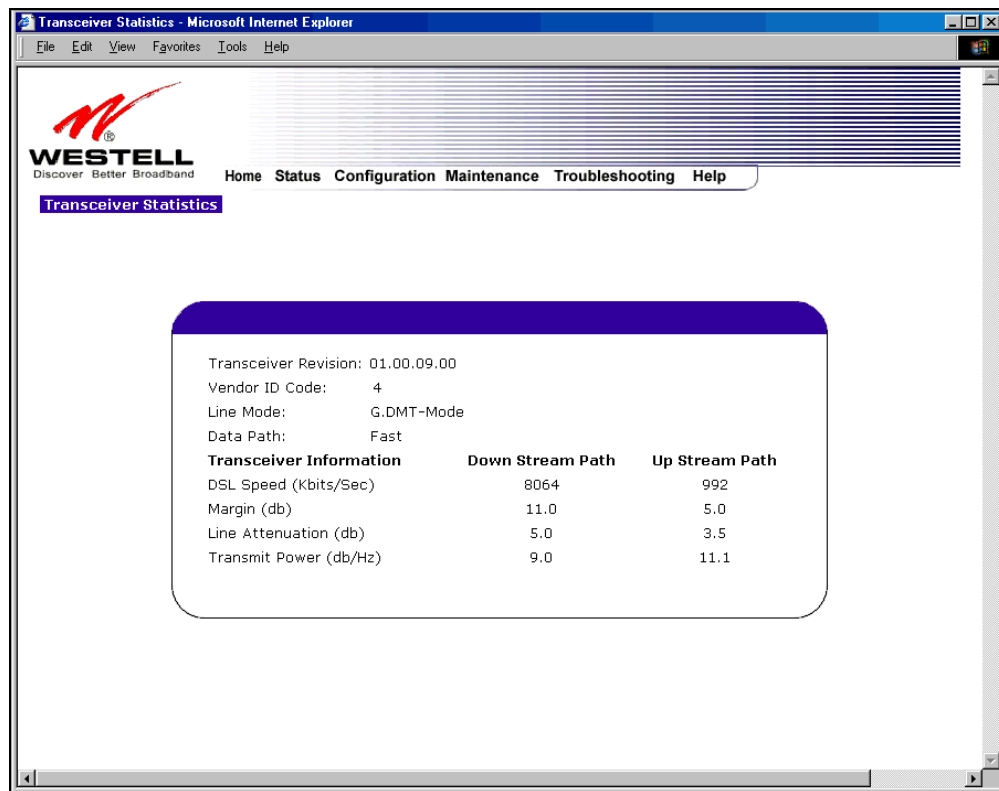

Transceiver Revision	The transceiver software version number.
Vendor ID Code	The CPE Vendor's ID code for their chipset.
Line Mode	The operational mode. Modes supported are No Mode, Multi Mode, T.1413 Mode, G.DMT Mode, and G.LITE Mode.
Data Path	The data path used (either Fast or Interleaved).
Transceiver Information-Down Stream/Up Stream Path	
DSL Speed (Kbits/Sec)	The transmission rate that is provided by your Internet Service Provider (ISP).

SNR Margin (db)	The Signal-to-Noise Ratio (S/N) where 0 db = 1×10^{-7} , which inhibits your DSL speed.
Line Attenuation (dB)	The DSL line loss.
Transmit Power (db/Hz)	The transmitted signal strength.

15.3.3 WAN VC Statistics

The following settings will be displayed if you select **WAN VC** from the **Statistics** menu.

NOTE: If VersaLink is configured using **ETHERNET PORT 1**, the following screen will not be available.

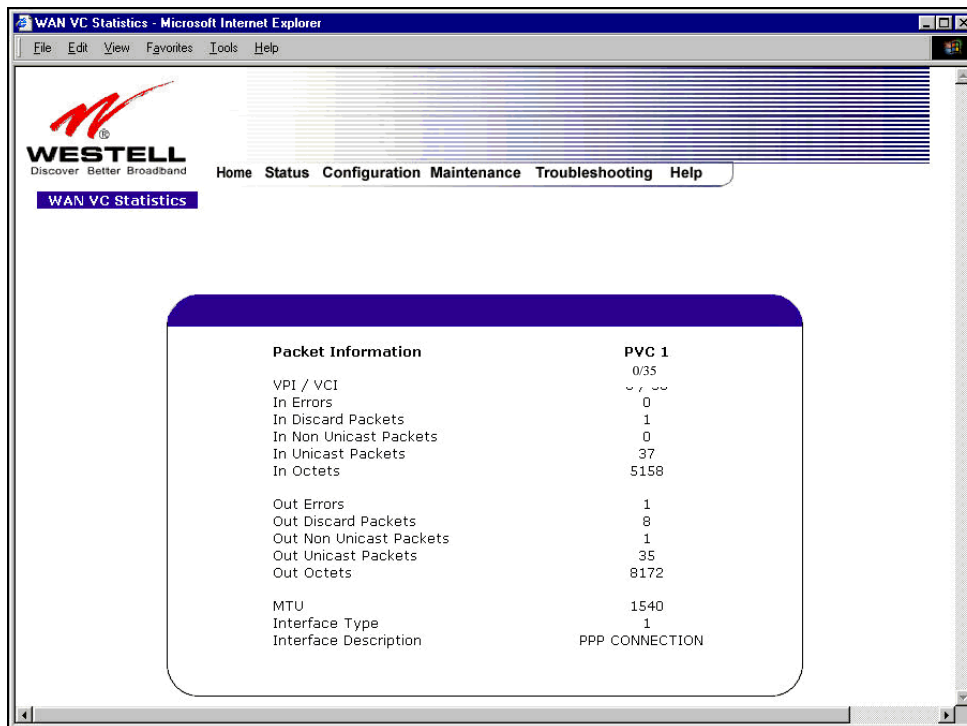

VPI/VCI	Displays the VPI/VCI values obtained from your Internet Service Provider.
In Errors	The number of error packets received on the ATM port.
In Discard Packets	The number of discarded packets received.
In Non Unicast Packets	The number of non-Unicast packets received on the ATM port.
In Unicast Packets	The number of Unicast packets received on the ATM port.
In Octets	The number of bytes received on the ATM port.
Out Errors	The number of outbound packets that could not be transmitted due to errors.
Out Discard Packets	The number of outbound packets discarded.
Out Non Unicast Packets	The number of non-Unicast packets transmitted on the ATM port.
Out Unicast Packets	The number of Unicast packets transmitted on the ATM port.
Out Octets	The number of bytes transmitted on the ATM port.
MTU	Maximum Transmission Unit -The number of data bytes contained in the ATM frame.
Interface Type	A unique identifier that represents the interface type.
Interface Description	A description field that refers to the interface type.

15.4 Wireless Statistics

The following settings will be displayed if you select **Wireless** from the **Statistics** menu.

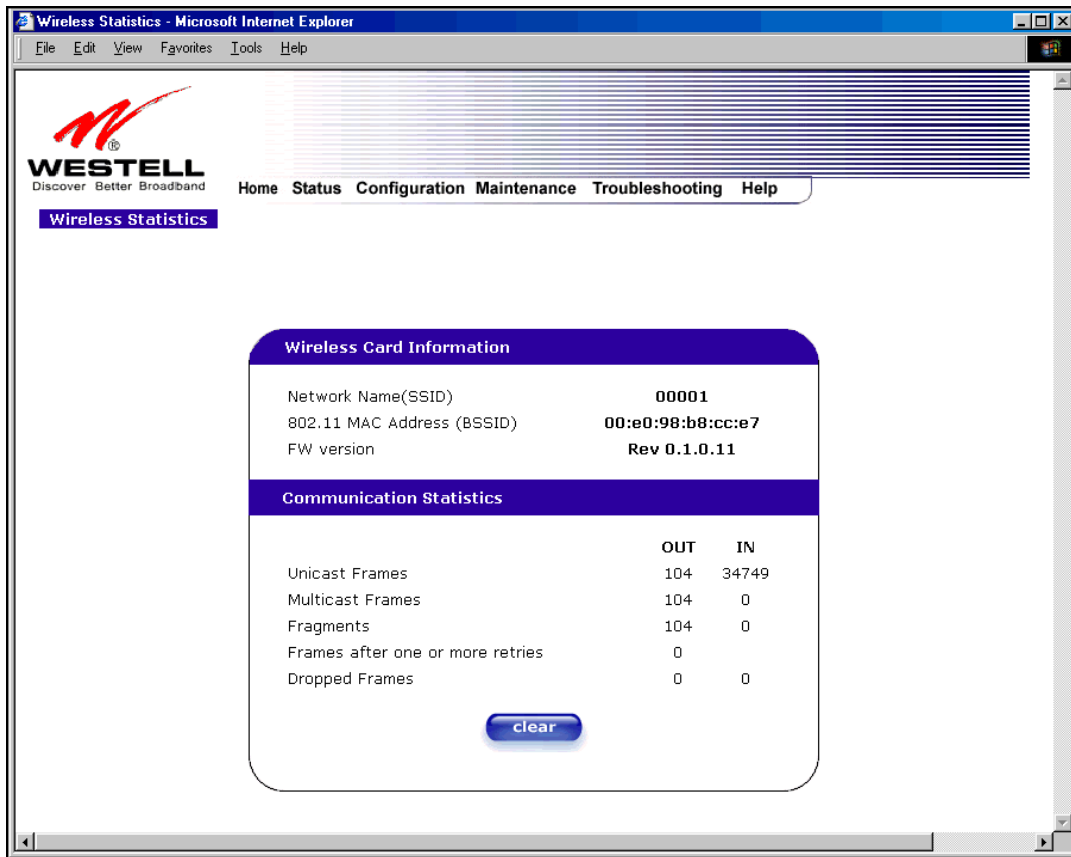

Wireless Card Information	
Network Name (SSID)	This string, (32 characters or less) is the name associated with the Access Point (AP). To connect to the AP, the Service Set ID (SSID) on a Station card must match the SSID on the AP.
802.11 MAC Address (BSSID)	This is the Media Access Controller address of the AP. It is used as the Basic Service Set Identifier (BSSID).
FW Version	This is the Network Interface Card Identifier. It uniquely identifies the hardware platform of the AP. This is used with other information to determine if the inserted card can be used as an AP, and if so, the version of AP firmware to be used. Not all makes of wireless station cards can be used as an AP.
Communication Statistics	
NOTE: Data preceded by OUT pertain to transmissions from the VersaLink to a station; VersaLink is the source. Data preceded by IN pertain to data received by VersaLink; VersaLink is the destination.	
OUT-Unicast Frames	The number of successfully transmitted frames whose destination address was a single station; not necessarily the same station, but to any single station as opposed to a transmission that multiple stations would receive-as in the case of broadcast message.

OUT-Multicast Frames	The number of successfully transmitted frames whose destination address was a multicast address (received by more than one station): not necessarily broadcast to all stations, but more than a single station. Broadcast messages are included in the count.
OUT-Fragments	The number of successful transmissions made. This will typically be greater than the sum of the Unicast and Multicast frames because large frames are broken into multiple transmissions. The number of fragments per frame is based on the Fragmentation Threshold setting (not user-configurable).
OUT-Frames after one or more retries	The number of frames that successfully transmitted after more than one retry. Any fragment of a frame that required multiple retries would increment this counter for the whole frame.
OUT-Dropped Frames, too many retries	The number of frames that did not transmit due to the short or long retry limit being reached because no acknowledgement or CTS was received.
IN-Unicast Frames	The number of successfully received frames whose destination address was a single location, not necessarily the same location, but to any single location as opposed to the broadcast address.
IN-Multicast Frames	The number of successfully received frames whose destination address was a multicast address. Broadcast messages are included in this count.
IN-Fragments	The number of fragments successfully received. This may not be equal to the sum of the Unicast and Multicast frames because large frames are broken into multiple transmissions. The number of fragments per frame is based on the Fragmentation Threshold setting (not user-configurable) on the source station.
IN-Frames after one or more retrie	The number of frames that successfully transmitted after more than one retry. Any fragment of a frame that required multiple retries would increment this counter for the whole frame.
IN-Drops due to insufficient Rx buffers	The number of received frames discarded due to lack of buffer space.

15.5 Status

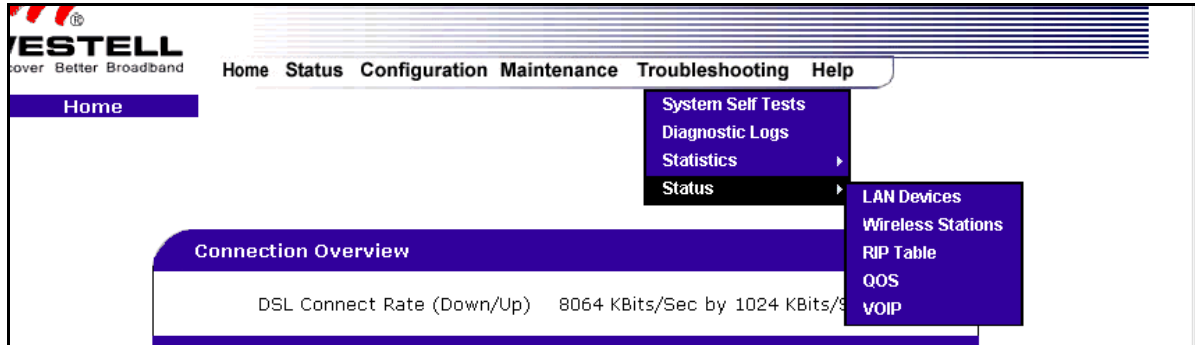

15.5.1 LAN Devices

The following settings will be displayed if you select **LAN Devices** from the **Status** menu.

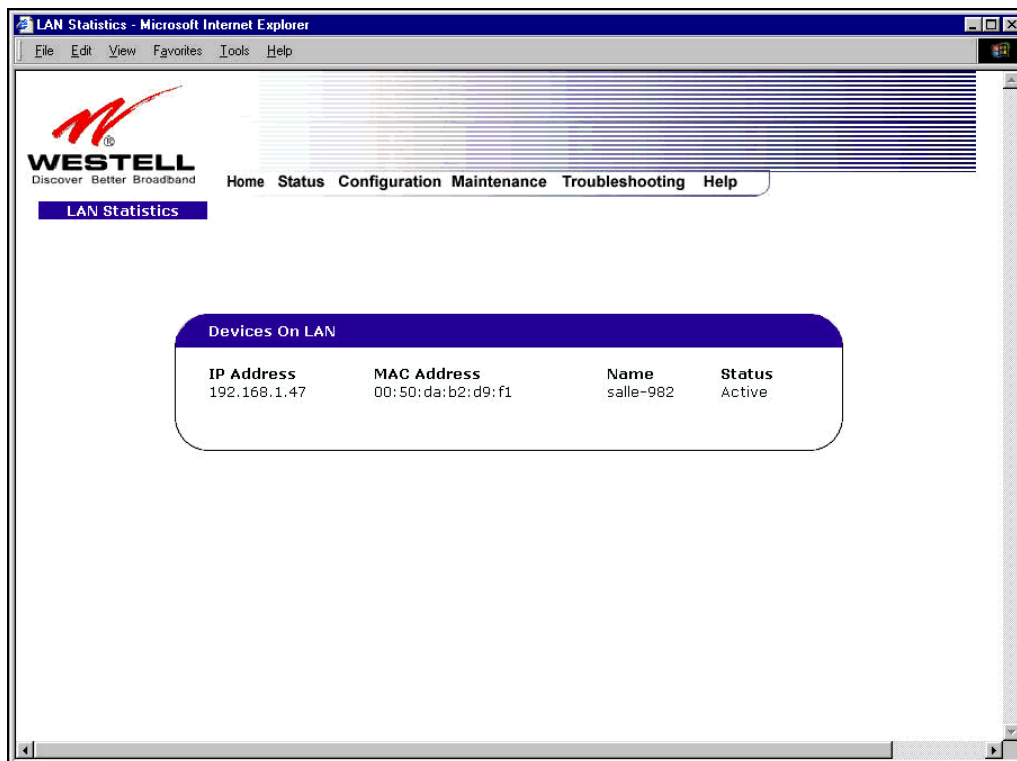

Devices on LAN	
IP Address	Displays the IP network address that VersaLink is on.
MAC Address	Media Access Controller (MAC) address of this device.
Name	Displays the ASCII (text) name of the devices connected to the LAN.
Status	Displays the status of the devices connected to the LAN.

15.5.2 Wireless Stations

The following settings will be displayed if you select **Wireless** from the **Status** menu.

NOTE: A Wireless device must be connected to the Gateway for the fields in this screen to be populated.

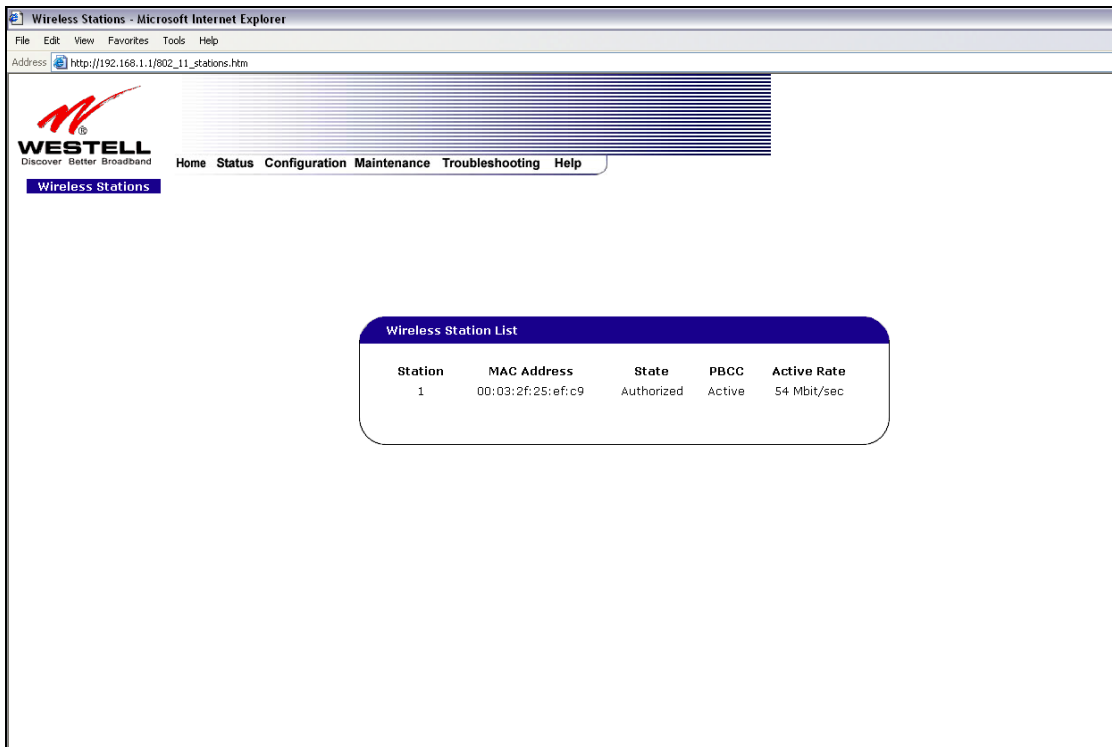

Wireless Stations List	
Station	This number indicates the order in which the stations are first accessed by VersaLink.
MAC Address	The Media Access Controller Address assigned to the station.
State	The current state of the negotiation between the station and VersaLink.
PBCC	Indicates whether the station that is associated with VersaLink operates in PBCC (Packet Binary Convolutional Code) modulation.
Active Rate	The current transmit and receive rate.

15.5.3 RIP Table

The following settings will be displayed if you select **RIP Table** from the **Status** menu.

NOTE: RIP must be enabled for this table to be populated.

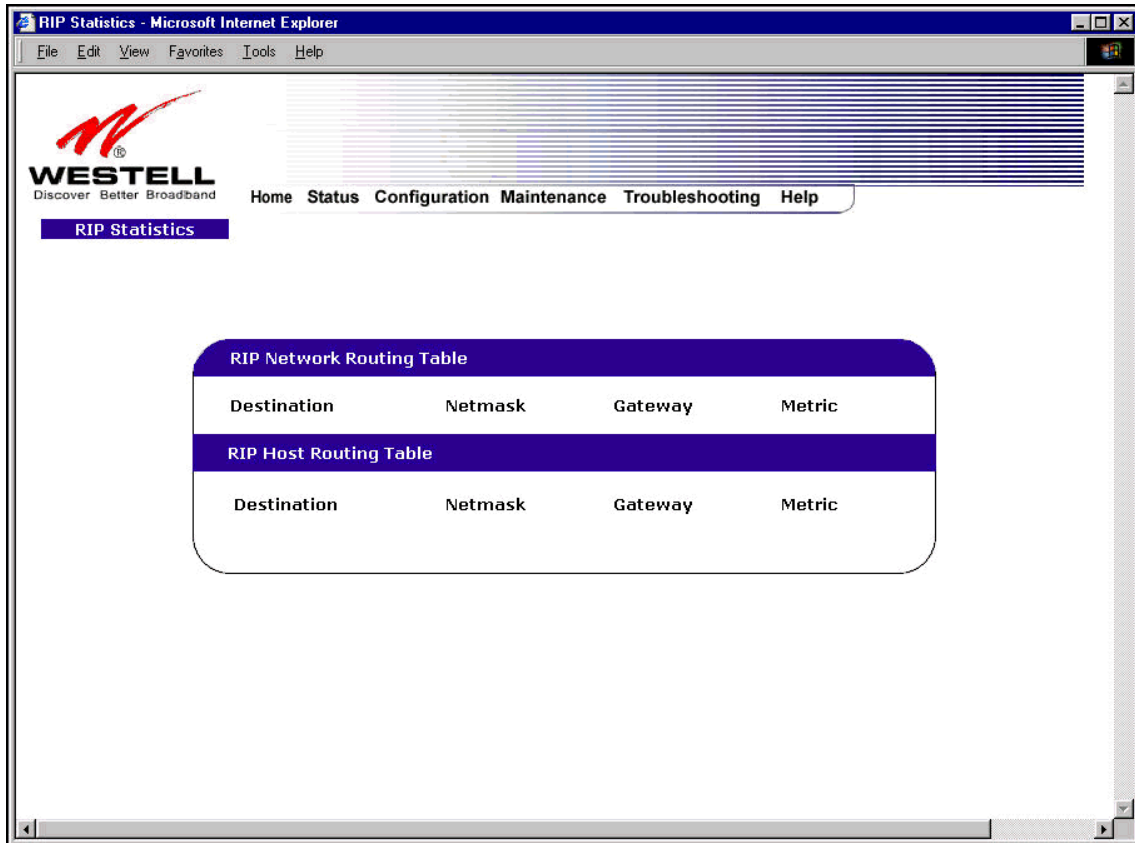

RIP Network Routing Table	Indicates Network routes received via RIP.
RIP Host Routing Table	The Host routes received via RIP.
Destination	The destination IP address of the route
Netmask	The IP mask of the route
Gateway	The gateway of the route
Metric	The RIP metric (0-15). A lower value is better.

15.5.4 QOS Status

The following settings will be displayed if you select **QOS** from the **Status** menu. Click on the **clear** button to clear all counts and statistics (not just latency counts). This does not affect the configuration values.

NOTE: QoS must be enabled on the Gateway for this table to be populated.

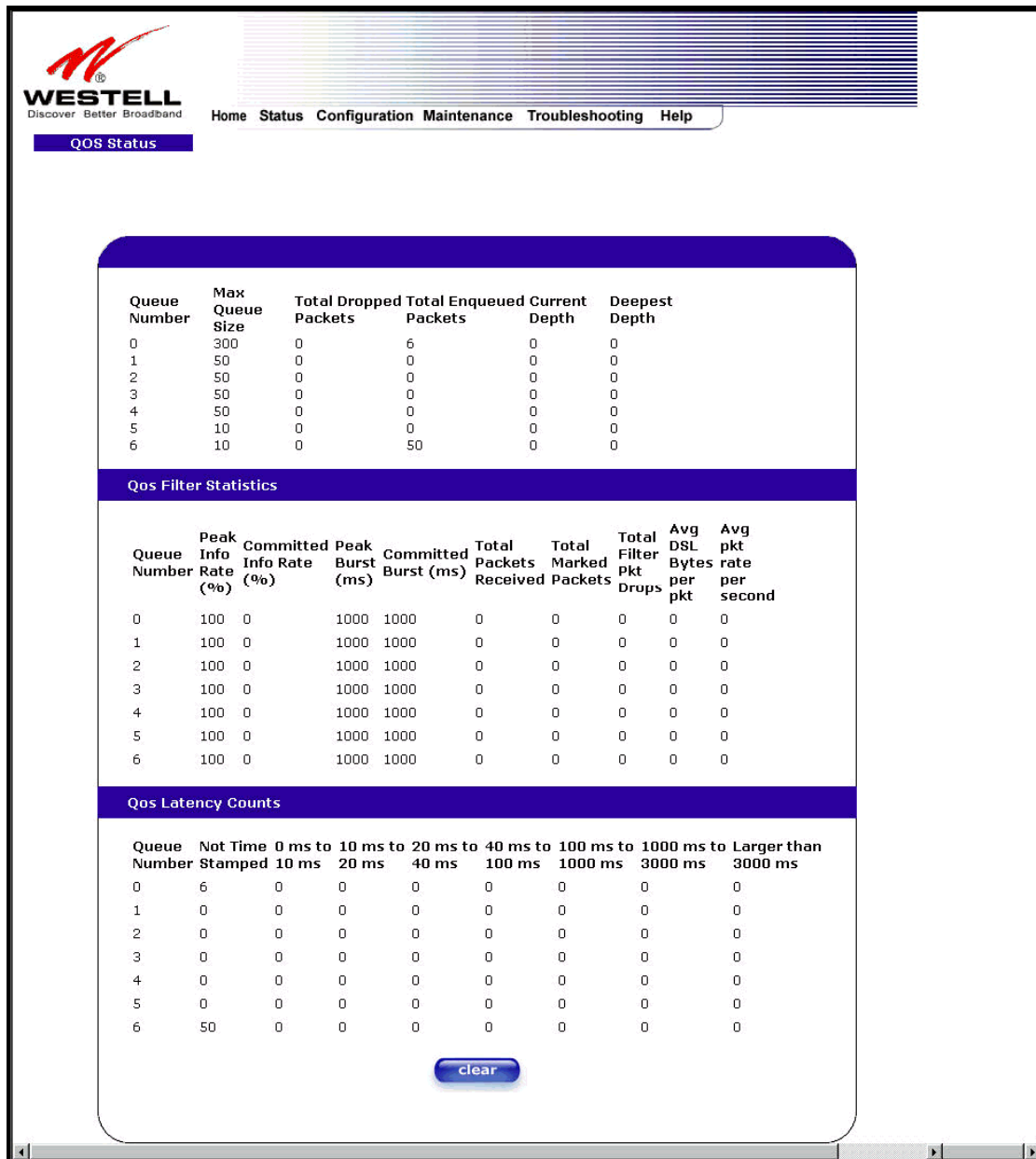

WESTELL
Discover Better Broadband

Home Status Configuration Maintenance Troubleshooting Help

QOS Status

Queue Number	Max Queue Size	Total Dropped Packets	Total Enqueued Packets	Current Depth	Deepest Depth
0	300	0	6	0	0
1	50	0	0	0	0
2	50	0	0	0	0
3	50	0	0	0	0
4	50	0	0	0	0
5	10	0	0	0	0
6	10	0	50	0	0

Qos Filter Statistics

Queue Number	Peak Info Rate (%)	Committed Info Rate (%)	Peak Burst (ms)	Committed Burst (ms)	Total Packets Received	Total Marked Packets	Total Filter Pkt Drops	Avg DSL Bytes per pkt	Avg pkt rate per second
0	100	0	1000	1000	0	0	0	0	0
1	100	0	1000	1000	0	0	0	0	0
2	100	0	1000	1000	0	0	0	0	0
3	100	0	1000	1000	0	0	0	0	0
4	100	0	1000	1000	0	0	0	0	0
5	100	0	1000	1000	0	0	0	0	0
6	100	0	1000	1000	0	0	0	0	0

Qos Latency Counts

Queue Number	Not Stamped	Time 0 ms to 10 ms	10 ms to 20 ms	20 ms to 40 ms	40 ms to 100 ms	100 ms to 1000 ms	1000 ms to 3000 ms	3000 ms to Larger than 3000 ms
0	6	0	0	0	0	0	0	0
1	0	0	0	0	0	0	0	0
2	0	0	0	0	0	0	0	0
3	0	0	0	0	0	0	0	0
4	0	0	0	0	0	0	0	0
5	0	0	0	0	0	0	0	0
6	50	0	0	0	0	0	0	0

clear

Queue Number	Indicates the DiffServ Queue. Possible responses are: 0 = Best Effort (BE) 1 = Assured Forwarding 1 (AF1) 2 = Assured Forwarding 2 (AF2) 3 = Assured Forwarding 2 (AF3) 4 = Assured Forwarding 2 (AF4) 5 = Expedited Forwarding (EF) 6 = Routing Protocols (DiffServ priorities 6 and 7)
Max Queue Size	The maximum number of packets that can be queued for this priority.
Total Dropped Packets	Indicates how many packets of this priority have been dropped by QOS due to lack of buffer space or filtering rules.
Total Enqueued Packets	Displays the number of packets, destined for the WAN, that have been received.
Current Depth	Displays the current number of packets of this priority that are queued.
Deepest Depth	Displays the most number of packets that have been queued at once for this priority.
QOS Filter Statistics	
Queue Number	The DiffServ Queue. (See Queue Number description above.)
Peak Info. Rate (%)	The maximum allowed rate for this priority, expressed as a percentage of the DSL rate.
Committed Info Rate (%)	The committed rate for this priority, expressed as a percentage of the DSL rate
Peak Burst (ms)	Displays the interval in milliseconds for averaging the peak offered rate.
Committed Burst (ms)	Displays the interval in milliseconds for averaging the committed offered rate.
Total Packets Received	Displays the total number of packets of this priority that are destined for the LAN.
Total Marked Packets	Displays the number of packets of this priority that exceeded the committed rate, but not the peak rate, and were marked with a higher drop priority
Total Filter Packet Drops	Displays the number of packets of this priority that exceeded the peak rate and that were, therefore, dropped.
Avg. DSL Bytes Per Packet	Displays the average size of packets for this priority, including all overhead.
Avg. Packet Rate Per second	Displays the average rate (in packets per seconds) for this priority.
QOS Latency Counts	
Queue Number	The DiffServ Queue. (See Queue Number description above.)
Not Time Stamped	The packets with no incoming time stamp. (Often these are generated internal to the modem.)
A ms to B ms	The number of packets of this priority whose time in the modem fell between A and B milliseconds. (Time is measured from the point the packet arrives at the modem's processor until is passed to the ATM hardware for transmission.) Possible ranges are (A ms to B ms): 0 ms to 10 ms 10 ms to 20 ms 20 ms to 40 ms 40 ms to 100 ms 100 ms to 1000 ms 1000 ms to 3000 ms Larger than 3000 ms

15.5.5 VOIP Status

The following settings will be displayed if you select **VOIP** from the **Status** menu.

NOTE: A VOIP device must be connected to the Gateway for this table to be populated.

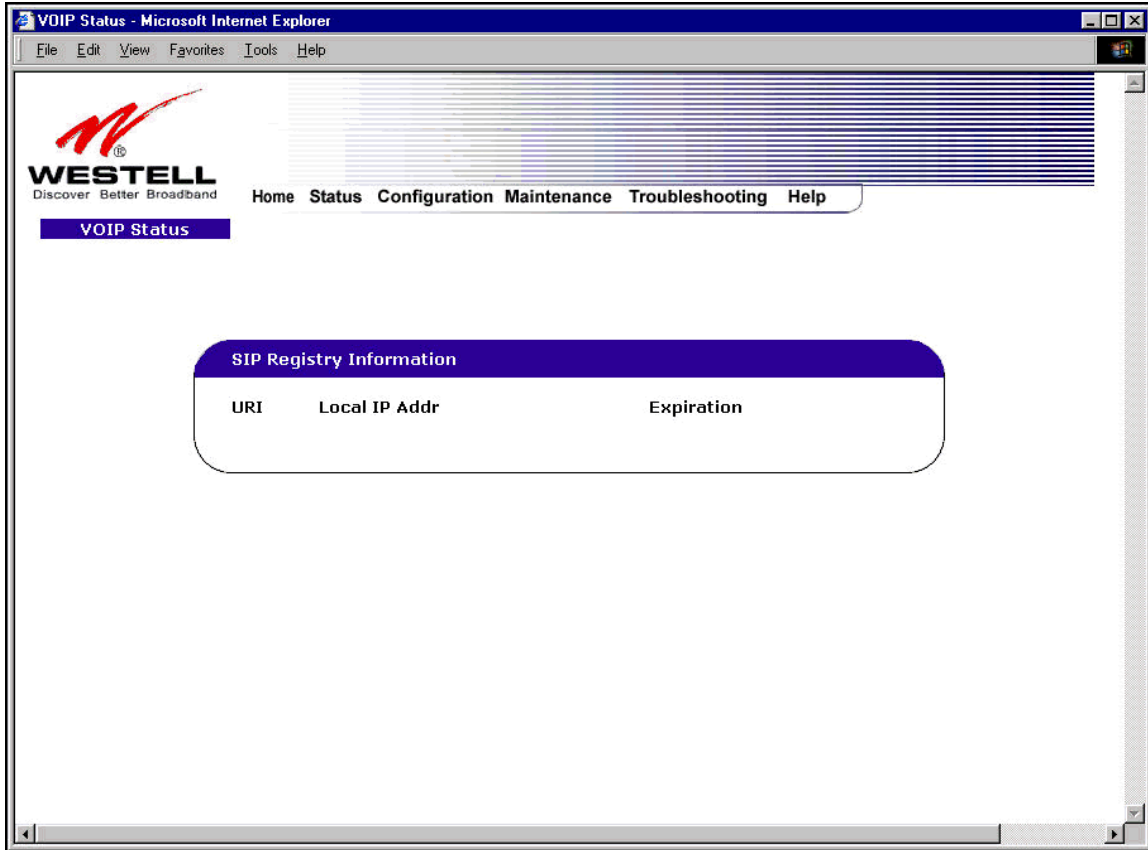

SIP Registry Information	
URI	The SIP URI that is trying to register. (This field only indicates that a SIP device tried to register, not that it succeeded.)
Local IP Address	The local, LAN IP address of the SIP device.
Expiration	Indicates how long (in seconds) until the registration expires.

16. NAT SERVICES

For your convenience, VersaLink supports protocols for Applications, Games, and VPN-specific programs. The following chart provides protocol information for the services supported by VersaLink.

NOTE: To configure VersaLink for a service or application, follow the steps in section 13 (Setting Up Advanced Service Configuration) of this User Guide.

Applications/Games/VPN Support

Application/Game	Port/Protocol
Aliens vs. Predator	80 UDP, 2300 UDP, 8000-8999 UDP
America Online	5190 TCP/UDP
AoE II: Conquors	47624 TCP/UDP, 6073 TCP/UDP, 2300-2400 TCP/UDP
AOL Instant Messenger	4099 TCP, 5190 TCP
Asheron's Call	9000-9013 UDP, 28800-29000 TCP
Battlecom	2300-2400 TCP/UDP, 47624 TCP/UDP
Black and White	2611-2612 TCP, 6667 TCP, 6500 UDP, 27900 UDP
Blizzard Battle.net (Diablo II)	4000 TCP, 6112 TCP/UDP
Buddy Phone	700, 701 UDP
Bungie.net, Myth, Myth II Server	3453 TCP
Calista IP Phone	3000 UDP, 5190 TCP
Citrix Metaframe	1494 TCP
Client POP/IMAP	110 TCP
Client SMTP	25 TCP
Counter Strike	27015 TCP/UDP, 27016 TCP/UDP
Dark Reign 2	26214 TCP/UDP
Delta Force (Client and Server)	3568 UDP, 3100-3999 TCP/UDP
Delta Force 2	3568-3569 UDP
DeltaForce: Land Warrior	UDP 53 TCP 21 TCP 7430 TCP 80 UDP 1029 UDP 1144 UDP 65436 UDP 17478
DNS	53 UDP
Elite Force	2600 UDP, 27500 UDP, 27910 UDP, 27960 UDP
Everquest	1024-7000 TCP/UDP
F-16, Mig 29	3863 UDP
F-22 Lightning 3	4660-4670 TCP/UDP, 3875 UDP, 4533-4534 UDP, 4660-4670 UDP
F-22 Raptor	3874-3875 UDP
Fighter Ace II	50000-50100 TCP/UDP
Fighter Ace II for DX play	50000-50100 TCP/UDP, 47624 TCP, 2300-2400 TCP/UDP

Application/Game	Port/Protocol
FTP	20 TCP, 21 TCP
GameSpy Online	UDP 3783 UDP 6515 TCP 6667 UDP 12203 TCP/UDP 13139 UDP 27900 UDP 28900 UDP 29900 UDP 29901
Ghost Recon	TCP 80 UDP 1038 UDP 1032 UDP 53 UDP 2347 UDP 2346
GNUtella	6346 TCP/UDP, 1214 TCP
Half Life Server	27005 UDP(client only) 27015 UDP
Heretic II Server	28910 TCP
Hexen II	26900 (+1) each player needs their own port. Increment by one for each person
Hotline Server	5500, 5503 TCP 5499 UDP
HTTPS	443 TCP/UDP
ICMP Echo	4 ICMP
ICQ OLD	4000 UDP, 20000-20019 TCP
ICQ 2001b	4099 TCP, 5190 TCP
ICUII Client	2000-2038 TCP, 2050-2051 TCP, 2069 TCP, 2085 TCP, 3010-3030 TCP
ICUII Client Version 4.xx	1024-5000 TCP, 2050-2051 TCP, 2069 TCP, 2085 TCP, 3010-3030 TCP, 2000-2038 TCP, 6700-6702 TCP, 6880 TCP, 1200-16090 TCP
IMAP	119 TCP/UDP
IMAP v.3	220 TCP/UDP
Internet Phone	22555 UDP
IPSEC ESP	PROTOCOL 50
IPSEC IKE	500 UDP
Ivisit	9943 UDP, 56768 UDP
KALI, Doom & Doom II	2213 UDP, 6666 UDP (EACH PC USING KALI MUST USE A DIFFERENT PORT NUMBER STARTING WITH 2213 + 1)
KaZaA	1214 TCP/UDP
Limewire	6346 TCP/UDP, 1214 TCP
Medal Of Honor: Allied Assault	TCP 80 UDP 53 UDP 2093 UDP 12201 TCP 12300 UDP 2135 UDP 2139 TCP/UDP 28900
mIRC Chat	6660-6669 TCP

Application/Game	Port/Protocol
Motorhead Server	16000 TCP/UDP, 16010-16030 TCP/UDP
MSN Game Zone	6667 TCP, 28800-29000 TCP
MSN Game Zone (DX 7 & 8 play)	6667 TCP, 6073 TCP, 28800-29000 TCP, 47624 TCP, 2300-2400 TCP/UDP
MSN Messenger	6891-6900 TCP, 1863 TCP/UDP, 5190 UDP, 6901 TCP/UDP
Napster	6699 TCP
Need for Speed 3, Hot Pursuit	1030 TCP
Need for Speed, Porsche	9442 UDP
Net2Phone	6801 UDP
NNTP	119 TCP/UDP
Operation FlashPoint	47624 UDP, 6073 UDP, 2300-2400 TCP/UDP, 2234 TCP
Outlaws	5310 TCP/UDP
Pal Talk	2090-2091 TCP/UDP, 2095 TCP, 5001 TCP, 8200-8700 TCP/UDP, 1025-2500 UDP
pcAnywhere host	5631 TCP, 5632 UDP, 22 UDP
Phone Free	1034-1035 TCP/UDP, 9900-9901 UDP, 2644 TCP, 8000 TCP
Quake 2	27910 UDP
Quake 3	27660 UDP Each computer playing QuakeIII must use a different port number, starting at 27660 and incrementing by 1. You'll also need to do the following: <ol style="list-style-type: none"> 1. Right click on the QIII icon 2. Choose "Properties" 3. In the Target field you'll see a line like "C:\Program Files\Quake III Arena\quake3.exe" 4. Add the Quake III net_port command to specify a unique communication port for each system. The complete field should look like this: "C:\Program Files\Quake III Arena\quake3.exe" +set net_port 27660 5. Click OK. 6. Repeat for each system behind the NAT, adding one to the net_port selected (27660,27661,27662)
Quicktime 4/Real Audio	6970-32000 UDP, 554 TCP/UDP
Rainbow Six & Rogue Spear	2346 TCP
RealOne Player	TCP - 554, 7070 to 7071 UDP - 6970 to 7170
Real Audio	6970-7170 UDP
Roger Wilco	TCP/UDP 3782 UDP 3783 (BaseStation)
ShoutCast Server	8000-8005 TCP
SSH Secure Shell	22 TCP/UDP
Starcraft	2346 TCP
Starfleet Command	2300-2400 TCP/UDP, 47624 TCP/UDP
Telnet	23 TCP
Tiberian Sun & Dune 2000	1140-1234, 4000 TCP/UDP
Ultima Online	5001-5010 TCP, 7775-7777 TCP, 8800-8900 TCP, 9999 UDP, 7875 UDP
Unreal Tournament server	7777 (default gameplay port) 7778 (server query port) 7779,7779+ are allocated dynamically for each helper UdpLink objects,

Application/Game	Port/Protocol
	including UdpServerUplink objects. Try starting with 7779-7781 and add ports if needed 27900 server query, if master server uplink is enabled. Home master servers use other ports like 27500 Port 8080 is for UT Server Admin. In the [UWeb.WebServer] section of the server.ini file, set the ListenPort to 8080 and ServerName to the IP assigned to VersaLink from your ISP.
USENET News Service	143 TCP
VNC, Virtual Network Computing	5500 TCP, 5800 TCP, 5900 TCP
Westwood Online, C&C	4000 TCP/UDP, 1140-1234 TCP/UDP
World Wide Web (HTTP)	80 TCP 443 TCP (SSL) 8008 OR 8080 TCP (PROXY)
XBOX Live	TCP/UDP 88 and 3074
Yahoo Messenger Chat	5000-5001 TCP
Yahoo Messenger Phone	5055 UDP
VPN Protocol	Comments
IPSec Encryption	IPSec using AH can not be supported through NAT. IPSec using ESP and L2TP can be supported via an ALG
L2TP	IPSec using ESP and L2TP can be supported via an ALG.
PPTP	Works through NAT.



17. TECHNICAL SUPPORT INFORMATION

Westell Technical Support

If technical assistance is required, contact Westell by using one of the following options:

North America

Phone: 1-630-375-4900

U.K./Europe

Phone: (44) 01256 843311

Visit Westell at www.Westell.com to view frequently asked questions and enter on-line service requests, or send email to global_support@westell.com to obtain additional information.

18. WARRANTY AND REPAIRS

Warranty

Westell warrants this product free from defects at the time of shipment. Westell also warrants this product fully functional for the period specified by the terms of the warranty. Any attempt to repair or modify the equipment by anyone other than an authorized representative will void the warranty.

Repairs

Westell will repair any defective Westell equipment without cost during the warranty period if the unit is defective for any reason other than abuse, improper use, or improper installation, or acts of nature. Before returning the defective equipment, request a **Return Material Authorization (RMA)** number from Westell. An RMA number must be quoted on all returns. When requesting an RMA, please provide the following information:

- Product model number (on product base)
- Product serial number (on product base)
- Customer ship-to address
- Contact name
- Problem description
- Purchase date

After an RMA number is obtained, return the defective unit, freight prepaid, along with a brief description of the problem to one of the following options:

North America

Westell, Inc.
ATTN: R.G.M Department
750 N. Commons Drive
Aurora, IL 60504-7940 USA

U.K./Europe

Westell, Ltd.
Ringway House
Bell Road
Daneshill
Basingstoke
RG24 8FB
United Kingdom

Westell will continue to repair faulty equipment beyond the warranty period for a nominal charge. Contact a Westell Technical Support Representative for details.

19. PRODUCT SPECIFICATIONS

ADSL

- DSL Line Code: Discrete Multi-Tone (DMT)
- DSL Rates: 32 kbps to 8 Mbps downstream and 32 kbps to 800 kbps upstream
- Power spectral density: less than -34 dBm/Hz
- DSL Impedance: 100 Ohms
- DSL Performance: per ITU Recommendation G.991.2, ANSI T1.413
- Upgradeable to ADSL2, ADSL2+, READSL

Protocol Features

- Bridge Encapsulation per RFC2684 (Formerly RFC1483)
- Logical Link Control/Subnetwork
- Access Protocol (LLC/SNAP)
- Software Upgradeable
- PPPoE Support
- ATM SAR: Internal to Modem

System Requirements for 10/100 Base-T/Ethernet

- Pentium® or equivalent and above machines
- Microsoft Windows (95, 98, ME, 2000, NT 4.0, or XP) Macintosh OS X, or Linux installed
- Operating system CD
- Internet Explorer 4.x or Netscape Navigator 4.x or higher
- 64 MB RAM (128 MB recommended)
- Ethernet 10/100 Base-T interface
- 10 MB of free hard drive space
- TCP/IP Protocol stack installed

System Requirements for Wireless

- Pentium® or equivalent and above class machines
- Microsoft® Windows® (98 ME, 2000, or XP) or Macintosh® OS X installed
- Operating System CD on hand

- Internet Explorer 4.x or Netscape Navigator 4.x or higher
- 64 MB RAM (128 MB recommended)
- 10 MB of free hard drive space
- IEEE 802.11b/g+ PC adapter

LEDs

- Power
- Ethernet
- Wireless
- DSL
- Internet

Connectors

- DSL: RJ-11, 6-pin modular jack-DSL
- Ethernet: RJ-45: 8-pin modular jack
- Power: Connector
- SMA antenna

Power

- Power Supply: External 120 VAC to 12V DC wall-mount power supply
- Power Consumption: Less than 6 watts typical, from 120 VAC

Environmental

- Ambient Operating Temperature: +32 to +104°F (0 to +40°C)
- Relative Humidity: 5 to 95%, non-condensing

EMC/Safety/Regulatory Certifications

- EMC: FCC Part 15, Class B
- UL Standard 60950, 3rd Edition
- CAN/CSA Standard C22.2 No. 60950
- UL
- CSA
- ACTA 968-A
- Industry Canada CS03

20. SOFTWARE LICENSE AGREEMENT

READ THE TERMS AND CONDITIONS OF THIS LICENSE AGREEMENT CAREFULLY. THIS SOFTWARE IS COPYRIGHTED AND LICENSED (NOT SOLD). BY INSTALLING AND OPERATING THIS PRODUCT, YOU ARE ACCEPTING AND AGREEING TO THE TERMS OF THIS LICENSE AGREEMENT. IF YOU ARE NOT WILLING TO BE BOUND BY THE TERMS OF THIS LICENSE AGREEMENT, YOU SHOULD PROMPTLY RETURN THE SOFTWARE AND HARDWARE TO WESTELL TECHNOLOGIES, INC. THIS LICENSE AGREEMENT REPRESENTS THE ENTIRE AGREEMENT CONCERNING THE SOFTWARE BETWEEN YOU AND WESTELL TECHNOLOGIES, INC. (REFERRED TO AS "LICENSOR"), AND IT SUPERSEDES ANY PRIOR PROPOSAL, REPRESENTATION, OR UNDERSTANDING BETWEEN THE PARTIES.

1. License Grant. Licensor hereby grants to you, and you accept, a nonexclusive license to use the Compact Disk (CD) and the computer programs contained therein in machine-readable, object code form only (collectively referred to as the "SOFTWARE"), and the accompanying User Documentation, only as authorized in this License Agreement. The SOFTWARE may be used only in connection with the number of systems for which you have paid license fees as dictated in your support agreement. You agree that you will not assign, sublicense, transfer, pledge, lease, rent, or share your rights under this License Agreement. You agree that you may not nor allow others to reverse assemble, reverse compile, or otherwise translate the SOFTWARE.

You may retain the SOFTWARE CD for backup purposes only. In addition, you may make one copy of the SOFTWARE in any storage medium for backup purposes only. You may make one copy of the User's Manual for backup purposes only. Any such copies of the SOFTWARE or the User's Manual shall include Licensor's copyright and other proprietary notices. Except as authorized under this paragraph, no copies of the SOFTWARE or any portions thereof may be made by you or any person under your authority or control.

2. Licensor's Rights. You acknowledge and agree that the SOFTWARE and the User's Manual are proprietary products of Licensor protected under U.S. copyright law. You further acknowledge and agree that all right, title, and interest in and to the SOFTWARE, including associated intellectual property rights, are and shall remain with Licensor. This License Agreement does not convey to you an interest in or to the SOFTWARE, but only a limited right of use revocable in accordance with the terms of this License Agreement.

3. License Fees. The fees paid by you under the support agreement are paid in consideration of the licenses granted under this License Agreement.

4. Term. This License Agreement is effective upon your opening of this package and shall continue until terminated. You may terminate this License Agreement at any time by returning the SOFTWARE and all copies thereof and extracts there from to Licensor. Licensor may terminate this License Agreement upon the breach by you of any term hereof. Upon such termination by Licensor, you agree to return to Licensor the SOFTWARE and all copies and portions thereof.

5. Limited Warranty. Licensor warrants, for your benefit alone, for a period of 90 days from the date of commencement of this License Agreement (referred to as the "Warranty Period") that the SOFTWARE CD in which the SOFTWARE is contained are free from defects in material and workmanship. Licensor further warrants, for your benefit alone, that during the Warranty Period the SOFTWARE shall operate substantially in accordance with the functional specifications in the User's Manual. If during the Warranty Period, a defect in the SOFTWARE appears, you may return the SOFTWARE to Licensor for replacement. You agree that the foregoing constitutes your sole and exclusive remedy for breach by Licensor of any warranties made under this Agreement.



EXCEPT FOR THE WARRANTIES SET FORTH ABOVE, THE SOFTWARE CD, AND THE SOFTWARE CONTAINED THEREIN, ARE LICENSED "AS IS," AND LICENSOR DISCLAIMS ANY AND ALL OTHER WARRANTIES, WHETHER EXPRESS OR IMPLIED, INCLUDING, WITHOUT LIMITATION, ANY IMPLIED WARRANTIES OF MERCHANTABILITY OR FITNESS FOR A PARTICULAR PURPOSE.

6. **Limitation of Liability.** Licensor's cumulative liability to you or any other party for any loss or damages resulting from any claims, demands, or actions arising out of or relating to this Agreement shall not exceed the license fee paid to Licensor for the use of the SOFTWARE. In no event shall Licensor be liable for any indirect, incidental, consequential, special, or exemplary damages or lost profits, even if Licensor has been advised of the possibility of such damages. **SOME STATES DO NOT ALLOW THE LIMITATION OR EXCLUSION OF LIABILITY FOR INCIDENTAL OR CONSEQUENTIAL DAMAGES, SO THE ABOVE LIMITATION OR EXCLUSION MAY NOT APPLY TO YOU.**

7. **Governing Law.** This License Agreement shall be construed and governed in accordance with the laws of the State of Illinois. You submit to the jurisdiction of the state and federal courts of the state of Illinois and agree that venue is proper in those courts with regard to any litigation arising under this Agreement.

8. **Costs of Litigation.** If any action is brought by either party to this License Agreement against the other party regarding the subject matter hereof, the prevailing party shall be entitled to recover, in addition to any other relief granted, reasonable attorney fees and expenses of litigation.

9. **Severability.** Should any term of this License Agreement be declared void or unenforceable by any court of competent jurisdiction, such declaration shall have no effect on the remaining terms hereof.

10. **No Waiver.** The failure of either party to enforce any rights granted hereunder or to take action against the other party in the event of any breach hereunder shall not be deemed a waiver by that party as to subsequent enforcement of rights or subsequent actions in the event of future breaches.

21. PUBLICATION INFORMATION

Westell® VersaLink™ Gateway (Model 327W)
User Guide Part Number 030-300500 Rev. A

Copyright © 2006 Westell, Inc.
All rights reserved.

Westell, Inc.
750 North Commons Drive
Aurora, Illinois 60504 USA
www.westell.com

All trademarks and registered trademarks are the property of their respective owners.



Free Manuals Download Website

<http://myh66.com>

<http://usermanuals.us>

<http://www.somanuals.com>

<http://www.4manuals.cc>

<http://www.manual-lib.com>

<http://www.404manual.com>

<http://www.luxmanual.com>

<http://aubethermostatmanual.com>

Golf course search by state

<http://golfingnear.com>

Email search by domain

<http://emailbydomain.com>

Auto manuals search

<http://auto.somanuals.com>

TV manuals search

<http://tv.somanuals.com>