

LX & LX-E Series Technical Specifications

MODEL	LX-12 / LX-12E	LX-12M / LX-12ME	LX15 / LX15E	LX15M / LX15ME	LX-215 / LX215E	LX-15B / LX15BE	LX-18B / LX-18BE	LX-18MB / LX18MBE	LX218B / LX218BE
APPLICATIONS	2-way	2-way monitor	2-way	2-way monitor	Quasi 3-way	subwoofer	subwoofer	subwoofer	subwoofer
FREQUENCY RESPONSE @ +/- 3 dB	50-20kHz	60-20kHz	40-20kHz	55-20kHz	40-20kHz	42-170Hz (LX-15B) 42-2kHz (LX-15BE)	38-150Hz (LX-18B) 38-1.5kHz (LX-18BE)	38-1.5kHz	30-1.5kHz
SENSITIVITY 1w@1m (dB)	97	97	98	98	101	98	99	99	100
COVERAGE Horiz.	90	90	90	90					
COVERAGE vert.	45°	45°	45°	45°					
POWER HANDLING (watts)									
continuous	400	350	400	350	700	700	800	800	1600
music	800	700	800	700	1400	1400	1600	1600	3200
peak	1600	1400	1600	1400	2800	2800	3200	3200	6400
MAX SPL (dB)	129	128	130	129	135	132	134	134	138
SYSTEM IMPEDANCE	4 or 8	8	4 or 8	8	4	4 or 8	4 or 8	4 or 8	4
LF DRIVER									
driver size	12"	12"	15"	15"	15"	15"	18"	18"	18"
HF SECTION									
impedance (W)	8	8	8	8	8				
coil size (mm/ins)	50 / 2"	50 / 2"	50 / 2"	50 / 2"	50 / 2"				
exit size (mm/ins)	35 / 1.4"	35 / 1.4"	35 / 1.4"	35 / 1.4"	35 / 1.4"				
diaphragm matl	Titanium	Titanium	Titanium	Titanium	Titanium				
protect type	bulb	bulb	bulb	bulb	bulb				
HF HORN									
type	Elliptical	Elliptical	Elliptical	Elliptical	Elliptical				
CROSSOVER SECTION									
crossover Frequency	1.8k	1.8k	1.8k	1.8k	1.8k	170Hz (LX-15B only)	150Hz (LX-18B only)		
system Fb	50Hz	60Hz	40Hz	55Hz	40Hz	42Hz	38Hz	38Hz	30Hz
hi pass out						120Hz (LX-15B only)	120Hz (LX-18B only)		
ENCLOSURE TYPE									
finish colour (LX)	carpet black	carpet black	carpet black	carpet black	carpet black	carpet black	carpet black	carpet black	carpet black
finish colour (LX-E)	paint black	paint black	paint black	paint black	paint black	paint black	paint black	paint black	paint black
construction materials (LX)	MDF/particle	MDF/particle	MDF/particle	MDF/particle	MDF/particle	MDF/particle	MDF/particle	MDF/particle	MDF/particle
construction materials (LX-E)	15mm plywood	15mm plywood	15mm plywood	15mm plywood	18mm plywood	18mm plywood	18mm plywood	18mm plywood	18mm plywood
RIGGING HARDWARE	12 x M10 flying inserts (LX-12E only)	no	12 x M10 flying inserts (LX-15E only)	no	no	no	no	no	no
STAND ADAPTOR	yes	no	yes	no	no	yes	yes	yes	yes
HANDLE									
type	square	square	square	square	square	square	square	square	square
quantity	2	2	2	2	3	2	4	2	4
GRILLE									
thickness (mm)	1.5	1.5	1.5	1.5	1.5	1.5	1.5	1.5	1.5
type	full steel	full steel	full steel	full steel	full steel	full steel	full steel	full steel	full steel
INPUT CONNECTOR									
speakon™ NL4 type	2	2	2	2	2	2	2	2	2
paralle with input connector	yes	yes	yes	yes	yes	yes	yes	yes	yes
hi pass out connector:	no	no	no	no	no	LX-15B only	LX-18B only	no	no
CASTOR	no	no	no	no	2	no	no	no	4 (LX-218E only)
PRODUCT DIMS. (mm)									
H	630	618	700	685.5	1138	615	715	545	541
W (front / rear)	396 / 269	426 / 426	470 / 319	500 / 500	506 / 356	470 / 275	570 / 336	545 / 545	1041 / 1041
D	396	450	450	493	461	559	652	650	650
WEIGHT (KG)									
net (LX / LX-E)	26.5 / 27.8	21.5 / 22.5	33.5 / 34.6	28.4 / 29.5	59.0 / 60.6	33.5 / 35.6	45.5 / 47.9	39.0 / 40.4	67.5 / 70.8
gross (LX / LX-E)	28.1 / 30.4	23.1 / 25.1	35.7 / 38.3	30.6 / 32.9	63.2 / 66.8	36.3 / 40.1	48.7 / 52.9	42.2 / 44.6	74.4 / 78.9

WPSX012005

LX & LX-E SERIES

Professional Loudspeaker System

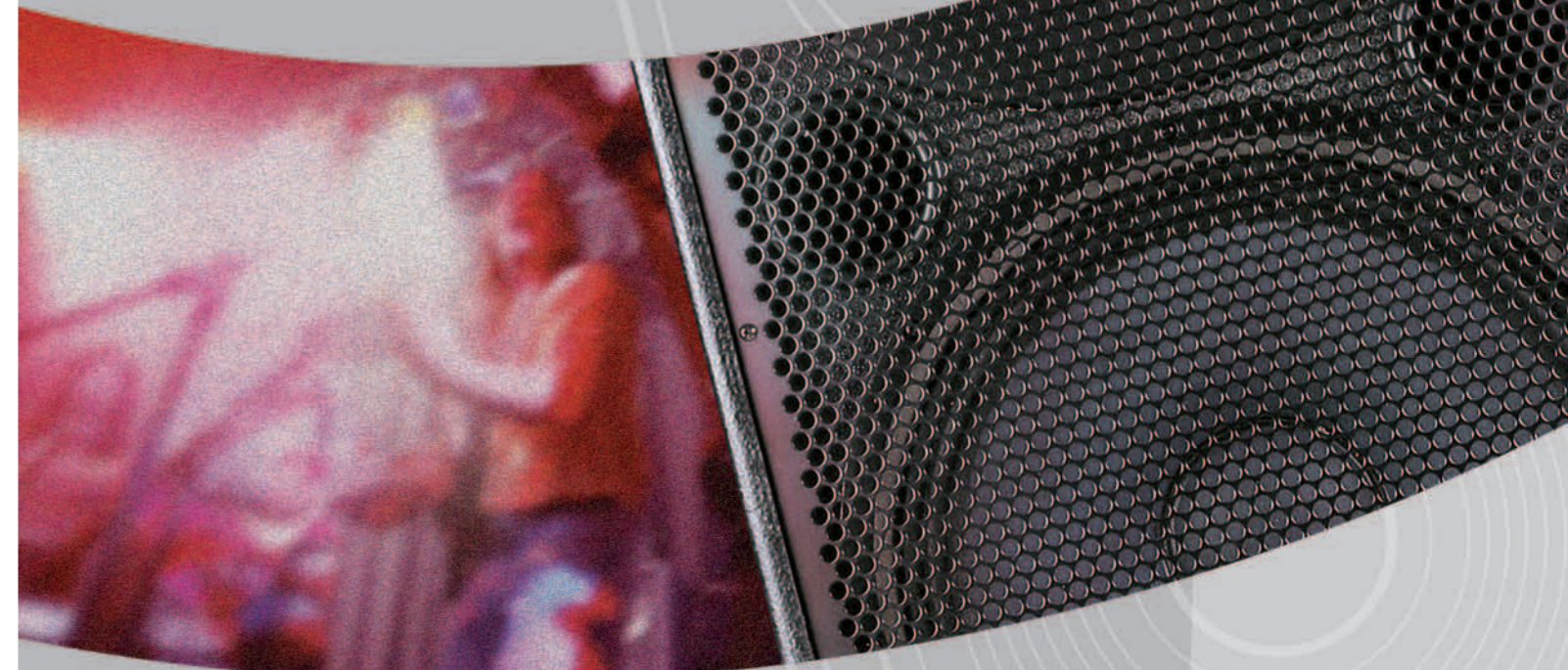

IAG
International Audio Group

Wharfedale International Limited
IAG House, Sovereign Court, Ermine Business Park,
Hungtingdon Cambs, PE29 6XU, England
IAG America Inc.
15 Walpole Park South, Walpole MA02081, USA

www.wharfedalepro.com

The information in this manual is subject to change without notice.
All rights to the mentioned trademarks reside with their respective companies.
All rights reserved © 2004 Wharfedale Pro
Wharfedale Pro is a member of International Audio Group

Wharfedale
Pro

Value, Integrity and Performance

Created from the ground up into the demanding, high performance world of professional audio, Wharfedale Professional enjoys global success with a range of great value, great sounding, and innovative products. The Wharfedale Professional philosophy is simple: Value, Integrity and Performance – VIP.

Since 1932, Wharfedale has been at the forefront of loudspeaker technology – these seventy years of experience in the design and manufacture of audio systems make Wharfedale Pro products second to none.

We put in a lifetime of experience – you get out a lifetime of performance.

EXTENSIVE LX & LX-E SERIES COVER THE HIGH-PERFORMANCE SPECTRUM

The new LX and LX-E Series of loudspeakers each consist of nine models in total, comprising five full ranges (with FOH and monitor systems in both 12 inch and 15 inch versions), and four sub bass cabinets (in both 15 inch and 18 inch versions).

Boasting distinctive style and features, these high powered, high performance arrayable trapezoidal enclosures are capable of extremely high sound pressure levels and exceptional sonic quality with wide dynamic range and bandwidth.

Both series have been developed with exceptional features including the large elliptical Wave Guide horn, the use of cast-iron, large voice coil woofers for sustained output capability and minimal power compression under extended high-power use, and the ProTech™ protection system designed to protect the HF unit, just to name a few.

In creating the LX Series, we set some basic parameters to design a range that delivers without exception the performance, features and quality that our customers demand. We also kept it simple; the LX-E range has a 'systems' approach, a range of models that can be used together to provide solutions for nearly every audio challenge.

NEW LOOK, DISTINCTIVE FEATURES, HIGH STANDARD, GREAT POWER AND MORE CHOICES.

Elliptical Wave Guide Horn (1.4" Exit)

In comparison to a conventional rectangular horn, the elliptical Wave Guide offers superior control over HF coverage, with reduced distortion, greater output and smoother frequency response. The elliptical shape means that there are no corners or parallel surfaces to distort, diffract or reflect the sound – therefore the output is smoother, cleaner and more consistent. Again, due to the elliptical shape, mid to high frequencies are diffused more efficiently.



Large elliptical wave guide horn provides superior control over HF coverage

Titanium 50mm Diaphragm, 1.4" Exit Compression Driver

The elliptical Wave Guide horn is coupled with a 50mm (2") true compression driver designed specially for the LX and LX-E Series. This titanium diaphragm driver features a 1200g-magnet with a 35mm (1.4") exit for brilliant, natural HF reproduction.



Large magnet structure and tight construction tolerances give accuracy, high efficiency and reliability

ProTech™ Driver Overload Protection System

Understanding that sound systems are often asked to perform beyond their original design parameters, we have designed a smooth, progressive dynamic limiter/protection system that is carefully tailored to each model. Overloads are limited and drivers are protected against long term transient or peak conditions. The ProTech™ system progressively converts excess power to heat and triggers a reduction in power to the HF driver. When the overload condition is removed the system returns seamlessly to normal operation.

Sophisticated Crossovers Design

Each crossover in the LX and LX-E Series is built using the highest quality components and designed specifically for that system, enabling smooth power and frequency response control through the crossover region. The LX-15B and LX-18B feature integral two-way networks that allow a four-box system to be powered by one amplifier.

Trapezoidal, Plywood and Composite Construction

The LX-E's cabinet is constructed from plywood on all critical surfaces (where durability is important) and wood composite where resonances need to be kept to a minimum. The trapezoidal shape further improves sonic accuracy by significantly reducing internal flutter echoes and standing wave resonances that are often apparent in rectangular shape cabinets.

Mounting points:

For maximum flexibility when installing, we have designed two specific models which feature 12 x M10 rigging points allowing the cabinets to be flown or arrayed. The LX-12E and LX-15E are fitted with these flying inserts.

Protective Finish

The LX is all finished using a tough, black industrial carpet offering exceptional protection and durability for life on the road. The LX-E is coated with Duraguard™, an abrasion resistant paint that creates a protective 'skin' around the cabinet. Both finishes contribute to the overall safety in the set up and use.

Strong Grille, Square Handles and Castors

In order to provide maximum protection to the internal components of the loudspeakers, the front grilles are full steel and 1.5mm thick. The square handles allow the cabinets to be gripped securely and comfortably, therefore making them easy to move. Built-in castors are available on some larger units for ease of transportation.

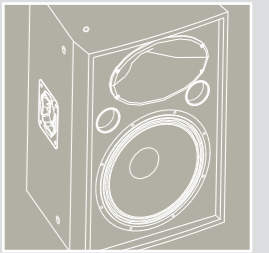

Trapezoidal designs allow more compact arrays and sonic accuracy

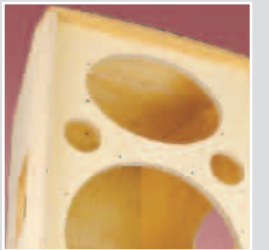

Enclosures of the LX-E constructed from premium grade plywood for durability

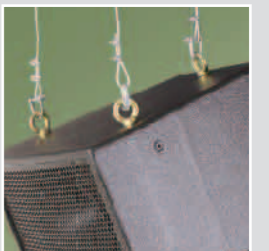

Secure rigging points (LX-12E & LX-15E only)



Durable black carpet covering (LX Series only) | Highly protective Duraguard™ coating (LX-E Series only)

Heavy duty protective steel grille | Built-in castors for larger enclosures



Secure square handles

With enclosures built from a combination of particle and MDF in a black carpet finish, the LX is ideal for use in live sound applications.

With enclosures built from plywood in a black paint finish, the LX-E has extra features to make it more suitable for the installation market.

LX and LX-E SERIES PROVIDE EXCELLENT SOUND PROJECTION, VOCAL PERFORMANCE AND BALANCED MUSICAL REPRODUCTION

In the LX Series, the powerful LX-15B, LX-18B, LX-18MB and LX-218B sub bass systems have been designed for use with large-scale LX-12, LX-15 and LX-215 systems to extend LF output power.

In demanding professional applications, the LX-15B and LX-18B, which feature an internal two-way network, allow a four box system to be powered by one amplifier. Tough industrial carpet covering provides durability and protection, and contributes to the overall safety in the set-up and use of the LX systems.

The LX-E Series has the same model line up as the LX Series. The LX-E is finished in a hardwearing, two-stage epoxy black paint finish and is constructed from premium grade plywood for extra strength. Among the whole series, the LX-12E and LX-15E have multiple mounting points for maximum flexibility when installing.

In comparison to the LX Series, the LX-E also has the same power ratings.

FEATURES

- High Performance, arrayable trapezoidal cabinets
- 50 mm Titanium diaphragm true compression driver for brilliant, natural HF reproduction
- Large Elliptical Wave Guide Horn provides superior control over HF coverage with reduced distortion, greater output and smoother frequency response
- Cast frame, large voice coil woofers for sustained output capability and minimal power compression under extended high power use.
- Heavily braced enclosure
- Dynamic, full range frequency response
- ProTech™ driver protection system
- Recessed metal jack plates with series Speakon™ type and 1/4" inputs
- Cast aluminum, 35mm pole adaptor for stand mounting



MULTIPURPOSE LOUDSPEAKER SYSTEM



LX-12, LX-12E

Two-way, 12" high power woofer; elliptical wave guide horn with 2" (50mm) titanium diaphragm driver; Trapezoidal enclosure, 12 X M10 rigging points for mounting (LX-12E only),

Continuous 400W/Music 800W power handling.

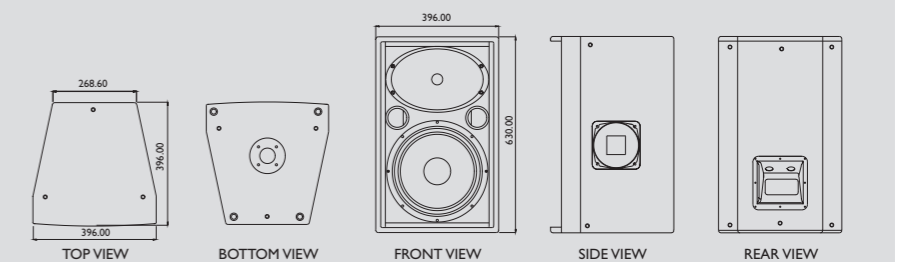

LX-12M, LX-12ME

Two-way monitor. 12" high power woofer; elliptical wave guide horn with 2" (50mm) titanium diaphragm driver;

Continuous 350W/Music 700W power handling.

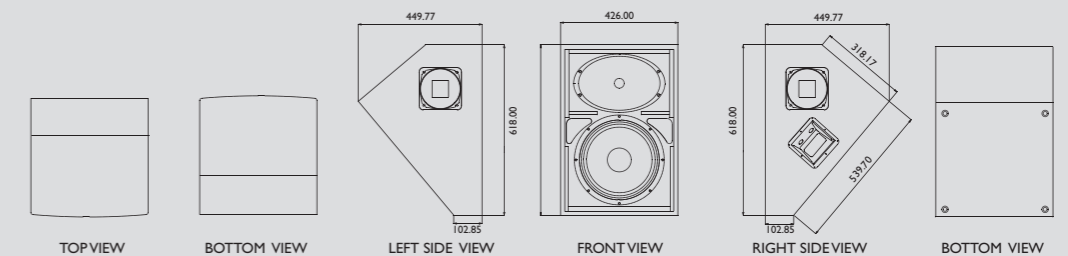

LX-15, LX-15E

Two-way, 15" high power woofer; elliptical wave guide horn with 2" (50mm) titanium diaphragm driver; Trapezoidal enclosure, 12 X M10 rigging points for mounting (LX-15E only),

Continuous 400W/Music 800W power handling.

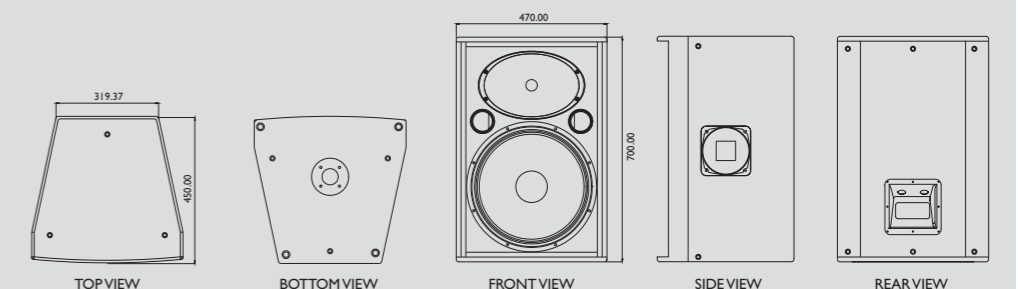

The LX and LX-E Series of loudspeakers each consist of nine models in total, comprising five full ranges multipurpose systems (with FOH and monitor systems in both 12 inch and 15 inch versions), and four sub bass cabinets (in both 15 inch and 18 inch versions).

MULTIPURPOSE LOUDSPEAKER SYSTEM



LX-15M, LX-15ME

Two-way monitor, 15" high power woofer, elliptical wave guide horn with 2" (50mm) titanium diaphragm driver;
Continuous 350W/Music 700W power handling.

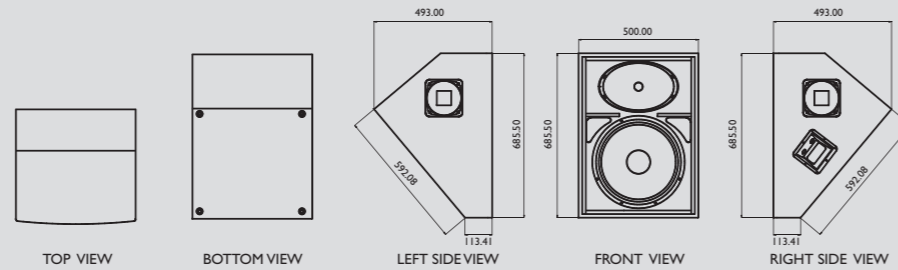

LX-18B, LX-18BE

Super subwoofer, 18" driver; Two Speakon™ type connector; Crossover with high pass output for mid/high (LX-18B only), Trapezoidal enclosure, Pole mount adaptor;
Continuous 800W/Music 1600W power handling.

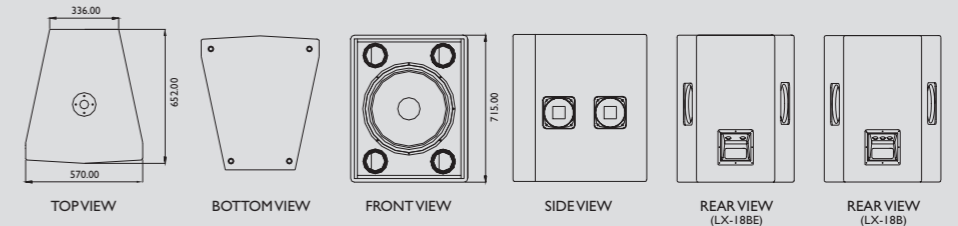

LX-215, LX-215E

Quasi 3-way, 15" high power woofer; elliptical wave guide horn with 2" (50mm) titanium diaphragm driver; Trapezoidal enclosure, Two castors built in,
Continuous 700W/Music 1400W power handling.

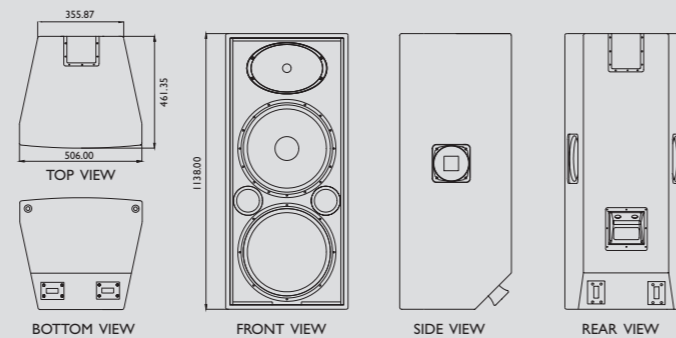

LX-18MB, LX-18MBE

18" (460mm) modular two way modular cluster element super subwoofer; Two Speakon™ type connector; Compact frontal dimensions, Co-axial ports, Pole mount adaptor; Use in blocks of four to provide astounding sub bass output levels
Continuous 800W/Music 1600W power handling

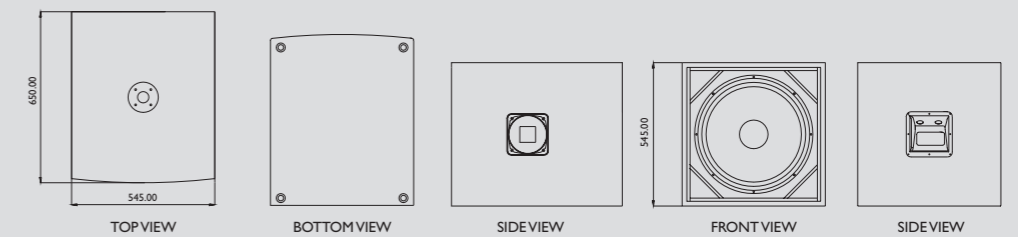

SUBWOOFER RANGE



LX-15B, LX-15BE

Super subwoofer, 15" driver; Two Speakon™ type connector; Crossover with high pass output for mid/high (LX-15B only), Trapezoidal enclosure, Pole mount adaptor;
Continuous 700W/Music 1400W power handling.

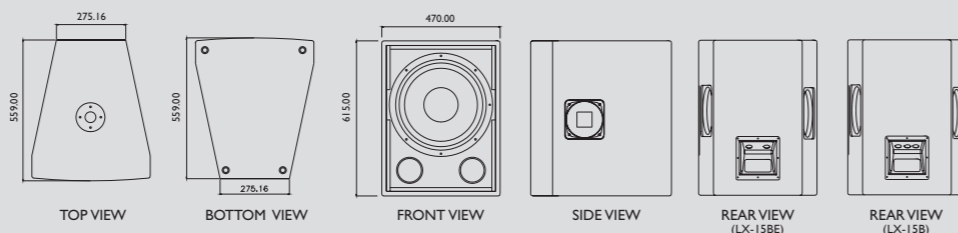

LX-218B, LX-218BE

Super subwoofer; 2 x 18" (460mm) drivers with 4" (100mm) high temperature voice coils for larger system set-ups; Two Speakon™ type connector; Rectangular enclosure, The birch ply cabinet is fitted with substantial handles and 4x4" (100mm) castors (LX-218BE only),
Continuous 1600W/Music 3200W power handling.

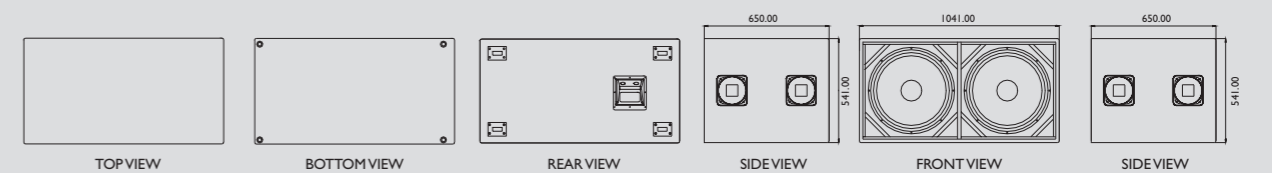

*No castors for LX-218B

Free Manuals Download Website

<http://myh66.com>

<http://usermanuals.us>

<http://www.somanuals.com>

<http://www.4manuals.cc>

<http://www.manual-lib.com>

<http://www.404manual.com>

<http://www.luxmanual.com>

<http://aubethermostatmanual.com>

Golf course search by state

<http://golfingnear.com>

Email search by domain

<http://emailbydomain.com>

Auto manuals search

<http://auto.somanuals.com>

TV manuals search

<http://tv.somanuals.com>