

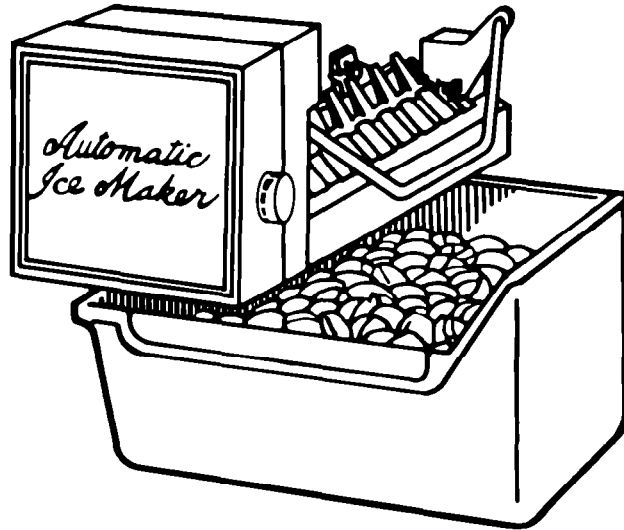

HOW TO INSTALL YOUR AUTOMATIC ICE MAKER



ECKMF-284

KEEP ALL PARTS IN THEIR OWN PACKAGE UNTIL NEEDED

PARTS ARE LISTED BY STEPS IN WHICH THEY ARE USED. ARRANGE IN ORDER BEFORE STARTING INSTALLATION. REFER TO **SERVICE PARTS LIST** FOR INDIVIDUAL REPLACEMENT PARTS.

PART NO.	NAME	NUMBER REQUIRED	USED IN STEP NUMBER
#1 939029	WIRING ASSEMBLY	1	3, 5
#2 836489	WATER TUBE FITTING	1	4
#3 -	NOT USED	-	-
#4 939027	WATER INLET TUBE (ALUMINUM)	1	5
#5 -	NOT USED	-	-
#6 538533	CLIPS	2	5
#7 489069	SCREWS	3	5, 6
#8 627820	WATER VALVE ASSEMBLY	1	14, 15
#9 939529	ICE BUCKET	1	6
#10 488878	CLAMP	1	7
#11 488645	SCREW	3	7, 10, 16
#12 841707	TUBE INSERT	1	7
#13 488366	CLAMPS	2	10
#14 939033	GROMMET	1	9
#15 488649	SCREW	2	15
#16 627709	PLASTIC TUBE ASSEMBLY	1	7, 17
#17 627858	COPPER TUBE ASSEMBLY	1	16
#18 939009	CLAMP	1	11
#19 1106508	SEAL GASKET	1	4

1

⚠ WARNING

Electrical Shock Hazard
Disconnect refrigerator from main power supply. Failure to do so could result in electrical shock.

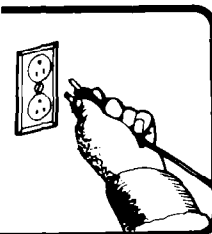

CONNECTING ICE MAKER TO FREEZER WALL

2 Remove Plugs and Cover From Freezer Wall

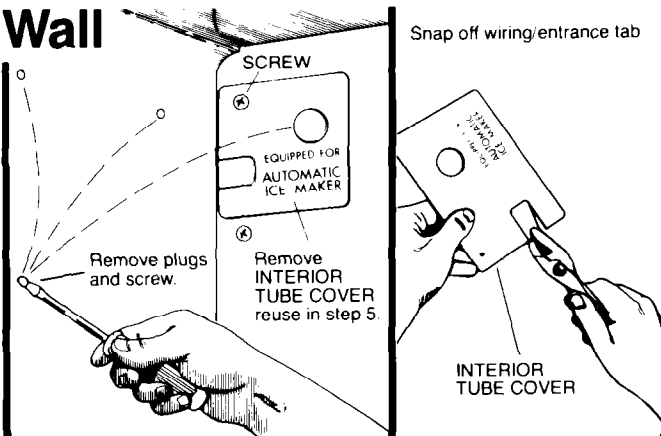

Remove plugs and screw.

Remove INTERIOR TUBE COVER reuse in step 5.

Snap off wiring/entrance tab

INTERIOR TUBE COVER

3 Remove Plugs From Refrigerator Back

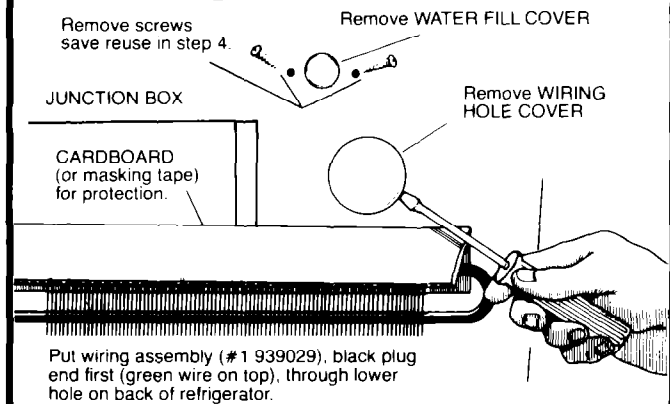

Remove screws save reuse in step 4.

Remove WATER FILL COVER

JUNCTION BOX

Remove WIRING HOLE COVER

CARDBOARD (or masking tape) for protection.

Put wiring assembly (#1 939029), black plug end first (green wire on top), through lower hole on back of refrigerator.

4 Install Water Tube

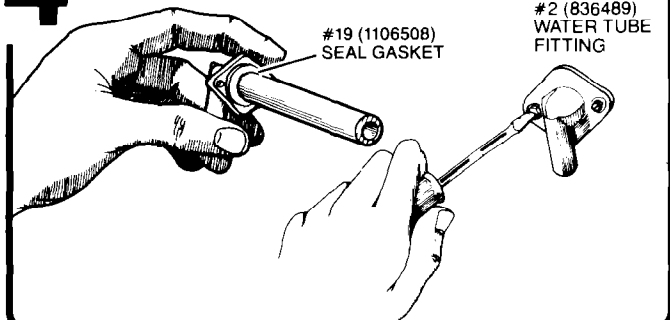

#19 (1106508) SEAL GASKET

#2 (836489) WATER TUBE FITTING

5 Install Clips And Shield

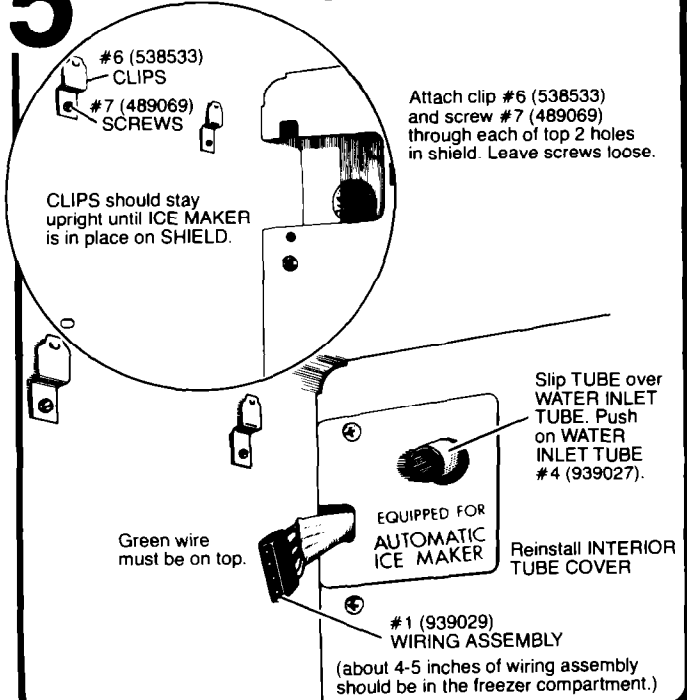

#6 (538533) CLIPS

#7 (489069) SCREWS

Attach clip #6 (538533) and screw #7 (489069) through each of top 2 holes in shield. Leave screws loose.

CLIPS should stay upright until ICE MAKER is in place on SHIELD.

Slip TUBE over WATER INLET TUBE. Push on WATER INLET TUBE #4 (939027).

Green wire must be on top.

EQUIPPED FOR AUTOMATIC ICE MAKER

Reinstall INTERIOR TUBE COVER

#1 (939029) WIRING ASSEMBLY (about 4-5 inches of wiring assembly should be in the freezer compartment.)

6 Plug-in Ice Maker

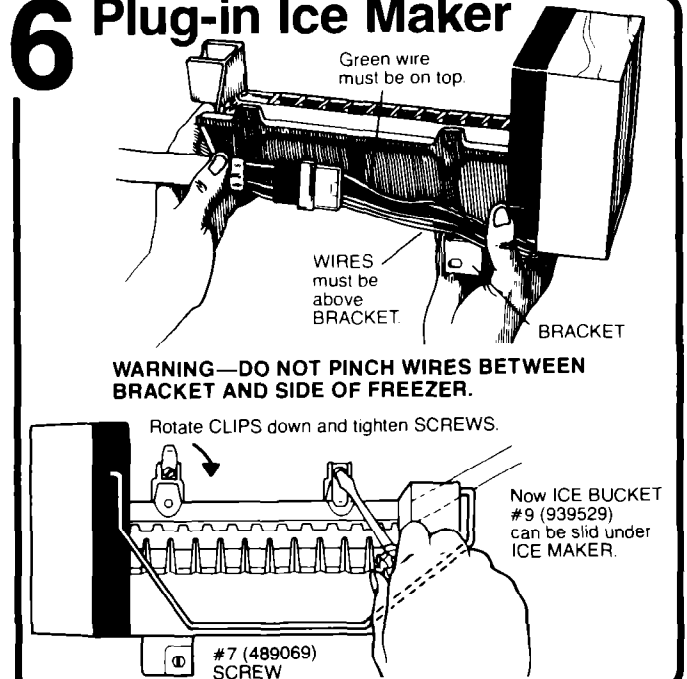

Green wire must be on top.

WIRES must be above BRACKET.

BRACKET

WARNING—DO NOT PINCH WIRES BETWEEN BRACKET AND SIDE OF FREEZER.

Rotate CLIPS down and tighten SCREWS.

Now ICE BUCKET #9 (939529) can be slid under ICE MAKER.

#7 (489069) SCREW

7 Connect Water Line Between Water Valve

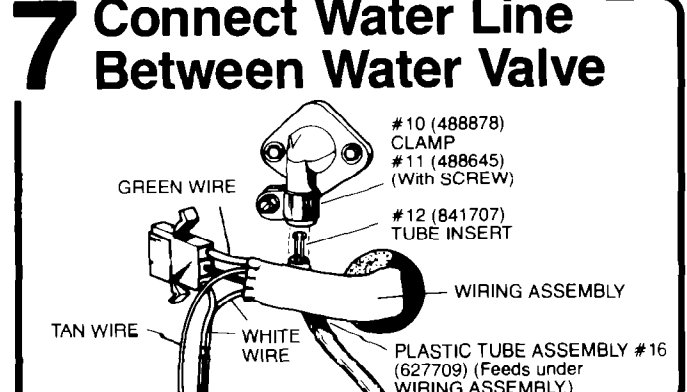

GREEN WIRE

TAN WIRE

WHITE WIRE

#10 (488878) CLAMP

#11 (488645) (With SCREW)

#12 (841707) TUBE INSERT

WIRING ASSEMBLY

PLASTIC TUBE ASSEMBLY #16 (627709) (Feeds under WIRING ASSEMBLY.)

8 Install Wiring Harness

Remove JUNCTION BOX.

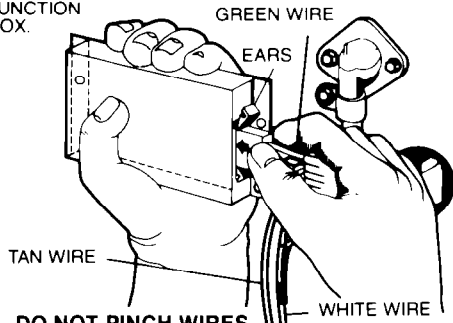

WARNING—DO NOT PINCH WIRES BETWEEN JUNCTION BOX AND CABINET

9 Insert Grommet Plate

Split GROMMET #14 (939033) around WIRING ASSEMBLY. Push into cabinet hole.

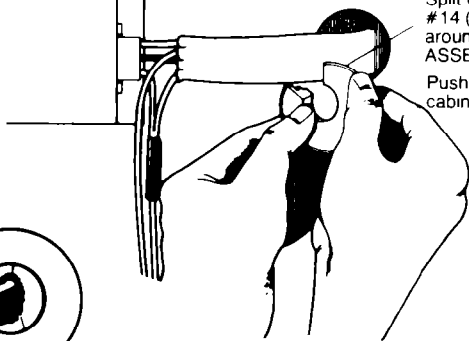

10 Wiring and Connections

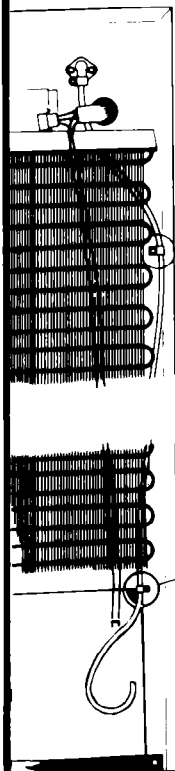

Remove SCREW. Slide CLAMP #13 (488366) over TUBING. Reinstall SCREW.

Slide CLAMP #13 (488366) over TUBING and install SCREW #11 (488645)

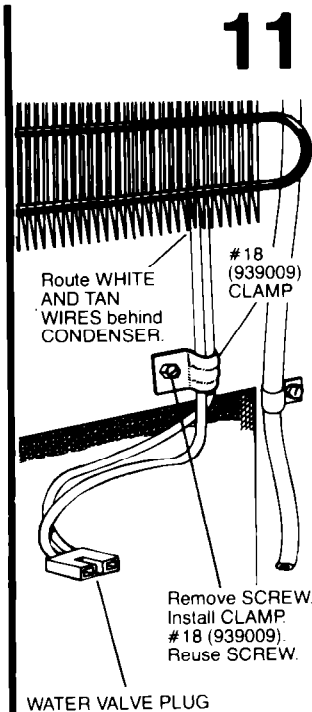

Route WHITE AND TAN WIRES behind CONDENSER.

11

#18 (939009) CLAMP

Remove SCREW. Install CLAMP #18 (939009). Reuse SCREW.

WATER VALVE PLUG

"OUTSIDE PARTS"-BAG

12 Now Go to Back Of Refrigerator to Hook-Up Water Line

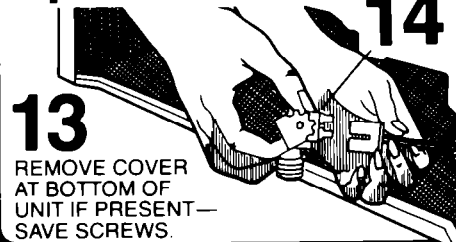

13 REMOVE COVER AT BOTTOM OF UNIT IF PRESENT—SAVE SCREWS.

14 HOOK-UP WATER VALVE #8 (Part No. 627820) TO TERMINALS SO TERMINALS ARE NOT EXPOSED.

15 WATER VALVE #8 (Part No. 627820)

ATTACH WATER VALVE TO RIGHT REAR LEG OF REFRIGERATOR WITH SCREW #15 (Part No. 488649). ATTACH WATER VALVE GROUND WIRE TO LEG OF REFRIGERATOR WITH SCREW #15 (Part No. 488649).

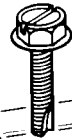

CHECK BEFORE INSTALLING TO SEE THAT BLACK RUBBER WASHER IS IN PLACE.

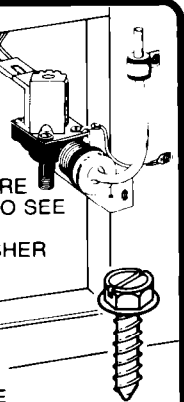

16 HOOK-UP COPPER TUBE ASSEMBLY #17 (Part No. 627858) TO WATER VALVE AND CLIP TO LEG WITH SCREW #11 (Part No. 488645).

Connect Water Line Between Water Valve (At The Bottom) To Inlet Tube (At The Top)

17

ATTACH WATER LINE #16 (Part No. 627709) BY PUSHING THE METAL INSERT END OF TUBING INTO WATER VALVE. TIGHTEN NYLON NUT (NOT TOO TIGHT) ONTO VALVE THREADS.

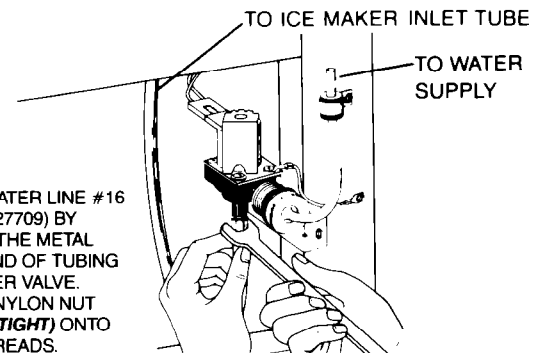

Connect Ice-Maker To Water (Contd.)

1. Find a 3/8-inch to 1-inch vertical COLD water pipe near the refrigerator. (Horizontal pipe will work...but extra precautions must be taken.) (See * in Step 4.)
2. Measure from inlet on rear of refrigerator to water pipe. Add 7 feet to allow for moving refrigerator for cleaning. This is the length of 1/4-inch O.D. copper tubing you will need for the job (length from inlet tube to water pipe PLUS 7 feet). Be sure both ends of copper tubing are cut square.
3. Turn OFF main water supply. Turn ON nearest faucet long enough to clear line of water.

⚠ WARNING

Electrical Shock Hazard

Electric drill must be grounded before drilling holes in water line. Failure to do so could result in electrical shock.

4. Some water almost always remains in pipes. If it enters the drill, it can cause lethal shock. YOUR DRILL MUST BE GROUNDED.

To ground electric drill:

Fasten a separate ground wire from drill to a good ground that complies with local electrical codes. (If in doubt, consult a licensed electrician.) UNLESS PROPER GROUNDING IS FOLLOWED, YOU ARE NOT PROTECTED AGAINST SEVERE OR LETHAL SHOCK.

Using a grounded drill, drill a 1/4-inch hole in the vertical cold water pipe you have selected.

*If you must use a horizontal pipe, take these extra precautions:

Drill on the top or side of the pipe, not the bottom. This helps keep water away from the drill. Also, it keeps normal sediment from collecting in the valve.

5. Fasten *shutoff valve* to cold water pipe with pipe clamp. Be sure *inlet end* is solidly in the 1/4-inch drilled hole in the water pipe and that *washer* is under the *pipe clamp*. Tighten packing nut. Tighten the *pipe clamp* screws carefully and evenly so *washer* makes a watertight connection. Do not overtighten or you may crush copper tubing, especially if soft copper tubing is used. Now you are ready to connect the copper tubing.

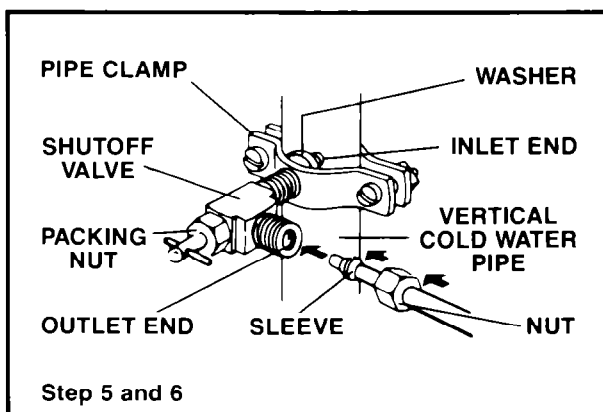

6. Slip *compression nut* and *compression sleeve* on copper tubing as shown in diagram. Insert end of tubing into *outlet end* squarely as far as it will go. Screw *compression nut* to *outlet end* with adjustable wrench. Do not overtighten. Turn ON main water supply and flush out tubing until water is clear. Turn OFF *shutoff valve* on the water pipe. You are now ready to connect other end of 1/4-inch copper tubing to inlet tube or water valve on back of refrigerator.
7. Assemble *compression nuts* on tubing as shown in diagram. Insert ends of tubing into *connector* and tighten *compression nuts*. Be sure ends of tubing are squarely in connector as far as they will go. Do not overtighten.

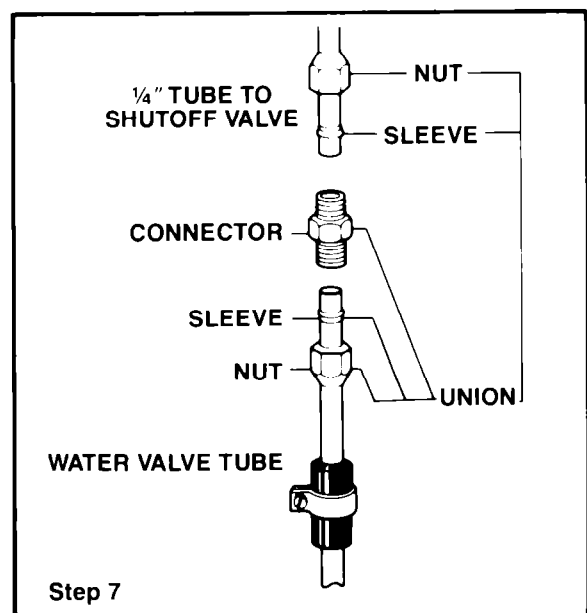

8. Turn shutoff valve ON. TIGHTEN ANY CONNECTIONS OR NUTS THAT LEAK.
9. Copper tubing may now be fastened to baseboard.
10. The Ice Maker has a built-in water strainer on the inlet side of the water valve. Use a second water strainer when local water conditions require periodic cleaning or a well is your source of water. The strainer can be installed in the 1/4-inch water line.
11. Water pressure should not be below (15 P.S.I.) or above (125 P.S.I.). If problem occurs call your Utility Company.
12. **PLUG IN YOUR REFRIGERATOR.**
When you have your first batch of ice you may throw away extra parts.

IMPORTANT:

It may take up to 24 hours for your Ice Maker to begin producing ice crescents.

To enjoy your Ice Maker most PLEASE READ CAREFULLY THE ICE MAKER SECTION OF YOUR USE AND CARE GUIDE.

Free Manuals Download Website

<http://myh66.com>

<http://usermanuals.us>

<http://www.somanuals.com>

<http://www.4manuals.cc>

<http://www.manual-lib.com>

<http://www.404manual.com>

<http://www.luxmanual.com>

<http://aubethermostatmanual.com>

Golf course search by state

<http://golfingnear.com>

Email search by domain

<http://emailbydomain.com>

Auto manuals search

<http://auto.somanuals.com>

TV manuals search

<http://tv.somanuals.com>