

AKZ 561

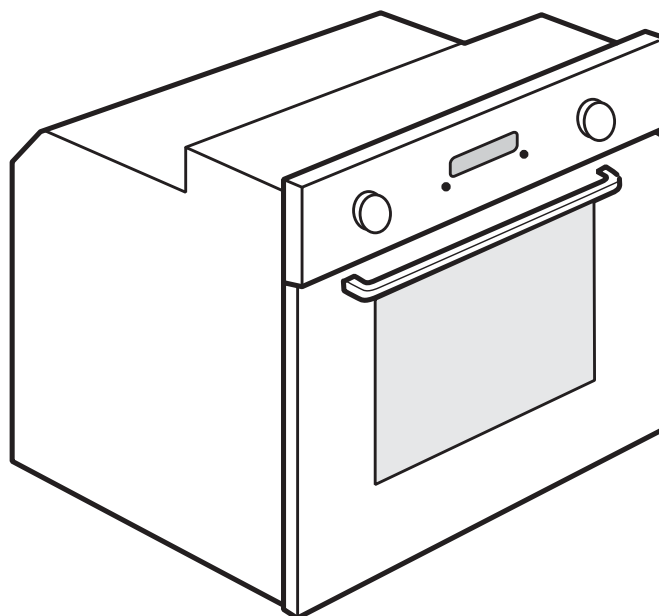

EN

User and maintenance manual

PL

Instrukcja obsługi i konserwacji

CS

Návod k použití a údržbě

SK

Návod na používanie a údržbu

HU

Felhasználói és karbantartási kézikönyv



IMPORTANT SAFETY INSTRUCTIONS

These instructions shall also be available on website: www.whirlpool.eu

YOUR SAFETY AND THAT OF OTHERS IS VERY IMPORTANT

This manual and the appliance itself provide important safety warnings, to be read and observed at all times.



This is the danger symbol, pertaining to safety, which alerts users to potential risks to themselves and others. All safety warnings are preceded by the danger symbol and the following terms:

! DANGER

Indicates a hazardous situation which, if not avoided, will cause serious injury.

! WARNING

Indicates a hazardous situation which, if not avoided, could cause serious injury.

All safety warnings give specific details of the potential risk present and indicate how to reduce risk of injury, damage and electric shock resulting from improper use of the appliance. Carefully observe the following instructions:

- Use protective gloves to perform all unpacking and installation operations.
- The appliance must be disconnected from the power supply before carrying out any installation work.
- Installation and maintenance must be carried out by a qualified technician, in compliance with the manufacturer's instructions and local safety regulations. Do not repair or replace any part of the appliance unless specifically stated in the user manual.
- Power cable replacement must be carried out by a qualified electrician. Contact an authorized service centre.
- Regulations require that the appliance is earthed.
- The power cable must be long enough for connecting the appliance, once fitted in its housing, to the main power supply.
- For installation to comply with current safety regulations, an all-pole disconnect switch with minimum contact gap of 3 mm must be utilized.
- Do not use multiple plug adaptors if the oven is fitted with a plug.
- Do not use extension leads.
- Do not pull the power supply cable.
- The electrical components must not be accessible to the user after installation.

- If the surface of the induction plate is cracked, do not use it and switch off the appliance to avoid the possibility of electric shock (only for models with induction function).
- Do not touch the appliance with any wet part of the body and do not operate it when barefoot.
- This appliance is designed solely for use as a domestic appliance for cooking food. No other type of use is permitted (e.g.: heating rooms). The Manufacturer declines all responsibility for inappropriate use or incorrect setting of the controls.
- The appliance and its accessible parts become hot during use. Care should be taken to avoid touching heating elements. Very young (0-3 years) and young children (3-8 years) shall be kept away unless continuously supervised.
- Children from 8 years and above and persons with reduced physical, sensory or mental capabilities or lack of experience and knowledge can use this appliance only if they are supervised or have been given instructions on safe appliance use and if they understand the hazards involved. Children shall not play with the appliance. Cleaning and user maintenance shall not be made by children without supervision.
- During and after use, do not touch the heating elements or interior surfaces of the appliance - risk of burns. Do not allow the appliance to come into contact with cloths or other flammable materials until all the components have cooled down completely.
- At the end of cooking, exercise caution when opening the appliance door, letting the hot air or steam exit gradually before accessing the oven. When the appliance door is shut, hot air is vented from the aperture above the control panel. Do not obstruct the vent apertures.
- Use oven gloves to remove pans and accessories, taking care not to touch the heating elements.
- Do not place flammable materials in or near the appliance: a fire may break out if the appliance is inadvertently switched on.
- Do not heat or cook sealed jars or containers in the appliance. The pressure that builds up inside might cause the jar to explode, damaging the appliance.

- Do not use containers made of synthetic materials.
- Overheated oils and fats catch fire easily. Always remain vigilant when cooking foods rich in fat and oil.
- Never leave the appliance unattended during food drying.
- If alcoholic beverages are used when cooking foods (e.g. rum, cognac, wine), remember that alcohol evaporates at high temperatures. As a result, there is a risk that vapours released by the alcohol may catch fire upon coming into contact with the electrical heating element.
- Never use steam cleaning equipment.
- Do not touch the oven during the pyrolysis cycle. Keep children away from the oven during the pyrolysis cycle. Excess spillage must be removed from the oven cavity before cleaning cycle (only for ovens with Pyrolysis function).
- Only use the temperature probe recommended for this oven.
- Do not use harsh abrasive cleaners or sharp metal scrapers to clean the oven door glass since they can scratch the surface, which may result in shattering of the glass.
- Ensure that the appliance is switched off before replacing the lamp to avoid the possibility of electric shock.
- Do not use aluminium foil to cover food in the cooking vessel (only for ovens with cooking vessel supplied).

Scrapping of household appliances

- This appliance is manufactured with recyclable or reusable materials. Dispose of it in accordance with local waste disposal regulations. Before scrapping, cut off the power supply cable.
- For further information on the treatment, recovery and recycling of household electrical appliances, contact your competent local authority, the collection service for household waste or the store where you purchased the appliance.

INSTALLATION

After unpacking the oven, make sure that it has not been damaged during transport and that the oven door closes properly. In the event of problems, contact the dealer or your nearest After-sales Service. To prevent any damage, only remove the oven from its polystyrene foam base at the time of installation.

PREPARING THE HOUSING UNIT

- Kitchen units in contact with the oven must be heat resistant (min 90°C).
- Carry out all cabinet cutting work before fitting the oven in the housing and carefully remove all wood chips and sawdust.
- After installation, the bottom of the oven must no longer be accessible.
- For correct appliance operation, do not obstruct the minimum gap between the worktop and the upper edge of the oven.

ELECTRICAL CONNECTION

Make sure the power voltage specified on the appliance dataplate is the same as the mains voltage. The dataplate is on the front edge of the oven (visible when the door is open).

- Power cable replacement (type H05 RR-F 3 x 1.5 mm²) must be carried out by a qualified electrician. Contact an authorized service centre.

GENERAL RECOMMENDATIONS

Before use:

- Remove cardboard protection pieces, protective film and adhesive labels from accessories.
- Remove the accessories from the oven and heat it at 200° for about an hour to eliminate the smell and fumes from the insulating materials and protective grease.

During use:

- Do not place heavy objects on the door as they could damage it.
- Do not cling to the door or hang anything from the handle.
- Do not cover the inside of the oven with aluminium foil.
- Never pour water into the inside of a hot oven; this could damage the enamel coating.
- Never drag pots or pans across the bottom of the oven as this could damage the enamel coating.
- Make sure that the electrical cables of other appliances do not touch hot parts of the oven or become trapped in the door.
- Do not expose the oven to atmospheric agents.

SAFEGUARDING THE ENVIRONMENT

Disposal of packing material

The packing material is 100% recyclable and is marked with the recycle symbol (♻️). The various parts of the packing must therefore be disposed of responsibly and in full compliance with local authority regulations governing waste disposal.

Scrapping the product

- This appliance is marked in compliance with European Directive 2002/96/EC, Waste Electrical and Electronic Equipment (WEEE).
- By ensuring this product is disposed of correctly, you will help prevent potential negative consequences for the environment and human health, which could otherwise be caused by inappropriate waste handling of this product.
- The symbol  on the product or on the accompanying documentation indicates that it should not be treated as domestic waste but must be taken to an appropriate collection centre for the recycling of electrical and electronic equipment.

Energy saving

- Only pre-heat the oven if specified in the cooking table or your recipe.
- Use dark lacquered or enamelled baking moulds as they absorb heat far better.
- Switch the oven off 10/15 minutes before the set cooking time. Food requiring prolonged cooking will continue to cook even once the oven is switched off.

DECLARATION OF CONFORMITY (C E)

- This oven, which is intended to come into contact with foodstuffs, complies with European Regulation (C E) n.1935/2004 and has been designed, manufactured and sold in conformity with the safety requirements of the "Low Voltage" directive 2006/95/CE (which replaces 73/23/CEE and subsequent amendments), the protection requirements of "EMC" 2004/108/CE.

TROUBLESHOOTING GUIDE

The oven does not work:

- Check for the presence of mains electrical power and if the oven is connected to the electrical supply.
- Turn off the oven and restart it to see if the fault persists.

The door will not open:

- Turn off the oven and restart it to see if the fault persists.
- **Important:** during self-cleaning, the oven door will not open. Wait until it unlocks automatically (see paragraph "Cleaning cycle of ovens with pyrolysis function").

The electronic programmer does not work:

- If the display shows the letter "F" followed by a number, contact your nearest After-sales Service. Specify in this case the number that follows the letter "F".

AFTER-SALES SERVICE

Before calling the After-Sales Service:

1. See if you can solve the problem yourself with the help of the suggestions given in the "Troubleshooting guide".
2. Switch the appliance off and back on again to see if the fault persists.

If after the above checks the fault still occurs, get in touch with the nearest After-sales Service.

Always specify:

- a brief description of the fault;
- the type and exact model of the oven;
- the service number (number after the word Service on the rating plate), located on the right hand edge of the oven cavity (visible when the oven door is open). The service number is also indicated on the guarantee booklet;
- your full address;
- your telephone number.

SERVICE 0000 000 00000



If any repairs are required, please contact an authorised **After-sales Service** (to guarantee that original spare parts will be used and repairs carried out correctly).

CLEANING



WARNING

- **Never use steam cleaning equipment.**
- **Only clean the oven when it is cool to the touch.**
- **Disconnect the appliance from the power supply.**

Oven exterior

IMPORTANT: do not use corrosive or abrasive detergents. If any of these products accidentally comes into contact with the appliance, clean immediately with a damp microfibre cloth.

- Clean the surfaces with a damp microfibre cloth. If it is very dirty, add a few drops of washing up detergent to the water. Finish off with a dry cloth.

Oven interior

IMPORTANT: do not use abrasive sponges or metallic scrapers or scourers. Over time, these can ruin enamelled surfaces and the oven door glass.

- After every use, allow the oven to cool then clean it preferably while it is still warm in order to remove built-up dirt and stains caused by food residues (e.g. food with a high sugar content).
- Use proprietary oven detergents and follow the manufacturer's instructions to the letter.
- Clean the door glass with a suitable liquid detergent. The oven door can be removed to facilitate cleaning (see MAINTENANCE).
- The top heating element of the grill (see MAINTENANCE) can be lowered (some models only) to clean the roof of the oven.

N.B.: during prolonged cooking of foods with a high water content (e.g. pizza, vegetables, etc.) condensation may form on the inside of the door and around the seal. When the oven is cold, dry the inside of the door with a cloth or sponge.

Accessories:

- Soak the accessories in water with washing up detergent immediately after use, handling them with oven gloves if still hot.
- Food residues can be easily removed using a brush or sponge.

Cleaning the rear wall and catalytic side panels of the oven (if present):

IMPORTANT: do not use corrosive or abrasive detergents, coarse brushes, pot scourers or oven sprays which could damage the catalytic surface and ruin its self-cleaning properties.

- Operate the oven empty with the fan-assisted function at 200°C for about one hour
- Next, leave the appliance to cool down before removing any food residue with a sponge.

MAINTENANCE

WARNING

- Use protective gloves.
- Ensure the oven is cold before carrying out the following operations.
- Disconnect the appliance from the power supply.

REMOVING THE DOOR

To remove the door:

1. Open the door fully.
2. Lift the catches and push them forwards as far as they will go (fig. 1).
3. Close the door as far as it will go (A), lift it up (B) and turn it (C) until it is released (D) (fig. 2).

To refit the door:

1. Insert the hinges in their seats.
2. Open the door fully.
3. Lower the two catches.
4. Close the door.

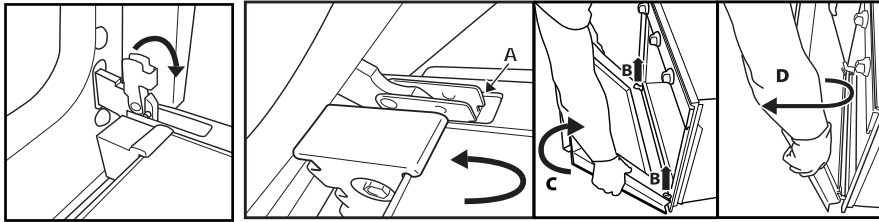

Fig. 1

Fig. 2

MOVING THE TOP HEATING ELEMENT (SOME MODELS ONLY)

1. Remove the side accessory holder grilles (Fig. 3).
2. Pull the heating element out a little (Fig. 4) and lower it (Fig. 5).
3. To reposition the heating element, lift it up, pulling it slightly towards you, making sure it comes to rest on the lateral supports.

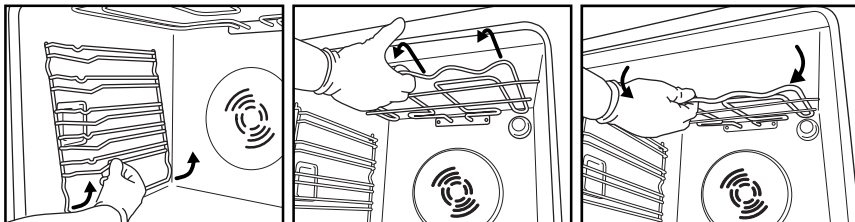

Fig. 3

Fig. 4

Fig. 5

REPLACING THE OVEN LAMP

To replace the rear lamp (if present):

1. Disconnect the oven from the power supply.
2. Unscrew the lamp cover (Fig. 6), replace the lamp (see note for lamp type) and screw the lamp cover back on.
3. Reconnect the oven to the power supply.

To replace the side lamp (if present):

1. Disconnect the oven from the power supply.
2. Remove the side accessory holder grilles, if present (Fig. 3).
3. Use a screwdriver to prise off the lamp cover (Fig. 7).
4. Replace the lamp (see note for lamp type) (Fig. 8).
5. Reposition the lamp cover, pushing it on firmly until it snaps into place (Fig. 9).
6. Refit the side accessory holder grilles.
7. Reconnect the oven to the power supply.

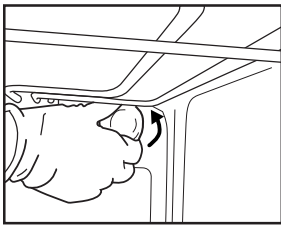

Fig. 6

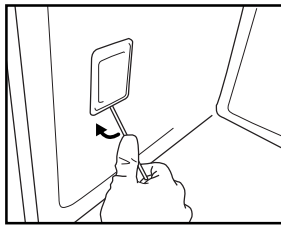

Fig. 7

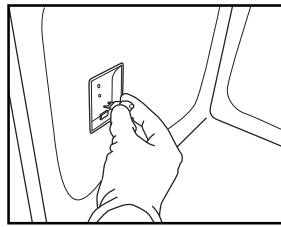

Fig. 8

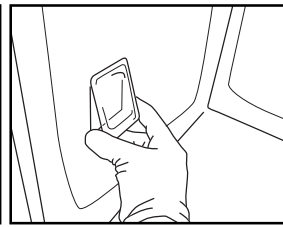

Fig. 9

N.B.:

- Only use 25-40W/230V type E-14, T300°C incandescent lamps, or 20-40W/230 V type G9, T300°C halogen lamps.
- The lamp used in the appliance is specifically designed for electrical appliances and is not suitable for household room illumination (Commission Regulation (EC) No 244/2009).
- Lamps are available from our After-sales Service.

IMPORTANT:

- **If using halogen lamps, do not handle with bare hands since fingerprints can damage them.**
- **Do not use the oven until the lamp cover has been repositioned.**

INSTRUCTIONS FOR OVEN USE

FOR THE ELECTRICAL CONNECTION, SEE THE SECTION ON INSTALLATION

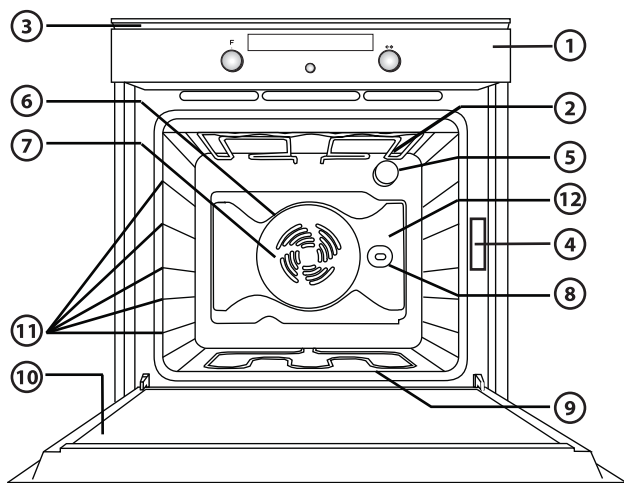

1. Control panel
2. Upper heating element/grill
3. Cooling fan (not visible)
4. Dataplate (not to be removed)
5. Lamp
6. Circular heating element (not visible)
7. Fan
8. Turnspit (if provided)
9. Lower heating element (not visible)
10. Door
11. Position of shelves (the level number is indicated on the front of the oven)
12. Rear wall

N.B.:

- During cooking, the cooling fan may switch on intermittently in order to reduce energy consumption.
- At the end of cooking, after the oven has been switched off, the cooling fan may continue to run for a while.
- When the oven door is opened during cooking, the heating elements switch off.

ACCESSORIES SUPPLIED

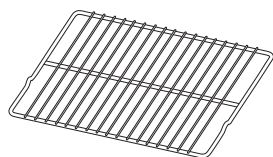

Fig. A

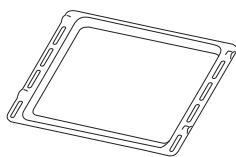

Fig. B

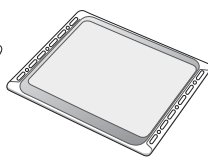

Fig. C

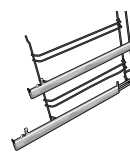

Fig. D

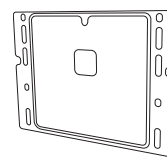

Fig. E

- A. RACK:** use to cook food or as a support for pots, cake tins and other suitable cooking receptacles.
- B. DRIP-TRAY:** use, placed under the rack, to collect fat or as a plate for cooking meat, fish, vegetables, focaccia, etc.
- C. BAKING TRAY:** use for bakery and pastry products, but also roasts, fish en papillote, etc.
- D. RUNNERS:** to facilitate insertion and removal of accessories.
- E. CATALYTIC PANELS:** for easier and more thorough cleaning of the oven walls.

The number of accessories may vary according to which model is purchased.

ACCESSORIES NOT SUPPLIED

Other accessories can be purchased separately from the After-sales Service.

INSERTING WIRE SHELVES AND OTHER ACCESSORIES IN THE OVEN

1. Insert the wire shelf horizontally, with the raised part "A" upwards (Fig. 1).
2. The other accessories, like the drip tray and baking tray, are inserted with the raised part on the flat section "B" facing upwards (Fig. 2).

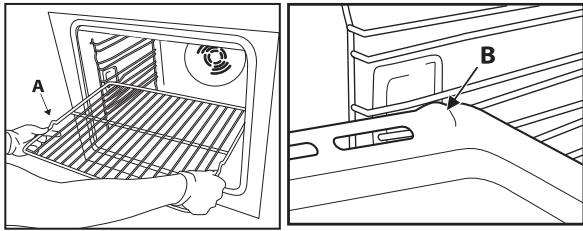
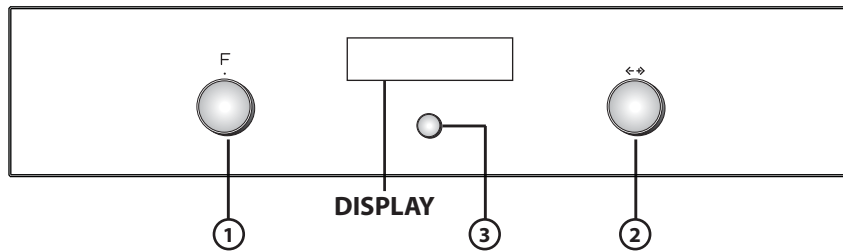

Fig. 1

Fig. 2

DESCRIPTION OF CONTROL PANEL

ELECTRONIC PROGRAMMER



1. **FUNCTIONS KNOB:** On/Off and function selection
 2. **BROWSE KNOB:** for browsing the menu and adjusting pre-set values
- N.B.: The knobs are retractable. Press the knobs in the middle and they pop up.**
3. **SELECTION/CONFIRMATION BUTTON**
- N.B.: The display shows ✓ for indications relevant to this button.**

LIST OF FUNCTIONS

Turn the "Functions" knob to any position and the oven switches on: the display shows the functions or their associated submenus.

The submenus are available and selectable by turning the knob to the functions GRILL, SPECIALS, SETTINGS, BREAD/PIZZA.

N.B.: For the list and description of functions, refer to the specific table on page 14.

DESCRIPTION OF DISPLAY

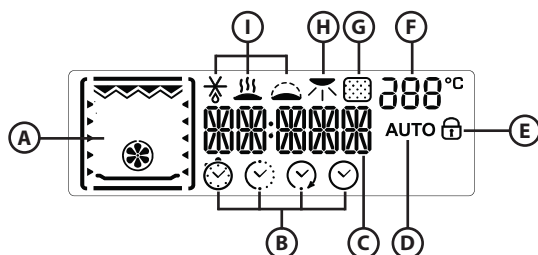

- A. Display of heating elements active during the various functions
- B. Time management symbols: timer, cooking duration, cooking end time, current time
- C. Information regarding selected functions
- D. Automatic BREAD/PIZZA function selected
- E. Indication of oven door closed during the automatic cleaning cycle (not available on this model)
- F. Oven inside temperature
- G. Pyrolysis function (not available on this model)
- H. Browning
- I. Special functions: Defrost, Keep Warm, Rising, Eco Forced Air

STARTING THE OVEN - SETTING THE LANGUAGE

At the first switch on of the oven, display shows ENGLISH. Turn the "Browse" knob until the desired language is displayed then press the button (3) to confirm.

SETTING THE CURRENT TIME

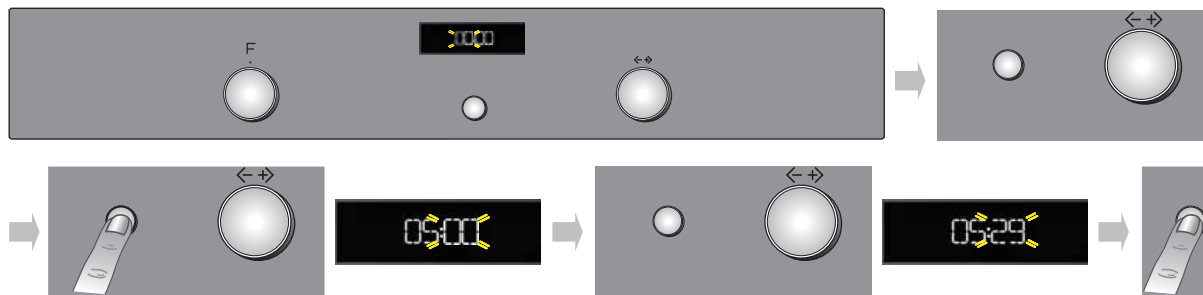

After setting the language, the current time must be set. The two hour digits flash on the display.

1. Turn the "Browse" knob to display the correct hour.
2. Press the button (3) to confirm; the two minute digits flash on the display.
3. Turn the "Browse" knob to display the correct minutes.
4. Press button (3) to confirm.

To change the current time, for example following a power outage, see the next section (SETTINGS).

SELECTING COOKING FUNCTIONS

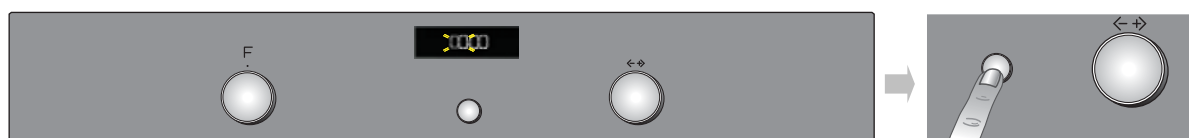

1. Turn the "Functions" knob to the required function: the cooking settings appear on the display.
2. If the parameters shown are those required, press (3). To modify them, proceed as indicated below.

SETTING THE TEMPERATURE/GRILL POWER

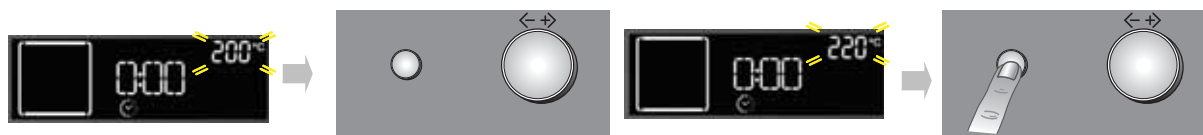

To modify the temperature or grill power, proceed as follows:

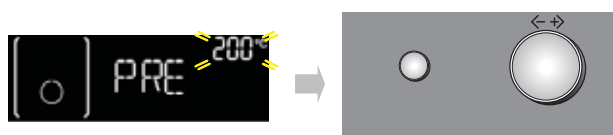

1. Turn the "Browse" knob to display the required value.
2. Press the button (3) to confirm.

RAPID PREHEATING





1. Turn the "Functions" knob to the symbol  to select the rapid preheating function.
2. Confirm by pressing (3): the settings appear on the display.
3. If the proposed temperature is that required, press the button (3). To modify it, proceed as described in the previous sections. The message **PRE** appears on the display. When the set temperature is reached, it will be replaced by the relevant value (e.g. 200°C) and an acoustic signal sounds. At the end of preheating, the oven automatically selects the conventional function .
4. To set a different cooking function, turn the "Functions" knob and select the required function.

SETTING THE COOKING DURATION

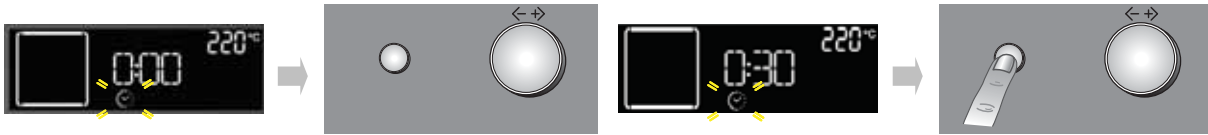
Use this function to cook food for a set time, from a minimum of 1 minute to the maximum time allowed by the selected function, after which the oven switches off automatically.



1. Once the temperature is confirmed, the symbol  flashes.
2. Turn the Adjustment knob to display the required cooking time.
3. To confirm the cooking time, press the button .

SETTING THE COOKING END TIME/DELAYED START

IMPORTANT: Delayed start setting is not available for the following functions: FAST PREHEATING, BREAD/PIZZA.

N.B.: With this setting, the selected temperature is reached in a more gradual way, therefore cooking times will be slightly longer than those given in the cooking table.

The required cooking end time can be set, delaying oven activation by up to a maximum of 23 hours and 59 minutes, starting from the current time. This is possible only after a cooking duration has been set.

After setting the cooking duration, the display shows the cooking end time (e.g. 15:45) and the symbol  flashes.

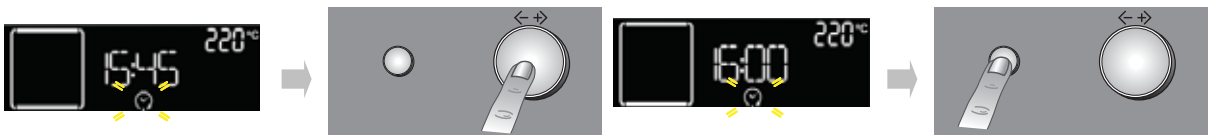



To delay the end of cooking, postponing oven activation, proceed as follows:

1. Turn the "Browse" knob to display the required time cooking is to end (e.g. 16:00).
2. Confirm the selected value by pressing button : the two dots of cooking end time flash, indicating that the setting has been made correctly.
3. The oven will automatically delay the start in order to end cooking at the set time.

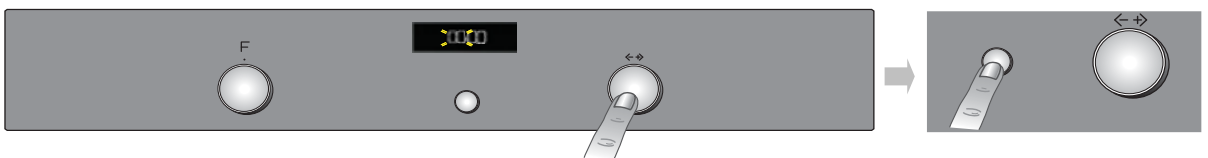
TIMER



This function can be used only with the oven switched off and is useful, for example, for controlling the cooking time of pasta. The maximum time that can be set is 23 hours and 59 minutes.



1. With the "Functions" knob on zero, turn the "Browse" knob to display the required time.
2. Press the button  to start the countdown. When the set time has elapsed, the display shows "END" and an acoustic signal sounds. To silence it, press the button  (the current time appears on the display).

SELECTING SPECIAL FUNCTIONS

Turn the "Functions" knob to the symbol  to access a submenu containing four special functions.

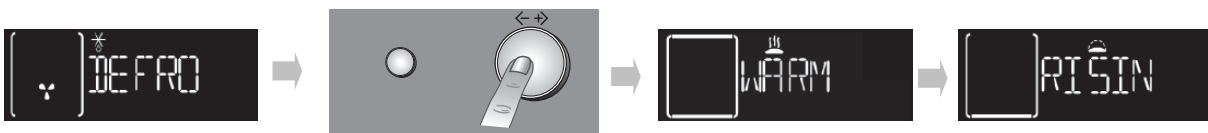
To browse, select and start one of these functions, proceed as follows:



1. Turn the "Functions" knob to the symbol : the display shows "DEFROST" and the symbol associated with this function.
2. Turn the "Browse" knob to scroll the list of functions: DEFROST, KEEP WARM, RISING, ECO FORCED AIR.
3. Press the button  to confirm.

BROWNING

At the end of cooking, with certain functions, the display indicates the possibility of extra browning. This function can only be used when a cooking duration has been set.

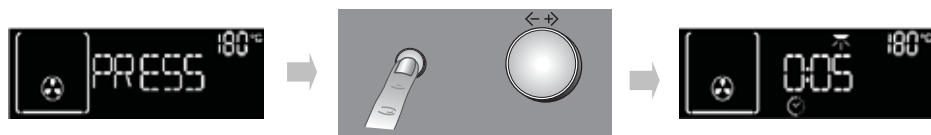

At the end of the cooking time, the display shows: "PRESS ✓✓ TO BROWN". Press the button ③, and the oven starts the 5 minute browning phase. This function can only be carried out twice.

BREAD/PIZZA FUNCTION SELECTION

Turn the "Functions" knob to the symbol  to access a submenu containing two automatic cooking functions for "bread" and "pizza".

Bread



1. Turn the "Functions" knob to the symbol : the display shows "BREAD" and AUTO alongside.
2. Press ③ to select the function.
3. Turn the "Browse" knob to set the required temperature (between 180°C and 220°C) and confirm with the button ③.
4. Turn the "Browse" knob to set the required cooking duration and press ③ to start baking.

Pizza



1. Turn the "Functions" knob to the symbol : the display shows "BREAD". To select the "PIZZA" function, proceed as follows:
2. Turn the "Browse" knob: "PIZZA" appears on the display.
3. Press ③ to select the function.
4. Turn the "Browse" knob to set the required temperature (between 220°C and 250°C) and confirm with the button ③.
5. Turn the "Browse" knob to set the required cooking duration and press ③ to start baking.

SETTINGS

Turn the "Functions" knob to the symbol  to access a submenu containing five display settings which can be modified.

Language

1. Turn the "Browse" knob to display "LANGUAGE".
2. Press ③ to access the setting.
3. Turn the "Browse" knob to select the desired language and confirm by pressing button ③

Clock

Turn the "Browse" knob to display CLOCK. To change the time, see the previous section (SETTING THE CURRENT TIME).

Eco

With the ECO mode selected (ON), the display reduces the brightness, showing the clock when the oven is on standby position from 3 minutes. Also, the oven light is switched off during cooking. To view information on the display and switch the light on again, just press the button ③ or turn one of the knobs.

1. Turn the "Browse" knob to display "ECO".
2. Press ③ to access the settings (ON/OFF).
3. Turn the "Browse" knob to select the required setting and confirm with the button ③.
4. During a cooking function if the Eco Mode is activated the cavity lamp will be switched off after 1 minute of cooking and reactivated for each user interaction.

Acoustic signal

To activate or deactivate the acoustic signal, proceed as follows:















1. Turn the "Browse" knob to display "SOUND".
2. Press ③ to access the settings (ON/OFF).
3. Turn the "Browse" knob to select the required setting and confirm by pressing the button ③.

Brightness









To modify the display brightness, proceed as follows:

















1. Turn the "Browse" knob to display "BRIGHTNESS".
2. Press the button ③: number 1 appears on the display.
3. Turn the "Browse" knob to increase or decrease the brightness and confirm with the button ③.







DESCRIPTION OF FUNCTIONS TABLE

FUNCTIONS KNOB		
	OFF	To stop cooking and switch off the oven.
	LAMP	To switch the oven light on/off.
	 DEFROST	To speed up defrosting of food. It is advisable to place food on the middle level. It is advisable to leave food in its packaging to prevent it from becoming dry on the outside.
	 KEEP WARM	For keeping just-cooked food (e.g. meat, fried food, flans) hot and crisp. It is advisable to place food on the middle level. The function will not activate if the temperature in the oven is above 65°.
	 RISING	For optimum rising of sweet or savoury dough. In order to preserve the quality of proving, the function will not activate if the temperature in the oven is above 40°C. Place dough on the 2nd level. The oven does not have to be preheated.
	 ECO FORCED AIR	To cook stuffed roasts and meat in pieces on one shelf. This function uses discontinuous, delicate fan assistance, which prevents excessive drying of foods. In this ECO function the light remains off during cooking and can be temporarily switched on again by pressing the confirm button. In order to maximize energy efficiency, it is advisable not to open the door during cooking. It is advisable to use 3rd level. The oven does not have to be preheated.
	CONVENTIONAL	To cook any type of dish on a single shelf. Use the 2nd level. Preheat the oven before placing food in it.
	CONVECTION BAKE	To cook meat and pies with liquid filling (savoury or sweet) on single shelf. Use 2nd shelf. Preheat the oven before cooking.
	FORCED AIR	To cook even different types of food (e.g. fish, vegetables, cakes), requiring the same cooking temperature, on two shelves at the same time. This function allows cooking without odours being transferred from one food to another. It is advisable to use the 2nd level to cook on a single shelf. To cook on two shelves, use the 1st and 3rd levels after preheating the oven.
	MAXI COOKING	To cook large joints of meat (more than 2.5 kg). Use the 1st or 2nd level, depending on the size of the meat. The oven does not have to be preheated. It is advisable to turn the meat over during cooking, to obtain even browning on both sides. It is preferable to baste the meat every now and again so that it does not become too dry.
	GRILL	For grilling steak, kebabs and sausages; vegetables au gratin and toasting bread. Place food on the 4th level. When grilling meat, it is advisable to use the drip-tray to collect the cooking juices. Place it on the 3rd level, adding approx. half a litre of water. The oven does not have to be preheated. During cooking, the oven door must remain closed.
	TURBO GRILL	For roasting large pieces of meat (legs, roast beef, chickens). Place the food on the middle levels. It is advisable to use the drip-tray to collect the cooking juices. Place it on the 1st/2nd level, adding approx. half a litre of water. The oven does not have to be preheated. During cooking, the oven door must remain closed. With this function it is also possible to use the turnspit, if provided.
	SETTINGS	To set the display (language, time, brightness, buzzer volume, energy saving).
	BREAD/PIZZA	To bake different types and sizes of pizza and bread. This function contains two programmes with predefined settings. Simply indicate the values required (temperature and time) and the oven will manage the cooking cycle automatically. Place the dough on the 2nd level after preheating the oven.
	FAST PREHEATING	To preheat the oven rapidly.

COOKING TABLE















Recipe	Function	Pre-heating	Shelf (from bottom)	Temp. (°C)	Time (min)	Accessories and notes
Leavened cakes		Yes	2	160-180	30-90	Cake tin on wire shelf
		Yes	1-3	160-180	30-90	Shelf 3: cake tin on wire shelf Shelf 1: cake tin on wire shelf
Filled pies (cheesecake, strudel, apple pie)		Yes	2	160-200	30-85	Drip tray/baking tray or cake tin on wire shelf
		Yes	1-3	160-200	35-90	Shelf 3: cake tin on wire shelf Shelf 1: cake tin on wire shelf
Biscuits / Tartlets		Yes	2	170-180	15-45	Drip tray / baking tray
		Yes	1-3	160-170	20-45	Shelf 3: wire shelf Shelf 1: drip tray / baking tray
Choux buns		Yes	2	180-200	30-40	Drip tray / baking tray
		Yes	1-3	180-190	35-45	Shelf 3: oven tray on wire shelf Shelf 1: drip tray / baking tray
Meringues		Yes	2	90	110-150	Drip tray / baking tray
		Yes	1-3	90	130-150	Shelf 3: oven tray on wire shelf Shelf 1: drip tray / baking tray
Bread / Pizza / Focaccia		Yes	2	190-250	15-50	Drip tray / baking tray
		Yes	1-3	190-250	25-50	Shelf 3: oven tray on wire shelf Shelf 1: drip tray / baking tray
Bread	 (Bread)	Yes	2	180-220	30-50	Drip-tray / baking tray or wire shelf
Pizza	 (Pizza)	Yes	2	220-250	15-30	Drip-tray / baking tray
Frozen pizza		Yes	2	250	10-15	Shelf 2: drip tray / baking tray or wire shelf
		Yes	1-3	250	10-20	Shelf 3: oven tray on wire shelf Shelf 1: drip tray / baking tray

Recipe	Function	Pre-heating	Shelf (from bottom)	Temp. (°C)	Time (min)	Accessories and notes
Savoury pies (vegetable pie, quiche)		Yes	2	180-190	35-45	Cake tin on wire shelf
		Yes	1-3	180-190	45-60	Shelf 3: cake tin on wire shelf Shelf 1: cake tin on wire shelf
Vols-au-vent / Puff pastry crackers		Yes	2	190-200	20-30	Drip tray / baking tray
		Yes	1-3	180-190	20-40	Shelf 3: oven tray on wire shelf Shelf 1: drip tray / baking tray
Lasagne / Baked pasta / Cannelloni / Flans		Yes	2	190-200	45-65	Drip tray or oven tray on wire shelf
Lamb / Veal / Beef / Pork 1 Kg		Yes	2	190-200	70-100	Drip tray or oven tray on wire shelf
Chicken / Rabbit / Duck 1 Kg		Yes	2	200-230	50-100	Drip tray or oven tray on wire shelf
Turkey / Goose 3 Kg		Yes	1/2	190-200	80-130	Drip tray or oven tray on wire shelf
Baked fish / en papillote (fillet, whole)		Yes	2	180-200	40-60	Drip tray or oven tray on wire shelf
Stuffed vegetables (tomatoes, courgettes, aubergines)		Yes	2	180-200	50-60	Oven tray on wire shelf
Toast		-	4	3 (high)	2-5	Wire shelf
Fish fillets / steaks		-	4	2 (medium)	20-35	Shelf 4: wire shelf (turn food halfway through cooking)
						Shelf 3: drip tray with water
Sausages / Kebabs / Spare ribs / Hamburgers		-	4	2-3 (medium - high)	15-40	Shelf 4: wire shelf (turn food halfway through cooking)
						Shelf 3: drip tray with water
Roast chicken 1-1.3 Kg		-	2	2 (medium)	50-65	Shelf 2: wire tray (turn food two thirds of the way through cooking)
				3 (high)	60-80	Shelf 1: drip tray with water Shelf 2: turnspit (if present) Shelf 1: drip tray with water
Roast Beef rare 1 Kg		-	2	2 (medium)	35-45	Oven tray on wire shelf (turn food two thirds of the way through cooking if necessary)
Leg of lamb / Shanks		-	2	2 (medium)	60-90	Drip tray or oven tray on wire shelf (turn food two thirds of the way through cooking if necessary)

Recipe	Function	Pre-heating	Shelf (from bottom)	Temp. (°C)	Time (min)	Accessories and notes
Roast potatoes		-	2	2 (medium)	45-55	Drip-tray / baking tray (if necessary, turn food two thirds of the way through cooking)
Vegetable gratin		-	2	3 (high)	10-15	Oven tray on wire shelf
Lasagna & Meat		Yes	1-3	200	50-100*	Shelf 3: oven tray on wire shelf Shelf 1: drip tray or oven tray on wire shelf
Meat & Potatoes		Yes	1-3	200	45-100*	Shelf 3: oven tray on wire shelf Shelf 1: drip tray or oven tray on wire shelf
Fish & Vegetables		Yes	1-3	180	30-50*	Shelf 3: oven tray on wire shelf Shelf 1: drip tray or oven tray on wire shelf
Filled roast meats		-	3	200	80-120*	Drip-tray or pan on rack
Meat cuts (rabbit, chicken, lamb)		-	3	200	50-100*	Drip-tray or pan on rack

*Cooking time is approximate. Food can be removed from the oven at different times depending on personal preference.

TESTED RECIPES in compliance with IEC 60350-1:2011-12 and DIN 3360-12:07:07

Recipe	Function	Pre-heating	Shelf (from bottom)	Temp. (°C)	Time (min)	Accessories and notes
IEC 60350-1:2011-12 § 7.5.2						
Shortbread **		Yes	2	170	15-25	Drip-tray / baking tray
		Yes	1-3	150	30-45	Level 3: baking tray Level 1: drip-tray / baking tray
IEC 60350-1:2011-12 § 7.5.3						
Small cakes **		Yes	3	170	20-30	Drip-tray / baking tray
		Yes	1-3	160	25-35	Level 3: baking tray Level 1: drip-tray / baking tray
IEC 60350-1:2011-12 § 7.6.1						
Fatless sponge cake**		Yes	2	170	30-40	Cake tin on wire shelf
		Yes	1-3	160	35-45	Shelf 3: cake tin on wire shelf Shelf 1: cake tin on wire shelf
IEC 60350-1:2011-12 § 7.6.2						
Two apple pies **		Yes	2	185	60-75	Cake tin on wire shelf
		Yes	1-3	175	70-90	Level 3: cake tin on wire shelf Level 1: cake tin on wire shelf
IEC 60350-1:2011-12 § 9.2						
Toast *		-	4	3 (high)	3-5	Wire shelf
IEC 60350-1:2011-12 § 9.3						
Burgers *		-	4	3 (high)	30-40	Level 4: wire shelf (turn food halfway through cooking) Level 3: drip-tray with water
DIN 3360-12:07 § 6.5.2.3						
Apple cake, yeast tray cake		Yes	2	180	30-40	Drip-tray / baking tray
		Yes	1-3	160	55-65	Level 3: baking tray Level 1: drip-tray / baking tray
DIN 3360-12:07 § 6.6						
Roast pork		-	2	170	110-150	Level 2: drip-tray
DIN 3360-12:07 annex C						
Flat cake **		Yes	2	170	35-45	Drip-tray / baking tray
		Yes	1-3	170	40-50	Level 3: baking tray Level 1: drip-tray / baking tray

** The cooking table suggests the ideal functions and cooking temperatures for obtaining the best results with any type of recipe. For fan oven cooking on a single level it is advisable to use the second shelf and the same temperature suggested for the "FORCED AIR"  function on more than one level.

The indications in the table are without use of the runners. Do the tests without the runners.

* When grilling, it is advisable to leave a space of 3-4 cm at the front to facilitate removal.

Energy efficiency class (according to EN 60350-1:2013-07)

To do the test, use the dedicated table.

TIPS AND ADVICE

How to read the cooking table

The table indicates the best function to use for a given food, to be cooked on one or more shelves at the same time. Cooking times start from the moment food is placed in the oven, excluding preheating (when required). The cooking temperatures are only a guide and depend on the amount of food and type of accessory used. Use the lowest recommended values to begin with and if cooking results are not those desired, use higher values. Use the accessories supplied and preferably dark coloured metal cake tins and pans. Pots and accessories in Pyrex or ceramic can also be used, but cooking times will be slightly longer. To obtain best results, carefully follow the advice given in the cooking table for the choice of accessories (supplied) to be placed on the various shelves.

Cooking different foods at the same time

Using the "FORCED AIR" function, different foods (e.g. fish and vegetables) requiring the same temperature can be cooked on different shelves at the same time. Remove the food requiring shorter cooking times and leave food requiring longer times to continue cooking.

Cakes

- Bake delicate cakes with the conventional function on a single level. Use dark coloured metal cake tins and always place them on the rack provided. To bake on more than one level, select the forced air function and stagger the position of cake tins on the racks, to favour circulation of the air.
- To check if a raising cake is baked, insert a toothpick into the top of the cake. If the toothpick comes out dry, the cake is ready.
- When using non-stick cake tins, do not butter the edges, as the cake may not rise evenly at the edges.
- If the cake "sinks" during baking, set a lower temperature the next time, even reducing the amount of liquid and mixing more gently.
- Cakes with juicy fillings (cheesecake or fruit pies) require the "CONVECTION BAKE" function. If the base of the cake is too soggy, lower the shelf and sprinkle the bottom of the cake with breadcrumbs or biscuit crumbs before adding the filling.

Meat

- Use any type of pan or baking dish suitable for the size of the piece of meat being cooked. For roasts, it is advisable to add a little stock on the bottom of the pan, basting the meat during cooking to give it flavour. When the roast is ready, leave it in the oven for another 10-15 minutes, or wrap it in aluminium foil.
- To grill pieces of meat, choose cuts having the same thickness in order to obtain even cooking. Very thick pieces of meat require longer cooking times. To prevent the meat from burning on the outside, place the rack on a lower level, keeping it further away from the grill. Turn the meat two thirds of the way through cooking.

To collect the cooking juices it is advisable to place a drip-tray with half a litre of water directly under the rack on which the meat is placed. Top-up when necessary.

Turnspit (provided only in some models)

Use this accessory to roast large pieces of meat and poultry evenly. Place the meat on the turnspit rod, tying it with string if chicken, and check that it is secure before inserting the rod in the seat located on the front wall of the oven and resting it on the respective support. To prevent smoke and to collect cooking juices, it is advisable to place a drip-tray with half a litre of water on the first level. The rod has a plastic handle which must be removed before starting to cook, and used at the end of cooking to avoid burns when taking the food out of the oven.

Pizza

Lightly grease the pans to obtain a pizza with a crispy base. Sprinkle the mozzarella over the pizza two thirds of the way through cooking.

Rising function

It is advisable to always cover the dough with a damp cloth before placing it in the oven. Rising times with this function are reduced by about a third compared to proving at room temperature (20-25°C). The rising time for 1 kg of pizza dough is about one hour.



Printed in Italy
11/2011

5019 300 02999



Free Manuals Download Website

<http://myh66.com>

<http://usermanuals.us>

<http://www.somanuals.com>

<http://www.4manuals.cc>

<http://www.manual-lib.com>

<http://www.404manual.com>

<http://www.luxmanual.com>

<http://aubethermostatmanual.com>

Golf course search by state

<http://golfingnear.com>

Email search by domain

<http://emailbydomain.com>

Auto manuals search

<http://auto.somanuals.com>

TV manuals search

<http://tv.somanuals.com>