

Use & Care

G U I D E

Top-Mount
Refrigerator

M A N U A L D E

Uso Y Cuidado

Refrigerador
con
Congelador Arriba

Table of Contents2
Contenido26

TABLE OF CONTENTS

	Page
A Note to You	2
Refrigerator Safety	3
Proper Disposal of Your Old Refrigerator	4
Parts and Features	5
Installing Your Refrigerator	6
Unpacking your refrigerator	6
Space requirements	6
Electrical requirements	7
Door closing and alignment.....	8
Using Your Refrigerator	9
Setting the control	9
Changing the control settings.....	9
Ensuring proper air circulation.....	10
Removing the drop-in door trim.....	10
Adjusting the refrigerator shelves.....	11
Removing the crisper and crisper cover	11
Removing the meat drawer and cover	12
Adjusting the freezer shelf.....	13
Changing the light bulb.....	13
Reversing the door swing	14
Understanding the sounds you may hear.....	16
Saving energy.....	16
Caring for Your Refrigerator	17
Cleaning your refrigerator.....	17
Holiday and moving care	19
Power interruptions.....	20
Food Storage Guide	21
If You Need Assistance or Service	23
Warranty	24

A NOTE TO YOU

Thank you for buying a WHIRLPOOL® appliance.

The Whirlpool Brand is committed to designing quality products that consistently perform for you to make your life easier. To ensure that you enjoy years of trouble-free operation, we developed this Use and Care Guide. It is full of valuable information about how to operate and maintain your appliance properly and safely. Please read it carefully.

Record your model's information

Write down the following information about your refrigerator to better help you obtain assistance or service if you ever need it. You will need to know your complete model number and serial number. You can find this information on the model and serial number label/plate.

If you need assistance or service, first see the "Troubleshooting" section of this book. After checking "Troubleshooting," additional help can be found by checking the "Requesting Assistance or Service" section.

Dealer name _____

Address _____

Phone number _____

Model number _____

Serial number _____

Purchase date _____

(See the "Parts and Features" section for model and serial number label/plate location.)

Keep this book and your sales slip together for future reference.

REFRIGERATOR SAFETY

YOUR SAFETY AND THE SAFETY OF OTHERS IS VERY IMPORTANT.

We have provided many important safety messages in this manual and on your appliance. Always read and obey all safety messages.



This is the safety alert symbol.

This symbol alerts you to hazards that can kill or hurt you and others.

All safety messages will be preceded by the safety alert symbol and the word "DANGER" or "WARNING." These words mean:

⚠ DANGER

You will be killed or seriously injured if you don't follow instructions.

⚠ WARNING

You can be killed or seriously injured if you don't follow instructions.

All safety messages will identify the hazard, tell you how to reduce the chance of injury, and tell you what can happen if the instructions are not followed.

IMPORTANT SAFETY INSTRUCTIONS

WARNING: To reduce the risk of fire, electric shock, or injury when using your refrigerator, follow these basic precautions:

- Plug into a grounded (earthed) outlet.
- Do not remove ground prong.
- Do not use an adapter.
- Do not use an extension cord.
- Disconnect power before servicing.
- Replace all panels before operating.
- Remove doors from your old refrigerator.
- Use nonflammable cleaner.
- Keep flammable materials and vapors, such as gasoline, away from refrigerator.
- Use two or more people to move and install refrigerator.
- Unplug refrigerator before installing ice maker.
- Use a sturdy glass when dispensing ice or water (on some models).

SAVE THESE INSTRUCTIONS

PROPER DISPOSAL OF YOUR OLD REFRIGERATOR

! WARNING

Suffocation Hazard

Remove doors from your old refrigerator.

Failure to do so can result in death or brain damage.

IMPORTANT: Child entrapment and suffocation are not problems of the past. Junked or abandoned refrigerators are still dangerous... even if they will sit for “just a few days.” If you are getting rid of your old refrigerator, please follow the instructions below to help prevent accidents.

BEFORE YOU THROW AWAY YOUR OLD REFRIGERATOR OR FREEZER:

- Take off the doors.
- Leave the shelves in place so that children may not easily climb inside.

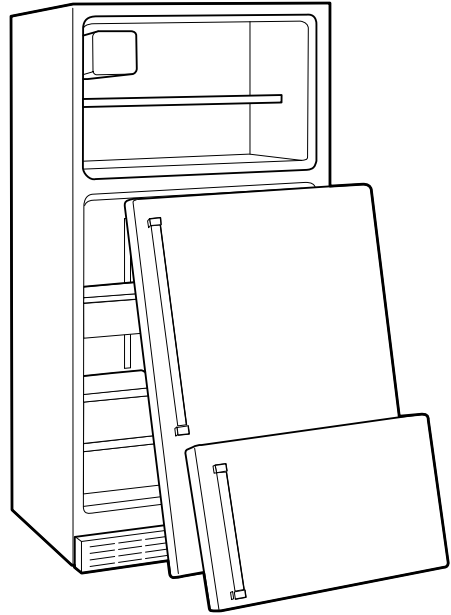

PARTS AND FEATURES

This section contains captioned illustrations of your appliance. Use them to become familiar with where all parts and features are located and what they look like.

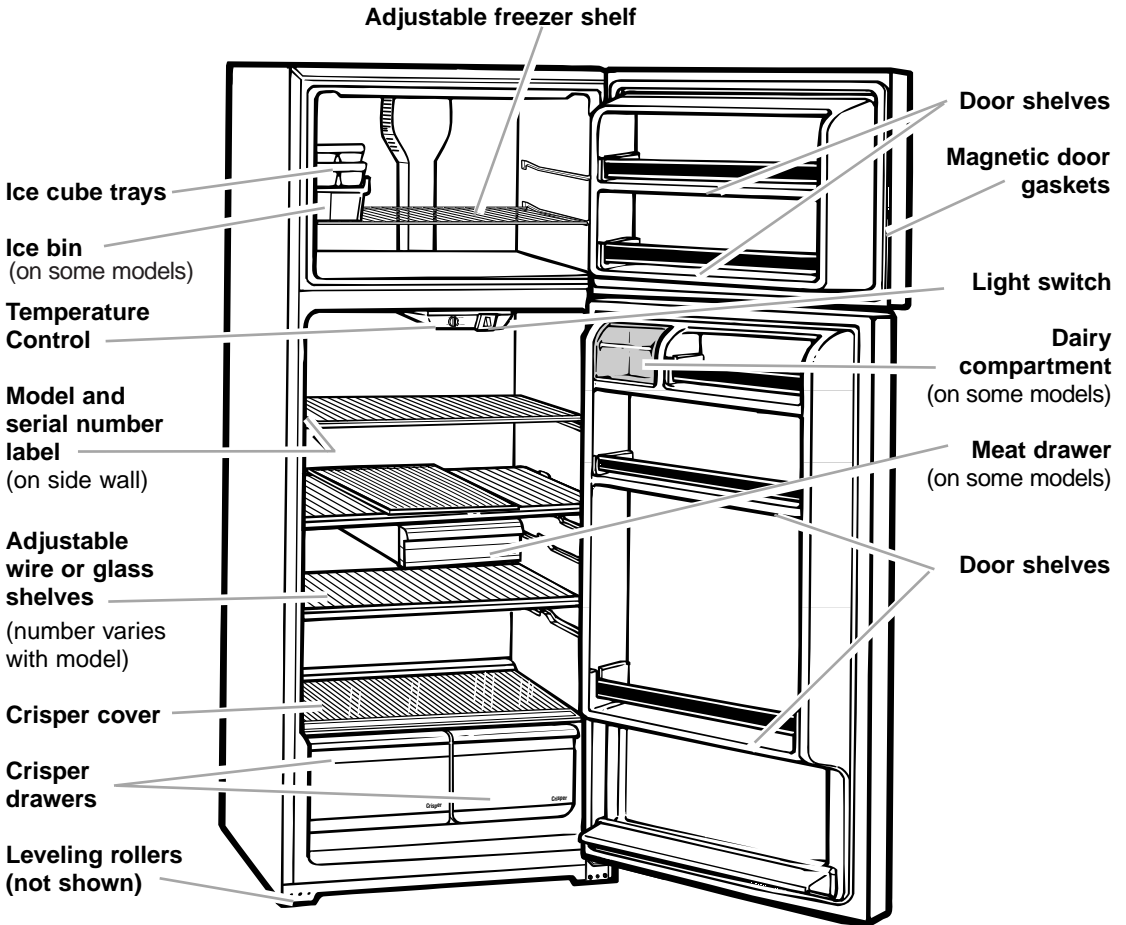

Other parts and features

(not shown in illustration above/optional on some models)

Full-width crisper drawer

Glass crisper cover

INSTALLING YOUR REFRIGERATOR

It is important to prepare your refrigerator for use. This section tells you how to clean it, install it, connect it to a power source, and level it.

UNPACKING YOUR REFRIGERATOR

! WARNING

Excessive Weight Hazard

Use two or more people to move and install refrigerator.

Failure to do so can result in back or other injury.

Removing packaging materials

- Remove tape and any labels from your refrigerator before using (except the model and serial number label).
- To remove any remaining tape or glue, rub the area briskly with your thumb. Tape or glue residue can also be easily removed by rubbing a small amount of liquid dish soap over the adhesive with your fingers. Wipe with warm water and dry.
- Do not use sharp instruments, rubbing alcohol, flammable fluids, or abrasive cleaners to remove tape or glue. These products can damage the surface of your refrigerator. For more information, see "Important Safety Instructions" in the "Refrigerator Safety" section.

IMPORTANT:

- Do not remove any permanent instruction labels inside your refrigerator.

Cleaning before use

After you remove all of the packaging materials, clean the inside of your refrigerator before using it. See the cleaning instructions in the "Caring For Your Refrigerator" section for more information.

SPACE REQUIREMENTS

! WARNING



Explosion Hazard

Keep flammable materials and vapors, such as gasoline, away from refrigerator.

Failure to do so can result in death, explosion or fire.

- Allow 7.5 cm (3 inches) between the overhead cabinets and the refrigerator top, and allow 1.25 cm ($\frac{1}{2}$ inch) on each side.
- Allow at least 2.5 cm (1 inch) between the refrigerator condenser on the back and the wall.
- If you are installing your refrigerator next to a fixed wall, leave 5 cm (2 inches) minimum on the hinge side (depending on your model) to allow for the door to swing open.

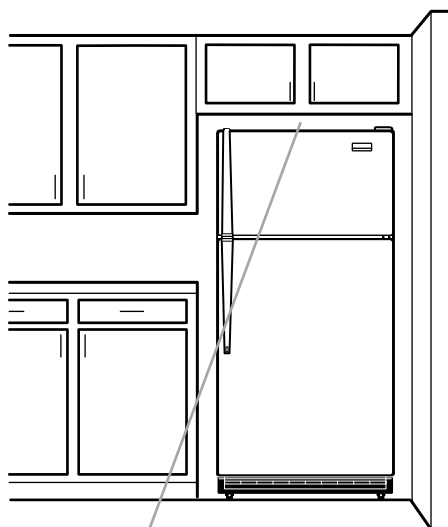

7.5 cm (3-inch) minimum at top and 1.25 cm ($\frac{1}{2}$ -inch) minimum at sides

ELECTRICAL REQUIREMENTS

⚠ WARNING



Electrical Shock Hazard

Plug into a grounded (earthed) outlet.

Do not remove ground prong.

Do not use an adapter.

Do not use an extension cord.

Failure to follow these instructions can result in death, fire, or electrical shock.

Before you move your refrigerator into its final location, it is important to make sure you have the proper electrical connection.

Recommended Grounding Method

Plug 1: A 115 Volt/60 Hz AC only 15 to 20 ampere fused and properly grounded (earthed) electrical supply is required.

Plugs 2 and 3: A 220/240 Volt/50 Hz or 220 Volt/60 Hz AC only 10 ampere fused and properly grounded (earthed) electrical supply is required.

NOTE: Before performing any type of installation, cleaning, or removing a light bulb, turn the Temperature Control to OFF and then disconnect the refrigerator from the electrical source. When you are finished, connect the refrigerator to the electrical source and reset the Temperature Control to the desired setting.

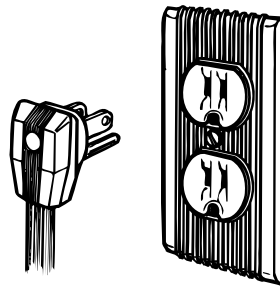

Plug 1

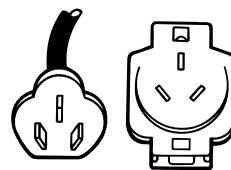

Plug 2

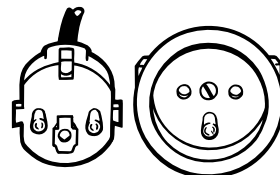

Plug 3

DOOR CLOSING AND ALIGNMENT

Door Closing

Your refrigerator has 2 front adjustable rollers - one on the right and one on the left. If your refrigerator seems unsteady or you want the doors to close easier, adjust the refrigerator's tilt using the instructions below:

1. Plug refrigerator power cord into a grounded (earthed) outlet. Move the refrigerator into its final position.
2. The two leveling screws are part of the front roller assemblies which are at the base of the refrigerator on either side.
3. Use a screwdriver to adjust the leveling screws. Turn the leveling screw to the right to raise that side of the refrigerator or turn the leveling screw to the left to lower that side. It may take several turns of the leveling screws to adjust the tilt of the refrigerator.

NOTE: Having someone push against the top of the refrigerator takes some weight off the leveling screws and rollers. This makes it easier to adjust the screws.

4. Open both doors again and check to make sure that they close as easily as you like. If not, tilt the refrigerator slightly more to the rear by turning both leveling screws to the right. It may take several more turns, and you should turn both leveling screws the same amount.

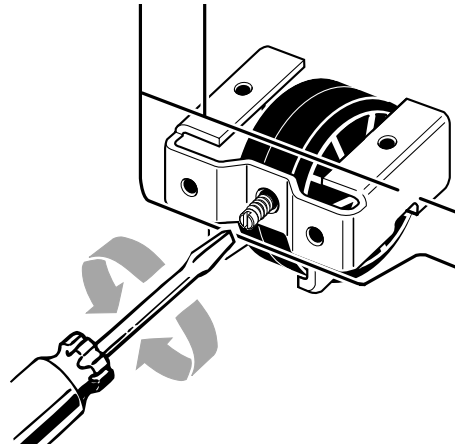

Door Alignment

If the space between your doors looks uneven, you can adjust it using the instructions below:

1. Pry off the top hinge cover.
2. Loosen the top hinge screws using a $\frac{5}{16}$ -inch socket or wrench.
3. Have someone hold the door in place or put a spacer between the doors while you tighten the top hinge screws.
4. Replace the top hinge cover.

USING YOUR REFRIGERATOR

SETTING THE CONTROL

The control for the refrigerator and freezer is located in the top of the refrigerator section. It controls the temperature in both the refrigerator and freezer compartments.

When you first install your refrigerator, set the Temperature Control to 3 (normal).

Temperature Control adjustments range from 1 (warmest) to 5 (coldest).

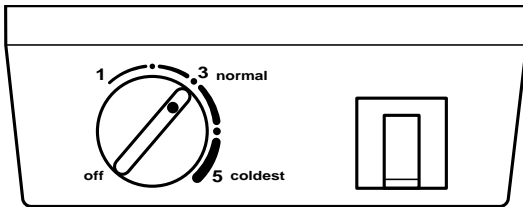

NOTES:

- The built-in exterior moisture control continuously guards against moisture build-up on the outside of the refrigerator cabinet.
- Turning the Temperature Control to **OFF** stops cooling in both the refrigerator and the freezer compartments, but does **not** disconnect the refrigerator from the power supply.

IMPORTANT: Give the refrigerator time to cool down completely before adding food. This could take several hours. If you add food before the refrigerator has cooled completely your food may spoil. Turning the control to a higher than recommended setting will not cool the compartment(s) any faster. The control settings indicated in “Changing the Control Settings” section should be correct for normal household refrigerator usage. The control is set correctly when milk or juice is as cold as you like and when ice cream is firm.

CHANGING THE CONTROL SETTINGS

If you need to adjust temperatures in the refrigerator or freezer, use the settings listed in the chart below as a guide. **Wait at least 24 hours between adjustments.**

Condition/ Reason:	RECOMMENDED ADJUSTMENT:
Refrigerator section too warm <ul style="list-style-type: none"> • Door opened often • Large amount of food added • Room temperature too warm 	Turn Temperature Control to next higher number
Freezer section too warm/ ice not made fast enough <ul style="list-style-type: none"> • Door opened often • Large amount of food added • Very cold room temperature (can't cycle often enough) • Heavy ice usage 	Turn Temperature Control to next higher number
Refrigerator section too cold <ul style="list-style-type: none"> • Control not set correctly for your conditions 	Turn Temperature Control to next lower number
Freezer section too cold <ul style="list-style-type: none"> • Control not set correctly for your conditions 	Turn Temperature Control to next lower number

ENSURING PROPER AIR CIRCULATION

In order to ensure proper temperatures, you need to permit air flow between the two sections. As shown in the illustration, cool air enters through the bottom of the freezer section (1) and moves up. Most of the air then flows through the freezer section vents (2) and recirculates under the freezer floor (3). The rest of the air enters the fresh section through the top vent (4).

Do not block any of these vents (1, 2, 3, or 4) with food packages. If the vents are blocked, air flow will be prevented and temperature and moisture problems may occur.

IMPORTANT: Because air circulates between both sections, any odors formed in one section will transfer to the other. You must thoroughly clean both sections to eliminate odors. To prevent odor transfer and drying out of food, wrap or cover foods tightly. (See the “Food Storage Guide” section for details.)

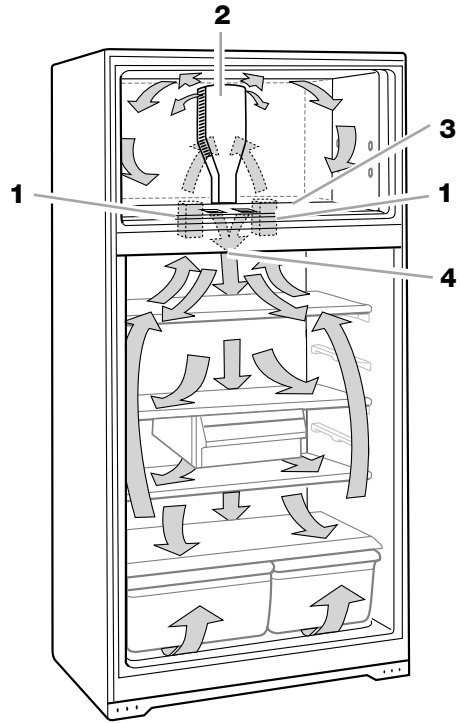

REMOVING THE DROP-IN DOOR TRIM

To remove the trim piece:

1. Remove all items from the shelf.
2. Pull straight up on each end of the trim piece.

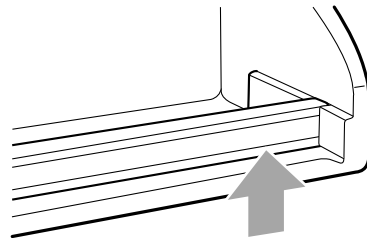

To replace the trim piece:

1. Locate each end of the trim piece above the trim pocket opening.
2. Push the trim ends straight down until they stop.
3. Replace items on the shelf.

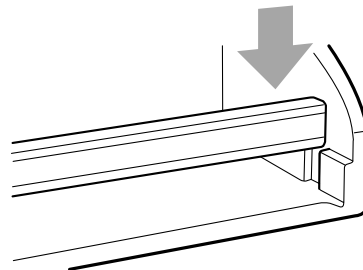

ADJUSTING THE REFRIGERATOR SHELVES

To remove the shelves:

1. Remove items from the shelf.
2. Slide shelf straight out to the stop.
3. Depending on your model, lift the back or front of the shelf over the stop.
4. Slide shelf out the rest of the way.

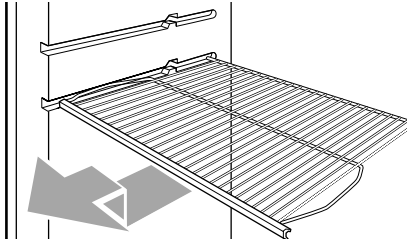

To replace the shelves:

1. Slide back of shelf into shelf track in wall of cabinet.
2. Guide front of shelf into shelf track.
3. Slide shelf in all the way.

REMOVING THE CRISPER(S) AND COVER

To remove the crisper(s):

1. Slide crisper(s) straight out to the stop.
2. Lift the front.
3. Slide out the rest of the way.
4. Replace in reverse order.

To remove the cover:

1. Lift cover front and remove the cover support.
2. Lift cover up and slide out.

STYLE 1

Lift cover front, then the back.

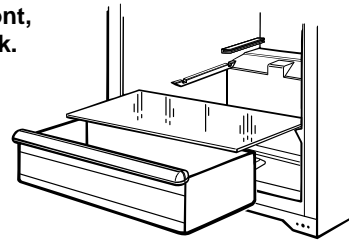

STYLE 2

Lift cover front, then the back.

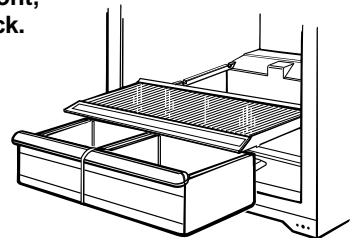

To replace the cover:

1. Fit cover tabs into lowest cabinet slots and push in. Lower the front retainers into place.
2. Insert cover support (with the long tab toward the front) into the groove on the underside of the cover.

NOTE: If the support needs adjustment, turn base clockwise to raise or counter-clockwise to lower.

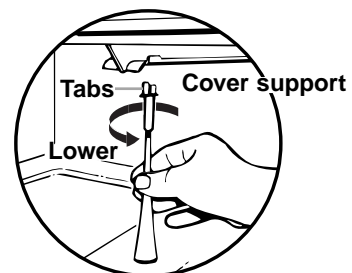

REMOVING THE MEAT DRAWER AND COVER (on some models)

To remove the meat drawer:

1. Slide meat drawer out to the stop.
2. Lift front of meat drawer.
3. Slide meat drawer out the rest of the way.
4. Replace in reverse order.

Style 1

To remove the cover:

1. Remove meat drawer.
2. Push cover back to release rear clips from shelf.
3. Tilt cover up at front.
4. Pull cover forward and out.

To replace the cover:

1. Fit notches and clips on underside of cover over rear and center cross bars on shelf.
2. Lower cover into place.
3. Pull cover forward to secure rear clips onto shelf.
4. Replace meat drawer.

Style 2

To remove the cover:

1. Remove meat drawer.
2. Take the half width cover with both hands, lift up the shelf side resting on the side wall of the refrigerator.
3. Turn the cover toward the opposite side wall.
4. Tilt the cover up at front, then tilt cover up at back until rear hook is out of the center shelf support and pull cover toward you.

To replace the cover:

1. Guide the rear cover hooks into the slot of the center support.
2. Tilt the front of the cover up until rear hook drops into slot.
3. Rest cover on side wall.
4. Make sure shelf is firmly supported.

Style 1

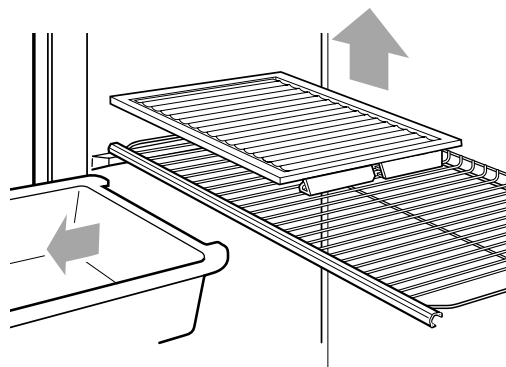

Style 2

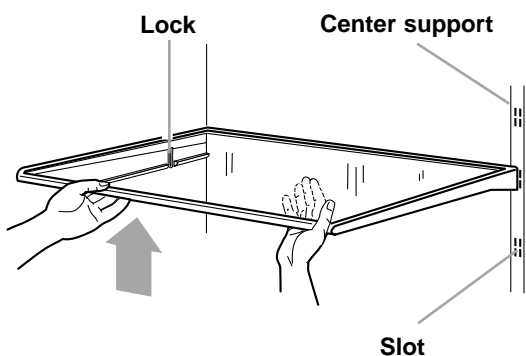

ADJUSTING THE FREEZER SHELF (on some models)

To remove the shelf:

1. Remove items from the shelf.
2. Lift back of shelf over stop.
3. Slide shelf straight out.

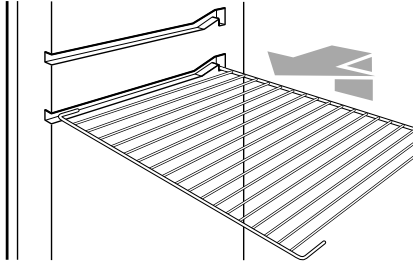

To replace the shelf:

1. Slide back of shelf into shelf tracks on walls of cabinet.
2. Slide shelf in all the way.

CHANGING THE LIGHT BULB

To change the refrigerator light:

1. Unplug refrigerator or disconnect power.
2. Reach behind the Control Panel and remove the bulb.
3. Replace the bulb with a 40-watt appliance bulb.
4. Plug in refrigerator or reconnect power.

NOTE: Not all appliance bulbs will fit your refrigerator. Be sure to replace the bulb with one of the same size and shape.

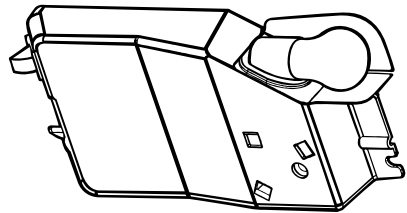

REVERSING THE DOOR SWING

SUGGESTION: Reversing the door swing should be performed by a qualified person.

IMPORTANT INFORMATION:

- Before you begin, turn refrigerator OFF, unplug it, and remove any food from door shelves.
- When removing hinges, keep doors closed until ready to lift free from cabinet.
- To remove doors, start at the top hinge and work your way down.
- To replace doors, start at the bottom hinge and work your way up.
- Line up doors so they are centered between the sides of the cabinet **and** parallel with each other.
- Seal all unused openings with screws or plastic plugs. Moisture will enter any openings.

NOTE: After the doors are reversed, reinstall the handles. If the doors are not shutting on their own, see the “Door Closing and Alignment” section.

TOP HINGE

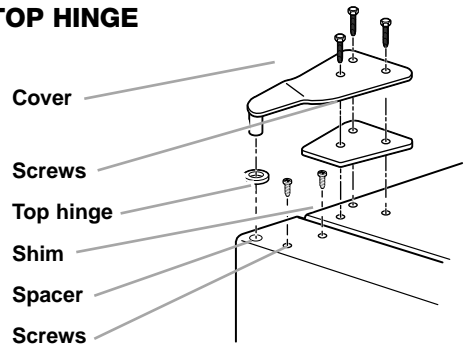

CENTER HINGE

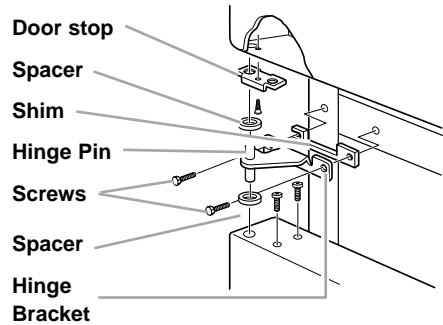

BOTTOM HINGE

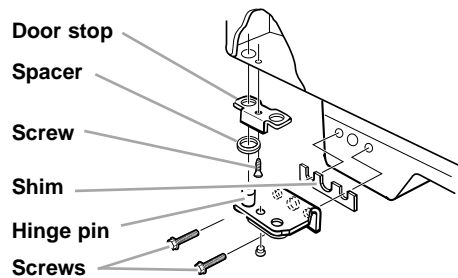

Reversing the door swing (cont.)

Reversing the handles

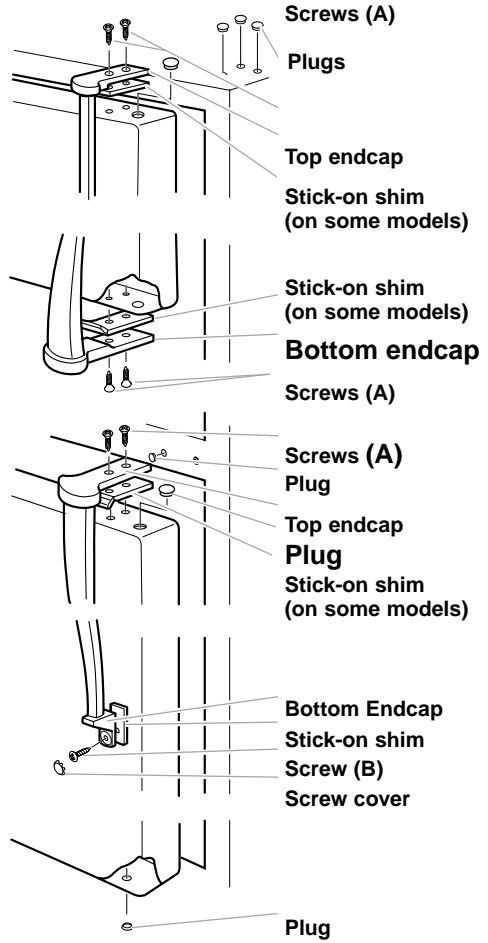
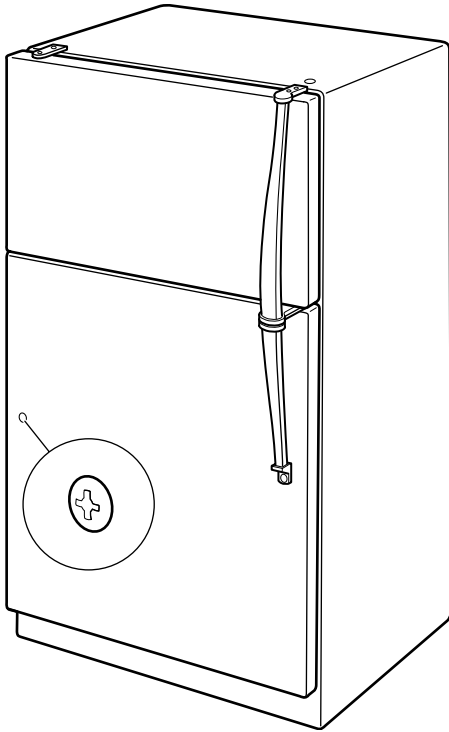

A

B



Handle Screws
 (Use on top and bottom of handle)

Handle Screw
 (Use on front of handles)

UNDERSTANDING THE SOUNDS YOU MAY HEAR

Your new refrigerator may make sounds that your old one didn't. Because the sounds are new to you, you might be concerned about them. Don't be. Most of the new sounds are normal. Hard surfaces like the floor, walls, and cabinets can make the sounds seem louder.

The following describes the kinds of sounds that might be new to you, and what may be making them.

Slight hum, soft hiss

You may hear the refrigerator's fan motor and moving air.

Clicking or snapping sounds

The thermostat makes a definite click when the refrigerator stops running. It also makes a sound when the refrigerator starts. The defrost timer will click when the defrost cycle starts.

Water sounds

When the refrigerator stops running, you may hear gurgling in the tubing for a few minutes after it stops. You may also hear defrost water running into the defrost water pan.

Running sounds

Your refrigerator has a high-efficiency compressor and motor. It will run longer than older designs. It may even seem to run most of the time.

SAVING ENERGY

There are ways that you can help your refrigerator run more efficiently.

- Check the door gaskets for a tight seal. Leveling the cabinet will ensure a proper seal.
- Clean the condenser coils regularly. A coil cleaning brush is available for purchase (Part number 4210463).
- Open the door as few times as possible.
- refrigerator so that cold air cannot flow freely. See the "Ensuring proper air circulation" section.
- Do not set your refrigerator and freezer at a colder setting than is needed. Keep the refrigerator control at the lowest number setting that keeps milk or juice as cold as you like and ice cream firm.
- Do not put your refrigerator next to a heat source, such as a range, water heater, furnace, radiator, or in direct sunlight.

CARING FOR YOUR REFRIGERATOR

Your refrigerator is built to give you many years of dependable service. However, there are a few things you can do to help extend its product life. This section tells you how to clean your refrigerator and what to do when going on vacation, moving, or during a power outage.

CLEANING YOUR REFRIGERATOR

Both the refrigerator and freezer sections defrost automatically. However, clean both sections about once a month to prevent odors from building up. Wipe up spills immediately.

To clean your refrigerator:

- Unplug refrigerator or disconnect power.
- Remove all removable parts from inside, such as shelves, crispers, etc.
- Use a clean sponge or soft cloth and a mild detergent in warm water. Do not use abrasive or harsh cleaners.
- Hand wash, rinse, and dry all surfaces thoroughly.
- Plug in refrigerator or reconnect power.

Additional cleaning tips are listed below:

! WARNING



Explosion Hazard

Use nonflammable cleaner.

Failure to do so can result in death, explosion, or fire.

PART	WHAT TO USE	HOW TO CLEAN
Removable parts (shelves, crisper, etc.)	Sponge or cloth with mild detergent and warm water	<ul style="list-style-type: none"> • Hand wash, rinse, and dry thoroughly.
Outside	Sponge, cloth, or paper towel with mild detergent, warm water, and an appliance wax (or good auto paste wax)	<ul style="list-style-type: none"> • Wash outside of cabinet. Do not use abrasive or harsh cleaners. • Wipe and dry thoroughly. • Wax painted metal surfaces at least twice a year. Apply wax with a clean, soft cloth. <p style="margin-left: 20px;">Waxing painted metal surfaces provides rust protection.</p> <p style="margin-left: 20px;">Do not wax plastic parts.</p>
Inside walls (allow freezer to warm up so cloth won't stick)	Sponge, soft cloth, or paper towel with baking soda or mild detergent and warm water	<ul style="list-style-type: none"> • Wash with mixture of warm water and <ul style="list-style-type: none"> – mild detergent, or – baking soda (26 g [2 tablespoons] to .95 L [1 quart] of water). • Wipe and dry thoroughly.

continued on next page

PART	WHAT TO USE	HOW TO CLEAN
Door liners and gaskets	Sponge, soft cloth, or paper towel with mild detergent and warm water	<ul style="list-style-type: none"> • Wash, wipe, and dry thoroughly. <p>DO NOT USE cleaning waxes, concentrated detergents, bleaches, or cleaners containing petroleum on plastic parts.</p>
Plastic parts (covers and panels)	Soft, clean sponge or soft, clean cloth with mild detergent and warm water	<ul style="list-style-type: none"> • Wash, wipe, and dry thoroughly. <p>DO NOT USE paper towels, window sprays, scouring cleansers, or flammable fluids. These can scratch or damage material.</p>
Defrost pan	Sponge or cloth with mild detergent and warm water	<ul style="list-style-type: none"> • Roll refrigerator out away from the wall. • Wash, rinse, and dry thoroughly. Do not remove the defrost pan to clean it. • Roll refrigerator back into place. Make sure to leave 2.5 cm (1 inch) between the cabinet back and the wall. • Check to see if the refrigerator is level.
Condenser coils	Vacuum cleaner with extended narrow attachment	<ul style="list-style-type: none"> • Roll refrigerator out away from the wall. • Vacuum coils when dusty or dirty. Coils may need to be cleaned as often as every other month. • Roll refrigerator back into place. Make sure to leave 2.5 cm (1 inch) between the cabinet back and the wall. • Check to see if the refrigerator is level.
Floor under refrigerator	Floor cleaners	<ul style="list-style-type: none"> • Roll refrigerator out away from the wall. • Clean floor. • Roll refrigerator back into place. • Check to see if the refrigerator is level.

HOLIDAY AND MOVING CARE

Holidays

If you choose to leave the refrigerator on while you're away, use these steps to prepare your refrigerator before you leave.

1. Use up any perishables and freeze other items.
2. If your refrigerator has an automatic ice maker:
 - Raise ice maker arm to OFF (up) position.
 - Shut off water supply to the ice maker.
3. Empty the ice bin.

If you choose to turn the refrigerator off before you leave, follow these steps to prepare your refrigerator.

1. Remove all food from the refrigerator.
2. If your refrigerator has an automatic ice maker:
 - Turn off the water supply to the ice maker at least one day ahead of time.
 - When the last load of ice drops, raise the ice maker arm to the OFF (up) position.
3. Turn the Temperature Control to OFF.
4. Clean refrigerator, wipe it, and dry well.
5. Tape rubber or wood blocks to the tops of both doors to prop them open far enough for air to get in. This stops odor and mold from building up.

Moving

When you are moving your refrigerator to a new home, follow these steps to prepare it for the move.

1. If your refrigerator has an automatic ice maker:
 - Turn off the water supply to the ice maker at least one day ahead of time.
 - Disconnect the water line from the back of the refrigerator.
 - When the last load of ice drops, raise the ice maker arm to the OFF (up) position.
2. Remove all food from the refrigerator and pack all frozen food in dry ice.
3. Turn the Temperature Control to OFF.
4. Unplug the refrigerator.
5. Empty water from the defrost pan.
6. Clean, wipe, and dry thoroughly.
7. Take out all removable parts, wrap them well, and tape them together so they don't shift and rattle during the move.
8. Depending on the model, raise the front of the refrigerator so it rolls easier OR screw in the leveling legs so they don't scrape the floor. See the "Door Closing and Alignment" section.
9. Tape the doors shut and the power cord to the refrigerator cabinet.

When you get to your new home, put every thing back and refer to "Installing Your Refrigerator" for preparation instructions. Also, if your refrigerator has an automatic ice maker, remember to reconnect the water supply to the refrigerator.

POWER INTERRUPTIONS

If the electricity in your house goes off, call the power company and ask how long it will be off.

1. If the power will be out for 24 hours or less, **keep both doors closed** to help foods stay cold and frozen.
2. If the power will be out for more than 24 hours:
 - (a) Remove all frozen food and store it in a frozen food locker.

OR

- (b) Place 32 grams of dry ice in freezer for every liter (2 lbs. for every cubic foot) of freezer space. This will keep the food frozen for two to four days. While handling dry ice, wear gloves to protect your hands from ice burns.

OR

- (c) If neither a food locker nor dry ice is available, use up or can perishable food at once.

NOTE: A full freezer stays cold longer than a partly filled one. A freezer full of meat stays cold longer than a freezer full of baked goods. If food contains ice crystals, it may be safely refrozen, although the quality and flavor may be affected. If the condition of the food is poor, or if you feel it is unsafe, dispose of it.

FOOD STORAGE GUIDE

STORING FRESH FOOD

Wrap or store food in the refrigerator in airtight and moisture-proof material unless otherwise noted. This prevents food odor and taste transfer throughout the refrigerator. For dated products, check code date to ensure freshness.

Butter or margarine

Keep opened butter in covered dish or closed compartment. When storing an extra supply, wrap in freezer packaging and freeze.

Cheese

Store in the original wrapping until you are ready to use it. Once opened, rewrap tightly in plastic wrap or aluminum foil.

Milk

Wipe milk cartons. For best storage, place milk on interior shelf.

Eggs

Store in original carton on interior shelf.

Fruit

Wash, let dry, and store in refrigerator in plastic bags or crisper. Do not wash or hull berries until they are ready to use. Sort and keep berries in original container in a crisper, or store in a loosely closed paper bag on a refrigerator shelf.

Leafy vegetables

Remove store wrapping and trim or tear off bruised and discolored areas. Wash in cold water and drain. Place in plastic bag or plastic container and store in crisper.

Vegetables with skins

(carrots, peppers)

Place in plastic bags, or plastic container and store in crisper

Fish

Use fresh fish and shellfish the same day as purchased.

Meat

Store most meat in original wrapping as long as it is airtight and moisture-proof. Rewrap if necessary. See the following for storage times. When storing meat longer than the times given, freeze the meat.

Chicken	1-2 days
Ground beef	1-2 days
Cold cuts	3-5 days
Steaks/roasts	3-5 days
Variety meats	1-2 days
Cured meats.....	7-10 days

Leftovers

Cover leftovers with plastic wrap or aluminum foil. Plastic containers with tight lids can also be used.

STORING FROZEN FOOD

The freezer section is designed for storing commercially frozen food and for freezing food at home.

NOTE: For further information about preparing food for freezing or food storage times, check a freezer guide or reliable cookbook.

Packaging

Successful freezing depends on the correct packaging. When you close and seal the package you must not allow air or moisture in or out. If you do, you could have food odor and taste transfer throughout the refrigerator, and also dry out frozen food.

Packaging recommendations:

- Rigid plastic containers with tight-fitting lids
- Straight-sided canning/freezing jars
- Heavy-duty aluminum foil
- Plastic-coated paper
- Non-permeable plastic wraps (made from saran film)
- Specified freezer self-sealing plastic bags

Follow package or container instructions for proper freezing methods.

Do not use:

- Bread wrappers
- Non-polyethylene plastic containers
- Containers without tight lids
- Wax paper or wax-coated freezer wrap
- Thin, semi-permeable wrap

Freezing

Your freezer will not quick-freeze any large quantity of food. Put no more unfrozen food into the freezer than will freeze within 24 hours (about 2 to 3 lbs of food per cubic foot [907-1,350 g per liter] of freezer space). Leave enough space in the freezer for air to circulate around packages. Also leave enough room at the front so the door can close tightly.

Storage times vary according to the quality and type of food, the type of packaging used (airtight and moisture-proof), and the storage temperature. Ice crystals inside a sealed package are normal. It means that moisture in the food and air inside the package have condensed, creating ice crystals.

IF YOU NEED ASSISTANCE OR SERVICE

Performance problems often result from little things you can fix without tools. Please read through the chart below before calling for service on your appliance.

I. BEFORE CALLING FOR ASSISTANCE...

Listed in this chart are the most common problems consumers run into with their appliances. Please read through this and see if it can solve your problem.

PROBLEM	CHECK THE FOLLOWING
Your refrigerator will not operate	Is the power supply cord firmly plugged into a live circuit with proper voltage? Has a household fuse or circuit breaker blown/tripped? Is the Temperature Control set to the OFF position?
The lights do not work	Is the power supply cord firmly plugged into a live circuit with proper voltage? Has a household fuse or circuit breaker blown/tripped? Is a bulb burned out?
You hear unfamiliar sounds or a rattling/jingling noise	Is something on top of or behind the refrigerator? Some new sounds are normal. See "Understanding the sounds you may hear" section.
There is water in the defrost pan	This is normal on hot, muggy days. Make sure the refrigerator is level so the pan does not overflow.
The motor seems to run too much	Are the condenser coils dirty? Has the door been open often? Has a large amount of food been added at one time? The motor naturally runs longer in these cases. Is the room hot? If the room is too warm, the motor runs longer to keep the unit cool.

2. IF THE PROBLEM IS NOT DUE TO ONE OF THE ITEMS LISTED IN STEP 1† ...

Contact the dealer from whom you purchased the unit or a Whirlpool designated service company.

† When asking for help or service: Please provide a detailed description of the problem, your appliance's complete model and serial numbers, and the purchase date. (See page 2.) This information will help us respond properly to your request.

3. IF YOU NEED REPLACEMENT PARTS† ...

Look for quality replacement parts whenever you need a replacement part for your Whirlpool appliance.

To locate replacement parts in your area, contact the dealer from whom you purchased the unit or a Whirlpool designated service company.

WHIRLPOOL*

Refrigerator Warranty

LENGTH OF WARRANTY	WHIRLPOOL WILL PAY FOR						
FULL ONE-YEAR WARRANTY From Date of Purchase	Factory Specified Parts and repair labor to correct defects in materials or workmanship. Service must be provided by a Whirlpool designated service company.						
FULL FIVE-YEAR WARRANTY From Date of Purchase	Factory Specified Parts and repair labor to correct defects in materials or workmanship in the sealed refrigeration system. These parts are: <table style="margin-left: 20px; border: none;"> <tr> <td>1. Compressor</td> <td>4. Drier</td> </tr> <tr> <td>2. Evaporator</td> <td>5. Connecting tubing</td> </tr> <tr> <td>3. Condenser</td> <td></td> </tr> </table> Service must be provided by a Whirlpool designated service company.	1. Compressor	4. Drier	2. Evaporator	5. Connecting tubing	3. Condenser	
1. Compressor	4. Drier						
2. Evaporator	5. Connecting tubing						
3. Condenser							
WHIRLPOOL WILL NOT PAY FOR							
<p>A. Service calls to:</p> <ol style="list-style-type: none"> 1. Correct the installation of your refrigerator. 2. Instruct you how to use your refrigerator. 3. Replace house fuses or correct house wiring or plumbing. 4. Replace light bulbs. <p>B. Repairs when your refrigerator is used in other than normal, single-family household use.</p> <p>C. Pickup and delivery. Your refrigerator is designed to be repaired in the home.</p> <p>D. Damage to your refrigerator caused by accident, misuse, fire, flood, acts of God, or use of products not approved by Whirlpool.</p> <p>E. Any food loss due to product failure.</p> <p>F. Repairs to parts or systems resulting from unauthorized modifications made to the appliance.</p>							

11/98

WHIRLPOOL CORPORATION SHALL NOT BE LIABLE FOR INCIDENTAL OR CONSEQUENTIAL DAMAGES.

Outside the United States, a different warranty may apply. For details, please contact your authorized Whirlpool dealer.

Free Manuals Download Website

<http://myh66.com>

<http://usermanuals.us>

<http://www.somanuals.com>

<http://www.4manuals.cc>

<http://www.manual-lib.com>

<http://www.404manual.com>

<http://www.luxmanual.com>

<http://aubethermostatmanual.com>

Golf course search by state

<http://golfingnear.com>

Email search by domain

<http://emailbydomain.com>

Auto manuals search

<http://auto.somanuals.com>

TV manuals search

<http://tv.somanuals.com>