

Installation

Instructions

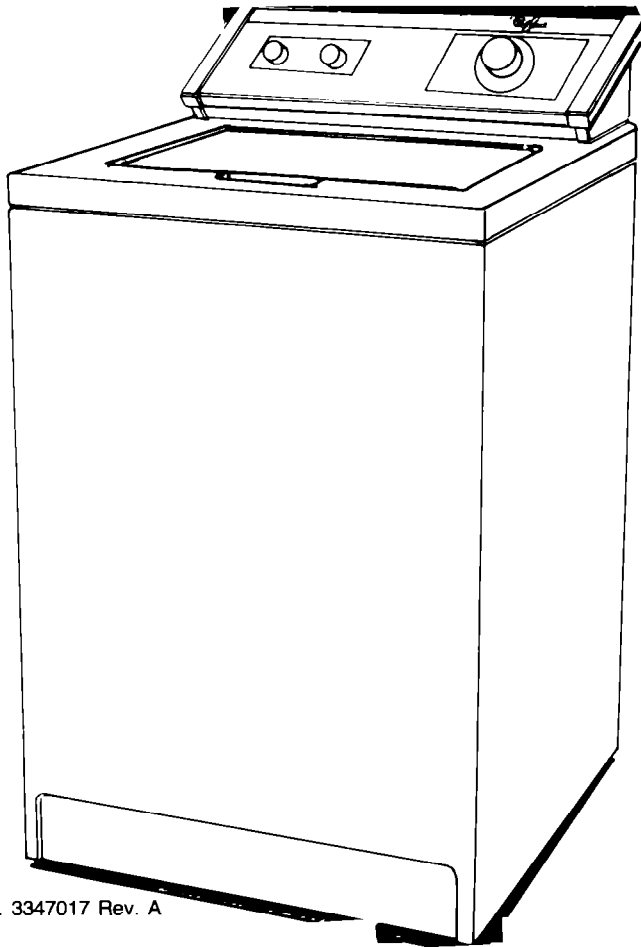

1-93

Part No. 3347017 Rev. A

Built-In Ovens and Surface Units, Ranges, Microwave Ovens, Compactors, Room Air Conditioners, Dehumidifiers, Automatic Washers, Clothes Dryers, Freezers, Refrigerator-Freezers, Ice Makers, Dishwashers, Built-In Ovens and Surface Units, Ranges, Microwave Ovens, Compactors, Room Air Conditioners, Dehumidifiers, A



Before you start...

Check location where washer will be installed. Proper installation is your responsibility. Make sure you have everything necessary for correct installation.

Grounded electrical outlet is required. See Electrical requirements.

Standpipe drain system: needs a two-inch minimum diameter standpipe with minimum carry-away capacity of 17 gallons (64 liters) per minute. Top of standpipe must be at least 34 inches (86 centimeters) high and no higher than 52 inches (132 centimeters) from bottom of washer.

Floor drain system: requires a siphon break, Part No. 285320

Untape and open washer lid. Remove packages, hoses, and literature rack from washer.

Hot and cold water faucets: must be within 4 feet (122 centimeters) of the back of the washer and provide water pressure 5-100 PSI (34.5-689.6 kPa).

Laundry tub drain system: needs a 20-gallon (75 liter) laundry tub. Top of tub must be at least 34 inches (86 centimeters) high and no higher than 52 inches (132 centimeters) from bottom of washer.

If a longer drain hose is needed, Part No. 388423 and the hose extension kit, Part No. 285442, are available from Whirlpool authorized parts distributors.

Important: observe all governing codes and ordinances.

Water heater: set to deliver 140°F (60°C) water to the washer.

Protection from weather: do not store or operate washer below 32°F (0°C). See Use and Care Guide for further information.

Level floor: maximum slope under washer 1 inch (25 millimeters).

Support: floor must be sturdy enough to support washer weight 315 pounds (143kg).

Tools needed for installation.

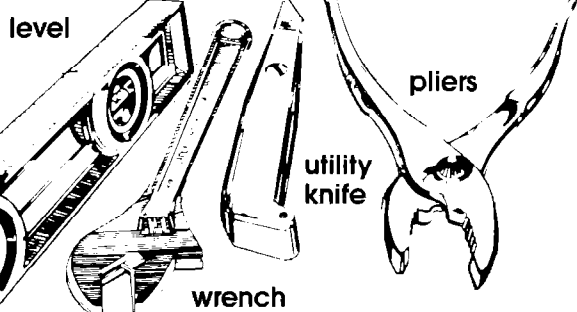

Parts supplied for installation.

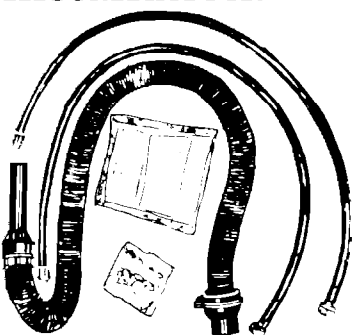

Remove parts from packages. Check that all parts were included.

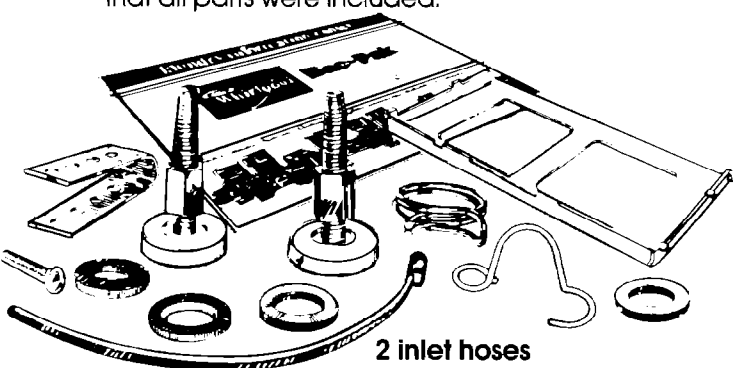

literature package
1 drain hose
1 plastic strap
1 hose clamp
1 grounding clamp and screw

2 inlet hoses
4 flat water hose washers
1 literature rack (not supplied with all models)
2 front leveling legs with nuts
1 wire form

Electrical requirements

Prefix "3" Models.
240 Volts, 5.0 Amps.
50 Hz., 8 Amp. fuse.

Electrical ground is required on this appliance.

A fused electrical supply is required. (Time-delay fuse or circuit breaker is recommended.) It is recommended that a separate circuit serving only this appliance be provided.

WARNING: AN EXTENSION CORD SHOULD NOT BE USED WITH THIS APPLIANCE. SUCH USE MAY RESULT IN A FIRE, ELECTRICAL SHOCK, OR OTHER PERSONAL INJURY.

Recommended grounding method

DANGER: Improper connection of the equipment grounding line conductor can result in a risk of electrical shock.

Do Not, under any circumstances, remove the power supply cord grounding prong.

For your personal safety, this appliance must be grounded. This appliance is equipped with a power supply cord having a grounding plug.

To minimize possible shock hazard, the cord must be plugged into a mating grounding type wall receptacle, grounded in accordance with local codes and ordinances. If a mating wall receptacle is not available, it is the personal responsibility and obligation of the customer to have a properly grounded wall receptacle installed by a qualified electrician. See Figures 1-3 to determine the proper mating wall receptacle for the power supply cord plug equipped with this washer.

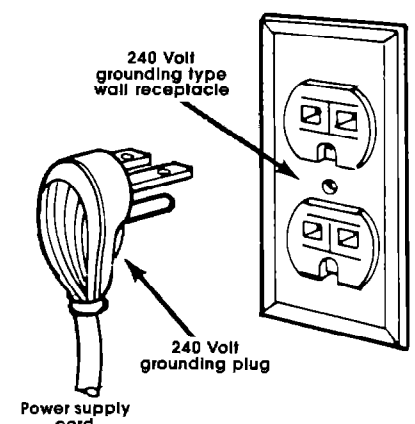

Figure 1

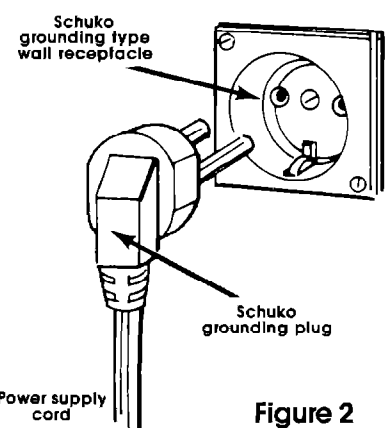

Figure 2

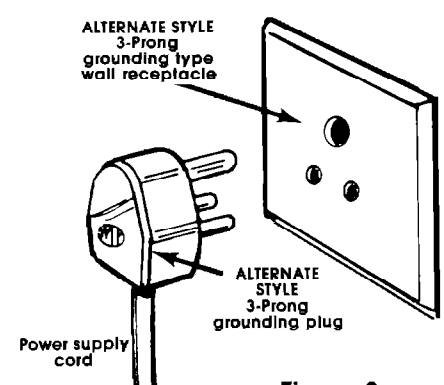
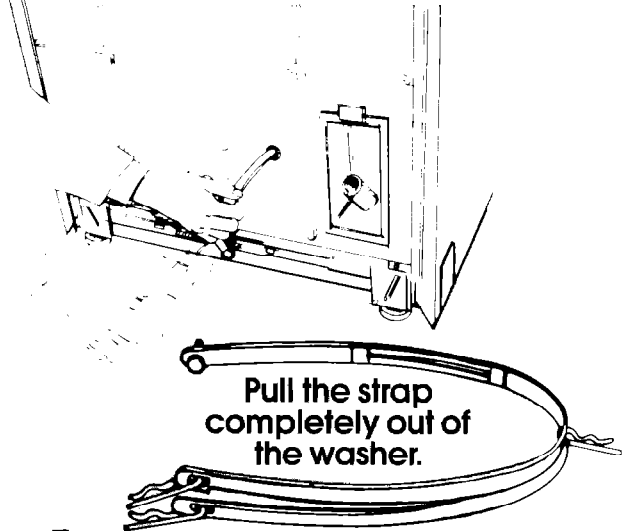

Figure 3

Now Start...

With Washer in Laundry Area.



Pull the strap completely out of the washer.

1. Remove tape that covers shipping strap. Pull to completely remove the shipping strap from the inside of the washer. Read, then remove label that covers power cord and drain connector. Peel the tape down and off each side of cabinet.

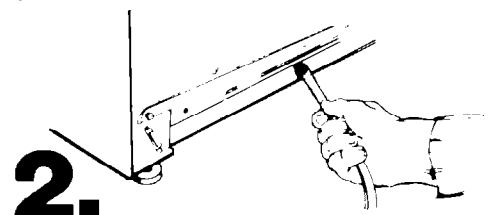

2. Pull firmly to remove the other end of the shipping strap from the back of the washer. The shipping strap plug must be completely removed from the washer for the self-leveling legs to be released.

Use new hoses and washers that came with your Whirlpool washer.

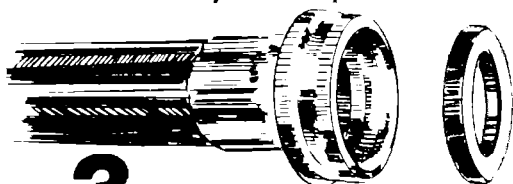

3. coupling washer
Insert a flat washer into each end of the inlet hoses. Check that washers are firmly seated in couplings.

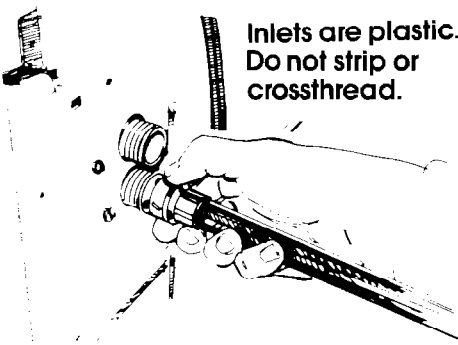

Inlets are plastic. Do not strip or crossthread.

4. Attach hose to bottom inlet valve opening first; then second hose to top inlet. Tighten couplings by hand. Then use pliers to make an additional two-thirds turn.

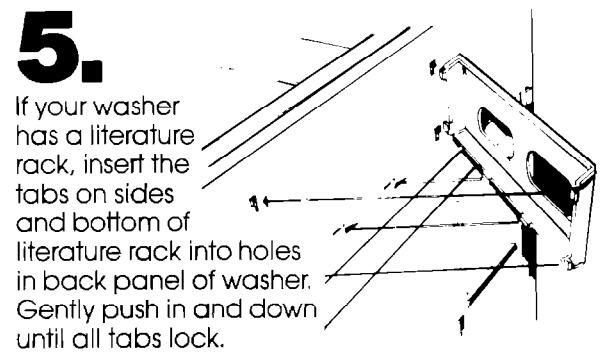

5. If your washer has a literature rack, insert the tabs on sides and bottom of literature rack into holes in back panel of washer. Gently push in and down until all tabs lock.

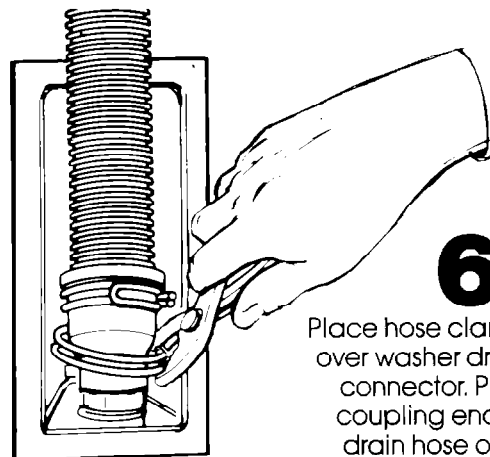

6. Place hose clamp over washer drain connector. Push coupling end of drain hose onto washer connector. Use pliers to open clamp and slide clamp over drain hose. Check for good fit.

Numbers correspond to steps.

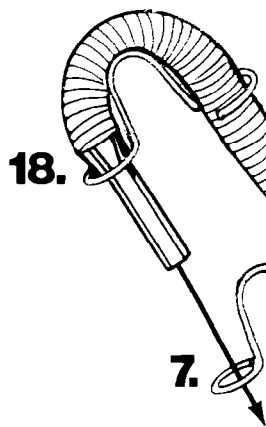
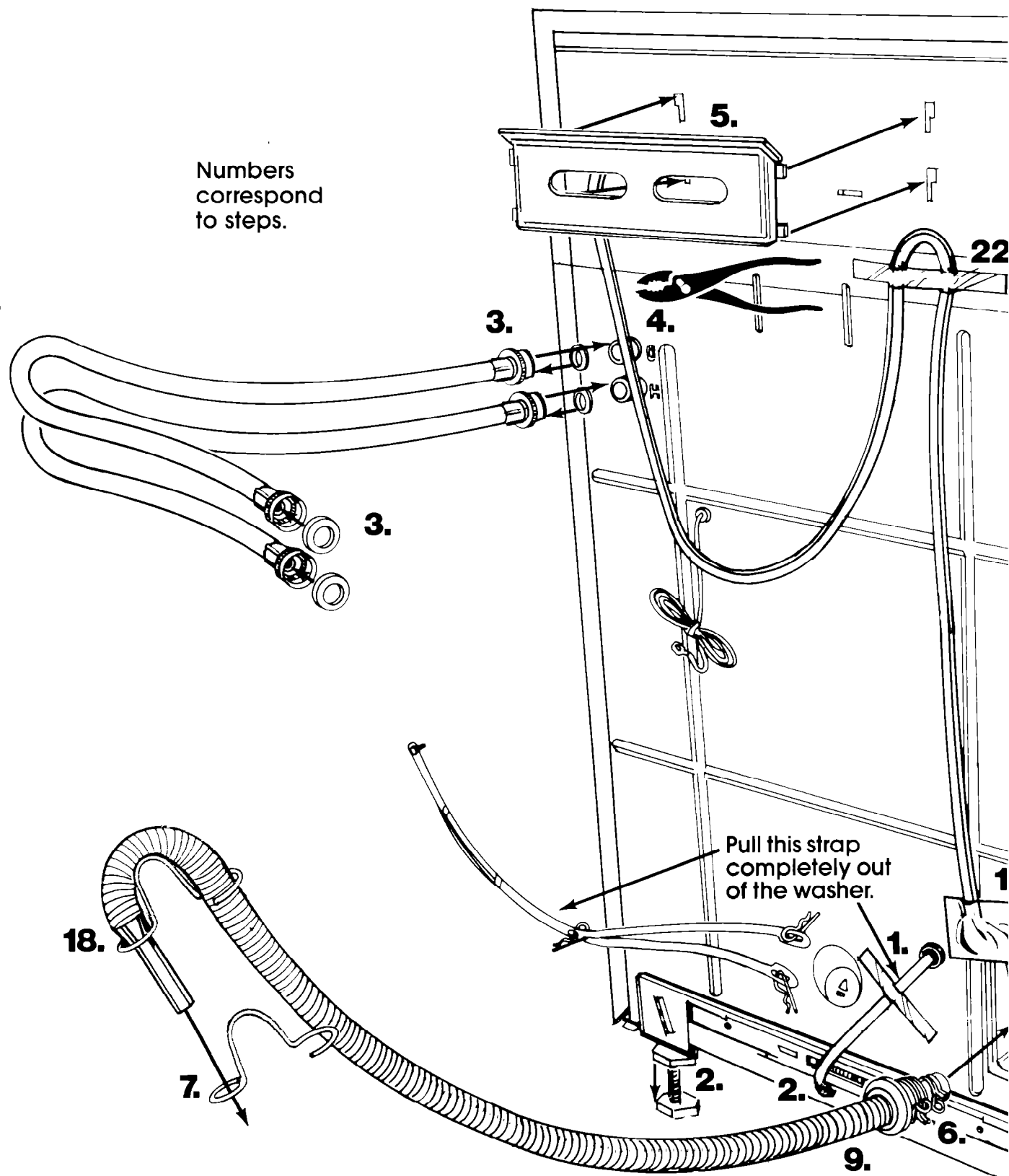

7. Slide nozzle end of drain hose through the small "loop" in the wire form. Wrap the hook end of the wire form around the drain hose to form a "hook shape."

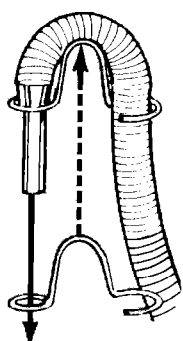

8. Move washer close to final position. Put "hook" end of drain hose into laundry tub or standpipe. Check for proper length of drain hose.

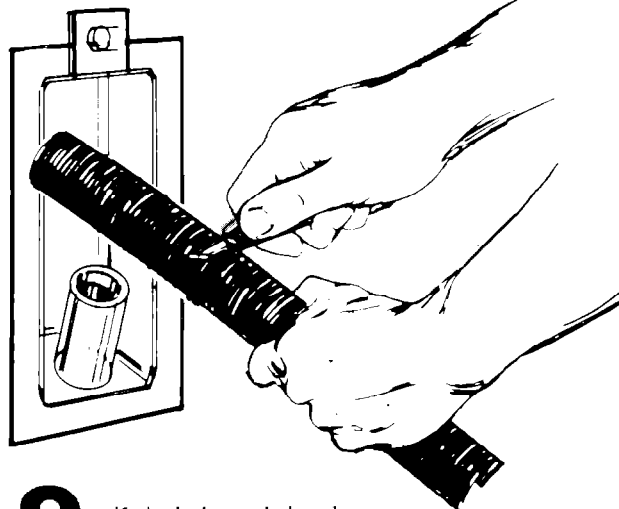

9. If drain hose is too long - disconnect. Remove clamp and coupling. Estimate length of drain hose needed. Cut flexible end of hose. (Do not cut hook-shaped end of drain hose.) Push and twist coupling securely onto drain hose. (You should feel top of hose through coupling.) Slide clamp

over coupling and hose. Reinstall drain hose. See step 6.

DO NOT FORCE EXCESS LENGTH OF DRAIN HOSE DOWN THE STANDPIPE. THIS COULD CAUSE SIPHONING.



10. Before attaching water inlet hoses, run water through both faucets to get rid of particles in water lines.

11. Attach bottom hose (inlet marked "H") to hot water faucet. Attach top hose (inlet marked "C") to cold water faucet. Tighten coupling to faucet by hand, then use pliers to make final two-thirds turn.

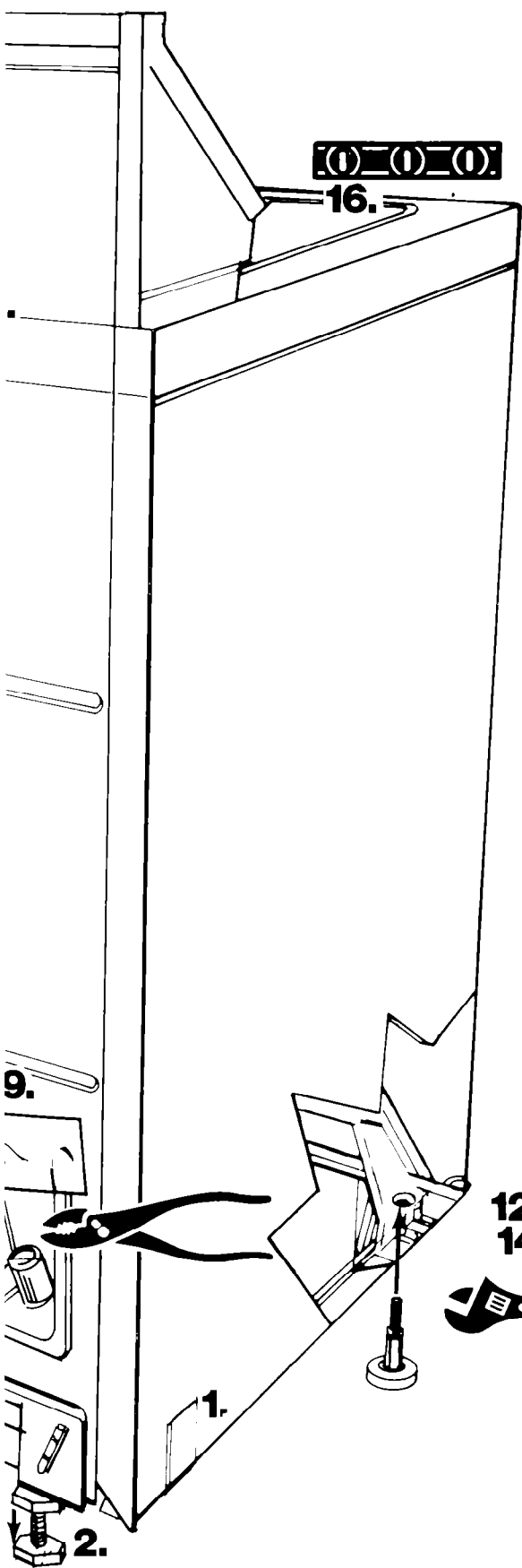

14.

Insert legs into correct holes at each front corner of washer until nuts touch washer. **Do not** tighten nuts until step 17.

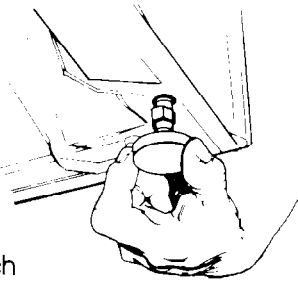

15.

Tilt washer backward and remove corner post(s). Gently lower washer to floor.

Move washer to its permanent location.

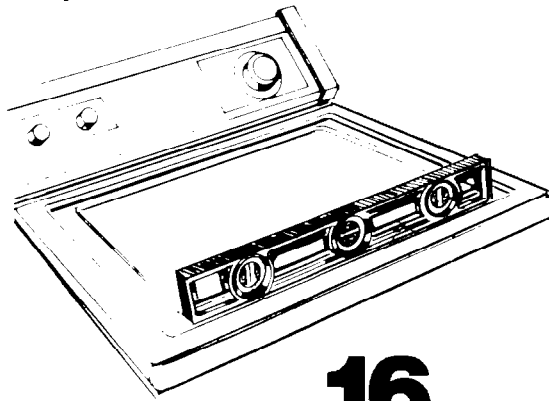

16.

Tilt washer forward raising back legs 1" (25 mm) off of floor to adjust rear self-leveling legs. Gently lower washer to floor. Check levelness at the washer front and from front to back on each side using a carpenter's level.

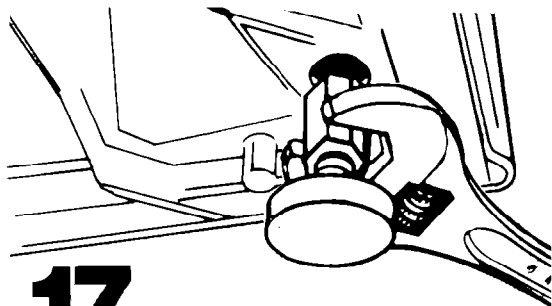

17.

If washer is not level, screw the front legs up or down to adjust. Make final check with level.

When washer is level, use wrench to turn nuts on front legs up tightly against washer base. If nuts are not tight against washer base, the washer may vibrate.

18.

Put "hook" end of drain hose in tub or standpipe. Secure drain hose by wrapping the plastic strap around the hose as shown in Figures A-C. If drain hose cannot be strapped in place, it must be cut exactly to length so the "hook" end is held tightly over the edge of tub or standpipe as shown in Figure D.

Note: If washer is moved to adjust drain hose, the washer must be leveled again. Repeat steps 15-17.

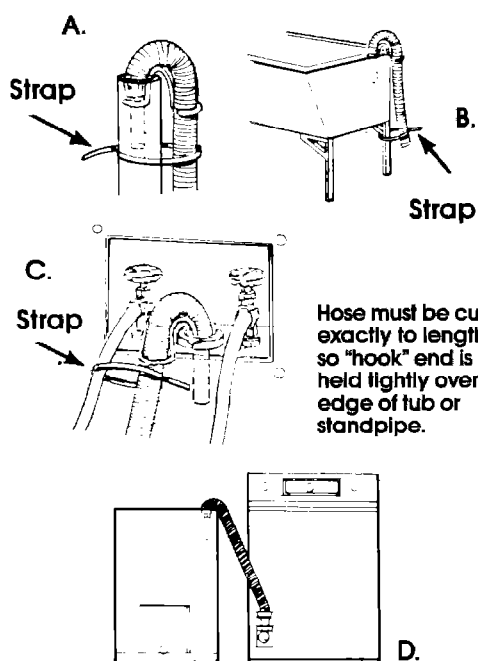

CHECK THAT HOSE IS NOT TWISTED OR KINKED AND IS SECURELY IN PLACE.

19. CHECK ELECTRICAL REQUIREMENTS. BE SURE YOU HAVE CORRECT ELECTRICAL SUPPLY AND RECOMMENDED GROUNDING METHOD.

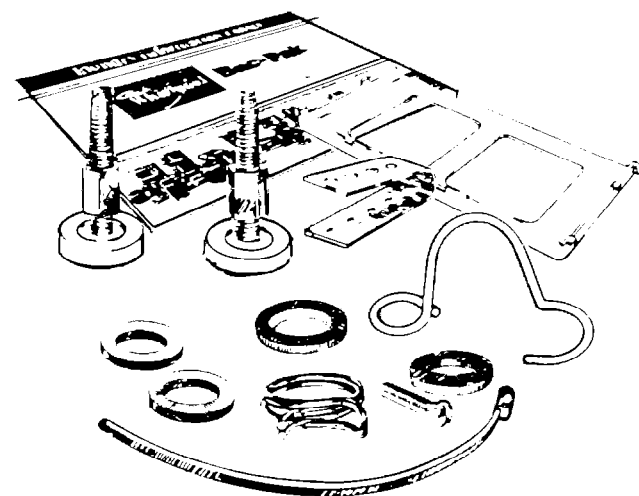

20. Check that all parts are now installed. See parts list, Panel A. If there is an extra part, go back through steps to see which step was skipped.

21. Turn on water faucets and check for leaks. Tighten couplings if there is leaking.

22. Untape electrical cord and plug into grounded outlet.

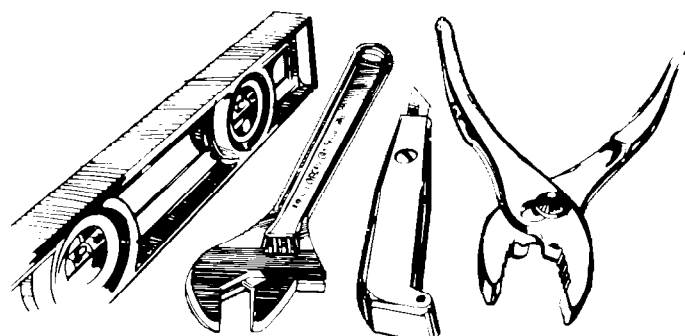

23. Check that you have all tools that you started with and that the shipping strap with its 3 cotterpins and plug was removed from the washer.

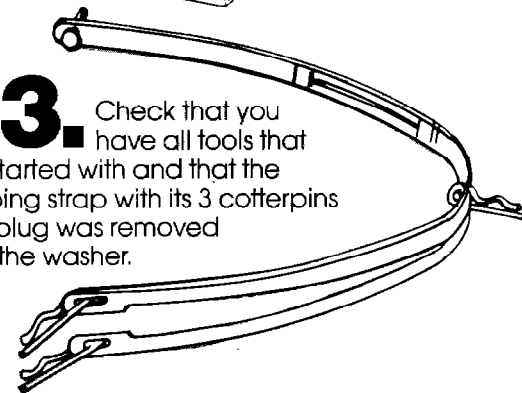

24. Take a few minutes and read the Use and Care Guide to fully understand your new washer. Now start the washer and allow it to complete the regular cycle. Put the literature in the Literature Rack. (Literature Rack not supplied with all models.)

Use caution when moving this appliance to prevent damage to floor coverings. Before moving, slide washer onto cardboard or hardboard to prevent damage.

12. Carefully tilt washer backward until front of washer is 3-4 inches off of floor. Insert 1 or 2 corner posts.

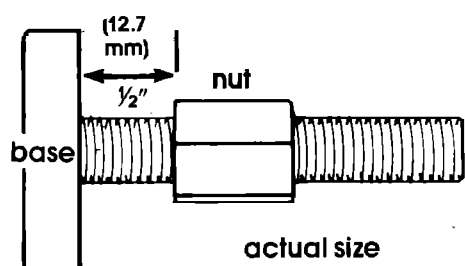

13. Use legs and nuts from parts package. Screw nut down to within 1/2" of base.

You have successfully installed your new Whirlpool washer. To get the most efficient use from your washer, read your Whirlpool Use and Care Guide. **Congratulations!**

Keep Installation Instructions and Guide. The instructions will make re-installing your Whirlpool washer in another home as easy as the first installation.



Part No. 3347017 Rev. A

Prepared by Whirlpool Corporation, Benton Harbor, Michigan 49022

Printed in U.S.A.

Free Manuals Download Website

<http://myh66.com>

<http://usermanuals.us>

<http://www.somanuals.com>

<http://www.4manuals.cc>

<http://www.manual-lib.com>

<http://www.404manual.com>

<http://www.luxmanual.com>

<http://aubethermostatmanual.com>

Golf course search by state

<http://golfingnear.com>

Email search by domain

<http://emailbydomain.com>

Auto manuals search

<http://auto.somanuals.com>

TV manuals search

<http://tv.somanuals.com>