

WhisperKOOOL[®] XLT Owner's Manual



Protecting Your Investment In Fine Wines



Copyright ©1998-2004 Vinothèque Wine Cellars All rights reserved.

This manual, the product design, and the design concepts are copyrighted by Vinothèque Wine Cellars, with all rights reserved. Your rights with regard to the hardware and manual are subject to the restrictions and limitations imposed by the copyright laws of the United States of America. Under copyright laws, this manual may not be copied, reproduced, translated, transmitted, or reduced to any printed or electronic medium or to any machine-readable form, for any purpose, in whole or in part, without the written consent of Vinothèque Wine Cellars.

Every effort has been made to ensure that the information in this manual is accurate. Vinothèque Wine Cellars is not responsible for printing or clerical errors.

Vinothèque Wine Cellars reserves the right to make corrections or improvements to the information provided and to the related hardware at any time, without notice.

Vinothèque, and WhisperKOOL are registered trademarks, and ECE is a trademark of Vinothèque Wine Cellars. All rights reserved.

Mention of third-party products is for informational purposes only and constitutes neither an endorsement nor a recommendation. Vinothèque Wine Cellars assumes no liability with regard to the performance or use of these products.

Rev. 17-1103

TABLE OF CONTENTS

Introduction 2

 What Is the WhisperKOOL® System? 2

 How Does the WhisperKOOL System Work? 2

Receiving and Unpacking 3

Quick Start Guide 4

Preparing the Wine Cellar 5

 Mounting the Unit 6

 Ventilation 7

 Cutting the hole for the WhisperKOOL unit 8

Installation 10

 Electrical Needs 11

 Sizing Unit to Room 11

 Placement of Unit 13

 Installing Thermostat 13

Using the WhisperKOOL System 13

 Condensate Evaporator Switch 13



 Drain Line 13

Liquid Measuring Thermostat System 14

PDT JR. Operating Instructions 15

PDT Operating Instructions 16

Normal Operation 17

 Maintenance 17

 Humidity Control 17

Troubleshooting Guide 18

 Solutions to Common Problems 18

Troubleshooting Checklist 23

Temperature Differential Testing 25

Technical Assistance 28

 How to Contact Customer Service 28

Warranty Clarification 29

Limited Warranty 31

NEW OWNERS PLEASE NOTE...

ALWAYS PLACE UNIT IN UPRIGHT POSITION

Do not start or plug-in your new unit for 24 hours after delivery. . .

Units are sometimes accidentally tipped onto their sides during shipping which may allow compressor oil to escape their reservoirs. . .

Premature starting—before the oil has had a chance to resettle—can cause damage to the compressor and result in a lack of cooling.

A DEDICATED 20 AMP CIRCUIT IS HIGHLY RECOMMENDED FOR OPTIMUM OPERATION!

INTRODUCTION

Thank you for purchasing the WhisperKOOL® wine cellar temperature and humidity maintenance system.

Please take the time to read through the owner's manual so you understand the correct operations of the WhisperKOOL unit.

What Is the WhisperKOOL System?

The WhisperKOOL system is a specialized piece of equipment designed to absorb heat from a cellar and discharge it through the rear of the unit into an adjacent room. **The unit will operate 75 to 80 percent of the time in order to maintain an ideal temperature and humidity in a wine cellar.** Essentially, it will operate as needed to absorb the heat that naturally permeates the cellar. It is important to follow the cellar construction guides provided within in order to maximize effectiveness based on the quality of efficiency in the vapor barrier, therefore reduce the operating time of the cooling unit itself.

How Does the WhisperKOOL System Work?

- **The WhisperKOOL system** is designed to maintain humidity, while measuring and maintaining the wine temperature in the cellar. This is achieved by gently cooling rather than by quick-chilling.
- **Temperature Setting:** The WhisperKOOL unit can be set at any temperature within the acceptable wine-aging range of 50°F -to- 70°F. It is designed to cool 30°F cooler than the ambient temperature of the space it is exhausting to.
- **Humidity Control:** There are no separate controls for maintaining proper humidity. Humidity is managed through the design and engineering of the unit. As the temperature begins to drop within the wine cellar, the relative humidity will rise, while the absolute humidity will stay the same. For more information about this process, see Normal Operation on page 17.

All units come with a drain line for additional removal of excess condensate, as a back up system to the Condensate Evaporator which is used to maintain proper humidity. If the unit is installed in a high humidity area of the country, it is mandatory to install the drain line attachment for the unit to function effectively, preventing overflows and leaks from build up of condensate. ***Failure to install the drain line voids warranty.***

- **The WhisperKOOL system** is designed to be mounted through an interior wall into the cellar. The unit will operate correctly in a controlled environment to properly manage the effective cooling of the cellar. The unit is not designed to withstand the elements of an outdoor climate where summer temperatures exceed 85 degrees or in winter environments where temperatures reach freezing. The components are not designed for these extreme conditions and premature failure may occur.

Note: Improperly preparing your enclosure or incorrectly installing your WhisperKOOL system may cause unit failure, leaking of condensation, and other negative side effects. Protective housings can be purchased to prevent premature failure in cases where the unit is installed through an exterior wall.

RECEIVING AND UNPACKING

Please examine the WhisperKOOL packaging for any damage to the carton. Note any damage on the bill of lading, shipper's receipt, or airbill. Damaged merchandise should be accepted. Contact Vinothèque Customer Service immediately.

Do not attempt to install any unit with cosmetic damage. This includes (but is not limited to) bent flange and/or brackets. A representative will file a claim with the shipping company, arrange for a replacement unit to be shipped to you and for the original unit to be picked up. In some instances, an inspection must take place at the point of receipt, in which case you will be contacted by the shipping company to schedule an appointment to inspect the damaged goods.

Please leave the WhisperKOOL System in its original box until you are ready for installation. This will allow you to move the product safely without damaging it. When you are ready to remove the product from the box, see Installation on page 10.

Note: ***Save your box and all packing materials. They provide the only safe means of transporting the unit.***

Contents:

- Owner's Manual
- By-Pass Plug
- Registration/Warranty Card
- Insulation Foam (4 strips)
- 8 - 1 3/4" Screws (18 for WK 6000 & 8000)
- Power Cord
- Drain Line
- Thermostat

QUICK START GUIDE

This guide is meant to serve as a quick reference for installation of the WhisperKOOL unit. The remainder of this Owner's Manual will provide more detailed information and instructions.

Upon receiving the WhisperKOOL unit:

1. **Inspect the unit before installation.** If damage is found, please contact your distributor or Vinothèque Customer Service at 1.800.343.9463 ext 799.
2. The unit should **remain in an upright position for 24 hours** prior to operation.
3. The unit is designed to gently cool down the temperature of the cellar over time by cycling cooler and cooler air throughout. **Test the unit prior to installation.** With power off, attach the "by-pass plug" (included in accessory bag) to the open plug located on the unit, where the PDT thermostat will need to be installed. Operate unit for twenty minutes. While the unit is running and working properly, **the air discharged from the front should be 10 - 15°F cooler than the air** in the room. This means that in an environment where the air is 80°F, the unit will discharge air that is 68°F.
4. The WhisperKOOL unit **requires a dedicated 110-volt 20-amp circuit** (or 220-volt depending on the unit). Use a surge protector with the WhisperKOOL unit. **Do not use a GFI** (Ground Fault Interrupter) line.
5. For your convenience, the Whisperkool unit has two power sockets, one on the side of the unit and the other on the back. Both sockets come covered. **Remove the cover from *only* the desired power socket** in order to plug the unit in.
6. After testing, remove the "by-pass plug," mount unit to desired location, and install the PDT thermostat into the plug. **There is a five (5) minute delay on initial start up of the unit.**
7. **In areas of high humidity, put the condensate evaporator switch to the "ON" position.** It is also necessary to **install the drain line** to remove excess condensation from the unit.
8. The WhisperKOOL unit is intended **for use in properly designed and constructed wine cellars.** Hire a professional wine storage consultant with a valid contractor's license to build your wine cellar. Refer to the "How to Build a Wine Cellar" video available on the Vinothèque website at www.vinotheque.com.

Install the foam strips along the inside edge of the unit's flange to assure a proper seal against the wall.

Never try to open the WhisperKool unit, repair it yourself, or use a service company without Vinothèque's authorization. This will void your warranty.

If you encounter a problem with your WhisperKool unit, please refer to the Troubleshooting Checklist on pages 23-26. If you have any further questions, concerns, or need assistance, please contact Vinothèque Customer Service at 1.800.343.9463 ext. 799. Please be sure all testing has been completed prior to contacting Customer Service. Please have your results ready for your representative.

PREPARING THE WINE CELLAR

The performance and life of your WhisperKOOL System are contingent upon the steps you take in preparing the wine cellar.

It is highly recommended that you obtain the assistance of a wine storage professional.

Wine storage professionals work with licensed contractors, refrigeration technicians, and racking companies to build well-insulated, beautiful, and protective wine cellars. In some areas of the country, these professionals are not available. We have put together some useful tips to assist in the installation process.

Our recommendations are meant to act as a guide in the process of building a proper enclosure. Your intended location may have specific needs that we do not address.

Wall & Ceiling Framing

Build wine cellar walls using standard 2x4 or 2x6 construction methods and ceiling joists following the guidelines of local and state codes in your area. The general rule for a cellar is the thicker the walls, the higher the insulation factor, the better the cellar remains at a consistent temperature.

Insulation

Insulation is REQUIRED with the use of the WhisperKOOL product; Standard “Fiberglass” or “Rigid Foam” insulation is normally used in cellar construction, or in some cases, “blown in” insulation is used. It is very important that all walls and ceiling be insulated to keep the cellar temperature as consistent as possible during the summer and winter months. The R factor or thickness of insulation is determined by the thickness of the walls and ceiling. For example, fiberglass insulation of R13 is designed to be used in a 2x4 wall. R19 is used in a 2x6 wall. It is important to use the correct insulation for the wall thickness.

Vapor Barrier

Vapor barrier is REQUIRED if a climate control cooling unit is installed to keep the cellar at the correct temperature and humidity. 6mm plastic sheeting is applied to the warm side of the cellar walls. The vapor barrier must be either applied to the outside walls and ceiling, or if it is impossible to get to the outside, then the plastic must be applied from within the cellar. The most common method is to wrap the entire interior, leaving the plastic loose in the stud cavity so the insulation can be placed between each stud. All walls and ceiling must be wrapped in plastic for a complete vapor barrier.

In areas of humidity, such as the southern and gulf states, the vapor barrier will prevent infiltration of warm moist air. The moist air can cause mold to form. The cooling unit will strip excessive moisture from the air and create water, which will need to be dissipated back out of the cellar using the Condensate Evaporator system or drain line. In dry climates, the vapor barrier will provide more control over retaining the higher correct humidity within the cellar.

Ducting

The unit is designed to exhaust into an open area. In situations where ducting may be necessary, Vinothèque Wine Cellars provides a specially designed ducting accessory kit for the XLT unit. Please contact Customer Service to order the ducting accessory kit by phone (800) 343-9463. Using any other ducting system voids warranty. Sheet rock must be applied in the exhaust room with no vapor barrier or insulation exposed. Failure to complete the wine cellar voids the warranty.

Unobstructed Airflow

Unobstructed airflow to and from the unit is a critical factor in the unit's overall performance. Make sure there is a three-foot horizontal clearance in the front of the unit. This will assure that the unit can move the air around in an efficient manner. Avoid the attempt to camouflage the unit by installing racking in front of the unit. This will restrict airflow and thus the unit's ability to work efficiently.

Mounting the Unit

The unit should be mounted within 18 inches of the top of the room in order to achieve sufficient cooling. As the room cools down, the warm air will rise to the ceiling. Mounting the WhisperKOOL high in the room will create a consistently cool environment by capturing the warm air and replacing it with cool air. Mounting the unit low in the room will result in a temperature variation in the room due to the unit's inability to draw warm air from the ceiling of the cellar to the unit itself.

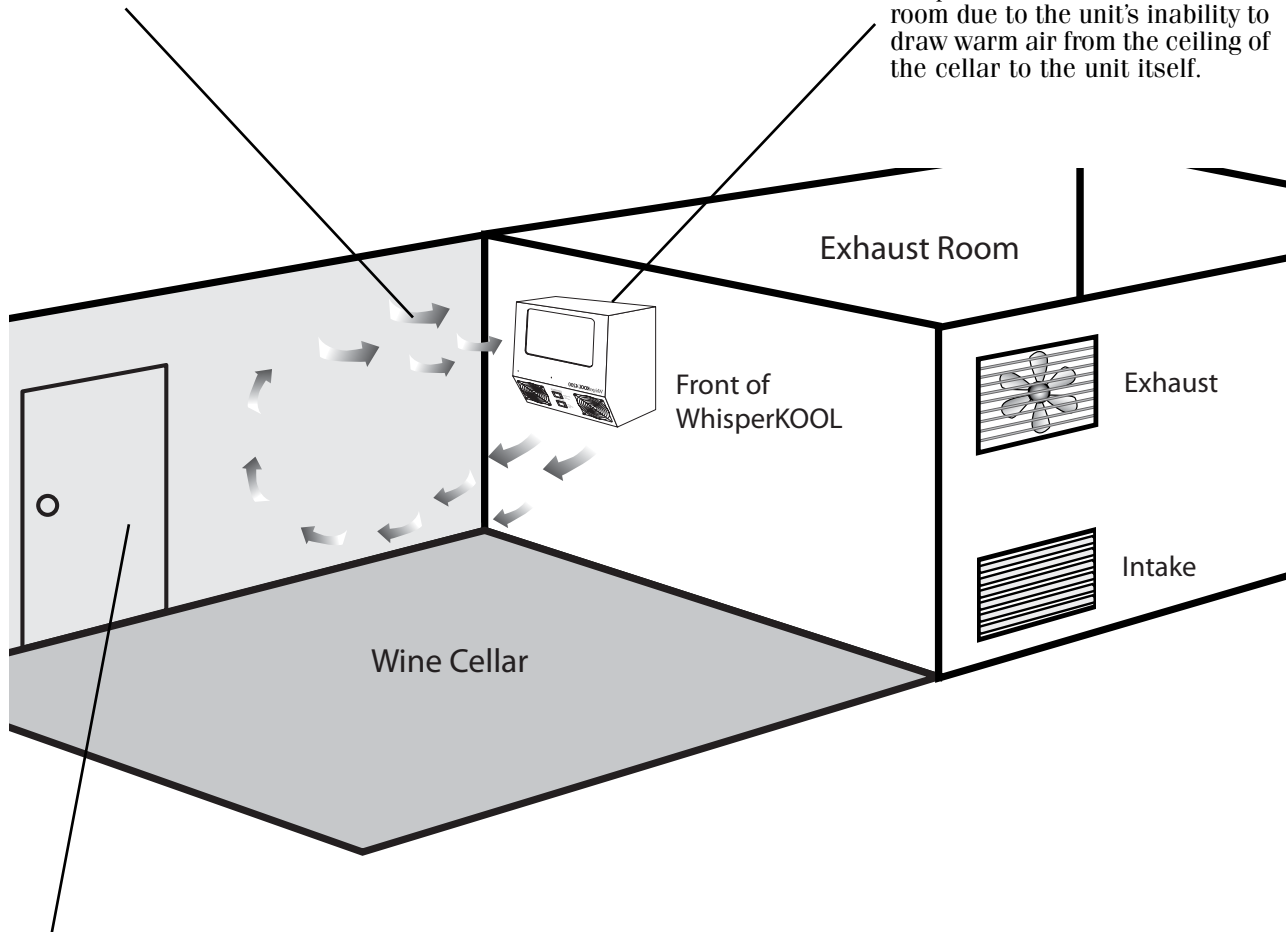

Door

An exterior grade (1 3/4") door must be installed as a cellar door. It is very important that weather stripping is attached to all 4 sides of the doorjam. A bottom "sweep" or threshold is also required. The door must have a very good seal to keep the cool cellar air from escaping out of the cellar. One of the most common problems with cooling units running continually is due to the door not sealing properly. In cases where glass doors are used and the room size is close to the recommended unit size, the next larger size WhisperKOOL should be used. This will compensate for the insulation loss due to the inefficient door.

Ventilation

The necessity of dissipating heat away from the unit is critical to the unit's performance and cannot be overstated. As the unit operates and cools, a greater amount of heat is generated on the exhaust side of the unit. Adequate ventilation is required in order to dissipate heat away from the unit. If ventilation is inadequate, the exhaust will heat up and adversely affect the unit's ability to cool. In some cases, it may be advisable to install a vent fan to dissipate heat within the exhaust area on the backside of the unit. However, you must have a fresh air inlet as well. If your unit requires ducting, please contact Vinothèque Wine Cellars Customer Service to obtain a specially designed ducting accessory kit for the XLT unit. Using any other ducting system voids warranty.

Ambient Temperature Factor

The cooling system has the ability to cool a maximum of 30°F below the ambient temperature in the room it is exhausting to. Therefore you want to exhaust the unit in a room which will not exceed 85°F. Otherwise the unit will not have the capacity to keep the wine at a desirable 55°F.

Unobstructed Airflow

Unobstructed airflow to and from the unit is a critical factor in the unit's overall performance. Make sure there is a minimum three-foot horizontal clearance from the rear of the unit as well as a minimum three foot clearance in front of the evaporator fans. This will assure that the unit can move the air around in an efficient manner.

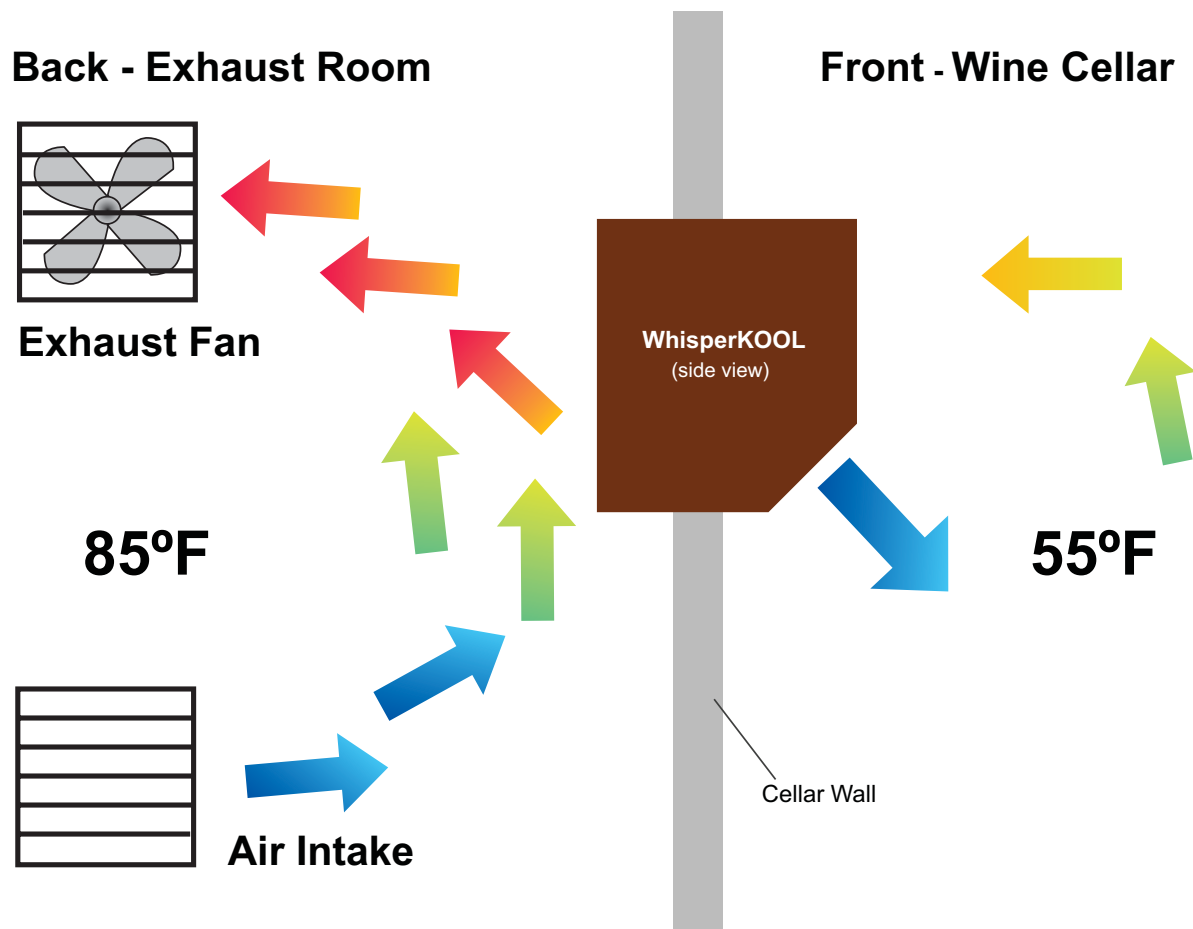

Tools Needed

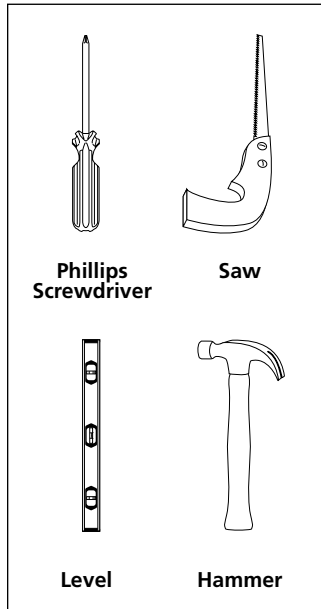

Cutting the hole for the WhisperKOOL unit

Locate the center of the room. Using a stud finder, locate two adjacent studs in the walls, and mark them with vertical lines.

Using a level and a pencil, mark a horizontal line on the wall between the two studs, approximately 1.25 inches (or as close as possible if more than 1.25") from the ceiling. Using a ruler or measuring tape, measure 16 inches down (22.75" for the 6000 and 8000 models), and mark another horizontal line parallel to the first one.

Mark the horizontal lines with a level.

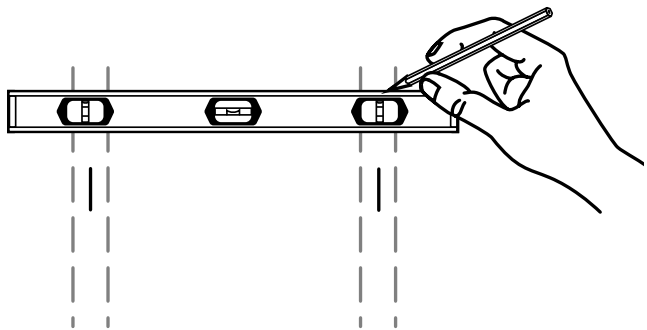

Using a saw, cut along the uppermost horizontal line until your saw reaches the stud. Turn the saw around, inserting it into the cut you have just made, and cut toward the opposite stud so that you have a clean horizontal cut between the two studs. Be careful not to cut into the studs themselves. Now make the second horizontal cut from stud to stud on the line 16 inches below the first cut (22.75" for the 6000 and 8000 models).

Cut horizontal lines from stud to stud.

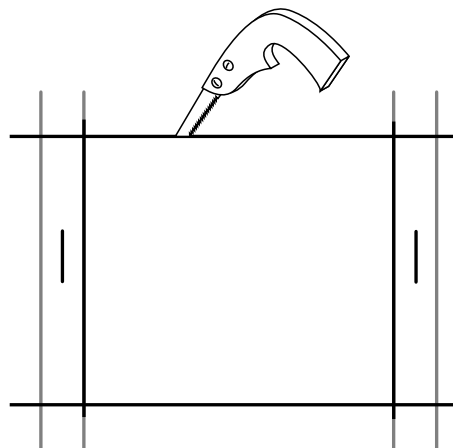

Once the horizontal lines have been cut, make vertical cuts using the inside edge of the studs as a guide. Once you have made both vertical cuts, you should have a rectangular hole in the sheetrock. Now you have to make the same hole on the other side of the wall. Since you already have one hole, this is an easy process. Using a nail, mark all four corners of the first hole by making nail holes through the sheetrock. Then on the other side of the wall, connect the holes with a pencil mark and cut.

Sheetrock alone cannot support the weight of a 65-pound (or more) cooling system. Therefore, it is necessary to frame the hole that you have just cut with upper and lower supports. Using two two-by-fours 14.5 inches in length and eight 6d nails, secure the upper and lower supports to the right and left studs, just inside the sheetrock. Make sure that the internal height remains at 16" for the 1600, 3000 and 4200 models and 22.75" for the 6000 and 8000 models so that the WhisperKOOL system will fit snugly through the framed cut-out.

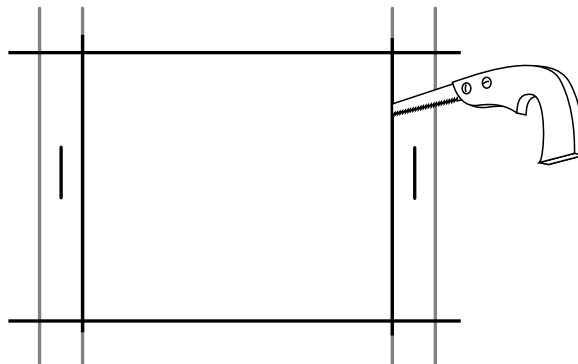

Cut vertical lines along the inside edge of the studs.

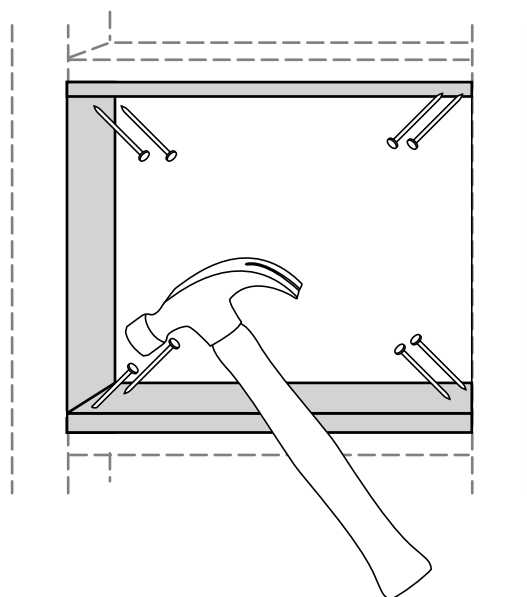

Frame the hole with two-by-four supports

INSTALLATION

Electrical Needs

The WhisperKOOL System requires a dedicated 110-volt 20-amp circuit. The unit draws a large amount of amps at initial start up. By designating a dedicated circuit breaker, you will guarantee the unit has enough power to run effectively. Contact your electrician for installation of this dedicated electrical circuit.

Electrical Outlet

The unit is equipped with two electrical outlets, one for installation inside the cellar and the other for installation outside the cellar. Both outlets are covered and have been secured with screws. Regardless of which side is utilized, the other outlet must then be covered in order to avoid a live electrical charge.

Purchase a surge protector or power conditioner to plug your WhisperKOOL unit into. As with any sensitive electrical equipment, the WhisperKOOL unit's circuitry may be damaged by power surges and spikes. Power surges and spikes are not covered by the WhisperKOOL warranty.

Do not use a Ground Fault Interrupter (GFI) with this product. The cooling unit will draw more amperage than the GFI will allow.

Upon plugging the unit in and turning it on, there will be a five minute delay before the unit starts. This is based on the function of the thermostat.

Sizing Unit to Room

The specification chart will provide information on the unit's room size cooling capacity. There are circumstances in which a cellar design may require a larger unit due to some existing design restrictions. In such a case, we recommend that the customer consider purchasing a unit with a larger capacity to compensate for the design limitations. Issues such as glass doors, concrete, or brick walls and floors may seem adequate but do not offer the insulation capacity required to maintain the optimum environment.

MODEL	AMPS (starting)	AMPS (running)	PRODUCT DIMENSIONS (H x W x D)	ROOM SIZE (cubic feet)
WK 1600	28.32	4.5	15.75" x 14.25" x 17"	300
WK 3000	30.00	6	15.75" x 14.25" x 17"	650
WK 4200	32.00	9	15.75" x 14.25" x 17"	1000
WK 6000	36.00	9.5	22.5" x 14.25" x 21.25"	1500
WK 8000	36.00	10	22.5" x 14.25" x 21.25"	2000

Carefully remove your WhisperKOOL unit from the box. Do not destroy your packing material, as it provides the only safe means of transporting the unit. Units weigh 65–100 pounds and are cumbersome for one person to carry. We recommend that you get someone else to help you during the installation process.

Testing Unit

Place the WhisperKOOL system on a tabletop to prepare it for installation and testing. Locate the by-pass plug and insert it into the thermostat plug, located on the front of the WhisperKOOL System. Next, plug the system into a live electrical outlet and turn the unit on. The system should begin cooling. The system may take up to 10 to 15 minutes before running cool. Once the operation has been tested, turn the unit off, unplug the unit from the electrical outlet, remove the by-pass plug, and install thermostat.

Note: *If the system does not seem to be running cool after 15 minutes, please refer to the Troubleshooting Guide on page 18.*

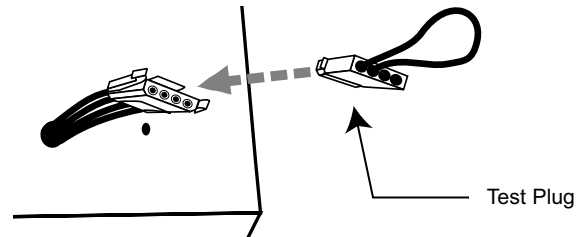

Before installation, use the by-pass test plug to test the unit.

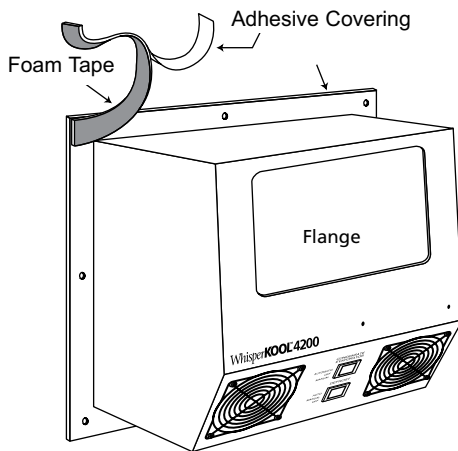

Attach precut foam tape to the unit's flange.

Applying Insulation Tape

Locate the four precut pieces of black foam tape included with your system. There should be two larger pieces and two smaller pieces. Start with the large pieces. Peel back the white-paper adhesive covering, and attach the large pieces to the sides of the unit flange. Then follow with the two smaller pieces on the top and bottom. This foam creates a tight seal between the unit's flange and the wall (see illustration).

Note: Failure to install foam strips may void the warranty.

Placement of Unit

Slide the unit from the outside wall into your wine cellar with the outer flange flush to the outside wall. Secure the flange to the wall through the predrilled holes. The screws should penetrate the studs as well as the upper and lower supports to provide adequate support for the WhisperKOOL System (see illustration). Seal all cracks and gaps around the WhisperKOOL unit with caulking to prevent air leakage. **(If you use molding, it should be attached to the walls, never to the WhisperKOOL unit itself.)**

Electrical Outlet

The unit is equipped with two electrical outlets, one for installation inside the cellar and the other for installation outside the cellar. Both outlets are initially covered and secured with screws. Select the outlet to be used and remove that cover; the unused outlet must remain covered to avoid live electrical charge.

Remove side electrical outlet cover for easy through the wall installation. Immediately replace cover when install is completed and prior to powering up unit if electrical cord is not attached to outlet.

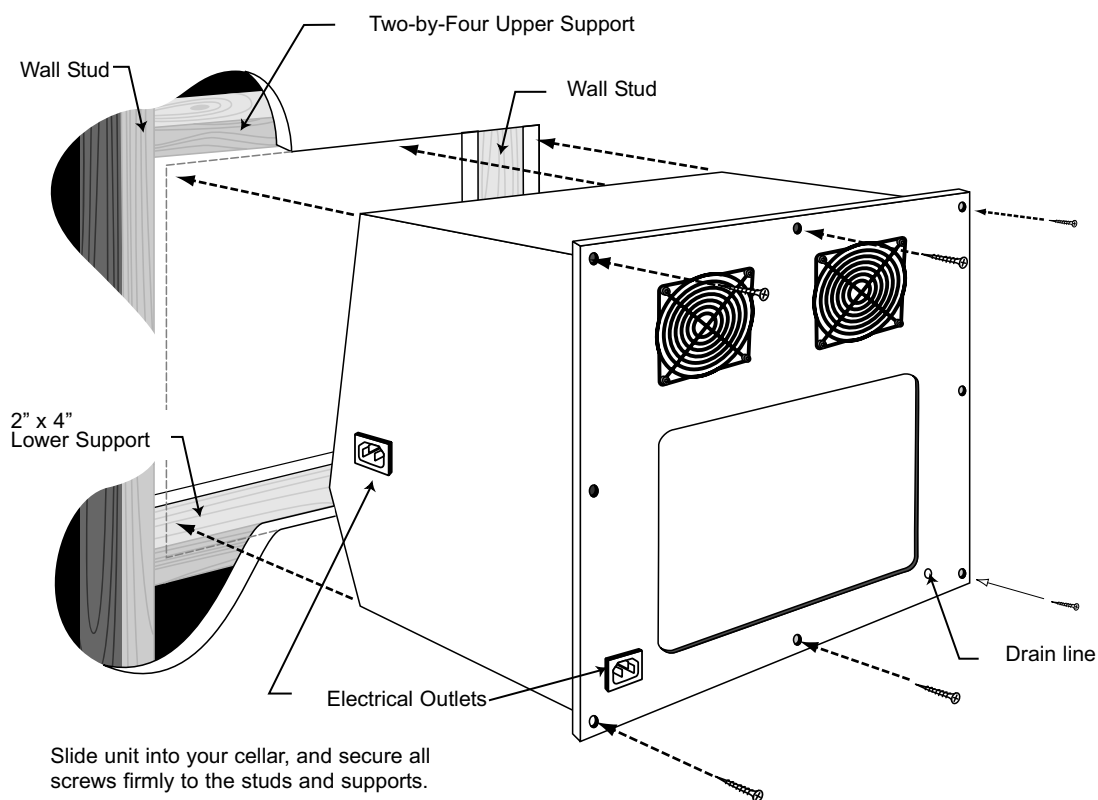

Installing Thermostat

Attach the thermostat to the front of the unit using the mounting bracket. Make sure the black male plastic plug from the unit is securely fitted into the female plug located on the circuit board of the thermostat. To complete the installation, insert the small black screws into each side of the thermostat PDT/PDT Jr. securing it to the mounting bracket. Insert the probe into a wine bottle 3/4 full of water.

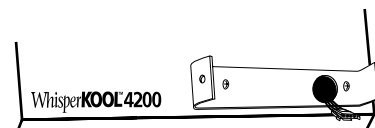

Attach the PDT mounting bracket.

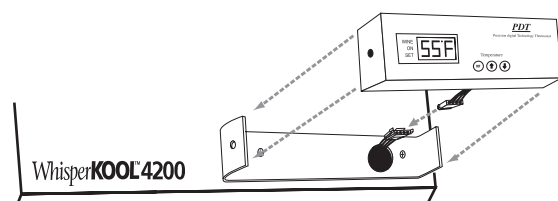

Attach the PDT to the mounting bracket.

USING THE WHISPERKOOL SYSTEM

Power Switch

The new series WhisperKOOL units come equipped with an On/Off switch. The On/Off switch is simply used when the owner does not need to utilize the equipment. Placing the power switch to the front position allows power to flow to the side outlet. Placing the switch in the rear position allows power to flow to the rear outlet.

NOTE: (It will take five minutes before the unit begins to operate once the switch is placed in the "On" position. This is due to the designed safety delay in the PDT thermostat.)

Condensate Evaporator Switch

The Condensate Evaporator is a heating element that automatically evaporates excess condensate that accumulates in the cooling system as a by-product of refrigeration. Like most cooling systems, WhisperKOOL uses heat from the compressor to evaporate and eliminate the majority of the water that accumulates during normal use. However, during certain weather conditions or in humid areas (above 80%), more condensate will accumulate than the cooling system can evaporate with heat from the compressor alone. Only the WhisperKOOL units are equipped with sophisticated heating elements that automatically sense the presence of water and work continually until the water is gone

Setting the Condensate Evaporator to the "On" setting causes the heating element and the right exhaust fan to stay on continuously to prevent excess condensation from building up in the unit.

Drain Line

All units come with a drain line for additional removal of excessive condensate. This is a back up system to the Condensate Evaporator. If the unit is installed in a high humidity area of the country, it is mandatory to install the drain line attachment. In high humidity, the cooling unit will strip excess water from the air in order to maintain the proper level of humidity within the cellar. The Condensate Evaporator will heat and dissipate the excess moisture through the rear of the unit. However in extreme humidity, additional condensate will be created. Conversely the high humidity air has less capacity to absorb additional moisture through the exhaust of the unit. Thus the drain line will prevent overflow and leaking by allowing for discharge of the additional condensate. ***Failure to install the drain line voids warranty.***

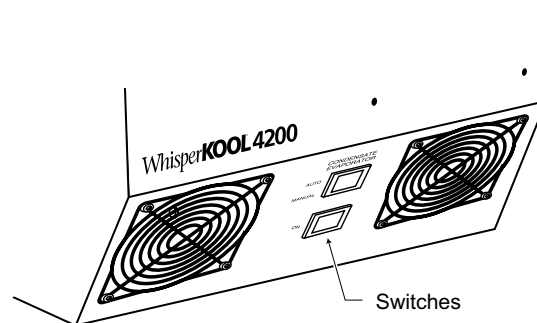

Location of control switches

LIQUID MEASURING THERMOSTAT SYSTEM

All WhisperKOOL units come equipped with our **Precision Digital Technology** (PDT/PDTJR) liquid temperature measuring thermostat system. This system incorporates the following advantages:

1. **Self-Calibrating Probe:** The probe contains a sensor chip, which actually communicates back and forth to the thermostat. This results in a consistent temperature setting and accuracy. Do not remove the tip from the probe!
2. **Built in Defrost Cycle:** The unit is designed to shut off for five minutes every ninety minutes in order to prevent frost build up. This allows the cooling unit to continue to cool effectively in demanding environments. A count down timer is observed by depressing the center button on the thermostat. (PDT upgrade version only)
3. **Heavy-duty Circuitry:** The circuitry within this new unit has been upgraded to resist power surges, which play havoc on electrical components. This improvement will ensure years of trouble-free use. However, for high reliability, we still recommend that the customer install a surge protector for the unit itself.
4. **Fahrenheit and Celsius Readout** (PDT upgrade version only): The thermostat has the ability to produce the readout in both Fahrenheit and Celsius for overseas customers. The readout can be changed by depressing both the center and right buttons at the same time.

Measuring liquid temperature has a few unique advantages:

1. Wine temperature is kept in a very precise controlled environment. This assures a consistent temperature.
2. By measuring the liquid temperature rather than air, the unit will operate 75-80% of the time. See page 2.

To Use the thermostat:

1. Locate an empty wine bottle.
2. Fill 3/4 full with room temperature tap water.
3. Place bottle probe securely into bottle.
4. Place bottle with probe level and to the side of the unit in your wine cellar.

Avoid pulling too much on the probe cord. It may become disconnected resulting in non operation of the unit.

Note: Thermostat can be set between 50°F and 76°F.

Remember: The WhisperKOOL System is **based on the temperature of the water.** Do not be misled by thermostats reading air temperature. The air temperature in the cellar will be cooler than the liquid temperature of the water while it is coming to optimum balanced temperature.

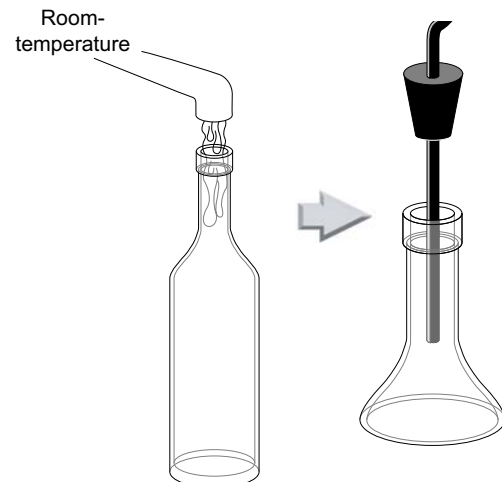

Fill an empty bottle with room-temperature water; then insert the probe.

PDT JR OPERATING INSTRUCTIONS

Operating Instructions for Vinothèque PDT JR. Thermostat

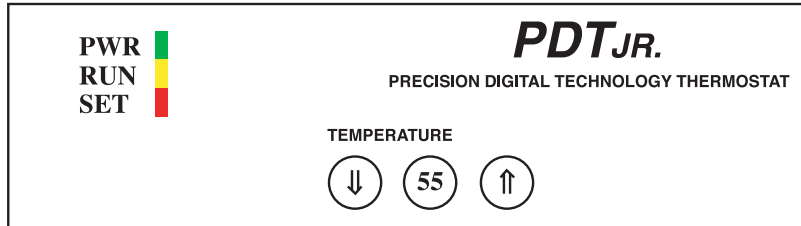

Indicators

There are three colored lights on the left side of the thermostat:

- **PWR** (Green) – When this light is on, the unit is powered.
- **RUN** (Yellow) – When this light is on, the compressor is running. If the light is flashing, the unit is currently in the five-minute lockout.
- **SET** (Red) – This light flashes when the set-point temperature is changed by pressing one of the three control buttons (see below). It flashes once for each press of the (↑) or (↓) button, and twice when the 55 button is pressed.

When the unit is first turned on, all three lights flash slowly while the thermostat starts up. Once the unit completes its start-up check, the compressor is locked out for five minutes. During this time the **RUN** light will be flashing slowly (1 flash per second).

All three lights will flash rapidly if there is no probe connected to the thermostat.

Buttons

To change the set-point temperature, press either the (↑), (↓), or (55) buttons. The SET light will flash once for each 1°F the set-point is changed. This set-point will remain in memory until you change it.

If you forget where the unit is set, pressing the (55) button will reset the set-point to 55°F and the SET light will flash twice. The temperature cannot be adjusted below 50°F or above 76°F. Attempting to set the unit outside this range will cause the SET light to rapidly flash.

Operation

Whenever the compressor shuts off normally, a five-minute lockout period begins and the **RUN** light will be flashing slowly (1 flash per second).

If the compressor runs for 90 continuous minutes, a five-minute defrost cycle is forced, during which time the compressor will not run. During this defrost cycle the **RUN** light will be flashing rapidly (2.5 flashes per second).

PDT OPERATING INSTRUCTIONS

The unit is set at 55°F at the factory. To raise or lower the set temperature, press the set button while at the same time pressing either the arrow up or arrow down button.

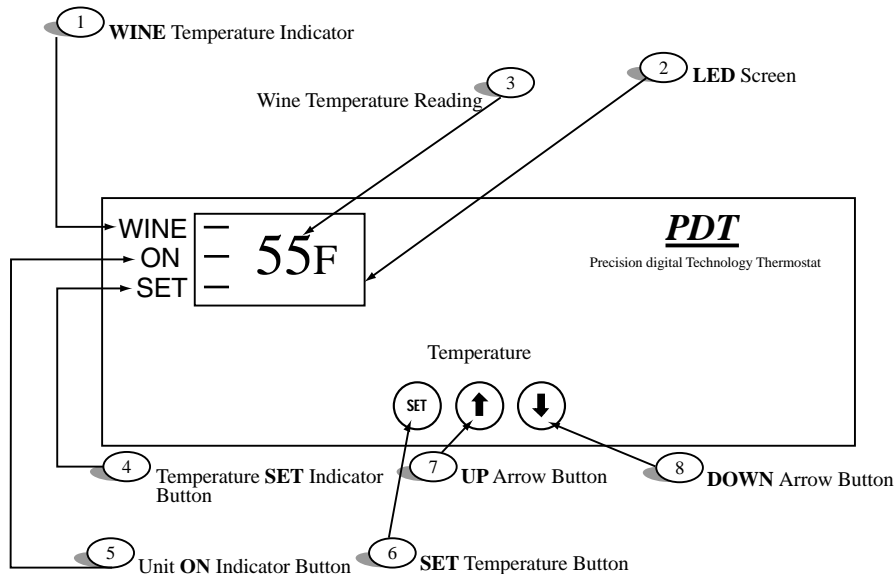

- 1. Wine Temperature Indicator:** A red LED bar will light up when the thermostat is reading the liquid temperature in the bottle via the probe. This will remain lit and the temperature you see displayed is what the probe is reading.
- 2. LED Screen:** Displays your thermostat readings.
- 3. Wine Temperature Reading:** The temperature the water bottle is registering to the thermostat.
- 4. Temperature SET Indicator:** A red LED bar will light up when you are setting the temperature.
- 5. Unit ON Indicator:** A red LED bar will light up every time the unit turns on to run a cooling cycle.
- 6. SET Button:** Used to set the temperature you want the unit to maintain.
- 7. UP Arrow Button:** Used with the SET button to set temperature higher. In addition, by pressing and holding the button it will allow you to see the 5-minute count down.
- 8. DOWN Arrow Button:** Used with the SET button to set temperature lower.

Up and Down Arrow Buttons used simultaneously will change the temperature read out from Fahrenheit to Celsius

NORMAL OPERATION

WhisperKOOL systems are designed to maintain both temperature and humidity. Once the system is installed and the temperature set, it will run continuously until the wine cellar is at your set wine temperature. This may be as much as three weeks, depending on the size of the room, the quality (R-value) of insulation, the original temperature of the wine, and the number of bottles residing in the cellar. Once the cellar has achieved the set temperature, the WhisperKOOL unit will cycle to maintain $\pm 0.5^{\circ}\text{F}$ of your set temperature.

The WhisperKOOL system will run more often than a refrigerator or air conditioner, due to its gentle cooling and humidity maintenance.

People often make the mistake of comparing the performance of refrigerators with the performance and cycling of wine storage equipment. Wine cellar cooling systems are highly specialized and designed for one purpose only—long term storage of wine.

Maintenance

The following maintenance should be performed on your WhisperKOOL unit at least once every six months to promote longevity and optimal performance.

Vacuum the back and front of the WhisperKOOL unit to clean the coils and prevent air blockage. The condenser coils reside behind the grill on the back of the WhisperKOOL unit. **Don't try to open the unit itself.** Just vacuum the surface of the grill and remove any lint or dust that has accumulated.

Humidity Control

There are no separate switches in order to maintain humidity. The cooling unit is designed to maintain relative humidity at 50-70%.

The WhisperKOOL units do not create humidity. If you live in a dry area of the country you may need to create humidity in the wine cellar. This can be done by introducing a non-heat humidifier, or installing a small fountain within the cellar.

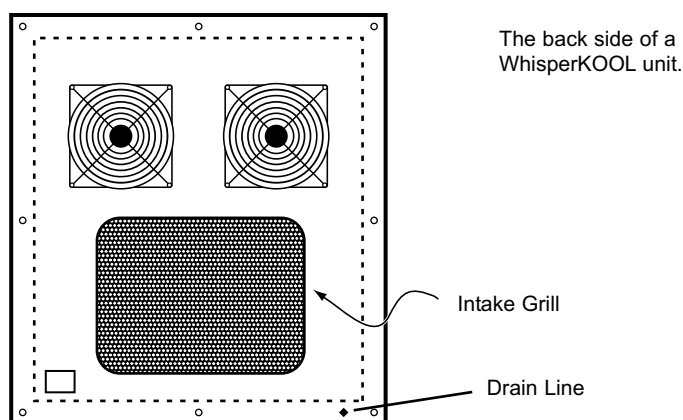

TROUBLESHOOTING GUIDE

Before contacting Customer Service regarding a performance issue with your cooling unit (does not cool, leaks, ices up...), please review the following troubleshooting information and complete the Troubleshooting Checklist found on page 23. It is designed to help you identify the issue yourself and provide appropriate advice to remedy the issue or problem.

If you are unable to identify or solve the issue after completing and following these steps, fax a completed Troubleshooting Checklist to Vinotheque Customer Service at 209.466.4606. The checklist will provide Customer Service with background information on your cooling unit installation and wine cellar to better assist you in resolving the issue. Be sure to include accurate contact information

Problem	Likely Cause	Remedy
The unit does not cool the room	Inadequate door seal Improperly mounted unit Unit has inadequate ventilation Foam strips are not attached	See "Door Seal" section on pg. 20 See "Unit Mounting" section on pg. 20 See "Airflow" and "Ventilation" sections on pg. 19 See page 11 (in the "Installation" section)
Water leaking from the rear	Condensate Evaporator is not properly set for local climate Drain line is not attached	See <i>Water Leaking, Rear</i> in the "Condensation" section on pg. 21 See "Drain line" section on pg. 21
Unit is icing up	Thermostat is faulty Unit is low on refrigerant	See "Thermostat" section on pg. 20 See "Icing Up" section on pg. 21
Unit isn't running or makes intermittent clicking noises	Problem with local electrical circuit	See "Power Requirements" section on pg. 21

Try this first!

Clean off any accumulated dust, lint, or other debris from the front and rear intake grills. This will restrict the airflow and may affect the unit's ability to function properly. Periodically cleaning the unit's vents will help assure maximum cooling efficiency.

Airflow

Proper airflow is critical to the performance of the WhisperKOOL unit. Any obstruction to the intake and exhaust ports on either side of the unit will compromise the unit's ability to cool. Make sure the WhisperKOOL unit fan vents are clear. Check the front and rear intake vents for any possible obstruction. There should be a minimum clearance of three feet directly in front of the intake and exhaust vents.

Ventilation

Proper ventilation of the WhisperKOOL unit is one of the most important and often overlooked issues associated with the unit's performance. The WhisperKOOL unit does create a large amount of heat, which needs to dissipate away from the unit freely in order to cool correctly. This issue is sometimes overlooked for several reasons:

- 1.) If there is inadequate ventilation on the rear side of the unit, this will result in further heat buildup and will



Air flows on both sides of the wall.

cause it to recirculate the hot air near the ceiling on the exhaust side of the unit, therefore limiting the ability to cool the room.

- 2.) Even though the space may seem to be adequate, the heat needs to be able to dissipate away from the unit. A lack of ventilation and air circulation will cause the room to become extremely warm.
- 3.) The WhisperKOOL unit is designed to cool 30°F cooler than the ambient temperature of the room it is exhausting the hot air to (rear side of unit). This means that in order to maintain an optimum temperature of 55°F, the temperature on the exhaust side of the WhisperKOOL unit cannot be more than 85°F.

In order to determine if ventilation may be the problem, try the following tests listed on page 25.

If the exhaust area is confined, (for example, if the unit vents into a crawlspace), then as the temperature outside the unit rises, the WhisperKOOL unit must expend more energy (and will generate more heat) in order to maintain a cool temperature inside the room. Eventually, the unit cannot keep up and the temperature inside the cellar climbs.

To solve the problem, make sure that the WhisperKOOL vents into a space of the same size or larger where heat cannot build up.

Door Seal

A high quality door with a proper seal is another important aspect of a well-designed cellar. If there is a gap between the bottom of the door and the floor, the cool air will sink and flow out beneath the door. While the release of the cool air may be subtle, it will require the WhisperKOOL unit to continue to operate without achieving the desired results. Use good-quality weather-stripping and seals

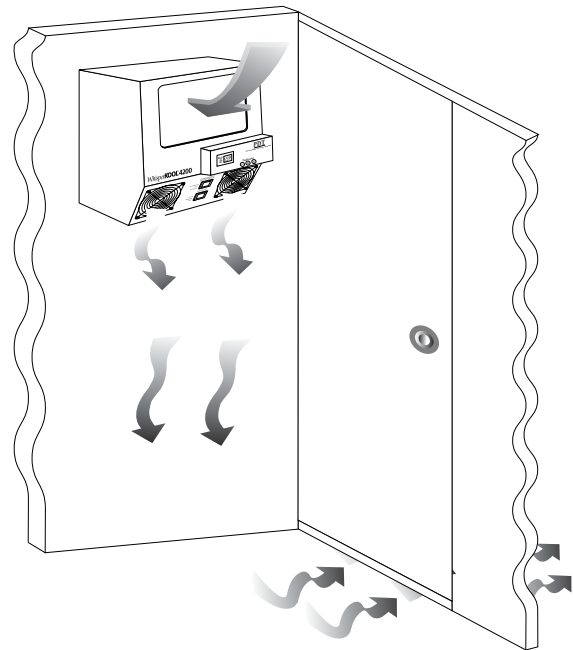

Cool air drops and exits beneath door.

around the cellar door to prevent cool air leakage. For more details, see Preparing the Wine Cellar, "Door" on page 6.

Unit Mounting

Mounting the unit in the cellar has a significant impact on the unit's ability to cool the air in the room. A law of nature states that warm air rises while cool air falls. The unit must be mounted high in the room in order to capture the warm air and replace with cool air. If the unit is mounted low in the cellar, it has a tendency to circulate the cool air at the

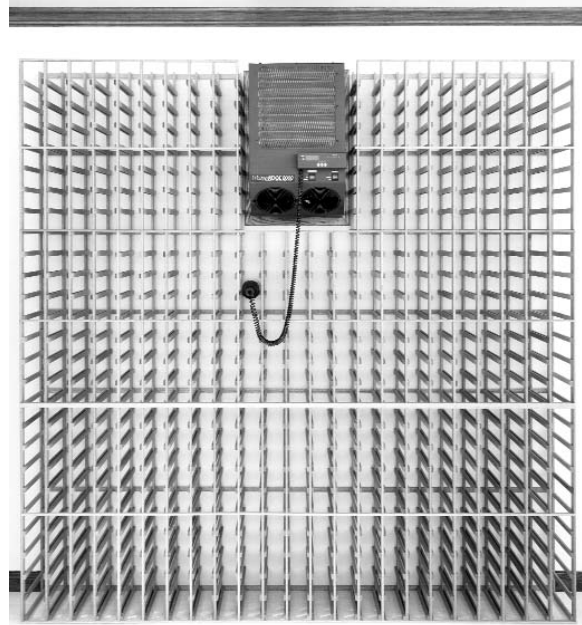

Mount WhisperKOOL high in the room.

bottom of the cellar but has no ability to draw the warm air from the higher space in the cellar. This will result in an inconsistent temperature range.

Thermostat

If the WhisperKOOL unit is not cooling the room, it might be due to a faulty thermostat. Use the following procedure to test the thermostat (see pg. 25).

- 1.) Unplug the WhisperKOOL unit.
- 2.) The PDT thermostat is attached to the front of the WhisperKOOL unit with two screws, one at each end of the thermostat. Remove the screws and detach the PDT.
- 3.) Unplug the PDT from the main unit, and plug in the by-pass plug. The by-pass plug lets you run the WhisperKOOL without having the

thermostat installed.

- 4.) Plug the WhisperKOOL unit back in. The unit will begin running and cooling immediately. Let the unit run for 24 hours.
- 5.) After 24 hours, use an accurate thermometer (preferably a high-quality digital thermometer) to measure the temperature of air coming out of the WhisperKOOL unit's front fans. If it is cooling the room, then the problem may lie with the thermostat.

If the WhisperKOOL unit cools the room without the PDT installed, then the thermostat should be replaced. The by-pass plug will allow the WhisperKOOL unit to continue to function, but it will not be able to monitor or maintain the correct temperature automatically without the thermostat.

If you continue to run the WhisperKOOL on the by-pass plug without the thermostat, you will need to turn off the WhisperKOOL unit periodically to keep it from icing up. We recommend cycling the unit on and off every eight hours if possible or as needed.

For replacement of the PDT, please contact Customer Service. See Warranty Service on page 29.

Condensation

Water Leaking, Rear

The WhisperKOOL product is designed to dissipate excessive moisture by collecting it in the compressor pan and using the natural compressor heat along with a heating element to remove condensation.

Operating the WhisperKOOL in excessively humid conditions can cause the unit to accumulate more condensation (water) than the unit can dissipate while operating, resulting in leakage. In order to resolve this issue, the unit is designed with both a Condensate Evaporator control switch and an external drain line (see page 13). The Condensate Evaporator switch will allow you to operate the heating element continuously whether the unit is operating or not. (See Condensate Evaporator on page 13.)

Icing Up

In the unlikely event that your WhisperKOOL unit is icing up in front, unplug the unit for 24 to 36 hours and allow the ice to melt away. Plug the unit back in and **test on the by-pass plug for 24 hours** (refer to page 20 and 25). Within the 24 hour period the unit should not develop ice and should be generating cold air. If the unit is functioning properly when on by-pass, the icing may have been a result of a faulty thermostat (see page 20). If while on by-pass, the unit continues to form ice, first check that all 4 fans are working. Secondly, check to see if the unit is blowing cold air. If the air is cool to luke warm, but not cold, the unit requires further service.

Please contact Customer Service for assistance and guidelines. Before contacting Customer Service, see pages 23-26.

Power Requirements

When the WhisperKOOL starts to operate, it draws several times more power (amps) during the start-up cycle than it does during normal operation. Make sure you have the WhisperKOOL on a dedicated electrical line at a minimum of 20 amps. See the Product Information Table on page 10 to find the correct amperage requirement for your unit.

Make sure that the power line for the WhisperKOOL does not have any additional equipment installed on that circuit. An extra load on the line may be drawing power away from the WhisperKOOL unit. In some cases it may not be readily apparent that an additional appliance or electrical device has been installed on the circuit breaker. In addition, the unit may not be used on an electrical line with a Ground Fault Interrupter (GFI). The WhisperKOOL will draw more amperage than the GFI will allow.

Repairing Units - Removing Rivets

Only a certified HVAC tech should work on the units. We do not want owners opening the units for their own safety.

1. Unplug the WhisperKOOL unit.
2. Remove the WhisperKOOL unit from the wall mounting and set it on a sturdy work-bench.
3. Drill out the rivets on the top panel that hold the case together, using a 3/32 (size) drill bit. This will destroy the rivets.
4. Remove the top off of unit, and carefully remove the insulation (if any) from the top.
5. When replacing the panel, you can use rivets or small metal 6-32 3/8" Phillips Pan Head Screws. It is recommended to locate any necessary parts at your local hardware store prior to the service.

Consumer Care Program

The Consumer Care Program is designed to expedite the shipment of a replacement unit to your location quickly in order to get your cellar cooling again.

This program involves contacting our Customer Service department to purchase a refurbished unit in exchange for your original unit. You will receive a unit which has undergone our five star refurbishment program. The unit is tested in our controlled environment and is ready for immediate use.

Upon receiving the unit, you will be required to repackage your old unit and ship it back to the factory within 30 days.

Complete details of our program including pricing are available by contacting our Customer Service department.

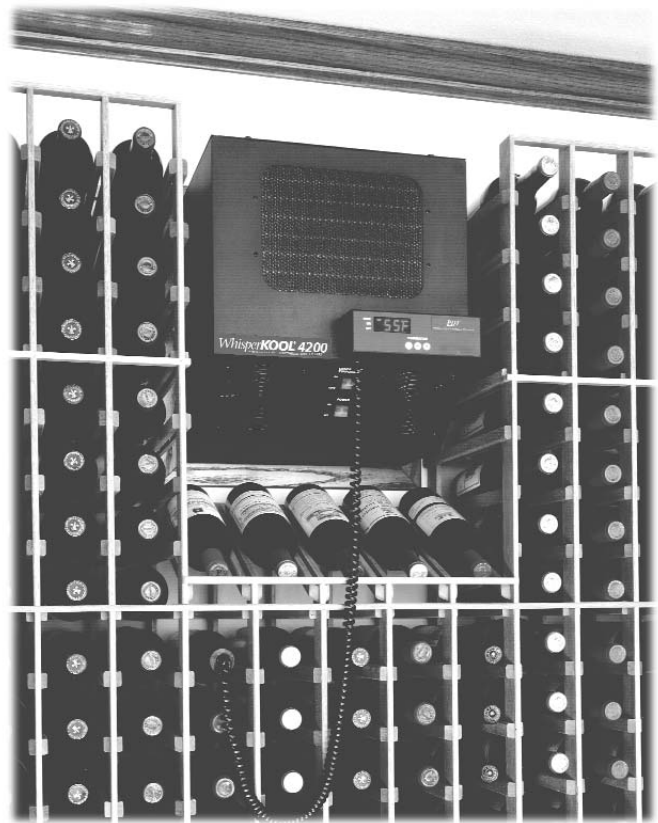

TROUBLESHOOTING CHECKLIST

Please fill out this checklist to help identify the issue or problem with the performance of the cooling unit. If you still require technical assistance, fax a copy of this Troubleshooting Checklist to Vinotheque Customer Service at 209.466.4606. Be sure to include accurate contact information.

Customer Name: _____ Phone: _____

Email address: _____

Unit model: _____ Serial Number: A _____

General Inspection

Unit Installation

- | | | | |
|----|---|------------------------------|-----------------------------|
| 1) | Is the unit installed in the correct direction, with front side of unit in wine cellar and back side in exhaust room/space? Refer to page 12 of the owner's manual. | Yes <input type="checkbox"/> | No <input type="checkbox"/> |
| 2) | Is the unit mounted within 18" from ceiling to allow proper air circulation? Refer to page 6 of the owner's manual. | Yes <input type="checkbox"/> | No <input type="checkbox"/> |

Wine Cellar

- | | | | |
|----|--|------------------------------|-----------------------------|
| 3) | Is the cellar door sealed properly? To check, make sure cellar door is closed and lights are turned off within cellar; light from outside should not be visible through any of the four sides around the door. | Yes <input type="checkbox"/> | No <input type="checkbox"/> |
| 4) | Are there any glass windows and/or glass doors in the cellar? | Yes <input type="checkbox"/> | No <input type="checkbox"/> |
| 5) | What is the R value of the walls? _____ What is the cellar room size? _____ | | |
| 6) | Are any of the cellar walls in the direct path of the sun? | Yes <input type="checkbox"/> | No <input type="checkbox"/> |
| 7) | Are any of the walls on an exterior wall? | Yes <input type="checkbox"/> | No <input type="checkbox"/> |
| 8) | Is there foam attached to the flange of the Whisperkool unit? See page 8 of the owner's manual. | Yes <input type="checkbox"/> | No <input type="checkbox"/> |

General Ventilation

- | | | | |
|-----|--|------------------------------|-----------------------------|
| 9) | Is there at least 3' of unobstructed clearance for the fans and grills on the unit? Obstructions to the air flow greatly reduce the effectiveness of the unit's ability to cool the cellar. Refer to page 7 of the owner's manual. | Yes <input type="checkbox"/> | No <input type="checkbox"/> |
| 10) | Are there any decorative plates/covers on the unit? If so, remove them. They obstruct air flow to and from the vents. Refer to page 7 of the owner's manual. | Yes <input type="checkbox"/> | No <input type="checkbox"/> |
| 11) | Is the unit on top of, in, or surrounded by shelving? Nearby flat surfaces, such as shelving, may obstruct air circulation and ventilation. | Yes <input type="checkbox"/> | No <input type="checkbox"/> |
| 12) | Are all four fans in the unit operating? (Two are in the front, and two are in the back.) | Yes <input type="checkbox"/> | No <input type="checkbox"/> |

Exhaust Room/Space Ventilation:

- | | | | |
|-----|--|------------------------------|-----------------------------|
| 13) | Into what kind of room/space is the unit exhausting? To Outside <input type="checkbox"/> Crawl Space <input type="checkbox"/> Utility Space <input type="checkbox"/> | | |
| 14) | Is the exhaust room/space as large as or larger than the cellar? | Yes <input type="checkbox"/> | No <input type="checkbox"/> |
| 15) | Is the exhaust room/space warm? | Yes <input type="checkbox"/> | No <input type="checkbox"/> |
| 16) | What is the temperature? _____ | | |
| 17) | Is there any ventilation into and out of the exhaust room/space? Please describe. Refer to page 7 of the owner's manual. | Yes <input type="checkbox"/> | No <input type="checkbox"/> |
| 18) | Have the coils in the front and back of the Whisperkool unit been vacuumed? | Yes <input type="checkbox"/> | No <input type="checkbox"/> |

Specific Performance Issues:

Unit is Not Cooling Sufficiently or Not Cooling at All:

- 19) On a thermostat with digital readout, what is the set temperature? To check, hold down the "SET" button on the thermostat to see the set temperature. Refer to page 16 of the owner's manual. Set Temp:
- 20) What is the actual temperature of the cellar? Temp:
*To check air temperature, use a digital thermostat which can be purchased at any hardware store under kitchen supplies.
- 21) On a thermostat with digital readout, does the thermostat display two horizontal dashes or the letters "PRB"? (This indicates a problem with the thermostat.) Yes No
- 22) Is the probe inserted into a bottle of water? Refer to page 14 of the owner's manual. Yes No

Water is Leaking from the Unit:

All units come with a drain line for additional removal of excess condensate, as a back up system to the Condensate Evaporator which is used to maintain proper humidity. It is critical to install the drain line attachment for the unit to function effectively, preventing overflows and leaks from build up of condensate. See page 13.

Failure to install drain line will void warranty.

- 23) Is the unit level? Yes No
- 24) Is the drain line attached? Yes No
- 25) Is the unit leaking from the back?
This is generally due to an improper setting on the condensate evaporator. In high humidity regions, the condensate evaporator should be set to "ON" while other regions should be set to "AUTO".
Refer to page 13 of the owner's manual. Yes No

Unit is Icing Up:

- 26) Is the unit icing up? Allow the unit to thaw for 24-36 hours and ensure that there is adequate air flow to and from the unit before operating again. Obstructed airflow is a possible reason why units ice up. Refer to page 21 of the owner's manual. Yes No

Unit Short Cycles, Clicks Intermittently, Trips Breaker, or does not Run:

- 27) Is there power being supplied to the outlet? To check, test the outlet using a small appliance (hairdryer). Yes No
- 28) Is the unit on a GFI (Ground Fault Interrupter)? The unit should not be run on a GFI. Refer to page 10 of the owner's manual. Yes No
- 29) Does the unit have a dedicated electrical line and 20 amp circuit breaker? To check, examine the breaker box to see if the cellar is on its own circuit. Refer to page 21 of the owner's manual. Yes No
- 30) Are there any large appliances plugged into the same room or in the same area of the building of the cooling unit? Refer to page 21 of the owner's manual. Yes No

TEMPERATURE DIFFERENTIAL TESTING

The purpose of this test is to evaluate whether or not your cooling unit is operating correctly by measuring the temperatures of both the inside of the cellar and the exhaust side of the unit in the adjoining room. The majority of problems found with cooling units result from inadequate ventilation on the exhaust (back) side of the unit; therefore, taking these measurements is critical in ensuring the optimal performance of the product while minimizing costs of operation.

The WhisperKOOL unit is designed to maintain relative humidity between 50-70%, which is accomplished by cooling the cellar slowly. You should anticipate an approximate 10 - 15 degree temperature differential between the inlet air temperature and the outlet air temperature on the evaporator (front) side of the unit.

When testing the air temperature, please hold the thermometer in the appropriate location for a full minute before recording temperatures so that the thermometer has stabilized. ***Do not use PDT Probe! ****

Please refer to the images at the end of the document as a guide to where to measure the temperature of the inlet/outlet air:

*Note: to check air temperature, use a digital thermostat which can be purchased at any hardware store under kitchen supplies.

First Temperature Test:

1. Stabilize the unit by turning it on and letting it run for five minutes before performing the first temperature test.
2. Measure temperature of the inlet air going into the cooling unit on the evaporator (front) side.
3. Measure temperature of the outlet air discharging out of the cooling unit on the evaporator (front) side by holding the thermometer at the outer edge of the circular fan.
4. Record information and calculate temperature differential in table below for the evaporator (front) side section under the first test.
5. On the back side of the unit, measure temperature of the inlet air going into the cooling unit on the condenser (back) side.
6. On the back side of the unit, measure temperature of the outlet air discharging out of the cooling unit on the condenser (back) side by holding the thermometer at the outer edge of the circular fan.
7. Record information and calculate temperature differential in table below for the condenser/back side section under the first test.

Second Temperature Test:

8. After the unit has run for 8 hours, perform the second temperature test.
9. Record information and calculate temperature differential in table below for the condenser/back side section under the second test.

Third Temperature Test:

10. After the unit has run for 24hours, perform the third and last temperature test.

11. Record information and calculate temperature differential in table below.

Temperature Data from Testing

	Temperature \ Test (time)	First (after 5 mins)	Second (after 8 hrs)	Third (after 24 hours)
Evaporator (Front) Side	Inlet Air			
	Outlet Air			
	Differential (Inlet - Outlet = _; ideally 10°F-15°F)			
Condenser (Back) Side	Inlet Air (ideally <90°F)			
	Outlet Air (ideally <120°F)			
	Differential (Inlet - Outlet = _; ideally around 30°F)			

Temperature Testing Locations

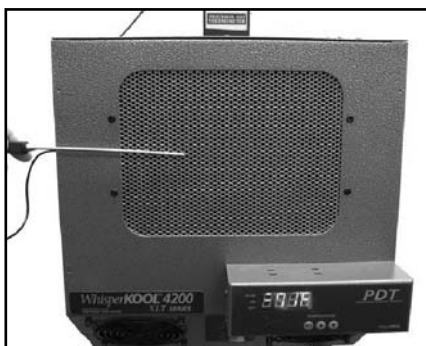

Inlet Air – Evaporator (Front) Side



Outlet Air – Evaporator (Front) Side*

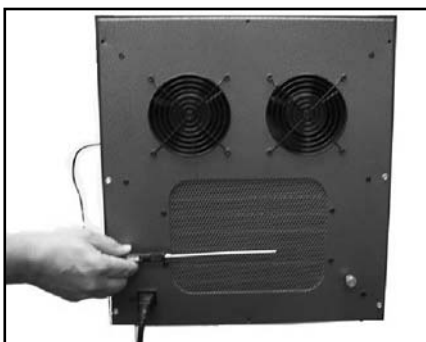

Inlet Air – Condenser (Back) Side•

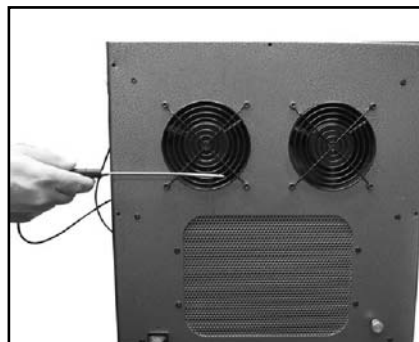

Outlet Air – Condenser (Back) side*

*When measuring outlet air temperature on both sides of the unit (from the circular fans), hold the thermostat at the outer edges of one of the circular fans.

Conclusions

After completing the temperature differential test, determine if the unit is not cooling at all or if it is not cooling enough.

If the unit is not cooling at all, contact Vinothèque Customer Service at 800.343.9463. Be sure to have the measurements and results from your Temperature Differential test available.

If the unit is cooling but not cooling fully (with a evaporator differential of 10°F-15°F and a condenser differential of approximately 30°F), it indicates that there is too much heat on the back side of the unit. In this case, you should:

- Check to make sure that there is at least 3' of unobstructed space in front of the fans/vents to allow adequate ventilation. Improper ventilation causes the majority of problems with cooling units.
- On the condenser side, if the inlet air temperature is >90°F and/or the outlet air temperature is >120°F, there is too much heat on the back side of the unit which is preventing it from cooling fully. To remedy this, heat needs to be dissipated away from the unit through an exhaust fan or other means of ventilation on the exhaust side. You can contact Vinothèque Customer Service to request a ducting flange adapter at no charge to assist in directing heat away from the unit (for warranty units only).
- You might consider installing a Vinothèque approved ventilation ducting system for your unit which can be obtained through Vinothèque Customer Service.
- Contact Vinothèque Customer Service at 800.343.9463. Be sure to have the measurements and results from your Temperature Differential test available.

TECHNICAL ASSISTANCE

Vinothèque Customer Service is available Monday through Friday from 8:00 a.m. to 4:00 p.m. Pacific Standard Time.

Please make sure that you have the following information available before you call:

- The model and serial number of your WhisperKOOL unit.
- Type of thermostat used with your WhisperKOOL.
- Location and installation details, such as ventilation, construction and size of room.
- Photos of installation of unit from 10 to 15 feet away, front and back.
- Completed Troubleshooting Checklist and Temperature Differential Testing form.

How To Contact Vinothèque Customer Service

Telephone	(209) 466-9463 (800) 343-9463
Fax	(209) 466-4606
Website	www.vinotheque.com
Address	Vinothèque Wine Cellars 1738 East Alpine Avenue Stockton, CA 95205

INSTALLATION TERMS AND CONDITIONS

WHISPERKOOL XLT/EXTREME COOLING SYSTEM

ATTENTION: PLEASE READ THESE TERMS OF USE CAREFULLY BEFORE INSTALLING YOUR WhisperKOOL XLT/Extreme Cooling System. INSTALLING YOUR WhisperKOOL XLT/Extreme Cooling System INDICATES THAT YOU ACCEPT AND AGREE TO EACH OF THE TERMS AND CONDITIONS SET FORTH HEREIN ("TERMS OF USE"). IF YOU DO NOT ACCEPT THESE TERMS OF USE, YOU RISK VOIDING YOUR WARRANTY AND ASSUMING ADDITIONAL REPAIR AND REPLACEMENT COSTS.

1. Acceptance of Terms and Conditions Use and installation of a WhisperKOOL XLT/Extreme Cooling System assumes that the consumer ("user") fully accepts and agrees to the Terms and Conditions set forth in this document. The Terms and Conditions also state that, by signing and returning this document, you are certifying you have read, understood, and agreed to our Terms and Conditions, as well as our User's Manual. The User's Manual is shipped with each unit and, if another copy is needed, replacement copies can be downloaded from the company website (www.vinotheque.com) or by contacting Vinothèque Wine Cellars ("Vinothèque") directly for a new copy. Vinothèque reserves the right, in its sole discretion, to change its Terms and Conditions at any time, for any reason, without notice.

2. Product Installation

Subject to these Terms and Conditions, when the user purchases a WhisperKOOL XLT/Extreme Cooling System, the user agrees to read and follow the required installation procedures set forth by Vinothèque for proper use and installation of the Product.

- (a) It is highly recommended that you obtain the assistance of a wine storage professional.
- (b) Failing to address all of the variables associated with proper installation will cause the unit to operate incorrectly and limit its ability to cool and the longevity of the unit itself.
- (c) The warranty card must be returned to Vinothèque, the manufacturer, to ensure registration guaranteeing the full warranty period is granted. Failure to register the product within thirty (30) days of installation may result in a loss of warranty.
- (d) The user is responsible for the full costs of installation and any additional parts required for the proper and complete installation of the Product.
- (e) The WhisperKOOL XLT cooling system cannot operate at its optimum capacity if airflow is constricted by ducting or venting the exhaust side of the unit into a location with inadequate ventilation.

3. Product Warranty Information

If a problem arises with your WhisperKOOL system during the warranty period, you must contact Vinothèque Customer Service for warranty coverage and repairs. Removing the rivets from the unit housing without authorization from the manufacturer will VOID the warranty. Please contact a customer service representative for assistance before beginning work on a WhisperKOOL unit that is still under the two (2) year manufacturer warranty.

For XLT/Extreme Cooling Systems returned to Vinothèque following warranty guidelines, Vinothèque warrants this product against defects in material or workmanship as follows:

- (a) **LABOR:** For a period of two (2) years from the date of purchase. If this Product is found to be defective after undergoing customer service troubleshooting, Vinothèque will repair or replace the product, at its option and discretion, at no charge to the customer. After the Warranty Period, the customer is responsible for ALL labor and freight charges.
- (b) **PARTS:** Vinothèque will supply, at no charge, new or rebuilt replacement parts in exchange for defective parts for a period of two (2) years.

(c) **FREIGHT:** During the first two (2) years from the date of purchase, Vinothèque will cover freight for the repair of units **UNDER WARRANTY** to customers within the continental United States.

This warranty does not cover cosmetic damage caused during installation or damage due to acts of God, accident, misuse, abuse, negligence, or modification to any part of the product. This warranty does not cover damage due to improper operation or lack of proper maintenance, connection to improper voltage supply, or attempted repair by anyone other than a technician approved by Vinothèque to service the product. This warranty does not cover products sold "AS IS" or "WITH ALL FAULTS." This warranty is valid only in the continental United States.

Proof of purchase in the form of a bill of sale or receipted invoice, which is evidence that the product is within the warranty period, must be presented to obtain warranty service. This warranty is void if the factory-applied serial number has been altered or removed from the product.

REPAIR OR REPLACEMENT AS PROVIDED UNDER THIS WARRANTY IS THE EXCLUSIVE REMEDY OF THE CONSUMER. VINOTHÈQUE SHALL NOT BE LIABLE FOR ANY INCIDENTAL OR CONSEQUENTIAL DAMAGES FOR BREACH OF ANY EXPRESS OR IMPLIED WARRANTY ON THIS PRODUCT. EXCEPT TO THE EXTENT PROHIBITED BY APPLICABLE LAW, ANY IMPLIED WARRANTY OF MERCHANTABILITY OR FITNESS FOR A PARTICULAR PURPOSE ON THIS PRODUCT IS LIMITED IN DURATION TO THE DURATION OF THIS WARRANTY.

Some states do not allow the exclusion or limitation of incidental or consequential damages, or allow limitations on how long an implied warranty lasts, so the above limitations or exclusions may not apply to you.

This warranty gives you specific legal rights and you may have other rights which vary from state to state.

4. Maintenance

It is the user's responsibility to remove any accumulated dust, lint, or other debris from the front and rear intake grilles. This will restrict the airflow and may affect the unit's ability to function properly. Periodically cleaning the unit's vents will help assure maximum cooling efficiency. The drain tube must also be checked and kept clean and free of debris and mold to maintain proper performance.

Mold is a natural living organism in the environment. It exists in the air in the form of microscopic spores that move in and out of buildings through doors, windows, vents, HVAC systems and anywhere else that air enters. Once it is discovered, mold must be addressed quickly and appropriately. Delayed or improper treatment of mold issues can result in costly and recurring repairs. If you suspect you have a mold problem, it is always best to hire a qualified and experienced mold remediation specialist.

5. User Costs and Responsibility

The following items are not covered under warranty and are the sole responsibility of the user.

(a) The user is responsible for ALL initial installation costs, including, but not limited to, labor costs and the cost of any additional parts necessary to complete the installation.

(b) The user is responsible for the costs incurred for installation and removal of the product or any part thereof unless it has been defined as a warranty repair **PRIOR** to the work being performed.

(c) Purchasers (users) are reminded that they should satisfy themselves that the product they are purchasing is suitable for their needs and requirements and no responsibility will be placed with Vinothèque for their decisions.

(d) It is the user's responsibility to secure safe haven/storage for ANY AND ALL items that are being kept and stored in the user's wine cellar. Vinothèque takes no responsibility for the safety and preservation of the aforementioned items in the event that the environment becomes unsuitable for proper storage

6. State Sales Tax

We collect California Sales Tax only for orders made and shipped within California. We do not collect sales tax for orders shipped to other states. However, you may be liable for sales tax to your state for the merchandise you receive. You may want to check with your state's tax authority for "use tax" regulations.

7. Customer Service

Vinothèque's customer service department is available Monday through Friday, from 8:00AM to 4:00PM PT by calling 1-800-343-9463.

8. Trouble Shooting

The customer service department is available to answer any questions or inquiries regarding our product as well as to assist in basic and primary troubleshooting for any problems with our product.

9. General Provisions

(a) Construction and severability. Every provision of these Terms and Conditions will be construed, to the extent possible, so as to be valid and enforceable. If any provision of these Terms and Conditions so construed is held by a court of competent jurisdiction to be invalid, illegal or otherwise unenforceable, such provision will, to the extent so held, be deemed severed from these Terms and Conditions, and all other provisions will remain in full force and effect.

(b) Governing Law/Choice of Forum. The laws of the State of California (without regard for conflicts of law) shall govern the construction and enforcement of these Terms and Conditions, except that the Terms and Conditions shall be interpreted as though drafted jointly by Vinotheque and the Purchaser. Any dispute will be resolved in a state or federal court situated in the County of Santa Clara, State of California, and the

Purchaser hereby irrevocably submits to the personal jurisdiction of such courts for that purpose.

(c) Entire Agreement/No Waiver. These Terms and Conditions and the Limited Warranty incorporated herein by reference set forth the entire agreement between the parties and supersede all prior agreements or understandings, both written and oral, between the parties regarding the subject matter of this the Terms and Conditions and the Limited Warranty. The parties may modify these Terms and Conditions or the Limited Warranty only in a writing signed by each. No waiver by Vinothèque of any breach or default hereunder will be deemed to be a waiver of any preceding or subsequent breach or default.

(d) Correction of Errors and Inaccuracies. These Terms and Conditions may contain typographical errors or other errors or inaccuracies. Vinothèque reserves the right to correct any errors, inaccuracies or omissions, and to change or update these Terms and Conditions, at any time, without prior notice.

10. Questions or Additional Information

If you have any questions regarding these Terms and Conditions or wish to obtain additional information, contact us via phone at 1-800-343-9463 or please send a letter via U.S. Mail to:

Vinothèque Wine Cellars
1738 E. Alpine Ave
Stockton, CA 95205



Vinothèque

WINE CELLARS

1738 East Alpine Avenue

Stockton, California 95205

www.vinotheque.com

Free Manuals Download Website

<http://myh66.com>

<http://usermanuals.us>

<http://www.somanuals.com>

<http://www.4manuals.cc>

<http://www.manual-lib.com>

<http://www.404manual.com>

<http://www.luxmanual.com>

<http://aubethermostatmanual.com>

Golf course search by state

<http://golfingnear.com>

Email search by domain

<http://emailbydomain.com>

Auto manuals search

<http://auto.somanuals.com>

TV manuals search

<http://tv.somanuals.com>