

EXTREME SERIES OWNER'S MANUAL

Platinum 4000
Platinum 8000
8000ti

*Whisper***KOOL**[™]
The Coolest Thing In Wine Storage

Copyright © 2010. WhisperKOOL. All rights reserved.

This manual, the product design, and the design concepts are copyrighted by WhisperKOOL, with all rights reserved. Your rights with regard to the hardware and manual are subject to the restrictions and limitations imposed by the copyright laws of the United States of America. Under copyright laws, this manual may not be copied, reproduced, translated, transmitted, or reduced to any printed or electronic medium or to any machine-readable form, for any purpose, in whole or in part, without the written consent of WhisperKOOL.

Every effort has been made to ensure that the information in this manual is accurate. WhisperKOOL is not responsible for printing or clerical errors.

WhisperKOOL reserves the right to make corrections or improvements to the information provided and to the related hardware at any time, without notice.

Vinothèque and WhisperKOOL are registered trademarks, and ECE is a trademark of WhisperKOOL. All rights reserved.

Mention of third-party products is for informational purposes only and constitutes neither an endorsement nor a recommendation. WhisperKOOL assumes no liability with regard to the performance or use of these products.

07.27.10

TABLE OF CONTENTS

WhisperKOOL Extreme Series Quick Reference Guide	4
Controller Quick Reference Guide.	5
Introduction	6
Receiving & Inspecting The Unit	7
Preparing the Wine Cellar	8
Installation	13
Through-The-Wall Installation	14
Installation Options	17
Ducted Installation.	18
Remote Controller	22
Liquid Measuring Thermostat System.	24
Variable Speed Control.	25
System Operation: Standard and Remote	26
Control Panel Features and Operation	27
Maintenance Schedule.	30
Troubleshooting Guide.	31
Technical Assistance	33
Installation Terms and Conditions	34

WHISPERKOOL Series QUICK REFERENCE GUIDE

Front / Side View

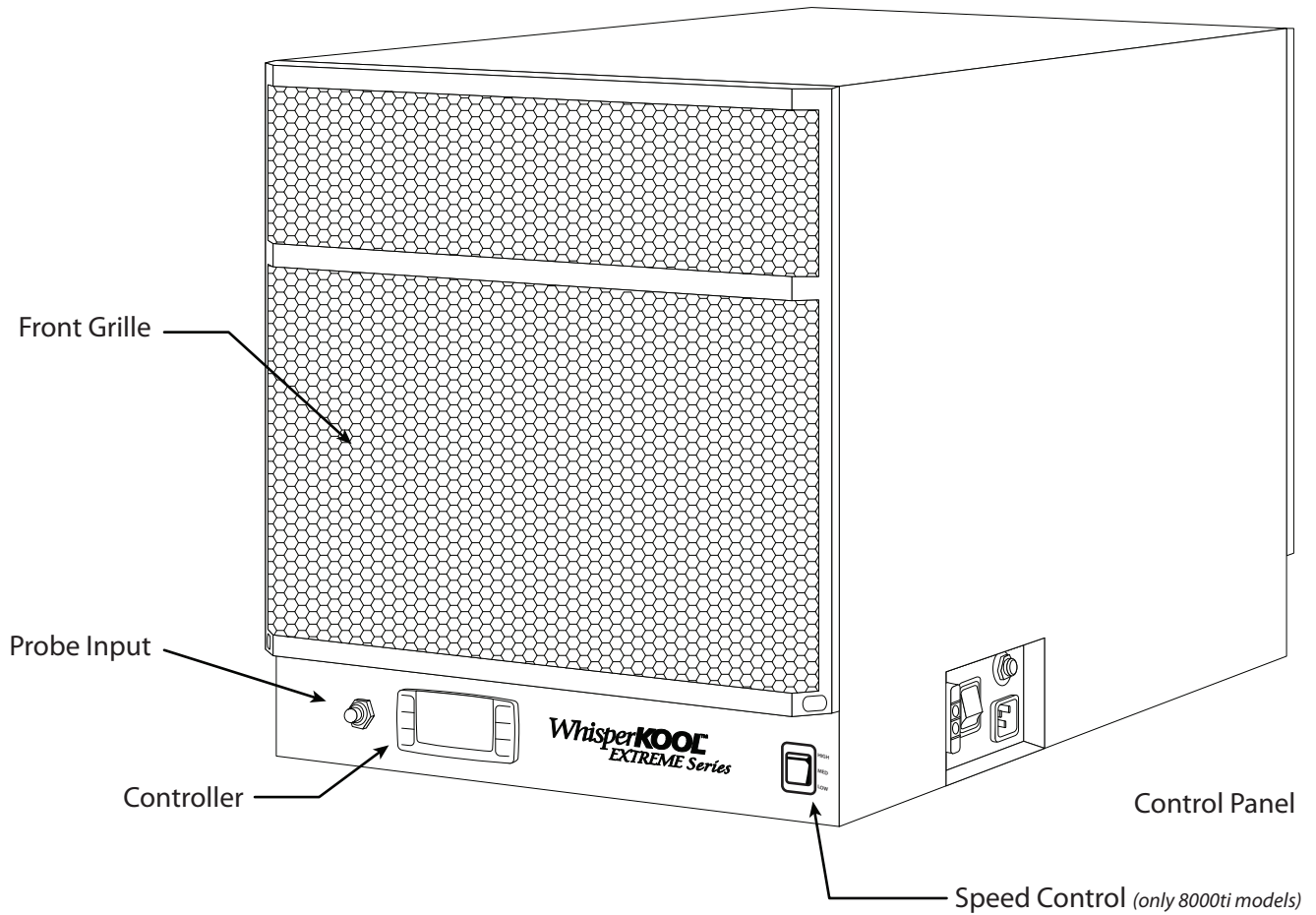

Rear View

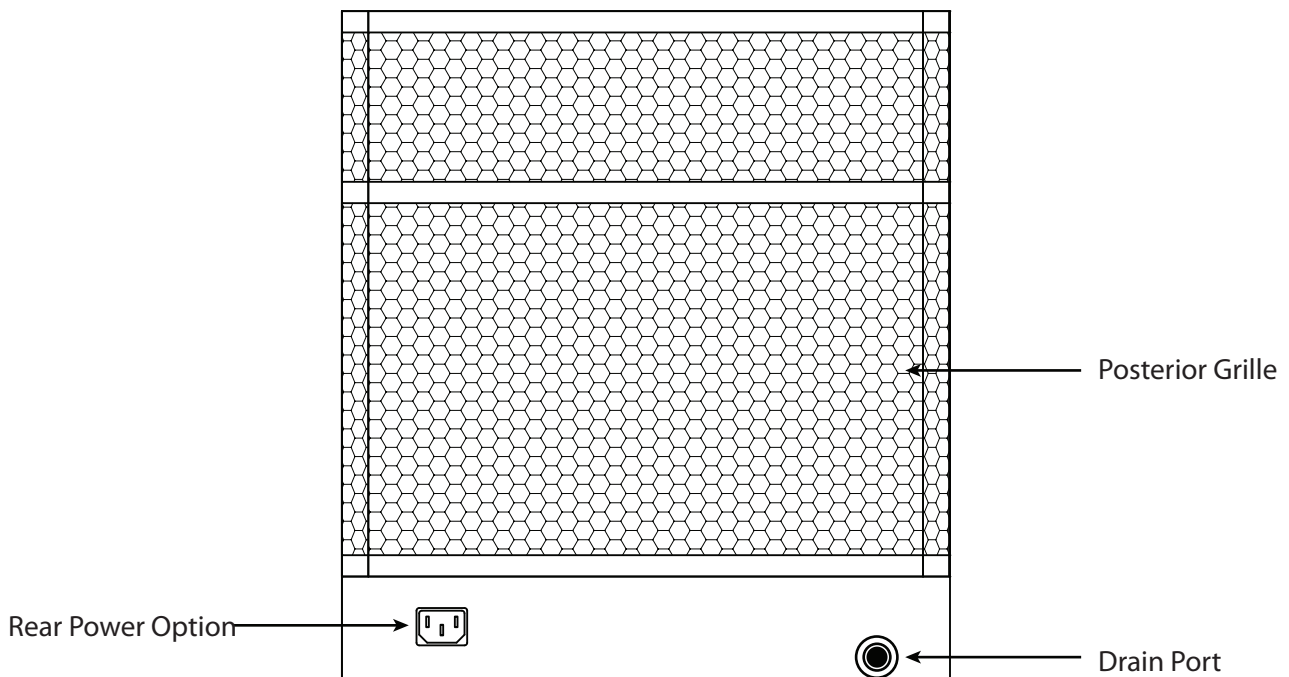

CONTROLLER QUICK REFERENCE GUIDE

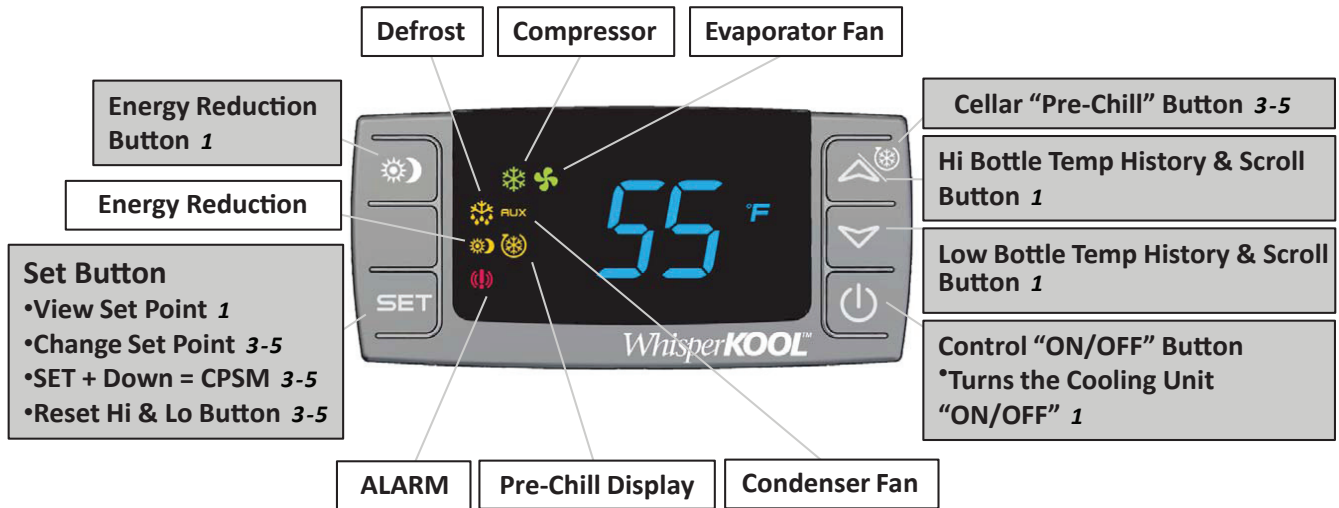

Note: The 1 or 3-5 qualifies the amount of time in seconds that the button must be pushed to activate the feature.

FAN SPEED REFERENCE

(Extreme 8000ti only)

Your fan speed will depend on thermal load on the wine cellar, and resulting cooling that is required to cool and maintain your wine cellar at the desired temperature.

Speed	CFM	DBA* Evaporator/Condenser	Cellar Capacity**
Low	274	57/57	1500 cu. ft.
Medium	318	59/59	1750 cu. ft.
High	333	60/61	2000 cu. ft.

* To get a feeling for decibels, a food blender at 3 ft. is 90 dBA, garbage disposal at 3 ft. 85 dBA, vacuum cleaner at 10 ft. is 75 dBA, normal speech at 3 ft. 79 dBA, dishwasher in the next room 55 dBA, Quiet night 35 dBA.

**Based on proper cellar construction and accounting for any windows or non insulated surfaces.
Please refer to the *Preparing the Wine Cellar* section on page 8 for more information.

INTRODUCTION

Customer Service

Thank you for purchasing a WhisperKOOL Extreme Series cooling unit. We strive to provide the highest quality products and the best possible customer service. If you have any questions about your WhisperKOOL unit, please call us at 1(800) 343-9463.

Using the Manual

This User's Manual is intended to assist in the proper installation and maintenance of the WhisperKOOL Extreme cooling system. In order to ensure the longevity of your cooling unit, the equipment should be installed properly and have a proper care and maintenance schedule. Please read and review this manual carefully and keep it for future reference.

What Is the WhisperKOOL Extreme Series Cooling System?

The WhisperKOOL Extreme Series system is a specialized refrigeration unit designed for one purpose only: to maintain the optimal temperature and humidity levels conducive to the proper storage and aging of fine wines. It is a self-contained cooling unit designed to be used as a forced-air through-the-wall unit or as a remote mount unit with external duct work connections.

How Does the WhisperKOOL Extreme Series Work?

The WhisperKOOL Extreme Series cooling system is especially designed for the use and application to maintain optimal conditions for wine storage and aging. The system is fully self-contained and can be installed as a "Thru-The-Wall" application, or the unit is capable of an even more flexible "Ducted" application, which allows the unit to be placed in an indoor remote site, resulting in a quiet airflow. Both models offer an alarm interface with your current alarm system, or an optional auto-dialer. You can also choose to have direct access to your control system via the Internet using a cell phone or computer, which will allow you to monitor the system, access data history, edit control parameters, and receive email/cell phone alarm notifications. The standard "Through-the-Wall" and ducted units are temperature controlled via a bottle probe, and the ducted system comes standard with a remote key board that can be located up to 300 ft from the cooling system (Note: Remote Unit comes standard with a 50 ft cord and remote keypad, additional lengths are optional).

Temperature Setting

The WhisperKOOL Extreme unit can be set at any temperature within the acceptable wine-aging range of 50°F to 67°F. It is designed to cool 55°F cooler than the ambient temperature of the space to which it is exhausting.

Model	4000	8000	8000ti
Cellar Size	1000 cu. ft.	2000 cu. ft.	up to 2000 cu. ft.
Dimensions	14.25"W x 15.75"H x 25.5"D	14.25"W x 22.5"H x 27.5"D	14.25"W x 22.5"H x 27.5"D
Weight	85 lb.	110 lb.	110 lb.
AMPS (starting/running)	32/9	36/10	00
dBA	67	66	57 low 59 med. 60 high
Installation	Through-the-Wall, partially ducted, fully ducted		
Thermostat	Digital Control Display		
Temp. Delta	55°F temperature differential (maintains proper cellar temperature when exhaust environment does not exceed 110°F)		
Outside Venting	Can be done if the outside temperature does not exceed 110°F, the external grille cover is highly recommended.		
Ducting Options	Unit can be fully ducted.		
Warranty	2 year parts and labor / 5 year compressor		

RECEIVING & INSPECTING THE UNIT

Customer Warranty Registration

PLEASE COMPLETE AND RETURN THE WARRANTY CARD UPON RECEIPT OF THE UNIT.

By completing the Product Registration Card, you will be confirmed in our customer database ensuring that your information is on file to help you obtain efficient warranty service.

Please refer to pages 34 - 36 for complete terms and conditions, warranty guidelines, and policy for your WhisperKOOL Extreme Series cooling unit.

Receiving and Inspecting the Unit

Note: WhisperKOOL Extreme units are manufactured in the USA and tested prior to shipment.

- Lift only at the designated hand hold locations on the shipping container or fully support the unit from underneath. A shipment may include one or more boxes containing accessories.
- Before opening the container, inspect the packaging for any obvious signs of damage or mishandling.
- Write any discrepancy or visual damage on the Bill of Lading before signing.
- Place the box containing the WhisperKOOL unit on a tabletop to prepare it for installation and testing.

Review the Packing Slip to Verify Contents

- Check the model number to ensure it is correct.
- Check that all factory options ordered are listed.

If any items listed on the packing slip do not match your order information, contact WhisperKOOL Customer Service immediately.

Check the Accessory Kits for the following contents:

Kit One:

- WhisperKOOL Extreme Series User's Manual
- Registration / Warranty Card

Kit Two:

- Power Cord
- Standard Screws (9)
- Self-Tapping Screws (9)
- Drain Line tube (1), Connection "T" (1), and Clamp (1)
- Mounting Flange Pieces (4)
- Bottle Temperature Probe (Standard Unit)
- Insulation Foam (4 strips)

Please leave the WhisperKOOL unit in its original box until you are ready for installation. This will allow you to move the product safely without damaging it. When you are ready to remove the product from the box, refer to page 13 for installation instructions.

Note: Save your box and all packaging materials. They provide the only safe means of transporting/shipping the unit.

PREPARING THE WINE CELLAR

The performance and life of your WhisperKOOL unit are contingent upon the steps you take in preparing the wine cellar.

Note: Improperly preparing your enclosure or incorrectly installing your WhisperKOOL unit may cause unit failure, leaking of condensation, and other negative side effects.

IT IS HIGHLY RECOMMENDED THAT YOU OBTAIN THE ASSISTANCE OF A WINE STORAGE PROFESSIONAL.

Wine storage professionals work with licensed contractors, refrigeration technicians, and racking companies to build well-insulated, beautiful, and protective wine cellars. WhisperKOOL has put together some useful tips to assist in the installation process. Our recommendations are meant to act as a guide in the process of building a proper enclosure. Your intended location may have specific needs that we do not address.

Wall & Ceiling Framing

Build wine cellar walls using standard 2x4 or 2x6 construction methods and ceiling joists following the guidelines of local and state codes in your area. As a general rule, the thicker the walls and the higher the insulation factor in your cellar, the better it will be at maintaining a consistent temperature.

Insulation

Insulation is REQUIRED with the use of the WhisperKOOL product. Standard fiberglass or rigid foam insulation is normally used in cellar construction or, in some cases, "blown-in" insulation is used. It is very important that all walls and ceilings are insulated to keep the cellar temperature as consistent as possible during the summer and winter months. The R-factor, or quality of insulation, is determined by the rate at which heat passes through the insulation. The higher the R-factor, the more resistant the insulation is to conducting heat. Using higher R-values in insulation will lower your operating costs and unit run time. (R-13 minimum, R19 recommended, R30 for ceiling and exterior walls)

Vapor Barrier

Vapor Barrier is REQUIRED to prevent the intrusion of water vapor so that the cellar can be kept at the correct temperature and humidity. 6 mm plastic sheeting (recommended) should be applied to the warm side of the cellar walls. The vapor barrier must also be applied to the outside walls and ceiling. If it is impossible to reach the outside, then the plastic must be applied from within the cellar. The most common method is to wrap the entire interior, leaving the plastic loose in the stud cavity so the insulation can be placed between each stud. All of the walls and ceiling must be wrapped in plastic for a complete vapor barrier.

In areas of high humidity, such as Southern and Gulf States, the vapor barrier will prevent infiltration of warm moist air. The moist air can cause mold to form, and standing water in drain pans promote microbial and fungal growth that cause unpleasant odors and indoor air quality problems. If mold is found, remove it immediately and sanitize that portion of the unit.

Mounting the Unit

The unit should be mounted within 18" of the top of the room in order to achieve sufficient cooling. As the room cools down, the warm air will rise to the ceiling. Mounting the WhisperKOOL high in the room will create a consistently cool environment by capturing the warm air and replacing it with cool air. Mounting the unit low in the room will result in a temperature variation in the room due to the unit's inability to draw warm air from the ceiling of the cellar to the unit itself.

Unobstructed Airflow

Unobstructed airflow to and from the unit is a critical factor in the unit's overall performance. Make sure there is a 3 ft. horizontal clearance in the front of the unit. This will assure that the unit can move the air around in an efficient manner. Avoid any attempt to camouflage the unit by installing racking in front of the unit. This will restrict the airflow and lower the performance of the unit.

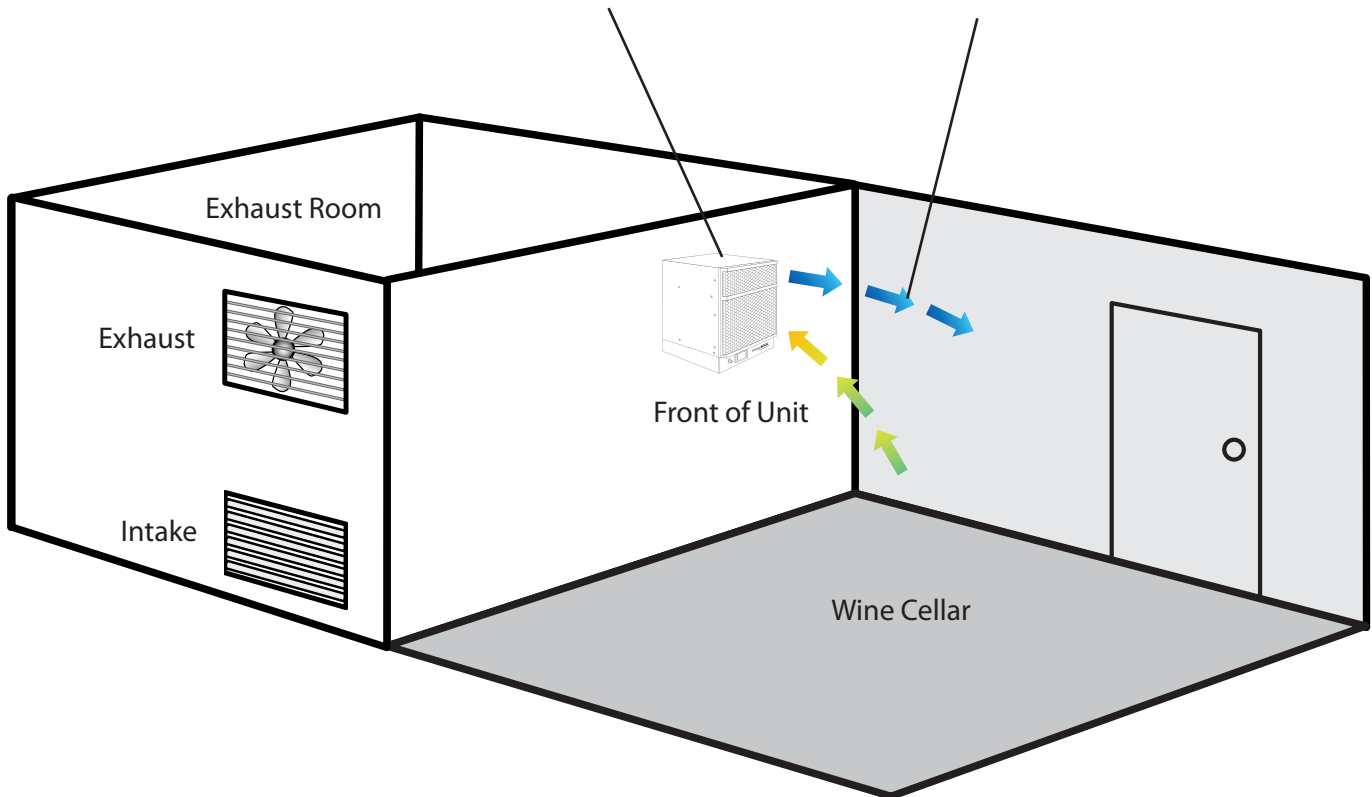

Door and Door Seal

An exterior grade (1 3/4") door must be installed as a cellar door. It is very important that weather stripping is attached to all 4 sides of the door jam. A bottom "sweep" or threshold is also required. The door must have a very good seal to keep the cool cellar air from escaping out of the cellar. One of the most common problems with cooling units running continually is the door not sealing properly. In cases where glass doors are used and the room size is close to the recommended unit size, the next larger size WhisperKOOL should be used. This will compensate for the insulation loss due to the inefficient door.

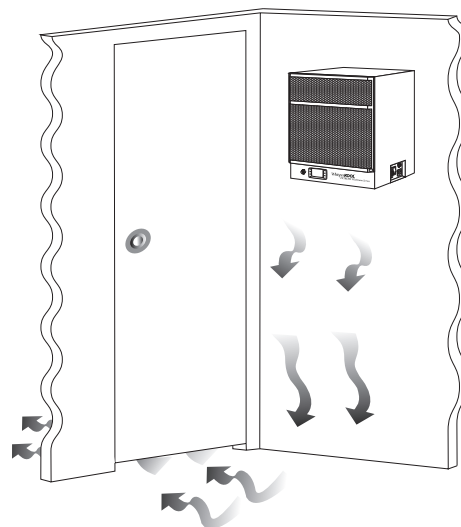

Ventilation

The necessity of dissipating heat away from the unit is critical to the unit's performance and cannot be overstated. As the unit operates and cools, a greater amount of heat is generated on the exhaust side of the unit. Adequate ventilation is required in order to dissipate heat away from the unit. If ventilation is inadequate, the exhaust will heat up and adversely affect the unit's ability to cool. In some cases, it may be advisable to install a vent fan to dissipate heat within the exhaust area on the backside of the unit. However, you must have a fresh air inlet as well. If your unit requires ducting, please contact WhisperKOOL Customer Service to obtain a specially designed ducting accessory kit for the unit. Using any other ducting system will void the warranty.

Ambient Temperature Factor

The cooling system has the ability to cool a maximum of 55°F below the ambient temperature of the room it is exhausting to. Therefore, you want to exhaust the unit in a room which will not exceed 105°F. Otherwise the unit will not have the capacity to keep the wine at a desirable 55°F.

Unobstructed Airflow

Unobstructed airflow to and from the unit is a critical factor in the unit's overall performance. Make sure there is a minimum 3 ft. horizontal clearance from the rear of the unit as well as a minimum 3 ft. clearance in front of the evaporator fans. This will assure that the unit can move the air around in an efficient manner.

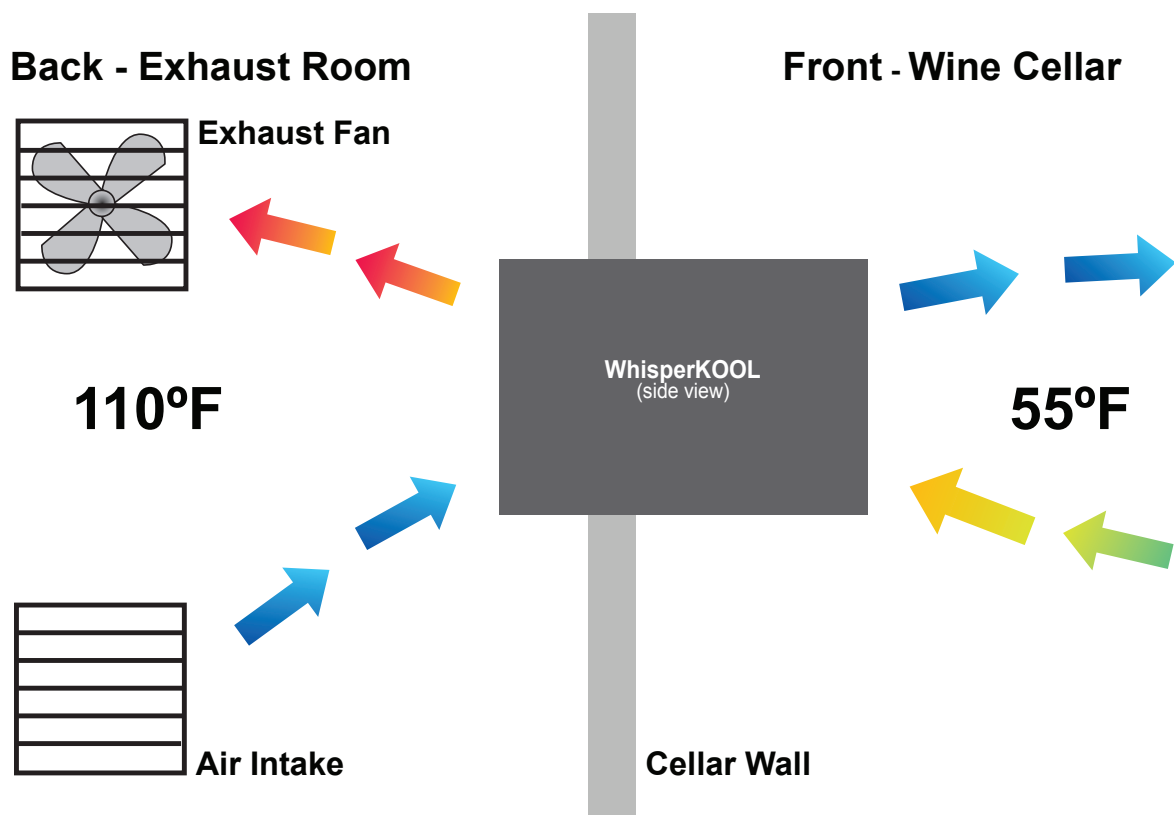

How to Build a Wine Cellar Instructional Video

WhisperKOOL has a construction tutorial available on line at our website: www.whisperkool.com. This tutorial will walk you through the steps of constructing a properly built wine cellar and the installation of our WhisperKOOL product line.

Sizing the Unit to the Room

Model	Cellar Volume (cubic feet)	AMP's (starting)	AMP's (running)	Product Dimensions (W x H x D)
4000	1000	32	9	14.25" x 15.75" x 25.5"
8000	2000	36	10	14.25" x 22" x 27"
8000ti	2000 high	36	10	14.25" x 22" x 27"
8000ti	1750 med	36	10	14.25" x 22" x 27"
8000ti	1500 low	36	10	14.25" x 22" x 27"

Cutting the Hole for the WhisperKOOL Unit

Tools Needed

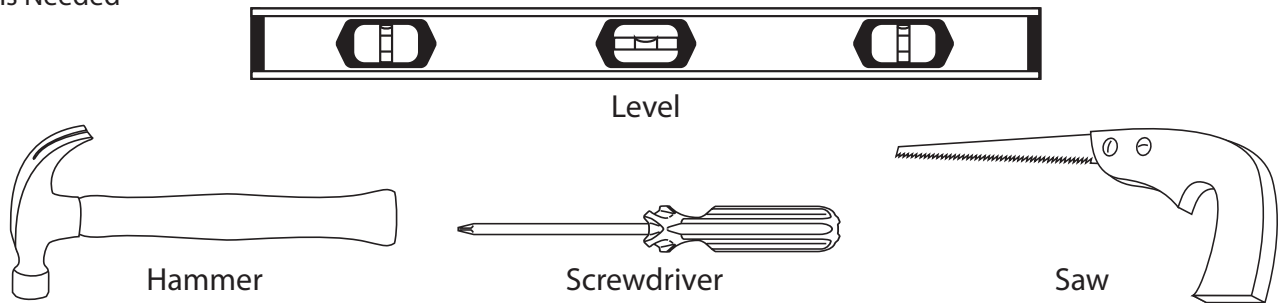

Locate the center of the wall upon which the unit will be installed. Using a stud finder, locate the studs on either side of the center point, and mark them with vertical lines.

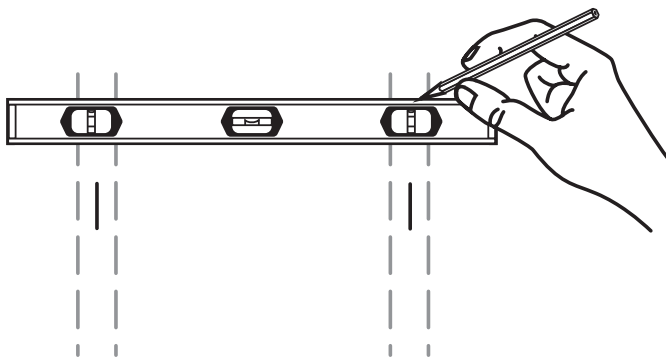

Mark the horizontal lines with a level

Using a level and a pencil, mark a horizontal line on the wall between the two studs, approximately 1.25" (or as close as possible if more than 1.25") from the ceiling.

Using a ruler or measuring tape, measure 16" down, and mark another horizontal line parallel to the first one.

Using a saw, cut along the uppermost horizontal line until your saw reaches the stud. Turn the saw around, inserting it into the cut you have just made, and cut toward the opposite stud so that you have a clean horizontal cut between the two studs. Be careful not to cut into the studs themselves.

Now make the second horizontal cut from stud to stud on the line 16" below the first cut.

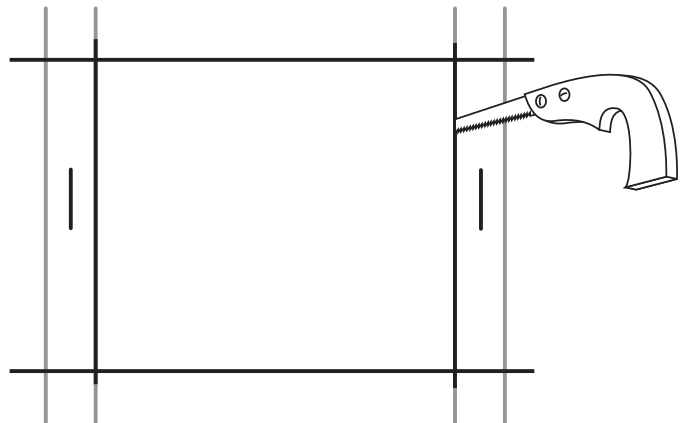

Once the horizontal lines have been cut, make vertical cuts using the inside edge of the studs as a guide. Once you have made both vertical cuts, you should have a rectangular hole in the sheetrock. Now you have to make the same hole on the other side of the wall. Since you already have one hole, this is an easy process. Using a nail, mark all four corners of the first hole by making nail holes through the sheetrock. Then on the other side of the wall, connect the holes with a pencil mark and cut.

Sheetrock alone cannot support the weight of a 65 lb. (or more) cooling system. Therefore, it is necessary to frame the hole that you have just cut with upper and lower supports.

Using two 2x4's at 14.5" in length and eight 6d nails, secure the upper and lower supports to the right and left studs, just inside the sheetrock. Make sure that the internal height remains at 16" so that the WhisperKOOL system will fit snugly through the framed cut-out.

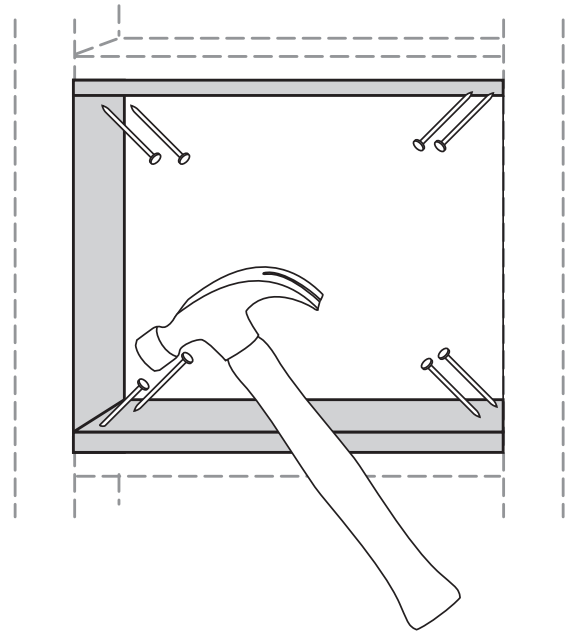

Frame the hole with two-by-four supports

INSTALLATION

Electrical Needs

The WhisperKOOL Extreme System requires a dedicated 115-volt 15-amp circuit. The unit draws a large amount of amps at initial start up. By designating a dedicated circuit breaker, you will guarantee the unit has enough power to run effectively. Contact an electrician for assistance with the installation of this dedicated electrical circuit:

1. Match the electrical outlet to the plug provided on the WhisperKOOL unit.
2. Provide a dedicated circuit and wiring for the unit.
3. Provide a weatherproof plug for units mounted outside.
4. Mount outside units at a height of 18" and provide overhead protection.

Electrical Outlet

The unit is equipped with two electrical outlets: one for the interior or cellar side and one for the exterior or outside of the cellar. There is a toggle switch located on the right side of the unit that indicates front (cellar side) and rear (exterior side). When placed in either position, power will come from that outlet only.

Plug your WhisperKOOL unit into a surge protector or power conditioner. As with any sensitive electrical equipment, the WhisperKOOL electrical equipment may be damaged by power surges and spikes. Power surges and spikes are not covered in the WhisperKOOL Extreme warranty.

WE RECOMMEND THAT YOU DO NOT USE A GROUND FAULT INTERRUPTER (GFI) WITH THIS PRODUCT.

In case the unit should lose power, press the reset button and attempt to turn the unit back on. Check the home/main circuit breaker. If the unit does not respond properly, refer to the Troubleshooting section on page 31.

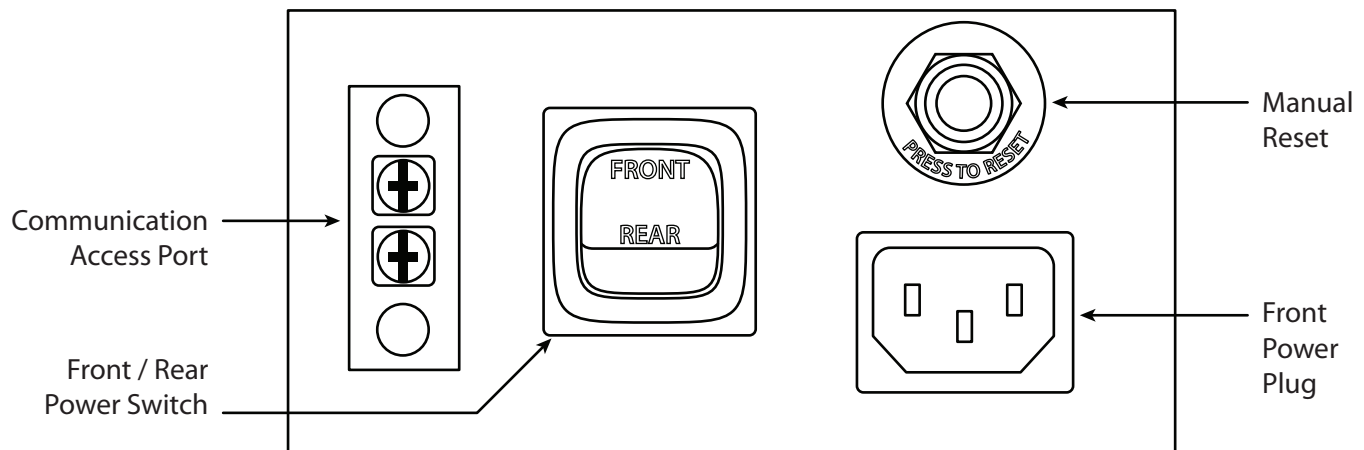

Test the Unit Prior to Installation

To prepare it for testing before installation in wall:

- Remove unit from box
- Place unit on tabletop
- Plug in unit to electrical outlet
- Plug in bottle sensor
- Turn on to test (Should be 12°F across coils)
- Turn off after test
- Remove bottle sensor

THROUGH-THE-WALL INSTALLATION (without ductwork)

Mounting Flange Pieces

There are four individual pieces located in Kit 2 of your enclosed accessory kits. These flange pieces are designed to be used on the backside of the Extreme Series to mount to the exterior wall. There are three punch-outs located on the exterior of the housing. The punch-outs are designed for specific through-the-wall installation mounts. Please refer to the illustration for location of the punch-outs.

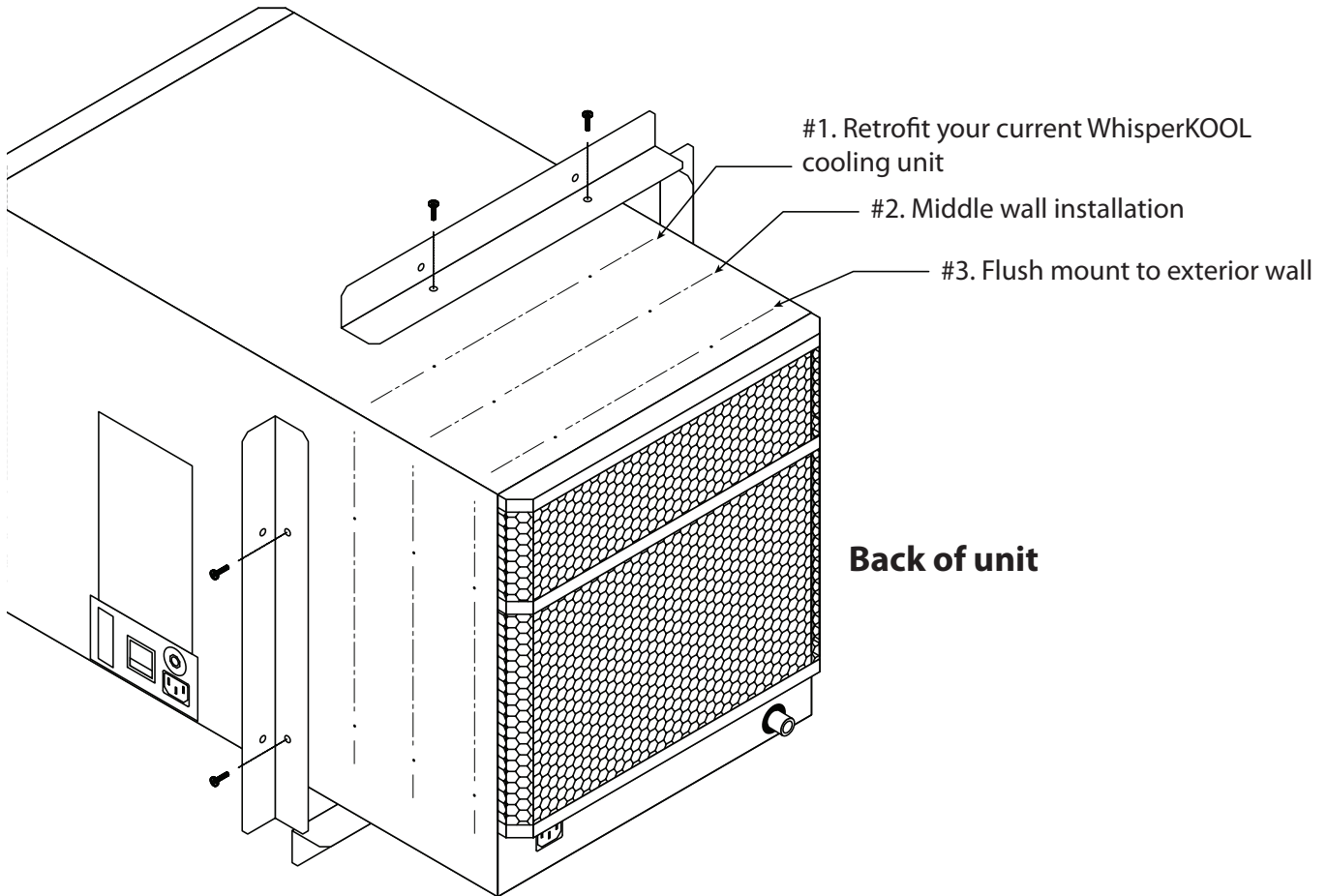

Applying Insulation Tape

Locate the four precut pieces of black foam tape included with the system. There should be two larger pieces and two smaller pieces. Once you have attached the flange pieces to the unit, peel back the white-paper adhesive covering and place on the corresponding size of flange. The large pieces are applied to the top and bottom of the unit and the smaller pieces to the right and left side flanges. This foam creates a tight seal between the flange and the wall.

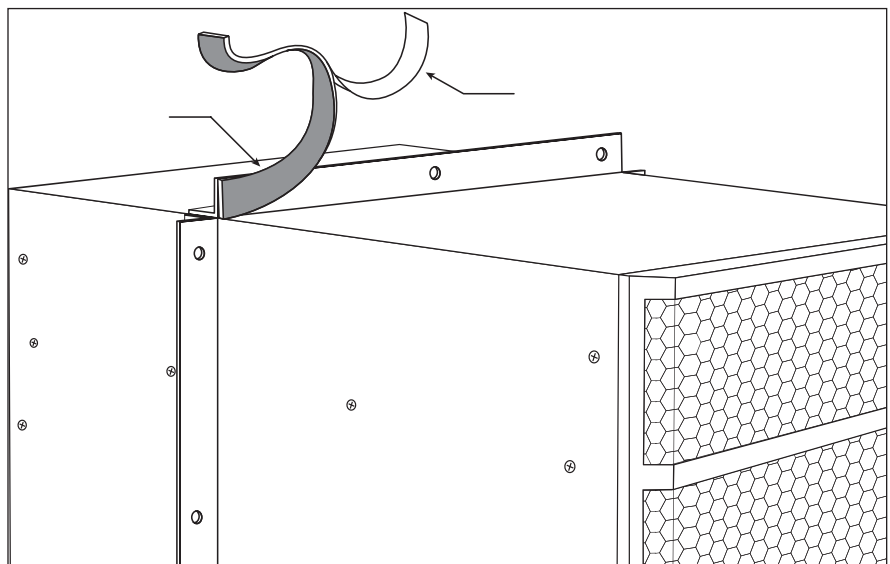

Placement of Unit

Slide the unit from either the inside or outside wall into your wine cellar with the outer flange flush to the wall. You will need to reverse the mounting flange depending on inside or outside use. Secure the flange to the wall through the pre-drilled holes. The screws should penetrate the studs as well as the upper and lower supports to provide adequate support for the WhisperKOOL system (see illustration). Seal all cracks and gaps around the WhisperKOOL Extreme unit with an air-tight sealant or caulking to prevent air leakage.

Note: If you use decorative molding, it should be attached to the walls and never to the cooling unit itself.

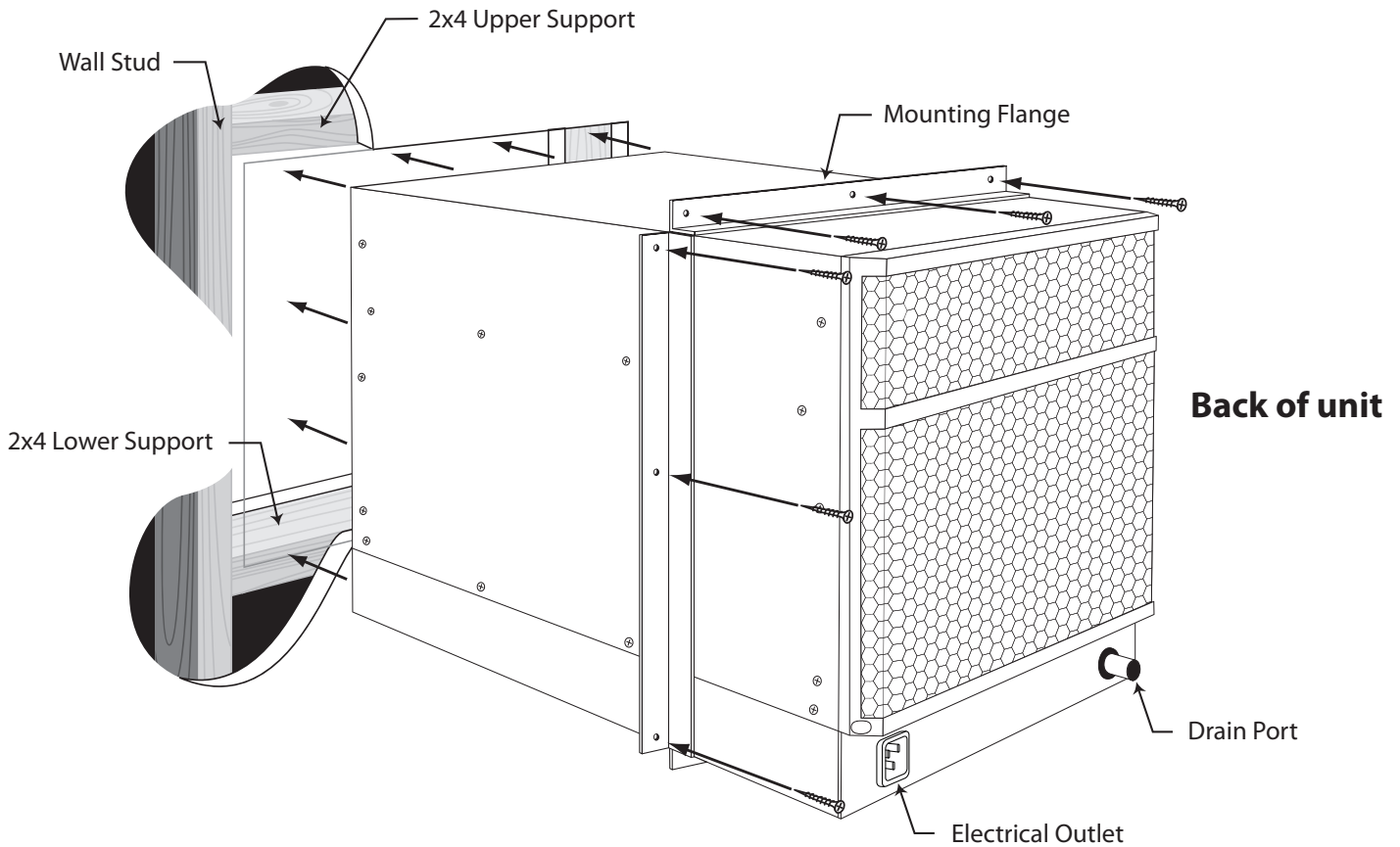

Location of Supply and Return Grilles

Locate the supply and return grilles inside the cellar to create an airflow pattern that maximizes air circulation in the room. Avoid short circulation of the air.

Do not:

- Install through-the-wall return air grilles at floor level, as they will collect dust from the floor.
- Mount the unit lower than 18" from the top of the room.
- Locate the supply or return air grille where it is blocked by bottles, boxes or cases.

Condensation Drain Line Tube

The condensation drain line tube is used to remove excess condensation from the unit to a proper discharge location. It is important that the drain line tube is properly connected and used to prevent leakage and other problems associated with excess condensation.

Failure to use the condensation drain line tube will void the warranty on the unit.

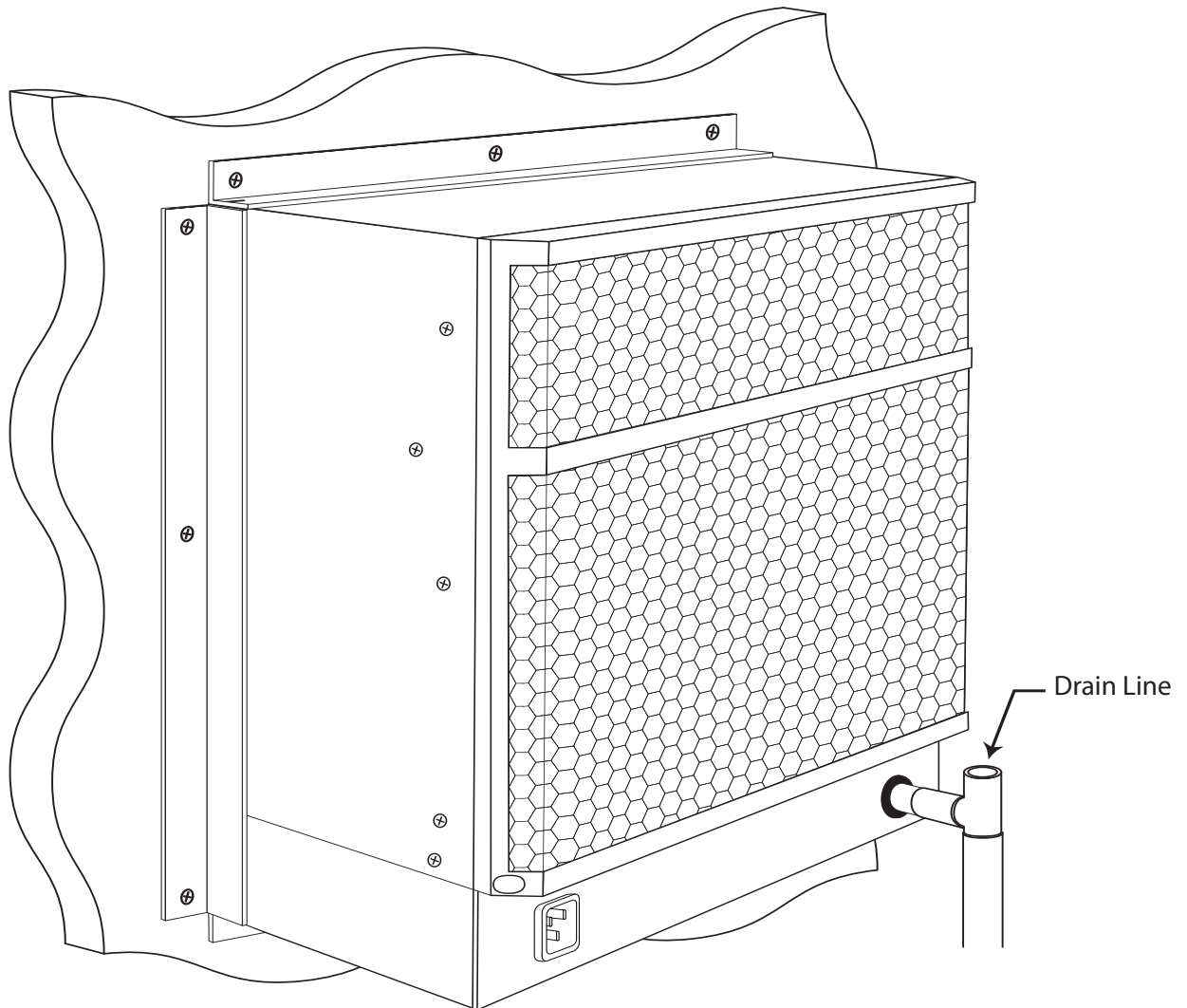

INSTALLATION OPTIONS

Exterior Grille Installation

The exterior grille is required on all installations where the condenser side of the unit is exposed to the outside of the dwelling (i.e. rain and weather).

The condenser grille must be removed. Locate the screws at the bottom of the grille and remove. Using medium force, push the grille upward and lift the grille away from the unit. Replace the bottom screws and tighten the upper screws.

Now determine at what depth the unit will be installed:

- For a non-flush installation (i.e. holes location #1 WhisperKOOL retrofit or #2 Middle Wall), place the grille on the condenser end and line up the holes on the grille with the holes on unit location #3. Use the 10 screws provided to fasten the grille to the unit.
- For a flush installation, place the grille on the condenser side and then place the mounting bracket over the grille sides, "stacking" them. Align the holes and fasten with the 10 screws provided.

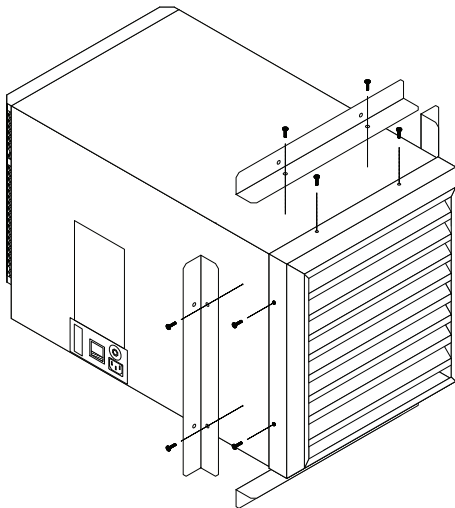

Non-Flush Installation

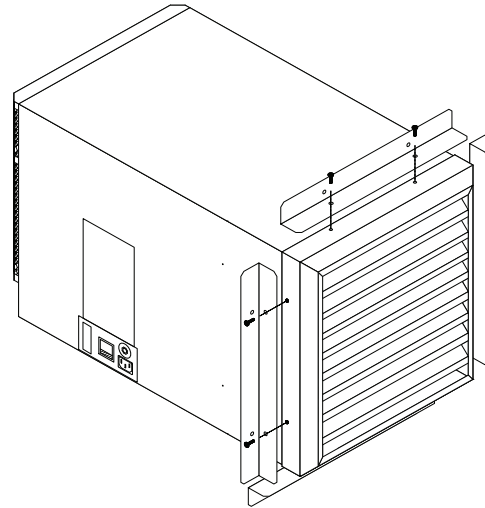

Flush Installation

DUCTED INSTALLATION

Use duct work to connect the unit to the supply and return outlets in the wine cellar. Use only insulated duct work to minimize cooling losses, prevent sweating, and reduce noise.

Use duct work on the condenser section to redirect or absorb sound, bring in outside air to the unit inlet, and/or exhaust the hot air.

Note: Do not exceed a total of 25' for each length of duct work run and a total of 50' combined for both the supply and return lengths.

Avoid crimping the flexible ducts. This chokes down the inside area and reduces the airflow causing the unit to operate erratically.

Be sure all ducts and surfaces in contact with the airflow are insulated and have a vapor barrier on the outside.

Un-insulated ducts and surfaces cause bare, exposed metal surfaces to sweat, further degrading the insulation and equipment cooling capacity.

General Duct Recommendations

- Provide support for the flexible duct to prevent sags and bends.
- Stretch out the duct to make a smoother interior, which reduces air resistance.
- For 90° bends, use a 90° adjustable elbow (EII).
- Do not squeeze or reduce the inside diameter of the ducts, which reduces airflow.
- Use short and straight duct work where possible.
- Remove the grilles and panels from the openings to connect the duct work.
- Check that all fan blades move freely.
- Keep air paths free of loose foreign objects and debris.
- Connect the round flexible ducts to the WhisperKOOL unit using the duct collars provided with the duct accessory kit.
- Pull the outer plastic wrapping and insulation away from the end of the duct to expose the reinforced inside duct liner.
- Fasten the duct collar using tie straps or clamps around the inside liner.
- Secure the duct collar to the unit using the screws provided. Take care to not damage or bend the gasket.
- Use approved duct tape to seal all joints.

Do not clamp around the outside insulation, as it will compress and loosen over time.

Cold Air to/from Wine Cellar

- Remove the supply air grille to install duct work between WhisperKOOL unit and the cellar.
- Connect the supply air duct work from the cellar to the supply air outlet adapter flange at the WhisperKOOL unit.
- Connect the return air duct work from the cellar to the return air inlet adapter flange at the WhisperKOOL unit.

Warm Air to/from Wine Cellar

- Connect duct work on the condenser to direct heat and air noise away from occupants.
- Connect duct work to another space within the basement or out of the building if exhausted heat is undesirable.

DUCTED INSTALLATION cont.

STEP 1:

Remove the grill from the unit by unscrewing the screws that hold it in place.

STEP 2:

Move the duct plenum into place

STEP 3:

Screw the plenum into place using the same screws that held the grill in place.

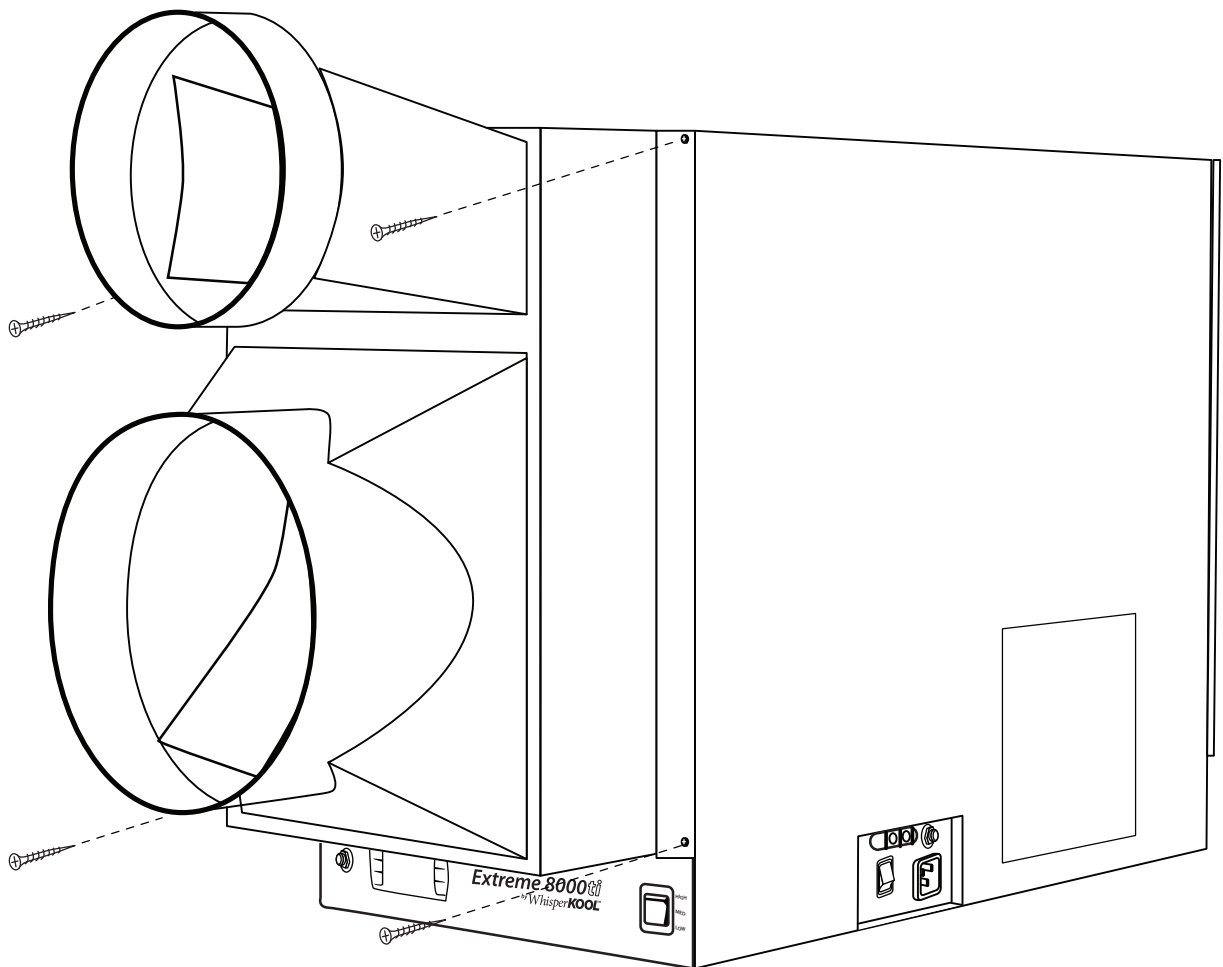
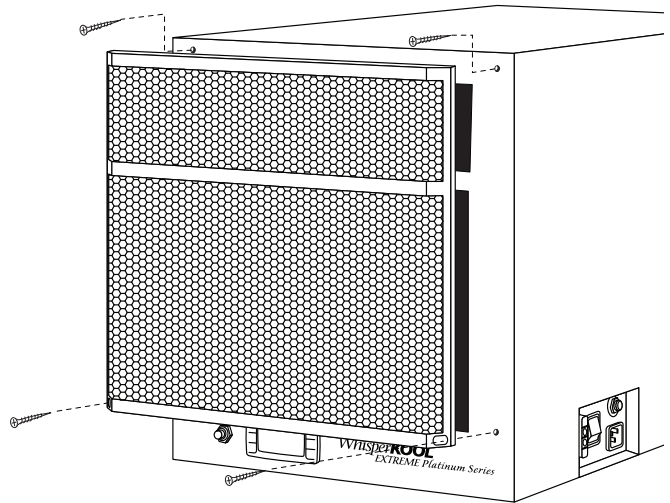

STANDARD DUCTED INSTALLATION

Dual Outlet Duct

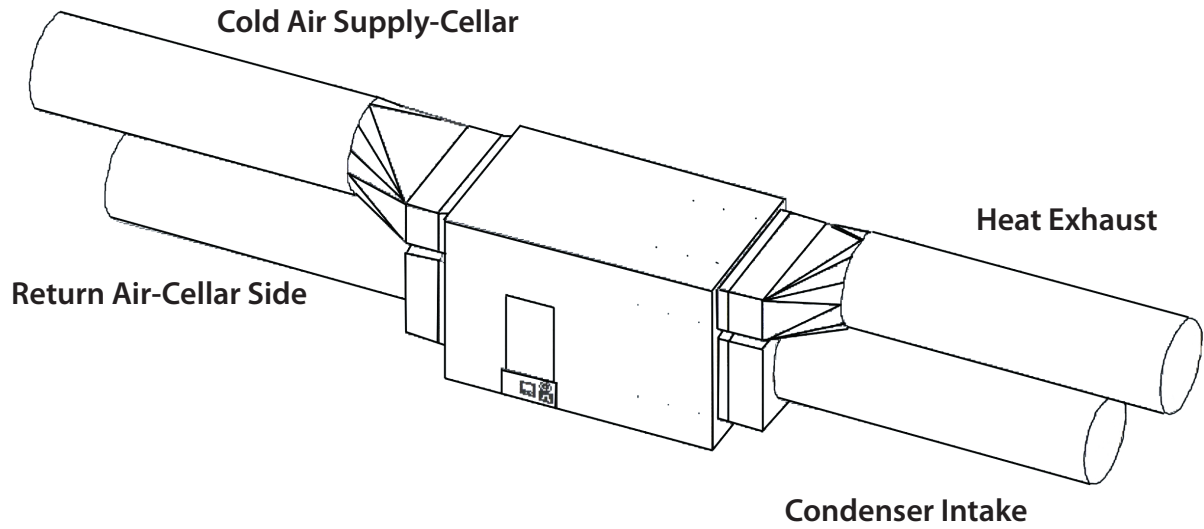

Attic Mounted System

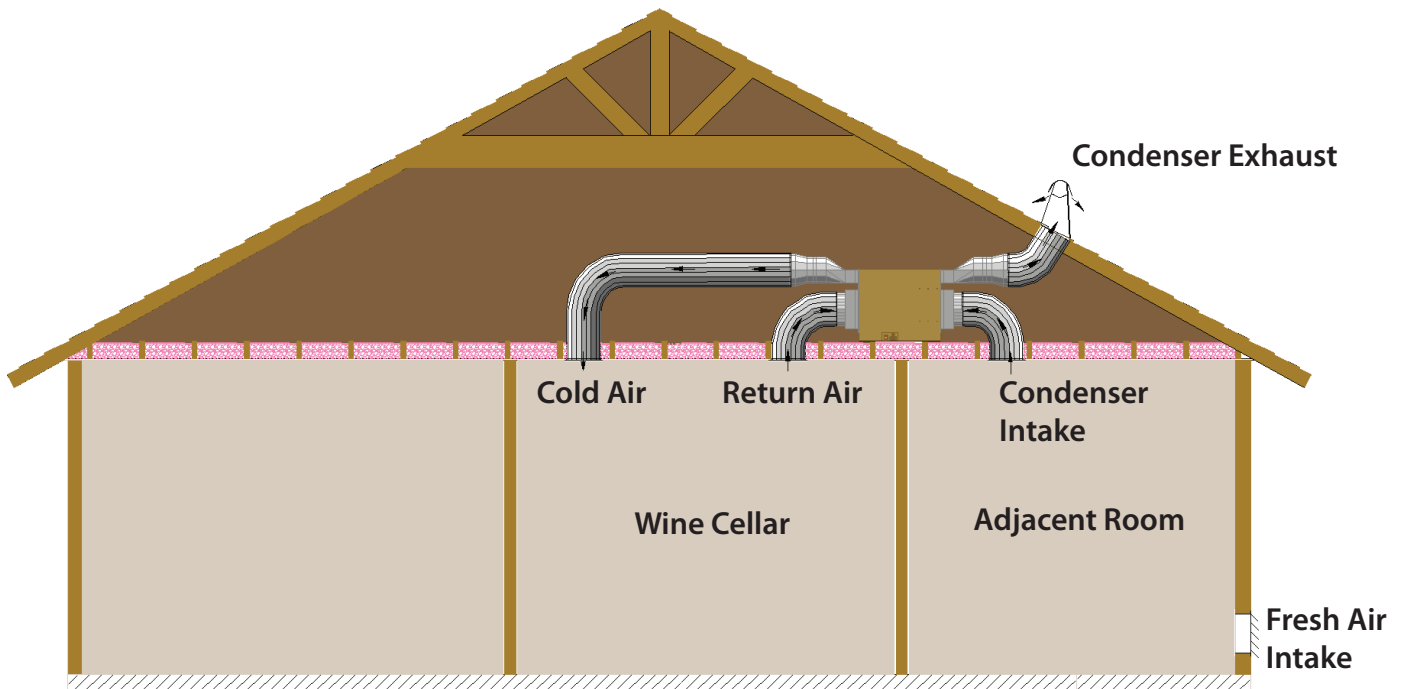

STANDARD DUCTED INSTALLATION

Dual Outlet Duct

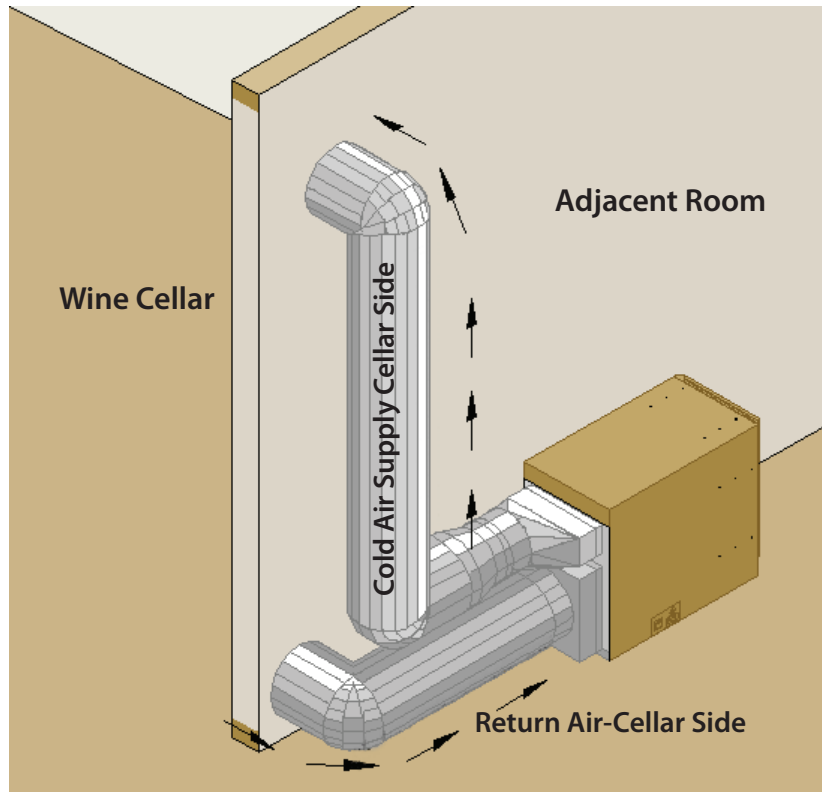

Outside through the Wall

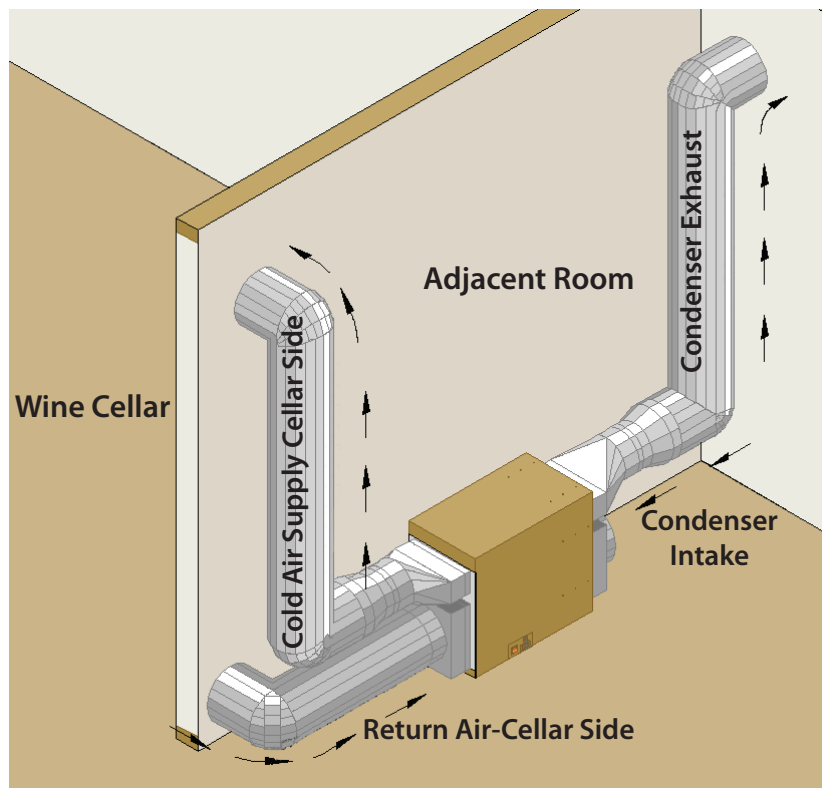

REMOTE CONTROLLER: INSTALLATION AND CONFIGURATION

The WhisperKOOL Extreme Series can be configured with a remote controller system. If you have a unit with a remote controller, please review this section.

The controller can be installed up to 50 feet away from the cooling unit, or up to 300 feet away with the extended connection wire.

To install the remote controller, remove the mounting bracket and secure the bracket to the wall in the desired location. Reattach the controller to the bracket.

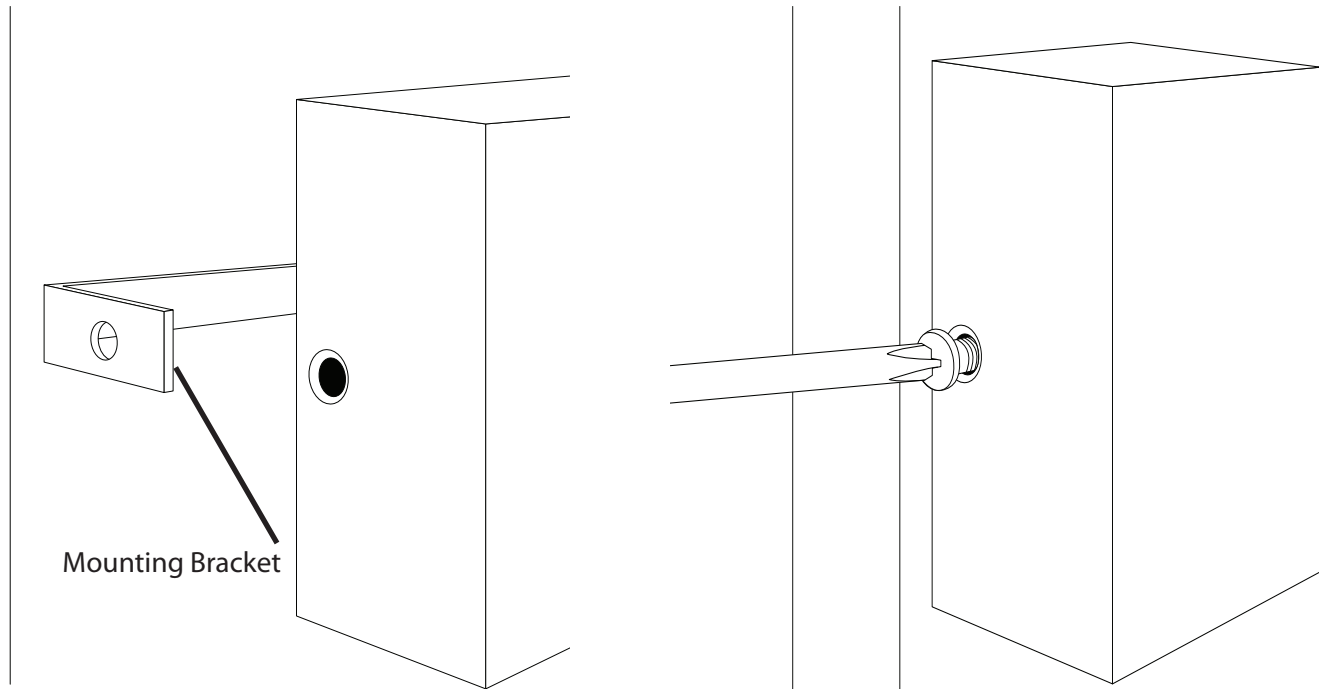

Attach the connection wire as shown below, with the red wire in the upper connection slot and the black wire in the lower slot.

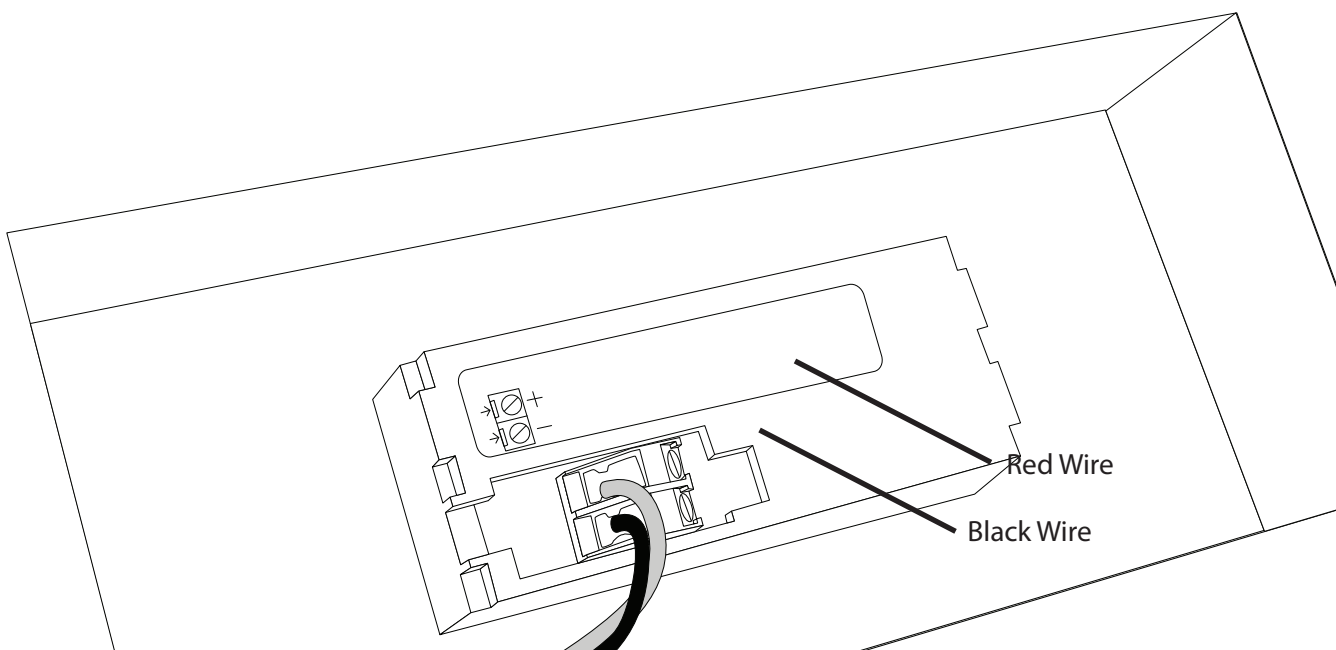

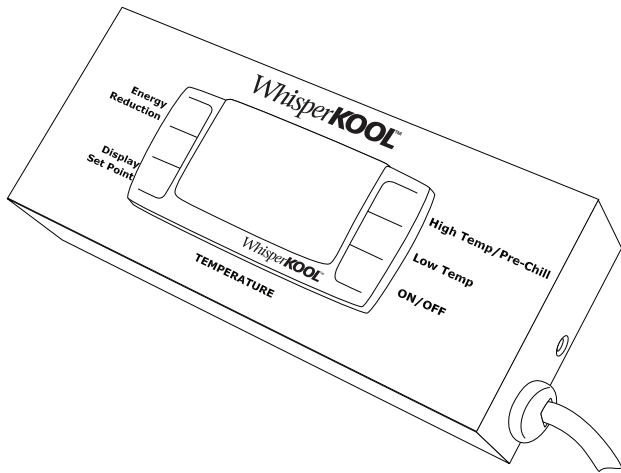

Connection wire in Side Mount configuration

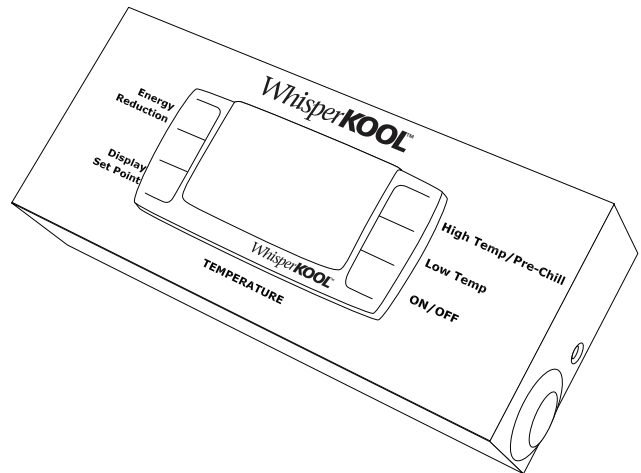

Connection wire in Rear Mount configuration

Below is an illustration of one possible way to configure the remote controller in a wine cellar.

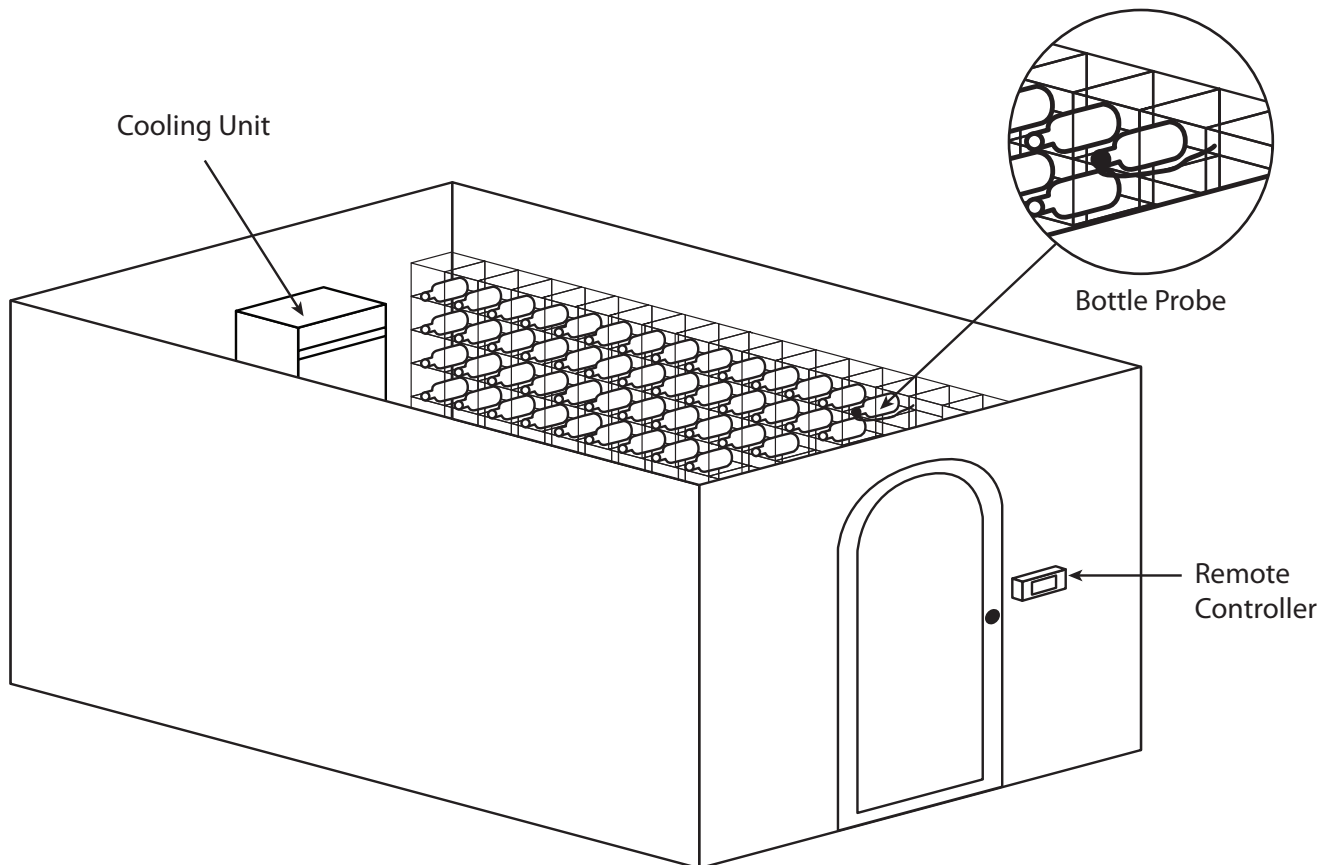

LIQUID MEASURING THERMOSTAT SYSTEM

The WhisperKOOL Series cooling units come equipped with a liquid temperature measuring thermostat system. This system incorporates the following advantages:

1. **Self-Calibrating Probe:** The probe contains a sensor chip, which actually communicates back and forth to the thermostat. This results in a consistent temperature setting and accuracy. Do not remove the tip from the probe!
2. **Heavy-duty Circuitry:** The circuitry within this new unit has been upgraded to resist power surges, which play havoc on electrical components. This improvement will ensure years of trouble-free use. However, for the highest reliability, we recommend that the customer install a surge protector for the unit itself.

Measuring liquid temperature has a few unique advantages:

1. Wine temperature is kept in a very precise controlled environment. This assures a consistent temperature.
2. By measuring the liquid temperature rather than air, the unit will operate 75- 80% of the time.

To Use the thermostat:

1. Locate an empty wine bottle.
2. Fill 3/4 full with room temperature tap water.
3. Place bottle probe securely into bottle.
4. Place bottle with probe level and to the side of the unit in your wine cellar. Avoid pulling too much on the probe cord. It may become disconnected resulting in non-operation of the unit.

Note: The thermostat can be set between 50°F and 76°F.

Remember: The WhisperKOOL System is based on the temperature of the water.

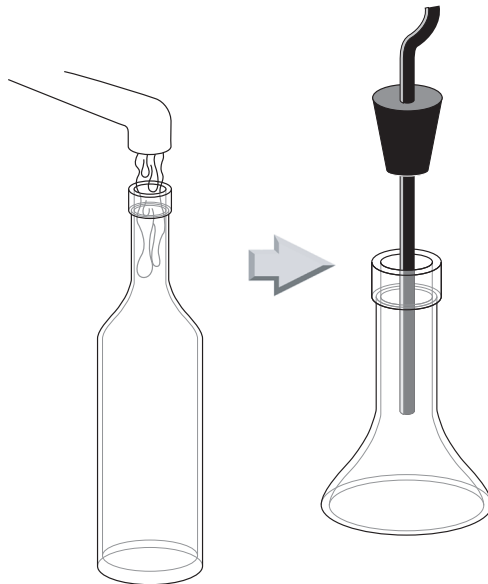

VARIABLE SPEED CONTROL

(only on the 8000ti)

Designed for wine cellars from 1500 to 2000 cubic feet, the Extreme 8000ti features variable-speed fans with a “high” setting for maximum performance in high-temperature (+110°F) environments and a “low” setting for super-quiet operation.

Fan Speed Selector Switch (Low/Med/High): The cooling unit fans operate on 3 speed settings: Low, Medium, and High. For optimum sound and energy efficiency, select the lowest fan speed that will maintain the desired cellar temperature. High speed is recommended for initial cellar cool down, extreme temperature conditions and ducted installations.

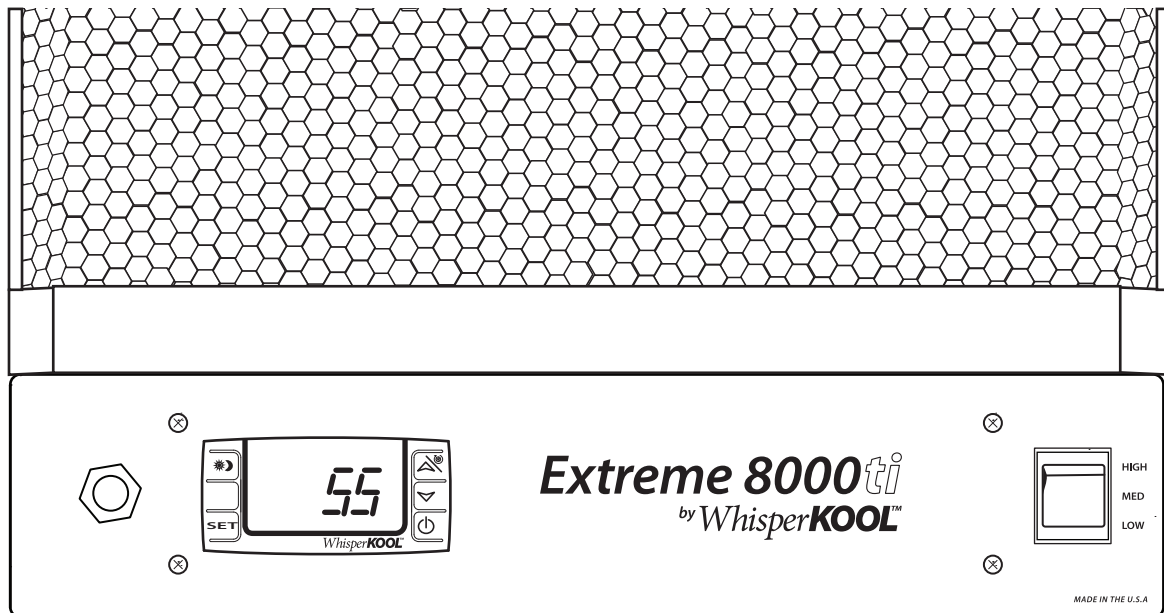

SYSTEM OPERATION: STANDARD & REMOTE

Initial Start-Up

When power is applied to the unit, the control will briefly display all symbols, and the Compressor symbol will be displayed (if unit is calling for cooling). There may be a brief delay prior to the evaporator and condenser fans turning on, as the fans will not turn on until the sensors reach their perspective start temperatures (below 70°F for the evaporator and above 80°F for the condenser). When the condenser fan is activated the "AUX" symbol will turn off, and when the evaporator fan is activated the "FAN" symbol will turn on. The temperature control feature for the evaporator fan is a feature applicable to Whisperkool Advance Product Safety Technology (APST), which ensures that in the possible event of a cooling deficiency, the heat from the indoor fan will not raise the heat of the wine cellar, which could otherwise have an adverse effect on the wine aging process. After the indoor coil reaches a temperature below 70°F, the indoor fan symbol will be displayed and the fan will turn on.

Note: For remote system condenser fan cycles with the compressor, the "Aux" symbol does not apply.

Normal System Cycle

After the bottle probe has reached the set point (all units are shipped with the set point of 55°F and a differential of 1°F), the compressor and the condenser fan will turn off, but the indoor fan will continue to run for about 5 minutes, which is a feature of the WhisperKOOL Humidity Management (WHM) system. The WHM is an adjustable feature which allows the customer the convenience of managing the humidity enhancement of their wine cellar. The WHM is one of the many Customer Preference Selection features which allow the customer the ability to fine tune the controls.

Anti Short Cycle

The Anti Short Cycle ensures that the unit will remain off for a period of 5 minutes after the unit has reached the set point to allow the pressure in the refrigeration system to equalize prior to starting the compressor.

Defrost Cycle

The Defrost Cycle is a precautionary measure, as icing or frosting of the coil does not occur during normal operation. The system will go through a defrost cycle every 4 hours. During the defrost cycle, the indoor fan will provide air flow across the indoor coil, which will evaporate any frost accumulation.

Low Ambient Conditions

If the unit is installed in a Through-The-Wall application (which will allow the condenser to be exposed to low ambient temperatures), the condenser fan may cycle on and off. The purpose of the fan cycling is to maintain the system high side pressure, which will ensure an adequate refrigeration process. The fan cycling process is accomplished by way of a temperature probe attached to the condenser coil.

Note: Remote control systems do not use condenser fan cycling.

Bottle Probe Failure Protection

In the event that a bottle probe should fail, the APST (Advance Product Safety Technology) will automatically transition the Refrigeration Compressor cycles to a pre-determined time series (based on detailed laboratory testing), which will ensure that the product is kept within the safe range.

Remote Control Panel (optional)

The control panel can be installed or mounted separately from the cooling unit itself (remotely), using the supplied cable. This option provides unique flexibility for installing the Extreme Series cooling unit in your wine cellar. The remote option must be specified when the unit is ordered.

Note: Remote Control is generally standard with a "Ducted Unit"

Ducting and Ventilation Options

The ventilation system is ideal for ducting. The optional collars fit standard ventilation ducting allowing the installer to vent air to and from the unit for optimum performance (please see specifications for details).

CONTROL PANEL FEATURES AND OPERATION

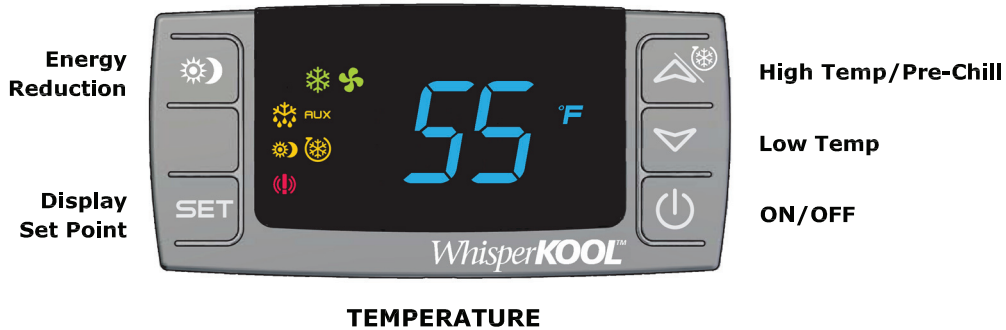

TEMPERATURE

Button	Normal Functions
ON/OFF	<ul style="list-style-type: none"> The ON/OFF button allows the customer the convenience of turning the refrigeration system ON or OFF, from the control panel. This feature does not disconnect power from the unit, and the condenser fan will continue to run in the OFF position. In order for the power to be shut off from the unit, the power cord must be unplugged from the wall receptacle. Press the ON/OFF button once for button application.
Up and Down Arrows	<ul style="list-style-type: none"> Use these buttons to scroll up or down the CPSM menu. Displays the Highest and Lowest temperature sensed by the Bottle Probe. This feature allows the customer instant access to the recorded data applicable to the Bottle Probe Temperatures, it can be easily reset to reflect current temperatures. <ol style="list-style-type: none"> Press the "UP" arrow, or the "Down" arrow once, and the Highest or Lowest Temperature (Hi/Lo) sensed by the Bottle Probe, will be displayed. To reset the Hi/Lo, press and hold the "Set" button when the Hi/Lo value is displayed on the Digital Display, continue to hold the "Set" button until "rst" appears on the digital display and then blinks. This will erase the past recorded "Temperature Data History" and start recording, from the current time and temperature, forward. Temperatures displayed would reflect Bottle Probe Temperatures from that point in time, and beyond. The Hi/Lo feature should be reset at initial "Start-Up" and after the Cellar or Cabinet has obtained normal operating temperatures, which is generally 55°F.
Cellar PreChill (CPC)	<p>The CPC Feature is activated by pressing the Up button for 3-5 seconds, and the CPC logo will be displayed on the digital display. The CPC feature can be terminated by pressing the Up button for 3-5 seconds, or the feature will self terminate after 6 hrs.</p> <ol style="list-style-type: none"> The (CPC) Feature may be used to Pre-Chill the Cellar prior to loading it with Warm Product. The feature will shift the Set Point down to a lower setting of 52°F, for the next 6 hours. After the 6 hour time period, the Set Point will automatically return to the original Set Point. The CPC feature can be conveniently adjusted to the customer's specific needs, by accessing the "Customer Preference Select Mode" (CPSM). See Customer Preference Select Mode Instructions. <p>Note: This feature is not available on the Remote Key Pad application.</p>

Energy Reduction (ER)	<ol style="list-style-type: none"> 1. The ER feature can be used to save energy and aids in extending the life of the system. 2. The ER button is located at the top L/H side of the control. The ER feature is activated by pressing the ER button one time, and the ER logo will appear on the digital display. 3. The purpose of the ER feature is to reduce energy cost, by shifting the Set Point up by 4 degrees, which will allow the cooling system to run for shorter periods of time, resulting in a reduction in energy cost. 4. The ER feature allows for Energy Savings at any time - During periods of high ambient temperatures, vacations or business travel. 5. To deactivate the ER feature, press the ER button one time, and the ER logo will turn off. 6. The ER feature can be conveniently adjusted to the customer's specific needs, by accessing the "Customer Preference Select Mode" (CPSM). See Customer Preference Select Mode Instructions. <p>Note: This feature is not available on the Remote Key Pad application.</p>
Set Button	<ol style="list-style-type: none"> 1. Press the "Set" button once and it will display the Set Point. After approximately 5 seconds, the display will return to normal operation and display the Bottle Probe temperature. 2. Press and hold the "Set" button for 3-5 seconds until the set point is displayed and the °F symbol starts blinking. Next press the "UP or Down" arrows to change the Set Point. Next press the "Set" button once and the Set Point numbers and the °F on the display will blink to confirm the new Set Point setting. 3. Press and hold the "Set" button during the display of the Hi/Low "Temperature Data History" (hold button unit "rst" blinks on display), and it will erase the past recorded data file and start recording, from the current time and temperature. 4. Press the "Set" and the "Down Arrow" buttons simultaneously, for 3-5 seconds, and you will access the "Customer Preference Selection Mode" (CPSM). The CPSM allows the customer to "Fine Tune" the Control Operating System to their applicable choice.
CPSM Mode	<p>Press the "Set" and the "Down Arrow" buttons simultaneously, for 3-5 seconds, and you will access the "Customer Preference Selection Mode" (CPSM). The CPSM allows the customer to "Fine Tune" the Control Operating System to their applicable choice.</p> <p>The following CPSM options are available for adjustment:</p> <p>Fon – Humidity Management Enhancement: This parameter is normally set at 5, which should provide adequate relative humidity for the cellar.</p> <ul style="list-style-type: none"> • An increase in this parameter will increase the Humidity Enhancement (%RH), and a decrease in the parameter will decrease Humidity Enhancement (%RH). • Adjustments should be made in increments of 5, with a maximum of 15, and a minimum of 0. • After any adjustment to Humidity Enhancement, you should wait a minimum of three days before making any additional adjustments. This will allow the cellar sufficient time to acclimate to the new setting. <p>Fof - Humidity Management Enhancement: This parameter is normally set at 1. This parameter should not be adjusted, as it simply provides an OFF cycle time for the fan, during the compressor OFF cycle. However, the parameter is located within the CPSM as a convenience to the customer, should it need to be adjusted.</p>

CPSM Mode (Cont.)	<p>CCS – Cellar Pre-Chill Set Point: This parameter is set at 52°F, but can be adjusted to a set point between 45°F - 67°F.</p> <p>bLL/Act – Compressor Off or On for Low (bLL) or High (Act) Temperature Alarm: These parameters are set at “n”. With this parameter set at “n” the refrigeration system will continue to operate normally, if there is a High or Low temperature Alarm. To change this parameter, change the setting to “y”, and the compressor/refrigeration system will shut off during a High or Low temperature Alarm.</p> <p>Con/Cof – Compressor On time (Con) and Off time (Cof) with a Probe 1 failure/Alarm. These parameters are set at Con 40 min/Cof 10 min. In the event that there is a Probe 1 failure/Alarm, the compressor/refrigeration system automatically starts a predetermined ON/OFF cycle, which is controlled by the Con and the Cof parameters. The customer can adjust these parameters to maintain the desired Bottle Probe temperature. During a Probe 1 failure/Alarm, the Bottle Probe temperature can be monitored by pressing the Up or Down arrow to view the High and Low Temperature History.</p> <p>Hes – Differential for Energy Reduction – This parameter is set at 4, which results in a set point of 58°F during the Energy Reduction mode. A decrease in this setting will decrease the set point, and an increase in this feature will increase the set point.</p>
AUX	<p>“AUX” indicates that the condenser fan is running. Pressing the “AUX” button on the control panel will turn it off.</p>

Alarm Codes

Message	Cause	Outputs
“P1”	Room probe failure	Toggle “Con” and “COF” based on your temperature needs
“P2”	Evaporator probe failure	Defrost end is timed
“P3”	Condenser probe failure	Outputs unchanged
“HA”	Max bottle probe temp alarm	Outputs unchanged
“LA”	Min bottle probe temp alarm	Outputs unchanged
“HA2”	Condenser high temperature	It depends on the “Ac2” parameter
“LA2”	Condenser low temperature	It depends on the “bLL” parameter
“EA”	External alarm	Outputs unchanged
“POF”	Keypad locked	Hold “Up” and “Down” buttons for 3 to 5 seconds to disable, “PON” should appear

MAINTENANCE SCHEDULE

Monthly	<ol style="list-style-type: none">1. Check filters2. Check for unusual noise or vibration
Quarterly	<p>Clean filters:</p> <ol style="list-style-type: none">1. Remove grille/ducting on both ends of unit.2. Remove the filter covering the coil.3. Wash with warm water4. Dry off filter by shaking excess water from filter.
Annually	<ol style="list-style-type: none">1. Replace filters if worn or plugged beyond cleaning.2. Use a vacuum with brush attachment to clean coils. Be careful not to crush coil fins when cleaning.3. Inspect for corrosion.4. Check wiring connections and integrity of cords.5. Examine duct work for cracks or possible leaks.

TROUBLESHOOTING GUIDE

Unit has ice forming on the evaporator	
Possible Cause	Solution
Evaporator filter and/or coil are dirty.	Clean filter and coil with a vacuum.
There is something blocking the supply and or return air	Remove blockage
One or both evaporator fans are not turning on.	Call a service tech to troubleshoot
The temperature of the room, the unit is exhausting to, has dropped below 50°	Raise the temperature of the exhaust room
The unit has not went through its defrost sequence, yet.	Wait 10 minutes to see if ice disappears
If unit continues to ice.	Call Customer Service at 800-343-9463
Unit does not run/power up	
Possible Cause	Solution
Unit is not plugged in	Make sure the unit is plugged into an outlet
Power switch not on	Turn unit on by pressing the power button on the control
No power to outlet	Reset circuit breaker on unit by pushing reset button located on right side of unit above the plug outlet
Line voltage is incorrect rating for unit	Check line voltage to make sure there is 110v/120v
Room at set point	Lower set point
Thermostat not calling for cooling	Lower set point
Faulty thermostat or wiring	Call Customer Service at 800-343-9463
Cellar Temperature is to Too Cold	
Possible Cause	Solution
The temperature of the room unit is exhausting to has exceeded 85°	Lower the temperature of the exhaust room.
The unit is undersized for the room.	Order correct size unit
There is something blocking the supply and/or return air, on evaporator or condenser side of the unit	Remove air flow obstruction
Unit is mounted too low in the cellar	Re-Locate unit so the distance from the ceiling and top of the unit is no more than 18"
One or more of the fans is not turning on.	Call Customer Service at 800-343-9463
Compressor is not turning on.	Call Customer Service at 800-343-9463
Compressor keeps cycling on overload	Make sure all fans are working and there are no airflow obstruction.
Poor seal around door.	Make sure there are no air gaps around the door. If door seal is damaged, replace it.
Controller set too high	Lower the set point.
Unit leaks water	
Possible Cause	Solution
Unit is not level	Unit should be level in wall to prevent leaking
Drain line clogged or kinked	Check drain line to make sure water can flow freely.
Drain is clogged preventing water form escaping	Clear Drain
Drain line does not have a downward slope	Fix Drain line so there is a downward slope from the unit to the drain.

TROUBLESHOOTING GUIDE

Unit runs but does not cool	
Possible Cause	Solution
Lack of air flow/heat exhaust (outer room)	Make sure fan is unobstructed; clean evaporator if necessary
Crankcase pressure set too high/low	Call Customer Service at 800-343-9463
Compressor not running	Call Customer Service at 800-343-9463
Unit undersized	Call Customer Service at 800-343-9463
Evaporator fan runs but compressor does not	
Possible Cause	Solution
Compressor and/or starting components faulty	Call Customer Service at 800-343-9463
Compressor runs; evaporator fan motor does not	
Possible Cause	Solution
Blown fuse or circuit breaker	Replace fuse/reset breaker
Faulty fan motor	Call Customer Service at 800-343-9463
Faulty fan relay	Call Customer Service at 800-343-9463
Compressor short cycles	
Possible Cause	Solution
Evaporator blows on thermostat	Move thermostat
Dual pressure control improperly set	Call Customer Service at 800-343-9463
Unit low on refrigerant charge	Call Customer Service at 800-343-9463
Condensing fan motor/capacitor faulty	Call Customer Service at 800-343-9463
Compressor and /or starting components faulty	Call Customer Service at 800-343-9463
Humidity in cellar too low	
Possible Cause	Solution
Cellar vapor barrier not sufficient	Install proper vapor barrier

TECHNICAL ASSISTANCE

WhisperKOOL Customer Service is available Monday through Friday from 8:00 a.m. to 4:00 p.m. PST.

The customer service representative will be able to assist you with your questions and warranty information more effectively if you provide them with the following:

- The model and serial number of your WhisperKOOL Series Unit.
- Location of unit and installation details, such as ventilation, ducting, construction of your wine cellar, and room size.

Contact WhisperKOOL Customer Service

1738 E. Alpine Avenue

Stockton, CA 95205

www.whisperkool.com

Email: support@whisperkool.com

Phone: (209) 466-9463

US Toll Free (800) 343-9463

Fax (209) 466-4606

INSTALLATION TERMS AND CONDITIONS

WhisperKOOL Extreme Cooling System

ATTENTION: PLEASE READ THESE TERMS OF USE CAREFULLY BEFORE INSTALLING YOUR WhisperKOOL Slimline/ Cooling System. INSTALLING YOUR WhisperKOOL Slimline/ Cooling System INDICATES THAT YOU ACCEPT AND AGREE TO EACH OF THE TERMS AND CONDITIONS SET FORTH HEREIN ("TERMS OF USE"). IF YOU DO NOT ACCEPT THESE TERMS OF USE, YOU RISK VOIDING YOUR WARRANTY AND ASSUMING ADDITIONAL REPAIR AND REPLACEMENT COSTS.

1. Acceptance of Terms and Conditions Use and installation of a WhisperKOOL Slimline/ Cooling System assumes that the consumer, ("user") fully accepts and agrees to the Terms and Conditions set forth in this document. The Terms and Conditions also state that, by signing and returning this document, you are certifying you have read, understood, and agreed to our Terms and Conditions, as well as our User's Manual. The User's Manual is shipped with each unit and, if another copy is needed, replacement copies can be downloaded from the company website (www.whisperkool.com) or by contacting WhisperKOOL directly for a new copy. WhisperKOOL reserves the right, in its sole discretion, to change its Terms and Conditions at any time, for any reason, without notice.

2. Product Installation Subject to these Terms and Conditions, when the user purchases a WhisperKOOL Slimline/ Cooling System, the user agrees to read and follow the required installation procedures set forth by WhisperKOOL for proper use and installation of the Product.

(a) It is highly recommended that you obtain the assistance of a wine storage professional.

(b) Failing to address all of the variables associated with proper installation will cause the unit to operate incorrectly and limit its ability to cool and the longevity of the unit itself.

(c) The warranty card must be returned to WhisperKOOL, the manufacturer, to ensure registration guaranteeing the full warranty period is granted. Failure to register the product within thirty (30) days of installation may result in a loss of warranty.

(d) The user is responsible for the full costs of installation and any additional parts required for the proper and complete installation of the Product.

(e) The WhisperKOOL Slimline cooling system cannot operate at its optimum capacity if airflow is constricted by ducting or venting the exhaust side of the unit into a location with inadequate ventilation.

3. Product Warranty Information If a problem arises with your WhisperKOOL system during the warranty period, you must contact WhisperKOOL Customer Service for warranty coverage and repairs.

Removing the rivets from the unit housing without authorization from the manufacturer will VOID the warranty. Please contact a customer service representative for assistance before beginning work on a WhisperKOOL unit that is still under the two (2) year manufacturer warranty.

For Slimline/ Cooling Systems returned to WhisperKOOL following warranty guidelines, WhisperKOOL warrants this product against defects in material or workmanship as follows:

(a) LABOR: For a period of two (2) years from the date of purchase. If this Product is found to be defective after undergoing customer service troubleshooting, WhisperKOOL will repair or replace the product, at its option and discretion, at no charge to the customer. After the Warranty Period, the customer is responsible for ALL labor and freight charges.

(b) PARTS: WhisperKOOL will supply, at no charge, new or rebuilt replacement parts in exchange for defective parts for a period of two (2) years.

(c) FREIGHT: During the first two (2) years from the date of purchase, WhisperKOOL will cover freight for the repair of units UNDER WARRANTY to customers within the continental United States.

This warranty does not cover cosmetic damage caused during installation or damage due to acts of God, accident, misuse, abuse, negligence, or modification to any part of the product. This warranty does not cover damage due to improper operation or lack of proper maintenance, connection to improper voltage supply, or attempted repair by anyone other than a technician approved by WhisperKOOL to service the product. This warranty does not cover products sold "AS IS" or "WITH ALL FAULTS." This warranty is valid only in the continental United States.

Proof of purchase in the form of a bill of sale or receipted invoice, which is evidence that the product is within the warranty period, must be presented to obtain warranty service. This warranty is void if the factory-applied serial number has been altered or removed from the product.

REPAIR OR REPLACEMENT AS PROVIDED UNDER THIS WARRANTY IS THE EXCLUSIVE REMEDY OF THE CONSUMER. WhisperKOOL SHALL NOT BE LIABLE FOR ANY INCIDENTAL OR CONSEQUENTIAL DAMAGES FOR BREACH OF ANY EXPRESS OR IMPLIED WARRANTY ON THIS PRODUCT. EXCEPT TO THE EXTENT PROHIBITED BY APPLICABLE LAW, ANY IMPLIED WARRANTY OF MERCHANTABILITY OR FITNESS FOR A PARTICULAR PURPOSE ON THIS PRODUCT IS LIMITED IN DURATION TO THE DURATION OF THIS WARRANTY. Some states do not allow the exclusion or limitation of incidental or consequential damages, or allow limitations on how long an implied warranty lasts, so the above limitations or exclusions may not apply to you. This warranty gives you specific legal rights and you may have other rights which vary from state to state.

4. Maintenance It is the user's responsibility to remove any accumulated dust, lint, or other debris from the front and rear intake grilles. This will restrict the airflow and may affect the unit's ability to function properly. Periodically cleaning the unit's vents will help assure maximum cooling efficiency. The drain tube must also be checked and kept clean and free of debris and mold to maintain proper performance. Mold is a natural living organism in the environment. It exists in the air in the form of microscopic spores that move in and out of buildings through doors, windows, vents, HVAC systems and anywhere else that air enters. Once it is discovered, mold must be addressed quickly and appropriately. Delayed or improper treatment of mold issues can result in costly and recurring repairs. If you suspect you have a mold problem, it is always best to hire a qualified and experienced mold remediation specialist.

5. User Costs and Responsibility The following items are not covered under warranty and are the sole responsibility of the user.

- (a) The user is responsible for ALL initial installation costs, including, but not limited to, labor costs and the cost of any additional parts necessary to complete the installation.
- (b) The user is responsible for the costs incurred for installation and removal of the product or any part thereof unless it has been defined as a warranty repair PRIOR to the work being performed.
- (c) Purchasers (users) are reminded that they should satisfy themselves that the product they are purchasing is suitable for their needs and requirements and no responsibility will be placed with WhisperKOOL for their decisions.
- (d) It is the user's responsibility to secure safe haven/storage for ANY AND ALL items that are being kept and stored in the user's wine cellar. WhisperKOOL takes no responsibility for the safety and preservation of the aforementioned items in the event that the environment becomes unsuitable for proper storage.

6. State Sales Tax

We collect California Sales Tax only for orders made and shipped within California. We do not collect sales tax for orders shipped to other states. However, you may be liable for sales tax to your state for the merchandise you receive. You may want to check with your state's tax authority for "use tax" regulations.

7. Customer Service WhisperKOOL customer service department is available Monday through Friday, from 8:00AM to 4:00PM PT by calling 1-800-343-9463.

8. Trouble Shooting The customer service department is available to answer any questions or inquiries regarding our product as well as to assist in basic and primary troubleshooting for any problems with our product.

9. General Provisions

(a) Construction and severability. Every provision of these Terms and Conditions will be construed, to the extent possible, so as to be valid and enforceable. If any provision of these Terms and Conditions so construed is held by a

court of competent jurisdiction to be invalid, illegal or otherwise unenforceable, such provision will, to the extent so held, be deemed severed from these Terms and Conditions, and all other provisions will remain in full force and effect.

(b) **Governing Law/Choice of Forum.** The laws of the State of California (without regard for conflicts of law) shall govern the construction and enforcement of these Terms and Conditions, except that the Terms and Conditions shall be interpreted as though drafted jointly by WhisperKOOL and the Purchaser. Any dispute will be resolved in a state or federal court situated in the County of Santa Clara, State of California, and the Purchaser hereby irrevocably submits to the personal jurisdiction of such courts for that purpose.

(c) **Entire Agreement/No Waiver.** These Terms and Conditions and the Limited Warranty incorporated herein by reference set forth the entire agreement between the parties and supersede all prior agreements or understandings, both written and oral, between the parties regarding the subject matter of this the Terms and Conditions and the Limited Warranty. The parties may modify these Terms and Conditions or the Limited Warranty only in a writing signed by each. No waiver by WhisperKOOL of any breach or default hereunder will be deemed to be a waiver of any preceding or subsequent breach or default.

(d) **Correction of Errors and Inaccuracies.** These Terms and Conditions may contain typographical errors or other errors or inaccuracies. WhisperKOOL reserves the right to correct any errors, inaccuracies or omissions, and to change or update these Terms and Conditions, at any time, without prior notice.

10. **Questions or Additional Information** If you have any questions regarding these Terms and Conditions or wish to obtain additional information, contact us via phone at 1-800-343-9463 or please send a letter via U.S. Mail to:

WhisperKOOL
1738 E. Alpine Ave
Stockton, CA 95205

NOTES

*Whisper***KOOL™**

WhisperKOOL
1738 E. Alpine Ave
Stockton, CA 95205
1(800) 343-9463
www.whisperkool.com

Free Manuals Download Website

<http://myh66.com>

<http://usermanuals.us>

<http://www.somanuals.com>

<http://www.4manuals.cc>

<http://www.manual-lib.com>

<http://www.404manual.com>

<http://www.luxmanual.com>

<http://aubethermostatmanual.com>

Golf course search by state

<http://golfingnear.com>

Email search by domain

<http://emailbydomain.com>

Auto manuals search

<http://auto.somanuals.com>

TV manuals search

<http://tv.somanuals.com>