

INSTRUCTION BOOK

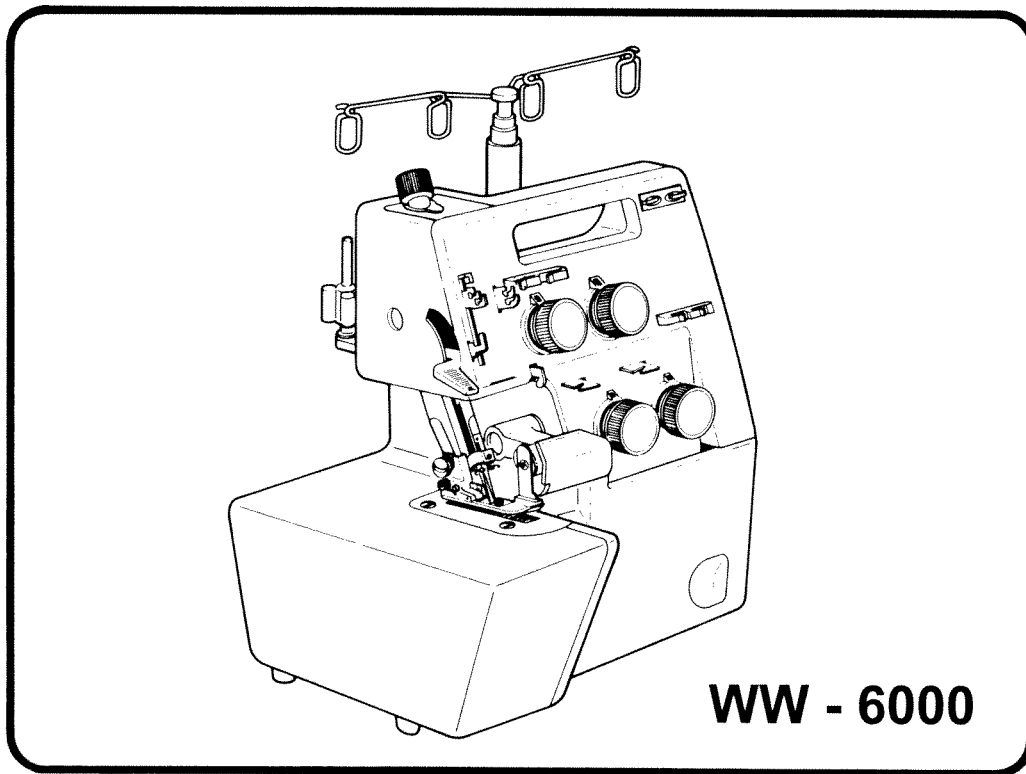

W White-Westinghouse

sewing machines

POLARIZED PLUG CAUTION

To reduce the risk of electric shock, this appliance has a polarized plug (one blade is wider than the other). This plug will fit in a polarized outlet only one way. If the plug does not fit fully in the outlet, reverse the plug. If it still does not fit, contact a qualified electrician to install the proper outlet. Do not change the plug in any way.

OVERLOCK SEWING MACHINE

Record in space provided below the Serial No. and Model No. of this appliance.

The Serial No. is located Rear of arm.

The Model No. is located Rear of arm.

Serial No. _____

Model No. WW-6000

Retain these numbers for future reference.

IMPORTANT SAFETY INSTRUCTIONS

When using an electrical appliance, basic safety precautions should always be followed, including the following:

Read all instructions before using (this appliance).

DANGER – –To reduce the risk of electric shock:

An appliance should never be left unattended when plugged in. Always unplug this appliance from the electric outlet immediately after using and before cleaning.

WARNING – –To reduce the risk of burns, fire, electric shock, or injury to persons:

1. Do not allow to be used as a toy. Close attention is necessary when this appliance is used by or near children.
2. Use this appliance only for its intended use as described in this manual. Use only attachments recommended by the manufacturer as contained in this manual.
3. Never operate this appliance if it has a damaged cord or plug, if it is not working properly, if it has been dropped or damaged, or dropped into water. Return the appliance to the nearest authorized dealer or service center for examination, repair, electrical or mechanical adjustment.
4. Never operate the appliance with any air openings blocked, Keep ventilation openings of the sewing machine and foot controller free from the accumulation of lint, dust, and loose cloth.
5. Never drop or insert any object into any opening.
6. Do not use outdoors.
7. Do not operate where aerosol (spray) products are being used or where oxygen is being administered.
8. To disconnect, turn all controls to the off ("0") position, then remove plug from outlet.
9. Do not unplug by pulling on cord. To unplug, grasp the plug, not the cord.

DANGER

1. Always unplug before relamping. Replace bulb with same type rated 15 watts.
2. Do not reach for an appliance that has fallen into water. Unplug immediately.
3. Do not place or store appliance where it can fall or be pulled into a tub or sink. Do not place in or drop into water or other liquid.

WARNING

1. Keep fingers away from all moving parts. Special care is required around the sewing machine needle.
2. Always use the proper needle plate. The wrong plate can cause the needle to break.
3. Do not use bent needles.
4. Do not pull or push fabric while stitching. It may deflect the needle causing it to break.
5. Switch the sewing machine off ("0") when making any adjustments in the needle area, such as threading needle, changing needle, threading bobbin, or changing presser foot, etc.
6. Always unplug sewing machine from the electrical outlet when removing covers, lubricating, or when making any other user servicing adjustments mentioned in the instruction manual.
7. Never operate on a soft surface such as a bed or couch where the air openings may be blocked.

SAVE THESE INSTRUCTIONS

CONTENTS

1. NAMES OF PARTS	1
2. PREPARATION FOR SEWING	2
2-1. Connecting Power Cord.....	2
2-2. Setting Telescopic Thread Stand.....	2
2-3. How to Change Threads.....	3
2-4. Replacing Needles.....	4
2-5. Threading.....	5
2-6. Preparation for Sewing and Checking.....	6
3. FOUR THREAD OVEREDGING STITCH USING 2 NEEDLES.....	7
3-1. Before Sewing.....	7
3-2. Presser Foot Lifter.....	7
3-3. Beginning and Ending of Sewing.....	7
3-4. Adjustment of The Presser Foot Pressure.....	8
3-5. Thread Tension Adjustment.....	9
3-6. Adjustments for the Differential Feed.....	11
3-7. Adjustments for Size of Bight.....	12
3-8. Stitch Length Adjustment.....	13
3-9. Sewing for Curved Seams.....	13
3-10. Standard Chart for the Thread Tension.....	14
4. SETTING WASTE TRAY.....	14
5. THREE THREAD OVEREDGING STITCH USING ONE NEEDLE.....	15
6. ROLL HEMMING.....	16
7. PIN TUCKING.....	18
8. CORDED OVERLOCK.....	19
9. REPLACING THE CUTTING KNIVES.....	19
10. CHANGING THE LIGHT BULB.....	20
11. LUBRICATION.....	20
12. TABLE OF SEWING MATERIALS, NEEDLES AND THREAD.....	21
13. ACCESSORIES.....	22
14. SPECIFICATIONS.....	23

1. NAMES OF PARTS

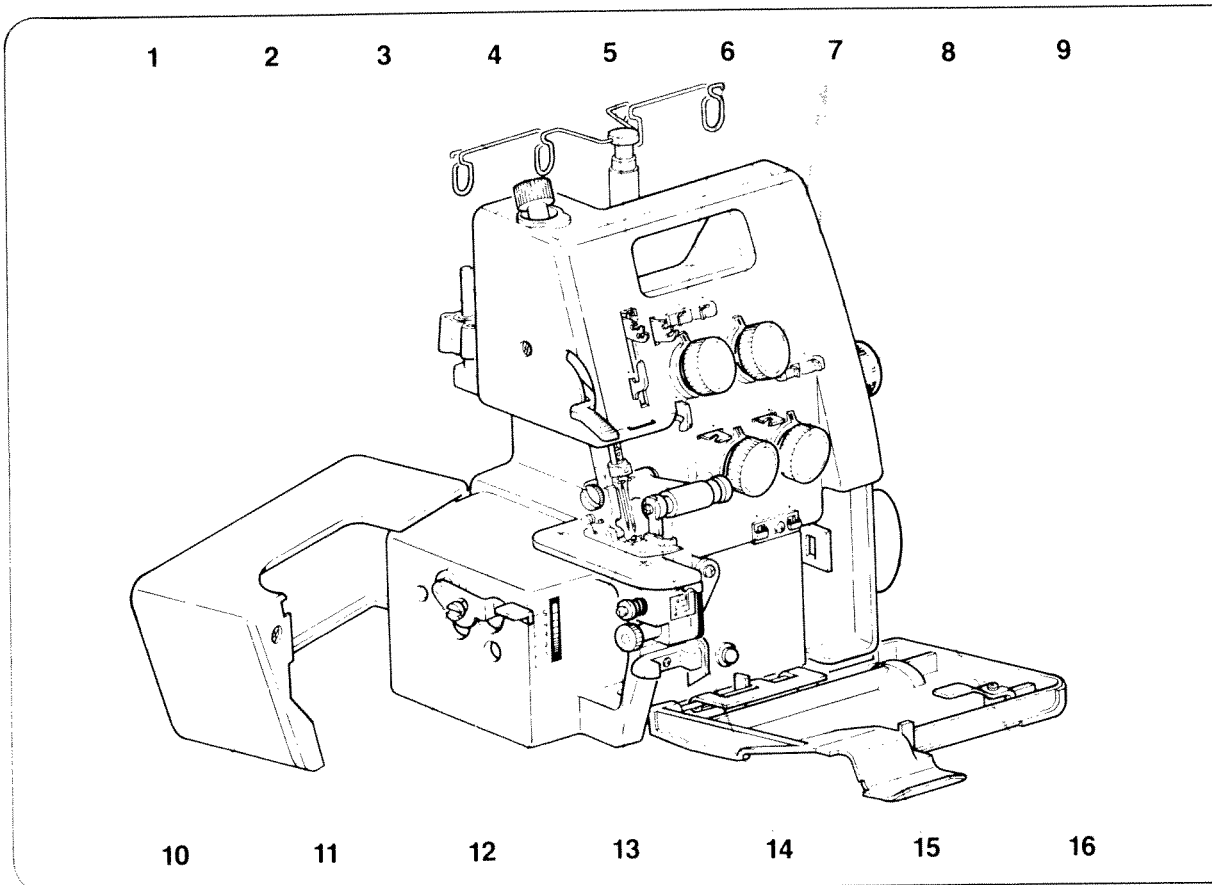

1. Spool pin
2. Presser foot lifter
3. Pressure regulator screw
4. Telescopic thread stand
5. Thread take up lever
6. Thread tension support
7. Thread tension dials
8. Front panel
9. Differential feed dial
10. Side cover
11. Stitch length adjuster
12. Presser foot
13. Bite width adjusting dial
14. Upper knife
15. Front cover
16. Handwheel (Right side of machine)

2. PREPARATION FOR SEWING

2-1. Connecting Power Cord

Connect foot controller and power cord ① ②.

Before plugging in your machine, be sure that the voltage is same as that of your machine. (written on a plate at back of machine).

⚠ Specifications vary from country to country.

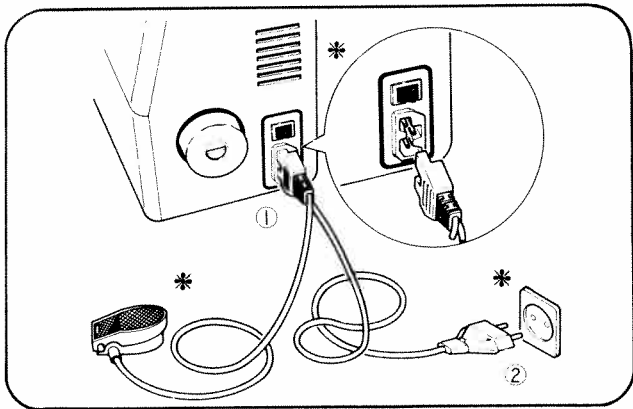

Press the switch on the machine to turn on the power and the sewing light.

Always switch off or unplug machine when not in use.

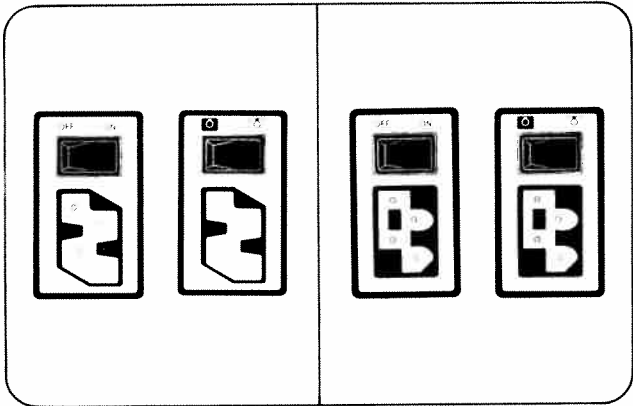

The more you press foot controller, the faster the machine runs.

When the power switch is turned off, the machine will not operate even by pressure on the foot controller.

* Electronic type of controller

This foot controller is powerful and stable, even at a slow speed.

It is possible to operate simply and produce neat finish, even detailed operation.

* Electronic type of foot controller

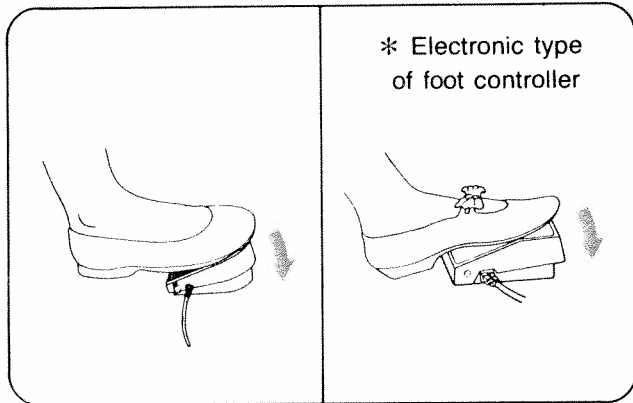

2-2. Setting Telescopic Thread Stand

Extend the telescopic thread stand to its full height, then turn it until the shaft clicks into its locked position.

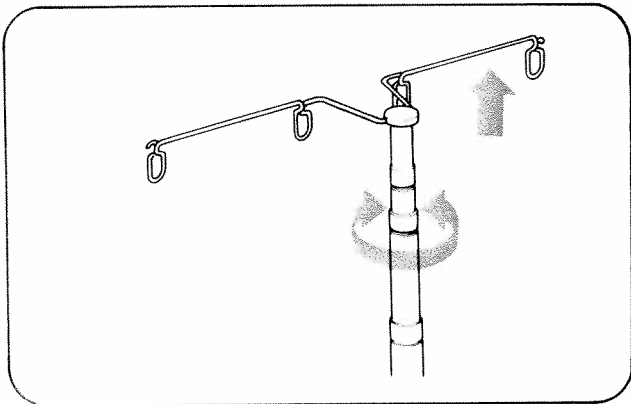

2-3. How to Change Threads

The machine is supplied with thread but the following is an easy way to change them:

(1) Cut the thread in use near the cone spool (behind the telescopic thread stand). Place the new thread on the spindle and tie it to the end of the original thread.

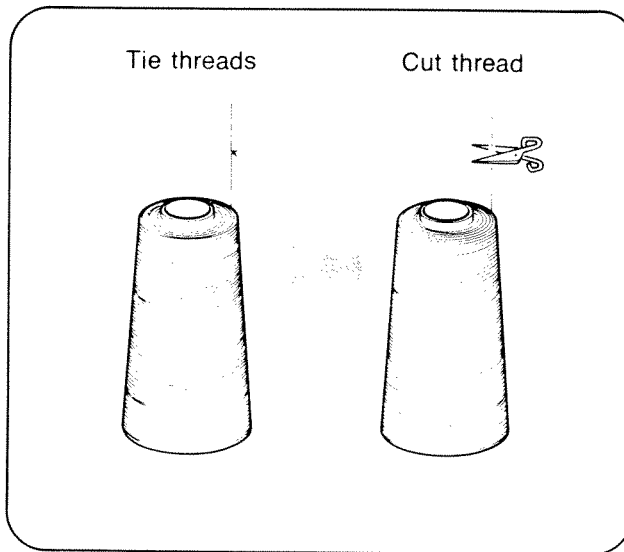

(2) Lower the presser foot lifter to lift up the presser foot.

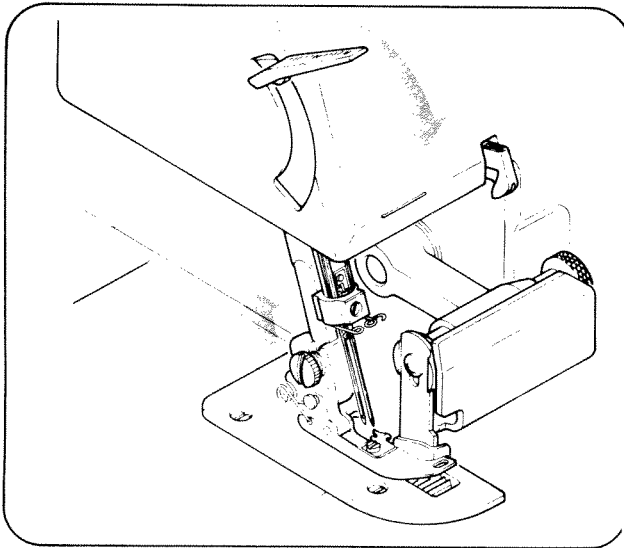

(3) Set tensions to 0 so that the thread knot can pass through smoothly, draw out the looper thread until the thread knot comes to about 10 cm past the presser foot.

(4) When changing the needle thread, cut off the thread knot before it reaches the eye of the needle to avoid bending the needle as the knot is pulled and caught in the needle's eye.

To make the above threading easier, use tweezers.

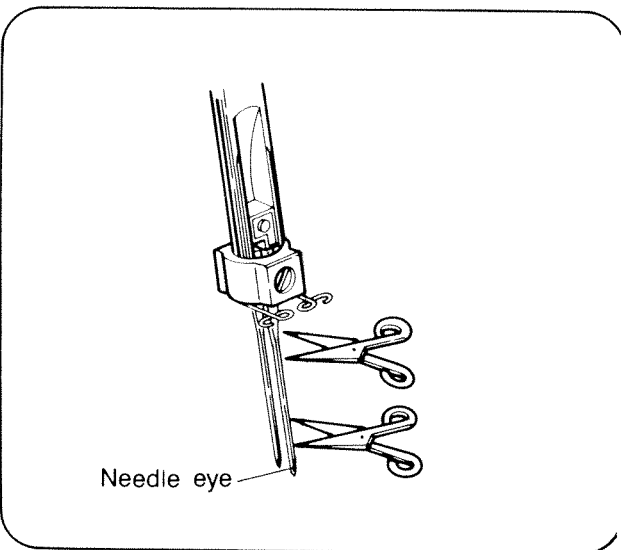

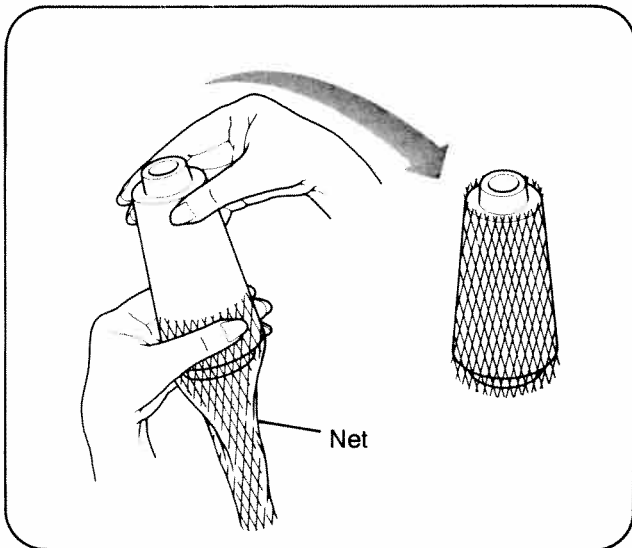

Cover the spool with the "NET" as chemical fibers (fibres) and the like are easily frayed.

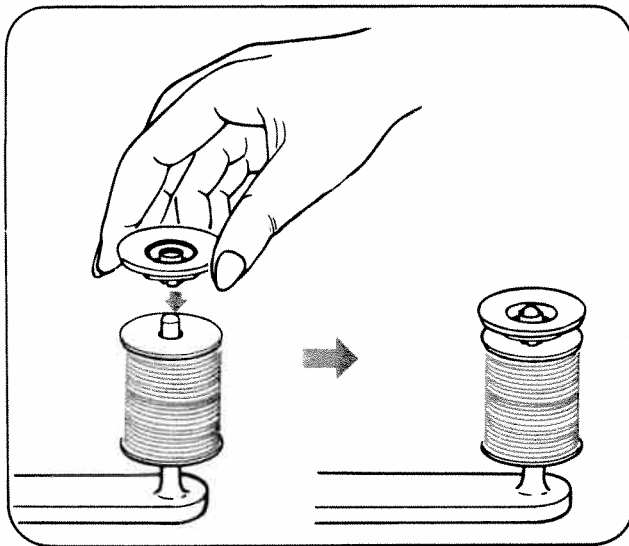

When using a real type thread spool, insert the spool adapter (supplied with the machine) (as shown).

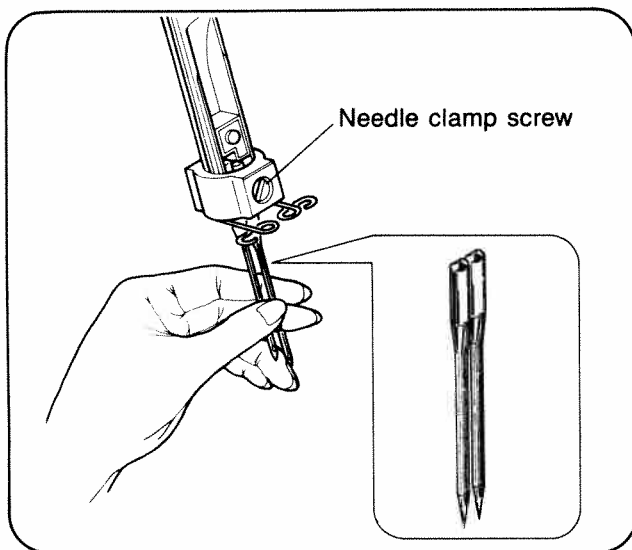

2-4. Replacing Needles

Replace needles in the following way:

Note: be sure to take out the power supply plug before replacing needles.

(1) Bring needles to their highest position by turning handwheel towards you.

(2) Loosen the needle clamp screw and remove the two needles together.

(3) With the flat side away from you, insert the new two needles together into the groove of needle bar as far as it will go.

Use "HA × 1SP (705/130)" #11(80) or #14(90) or ones the same as for home-use sewing machine.

2-5. Threading

When threading the machine from the beginning, threading must be carried out in the following sequence:

First: Lower looper threading (A)

Second: Upper looper threading (B)

Finally: Needle threading (C, D)

(1) Lower looper threading (A)

Push the front cover to the right, and fold it down towards you. Take the thread drawn from the spool and pass it, through guide 2 of the thread stand and then, in order, through guides 3, 4, 5 and thread tension dial 6. (Fig. A)

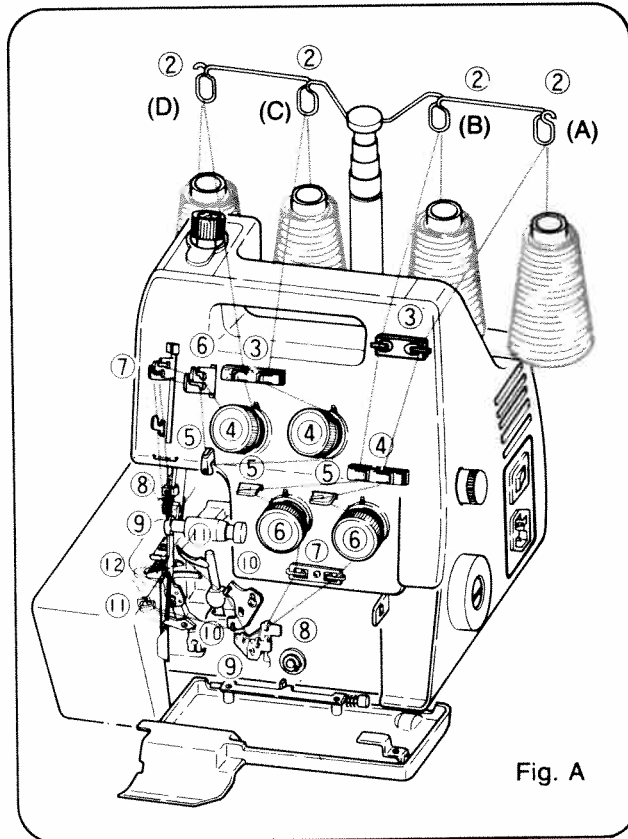

Fig. A

Pass the thread through guides 7, 8, 9 and 10. Bring the lower looper to the far left position by turning handwheel towards you, and pass the thread through lower looper thread guide 11. Then, move the lower looper slightly to the right by turning the handwheel towards you. (Fig. B)

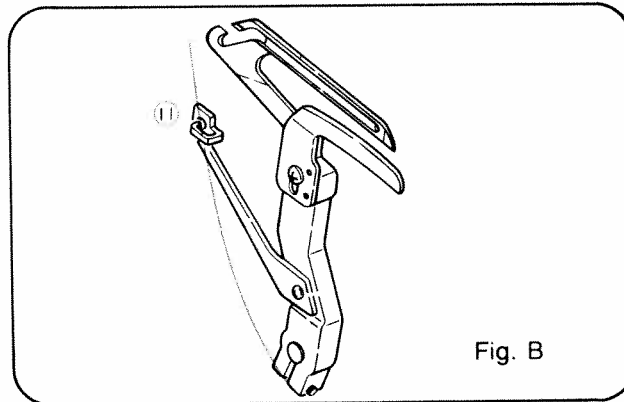

Fig. B

Pass the thread through lower looper thread guide 12 as shown. (Fig. C)
Then thread the hole of lower looper 13 using tweezers. Cut the thread leaving about 10 cm (4") of spare thread. (Fig. D)

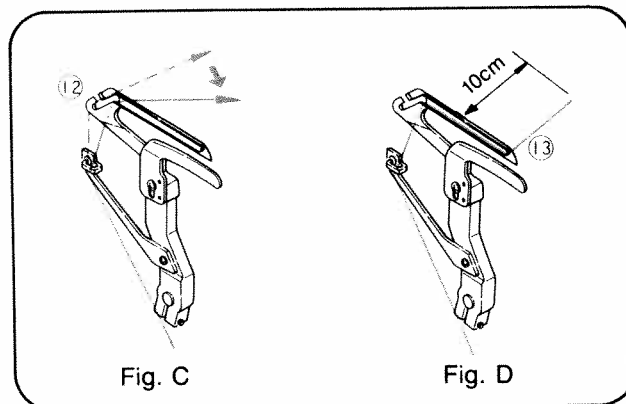

Fig. C

Fig. D

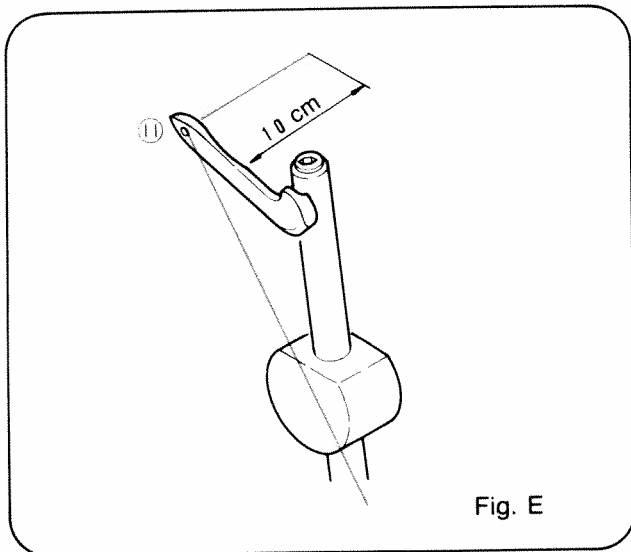

Fig. E

(2) Upper looper threading (B)

- Bring the upper looper to its lowest position by turning handwheel toward you.
- Draw thread from spool and pass it, through guide ② of the thread stand and then, in order, through guides ③ ~ ⑩ (Fig. A).
- Thread the hole of upper looper ⑪ using tweezers. Cut the thread leaving about 10cm (4") of spare thread (Fig. E).
- Close the front cover.

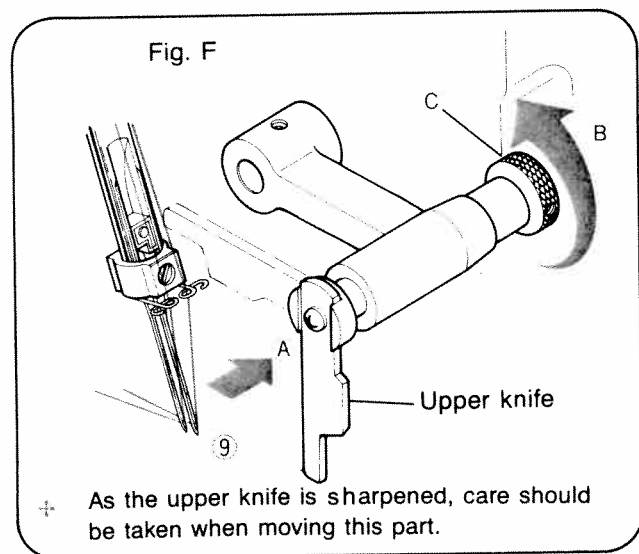

Fig. F

Upper knife

+ As the upper knife is sharpened, care should be taken when moving this part.

(3) Right needle threading (C)

- For ease in threading, push the upper knife holder screw from A side with the forefinger of your left hand * and grasp the right end of the holder C and turn it in the direction of arrow B with your right hand. (Fig. F)
- Take the thread drawn from spool, and pass it through thread guide ②~⑧, then thread to the right-hand needle's eye ⑨ from front to back.
Cut the thread leaving about 10cm (4") of spare thread. (Fig. A)

(4) Left needle threading (D)

- Take the thread drawn from spool, and pass it through thread guides ②~④, ⑥~⑧, and thread the left-hand needle's eye ⑨ from front to back (Fig A, F).

2-6. Preparation for Sewing and Checking.

- Check that no thread slips off or snaps.
- Confirm that the upper knife moves against the lower knife correctly by turning the handwheel slowly towards you. If it is not correct, check if there is any fabric or waste thread between knives.
- Turn the handwheel towards you with your right hand to check that the thread winds around the stitch finger of the needle plate.
If the thread doesn't wind around the stitch finger of the needle plate, check if any threads are threaded incorrectly.

3. FOUR THREAD OVEREDGING STITCH USING 2 NEEDLES

3-1. Before Sewing

After threading is completed, and when the threads are not wound around the stitch finger, gently draw out the four threads under and behind the presser foot, and turn the handwheel towards you by hand two or three times to make the thread wind on to the needle plate.

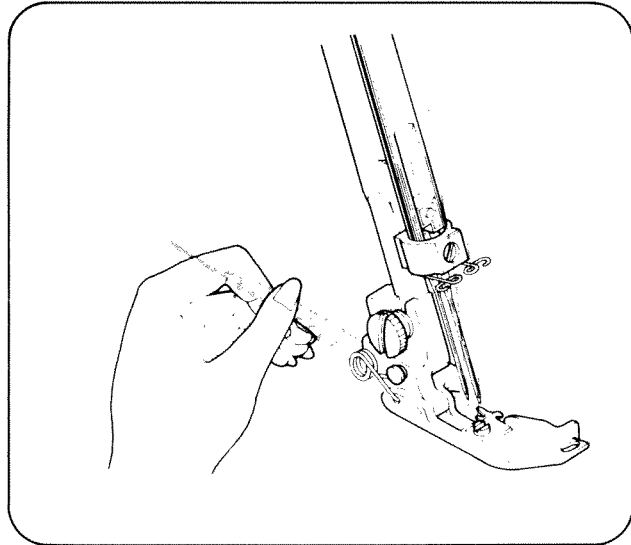

3-2. Presser Foot Lifter

For setting average material, there is no need to lower the presser foot lifter.

When beginning to sew, push the material just in front of the presser foot and it will be fed through. For the thick material, lower the presser foot lifter, place the material under the presser foot, then raise the presser foot lifter.

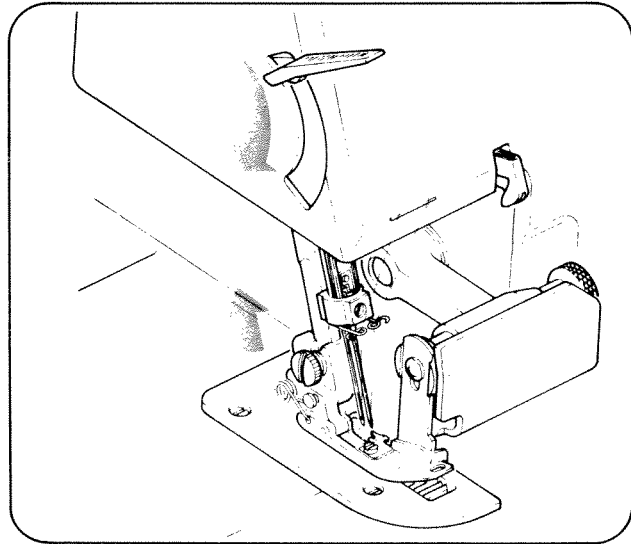

3-3. Beginning and Ending of Sewing

(1) Beginning to sew

Just put your left hand on the material to push it slightly until the tip of the fabric comes exactly behind the presser foot.

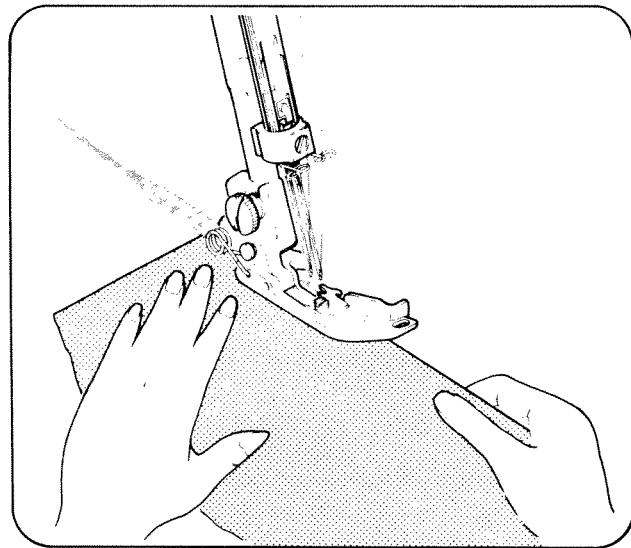

(2) Ending of sewing

Make chain-stitches at the end of the sewing to prevent the thread from untying and to prepare for the next sewing.

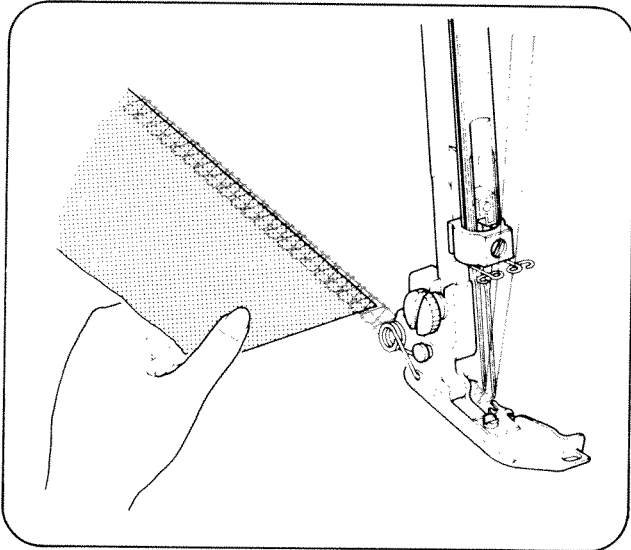

Draw the finished fabric gently backwards and to the left as the machine is operating and make chain-stitches. This is called chain-stitch sewing. Then cut the thread 2 ~ 5cm (1-2") from the presser foot.

⚡ Do not pull it out roughly as the needle will bend and break.

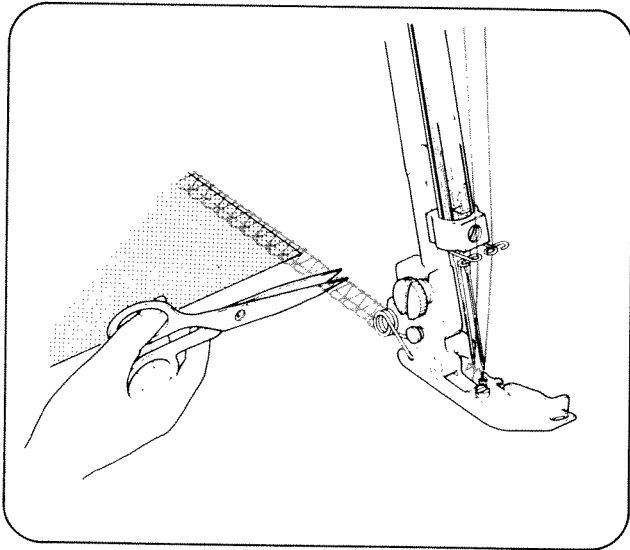

3-4. Adjustment of the Presser Foot Pressure

The presser foot pressure is pre-adjusted for materials of medium (standard) thickness. Adjustment is necessary only when you work on very thin or very thick materials. Accordingly, sew thinner materials with less pressure and thicker materials with more pressure. Increase the pressure of the presser foot by tightening the adjustment screw.

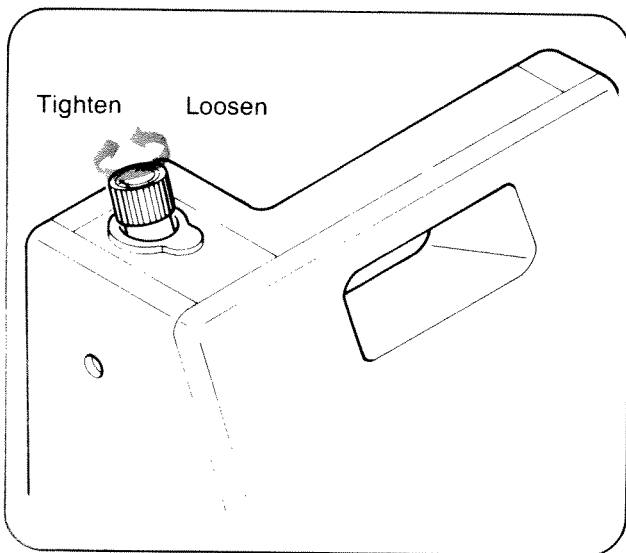

3-5. Thread Tension Adjustment

Set the balance of the tension as weak as possible.

Balance of the Loopwre thread:

When the lower looper thread is pulled to the top of material, loosen tension dial 3 counter-clockwise. (or tighten tension dial 4 clockwise.)

When the upper looper thread is pulled to the underside, tighten tension dial 3 clockwise. (or loosen tension dial 4 counter-clockwise.)

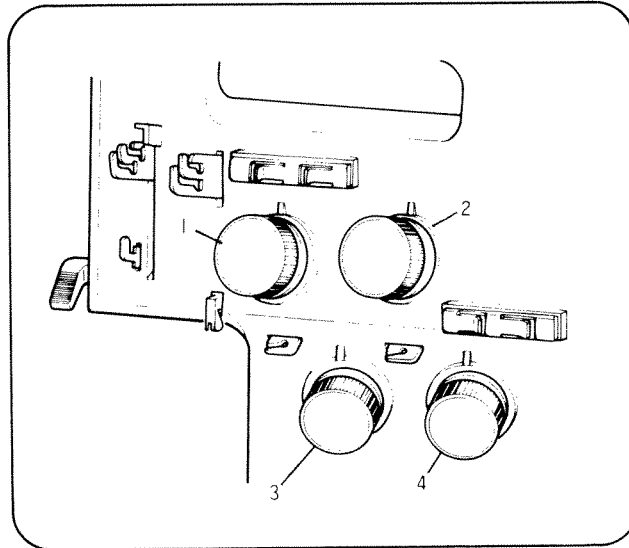

(1) Correct tension.

- Lower looper thread and upper thread should be well balanced with same tension. (Both looper threads should make crosses at the edge of the fabric.)
- Needle thread should not be slacken, or pulled.

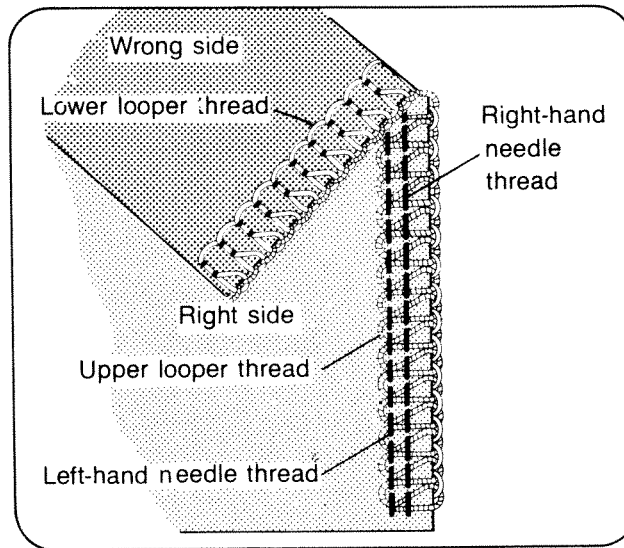

(2) Unbalanced upper looper thread wraps round and over the back:

Tighten the thread tension of the upper looper (Dial 3) or loosen the thread tension of the lower looper (Dial 4).

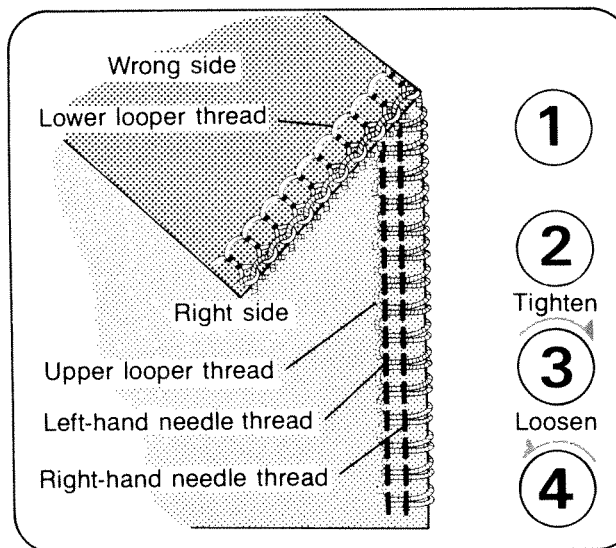

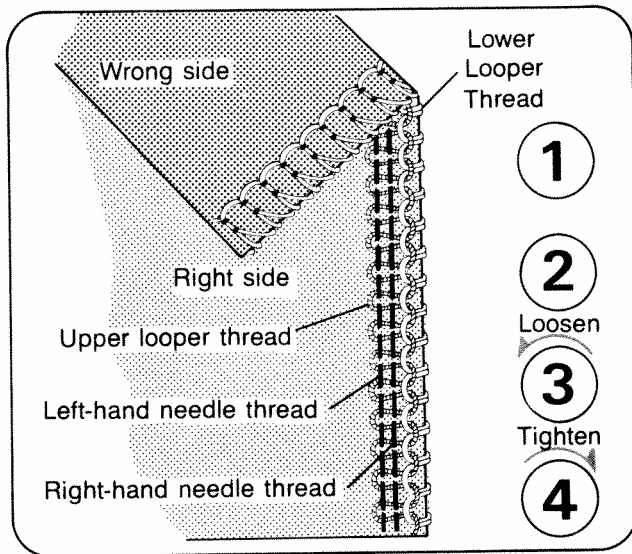

(3) Unbalanced lower looper thread wraps round and over the face:

Tighten the thread tension of the lower looper (Dial 4) or loosen the thread tension of the upper looper (Dial 3).

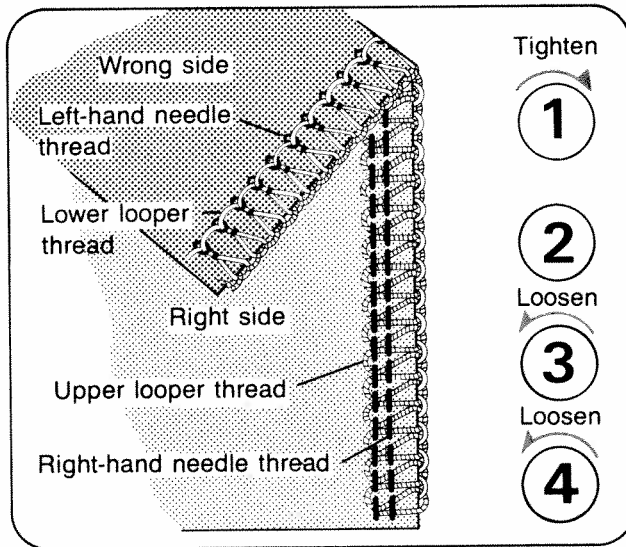

(4) Unbalanced left needle thread too loose:

Tighten the thread tension of the left needle (Dial 1) or loosen both looper thread (Dial 3 and 4).

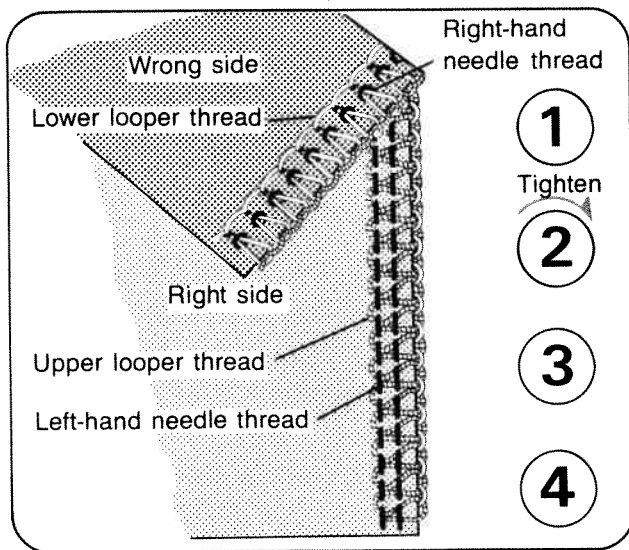

(5) Unbalanced right needle thread too loose:

Tighten the thread tension of the right needle (Dial 2).

3-6. Adjustments For The Differential Feed

Differential feeding performs the function of stretching or condensing the edge of the fabric, since two independent feed dogs, one in front and one behind the needles, can be adjusted to feed at different ratio.

The function has the effect of producing a neat finish of overedging for stretchable and condensable fabrics.

* "N" indicates the neutral position.

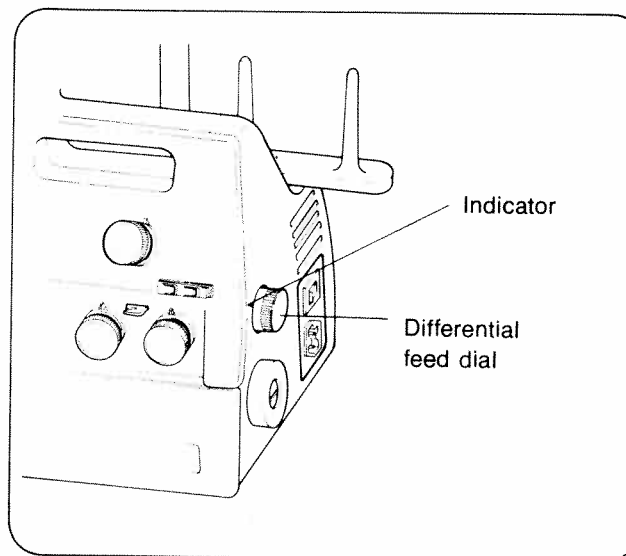

Refer to the below chart and test stitch performance on a scrap of material you are going to use.

	Fabric	Differential feed ratio is set "N".	Differential feed ratio	Result of adjustment
Stretchable materials	Knit Jersey		N-2	
Unstretchable and uncondensable materials	Medium woven fabrics		N	
Condensable materials	Georgette		0.7-N	

3-7. Adjustments for Size of Bite.

- Adjust the size of the bite from 4.2mm (0.16") to 6.0mm (0.23") according to the kind of material.
- The standard bite size is 4.5mm (0.17")
- Open the side cover to adjust the bite size.

(1) If the cutting width is narrower than the bite size, turn the bite width adjusting dial to the direction of arrow. (To bigger number)

(2) If the cutting width is wider than the bite size, turn the bite width adjusting dial to the direction of the arrow. a smaller number)

The right figure shows that the size of the bite between the left needle and the edge of the material 4.5mm.

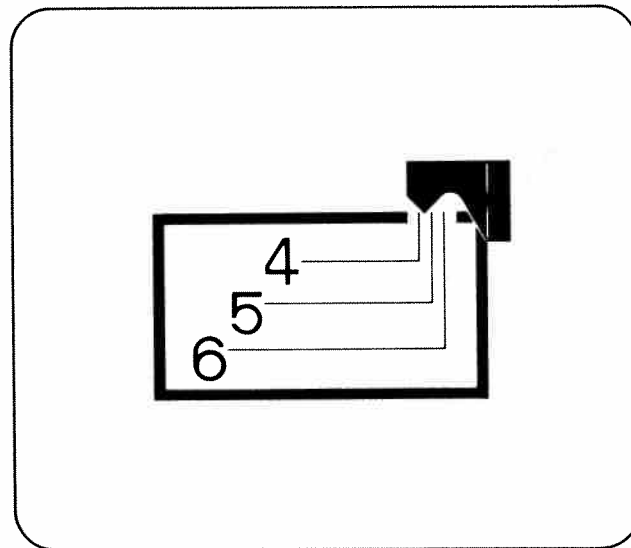
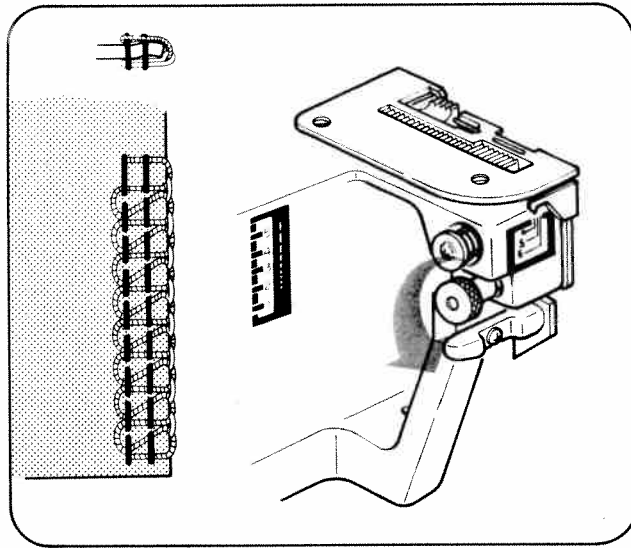
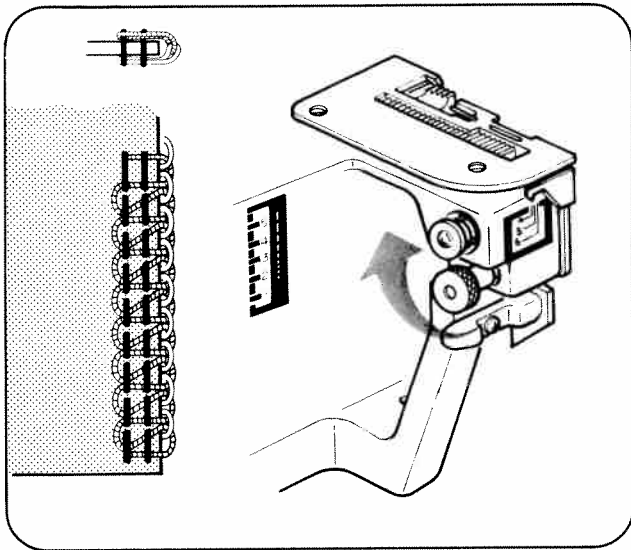

3-8. How to Adjust Stitch Length

The machine is pre-set to a 2.5mm stitch length for regular seaming and overedging. You may adjust the stitch length from 1mm (Narrow rolled hemming) to 5mm by one-touch of the stitch length adjustment lever.

- ✦ For normal overedging set the stitch length from 2.5mm to 5mm. A stitch length less than 2.5mm is used only for rolled hemming.

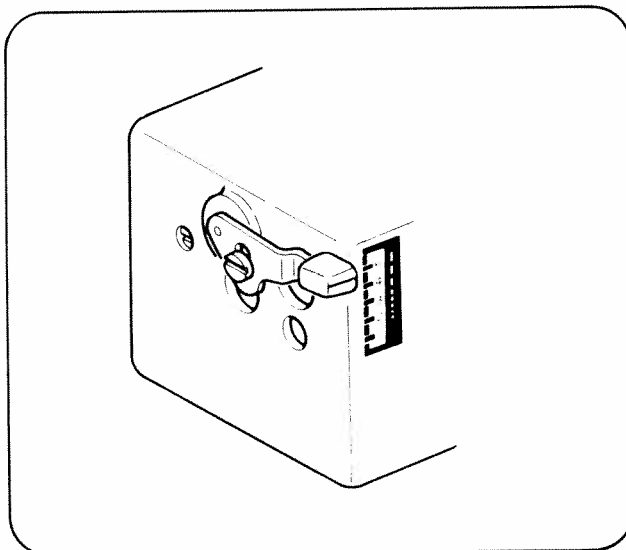

3-9. Sewing for Curved Seams

For a neat and clean finish of curved seams:
For inside curves, guide the fabric gently with the trimming line of the fabric under the right front of the presser foot, applying pressure to the fabric with your left hand, at the same time, apply a little pressure in the opposite direction with your right hand as shown.

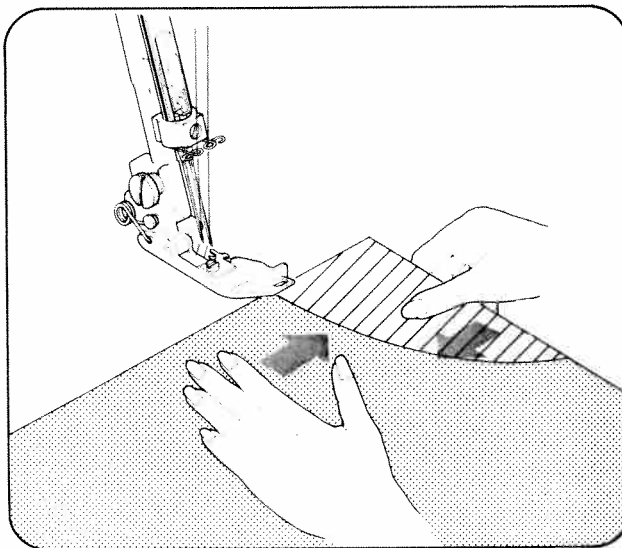

For outside curves, apply pressure in the opposite directions of the above.

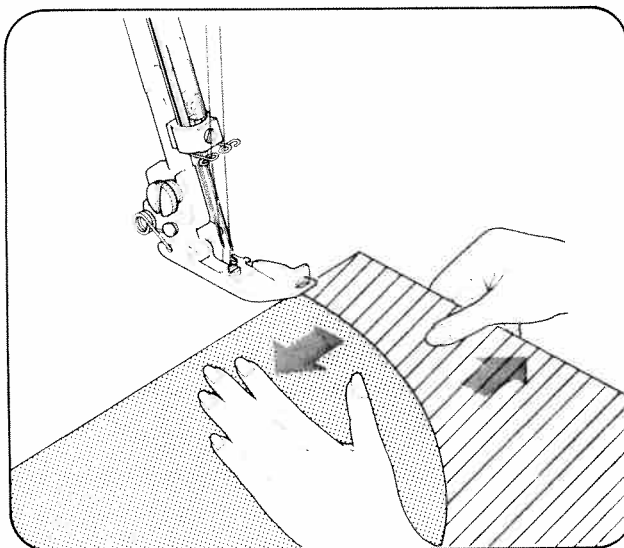

PATTERN STITCHES	OVEREDGING	ROLL HEMMING	FINE ROLL HEMMING
STITCH LENGTH	2.5 - 5 mm	1 - 1.5 mm	1 - 1.5 mm
NEEDLE THREAD	2 - 4	1 - 4	1 - 4
UPPER LOOPER THREAD	1 - 4	1 - 4	2 - 4
LOWER LOOPER THREAD	2 - 4	5 - 8	2 - 4

3-10. Standard Chart for the Thread Tension

The tension for each of the thread tension dials should be different according to the pattern stitches as in the chart on the right. Since the figures in the chart are for average strength of threads tension, it may be necessary to adjust the thread tension a little. Thread tensions will differ according to the kind of fabric and the thread. The differential feed ratio is normally "N". (See P.11).

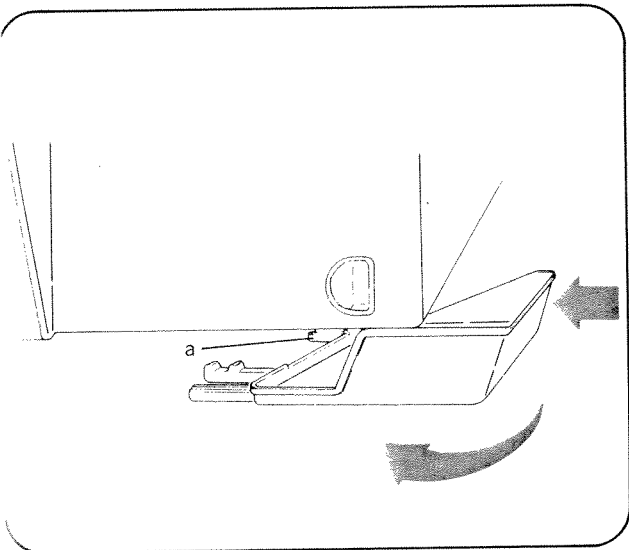

4. SETTING WASTE TRAY

(1) Insert the right guide 'a' of the waste tray to the right leg of the overlock machine as illustrated. Turn the waste tray in the direction of arrow.

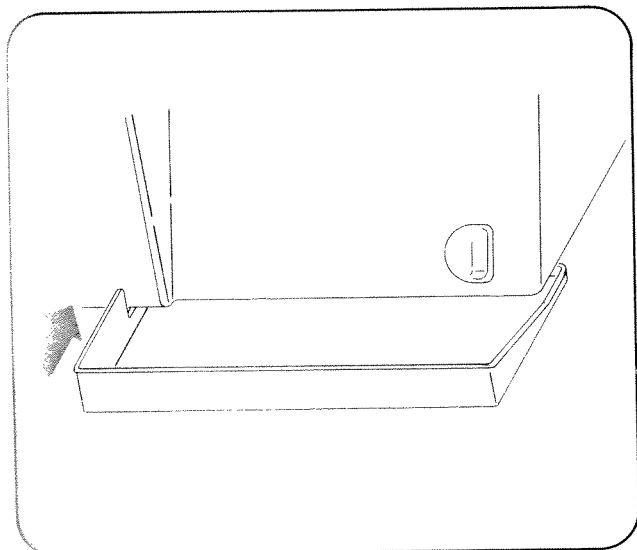

(2) Push the left end of the waste tray in the direction of arrow.

5. THREE THREAD OVEREDGING STITCH USING ONE NEEDLE

Though this machine is made mainly for 4 thread overedging using 2 needles, three-thread overedging using 1 needle can be easily operated by just removing 1 needle.

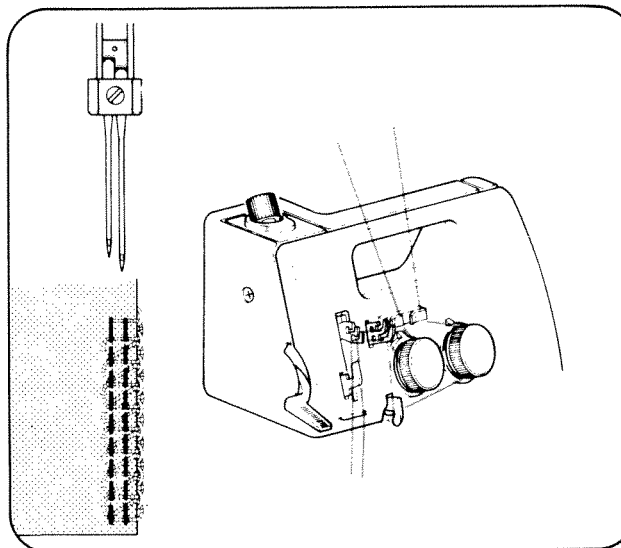

(1) By removing the right needle.

Three-thread overedging stitch using 1 needle for as wide as a 4-thread overedging stitch using 2 needles can be achieved.

Use the left thread tension. (Dial ①). the bite width is normally 4.5 mm.

The differential feed ratio is normally "N".
(See P.11)

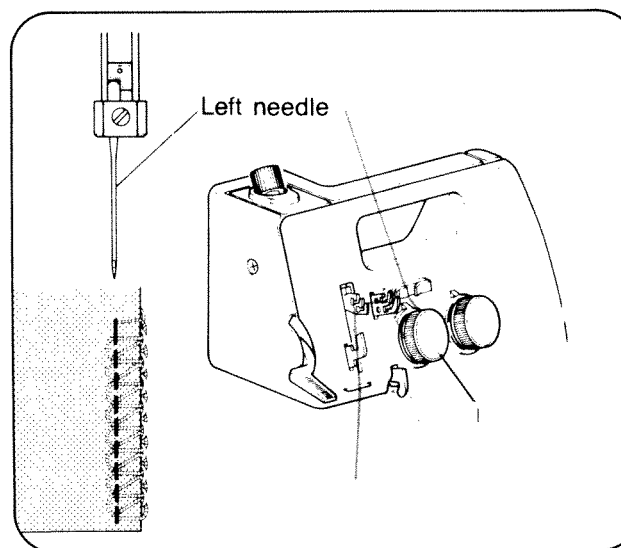

(2) By removing the left needle.

The right needle sews with a narrow width bite. Use the right thread tension. (Dial 2) The bite width is normally 2.5 mm.

The differential feed ratio is normally "N".
(See. P.11)

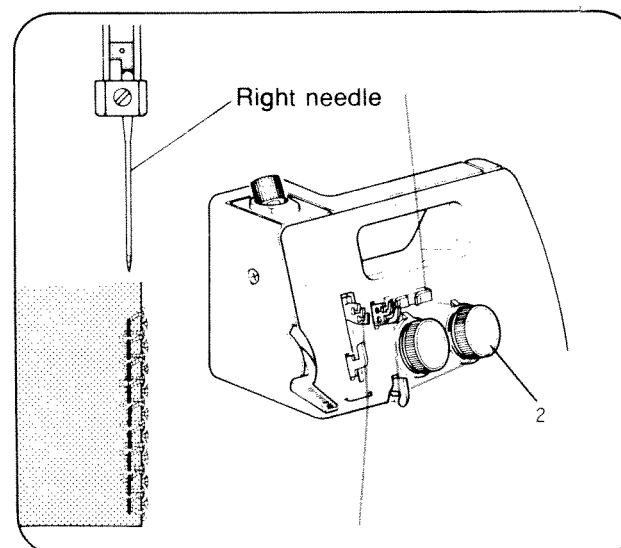

Roll Hemming

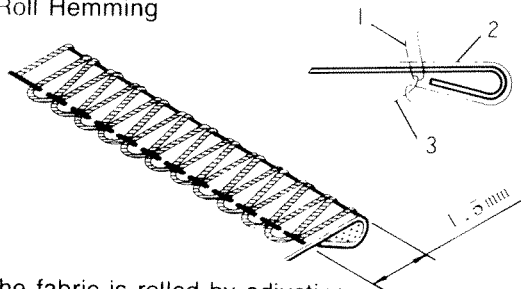

The fabric is rolled by adjusting. The thread tension and is overlocked with upper looper thread.

6. ROLL HEMMING

Roll hemming is achieved by rolling the fabric and overlocking. the 2 types as illustrated on left is ideal for use with thin materials.

Fin Roll Hemming

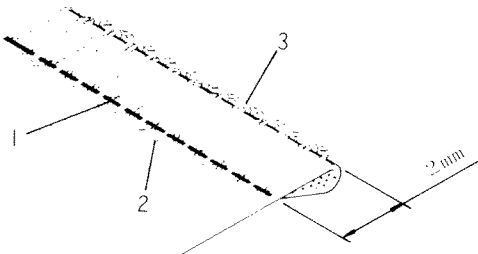

The fabric is rolled and overlocked with upper and lower looper thread.

(1)

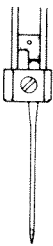

(2)

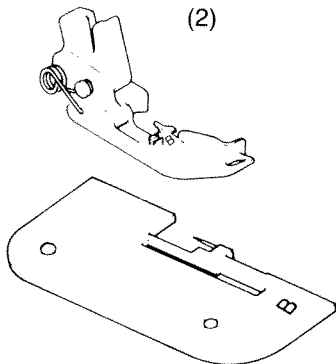

(1) Remove the left needle. (Sew only with the right needle)

(2) Change the presser foot and the needle plate for roll hemming.

For roll hemming sewing, use the presser foot marked "B" and the needle plate "B". (The presser foot "A" and the needle plate "A" are for normal sewing).

CHANGING PRESSER FOOT AND NEEDLE PLATE

- ① Raise up the upper knife. (See P6)
- ② Set the needle to the highest position by turning the hand wheel toward you.
- ③ Lower the presser foot lifter.
- ④ Loosen the presser foot thumb screw in the direction of arrow and remove the presser foot.
- ⑤ Loosen the screw a and b on the needle plate with the larger screw driver and remove them.

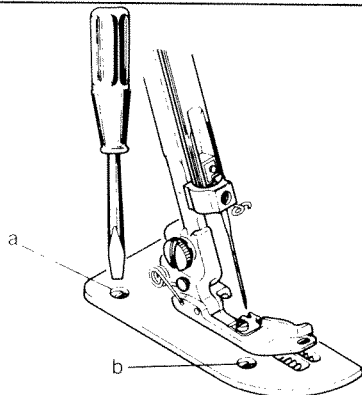

- ⑥ Set the needle plate for roll hemming and tighten the screw a and b on it.
- ⑦ Set the presser foot for roll hemming and tighten the presser foot thumb screw in the direction of arrow.
- ⑧ Put the upper knife back where it was.

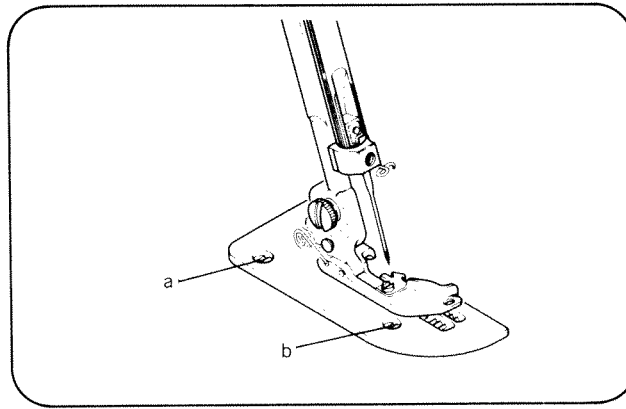

STANDARD CHART FOR ROLL HEMMING

		ROLL HEMMING	FINE ROLL HEMMING
BITE WIDTH		5 - 6 mm	5 - 6 mm
STITCH LENGTH		1 - 1.5 mm	1 - 1.5 mm
DIFFERENTIAL FEED RATIO		N	N
THREAD TENSION	NEEDLE THREAD	1 - 4	1 - 4
	UPPER LOOPER THREAD	1 - 4	2 - 4
	LOWER LOOPER THREAD	5 - 8	2 - 4

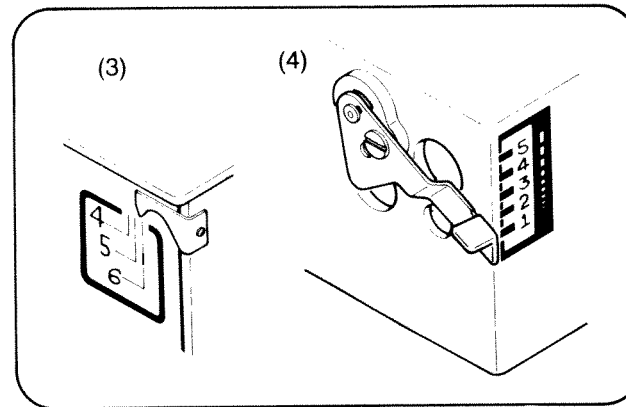

- ✦ The figures in the above chart may be a little different according to the kind of the fabric and the threads. (See P.20 and P.11)
- ✦ For roll hem sewing, pass the needle thread to the left side (solid line) of thread guide a as illustrated. (For normal sewing, pass it to the right side (dotted line) of thread guide a)

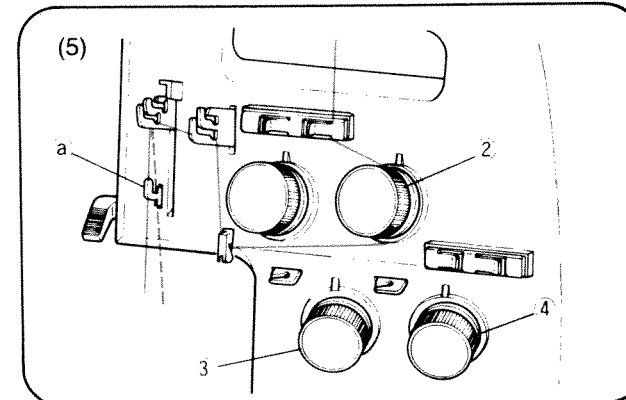

- (3) At the beginning of sewing, gently pull the end of the thread chain.
- For roll hem sewing, pull the material gently towards the rear of the machine, and you'll get neater stitches.

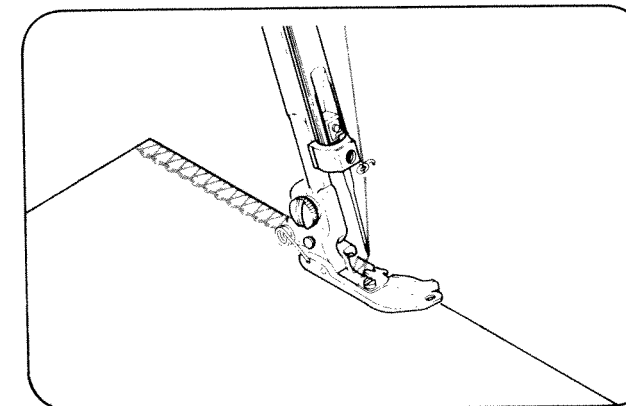

7. PIN TUCKING

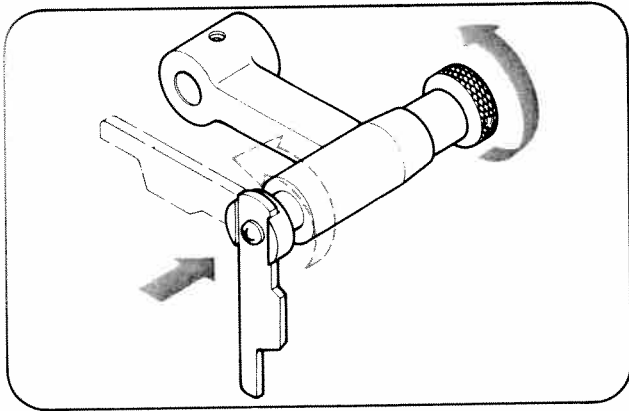

Pin tucking is overlapped so avoid cutting the fabric by raising the upper knife.

Pin tucking is suited to the design of a child's clothing and a lady's blouse.

* Use the presser foot marked "A" and needle plate "A".

(1) Remove the left or right needle to your required width. (Sew only with the one needle.)

(2) Raise the upper knife. (See P.6)

* Lower the presser foot lifter.

(3) The tension is set the same as the one for overedging. (See P.14)

* The fabric is ironed along the line of the pin tucking in advance.

* The differential feed ratio is normally "N".

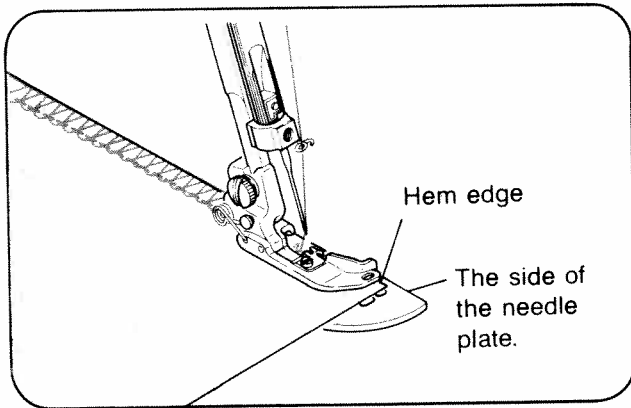
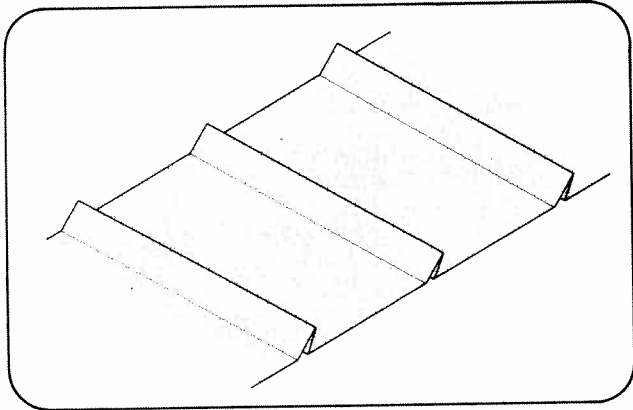

(4) Place the fabric under the presser foot with the hem edge in line with the side of the needle plate and start to sew.

Raise up the presser lifter.

* Make chain-stitch at the end of the sewing.

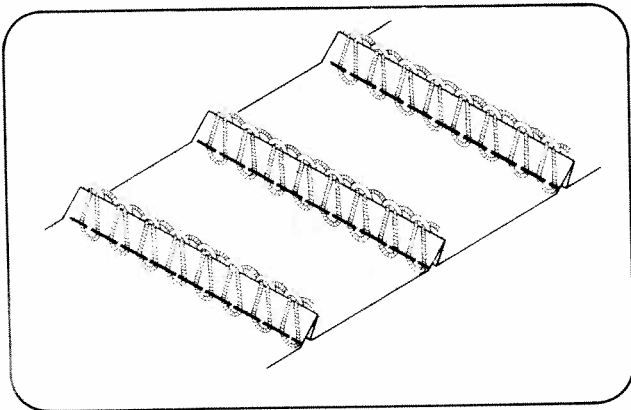

(5) The hem edge is ironed to one side when your sewing is finished.

8. CORDED OVERLOCK

Corded overlock can be used to strengthen stitches when joining elastic materials such as knitted fabrics.

There are two ways of corded overlock.

(1) Place the slightly wide cord (about 3mm) under the right needle, and sew on.

(2) Sew a narrow cord, positioning it on the edge of the overlocked stitch.

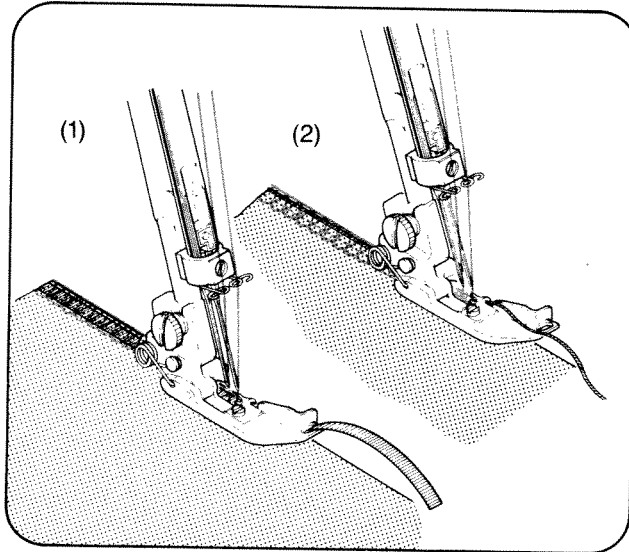

9. REPLACING THE CUTTING KNIVES.

The upper knife and lower knife are made of a special long-lasting steel and will seldom have to be replaced. However, when they do not cut the fabric even though they are set in the right position, replace them in the following way:

Before replacing the knife, be sure the power supply plug is take out.

Move the front cover to the right, then open it toward you.

(1) Replacing the lower knife:

Loosen the lower knife clamp screw and change the knife for a new one. Align the top of the lower knife with the top of the needle plate.

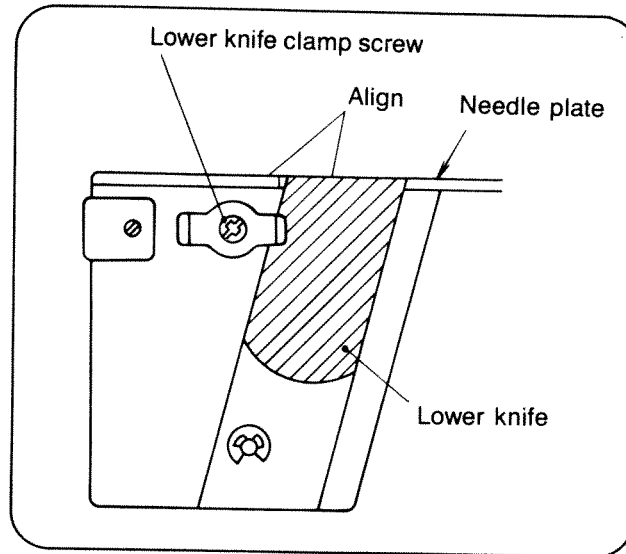

(2) Replacing the upper knife:

Move the upper knife to its lowest position by turning the handwheel towards you.

Loosen the upper knife screw, while holding the upper knife. Change the knife for a new one.

Check if the biting position (A) of upper knife is positioned downwards 0.5 ~ 1.0 from the top of biting position of lower knife.

Tighten the upper knife screw.

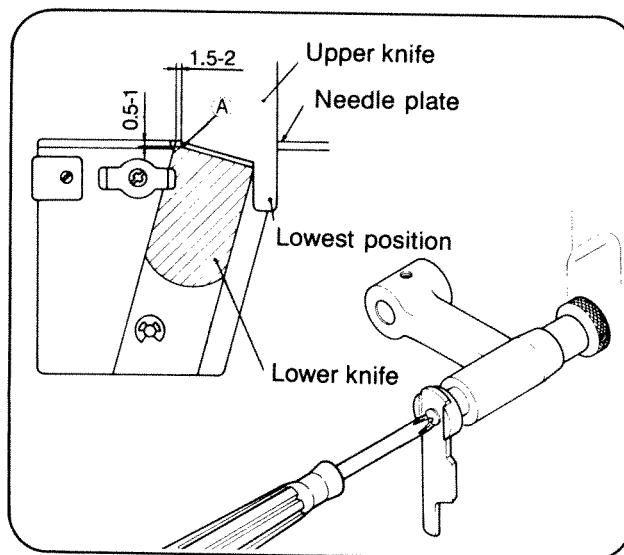

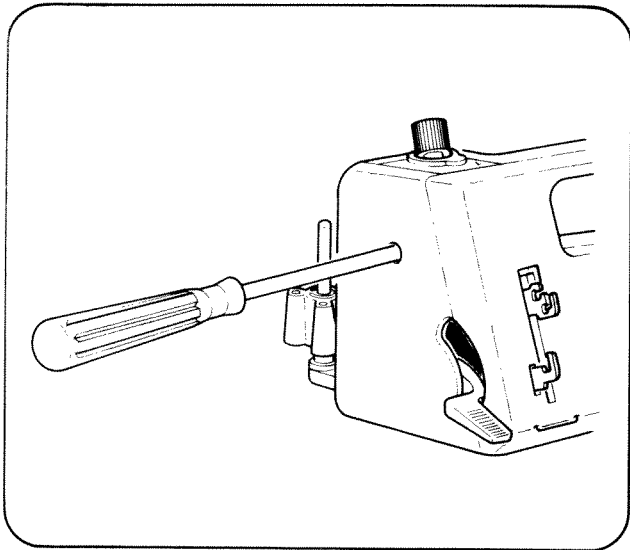

10. CHANGING THE LIGHT BULB

When the light does not come on even though it is switched on:

- (1) Take out the power supply plug.
- (2) Remove the lamp cover.
- (3) Change the light bulb.
- (4) Replace the lamp cover.

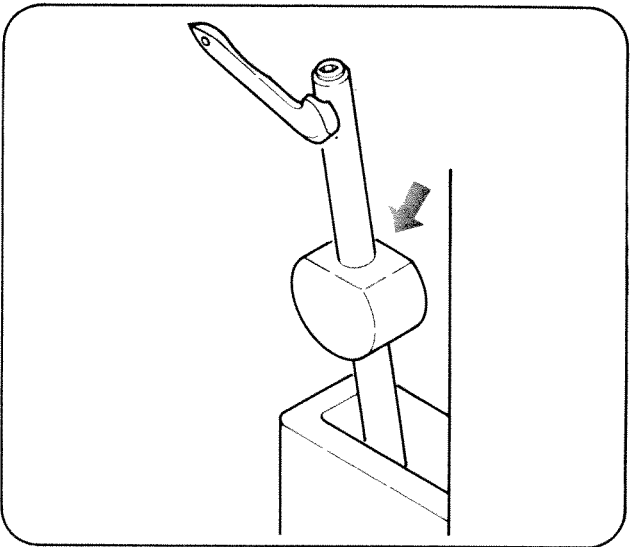

11. LUBRICATION

Lubrication is not necessary for this machine since the important parts are all made of a special oil impregnated sintered metal. However, one or two drops of oil will increase durability.

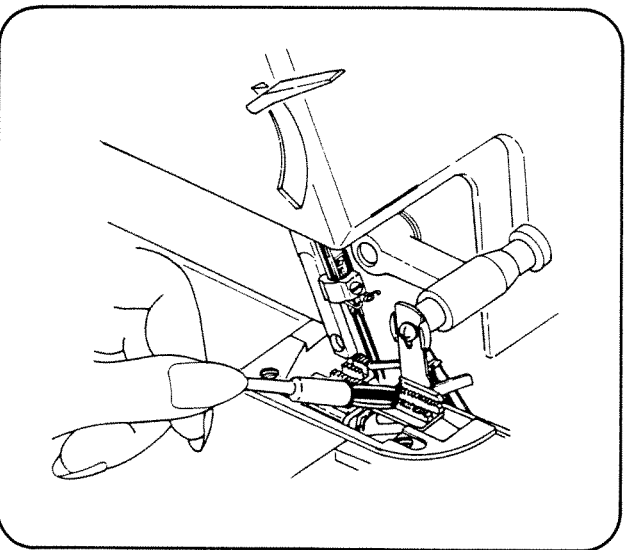

CLEANING

First disconnect machine from power supply by removing plug from the electric outlet.

1. Open front cover and side cover. (See Page 3)
2. Using the brush provided, remove all the dust and lint that has accumulated.

STORAGE

1. When the machine is not in use, please disconnect it from the power supply by removing plug from the electric outlet.
2. Using the vinyl cover provided please cover your machine when you finish your sewing.
3. Store away from bright and damp places.

SERVICING





Any questions regarding service and or operation is to be addressed to the store where the machine was purchased.

12. TABLE OF SEWING MATERIALS NEEDLES AND THREAD

	Thin material (crepe, georgette)	Medium to thick material (Serge, gabardine, etc.)	Thick material (thick denim)
<p>HA×1SP Needle HA×1T (705/130)</p> <p>(For home-use sewing machine)</p>	#11 (80)	#11 or #14 (80) or (90)	#14 (90)
Thread	<p>Polyestel (spun, filament)</p> <p>#60/2 Twisted thread ~ #80/2 twisted thread</p> <p>(#80/3 Twisted thread ~ #100/3 twisted thread)</p> <p>(Three-thread overedging stitch).</p>	<p>#60/2 Twisted thread</p> <p>(Three or four-thread overedging stitch).</p>	<p>#50/2 Twisted thread ~ 60/2 twisted thread</p> <p>(Three or four-thread overedging stitch).</p>
<p>Thread tension</p> <p>(Needle thread)</p>	Loose	Medium	Tight
	(Set the balance of looper tensions weak).		
<p>Overedging width</p> <p>(Between left needle and edge)</p>	4.2 ~ 4.5mm	4.2 ~ 4.5mm	4.5 ~ 5mm
Stitch length	2 ~ 2.5mm	2.5 ~ 3mm	2.5 ~ 3mm

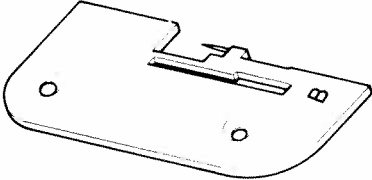
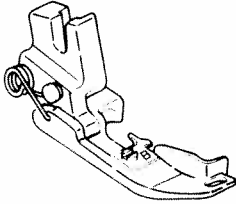
Use ball point needles for Man-Made fibers

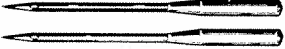
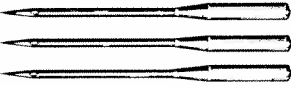
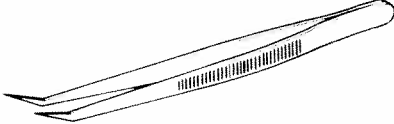
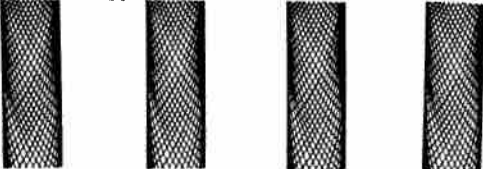
13. ACCESSORIES

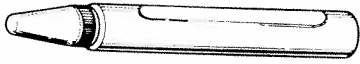
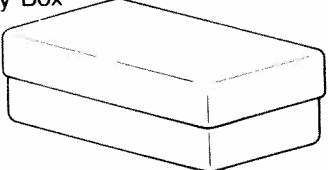
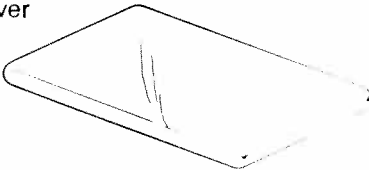
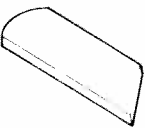
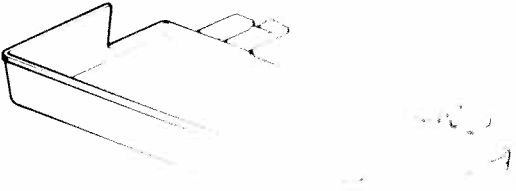
<p>Needle plate for rolled hemming</p> 	<p>Presser foot for rolled hemming</p> 
<p>Screw drivers</p> 	
<p>Needles</p> <p>HAx1SP HAx1T 705/130</p>  <p>#11...2 (80)</p>  <p>#14...3 (90)</p>	<p>Tweezers</p> 
<p>Net</p> 	<p>Spool Adapter</p> 
<p>Cleaning brush</p> 	<p>Oiler</p> 
<p>Accessory Box</p> 	<p>Vinyl cover</p> 
<p>Lower knife</p> 	<p>Waste tray</p> 

14. SPECIFICATIONS

Number of threads	4 Threads (3 threads)
Number of needles	2 Needles (1 needle)
Needles	Standard HA×1SP or HA×1T (705/130) #11 (80)
Width between two needles	2mm
Overedge width Size of bight	Standard 4.5mm (Range 4.2 ~ 6mm)
Stitch length	1 ~ 5mm
Differential feed ratio	1:0.7 ~ 2
Maximum sewing speed	1500 RPM
Machine dimensions	Width 300mm (Max. 330mm) Depth 220mm (Max. 220mm) Height 290mm (Max. 330mm ~ 570mm)
Weight	8.1 kg

Free Manuals Download Website

<http://myh66.com>

<http://usermanuals.us>

<http://www.somanuals.com>

<http://www.4manuals.cc>

<http://www.manual-lib.com>

<http://www.404manual.com>

<http://www.luxmanual.com>

<http://aubethermostatmanual.com>

Golf course search by state

<http://golfingnear.com>

Email search by domain

<http://emailbydomain.com>

Auto manuals search

<http://auto.somanuals.com>

TV manuals search

<http://tv.somanuals.com>