

SUPREME ULTRA HIGH SPEED BURNISHER



P1700-20 SERVICE MANUAL AND PARTS LIST

INSPECTION

Carefully unpack and inspect your machine for shipping damage. Each unit is operated and thoroughly inspected before shipment, and any damage is the responsibility of the delivering carrier who should be notified immediately.

ELECTRICAL

This rotary polisher is designed to operate on a standard 15 amp, 115 volt, 60 hz, AC household current. Check that the voltage shown on the serial number plate is suitable for the supply available. Voltages below 105 volts or above 125 volts could cause damage to the motor.

WARNING: To avoid electric shock do not expose to rain. Store indoors.

GROUNDING INSTRUCTIONS

To protect the operator from electrical shock, this machine must be grounded while in use. The machine is equipped with an approved, three-conductor power cord and three-prong grounding type plug to fit the proper grounding type receptacle. The P1700-20 is equipped with a 14-3, 80 foot power cord.

OPERATION

1. Plug machine into the power supply and check that the red indicator light (located on top of switch housing) is on.
2. You will notice three control levers located at the top of the handle. The two smaller ones directly beneath the handle grips control the on/off switches. From the operator's position, the longer lever on the right is used for adjusting/locking the handle in position.

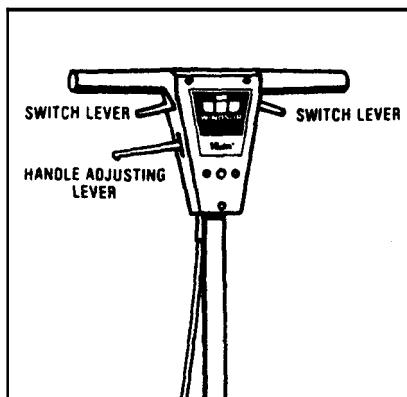

3. With the handle locked in the upright position, tilt the machine back until the handle is resting on the floor exposing the High-Flex drive-pad. Install the proper high speed buffing pad using the centering/locking pad holder to retain pad.
4. With the pad properly installed, return machine to the upright position.

CAUTION: To prevent possible damage to the pad or pad driver, remove buffing pad from machine when not in use.

5. Adjust front caster: For thin pads turn caster adjusting knob counter-clockwise to lower machine. For thick pads turn clockwise to raise machine.

NOTE: When pad pressure is properly set, the machine will start instantly. If too much pressure is applied, an overload of motor will exist causing circuit breaker to trip.

6. Pull up on the adjusting lever and lower the handle to a comfortable working height. Release adjusting lever to lock handle in place.

NOTE: A safety switch mounted in the handle will not allow machine to run until handle is lowered to the operating position.

For best results, the Supreme High-Speed Burnisher should be operated in a straight line — forward and reverse — not side to side as you would a low speed polisher.

The floor polisher is equipped with a circuit breaker. The action of the circuit breaker is entirely dependent upon the loading of the brush drive motor and will only trip under excessive overload conditions. If the circuit breaker should trip, it can be reset after 20 seconds by pressing the reset button on the right hand side of the motor housing.

NOTE: The operator should correct the cause of overloading before proceeding. The most common cause is an excessively soiled pad which should be turned over, cleaned or replaced.

SERVICING

A full service inspection involves the inspection and testing of all items which affect operator safety, items which may require adjustment from time to time, and items subject to wear which may require replacement in order to prevent a breakdown.

Motor: The motor is totally enclosed, capacitor start, capacitor run with circuit breaker protection.

All ball bearings are sealed and have enough lubricant for the life of the machine.

Remove motor cover occasionally and blow dust and lint from motor housing.

Wheels: Periodically remove wheels and add silicone lubricant to axle.

Motor Removal:

1. Remove high-flex drive pad (4) screws.
2. Remove brush cover (6) screws.
3. Release tension on belt tension spring.
4. Remove motor mounting bolts (3).

Belt Replacement/Adjustment:

1. Remove high-flex drive pad.
2. Remove brush cover.
3. Release tension on belt tension spring.
4. Loosen nuts on motor mounting studs — 4 or 5 turns.
5. Install new belt and readjust belt tension as shown:

MOTOR MOUNTING AND BELT TENSION ADJUSTMENTS

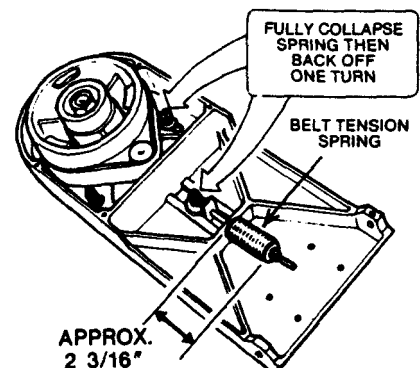

The trouble shooting guides on inside and back cover have been categorized to assist you in locating and servicing problems that could occur during the life of the High-Speed Burnisher.

SUPREME ULTRA HIGH-SPEED BURNISHER P1700-20

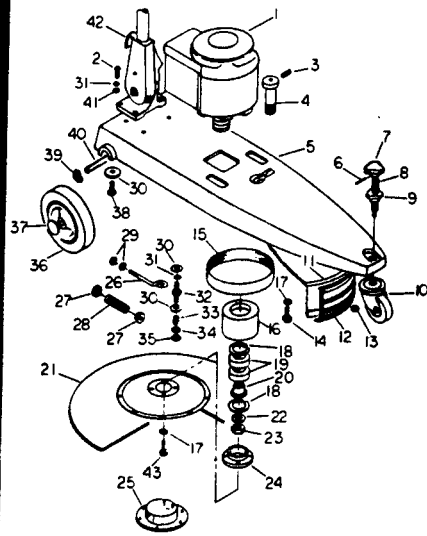

MOTOR ASSEMBLY P1700-20

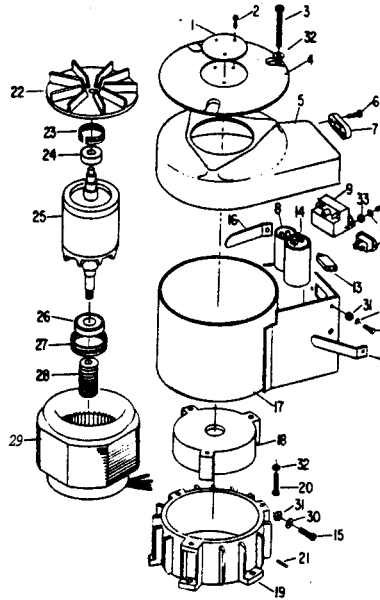

HANDLE/PIVOT ASSEMBLY

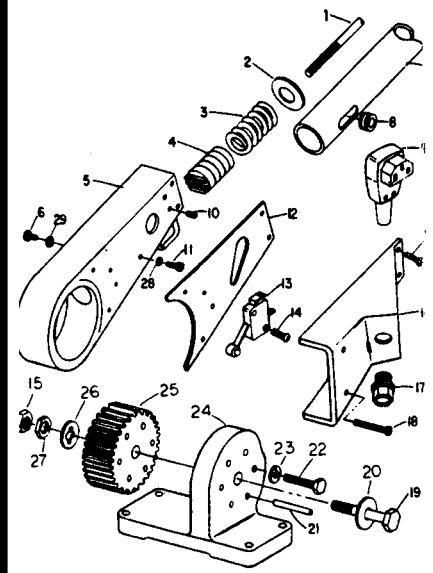

KEY	PART NO.	DESCRIPTION
1	53117	Motor Asm., (See Motor Brkdwn.)
2	70135	Screw, M8 x 30 HHMS
3	70181	Screw, M10 x 20 SHSS
4	14233	Bolt, Pulley - Through Hole
5	08034	Casting, Base
6	66048	Pin, 1/8" x 1" Selock
7	48015	Knob, Caster Adjusting
8	73174	Stem, Caster Adjusting
9	57076	Nut, Aluminum Lock
10	18018	Caster, 75mm Wheel
11	27222	Cover, Deep Brush 550 x 75mm
12	14234	Bumper, Deep Ring 1660mm
13	57077	Nut, M10 Hex
14	70183	Screw, M6 x 15 HHMS
15	11014	Belt, Drive 190 J 12
16	64030	Pulley, 80mm
17	87062	Washer, M6 Lock
18	67038	Spring, 52mm Internal
19	09016	Bearing - 25mm
20	73171	Sieve, Bearing
21	66066	Pad Driver Asm., Complete
22	87044	Washer, M20 S.P.
23	57050	Nut, M20 Hex
24	34109	Flange, Pad Driver
25	67069	Retainer, Pad
26	14139	Eyebolt, Cranked
27	51030	Locator, Spring
28	73106	Spring
29	57053	Nut, M6
30	87041	Washer, 30 x 9 x 2.5mm
31	87047	Washer, M8 S.P.
32	73107	Stud, Motor
33	73118	Spring
34	87049	Washer, M8 Plain
35	57052	Nut, M8 Lock
36	89039	Wheel, 250mm
37	27154	Cap, 1/2" Star
38	70184	Screw, M8 x 25 Hex

KEY	PART NO.	DESCRIPTION
1		Name Plate
2	70144	Screw, #4 x 3/16" S.T.
3	70178	Screw, M6 x 60mm PH
4	27160	Cover, Air Inlet
5	27161	Cover, Motor
6	70142	Screw, M4 x 10 P.H.
7	67047	Retainer, Power Cord Plug
8	27143	Capacitor, 320/400 MFD Capacitor
9	67039	Relay, Type 2CR4 - 258
10	70140	Screw, M3 x 10 P.H.
11	73104	Socket, Inlet
12	87061	Washer, M3 Lock
13	27204	Breaker, Circuit 12A
14	27219	Capacitor, 20 MFD 400V Run
15	70141	Screw, M4 x 10 Brass
16	27146	Clip, Spring
17	41067	Housing, Motor
18	27162	Casting, Motor Top
19	27163	Casting, Motor Bottom
20	70147	Screw, M6 x 25mm
21	66048	Pin, 1/8" x 1" Selock
22	34073	Fan, Motor Cooling
23	67044	Ring, 40mm Star
24	09015	Bearing, LJ 17
25	67040	Rotor Assembly, 115V
26	09016	Bearing, LJ 25
27	67045	Ring, 52mm Star
28	57061	Nut, M3 Hex
29	73105	Stator Assembly, 115V
39	87046	Washer, Wave
40	03025	Axle, P1700-20
41	57054	Nut, M8
42	66067	Handle Pivot Asm., (See Handle Breakdown)
43	70185	Screw, M6 x 30 PHMS

KEY	PART NO.	DESCRIPTION
1	67046	Rod, Handle Adj.
2	87053	Washer, Selector Spring
3	73122	Spring, Selector
4	73123	Selector, Handle Position
5	27165	Casting, Selector Housing
6	70142	Screw, M4 x 12 PH
7	78073	Tube, Handle
8	36025	Grommet 12mm
9	66044	Cord End, Angled Connector
10	70153	Screw, M8 x 15mm Socket Set
11	70141	Screw, M4 x 10 Brass PH
12	35050	Gasket
13	72031	Switch, Safety
14	70179	Screw, M3 x 16 PH
15	57059	Nut, M12 Dome
16	27166	Cover, Pivot Switch
17	73108	Strain Relief, Handle Cable
18	70180	Screw, M4 x 30 PH
19	14159	Bolt, M12 x 70
20	87045	Washer, M12 Plain Washer
21	66050	Pin, 1/4" x 1 3/4"
22	70156	Screw, M8 x 40 Hex
23	87047	Washer, M8 Lock
24	14158	Bracket, Pivot
25	36026	Gear, Selector
26	87059	Washer
27	57060	Nut, Half Hex
1	87058	Washer, M4 Flat
1	87057	Washer, M4 Shakeproof

HANDLE/SWITCHBOX ASSEMBLY

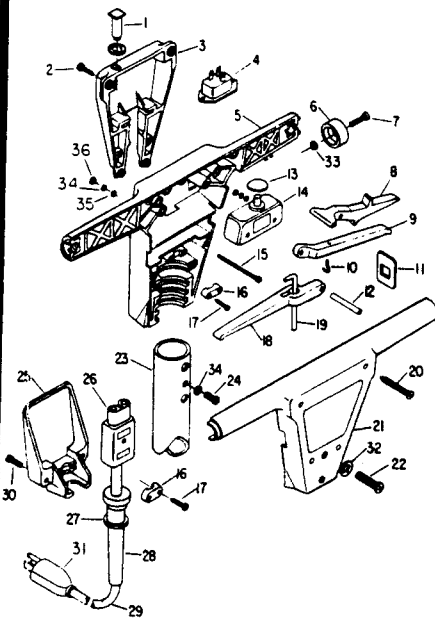

SD1 & TD2 OPTIONAL

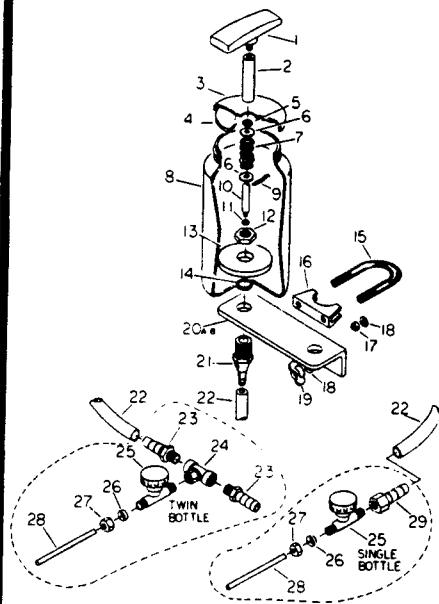

P1700-20 WIRING DIAGRAM

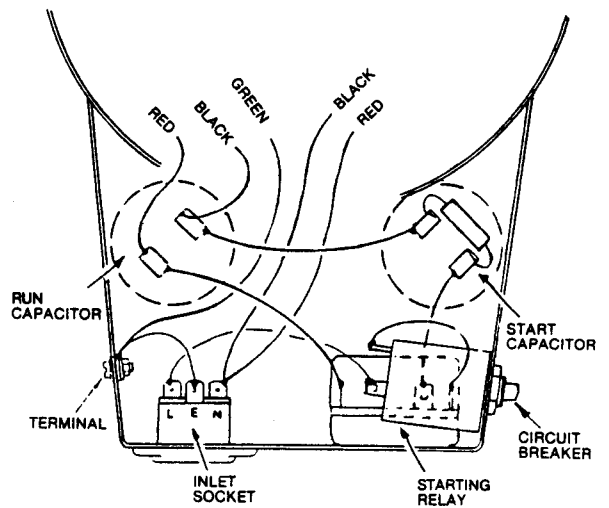

KEY	PART NO.	DESCRIPTION
1	51026	Light, 115V Neon w/Ret Ring
2	70148	Screw, #10 x 20mm St. PH
3	41064	Housing, Handle Cord Plug
4	73104	Socket, Cable Inlet
5	41063	Housing, Rear Handle
6	27164	Cap, Handle End
7	70149	Screw, M6 x 20 PH
8	51027	Lever, Handle Switch White
9	51028	Lever, Solution Release White
10	41068	Hook, Fluid Lever
11	62073	Plate, Lever
12	66049	Pin, Lever Pivot
13	27142	Cap, Switch Lever Spring
14	72024	Switch, SP ON/OFF
15	70150	Screw, M4 x 60 PH
16	20034	Clamp, Cable
17	70151	Screw, #8 x 5/8" ST
18	51029	Lever, Handle Release White
19	67046	Rod, Handle Adj. Pull
20	70152	Screw, #10 x 1 1/2" ST
21	41062	Housing, Front Handle
22	70149	Screw, M6 x 20 FH
23	78073	Tube, Handle
24	70141	Screw, M4 x 10 BR PH
25	27141	Cover, Cord Handle Plug
26	26023	Cord End, Polisher Handle
27	87052	Washer, 22 x 17 x 2.5mm Fiber
28	73121	Strain Relief, Polisher Handle
29	23082	Cord Assembly, 80 feet 14/3
30	70142	Screw, M4 x 10 PH
31	26006	Cord End
32	87055	Washer, M6 Shakeproof
33	57053	Nut, M6 Hex
34	87057	Washer, M4 Shakeproof
35	87058	Washer, M4 Flat
36	57062	Nut, M4 Hex

KEY	PART NO.	DESCRIPTION
1	48014	Knob, M8 Male Pull
2	67067	Rod, Pull Extension
3	27221	Cap, Bottle
4	73172	Seal, Cap
5	59015	O-Ring 7.6 ID x 3.5mm
6	87070	Washer, M8 Brass
7	73173	Spring, Stainless Steel
8	14225	Bottle, Plastic 1.5 Litre
9	66061	Pin, Brass Cotter 3/32" x 1/2"
10	67068	Rod, Pull
11	59016	O-Ring 4.2 ID x 1.8mm
12	57073	Nut, 3/8" BSP Brass Hex
13	87071	Washer, Nylon
14	59017	O-Ring 15.5 ID x 3.5mm
15	14226	Bolt, U
16	14227	Bracket, Clamp
17	57053	Nut, M6 Hex
18	87055	Washer, M6 Lock
19	57074	Nut, M6 Dome
20A	14228	Bracket, Twin Bottle Support
20B	14229	Bracket, Single Bottle Support
21	14230	Body, Valve
22	78095	Tube, 5/16" ID Plastic (4m)
23	40025	Hosebarb, 5/16" HB x 1/8" BSP Male
24	78096	Tee, 1/8" BSP
25	84043	Valve, Control
26	34108	Ferrule, 3/16" O.D.
27	57075	Nut, 1/8" BSP - 3/16" O.D. Tube
28	78097	Tube, 3/16" O.D. Brass (100mm)
29	40026	Hosebarb, FPT x 5/16" HB

TROUBLE SHOOTING HANDLE UNIT

SYMPTOM	FAULT	TEST	REMEDY
Excessive side play	Pivot bolt loose.	Check for minimal side play at handle switch box.	Adjust pivot bolt (No. 24 pivot asm.) and retighten dome nut.
Stiff when changing position	Pivot bolt tight.		
Release lever stiff - will not release handle	Lever adjustment Seized or stiff position selector	Check lever free play - 3mm max at lever tip. Check lever for full movement at switch box.	Adjust pullrod inside switch box. Remove selector keyway screw and inject release oil.
High amps, no amps, blowing fuses, tripping (only if handle mounted)	Wired incorrectly Faulty components or wiring.	Remove brush from machine and plug supply cable directly into motor. CAUTION motor will start up on plugging in.	Check all handle unit components and wiring for continuity, shorts or damage.
Ground leakage trip, flash test fail	Wiring or components wet, dirty or damaged.	Pull out motor plug - retest and flash test (1.5 kv) each component to ground.	Clean up and dry out - if fault persists replace component.
Motor runs, no red light	Faulty neon	Check wiring connections to neon	Replace.

TROUBLE SHOOTING MOTOR ASSEMBLY

SYMPTOM	FAULT	TEST	REMEDY
Motor relay	Loose cooling fan Motor mounting loose	Inspection. "Feel" vibration at motor/base casting.	Retighten or repin Tighten or adjust motor mounting bolts.
No start, no amps	Bearings worn/damaged.	Turn motor by hand, inspect	Replace bearings.
	Wired incorrectly	Check wiring	Reconnect.
	Wiring open circuit	Check continuity.	Replace.
High amps, tripping/blowing fuses, no/poor start	Circuit breaker will not reset	Check continuity.	Replace.
	Relay open circuit.		Replace
	Wrong supply voltage	Check name plate.	...
Centrifugal switch/relay flutter	Bearings stiff or seized.	Turn motor by hand	Replace bearings.
	Wired incorrectly	Check wiring	Reconnect.
	Run capacitor start capacitor, start relay.	Test by substitution - ensure that the correct type is fitted.	Replace
Ground leakage trip, flash test fail	Centrifugal switch free movement of balance	Inspect contacts, ensure free movement of balance weights, check rotor switch, position of shaft.	Replace
	Stator unit	Check continuity, flash test (1.5 kv) to ground and between windings.	Replace
Ground leakage trip, flash test fail	Wired incorrectly.	Check wiring.	Reconnect.
	Wiring, windings or components wet, dirty or damaged.	Inspect and flash test (1.5 kv) each component to ground.	Clean up and dry out - if fault persists replace component.

GENERAL User serviceable faults			WINDSOR LIMITED WARRANTY
SYMPTOM	FAULT	REMEDY	
Red light will not come on or goes out when trying to start	Not plugged in, not switched on	Plug in and switch on	<p>WINDSOR warrants to the original purchaser/user for a period of one year from date of purchase that this Rotary Floor Machine is free from defects in workmanship and materials, under normal use and service, and when operated and maintained in accordance with Windsor's service and operating instructions. This warranty does not apply to normal wear items such as electrical cable, relays, capacitors, rubber parts and switches. During this one year period Windsor will replace or repair defective parts covered by this warranty when the machine is delivered either to the factory, Englewood, Colorado or to an Authorized Windsor Service Center. Transportation Costs are to be prepaid by the original purchaser/user.</p> <p>EXTENDED WARRANTY</p> <p>In addition to the above warranty, the following will apply</p> <ol style="list-style-type: none"> 1 In the event of failure from normal usage during the useful life of the machine of the main 'on/off' switch located in the machine handle switch housing, WINDSOR will replace or repair such switch free of cost except for labor and transportation charges which must be borne by the original purchaser. 2 For a period of three years after purchase WINDSOR will, without charge, replace or repair any motor that fails as a result of defects during normal service and usage except for normal wear items as described above and for transportation charges to and from the Windsor factory which must be prepaid by the original purchaser. <p>This warranty is in lieu of all other warranties, expressed or implied, and releases WINDSOR from all other obligations and liabilities. It is applicable only in the U S A and Canada, and is extended only to the original user/purchaser of this product.</p> <p>WINDSOR is not responsible for costs for repairs performed by other persons unless they have been specifically authorized in advance and in writing by WINDSOR. This warranty does not apply to damage from transportation alterations by unauthorized persons, misuse or abuse of the equipment, use of noncompatible chemicals or damage or loss of income due to malfunctioning of the product.</p>
	Faulty plug connections fuse blown or wrong fuse fitted	Open plug and inspect connections & cable restraint — fit a new fuse	
Red light on will not start	Faulty supply cable	Check by substitution	
	Wrong supply voltage	Check name plate.	
	Handle not in operating position	Lower handle	
Poor start/run trips circuit breaker or blows fuses	Handle assembly not plugged into motor	Plug handle assembly into motor	
	Circuit breaker tripped motor overloaded	Press red button to reset circuit breaker — wash or replace floor pad.	
Machine "wobbles" in use	Wrong supply voltage.	Check name Plate	
	Floor pad worn/not centered.	Check floor pad for uneven wear — center on the drive plate.	

TROUBLE SHOOTING BELT DRIVE TRAIN			
SYMPTOM	FAULT	TEST	REMEDY
Motor runs, bolt slip, no/poor drive, squeak on start, premature bolt wear	Belt too slack	Stall test machine with drive board glued or screwed to floor	Adjust belt tension correctly.
	Belt worn or broken	Inspection	Check pulley alignment before fitting new belt.
	Motor slide seized	Remove belt slacken mounting spring check for free movement.	Ensure free movement in guide slots over full length.
	Polished/greasy drive pulley	Inspection	Remove grease with solvent — emery pulley surface.
Belt runs off	Pulleys out of alignment — belt tension too high	Check pulley alignment	Re-align pulleys, refit drive belt, do not over tension.
High amps, tripping, blows fuses	Seized or stiff pulley bearings	Turn drive by hand — run motor with belt removed.	Replace bearings.
Noisy or "clicking" drive pulley	Bearings or housings worn.	Inspection	Replace — CAUTION The bearings are shrink fitted, heat the pulley before reassembly.



Free Manuals Download Website

<http://myh66.com>

<http://usermanuals.us>

<http://www.somanuals.com>

<http://www.4manuals.cc>

<http://www.manual-lib.com>

<http://www.404manual.com>

<http://www.luxmanual.com>

<http://aubethermostatmanual.com>

Golf course search by state

<http://golfingnear.com>

Email search by domain

<http://emailbydomain.com>

Auto manuals search

<http://auto.somanuals.com>

TV manuals search

<http://tv.somanuals.com>