



Wide Area Vacuum

Model: **NW**
 10125330

NWIFE
10125340

NUWAV AU
10125360

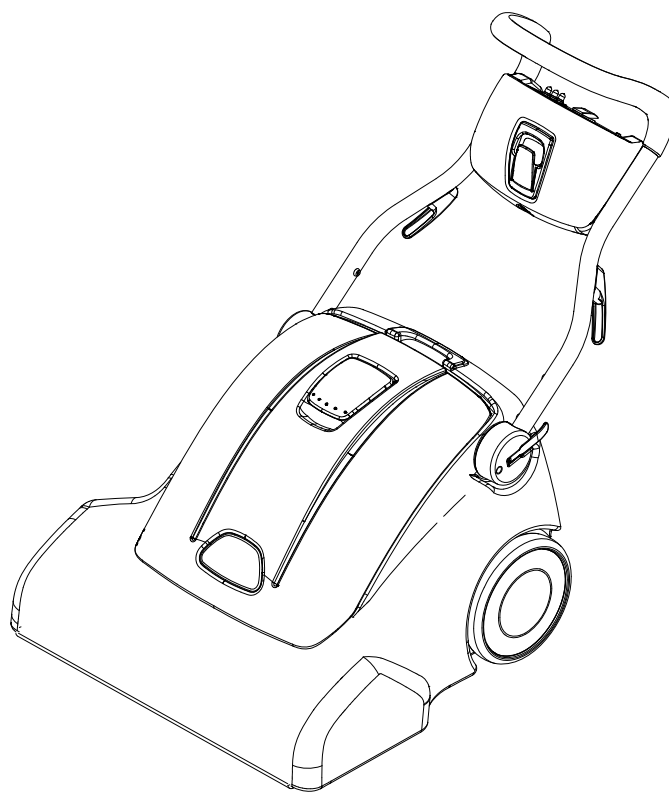

Operating Instructions (ENG)



MACHINE DATA LOG/OVERVIEW

Model: _____

Date of Purchase: _____

Serial Number: _____

Sales Representative: _____

Address: _____

Phone Number: _____

Copyright 2006 Windsor Industries, Printed in USA

OVERVIEW

The **NuWave™** is a electric motor powered, wide area vacuum intended for commercial use. The **NuWave™** brushes and vacuums debris from carpeted surfaces and stores the collected debris in vacuum bags.

TABLE OF CONTENTS

<i>Machine Data Log/Overview</i>	2
<i>Table of Contents</i>	3

HOW TO USE THIS MANUAL

<i>How to use this Manual</i>	1-1
-------------------------------------	-----

SAFETY

<i>Important Safety Instructions</i>	2-1
<i>Hazard Intensity Level</i>	2-2
<i>Grounding Instructions</i>	2-3
<i>Safety Label Location</i>	2-4

OPERATIONS

<i>Technical Specifications</i>	3-1
<i>Controls & Components</i>	3-2
<i>Set Up</i>	3-4
<i>Operation</i>	3-5
<i>Cleaning</i>	3-5

MAINTENANCE

<i>Maintenance-Components</i>	4-1
<i>Brush deck</i>	4-2
<i>Brush Replacement</i>	4-2
<i>Belt Replacement</i>	4-3
<i>Vacuum Motor(s)</i>	4-5
<i>Daily Maintenance</i>	4-6
<i>Regular/Periodic Maintenance</i>	4-6
<i>Service Schedule</i>	4-7

PARTS LIST

<i>Brush Deck</i>	5-1
<i>Brush Motor</i>	5-3
<i>Control Panel</i>	5-5
<i>Cover</i>	5-7
<i>Decal</i>	5-9
<i>Frame</i>	5-11
<i>Handle</i>	5-13
<i>Housing</i>	5-15
<i>Vacuum</i>	5-17
<i>Wiring Diagram</i>	5-19
<i>Suggested Spare Parts</i>	5-21
<i>Warranty</i>	5-22

OPTIONS

<i>Holster</i>	6-1
----------------------	-----

HOW TO USE THIS MANUAL

This manual contains the following sections:

- HOW TO USE THIS MANUAL
- SAFETY
- OPERATIONS
- MAINTENANCE
- PARTS LIST

The HOW TO USE THIS MANUAL section will tell you how to find important information for ordering correct repair parts.

Parts may be ordered from authorized Windsor dealers. When placing an order for parts, the machine model and machine serial number are important. Refer to the MACHINE DATA box which is filled out during the installation of your machine. The MACHINE DATA box is located on the inside of the front cover of this manual.

MODEL _____
DATE OF PURCHASE _____
SERIAL NUMBER _____
SALES REPRESENTATIVE # _____
DEALER NAME _____
OPERATIONS GUIDE NUMBER _____
PUBLISHED _____

Copyright 2007 Windsor Industries, Printed in USA

The model and serial number of your machine are located on the underside of the control panel.

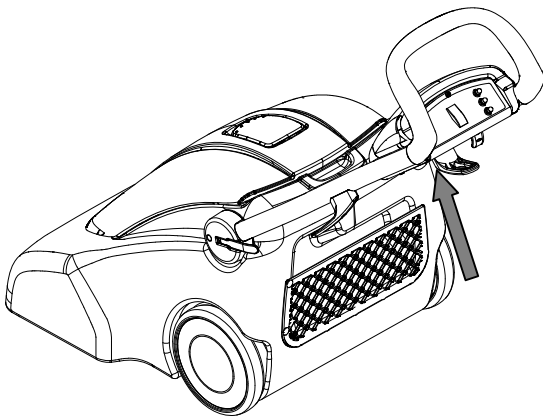

The SAFETY section contains important information regarding hazard or unsafe practices of the machine. Levels of hazards are identified that could result in product or personal injury, or severe injury resulting in death.

The OPERATIONS section is to familiarize the operator with the operation and function of the machine.

The MAINTENANCE section contains preventive maintenance to keep the machine and its components in good working condition. They are listed in this general order:

- Belt/Brush Motor
- Vac Motor and Filters
- Vac Motor Carbon Brushes
- Daily Maintenance
- Regular/Periodic Maintenance

The PARTS LIST section contains assembled parts illustrations and corresponding parts list. The parts lists include a number of columns of information:

- **REF** – column refers to the reference number on the parts illustration.
- **PART NO.** – column lists the part number for the part.
- **PRV NO.** – reference number.
- **QTY** – column lists the quantity of the part used in that area of the machine.
- **DESCRIPTION** – column is a brief description of the part.
- **SERIAL NO. FROM** – column indicates the first machine the part number is applicable to. When the machine design has changed, this column will indicate serial number of applicable machine. The main illustration shows the most current design of the machine. The boxed illustrations show older designs. If column has an asterisk (*), call manufacturer for serial number.
- **NOTES** – column for information not noted by the other columns.

NOTE: If a service or option kit is installed on your machine, be sure to keep the KIT INSTRUCTIONS which came with the kit. It contains replacement parts numbers needed for ordering future parts.

NOTE: The manual part number is located on the lower left corner of the front cover.

IMPORTANT SAFETY INSTRUCTIONS

When using an electrical appliance, basic precaution must always be followed, including the following:

READ ALL INSTRUCTIONS BEFORE USING THIS MACHINE.

 WARNING: To reduce the risk of fire, electric shock, or injury:

Use only indoors. Do not use outdoors or expose to rain.

Use only as described in this manual. Use only manufacturer's recommended components and attachments.

If the machine is **not working properly**, has been dropped, damaged, left outdoors, or dropped into water, return it to an authorized service center.

Do not operate the machine with any openings blocked. Keep openings free of debris that may reduce airflow.

This machine **is not** suitable for picking up hazardous dust.

Machine can cause a fire when operating near flammable vapors or materials. Do not operate this machine near flammable fluids, dust or vapors.

This machine is suitable for commercial use, for example in hotels, schools, hospitals, factories, shops and offices for more than normal housekeeping purposes.

Maintenance and repairs **must be done** by qualified personnel.

During operation, attention shall be paid to other persons, especially children.

The machine shall only be operated by instructed and authorized persons.

Do not handle the plug or machine with wet hands.

Do not unplug machine by pulling on cord. To unplug, grasp the plug, not the cord.

Do not use with damaged cord or plug. Follow all instructions in this manual concerning grounding the machine.

Do not pull or carry by cord, use cord as a handle, close a door on cord, or pull cord around sharp edges or corners.

Do not pull/run machine over cord. **Keep** cord away from heated surfaces.

Do not use to pick up flammable or combustible liquids, such as gasoline, or use in areas where they may be present.

Do not operate without dust bag and filter in place.

Do not pick up anything that is burning or smoking, such as cigarettes, matches, or hot ashes.

Connect to a **properly** grounded outlet. See Grounding Instructions.

SAVE THESE INSTRUCTIONS

HAZARD INTENSITY LEVEL

The following symbols are used throughout this guide as indicated in their descriptions:

HAZARD INTENSITY LEVEL

There are three levels of hazard intensity identified by signal words -**WARNING** and **CAUTION** and **FOR SAFETY**. The level of hazard intensity is determined by the following definitions:

WARNING:

WARNING - Hazards or unsafe practices which COULD result in severe personal injury or death.

CAUTION:

CAUTION - Hazards or unsafe practices which could result in minor personal injury or product or property damage.

FOR SAFETY: To Identify actions which must be followed for safe operation of equipment.

Report machine damage or faulty operation immediately. Do not use the machine if it is not in proper operating condition. Following is information that signals some potentially dangerous conditions to the operator or the equipment. Read this information carefully. Know when these conditions can exist. Locate all safety devices on the machine. Please take the necessary steps to train the machine operating personnel.

FOR SAFETY:

DO NOT OPERATE MACHINE:

Unless Trained and Authorized.

Unless Operation Guide is Read and understood.

In Flammable or Explosive areas.

In areas with possible falling objects.

WHEN SERVICING MACHINE:

Avoid moving parts. Do not wear loose clothing; jackets, shirts, or sleeves when working on the machine. Use Windsor approved replacement parts.

GROUNDING INSTRUCTIONS

THIS PRODUCT IS FOR COMMERCIAL USE ONLY.

ELECTRICAL:

The amp, hertz, and voltage are listed on the data label found on each machine. Using voltages above or below those indicated on the data label will cause serious damage to the motors.

EXTENSION CORDS:

If an extension cord is used, the wire size must be at least one size larger than the power cord on the machine, and must be limited to 50 feet (15.5m) in length.

GROUNDING INSTRUCTIONS:

This appliance must be grounded. If it should malfunction or break down, grounding provides a path of least resistance for electric current to reduce the risk of electric shock. This appliance is equipped with a cord having an equipment-grounding conductor and grounding plug. The plug must be inserted into an appropriate outlet that is properly installed and grounded in accordance with all local codes and ordinances.

120 VOLT MODELS:

This appliance is for use on a nominal 120-volt circuit, and has a grounded plug that looks like the plug in "Fig. A". A temporary adaptor that looks like the adaptor in "Fig. C" may be used to connect this plug to a 2-pole receptacle as shown in "Fig. B", if a properly grounded outlet is not available. The temporary adaptor should be used only until a properly grounded outlet (Fig. A) can be installed by a qualified electrician. The green colored rigid ear, lug, or wire extending from the adaptor must be connected to a permanent ground such as a properly grounded outlet box cover. Whenever the

adaptor is used, it must be held in place by a metal screw.



Improper connection of the equipment-grounding conductor can result in a risk of electric shock. Check with a qualified electrician or service person if you are in doubt as to whether the outlet is properly grounded. Do not modify the plug provided with the appliance - if it will not fit the outlet, have a proper outlet installed by a qualified electrician.

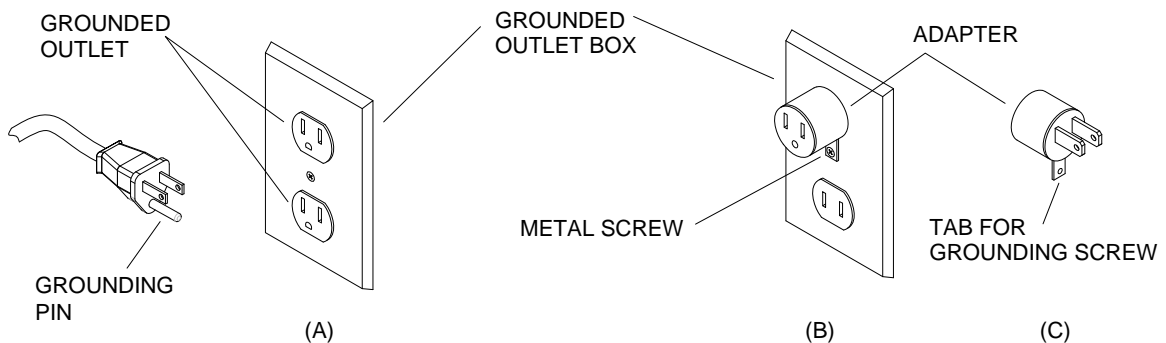

SAFETY

SAFETY LABEL LOCATION

The following WARNING LABEL(S) are found on your cleaning unit. These labels point out important Warnings and Cautions which should be followed at all times. Failure to follow warnings and cautions could result in fatality, personal injury to yourself and/or others, or property damage. Follow these instructions carefully! DO NOT remove these labels.

NOTE: If at any time the labels become illegible, promptly replace them.

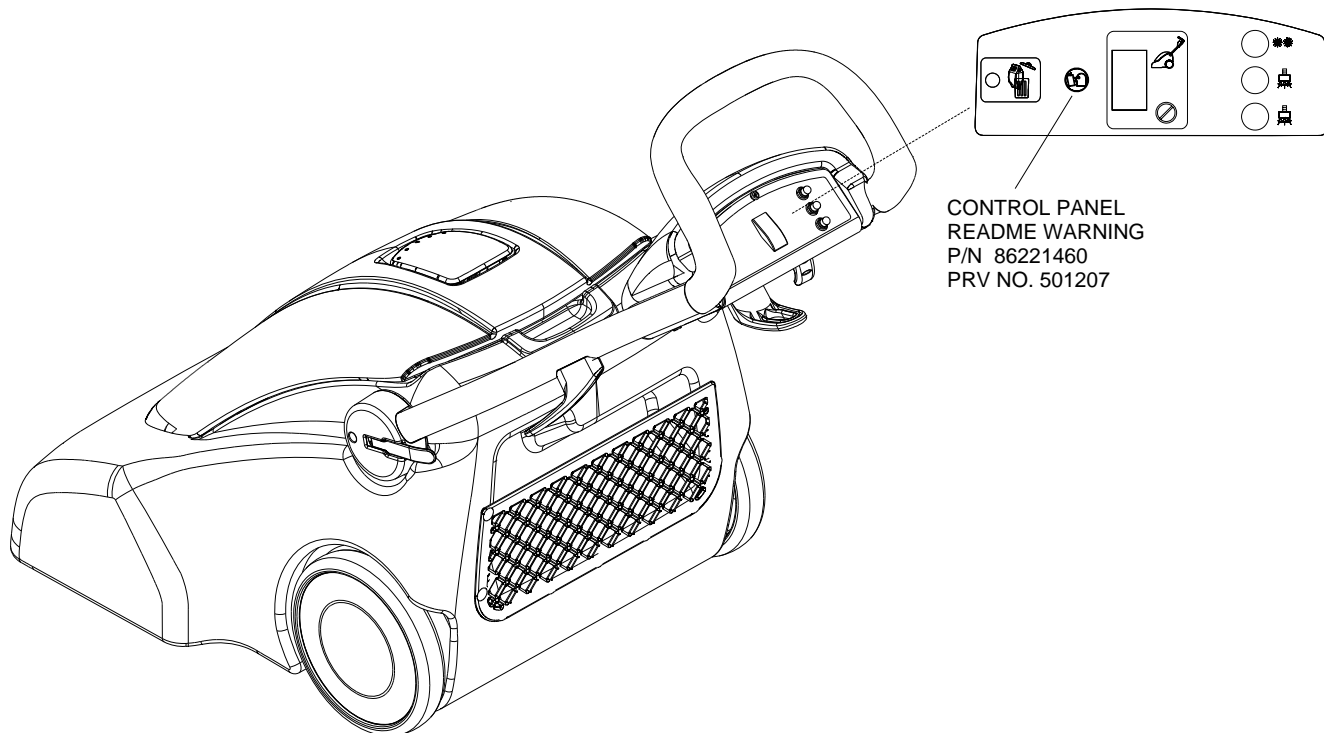

TECHNICAL SPECIFICATIONS

ITEM	DIMENSION/CAPACITY
Rated Amperage (120V)	15 AMPS
Rated Amperage (230V)	7.5 AMPS
Brush Motor	0.5 HP (373 W)
Bag Capacity	792 in ³ (13 L)
Brush	Two 25.5 in. (647mm) by 4 in. (10 mm) diameter
Brush Speed (120 V)	1550 RPM
Brush Speed (230 V)	1350 RPM
Maximum flow rate of machine	129 cfm (61 L/sec)
Maximum suction of machine	20 inches of water (4.97 kPa)
Weight Empty	151 lbs (68 kg)
Tires	9.75 in. (247mm) non-marking
Frame Construction	Powder coated steel

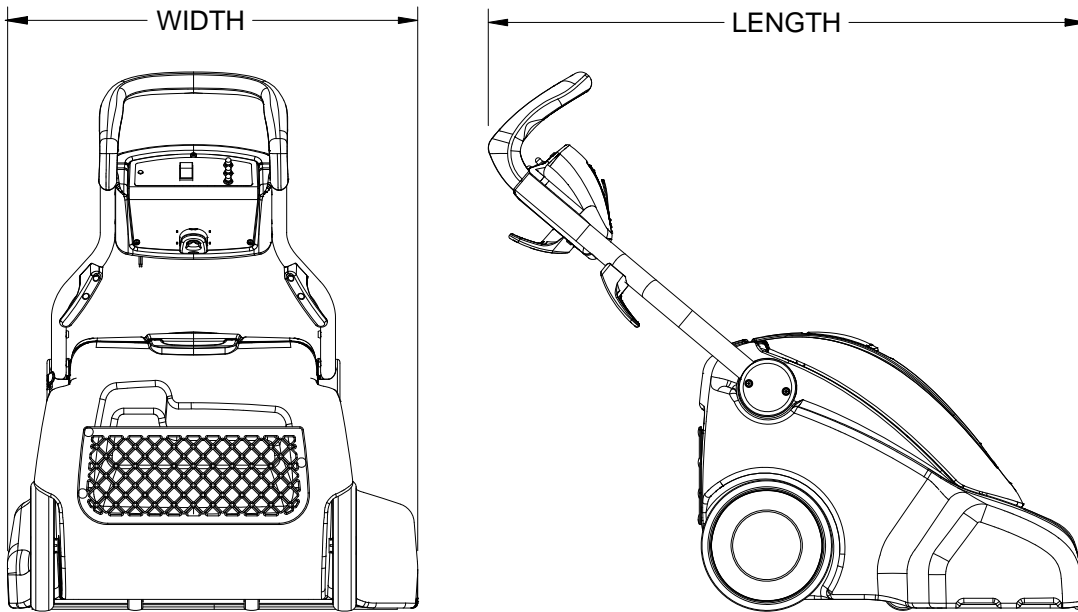

ITEM	MAXIMUM	STORAGE
Height	44 inches (1120 mm)	21 inches (530 mm)
Length	51.5 inches (1310 mm)	33 inches (840 mm)
Width	30.5 inches (770 mm)	30.5 inches (770 mm)

SPECIAL NOTES:

The sound pressure level at the operator's ear was measured to be 74dBA . This was a nearfield, broad-band measurement taken on a carpeted floor. This appliance contains no possible source of impact noise. The instantaneous sound pressure level is below 63 Pa.

The weighted root mean square acceleration at the operator's arms was measured to be below 2.5m/s² . This was a tri-axial, third-octave-band measurement made during normal operation on a composite tile floor. The measurement and related calculations were made in accordance with ANSI S3.34-1986.

This appliance is not intended for use by persons (including children) with reduced physical, sensory or mental capabilities, or lack of experience and knowledge, unless they have been given supervision or instruction concerning use of the appliance by a person responsible for their safety. Children should be supervised to ensure that they do not play with the appliance.

OPERATION

CONTROLS & COMPONENTS

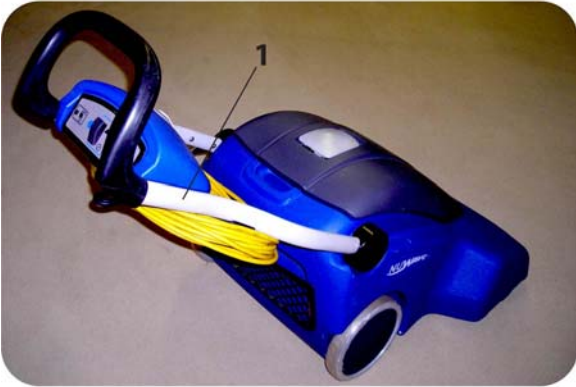

- 1. Main handle**
Adjust for operator comfort and storage.



- 2. Handle Adjustment Lever**
Adjusts for operator comfort and storage.

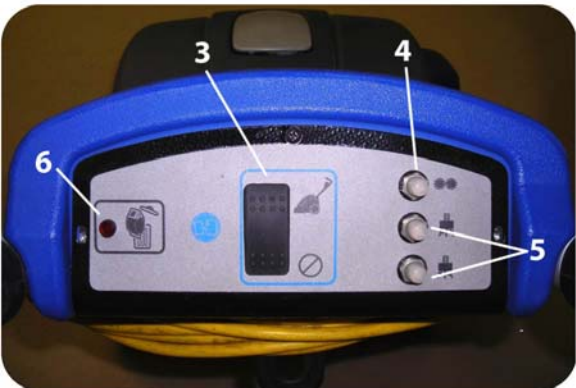

- 3. Vac on/off switch.**
Turns on and off vac motor.
- 4. Brush Motor Circuit Breaker**
Protects brush motor from overheating.
- 5. Vac Motor Circuit Breakers**
Protects the vac motors from overheating.
- 6. Bag full Indicator Light**
Indicates when filter bag requires replacement or a clog in the vacuum system ducting.

OPERATION

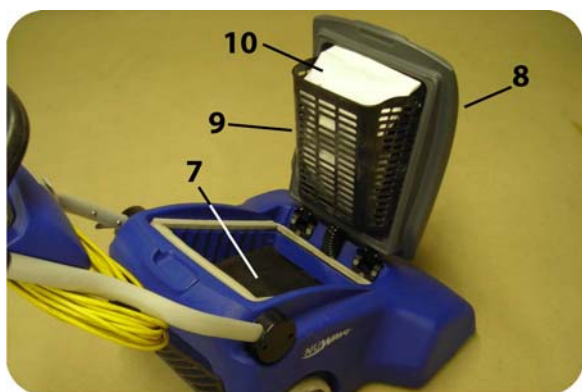

7. Intake Filter.

Filters intake air for extend vacuum motor life.

8. Filter Bag Cover

Raises to allow access to filter bag and vacuum motors.

9. Filter Bag Basket

Locates filter bag for maximum fill efficiency and easy changing.

10. Filter Bag

Lift out easily for service.

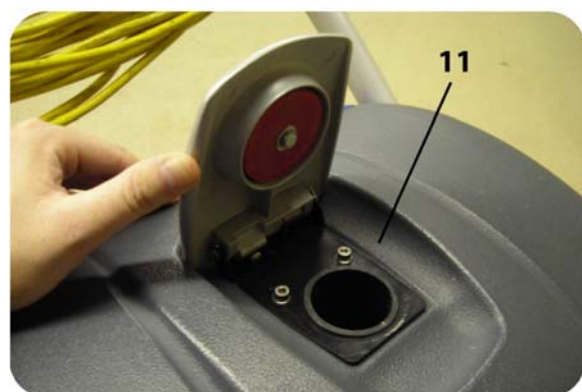

11. Accessory Port

Lift port to attach optional accessory hose. Brush motor will be deactivated during accessory use.

OPERATION

SET UP



1. Take machine out of storage position by lowering onto all four wheels.



2. Adjust handle to comfortable position at waist level by opening adjustment lever on left side of machine and moving handle. Lock back into position by closing adjustment lever.

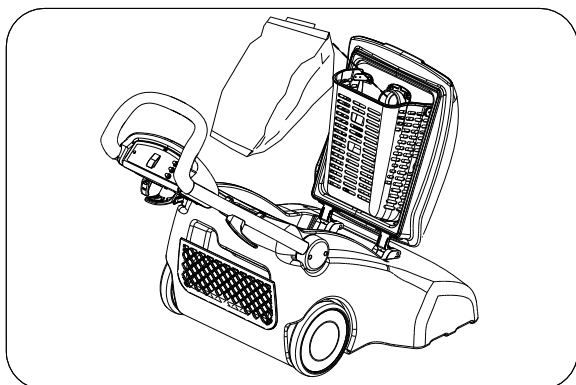

3. Install filter bag inside the main body by pushing the rubber collar over the chute.



CLEANING ROUTE

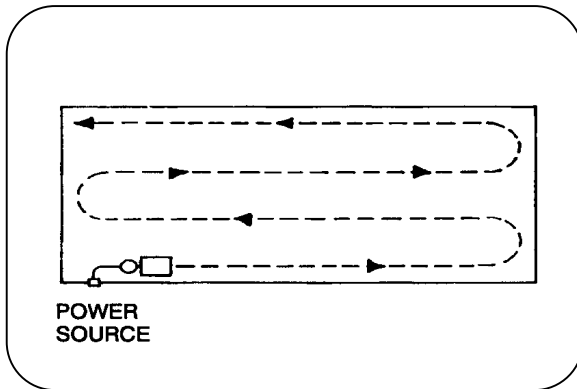

ACCESSORY PORT

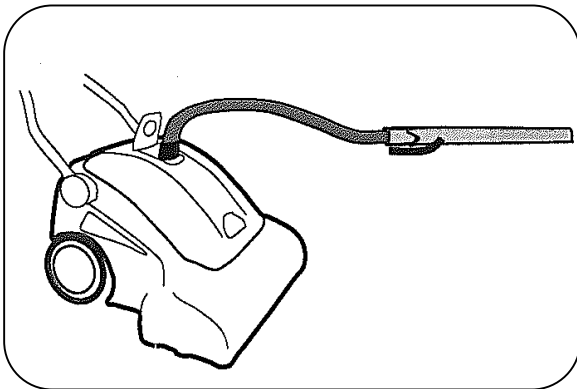

CORD HOOKS

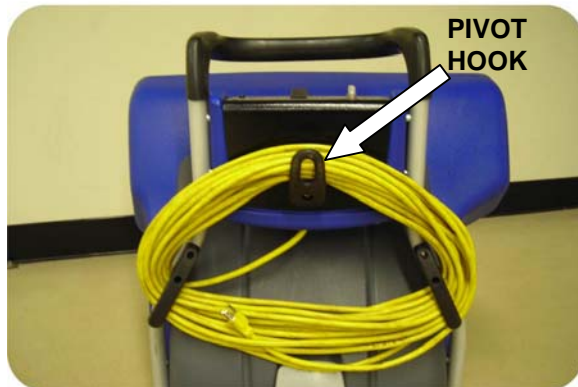

HOW IT OPERATES

This machine is a portable, easy to use wide area vacuum designed for use indoors, in a commercial or light industrial environment.

When operating as a carpet vacuum, soil is lifted from the carpet surface by two counter-rotating brushes and carried into a removable bag by the vacuum motors.

1. Large debris such as paper cups, plates, string, etc., should be picked up before starting the cleaning process.
2. Plan your cleaning route to work away from the electrical source. Move machine forward at a steady pace.

CLEANING

1. Adjust handle to comfortable position at waist level or higher.
2. Use your finger to depress the Vacuum switch on the control panel to activate the vacuum.
3. When using optional accessory tool, brushes will be deactivated when accessory port is lifted.

⚠ WARNING:

Keep machine moving while brush engaged. Damage to carpet could occur if not moving.

4. Move forward or backwards at a steady pace for thorough cleaning. Run machine more slowly over extremely soiled areas.
5. Use the right side of the machine for edge cleaning.
6. To keep the vacuum operating at maximum efficiency, check the filter bag regularly. Use the upper and lower access holes in basket to feel level of fullness. Empty when 1/2 to 3/4 full.
7. When finished vacuuming, coil the cord by wrapping around the three cord hooks provided on the handle tubes and control panel. The upper hook pivots for easy release of the cord.

MAINTENANCE

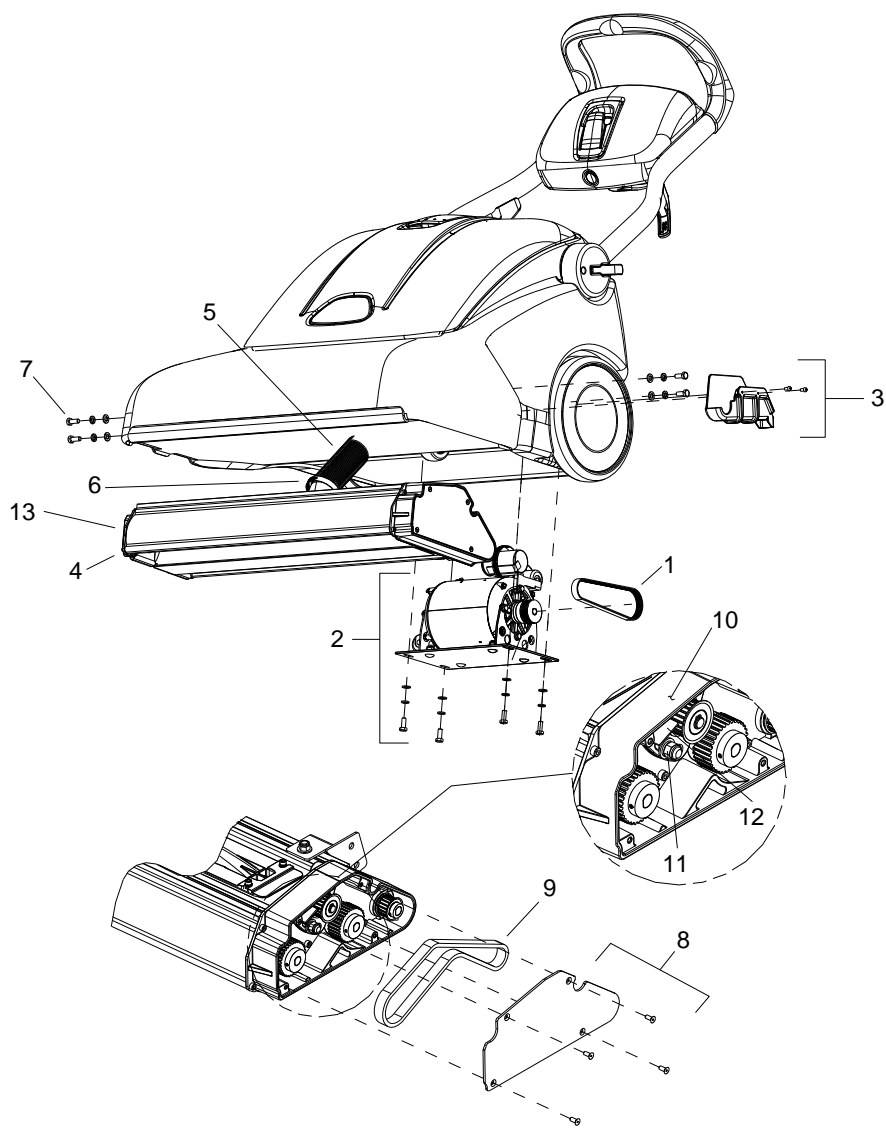

1. Primary Drive Belt
2. Brush Motor Assembly
3. Belt Guard
4. Brush Deck Assembly
5. Vacuum Hose
6. Hose Clamp
7. Brush Deck Mounting Bolts

8. Drive Housing Cover Plate
9. Secondary Timing Belt
10. Drive Housing
11. Belt Tensioning Nut
12. Belt Tensioning Bracket
13. Retaining Clips

NOTE: The following service items should be performed by an authorized service facility or authorized service personnel. All parts referred to in these instructions can be identified by using the parts lists and illustrations on the following pages.

! WARNING:

Remove machine power cord from electrical source before making any repairs or adjustments to the machine.

BRUSH DECK

The dual cylindrical brush deck is designed to efficiently extract dirt from the carpet. Please note the differences between the front/rear brushes. Installing them in reverse position will significantly reduce the performance of the machine. The brush part numbers are marked on drive ends of the brush core as follows:

8.621-612.0 (12543) - Front Brush

8.621-611.0 (12540) - Rear Brush

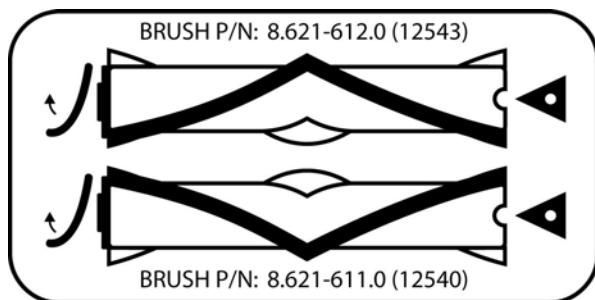

Brushes should be replaced as a set when bristle length wears to height of yellow PerformAlert™ bristles.

BRUSH REMOVAL

The brushes are removed from the right side of the machine.

1. Adjust handle into the vertical position and lock the cam lever. Tilt machine on it's back using handle to support it's position.
2. Pull out on the bottom of the retaining clip.
3. The brush assembly and end cap should drop down. Then pull the brush down far enough to clear the bottom of the housing.
4. Pull brush out with a rocking motion to free brush from drive hub.

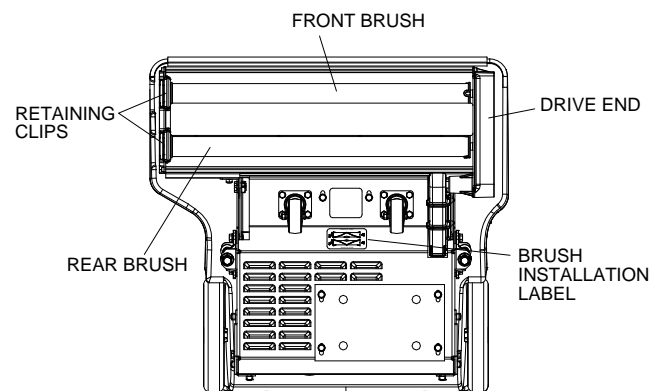

BRUSH REPLACEMENT

1. Make sure the brushes are in the correct position (front/rear) by following the brush installation label on the underside of the machine. Lift the drive side of the brush and push it onto drive hub until a positive stop is felt. The brush cannot be installed until the brush is fully seated on the drive hub.
2. Pull out on the bottom of the retaining clip.
3. Line up end cap with the flats to each side.
4. Slide brush up into retaining clip until it clicks in place.

MAINTENANCE

BELT REPLACEMENT

The primary drive belt and secondary belt should be replaced if they are damaged or broken. To determine if a belt is damaged or broken, there will be a noticeable drop in the performance of the machine or the brushes will not spin when the machine is turned on.

PRIMARY DRIVE BELT REPLACEMENT

The primary drive belt is removed from the under side of the machine.

- 1.** Unplug power cord.
- 2.** Adjust handle into vertical position and lock cam lever. Tilt machine on it's back using handle to support it's position.
- 3.** Remove belt guard by loosening the (2) mounting screws.
- 4.** Remove brush motor assembly by loosening the (4) mounting bolts.
- 5.** Remove damaged or broken belt from drive pulleys and replace with a new drive belt. Be sure the grooves in the drive belt match the grooves in the drive pulleys.
- 6.** Install brush motor assembly with new drive belt to the machine by using the (4) mounting bolts. With mounting bolts in place but not fully tightened, use weight of the brush motor assembly to apply proper tension to the drive belt. Once the belt is properly tensioned, fully tighten the mounting bolts.
- 7.** Attach belt guard to the frame by using the (2) mounting screws.
- 8.** Plug machine into a power supply and turn it on to assure the machine is running properly.

SECONDARY BELT REPLACEMENT

The secondary belt can be accessed from the under side of the machine.

1. Unplug power cord.
2. Adjust handle into the vertical position and lock the cam lever. Tilt machine on it's back using the handle to support it's position..
3. Remove belt guard by loosening the (2) mounting screws.
4. Loosen the 4 mounting bolts for brush motor assembly to relieve primary drive belt tension. Do not fully remove the (4) mounting bolts. Remove primary drive belt from the brush deck pulley.
5. Remove brush deck assembly by loosening the 4 mounting bolts that attach it to the linkage arms (2) bolts on the right side and (2) on the left side). With the brush deck assembly removed, detach vacuum hose from the nozzle by loosening hose clamp.
6. The secondary belt can now be accessed on the right side of brush deck assembly by removing the (4) screws that mount the drive housing cover/plate.
7. Loosen nut on the belt tensioning bracket and remove damaged/broken belt. Install new secondary belt in the same configuration.
8. Apply tension to belt by pressing thumb tab on belt tensioning bracket. Tighten the nut on belt tensioning bracket until proper tension is achieved. Test belt by spinning brushes. Brushes should spin easily without excessive friction.
9. Replace drive housing cover/plate, reattach the vacuum hose to nozzle, and reassemble brush deck to machine by using the (4) mounting bolts (2) on right side and (2) on left side.
10. Reattach primary drive belt to brush deck pulley making sure the grooves line up properly. Apply proper tension to primary drive belt and tighten the (4) mounting bolts on brush motor assembly. Reattach primary belt guard.
11. Plug machine into a power supply and turn it on to assure the machine is running properly.

MAINTENANCE

REMOVE VAC MOTOR AND FILTERS.

1. Unplug power cord.
2. Open cover.
3. Remove (6) screws from vacuum motor retaining plate.
4. Remove (8) screws from vac motor brackets, (4) each bracket.
5. Lift vacuum motors out of machine body.

VACUUM MOTOR CARBON BRUSHES REPLACEMENT

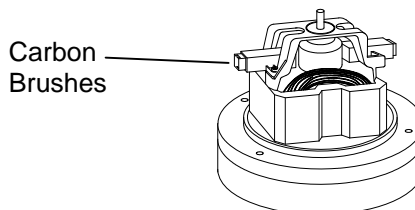

If armature commutator is grooved, extremely pitted or not concentric, the motor will need to be replaced or sent to a qualified service center.

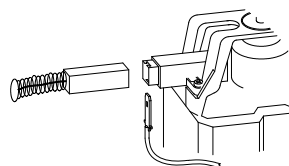

Important:

These brushes wear quicker as the length shortens due to increased heat. Spring inside brush housing will damage motor if brushes are allowed to wear away completely.

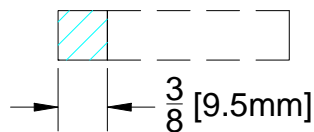

Periodically check the length of the carbon brushes. Replace both carbon brushes when either is less than 3/8" (9.5mm) long.

DAILY MAINTENANCE

- 1.** Unplug power cord.
- 2.** Shake down the contents of the bag daily.
- 3.** Check power cord for damaged or frayed insulation.
- 4.** Check for and remove any lint or debris around brush and brush housing.

REGULAR/PERIODIC MAINTENANCE

- 1.** Unplug power cord.
- 2.** Every 4 to 6 months remove wheels, clean axles, and apply a thin coat of silicone lubricant to axles.
- 3.** Inspect and clean vac motor filters.
- 4.** Periodically inspect all hoses, electrical cables, filters, gaskets and connections on your machine. Frayed or cracked hoses should be repaired or replaced to eliminate vacuum loss.
- 5.** The electrical cable must be well insulated, if the cable insulation is broken or frayed, repair or replace it immediately. Don't take chances with electrical fire or shock.

MAINTENANCE

SERVICE SCHEDULE

MAINTENANCE	DAILY	WEEKLY	MONTHLY	QUARTERLY
Check bag and replace if necessary	*			
Check filters and replace if necessary	*			
Check hoses for wear, blockages, or damage	*			
Inspect base for clogs	*			
Check vac nozzle for clogs; remove clogs with fingers (if appropriate)	*			
Check major gaskets for leakage	*			
Check brush-should be clean with no lint or strings attached	*			
Wind cord and store in upright position	*			
Check hoses for cracks or holes		*		
Check all cords and handles for damage or cracks; replace as necessary		*		
Check brushes for wear; replace if necessary		*		
Check brush strip for wear; replace if necessary		*		
Inspect and replace all filters including exhaust, intake			*	
Inspect, clean, and repair power head – including brush housing			*	
Check all bearings for fiber build-up and noise			*	
Check all gaskets for wear and leakage			*	
Check belts for wear; replace if necessary			*	
Check vac motor carbon brushes				*
Check for arcing and pitting on any electrical contacts; replace if found				*
Inspect and clean vac deck; check for dents and damage which would detrimentally effect vacuum and brush movement				*
Check overall performance of machine				*

NUWAVE

Parts List

86011370 NUWAVE 05/30/07

BRUSH DECK

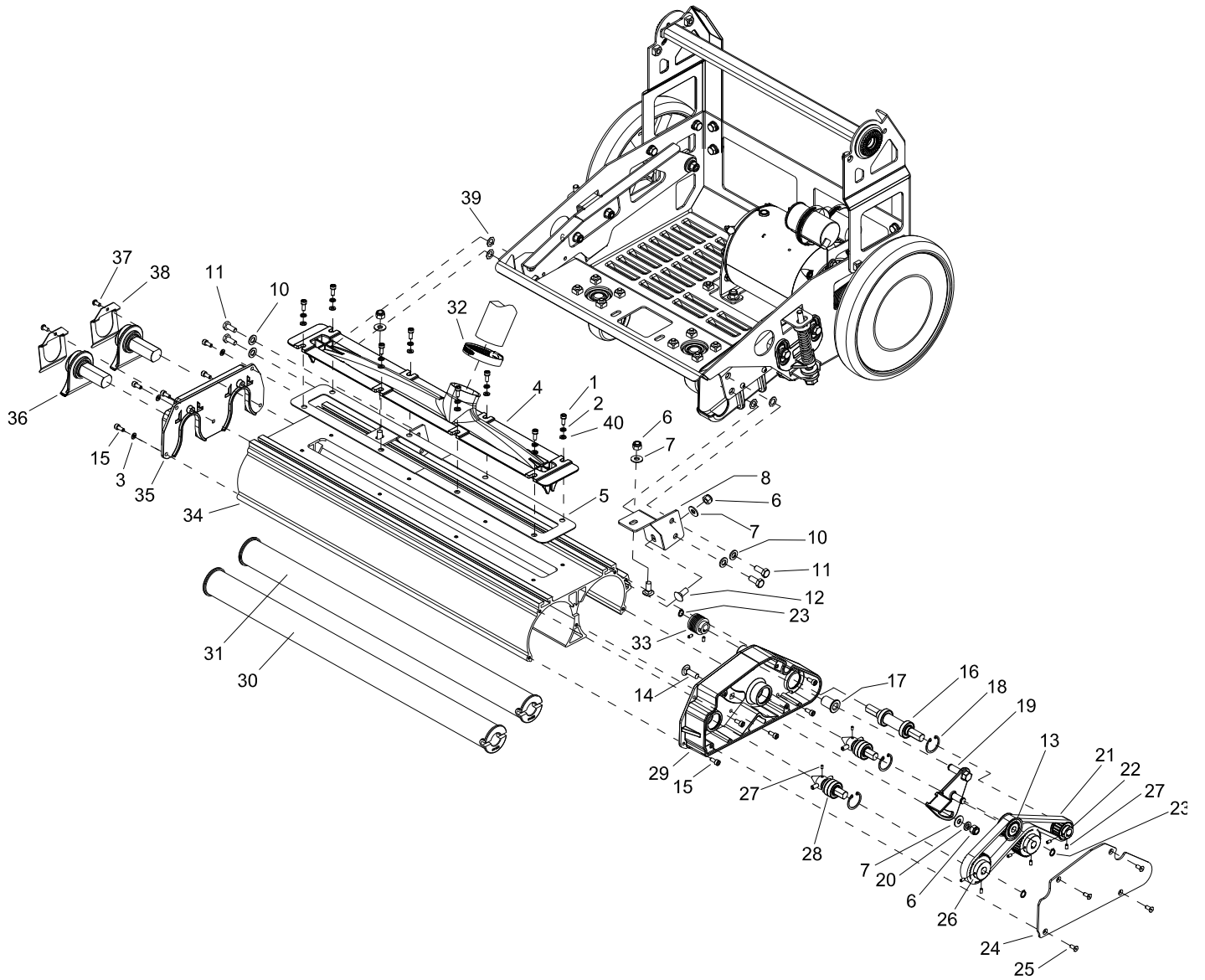

BRUSH DECK

REF	PART NO.	PRV NO.	QTY	DESCRIPTION	SERIAL NO. FROM	NOTES:
1	86293390	-	8	SCR, M5 X .8 X 15 SHCS GR 10.9 BLK		
2	86137300	87084	8	WASHER, M8 FLAT DIN125A PLT		
3	86173350	87515	5	WASHER, M5, FLAT, ISO7089, SS		
4	86290110	-	1	NOZZLE, VACUUM, DECK		
5	86218140	35366	2	GASKET, VAC NOZZLE		
6	86270830	57023	5	NUT, 5/16-18 HEX NYLOCK SS		
7	86010670	87029	5	WASHER, 5/16 FLAT SS		
8	86292460	-	2	WELMENT, DECK LEVELING BRKT		
9	OPEN	-	-	-		
10	86010720	87086	4	WASHER, M10 X 30 PLTD		
11	86295960	-	4	SCR, M10 X 20 HHMS GR 8.8 PLT		
12	86293380	-	4	SCR, 5/16-18 X 3/4 CARR GR 10.9		
13	86012780	-	1	PULLEY ASM, 5MM HTD 22T		
14	86277130	70795	1	SCR, 5/16 X 1.00 CARRAGE SS		
15	86293400	-	10	SCR, M5X12 SHCS GR 10.9 PLT		
16	86293200	-	1	ASSY, JACK SHAFT DRIVE		
17	86215230	09161	1	BEARING, BRONZE FLANGED		
18	86223520	67598	3	RING, 28MM INT SNAP PHOSPHATE		
19	86215530	140941	1	BRACKET, BELT TENSIONER		
20	86279130	87083	1	WASHER, 5/16 SPLIT LOCK PLTD		
21	86215310	11056	1	BELT, TIMING, 5MM X 15MM X 575		
22	86223310	64116	1	PULLEY, 5MM HTD, 18T, 12.7ID		
23	86223490	67468	2	RING, 10MM EXT SNAP, DIN 471		
24	86222890	620118	1	PLATE, BRUSH DRIVE COVER		
25	86172970	70911	4	SCR, M5X12, PHLP PHMS, ISO 7046, SS		
26	86223320	64117	2	PULLEY, 32T, 5MM HTD		
27	86223780	70896	10	SCR, M4X8, SET, ISO4029, CP, BLK		
28	86012790	-	2	ASSY, BRSH END CAP SHFT		
29	86219400	41554	1	HOUSING, BRUSH DRIVE		
30	86216120	12543	1	BRUSH, 25.5 X 4.0 OD, FRONT		
31	86216110	12540	1	BRUSH, 25.5 X 4.0 OD, REAR		
32	86216750	20098	1	CLAMP, WORM GEAR 40-64MM		
33	86291140	-	1	PULLEY, MICRO-V, 1.125 OD		
34	86217810	32061	1	EXTRUSION, DUAL BRUSH DECK		
35	86219410	41555	1	HOUSING, BRUSH RELEASE CLIP		
36	86293230	-	2	ASSY, BRSH END CAP SHFT		
37	86172980	70912	2	SCR, KA50X10, PT OHS, WN1412, PLTD		
38	86224630	730380	2	SPRING, BRUSH CLIP		
39	86295970	-	4	WASHER, M10 EXT STAR LOCK		
40	86173330	87513	8	WASHER, M5 FLAT, ISO7093, SS		

BRUSH MOTOR

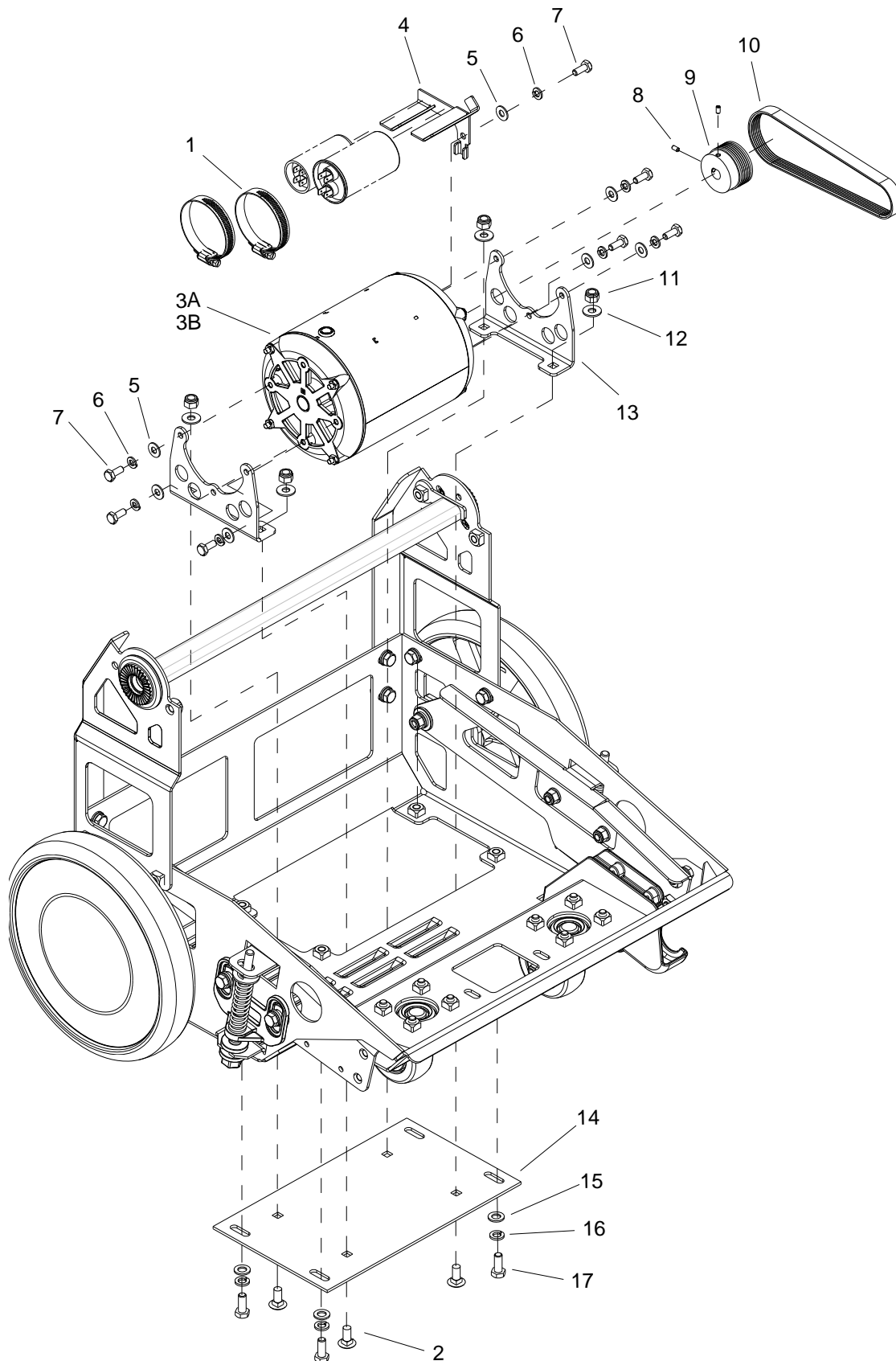

BRUSH MOTOR

REF	PART NO.	PRV NO.	QTY	DESCRIPTION	SERIAL NO. FROM	NOTES:
1	86216750	20098	2	CLAMP, WORM GEAR 40-64MM		
2	86293380	-	4	SCR, 5/16-18 X 3/4, CARR GR 10.9		
3A	86222120	53274	1	MOTOR, 115V, 0.5HP, INDUCTION		WITH CAPACITORS
3B	86222150	53279	1	MOTOR, 230V, .5HP, INDUCTION		
4	86012580	-	1	BRACKET, CAPACITOR, MOTOR MNT		
5	86010630	87013	7	WASHER, 1/4 ID X 5/8 OD SS		
6	86173340	87514	7	WASHER, SPLIT LOCK, 1/4, SS		
7	86293270	-	7	SCR, 1/4-20 X 5/8 HHCS 10.9		
8	86223780	70896	2	SCR, M4X8, ISO4029, CP, BLK		
9	86291150	-	1	PULLEY, MICRO-V, 1.80 OD		
10	86291380	-	1	BELT, 290J6, MICRO-V		
11	86270830	57023	4	NUT, 5/16-18 HEX NYLOCK SS		
12	86010670	87029	4	WASHER, 5/16 FLAT SS		
13	86215550	140970	2	BRACKET, MOTOR MOUNT		
14	86222900	620120	1	PLATE, MOTOR BASE		
15	86137280	87054	4	WASHER, M8 FLAT DIN125A PLT		
16	86137310	87098	4	WASHER, M8 SPLIT LOCK		
17	86274860	70311	4	SCR, M8X20 HHMS		

CONTROL PANEL

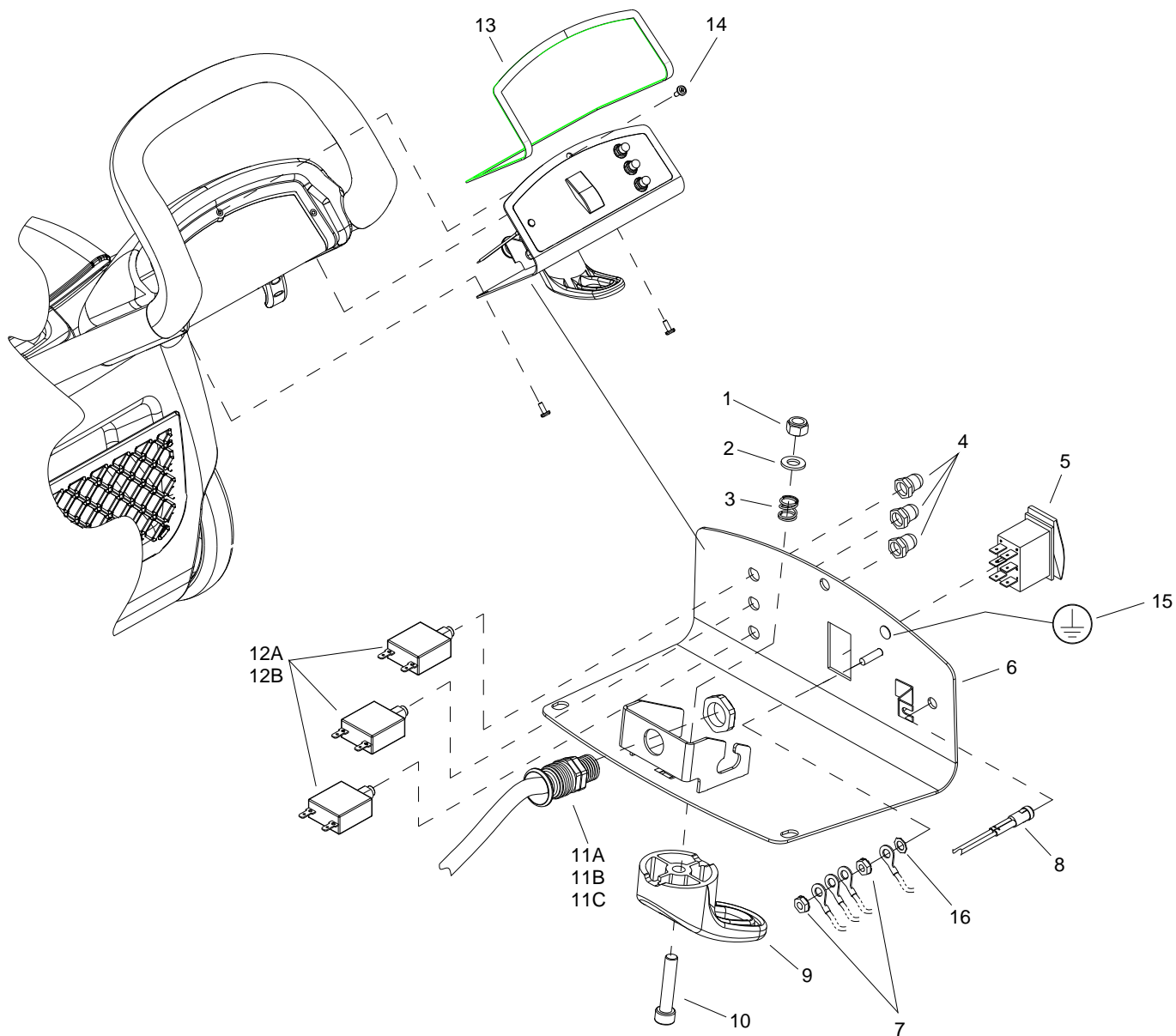

CONTROL PANEL

F	PART NO.	PRV NO.	QTY	DESCRIPTION	SERIAL NO. FROM	NOTES:
1	86172640	57507	1	NUT, M8, NYLOCK, ISO7040, SST		
2	86173300	87495	1	WASHER, M8, FLAT ISO7089, SST		
3	86224730	73939	1	SPRING, COMP, 12MM OD X 12.7MM		
4	86215410	140416	3	BOOT, CIRCUIT BREAKER MP/MB		
5	86007130	72128	1	SWITCH, DPDT 2-POSITION ROCKER		
6	86225960	89503	1	WELDMENT, ELECTRICAL PANEL		
7	86005700	57104	2	NUT, 10-32 W/STAR		
8	86221820	51467	1	LIGHT, INDICATOR, RED, 120VAC		
9	86218960	41575	1	HOOK, UPPER, CORD		
10	86223830	70927	1	SCR, M8X40, SHCS, ISO 4762, SST		
11A	86217150	23733	1	CORD ASM, 14/3 SJT X 75' YLW		
11B	86217160	23734	1	CORD ASM, EURO 1.5 MM X 75 BLK		
11C	86217170	23735	1	CORD ASM, AUST 1.5MM X 75 BLK		
12A	86215670	140839	3	BREAKER, 8A VDE CIRCUIT		120V ONLY
12B	86215710	141046	3	BREAKER, 5A VDE CIRCUIT		230V ONLY
13	86218290	35382	4	GASKET, CONSOLE, HANDLE		
14	86276820	70740	3	SCR, 10-32 X 1/2 PTHMS BLK NP		
15	86299320	-	1	LABEL, GROUND SYMBOL		230V ONLY
16	86010640	87016	1	WASHER, #10 LOCK EXT STAR SS		

COVER

REF	PART NO.	PRV NO.	QTY	DESCRIPTION	SERIAL NO. FROM	NOTES:
1	86217470	270800	1	COVER, ACCESSORY PORT		
2	86218300	36250	1	GASKET, ACCESSORY PORT COVER		
3	86173330	87513	5	WASHER, M5, FLAT, ISO7093, SS		
4	86293360	-	1	SCR, M5X12 GR 8.8, PLT		
5	86293390	-	2	SCR, M5X15 SHCS, GR 10.9 BLK		
6	86173350	87515	2	WASHER, M5, FLAT, ISO7089, SS		
7	86008650	80604	6	COTTER, 1/4" RING		
8	86222620	66891	1	PIN, 5MM DIA X 85MM L		
9	86216030	620119	1	BRKT, ACCESSORY PORT HINGE		
10	86225080	72152	1	SWITCH, 125 VAC SP NC ROLLER		
11	86173110	70936	2	SCR, M3X16, BSHCS, ISO7380, SST		
12	86225630	75478	1	VACUUM LID, TRIM		
13	86218200	35372	1	GASKET, FITTING ACCESSORY PORT		
14	86217880	34458	1	FITTING, ACCESSORY PORT		
15	OPEN	-	-	-		
16	86295530	-	1	NUT, HEX, M3, PLT		
17	86274340	70179	6	SCR, M6 X 16 PH		
18	86215160	141059	1	BASKET, FILTER BAG MOLDED		
19	86238080	36261	2	GASKET, 1 W X 5/8 FOAM, M		
20	86238070	36260	2	GASKET, 1 W X 5/8 FOAM, F		
21	86222640	66893	2	PIN, 6 MM DIA X 60 MM LG		
22	86223780	70896	2	SCR, M4X8, SET, ISO4029, CP, BLK		
23	86293420	-	4	SCR, M8X20 FHCS BR 10.9 BLK		
24	86218930	41569	2	HINGE, LID		
25	86222640	66893	2	PIN, 6 MM DIA X 60 MM LG		
26	OPEN	-	-	-		
27	86224770	739989	1	SPRING, TORSION		
28	86222960	62866	1	PLATE, ACCESSORY PORT		
29	86014530	-	4	SCR, KA50X16, PT, WN1412,PL		
30	86216750	20098	1	CLAMP, WORM GEAR 40-64MM		
31	86219120	39736	1	HOSE, 2.0 ID X 15.75L, 3.5:1		
32	86311920	-	1	SNAP RING, 50MM ID, BLACK		
-	86215090	140949	-	BAG, PAPER WIDE AREA VAC		NOT SHOWN

DECAL

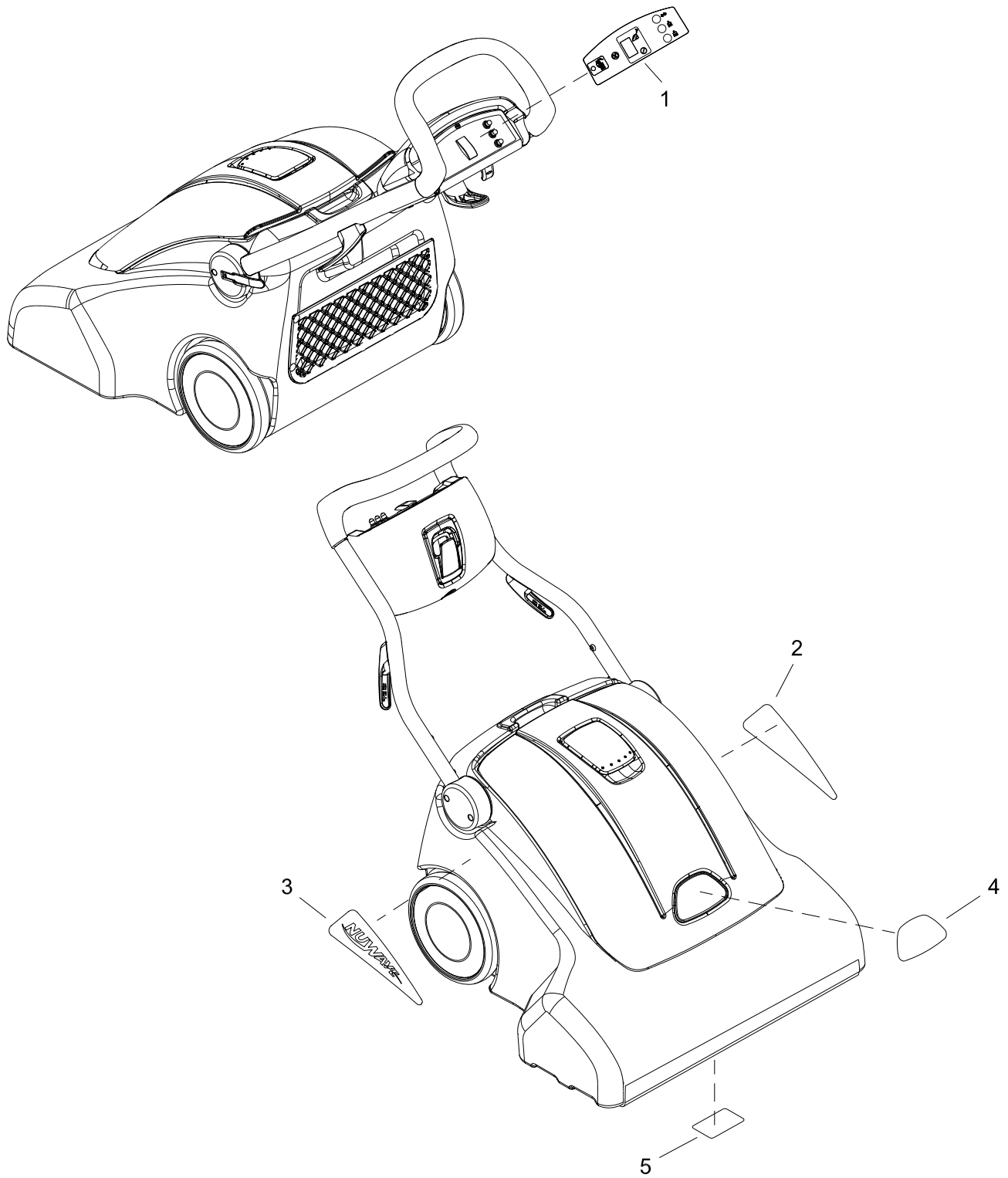

DECAL

REF	PART NO.	PRV NO.	QTY	DESCRIPTION	SERIAL NO. FROM	NOTES:
1	86221460	501207	1	LABEL, CONTROL PANEL VACUUM		
2	86221530	501243	1	LABEL, NUWAVE RT		
3	86221540	501244	1	LABEL, NUWAVE LT		
4	86004970	50990	1	LABEL, WINDSOR LOGO DOMED		
5	86012590	-	1	LABEL, BRUSH INSTALLATION		

FRAME

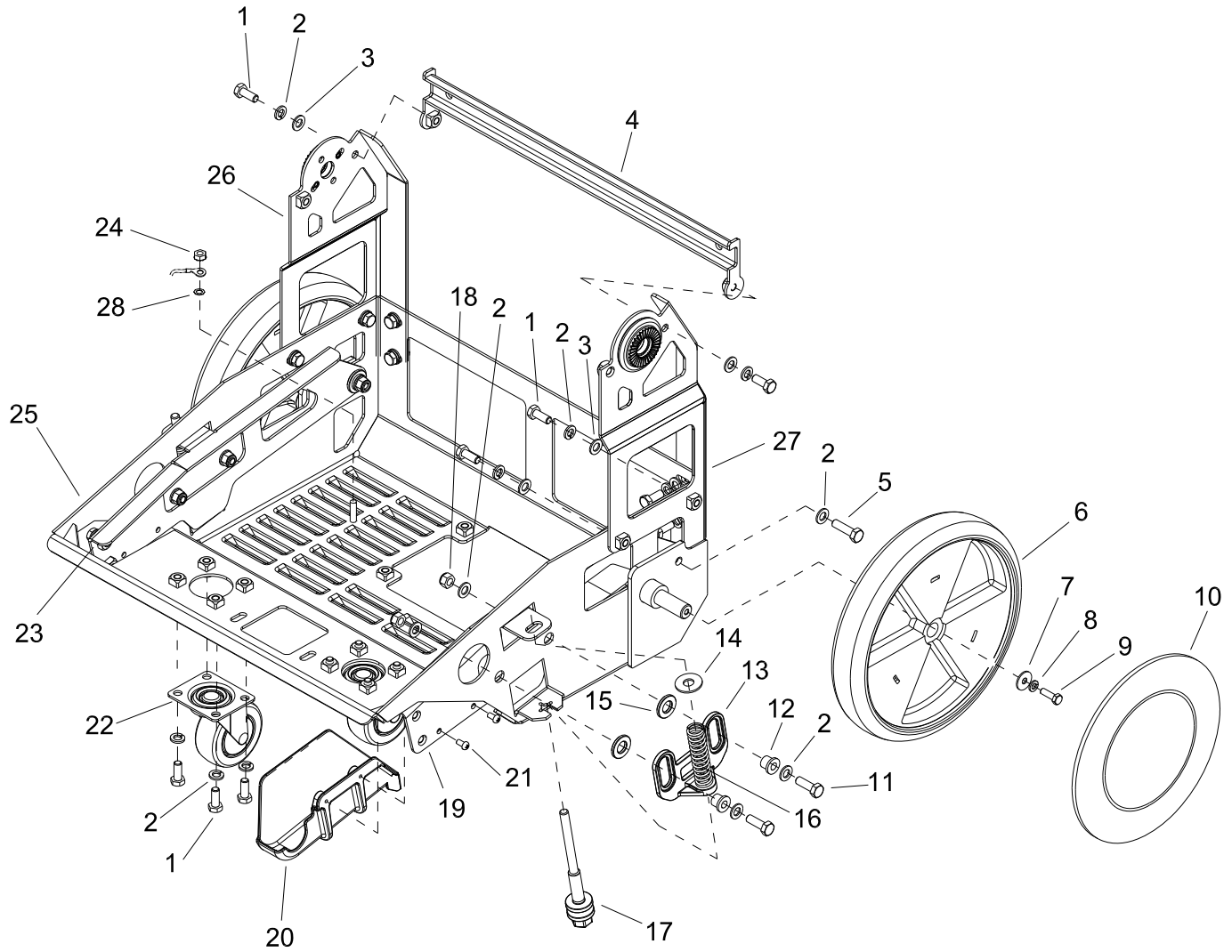

FRAME

REF	PART NO.	PRV NO.	QTY	DESCRIPTION	SERIAL NO. FROM	NOTES:
1	86274860	70311	18	SCR. M8X20 HHMS		
2	86137310	87098	18	WASHER, M8 SPLIT LOCK		
3	86137280	87054	20	WASHER, M8 FLAT DIN125A PLT		
4	86295660	-	1	WELDMENT, HANDLE BRACE		
5	86295780	-	2	M8X40 HHCS GR 8.8 PLT		
6	86226050	89279	2	WHEEL, 9.75" X 1.5"		
7	86225730	87218	2	WASHER, M6 (20.5 ODX1.6T) PLT		
8	86173310	87499	2	WASHER, SPRING LK, M6, DIN127B, SST		
9	86293430	-	2	SCR, M6 X 16 HHMS GR 10.9 PLT		
10	86219480	41567	2	HUBCAP, 9.75 WHEEL		
11	86293440	-	4	SCR, M8X25 HHCS BR 8.8 PLT		
12	86228840	09124	6	BEARING, FLANGED .314IDX.502OD		
13	86215890	140951	2	BRKT, SPRING ADJUST		
14	86010720	87086	2	WASHER, M10 X 30 PLTD		
15	86259400	87205	8	WASHER, THRUST .51 ID X 1 ODBRO		
16	86224690	730438	2	SPRING, .718OD X 3.41L X .091W		
17	86223810	70925	2	SCR, ADJUSTMENT DECK SPRING		
18	86196610	94045	6	NUT, M8 HEX NYLOCK		
19	86216020	34461	1	BRKT, DECK LINGAGE, LEFT		
20	86218430	36253	1	GUARD, BELT BRUSH DRIVE		
21	86172980	70912	2	SCR, KA50X10, PT OHS, WN1412, PLTD		
22	86002340	18045	2	CASTER, 3.0 SWIVEL		
23	86216010	34460	1	BRKT, DECK LINKAGE, RIGHT		
24	86005700	57104	1	NUT, 10-32 W/STAR		
25	86217980	89499	1	FRAME, WELDMENT		
26	86225970	89508	1	WELDMENT, HANDLE BRKT, RIGHT		
27	86225980	89509	1	WELDMENT, HANDLE BRKT, LEFT		
28	86010640	87016	1	WASHER, #10 EXT STAR LOCK SS		

HANDLE

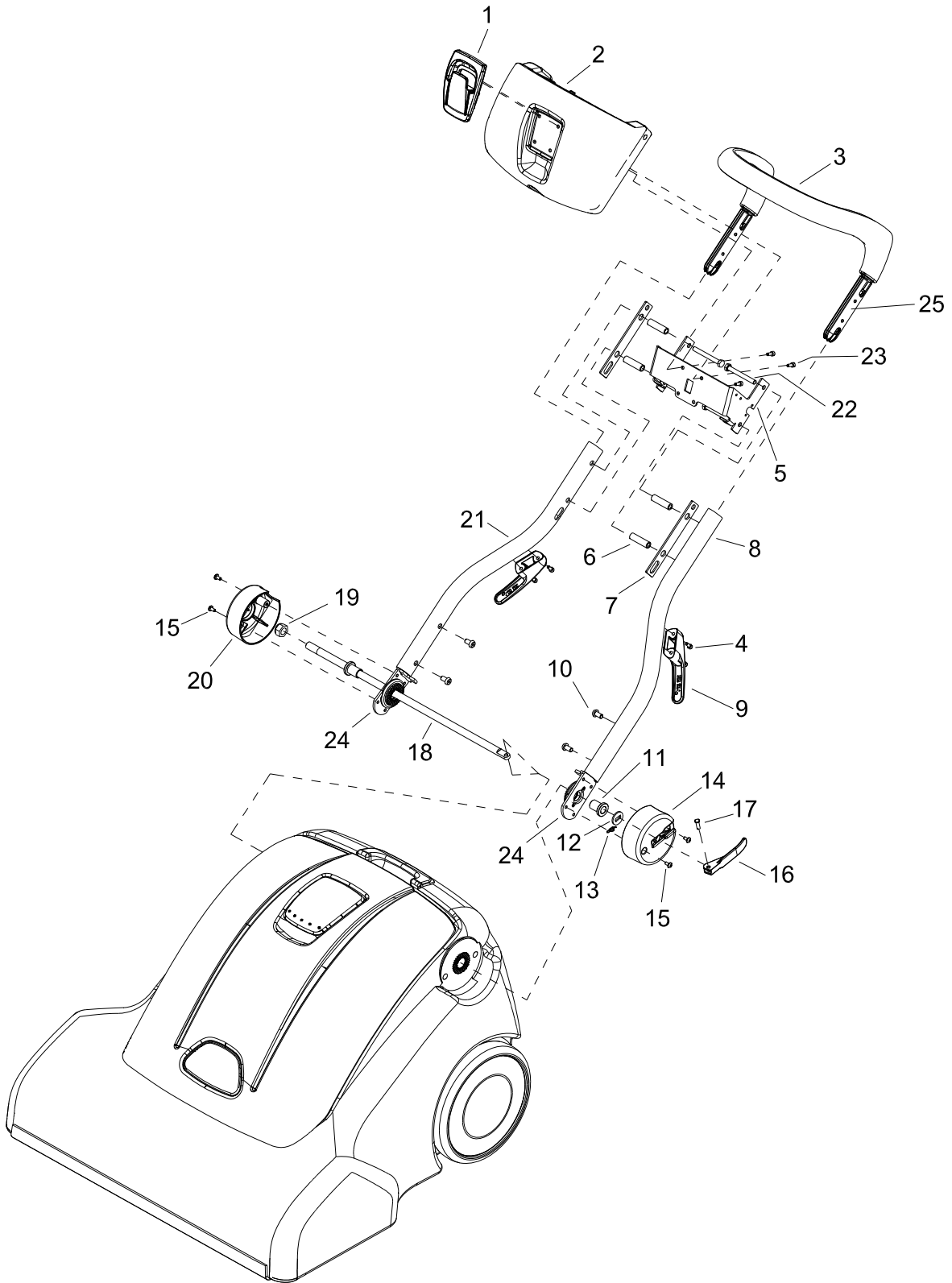

REF	PART NO.	PRV NO.	QTY	DESCRIPTION	SERIAL NO. FROM	NOTES:
1	86218970	41593	1	HOOK, CORD, CONSOLE		
2	86298140	-	1	CONSOLE, TRIMMED, BLU		
3	86218600	38346	1	HANDLE, MAIN, MOLDED GRIP		
4	86293400	-	4	SCR, M5X12 SHCS GR 10.9 PLT		
5	86215630	14878	1	BRACKET, LEVER, CONSOLE		
6	86224540	73588	4	SPACER, 8.5 ID X 45L		
7	86218190	35371	2	GASKET, CONSOLE, TUBE		
8	86218720	38369	1	HANDLE, EXTRUSION, LEFT		
9	86218950	41574	2	HOOK, LOWER, CORD		
10	86293410	-	4	SCR, M8X15 BHCS GR 8.8 PLT		
11	86216460	149983	2	BUSHING, AXLE, LEVER		
12	86225860	87519	1	WASHER, LEVER, CAM HANDLE		
13	86008650	80604	1	COTTER, 1/4" RING		
14	86216580	270159	1	CAP, END, HANDLE, LEFT		
15	86173020	70916	4	SCR, M5 X 10, PPHMS, ISO7045, SS		
16	86221770	51470	1	LEVER, CAM HANDLE		
17	86292910	-	1	PIN, COTTER, LEVER, 6MM		
18	86224180	730433	1	AXLE, PIVOT, HANDLE		
19	86294660	-	1	NUT, M14 X 2.0 LOCK, ISO7040, DIN985		
20	86216560	270158	1	CAP, END, HANDLE, RIGHT		
21	8621570	38368	1	HANDLE, EXTRUSION, RIGHT		
22	86293370	-	4	SCR, M8 X 70, HHCS, GR 10.9 PLT		
23	86293390	-	4	SCR, M5 X 15 SHCS GR 10.9 BLK		
24	86225990	89510	2	WLDMNT, MNTG PLATE, HANDLE		
25	86224500	730417	4	SPACER, HANDLE EXTRUSION		

HOUSING

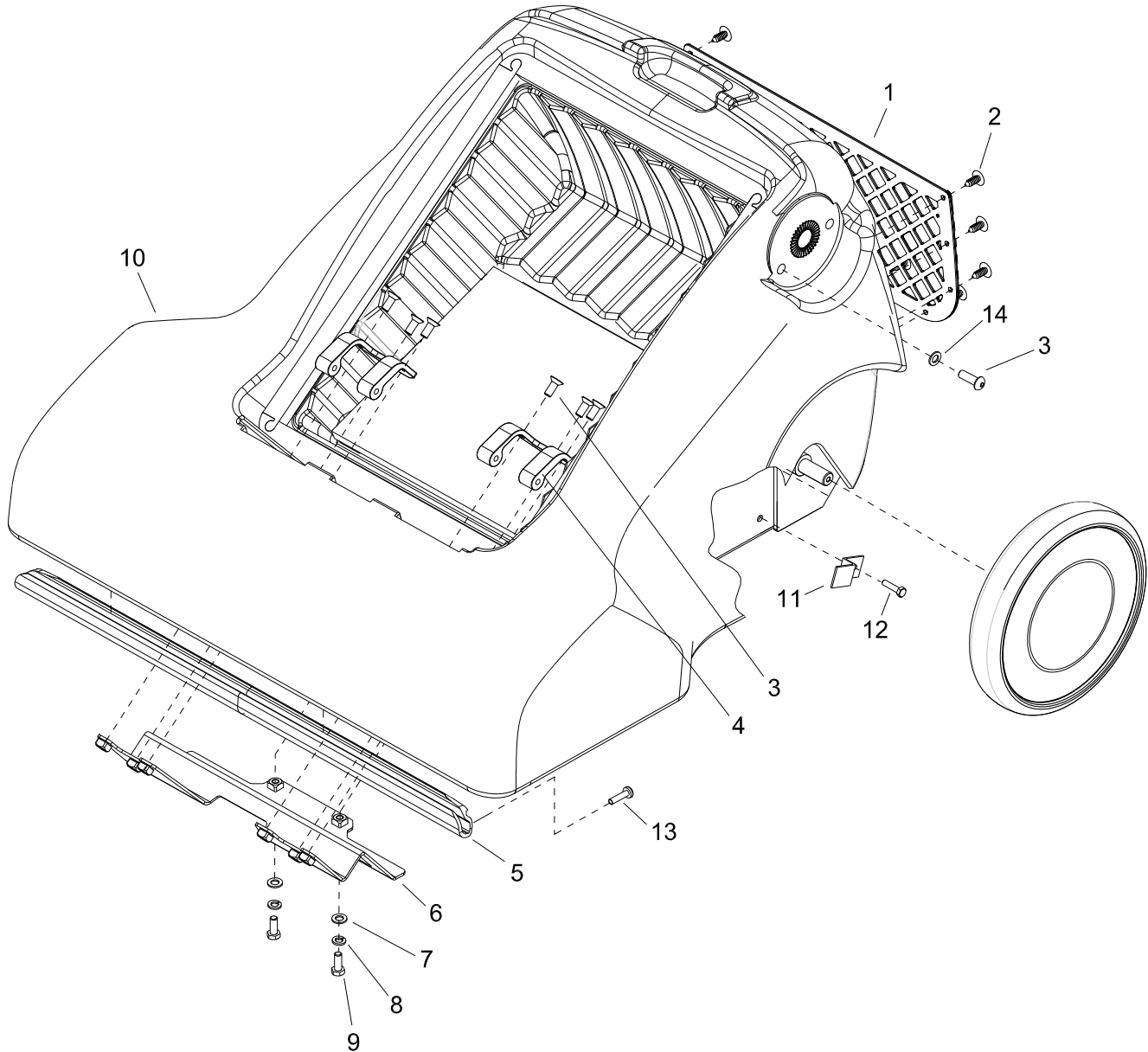

HOUSING

REF	PART NO.	PRV NO.	QTY	DESCRIPTION	SERIAL NO. FROM	NOTES:
1	86222230	58010	1	NET, CARGO, MOLDED		
2	86292430	-	11	CLIP, TREE, FASTENER		
3	86297590	-	6	SCR, M8X25 FHCS, BLK		
4	86218940	41570	2	HINGE, BODY		
5	86291240	-	1	RAIL, GLIDE, EXTRUDED		
6	86215900	140952	1	BRKT, BODY/HINGE MOUNT		
7	86137280	87054	4	WASHER, M8 FLAT DIN125A PLT		
8	86137310	87098	2	WASHER, M8 SPLIT LOCK		
9	86274860	70311	2	SCR, M8X20 HHMS		
10	86225610	75477	1	VACUUM BODY, TRIM		
11	86295940	-	2	BRACKET, CLIP, ROTOMOLD		
12	86223680	70700	2	SCR, M5X.8X10 PHMS BLK		
13	86014530	-	2	SCR, KA50X16, PT, WN1412, PL		
14	86303870	-	2	SCR, M8 X 20, BHCS, BLK		

VACUUM

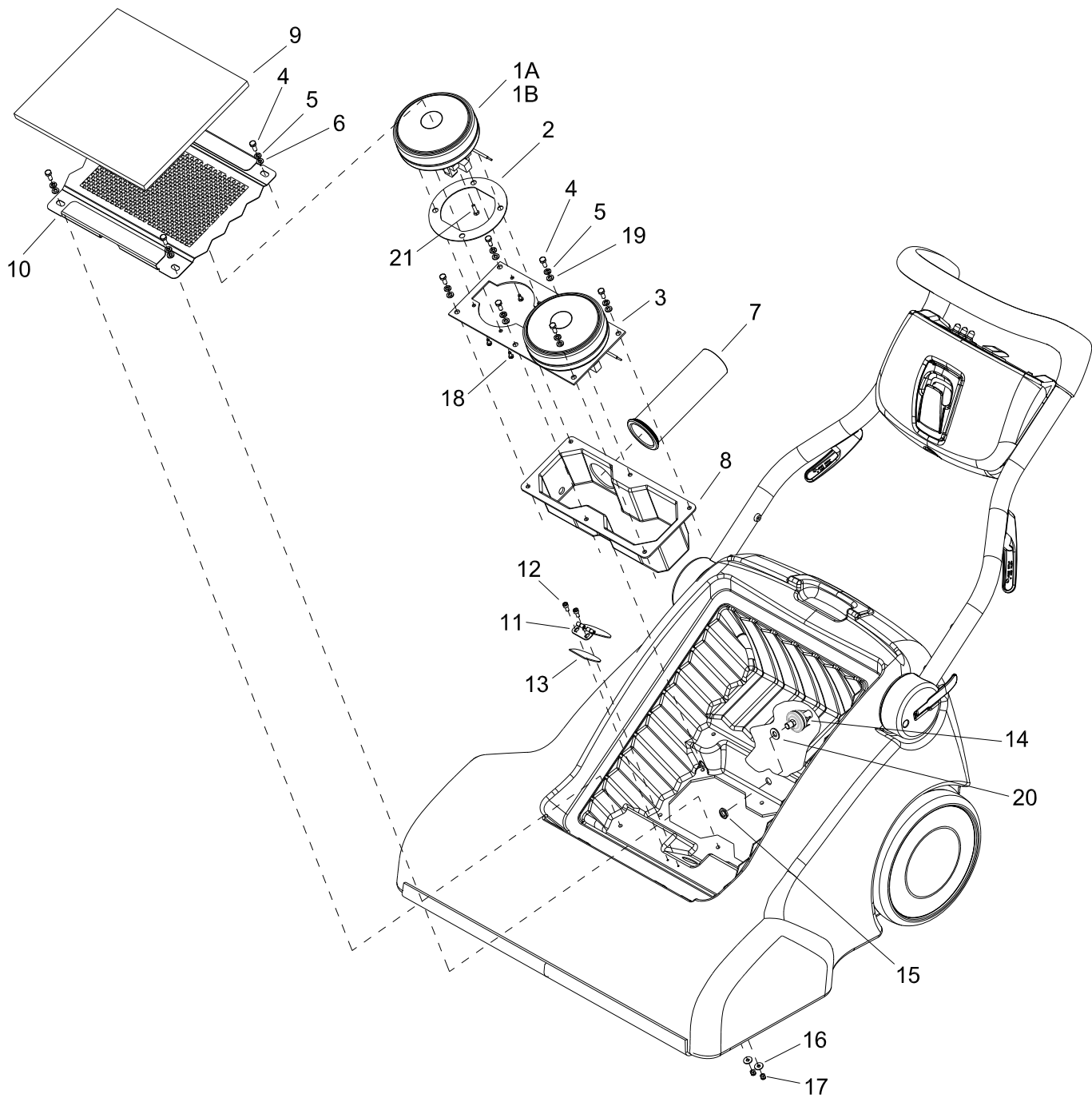

VACUUM

REF	PART NO.	PRV NO.	QTY	DESCRIPTION	SERIAL NO. FROM	NOTES:
1A	86225510	53817	2	VAC MOTOR, 120V 5.7 1ST TF		120V ONLY
1B	86225520	53819	2	VAC MOTOR, 230V 5.7 1ST TF		230V ONLY
2	86218310	36251	2	GASKET, 5.50OD X 3.85ID X .06		
3	86223070	62978	1	PLATE, MOUNT, VAC MOTOR		
4	86293430	-	10	SCR, M6X16 HHMS GR 10.9 PLT		
5	86173310	87499	10	WASHER, SPRING LK, M6, DIN127B, SST		
6	86279070	87056	4	WASHER, M6 FLAT		
7	86290450	-	1	TUBE, EXHAUST, VAC CHAMBER		
8	86290120	-	1	BOX, ENCLOSURE, VAC MOTOR		
9	86217850	34459	1	FILTER, VAC CHAMBER		
10	86223960	739988	1	SCREEN, VAC CHAMBER		
11	86234760	27674	1	COVER, ACCESSORY PORT		
12	86293390	-	2	SCR, M5X15 SHCS GR10.9 BLK		
13	86003780	35171	1	GASKET, ACCESSORY PORT		
14	86257160	72199	1	SWITCH, VACUUM 15" H2O NC/NO		
15	86137350	87216	1	WASHER, 1/8NPT, BRASS		
16	86173330	87513	2	WASHER, M5, FLAT, ISO7093, SS		
17	86024750	94028	2	NUT, M5 HEX NYLOCK		
18	86277380	70835	8	SCR, M4.8 X 16 PHTF		
19	86225730	87218	6	WASHER, M6 (20.5 OD X 1.6 T) PLT		
20	86010720	87086	1	WASHER, M10 X 30 PLTD		
21	86288450	70689	2	SCR, M4.8 X 10 HHTF TYPE B		

WIRING DIAGRAM-120V

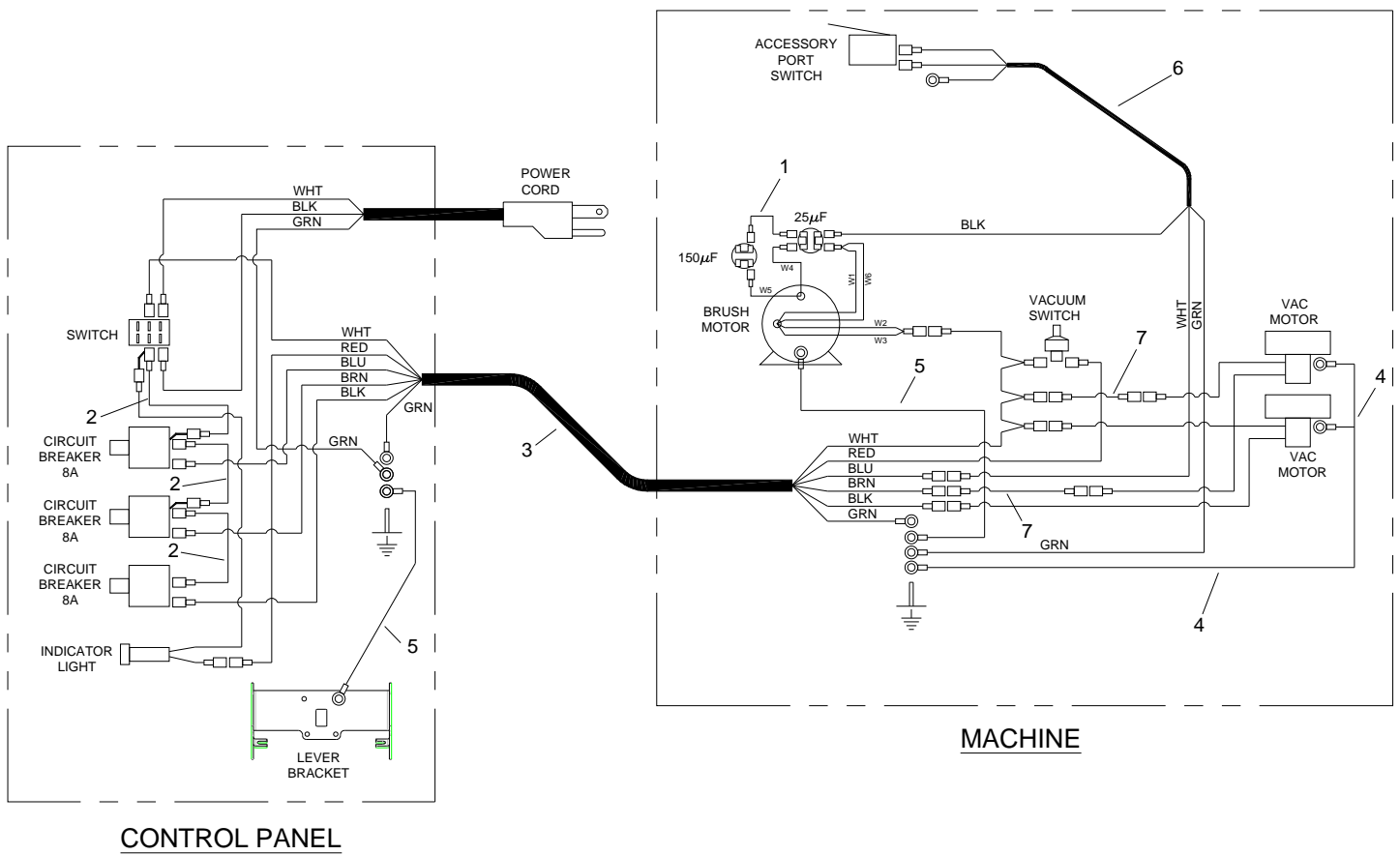

WIRING DIAGRAM-120V

REF	PART NO.	PRV NO.	QTY	DESCRIPTION	SERIAL NO. FROM	NOTES:
1	86266900	880095	1	WIRE, 5" BLK/14 76029 X 76029		
2	86268400	88301	3	WIRE, 3" BLK/14 76029 X 76050		
3	86218860	41579	1	HARNESS, MAIN VACUUM		
4	86267290	880262	2	WIRE, 14" GRN/18 76008 X 76011		
5	86268210	88205	2	WIRE, 15" GRN/18 76008 X 76008		
6	86218850	41578	1	HARNESS, SWITCH VACUUM		
7	86295540	-	2	WIRE, JUMPER, 130L X 14GA BLK		

WIRING DIAGRAM-230V

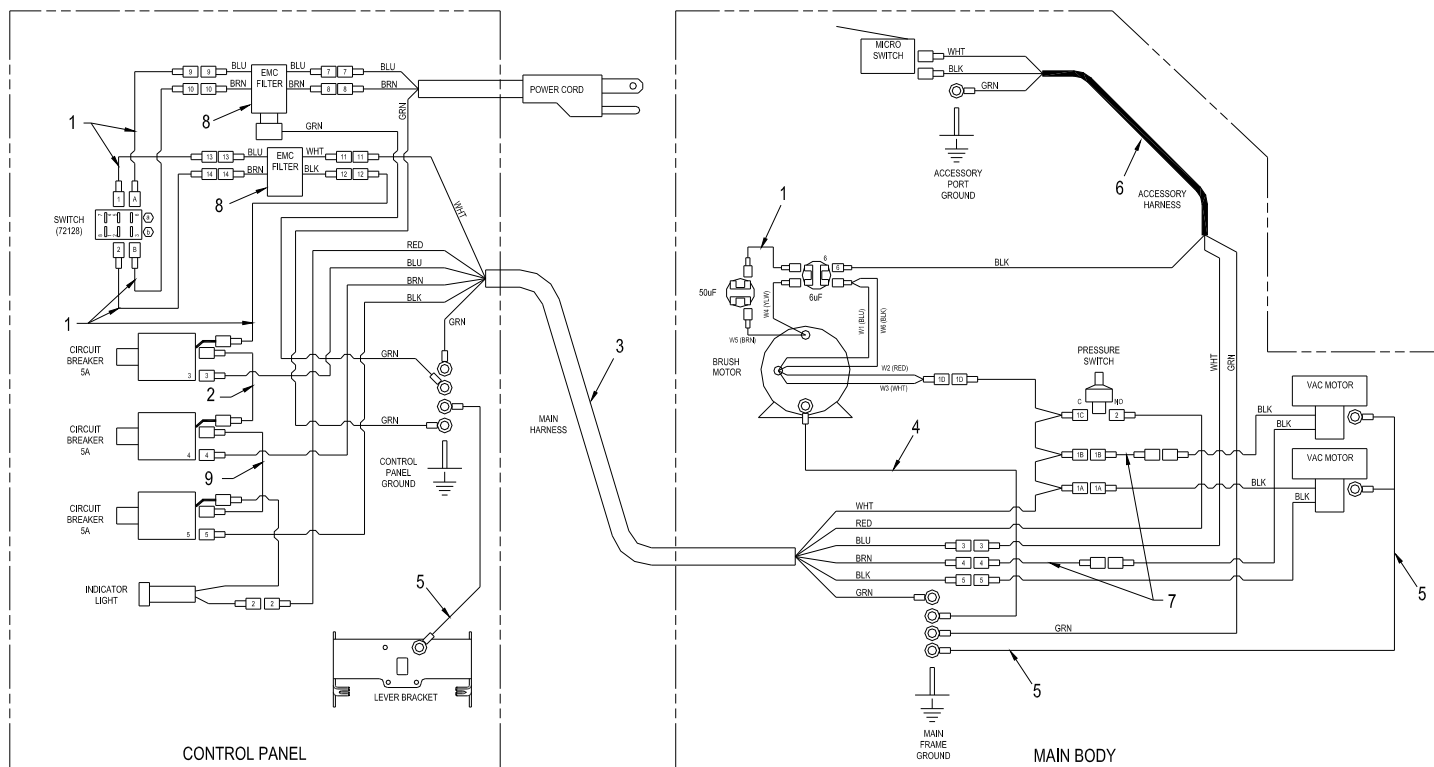

WIRING DIAGRAM-230V

REF	PART NO.	PRV NO.	QTY	DESCRIPTION	SERIAL NO. FROM	NOTES:
1	86266900	880095	6	WIRE, 5" BLK/14 76029 X 76029		
2	86268400	88301	2	WIRE, 3" BLK/14 76029 X 76050		
3	86218860	41579	1	HARNESS, MAIN, VACUUM		
4	86267290	880262	1	WIRE, 14" GRN.18 76008 X 76011		
5	86268210	88205	3	WIRE, 15" GRN/18 76008 X 76008		
6	86218850	41578	1	HARNESS, SWITCH VACUUM		
7	86295540	-	2	WIRE, JUMPER, 130L X 14GA BLK		
8	86217770	23213	1	EMC TILTER ASSY		
9	86303880	-	1	WIRE, 3" BLK/14 76050X76050		

SUGGESTED SPARE PARTS

REF	PART NO.	PRV NO.	DESCRIPTION	SERIAL NO. FROM	NOTES:
1	86216120	12543	BRUSH, 25.5 X 4.0 OD, FRONT		
2	86216110	12540	BRUSH, 25.5 X 4.0 OD, REAR		
3	86215310	11056	BELT, TIMING, 5MM X 15MM X 575		
4	86291380	-	BELT, 290J6, MICRO-V		
5A	86215670	140839	BREAKER, 8A VDE CIRCUIT		120V ONLY
5B	86215710	141046	BREAKER, 5A VDE CIRCUIT		230V ONLY
6	86007130	72128	SWITCH, DPDT 2-POSITION ROCKER		
7	86135320	140687	BRUSH SET		120V & 230V
8	86215090	140949	BAG, PAPER WIDE AREA VAC		
9	86224630	730380	SPRING, BRUSH CLIP		
10	86012790	-	SHAFT ASM, BRUSH DRIVE		
11	86217850	34459	FILTER, VAC CHAMBER		
12	86292930	-	GASKET, BASE PLATE		
13	86218290	35382	GASKET, CONSOLE, HANDLE		
14	86238080	36261	GASKET, 1 W X 5/8 FOAM, M		
15	86238070	36260	GASKET, 1 W X 5/8 FOAM, F		
16	86218200	35372	GASKET, FITTING ACCESSORY PORT		
17	86218190	35371	GASKET, CONSOLE, TUBE		
18	86003780	35171	GASKET, ACCESSORY PORT		
19	86218310	36251	GASKET, 5.50OD X 3.85ID X .06		

OPTIONS

86011370 NUWAVE 08/11/08

HOLSTER-OPTION

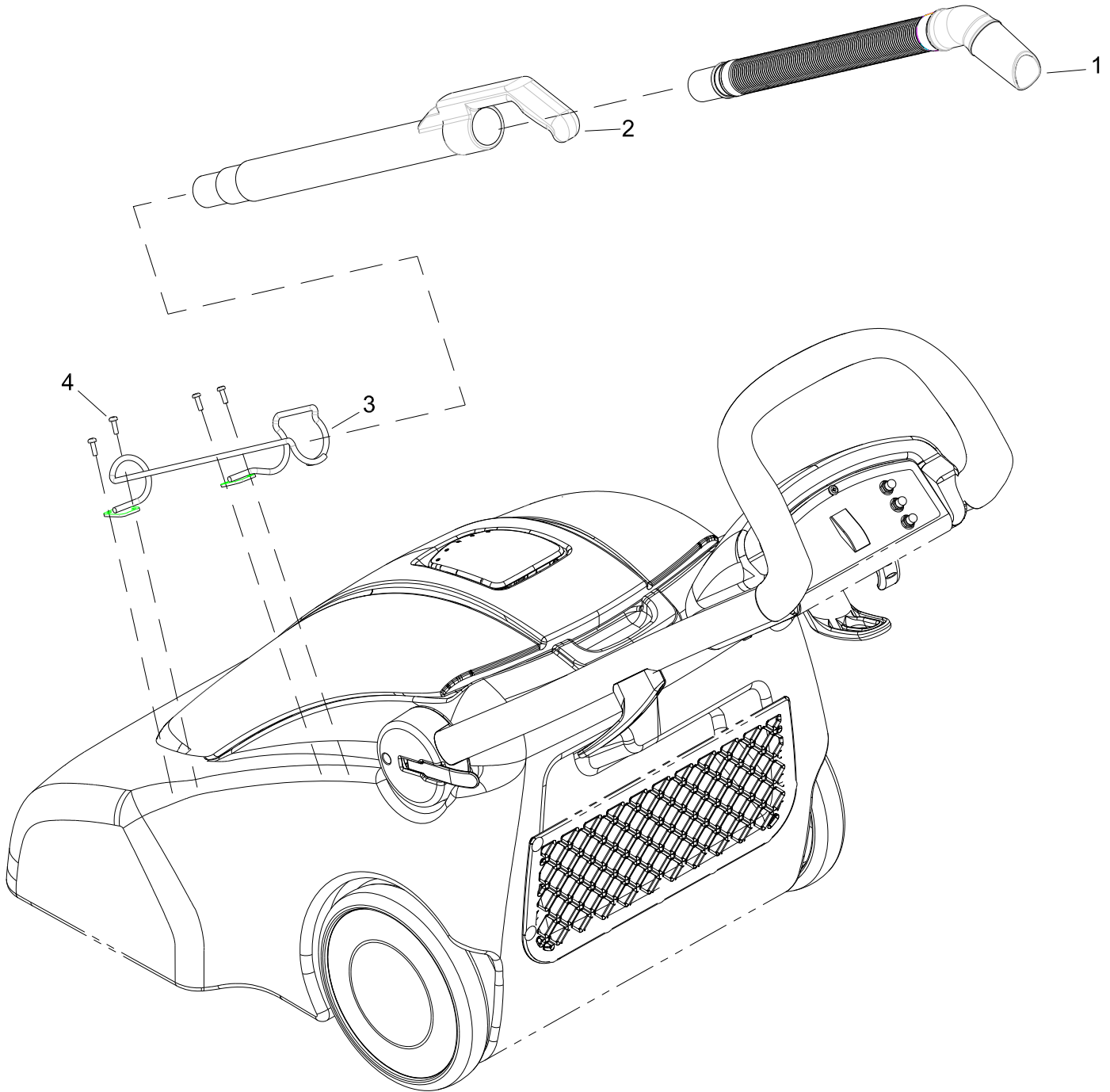

HOLSTER - OPTION

REF	PART NO.	PRV NO.	QTY	DESCRIPTION	SERIAL NO. FROM	NOTES:
1	86308710	-	1	ASSY, HOSE		
2	86141550	5045HG	1	EXTENSION TUBE		
3	86305100	-	1	WIRE FORM, HOLSTER		
4	86276850	70745	4	SCR, #10 X 5/8 PPHST HI LO BLK		

NOTES:

Free Manuals Download Website

<http://myh66.com>

<http://usermanuals.us>

<http://www.somanuals.com>

<http://www.4manuals.cc>

<http://www.manual-lib.com>

<http://www.404manual.com>

<http://www.luxmanual.com>

<http://aubethermostatmanual.com>

Golf course search by state

<http://golfingnear.com>

Email search by domain

<http://emailbydomain.com>

Auto manuals search

<http://auto.somanuals.com>

TV manuals search

<http://tv.somanuals.com>