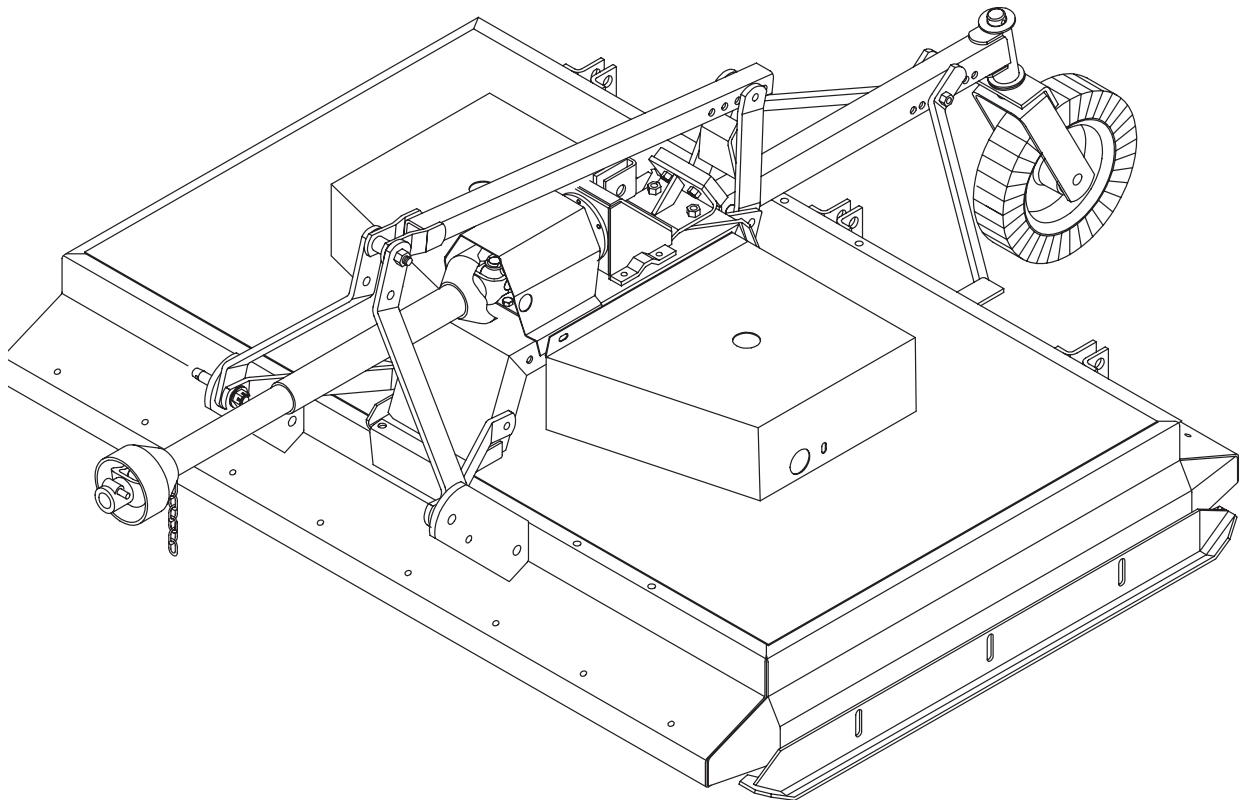


# WOODS ROTARY CUTTER

D80-2  
MD80-2



15914

Rev. 5/11/2007

**WOODS**<sup>®</sup>  
Tested. Proven. Unbeatable.

OPERATOR'S MANUAL

## TO THE DEALER:

Assembly and proper installation of this product is the responsibility of the Woods® dealer. Read manual instructions and safety rules. Make sure all items on the Dealer's Pre-Delivery and Delivery Check Lists in the Operator's Manual are completed before releasing equipment to the owner.

The dealer must complete the Product Registration included with the Operator's Manual. The customer must sign the registration which certifies that all Dealer Check List items have been completed. The dealer is to return the prepaid postage portion to Woods, give one copy to the customer, and retain one copy. **Failure to complete and return this card does not diminish customer's warranty rights.**

## TO THE OWNER:

Read this manual before operating your Woods equipment. The information presented will prepare you to do a better and safer job. Keep this manual handy for ready reference. Require all operators to read this manual carefully and become acquainted with all adjustment and operating procedures before attempting to operate. Replacement manuals can be obtained from your dealer. To locate your nearest dealer, check the Dealer Locator at [www.WoodsEquipment.com](http://www.WoodsEquipment.com), or in the United States and Canada call 1-800-319-6637.

The equipment you have purchased has been carefully engineered and manufactured to provide dependable and satisfactory use. Like all mechanical products, it will require cleaning and upkeep. Lubricate the unit as specified. Observe all safety information in this manual and safety decals on the equipment.

For service, your authorized Woods dealer has trained mechanics, genuine Woods service parts, and the necessary tools and equipment to handle all your needs.

Use only genuine Woods service parts. Substitute parts will void the warranty and may not meet standards required for safe and satisfactory operation. Record the model number and serial number of your equipment in the spaces provided:

**Model:** \_\_\_\_\_ **Date of Purchase:** \_\_\_\_\_

**Serial Number: (see Safety Decal section for location)** \_\_\_\_\_

Provide this information to your dealer to obtain correct repair parts.

Throughout this manual, the term **IMPORTANT** is used to indicate that failure to observe can cause damage to equipment. The terms **CAUTION**, **WARNING**, and **DANGER** are used in conjunction with the Safety-Alert Symbol (a triangle with an exclamation mark) to indicate the degree of hazard for items of personal safety.



This Safety-Alert Symbol indicates a hazard and means **ATTENTION! BECOME ALERT! YOUR SAFETY IS INVOLVED!**



Indicates an imminently hazardous situation that, if not avoided, will result in death or serious injury.



Indicates a potentially hazardous situation that, if not avoided, could result in death or serious injury, and includes hazards that are exposed when guards are removed.



Indicates a potentially hazardous situation that, if not avoided, may result in minor or moderate injury.

**IMPORTANT  
or NOTICE**

Indicates that failure to observe can cause damage to equipment.

**NOTE**

Indicates helpful information.

**WOODS®**

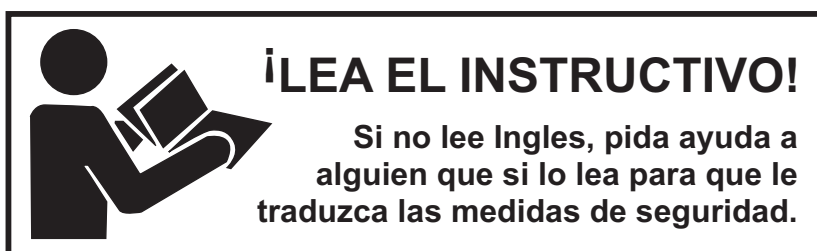
**ALITEC™**  
**BMP®**  
**CENTRAL FABRICATORS®**  
**GANNON®**  
**GILL®**  
**WAIN-ROY®**  
**WOODS®**

## 2 Introduction

Gen'l (Rev. 2/5/2007)

# TABLE OF CONTENTS

INTRODUCTION .....	2
SPECIFICATIONS .....	4
GENERAL INFORMATION .....	4
SAFETY VIDEO ORDER FORM .....	5
SAFETY RULES .....	7
SAFETY DECALS .....	10
OPERATION .....	13
OWNER SERVICE .....	18
DEALER SERVICE .....	22
TROUBLESHOOTING .....	27
ASSEMBLY .....	28
DEALER CHECK LISTS .....	36
INDEX TO PARTS LIST .....	37
BOLT TORQUE CHART .....	57
BOLT SIZE CHART .....	58
INDEX .....	59
REPLACEMENT PARTS WARRANTY .....	60
PRODUCT WARRANTY .....	INSIDE BACK COVER



**This Operator's Manual should be regarded as part of the machine. Suppliers of both new and second-hand machines must make sure that this manual is provided with the machine.**

# SPECIFICATIONS

	<u>D80-2 (Towed)</u>	<u>MD80-2 (Mounted)</u>
Cutting Width	80"	80"
Cutting Height	2" - 14"	2" (Limited by tractor lift)
Overall Width	83"	83"
Cutter Blade Spindles	2	2
Blade Tip Speed	14,400	14,400
V-Belts	3	3
Framework Channel	5/16"	5/16"
Spindle Shafts	1-3/8"	1-3/8"
Gearbox	60 HP	60 HP

## TRACTOR REQUIREMENTS

	<u>D80-2 (Towed)</u>	<u>MD80-2 (Mounted)</u>
Tractor PTO	540 rpm	540 rpm
3-Point Hitch	N/A	Category 1 (Category 2 Optional)

## GENERAL INFORMATION

The purpose of this manual is to assist you in operating and maintaining your cutter. Read it carefully. It furnishes information and instructions that will help you achieve years of dependable performance. These instructions have been compiled from extensive field experience and engineering data. Some information may be general in nature due to unknown and varying operating conditions. However, through experience and these instructions, you should be able to develop procedures suitable to your particular situation.

The illustrations and data used in this manual were current at the time of printing, but due to possible inline production changes, your machine may vary slightly in

detail. We reserve the right to redesign and change the machines as may be necessary without notification.

### **WARNING**

■ **Some illustrations in this manual show the equipment with safety shields removed to provide a better view. The equipment should never be operated with any safety shielding removed.**

**BE SAFE!**

**BE ALERT!**

**BE ALIVE!**

**BE TRAINED  
BEFORE OPERATING**



ASSOCIATION OF  
EQUIPMENT  
MANUFACTURERS

*Safety Training  
Does Make a Difference.*

---

## Free Mower Safety Video

Fill out and return the order form and we will send you a FREE VHS or DVD video outlining ***Industrial and Agricultural Mower Safety Practices***. The 22 minute video, developed in cooperation with AEM (Association of Equipment Manufacturers), reinforces the proper procedures to follow while operating your Woods mowing equipment. The video does not replace the information contained in the Operator's Manual, so please review this manual thoroughly before operating your new mowing equipment.

**Also, available from the Association of Equipment Manufacturers:**

A large variety of training materials (ideal for groups) are available for a nominal charge from AEM. Following is a partial list:

- **Training Package for Rotary Mowers/Cutters--English**  
Contains: DVD & VHS (English)  
    Guidebook for Rotary Mowers/Cutters (English)  
    AEM Industrial/Agricultural Mower Safety Manual (English)  
    AEM Agricultural Tractor Safety Manual (English)
  
- **Training Package for Rotary Mowers/Cutters-English/Spanish**  
Contains: DVD & VHS (English/Spanish)  
    Guidebook for Rotary Mowers/Cutters (English/Spanish)  
    AEM Indust./Agricultural Mower Safety Manual (English/Spanish)  
    AEM Agricultural Tractor Safety Manual (English/Spanish)

AEM training packages are available through:

AEM at: *www.aem.org*  
or  
Hubbard Publishing  
800-369-2310 tel  
608-846-3398 fax



---

## Free Mower/Cutter Safety Video Order Form

Please send me  (Select one)  
 **VHS** Format - VHS01052 Safety Video  
 **DVD** Format - DVD01052 Safety Video

Name: \_\_\_\_\_ Phone: \_\_\_\_\_

Address: \_\_\_\_\_  
\_\_\_\_\_  
\_\_\_\_\_

Mower/Cutter Model: \_\_\_\_\_ Serial #: \_\_\_\_\_

Send to: ATTENTION: DEALER SERVICES  
**WOODS EQUIPMENT COMPANY**  
PO BOX 1000  
OREGON IL 61061-1000

# SAFETY RULES



**ATTENTION! BECOME ALERT! YOUR SAFETY IS INVOLVED!**



Safety is a primary concern in the design and manufacture of our products. Unfortunately, our efforts to provide safe equipment can be wiped out by an operator's single careless act.

In addition to the design and configuration of equipment, hazard control and accident prevention are dependent upon the awareness, concern, judgement, and proper training of personnel involved in the operation, transport, maintenance and storage of equipment.

It has been said "The best safety device is an informed, careful operator." We ask you to be that kind of operator.

## TRAINING

- **Safety instructions are important! Read all attachment and power unit manuals; follow all safety rules and safety decal information. (Replacement manuals and safety decals are available from your dealer. To locate your nearest dealer, check the Dealer Locator at [www.WoodsEquipment.com](http://www.WoodsEquipment.com), or in the United States and Canada call 1-800-319-6637.) Failure to follow instructions or safety rules can result in serious injury or death.**
- **If you do not understand any part of this manual and need assistance, see your dealer.**
- **Know your controls and how to stop engine and attachment quickly in an emergency.**
- **Operators must be instructed in and be capable of the safe operation of the equipment, its attachments, and all controls. Do not allow anyone to operate this equipment without proper instructions.**
- **Keep hands and body away from pressurized lines. Use paper or cardboard, not hands or other body parts to check for leaks. Wear safety goggles. Hydraulic fluid under pressure can easily penetrate skin and will cause serious injury or death.**
- **Make sure that all operating and service personnel know that if hydraulic fluid penetrates skin, it must be surgically removed as soon as possible by a doctor familiar with this form of injury or gangrene, serious injury, or death will result. CONTACT A PHYSICIAN IMMEDIATELY IF FLUID ENTERS SKIN OR EYES. DO NOT DELAY.**

- **Never allow children or untrained persons to operate equipment.**

## PREPARATION

- **Check that all hardware is properly installed. Always tighten to torque chart specifications unless instructed otherwise in this manual.**
- **Always wear relatively tight and belted clothing to avoid entanglement in moving parts. Wear sturdy, rough-soled work shoes and protective equipment for eyes, hair, hands, hearing, and head; and respirator or filter mask where appropriate.**
- **Make sure attachment is properly secured, adjusted, and in good operating condition.**
- **Make sure spring-activated locking pin or collar slides freely and is seated firmly in tractor PTO spline groove.**
- **Make sure driveline shield tether chains are attached to the tractor and equipment as shown in this manual. Replace if damaged or broken. Check that driveline guards rotate freely on driveline before putting equipment into service.**
- **Power unit must be equipped with ROPS or ROPS cab and seat belt. Keep seat belt securely fastened. Falling off power unit can result in death from being run over or crushed. Keep foldable ROPS systems in "locked up" position at all times.**
- **Remove accumulated debris from this equipment, power unit, and engine to avoid fire hazard.**
- **Make sure all safety decals are installed. Replace if damaged. (See Safety Decals section for location.)**
- **Make sure shields and guards are properly installed and in good condition. Replace if damaged.**
- **A minimum 20% of tractor and equipment weight must be on the tractor front wheels when attachments are in transport position. Without this weight, tractor could tip over, causing personal injury or death. The weight may be attained with a loader, front wheel weights, ballast in tires or front tractor weights. Weigh the tractor and equipment. Do not estimate.**
- **Inspect and clear area of stones, branches, or other hard objects that might be thrown, causing injury or damage.**

*(Safety Rules continued on next page)*

# SAFETY RULES



**ATTENTION! BECOME ALERT! YOUR SAFETY IS INVOLVED!**



*(Safety Rules continued from previous page)*

■ Air in hydraulic systems can cause erratic operation and allows loads or equipment components to drop unexpectedly. When connecting equipment or hoses or performing any hydraulic maintenance, purge any air in hydraulic system by operating all hydraulic functions several times. Do this before putting into service or allowing anyone to approach the equipment.

## OPERATION

- Keep bystanders away from equipment.
- Operate only in daylight or good artificial light.
- Never go underneath equipment (lowered to the ground or raised) unless it is properly blocked and secured. Never place any part of the body underneath equipment or between moveable parts even when the engine has been turned off. Hydraulic system leak down, hydraulic system failures, mechanical failures, or movement of control levers can cause equipment to drop or rotate unexpectedly and cause severe injury or death. Follow Operator's Manual instructions for working underneath and blocking requirements or have work done by a qualified dealer.
- Never direct discharge toward people, animals, or property.
- Full chain shielding, designed to reduce the possibility of thrown objects, must be installed when operating in populated areas or other areas where thrown objects could injure people or damage property. If this machine is not equipped with full chain shielding, operation must be stopped when anyone comes within 300 feet.
- Do not operate or transport equipment while under the influence of alcohol or drugs.
- Keep hands, feet, hair, and clothing away from equipment while engine is running. Stay clear of all moving parts.
- Always comply with all state and local lighting and marking requirements.
- Never allow riders on power unit or attachment.
- Power unit must be equipped with ROPS or ROPS cab and seat belt. Keep seat belt securely fastened. Falling off power unit can result in death from being run over or crushed. Keep foldable ROPS systems in "locked up" position at all times.
- Always sit in power unit seat when operating controls or starting engine. Securely fasten seat

belt, place transmission in neutral, engage brake, and ensure all other controls are disengaged before starting power unit engine.

- Operate tractor PTO at 540 RPM. Do not exceed.
- Look down and to the rear and make sure area is clear before operating in reverse.
- Do not operate or transport on steep slopes.
- Do not stop, start, or change directions suddenly on slopes.
- Use extreme care and reduce ground speed on slopes and rough terrain.
- Watch for hidden hazards on the terrain during operation.
- Stop power unit and equipment immediately upon striking an obstruction. Turn off engine, remove key, inspect, and repair any damage before resuming operation.

## TRANSPORTATION

- Power unit must be equipped with ROPS or ROPS cab and seat belt. Keep seat belt securely fastened. Falling off power unit can result in death from being run over or crushed. Keep foldable ROPS system in "locked up" position at all times.
- The maximum transport speed for towed and semi-mounted machines is 20 mph (32 km/h). Regardless of the maximum speed capability of the towing tractor, do not exceed the implement's maximum transport speed. Doing so could result in:
  - Loss of control of the implement and tractor
  - Reduced or no ability to stop during braking
  - Implement tire failure
  - Damage to the implement or its components.
- Always comply with all state and local lighting and marking requirements.
- Never allow riders on power unit or attachment.
- Do not operate PTO during transport.
- Do not operate or transport on steep slopes.
- Do not operate or transport equipment while under the influence of alcohol or drugs.
- Never tow this implement with a motor vehicle.

## MAINTENANCE

- Before performing any service or maintenance, lower equipment to ground or block securely, turn off engine, remove key, and disconnect driveline from tractor PTO.



# SAFETY RULES



**ATTENTION! BECOME ALERT! YOUR SAFETY IS INVOLVED!**



- Do not modify or alter or permit anyone else to modify or alter the equipment or any of its components in any way.
- Always wear relatively tight and belted clothing to avoid entanglement in moving parts. Wear sturdy, rough-soled work shoes and protective equipment for eyes, hair, hands, hearing, and head; and respirator or filter mask where appropriate.
- Never go underneath equipment (lowered to the ground or raised) unless it is properly blocked and secured. Never place any part of the body underneath equipment or between moveable parts even when the engine has been turned off. Hydraulic system leak down, hydraulic system failures, mechanical failures, or movement of control levers can cause equipment to drop or rotate unexpectedly and cause severe injury or death. Follow Operator's Manual instructions for working underneath and blocking requirements or have work done by a qualified dealer.
- Make sure attachment is properly secured, adjusted, and in good operating condition.
- Keep all persons away from operator control area while performing adjustments, service, or maintenance.
- Make certain all movement of equipment components has stopped before approaching for service.
- Frequently check blades. They should be sharp, free of nicks and cracks, and securely fastened.
- Your dealer can supply genuine replacement blades. Substitute blades may not meet original equipment specifications and may be dangerous.
- Make sure shields and guards are properly installed and in good condition. Replace if damaged.
- Tighten all bolts, nuts and screws to torque chart specifications. Check that all cotter pins are installed securely to ensure equipment is in a safe condition before putting unit into service.
- Make sure all safety decals are installed. Replace if damaged. (See Safety Decals section for location.)
- Do not handle blades with bare hands. Careless or improper handling may result in serious injury.
- Explosive separation of tire and rim parts can cause serious injury or death. Release all air pressure before loosening bolts.

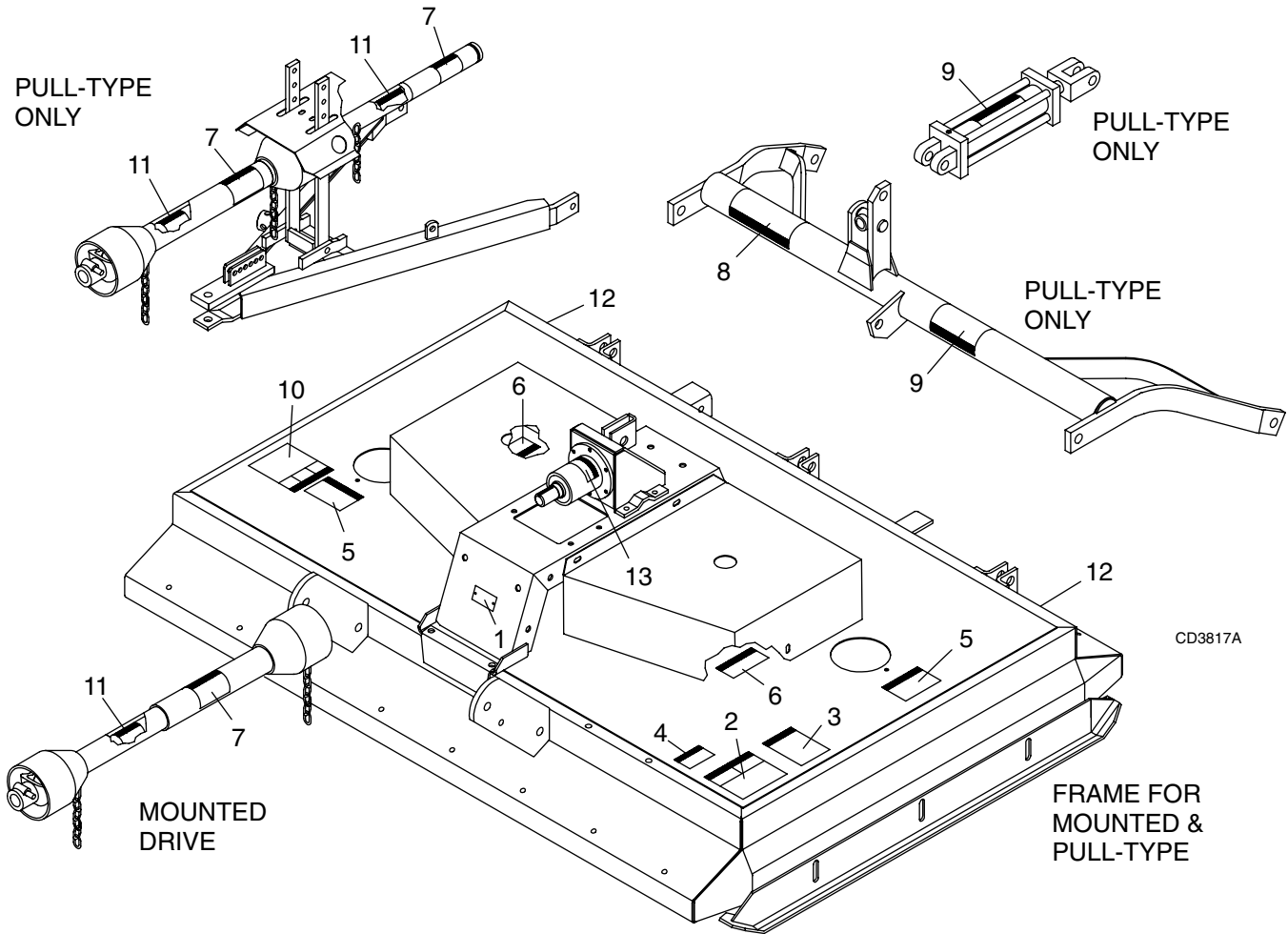
## STORAGE

- Raise cutter and block securely. Block wheels and raise tongue with jack. Disconnect hydraulic lines to optional cylinder. Disconnect driveline and secure up off the ground.
- Keep children and bystanders away from storage area.
- Store on level, solid ground.
- Follow manual instructions for storage.

# SAFETY & INSTRUCTIONAL DECALS



**ATTENTION! BECOME ALERT! YOUR SAFETY IS INVOLVED!**  
**Replace Immediately If Damaged!**



## 1 - SERIAL NUMBER PLATE



2 - 18865

<b>WARNING</b>	
<p><b>FALLING OFF CAN RESULT IN BEING RUN OVER.</b></p> <ul style="list-style-type: none"> <li>■ Tractor must be equipped with ROPS (or ROPS CAB) and seat belt. Keep foldable ROPS systems in "locked up" position at all times.</li> <li>■ Buckle Up! Keep seat belt securely fastened.</li> <li>■ Allow no riders.</li> </ul>	
<p><b>RAISED EQUIPMENT CAN DROP AND CRUSH.</b></p> <ul style="list-style-type: none"> <li>■ Before working underneath, follow all instructions and safety rules in operator's manual and securely block up all corners of equipment with jack stands.</li> <li>■ Securely blocking prevents equipment dropping from hydraulic leak-down, hydraulic system failures or mechanical component failures.</li> </ul>	
<p><b>FALLING OFF OR FAILING TO BLOCK SECURELY CAN RESULT IN SERIOUS INJURY OR DEATH.</b></p> <p style="text-align: right; font-size: small;">18865-C</p>	

4 - 18866

<b>WARNING</b>
<p><b>DO NOT EXCEED PTO SPEED OF 540 RPM</b></p> <p>PTO speeds higher than 540 RPM can cause equipment failure and personal injury.</p> <p style="text-align: right; font-size: small;">18866-D</p>



# SAFETY & INSTRUCTIONAL DECALS

**ATTENTION! BECOME ALERT! YOUR SAFETY IS INVOLVED!**  
**Replace Immediately If Damaged!**



3 - 18877

<b>! WARNING</b>
<p><b>TO AVOID SERIOUS INJURY OR DEATH:</b></p> <ul style="list-style-type: none"> <li>■ Read Operator's Manual (available from dealer) and follow all safety precautions.</li> <li>■ Keep all shields in place and in good condition.</li> <li>■ Operate mower from tractor seat only.</li> <li>■ Lower mower, stop engine and remove key before dismounting tractor.</li> <li>■ Allow no children or untrained persons to operate equipment.</li> <li>■ Do not transport towed or semi-mounted units over 20 mph.</li> </ul> <p style="text-align: center;"><b>FAILURE TO OPERATE SAFELY CAN RESULT IN INJURY OR DEATH.</b></p> <p style="text-align: right; font-size: small;">18877-C</p>

11- 33347

<b>! DANGER</b>

<b>GUARD MISSING. DO NOT OPERATE.</b>
<b>! DANGER</b>

<b>GUARD MISSING. DO NOT OPERATE.</b>
<b>! DANGER</b>

7 - 18864

<b>! DANGER</b>

<p><b>ROTATING DRIVELINE CONTACT CAN CAUSE DEATH</b>  <b>KEEP AWAY!</b></p> <p><b>DO NOT OPERATE WITHOUT -</b></p> <ul style="list-style-type: none"> <li>■ All driveline guards, tractor and equipment shields in place</li> <li>■ Drivelines securely attached at both ends</li> <li>■ Driveline guards that turn freely on driveline</li> </ul> <p style="text-align: right; font-size: small;">18864-C</p>

6 - 18867

<b>! DANGER</b>
<p><b>SHIELD MISSING</b></p> <p><b>DO NOT OPERATE</b>  <b>PUT SHIELD ON</b></p> <p style="text-align: right; font-size: small;">18867-B</p>


5 - 15502

<b>! WARNING</b>
<p><b>ROTATING COMPONENTS</b></p> <p>Do not operate without cover in place. Look and listen for rotation. Do not open cover until all components have stopped.</p> <p><b>CONTACT WITH ROTATING PARTS CAN CAUSE SERIOUS INJURY.</b></p> <p style="text-align: right; font-size: small;">15502-B</p>

8 - 15951

<b>! WARNING</b>	
	<p><b>A RAISED CUTTER CAN DROP AND CRUSH</b></p> <ul style="list-style-type: none"> <li>■ Cutter must have crank with pin installed to prevent crank detachment.</li> <li>■ Before working underneath, rotate crank to highest position and block up cutter.</li> <li>■ Blocking up prevents cutter dropping from hydraulic leak down, hydraulic system failures, or mechanical component failures.</li> </ul> <p><b>FAILURE TO FOLLOW INSTRUCTIONS CAN RESULT IN SERIOUS INJURY OR DEATH.</b></p>
	 <p style="text-align: center; font-size: small;">CYLINDER AND CRANK REQUIREMENTS</p> <p style="text-align: right; font-size: x-small;">15951-B</p>

9 - 19924

	<table border="1" style="width: 100%; border-collapse: collapse;"> <tr> <td style="text-align: center; background-color: black; color: white; padding: 5px;"><b>! WARNING</b></td> </tr> <tr> <td style="padding: 5px;"> <p><b>HIGH-PRESSURE HYDRAULIC OIL LEAKS CAN PENETRATE SKIN RESULTING IN SERIOUS INJURY, GANGRENE OR DEATH.</b></p> <ul style="list-style-type: none"> <li>■ Check for leaks with cardboard; never use hand.</li> <li>■ Before loosening fittings: lower load, release pressure, and be sure oil is cool.</li> <li>■ Consult physician immediately if skin penetration occurs.</li> </ul> </td> </tr> </table> <p style="text-align: right; font-size: x-small;">19924-B</p>	<b>! WARNING</b>	<p><b>HIGH-PRESSURE HYDRAULIC OIL LEAKS CAN PENETRATE SKIN RESULTING IN SERIOUS INJURY, GANGRENE OR DEATH.</b></p> <ul style="list-style-type: none"> <li>■ Check for leaks with cardboard; never use hand.</li> <li>■ Before loosening fittings: lower load, release pressure, and be sure oil is cool.</li> <li>■ Consult physician immediately if skin penetration occurs.</li> </ul>
<b>! WARNING</b>			
<p><b>HIGH-PRESSURE HYDRAULIC OIL LEAKS CAN PENETRATE SKIN RESULTING IN SERIOUS INJURY, GANGRENE OR DEATH.</b></p> <ul style="list-style-type: none"> <li>■ Check for leaks with cardboard; never use hand.</li> <li>■ Before loosening fittings: lower load, release pressure, and be sure oil is cool.</li> <li>■ Consult physician immediately if skin penetration occurs.</li> </ul>			

**12 - RED REAR REFLECTOR 4.5" PN 20106**



# SAFETY & INSTRUCTIONAL DECALS

**ATTENTION! BECOME ALERT! YOUR SAFETY IS INVOLVED!**



**Replace Immediately If Damaged!**

10 - 15503

13 - 18869

<b>! DANGER</b>			
<b>ROTATING BLADES AND THROWN OBJECTS</b>			
<ul style="list-style-type: none"> <li>■ Do not put hands or feet under or into mower when engine is running.</li> <li>■ Before mowing, clear area of objects that may be thrown by blade.</li> <li>■ Keep bystanders away.</li> <li>■ Keep guards in place and in good condition.</li> </ul>			
<b>BLADE CONTACT OR THROWN OBJECTS CAN CAUSE SERIOUS INJURY OR DEATH.</b>			
<small>15503-C</small>			

<b>! DANGER</b>
<b>SHIELD MISSING</b>
<b>DO NOT OPERATE - PUT SHIELD ON</b>
<small>18869-B</small>

## BE CAREFUL!

Use a clean, damp cloth to clean safety decals.

Avoid spraying too close to decals when using a pressure washer; high-pressure water can enter through very small scratches or under edges of decals causing them to peel or come off.

Replacement safety decals can be ordered free from your Woods dealer. To locate your nearest dealer, check the Dealer Locator at [www.WoodsEquipment.com](http://www.WoodsEquipment.com), or in the United States and Canada call 1-800-319-6637.

PN - 1006348

<b>! WARNING</b>	<b>EXPLOSION HAZARD</b>
<b>RELEASE ALL AIR PRESSURE BEFORE LOOSENING BOLTS. FAILURE TO DO SO COULD RESULT IN SERIOUS INJURY.</b>	
<small>MAX. SPEED: 20 MPH, MAX. WEIGHT: 4000 LBS., MAX AIR PRESSURE: 40 PSI</small>	

# OPERATION

The designed and tested safety of this machine depends on it being operated within the limitations as explained in this manual. Be familiar with and follow all safety rules in the manual, on the cutter and on the tractor.

The safe operation of this cutter is the responsibility of the operator, who must be properly trained. The operator should be familiar with the equipment and all safety practices before starting operation. Read the Safety Rules and decals on page 7 through page 12.

Information specific to attaching or operating the mounted or towed unit will be identified in the text. Information applicable to either unit will not be segregated.

This cutter is designed for shredding heavy brush, such as prunings in orchards, groves and vineyards. Other applications include topping onion sets and potatoes before harvesting. It may also be used to shred green manure crops, straw and stubble, asparagus residue etc. prior to plowing. Recommended tractor ground speed for most mowing conditions is from 1 to 5 mph. Always operate tractor PTO at 540 rpm.

## DANGER

■ Full chain shielding, designed to reduce the possibility of thrown objects, must be installed when operating in populated areas or other areas where thrown objects could injure people or damage property. If this machine is not equipped with full chain shielding, operation must be stopped when anyone comes within 300 feet.

## WARNING

- Never allow children or untrained persons to operate equipment.
- Keep bystanders away from equipment.
- Before performing any service or maintenance, lower equipment to ground or block securely, turn off engine, remove key, and disconnect driveline from tractor PTO.
- On pull-type units, a pin is installed to prevent the height adjustment crank from detaching. Do not operate or service unit unless pin is installed.
- Keep all persons away from operator control area while performing adjustments, service, or maintenance.

## CAUTION

- Always wear relatively tight and belted clothing to avoid getting caught in moving parts. Wear sturdy, rough-soled work shoes and protective equipment for eyes, hair, hands, hearing, and head; and respirator or filter mask where appropriate.
- Make sure spring-activated locking pin or collar slides freely and is seated firmly in tractor PTO spline groove.
- Stop power unit and equipment immediately upon striking an obstruction. Turn off engine, remove key, inspect, and repair any damage before resuming operation.

## TRACTOR STABILITY

## WARNING

- A minimum 20% of tractor and equipment weight must be on the tractor front wheels when attachments are in transport position. Without this weight, tractor could tip over, causing personal injury or death. The weight may be attained with a loader, front wheel weights, ballast in tires or front tractor weights. Weigh the tractor and equipment. Do not estimate.

## ATTACHING MOUNTED CUTTER TO TRACTOR

## WARNING

- Make sure spring-activated locking pin or collar slides freely and is seated firmly in tractor PTO spline groove.

## MD80 Mounting

Standard Category 1 mounting pins are used when attaching cutter to tractor. Also available for mounting are optional Category 2 pins and a bushing kit.

Check to be sure mounting pins are properly torqued - Category 1: 300 lbs-ft.; Category 2: 450 lbs-ft.

Install tractor lower lift arms over the cutter mounting pins. Attach tractor top link in top hole of cutter A-frame. Use bushing over top link clevis pin when mounting on a Category 2 tractor.

## Driveline Attachment

Attach the cutter to the tractor 3-point hitch (or quick hitch if available). Do not attach driveline. Raise and lower cutter to determine maximum and minimum distance between the tractor PTO shaft and the gearbox input shaft. If the distance is too large, the driveline will be too short for proper engagement. If distance is too small, the driveline may bottom out in operation and damage the cutter or tractor.

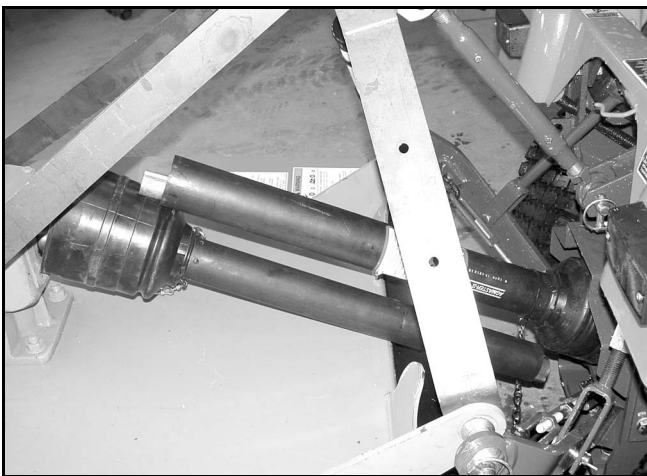
Driveline length must be sufficient to provide at least 1/3 driveline length of engagement during operation. There must be at least 4 inches of engagement at the cutters lowest possible point of operation. The driveline must not bottom out when raised to the maximum height possible.

If driveline is too short please call your Woods dealer for a longer driveline.

If driveline is too long please follow the instructions for shortening the driveline.

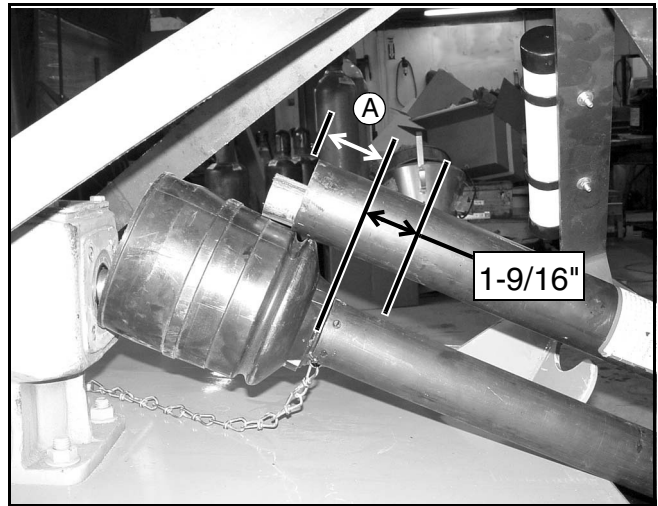
## Shorten Driveline

1. Move cutter up and down to get the shortest possible distance between tractor PTO shaft and gearbox input shaft.
2. Separate driveline into two halves and connect them to the tractor PTO and gearbox.
3. Place driveline halves parallel to one another to determine how much to shorten the driveline.



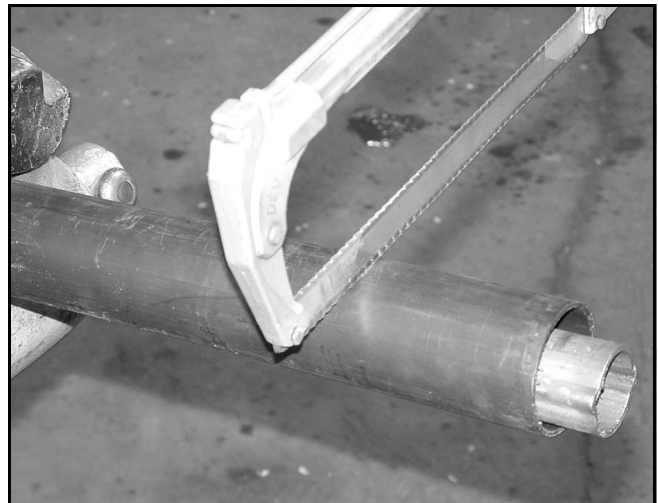
**Figure 1.** Drive Halves Placed Parallel

4. Measure from end of the upper shield to the base of the bell on the lower shield (A). Add 1-9/16" to dimension (A). See Figure 2.



**Figure 2.** Determine Shield Length

5. Cut the shield to the overall dimension.



**Figure 3.** Cut Shield

6. Place the cutoff portion of the shield against the end of the shaft and use as a guide. Mark and cut the shaft.



**Figure 4.** Cut Shaft to Length

7. Repeat step 6 for the other half of the drive.
8. File and clean cut ends of both drive halves.

Do not use tractor if proper driveline engagement cannot be obtained through these methods.

Connect driveline to tractor PTO shaft, making sure the spring-activated locking collar slides freely and locks driveline to PTO shaft.

### NOTICE

■ If attaching with quick hitch the distance between the tractor PTO and gearbox input shaft will increase. Please follow the steps as you would for a 3-point hitch to insure proper engagement.

### Cutting Height Adjustment for MD80 Mounted Cutter

Place tractor and cutter on a level surface.

The adjustments given here are to provide you with a starting point. Adjustments are approximate and may vary due to slight differences in blade shimming and machine wear. You may desire to fine tune them for your situation.

### ⚠ WARNING

- Keep all persons away from operator control area while performing adjustments, service, or maintenance.
- Avoid very low cutting heights. Striking the ground with blades produces one of the most damaging shock loads a cutter can encounter. Allowing blades to contact ground repeatedly, will cause damage to cutter and drive.

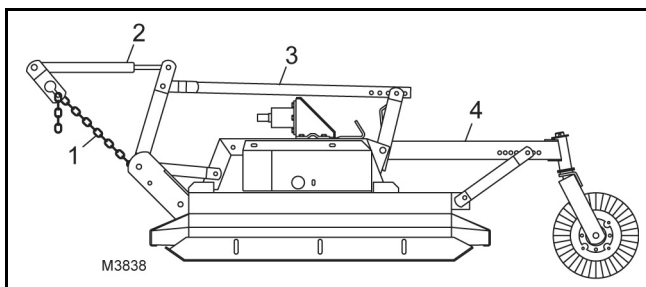


Figure 5. Cutting Height Adjustment - MD80 (Mounted Model)

Cutting height may be controlled by several methods. Without the optional check chains and tailwheel it is controlled with the tractor 3-point lift and top link adjustment.

Measure from front edge of cutter frame (on each side) to ground to be sure cutter is level. Use adjustment on 3-point arms, if necessary, for fine adjustment side to side.

When using optional check chains, install them in key-hole brackets. Count the links between the cutter and brackets to be sure you have the same number of links on each side. You may twist check chain for fine adjustment side to side.

### Cutting Height Adjustment Without Tailwheel or Check Chains

The blade is approximately 9-1/4" below the top of the cutter deck.

Select a cutting height, EXAMPLE 3".

Use tractor 3-point lift to set front blade 3" above level surface (measure 12-1/4" from top of deck to ground). At the rear, measure from top of deck to ground; adjust top link until this distance is from 12-3/4" to 13". Adjust lower stop of the tractor 3-point lift control. When adjustment is set, this will enable you to return to the preset cutting height.

Maintain distance from blade tip to level surface from 1/2" to 3/4" higher at rear for best cutting results and lowest power consumption.

When using cutter for shredding, it is better to set blade tip lower at the rear. How much lower depends on the material to be shredded. You will need to experiment to determine the best setting for your situation.

### Cutting Height Adjustment With Tailwheel or Check Chains

The blade is approximately 9-1/4" below the top of the cutter deck.

Select a cutting height, EXAMPLE 3".

Use check chains and tractor 3-point lift and raise top front of cutter deck 12-1/4" above the level surface. At the rear, measure from top of deck to ground; adjust tailwheel until this distance is from 12-3/4" to 13".

Shorten the check chains to raise front of cutter. Move tailwheel adjustment to the rear to raise rear of cutter.

### ATTACHING PULL-TYPE CUTTER TO TRACTOR

The cutter is shipped with a 1-3/8" PTO spline. The horizontal distance between the end of the tractor PTO shaft and the drawbar hitch point should be 14". This distance must not vary more than plus or minus one inch ( $\pm 1$ " ) or the drive may be damaged when turning. Adjust tractor drawbar to obtain the desired drawbar to hitch point distance. On some tractors, a drawbar kit must be used to obtain the required dimension. Check with your tractor dealer if you encounter problems.

Raise cutter tongue to tractor drawbar height with jack provided and attach with a 3/4" or larger high-strength drawbar pin. Retain pin to keep it in place.

Connect cutter driveline to tractor PTO shaft, making sure the spring-activated locking pin slides freely and is seated firmly in tractor PTO spline groove.

Adjust H-frame bearing height to ensure front driveline is parallel to ground.

Remove parking jack from tongue. Attach to frame rail storage with top forward. Always attach jack to tongue to hold it up when disconnecting it from tractor.

Adjust drive shaft carrier bearing (2), Figure 6, vertically in H-frame until driveline is as straight as possible between tractor PTO and cutter gearbox.

## Cutting Height Adjustment for D80 Pull-Type Cutter

Place tractor and cutter on a level surface.

Cutting height is raised and lowered with height adjustment crank (3) or optional hydraulic cylinder. Front to rear attitude is set with the compression link (1). See Figure 6.

The blade is approximately 9-1/4" below cutter deck.

Select a cutting height, EXAMPLE 3".

Raise front end of deck with a jack to take the compression member (1) out of compression and remove the bolt connecting it to the tongue.

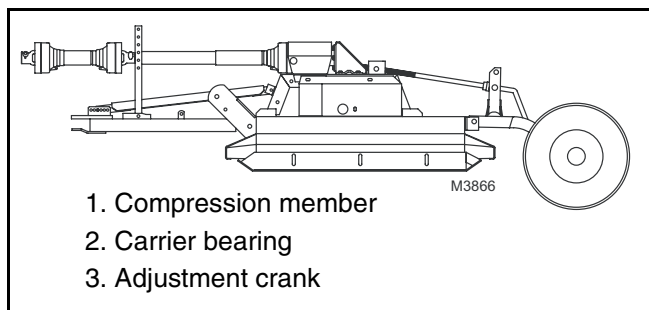
Raise front end of deck until both sides are 12-1/4" above the ground and block underneath to maintain this distance.

Raise rear end of deck until it is from 13-3/4" to 14" above the ground.

Connect compression member (1) to tongue. It may be necessary to raise or lower rear of deck to align hole.

Remove the blocks from under the deck and position each side skid 1/2" above the ground.

This complete procedure must be followed to properly set a new cutting height. Raising rear of deck with crank without changing the compression link position will result in an incorrect front-to-rear attitude setting.



**Figure 6.** Cutting Height Adjustment - D80 (Pull-Type Model)

## **PRE-OPERATION CHECK LIST**

### **(Owner's Responsibility)**

- \_\_\_ Check that cutter is properly and securely attached to tractor.
- \_\_\_ Make sure driveline spring-activated locking pin slides freely and is seated firmly in tractor PTO spline groove.
- \_\_\_ On pull-type cutter, make sure the pin to prevent crank detachment is installed.
- \_\_\_ Set tractor PTO at 540 rpm.
- \_\_\_ Make sure gearbox is full to fill plug with SAE 90W gear lube.
- \_\_\_ Lubricate all grease fitting locations.
- \_\_\_ Check that all hardware is properly installed and secured.
- \_\_\_ Check to ensure blades are sharp and secure and cutting edge is positioned to lead in a counter-clockwise rotation.
- \_\_\_ Check that all shields and guards are properly installed and in good condition.
- \_\_\_ Check cutting height and attitude adjustment.
- \_\_\_ Place tractor PTO and transmission in neutral before attempting to start engine.
- \_\_\_ Inspect area to be cut and remove stones, branches or other hard objects that might be thrown, causing injury or damage.
- \_\_\_ Inspect chain shielding and replace any damaged or missing links.

## **STARTING AND STOPPING CUTTER**

Cutter operating power is supplied from tractor PTO. Refer to your tractor manual for PTO engagement and disengagement instructions. Always operate PTO at 540 rpm. Know how to stop tractor and cutter quickly in case of an emergency.

When engaging PTO, the engine rpm should always be low. Once engaged and ready to start cutting, raise PTO speed to 540 rpm and maintain throughout cutting operation.

## **OPERATING TECHNIQUE**

Proper ground speed will depend upon the height, type and density of material to be cut.

Normally, ground speed will range from 2 to 5 mph. Tall dense material should be cut at a low speed, while thin medium-height material can be cut at a higher ground speed.

Always operate PTO at 540 rpm; this is necessary to maintain proper blade speed and produce a clean cut.



Under certain conditions, tractor tires may roll some material down and prevent it from being cut at the same height as the surrounding area. When this occurs, reduce tractor ground speed but maintain 540 rpm PTO speed. The lower speed will permit material to at least partially rebound.

Under some conditions, material will not rebound enough to be cut evenly, resulting in an uneven appearance. In general, lower cutting heights give a more even cut with less tendency to leave tire tracks.

The cutter is equipped with general purpose suction blades as standard equipment. These blades are intended for most conditions.

Optional flat blades for light brush cutting and optional high fin blades for stalk shredding are available from your dealer.

## Tips

Extremely tall material should be cut twice. Cut material higher the first pass. Then cut at desired height, at 90° to first pass.

Remember, sharp blades produce cleaner cuts and require less power.

Analyze area to be cut to determine best procedure. Consider height and type of material and terrain type: hilly, level or rough.

Plan your pattern to travel straight forward whenever possible.

## WARNING

- **Inspect and clear area of stones, branches, or other hard objects that might be thrown, causing injury or damage.**

### Uneven Terrain

## WARNING

- **Do not operate or transport on steep slopes.**
- **Do not stop, start, or change directions suddenly on slopes.**
- **Use extreme care and reduce ground speed on slopes and rough terrain.**
- **Watch for hidden hazards on the terrain during operation.**

Pass diagonally through sharp dips and avoid sharp drops to prevent hanging up tractor and cutter.

Practice will improve your skills in maneuvering rough terrain.

## STORAGE

Follow these steps when storing your cutter:

1. Store on level, solid ground.
2. Disconnect driveline and secure up off the ground.
3. On pull-type model, attach parking jack and raise tongue weight off tractor drawbar.
4. Securely block all four corners of deck with jack stands.
5. Remove hydraulic hoses after tractor is turned off and all system pressure is released by operating valve levers several times.
6. Remove retainer pin and high strength drawbar pin.
7. Keep children and bystanders away from storage area.

# OWNERS SERVICE

## WARNING

■ On pull-type units, a pin is installed to prevent the height adjustment crank from detaching. Do not operate or service unit unless pin is installed.

■ Before performing any service or maintenance, lower equipment to ground or block securely, turn off engine, remove key, and disconnect driveline from tractor PTO.

■ Keep all persons away from operator control area while performing adjustments, service, or maintenance.

## CAUTION

■ Always wear relatively tight and belted clothing to avoid getting caught in moving parts. Wear sturdy, rough-soled work shoes and protective equipment for eyes, hair, hands, hearing, and head; and respirator or filter mask where appropriate.

The information in this section is written for operators who possess basic mechanical skills. Should you need help, your dealer has trained service technicians available. For your protection, read and follow all safety information in this manual.

## LUBRICATION INFORMATION

The accompanying chart gives the frequency of lubrication in operating hours, based on normal conditions. Severe or unusual conditions may require more frequent lubrication. See Figure 8.

Do not let excess grease collect on or around parts, particularly when operating in sandy areas.

Use an SAE 90W gear lube in gearbox.

Use a lithium grease of No. 2 consistency with a MOLY (molybdenum disulfide) additive for all locations. Be sure to clean fittings thoroughly before attaching grease gun. When applied according to the lubrication chart, one good pump of most guns is sufficient. Do not overgrease.

Daily lubrication of the PTO slip joint is necessary. Failure to maintain proper lubrication can result in damage

to U-joints, gearbox, tractor PTO and/or cutter driveline.

## BLADE SERVICING

## WARNING

■ On pull-type units, a pin is installed to prevent the height adjustment crank from detaching. Do not operate or service unit unless pin is installed.

Blocking the cutter before working underneath provides additional safety. If a mechanical or hydraulic failure occurs, the blocks will support the cutter and prevent anyone under it from being crushed.

Inspect blades, each time before operating cutter, for condition and proper installation. Check to be sure blades are snug but still swivel on blade pin (see Blade Installation, page 20). Replace any blade that is bent, excessively nicked, worn or has any other damage. Small nicks can be ground out when sharpening.

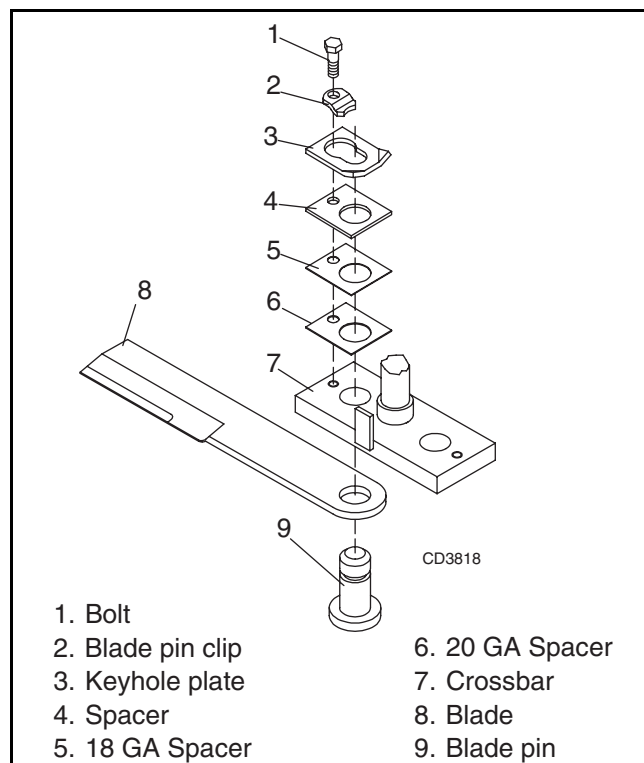
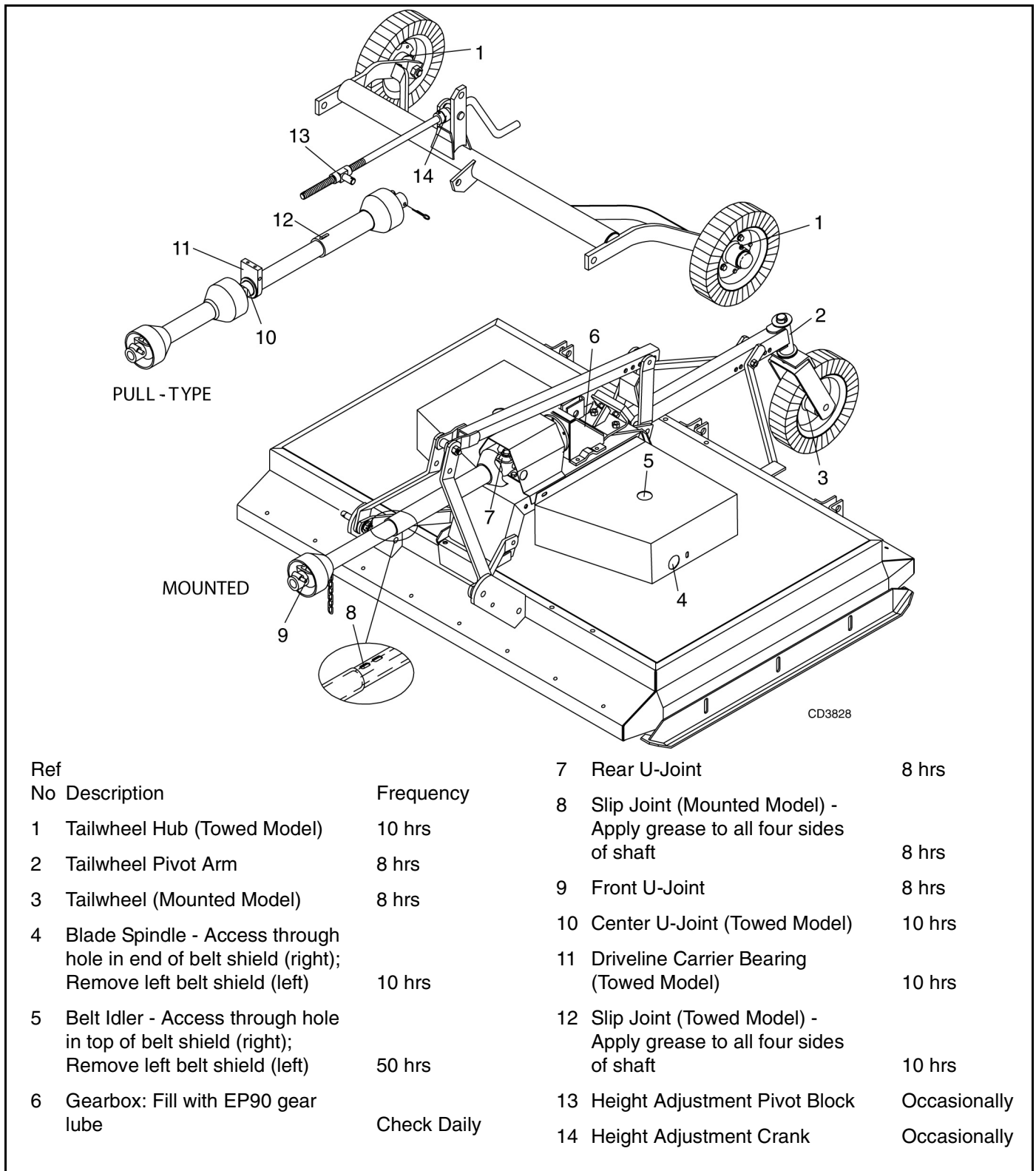


Figure 7. Blade Removal & Installation



**Figure 8.** Lubrication Points

### Blade Removal

Rotate crossbar until blade pin assembly is directly below access hole in rear of cutter frame. Remove bolt

(1) and blade pin clip (2). Slide keyhole plate (3) out of blade pin groove and remove. Remove spacers and drive pin out of crossbar. See Figure 7.

## NOTICE

- If blade pin is seized in crossbar and extreme force will be required to remove it, support crossbar from below to prevent damage to spindle.



- Your dealer can supply genuine replacement blades. Substitute blades may not meet original equipment specifications and may be dangerous.

### Blade Installation

Always replace both blades at the same time to maintain balance.

Liberally coat blade pin and crossbar hole with Never-Seez® or equivalent. Make sure blade is offset away from deck and cutting edge is positioned for counter-clockwise rotation.

Install blade pin (9) up through blade (8) then through hole in crossbar and push firmly against crossbar (7). Install as many spacers (4, 5 or 6) as possible and still be able to slide keyhole plate (3), with ears up as shown, into blade pin groove. Place blade pin clip (2) over keyhole plate and into blade pin groove. Secure with bolt (1). Repeat for opposite blade. See Figure 7.

Blade should be snug but swivel on pin without excessive force. Retain any spacers not used in installation for use when blade wears or on future installations.

### Blade Sharpening

Always sharpen both blades at the same time to maintain balance. Follow original sharpening pattern. Do not sharpen blade to a razor edge. Leave from a 1/16" to 1/8" blunt edge. Do not sharpen back side of blade.

### Belt Installation

One of the major causes of belt failure is improper installation.

Before new belts are installed, check pulley shafts and bearings for wear. Check pulley grooves for cleanliness and wear. Be sure they turn freely and with only slight wobble. If grooves require cleaning, moisten a cloth

with a non-flammable, non-toxic degreasing agent or commercial detergent and water.

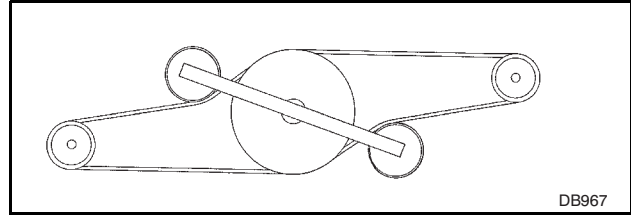


Figure 9. Belt Routing

Avoid excessive force during installation. Do not use tools to pry belt into pulley groove. Do not roll belt over pulleys to install. This can cause hidden damage and premature belt failure. Always loosen idlers when installing belts.

The drive on this cutter uses three belts. They are a matched set and must be replaced as such.

Remove belt shields.

Loosen nut on idler adjustment rod (located on right side of gearbox stand) as loose as possible.

Remove old belts and install new ones. Tighten nut on idler adjustment rod. Belts should be very tight.

## NOTICE

- Check tension on new belts every half hour the first four hours of operation and then every eight hours.

### CHAIN SHIELDING



- Full chain shielding, designed to reduce the possibility of thrown objects, must be installed when operating in populated areas or other areas where thrown objects could injure people or damage property. If this machine is not equipped with full chain shielding, operation must be stopped when anyone comes within 300 feet.



- Inspect chain, rubber, or steel band shielding before each use. Replace if damaged.

## **SERVICING TIRES SAFELY**

### **Used Aircraft Tires (Figure 10)**

#### **⚠ WARNING**



■ Explosive separation of tire and rim parts can cause serious injury or death. Release all air pressure before loosening bolts.

Do not attempt to mount a tire unless you have the proper equipment and experience to perform the job.

Always maintain the correct tire pressure. Do not inflate tires above the recommended pressure. Never weld or heat a wheel and tire assembly. The heat can cause an increase in air pressure and result in a tire explosion. Welding can structurally weaken or deform the wheel.

When inflating tires, use a clip-on chuck and an extension hose long enough to allow you to stand to the side — not in front of or over the tire assembly. Use a safety cage if available.

Check wheels for low pressure, cuts, bubbles, damaged rims, or missing lug bolts and nuts.

Never remove split rim assembly hardware (A) with the tire inflated.



**Figure 10.** Split Rim Tire Servicing

# DEALER SERVICE

## WARNING

- On pull-type units, a pin is installed to prevent the height adjustment crank from detaching. Do not operate or service unit unless pin is installed.
- Before performing any service or maintenance, lower equipment to ground or block securely, turn off engine, remove key, and disconnect driveline from tractor PTO.
- Keep all persons away from operator control area while performing adjustments, service, or maintenance.

## CAUTION

- Always wear relatively tight and belted clothing to avoid getting caught in moving parts. Wear sturdy, rough-soled work shoes and protective equipment for eyes, hair, hands, hearing, and head; and respirator or filter mask where appropriate.

The information in this section is written for dealer service personnel. The repair described herein requires special skills and tools. If your shop is not properly equipped or your mechanics are not properly trained in this type of repair, you may be time and money ahead to replace complete assemblies.

## **GEARBOX MAINTENANCE**

Before beginning any gearbox repair, please read this entire section. Many steps are dependent on each other.

Always make sure proper vent plug is installed in top of gearbox. Proper gear lube level for gearbox is half full. Never operate cutter unless gearbox is half full of SAE 90W gear lube.

Troubleshooting is an important part of gearbox maintenance. Check for leakage and bad bearings.

### **Bearing Check**

Bearing maladjustment or failure is indicated by excessive noise and noticeable side or end play in gear shafts.

### **Possible Leakage Causes**

Leakage may be caused by an improperly operating vent plug. The plug has a check valve in it; remove and apply very low pressure air to the bottom to check for proper venting.

Check housing for visible signs of leakage.

Check for leaks at vertical and horizontal seals and gaskets.

Take necessary corrective action and clean area where leakage was evident. Place cutter in service and check to ensure leakage has stopped.

### **Leakage Repair**

Permatex Aviation 3D Form-A-Gasket® or equivalent is the recommended sealant for gearbox repair.

Leakage at the horizontal seal or gasket can be corrected without removing gearbox from cutter.

Remove fill plug and siphon gear lube from gearbox. Remove and replace leaking seal or gasket. Refer to Seal Installation section, page 23.

### **Removing Gearbox from Cutter**

Remove nut from belt tension idler adjustment rod.

Remove belt shields. Remove belts.

The front gear stand bolts are tack welded in place. Loosen the nuts to protect bolt threads and break tack welds by rapping them with a hammer. Remove nuts and bolts.

Remove nuts from the rear gear stand bolts. Tip rear of gear stand up over bolts and slide the stand rearward.

Cut the safety wire and remove bolt from drive pulley under gearbox.

Disassemble split taper bushing (located on bottom of drive pulley) by removing the three bolts and inserting two of them into the threaded holes. Tighten alternately to press bushing off.

Remove the four gearbox attaching bolts from the gear stand and remove gearbox from stand.

### **Gearbox Disassembly**

(Refer to illustration on page 45.)

Remove the horizontal and vertical gear shaft housings from gearbox housing. Remove seals. Remove tack weld, holding sleeve to shaft, by grinding. Press gear and shaft from housing. Remove cups from housing.

### **Damage Inspection**

Inspect gears for excessive wear. Some wear is normal. Gears will show more wear on loaded side. They are forged and surfaces will appear rough, even when new. The wear pattern should be smooth.

Do not replace gears unless deep gouges, chips, deep pitting or deep wear grooves are present.

Inspect gear shafts and sleeves. Pay specific attention to areas where seals seat. Check for cracks, grooves, nicks or bumps. If damage cannot be repaired by resurfacing with emery cloth, replace damaged part.

Inspect housings for damage, paying specific attention where seals seat. Replace housing if damaged area cannot be resurfaced with emery cloth.

## **Gearbox Assembly**

(Refer to illustration on page 45.)

Bearing cups, cones and sleeves are a press fit.

Press new bearing cups into vertical and horizontal housings.

Press bearing cones onto vertical and horizontal shafts until they seat against machined surface next to gears.

Insert shafts into their respective housings and press bearing cones onto shaft until all free play is removed (similar to adjusting front wheel bearings on an automobile).

Check adjustment by spinning housing. It should turn freely. If bearings are too tight, hold housing and rap gear shaft with lead or brass hammer. Readjust bearings. Proper bearing adjustment is essential to good bearing life. Do not leave bearings adjusted too tight. Bearings should turn freely without any noticeable end play.

Place O-ring seal over shaft and seat against bearing. Press sleeve on shaft and down against bearing, but do not move bearing. Check bearing adjustment again by spinning housing. Readjust if necessary. Protect surfaces where seal seats and tack weld sleeve to shaft.

### **Seal Installation**

An improperly installed seal will leak and could result in gearbox failure.

Clean area in housing where outer diameter of seal seats and apply a thin coat of Permatex.

Lubricate seal lip, position spring toward housing, and carefully guide over sleeve and shaft, using a blunt tool such as a letter opener. Use care to prevent seal lip from rolling under. Do not use a knife blade as it will nick and ruin seal.

Select a piece of pipe or tubing with an OD that will set on outside edge of seal cage but will clear housing. A driver that is too small will bow cage and ruin seal.

Carefully press seal into housing, preventing distortion to metal seal cage. Seat seal firmly against housing.

## **Gearbox Adjustment**

Place a 1/32" thick gasket between the vertical and horizontal housing and gearbox housing. Horizontal housing must be positioned so breather hole is at top when gearbox is on cutter. Snug bolts and check gear mesh by shining a flashlight into the oil fill hole. The small ends of the teeth on both gears should be flush with each other and there should be some backlash.

If the gear teeth are not aligned, add gaskets under one of the gear housings until they do.

Use a feeler gauge to check for .020 backlash between the teeth. Adjust by adding or subtracting even numbers of gaskets of the same thickness from each housing and the gearbox.

When all of the bolts are tightened, check the backlash again to ensure it did not change. If it is changed, add or subtract gaskets as necessary to obtain .020 backlash between the teeth.

## **BLADE SPINDLE REPAIR**

Remove blades from crossbar and belts from pulley. Remove split taper bushing from pulley and remove pulley from spindle. Remove spindle from cutter. Remove set screw and flanged nut (1) from spindle, see Figure 11. Block under washer (9) and housing and press blade carrier and spindle shaft out of housing.

### **Assembly**

Press new cups (6) into spindle housing, seating them against housing bore shoulder, see Figure 11.

Place bottom end of spindle housing (18) up. Set bearing cone and sleeve (5) on cup.

Coat area of spindle housing where seal seats with Permatex. Press seal (4) (with spring-loaded lip toward the center) into housing, using care to prevent seal cage distortion.

Place washer (9) on spindle crossbar and shaft.

Remove bearing cones from housing.

Lubricate bottom seal, turn housing right side up and press down onto spindle shaft.

Fill housing cavity with a lithium grease of #2 consistency with a MOLY (molybdenum disulfide) additive.

Place washer (7) over shaft and seat. Seat bearing cone and sleeve (5) on bearing cup, see Figure 11.

Adjust bearings by pressing on shaft until all free play is removed (similar to adjusting front wheel bearings on an automobile).

Check adjustment by spinning housing; it should turn freely. If bearings are too tight, hold housing and rap spindle shaft with a lead hammer. Readjust bearings.

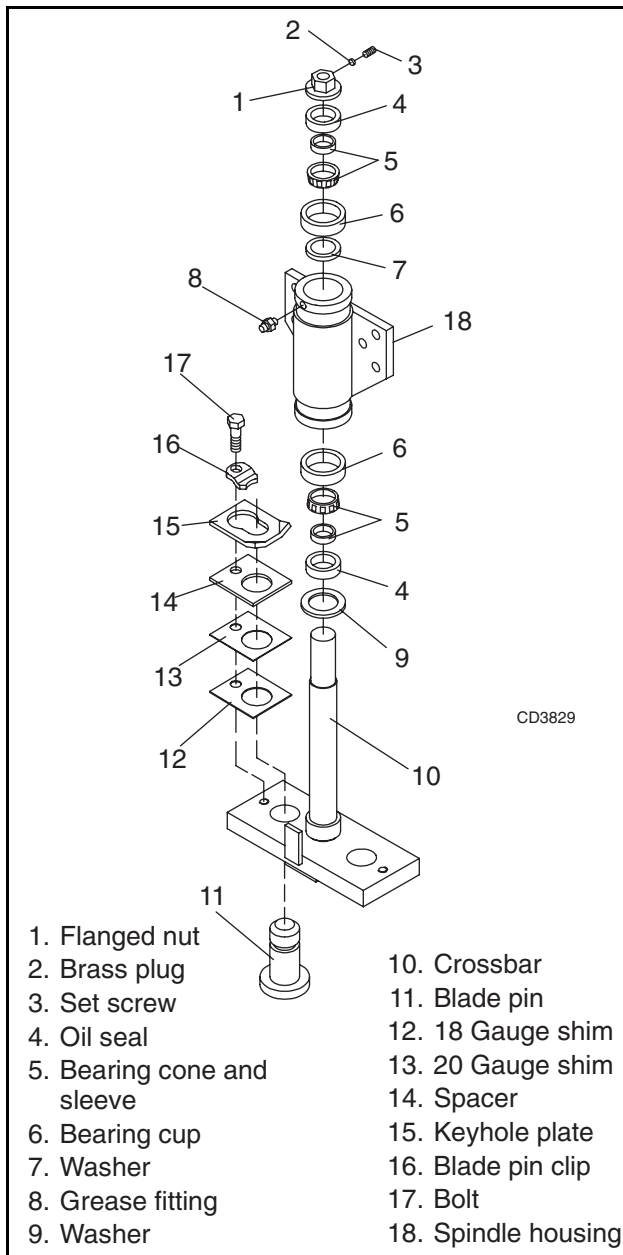
Proper bearing adjustment is essential to good bearing life. Do not leave bearing adjusted too tightly. Bearings should turn freely without any noticeable end play.

When the bearings are adjusted, coat area of spindle housing where seal seats with Permatex and press seal (4) (with spring-loaded lip up) into housing using care to prevent seal cage distortion.

When the bearings are adjusted, tighten nut against sleeve and bearing (5). Insert brass plug (2) into hole in nut then tighten set screw (3) against brass plug (2).

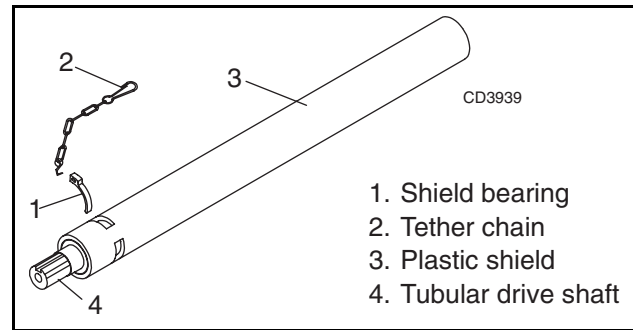
Grease spindle through grease fitting (8) until a small amount of grease escapes seal.

Install spindle on unit.



**Figure 11. Blade Spindle Assembly**

## **SHIELD BEARING SERVICE**

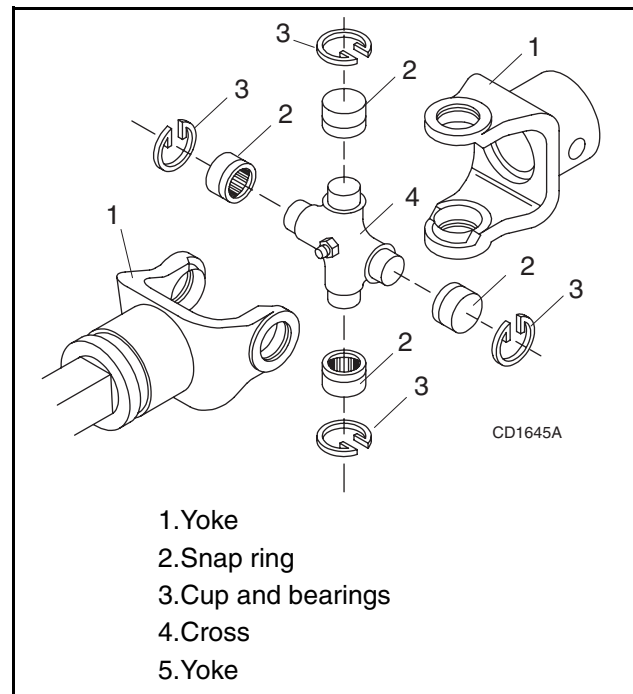


**Figure 12. Shield Bearing Service**

Remove shield bearings (1) by lifting up and pulling them out of the driveline groove.

When installing them, smear grease in the driveline groove and install all four bearings into the groove clockwise as shown in Figure 12.

## **UNIVERSAL JOINT REPAIR**

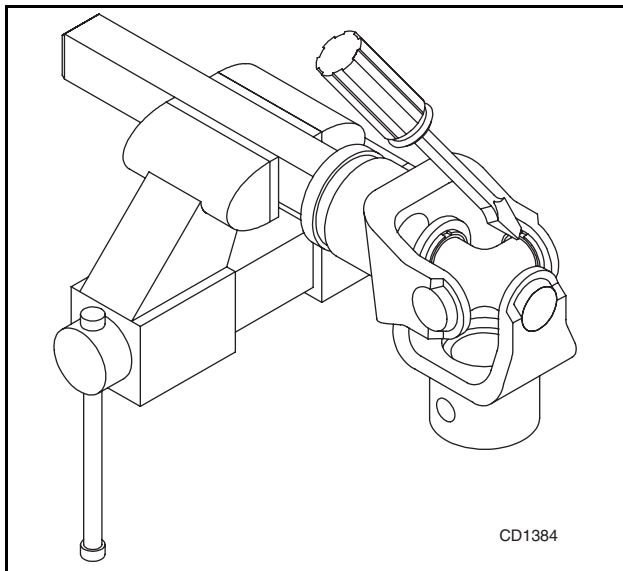


**Figure 13. U-Joint Exploded View**

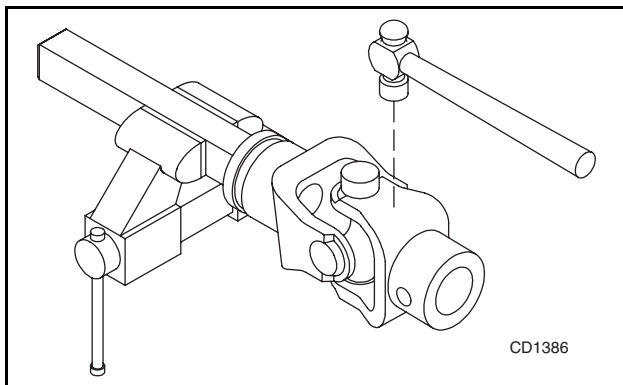
### **U-Joint Disassembly**

1. Remove snap rings from inside of yokes in four locations as shown in Figure 14.

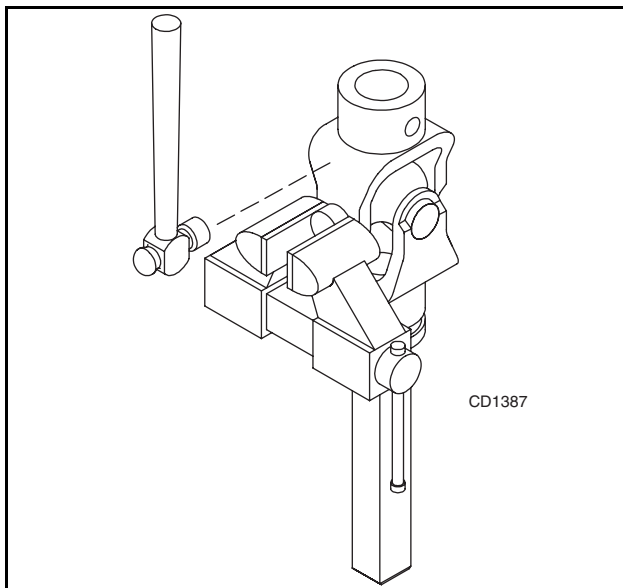




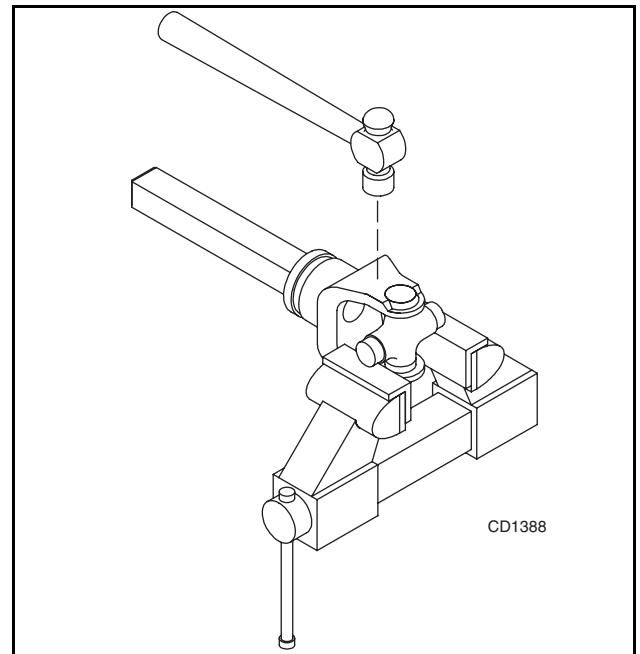
**Figure 14**



**Figure 15**



**Figure 16**



**Figure 17**

2. With snap rings removed, support drive in vise, hold yoke in hand and tap on yoke to drive cup out of yoke. See Figure 15.
3. Clamp cup in vise as shown in Figure 16 and tap on yoke to completely remove cup from yoke. Repeat steps two and three for opposite cup.
4. Place universal cross in vise as shown in Figure 17 and tap on yoke to remove cup. Repeat step three for final removal. Drive remaining cup out with a drift and hammer.

### U-Joint Assembly

1. Place seals securely on bearing cups. Insert cup into yoke from outside and press in with hand pressure as far as possible. Insert journal cross into bearing cup with grease fitting away from shaft. Be careful not to disturb needle bearings. Insert another bearing cup directly across from first cup and press in as far as possible with hand pressure.

Trap cups in vise and apply pressure. Be sure journal cross is started into bearings and continue pressure with vise, squeezing in as far as possible. Tap yoke to aid in process.

2. Seat cups by placing a drift or socket (slightly smaller than the cup) on cup and rapping with a hammer. See Figure 18. Install snap ring and repeat on opposite cup.
3. Repeat steps one and two to install remaining cups in remaining yoke.

Move both yokes in all directions to check for free movement. Should movement be restricted, rap on

yokes sharply with a hammer to relieve any tension. Repeat until both yokes move in all directions without restriction.

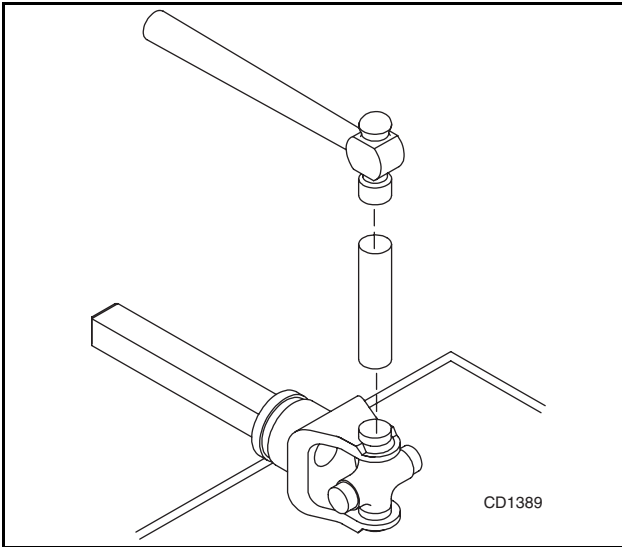


Figure 18

Always maintain the correct tire pressure. Do not inflate tires above the recommended pressure. Never weld or heat a wheel and tire assembly. The heat can cause an increase in air pressure and result in a tire explosion. Welding can structurally weaken or deform the wheel.

When inflating tires, use a clip-on chuck and an extension hose long enough to allow you to stand to the side — not in front of or over the tire assembly. Use a safety cage if available.

Check wheels for low pressure, cuts, bubbles, damaged rims, or missing lug bolts and nuts.

Never remove split rim assembly hardware (A) with the tire inflated.

### SERVICING TIRES SAFELY

Used Aircraft Tires (Figure 19)

**⚠ WARNING**



■ Explosive separation of tire and rim parts can cause serious injury or death. Release all air pressure before loosening bolts.

Do not attempt to mount a tire unless you have the proper equipment and experience to perform the job.



Figure 19. Split Rim Tire Servicing

# TROUBLE SHOOTING

PROBLEM	POSSIBLE CAUSE	SOLUTION
Does not cut	Dull blades	Sharpen blades.
	Worn or broken blades	Replace blades. (Replace in pairs only.)
	Ground speed too fast	Reduce ground speed.
	Drive not functioning (blades do not turn when PTO is running)	Check drive shaft connection. Check belts. Check gearbox.
	Belt off pulleys	Replace belts. Belts are supplied in matched sets only.
	Broken belt; belts not in groove	Replace belts. Check belts for uneven stretch.*
	Belts will not stay in groove	Check belt tension. Check belt alignment. Ensure idler bearings and spindle bearings are in good condition and turn freely. Make sure spindles are tight and sitting straight and secure. Shock loading could cause a worn belt to jump off grooves. Eliminate shock loading by raising cutting height.
	Belt tension too loose	Tighten idlers. Belts must be very tight.
	Gearbox malfunction	Repair gearbox.
Streaks or gives ragged cut	Broken or worn blades	Replace or sharpen blades.
	Ground speed too fast	Reduce ground speed.
	Excessive cutting height	Lower cutting height. (Note: Set height so unit does not frequently hit ground.)
	Excessive lush and tall vegetation	Recut at 90-degree to first pass.
Thrown objects	No shielding	Use chain shielding.
Excessive side skid wear	Running with skids continuously on ground	Use check chains and tail wheels. Set skids above ground.

\* Check belt for damage by laying it flat on floor. If belt does not lie flat (has humps or twists) this indicates broken or stretched cords. Replace belt.

# ASSEMBLY

## DEALER SET-UP INSTRUCTIONS

These instructions are for the assembly of the MD80 and D80. Many of the procedures apply to both units. When an instruction applies to a specific unit, the section heading will indicate which unit.

Assembly of this cutter is the responsibility of the WOODS dealer. It should be delivered to the owner completely assembled, lubricated and adjusted for normal cutting conditions.

Complete check lists when assembly is complete.

The cutter is shipped partially assembled. Assembly will be easier if components are aligned and loosely assembled before tightening hardware. Recommended torque values for hardware are located on page 57.

Select a suitable working area. Open parts boxes and lay out parts and hardware to make location easy. Refer to illustrations, accompanying text, parts lists and exploded view drawings.

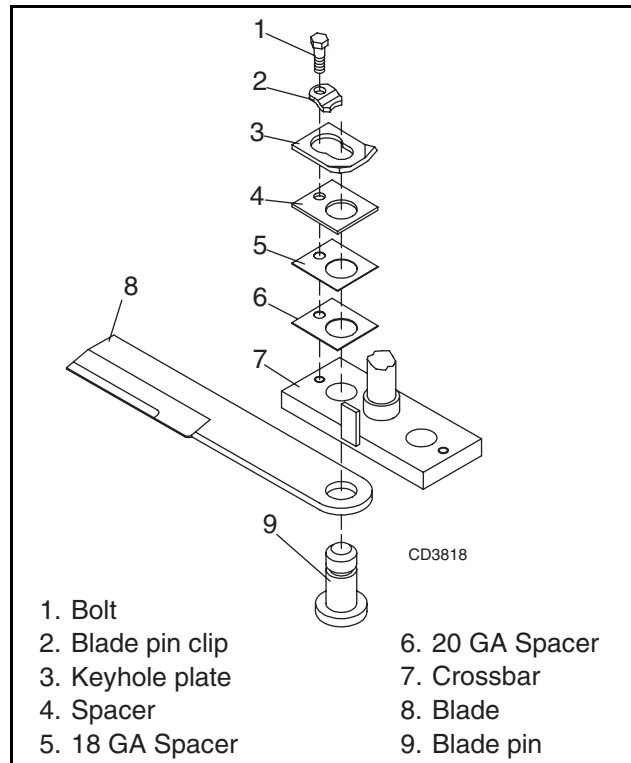
### **WARNING**

■ **Make sure spring-activated locking pin or collar slides freely and is seated firmly in tractor PTO spline groove.**

### **CAUTION**

■ **Always wear relatively tight and belted clothing to avoid getting caught in moving parts. Wear sturdy, rough-soled work shoes and protective equipment for eyes, hair, hands, hearing, and head; and respirator or filter mask where appropriate.**

## Blade Installation



**Figure 20.** Blade Installation

Either place cutter on stands or hang to permit access to both top and bottom. Make sure cutter is secured to prevent it from falling.

Liberalily coat blade pin and crossbar hole with Never-Seez® or equivalent. Make sure blade is offset away from deck and cutting edge is positioned for counter-clockwise rotation as viewed from top of deck.

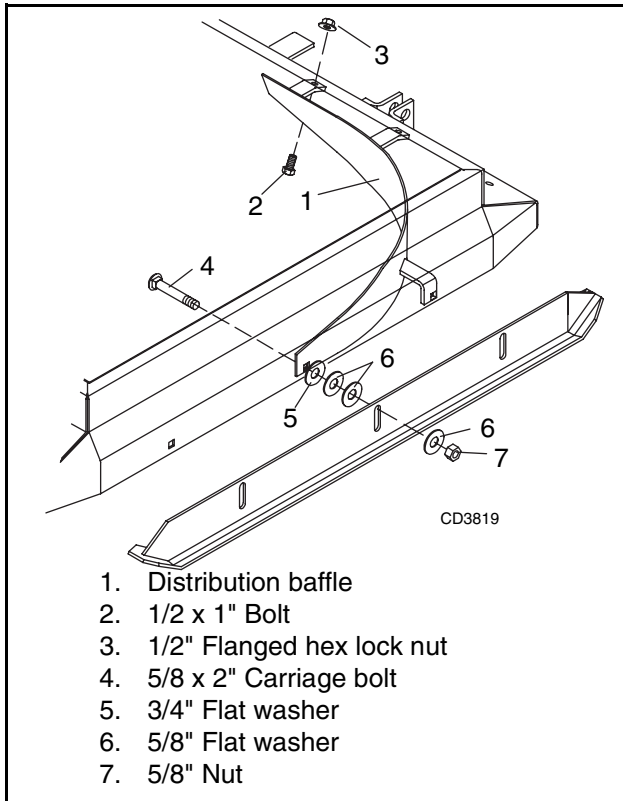
Install blade pin (9) up through blade (8) then through hole in crossbar and push firmly against crossbar (7). Install as many spacers (4, 5 or 6) as possible and still be able to slide keyhole plate (3), with ears up as shown, into blade pin groove. Place blade pin clip (2) over keyhole plate and into blade pin groove. Secure with bolt (1). Repeat for opposite blade.

Blade should be snug but swivel on pin without excessive force. Retain any spacers not used in installation for use when blade wears or on future installations.

## Distribution Baffle Installation

A distribution baffle is supplied. It is recommended when mowing grass and weeds. It should not be used when operating cutter in heavy brush.

Remove the two rear carriage bolts from the left side skid. Place baffle (1) under cutter frame and attach as shown in Figure 21.



1. Distribution baffle
2. 1/2 x 1" Bolt
3. 1/2" Flanged hex lock nut
4. 5/8 x 2" Carriage bolt
5. 3/4" Flat washer
6. 5/8" Flat washer
7. 5/8" Nut

Figure 21. Distribution Baffle Installation

## Gearbox Lubrication

### NOTICE

■ The gearbox was not filled at the factory. It must be serviced before operating cutter. Failure to service will result in damage to the gearbox.

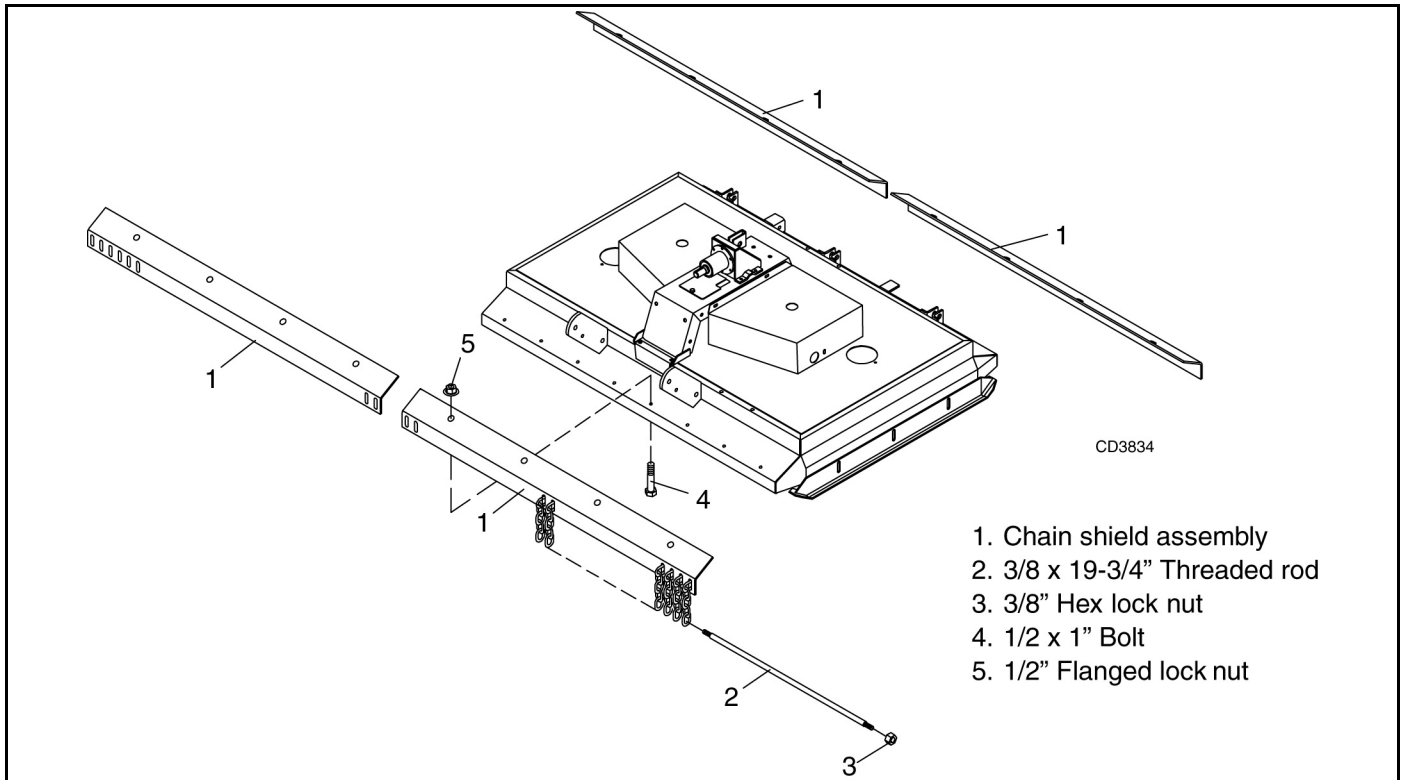
## Chain Shielding Installation

### ⚠ DANGER

■ Full chain shielding, designed to reduce the possibility of thrown objects, must be installed when operating in populated areas or other areas where thrown objects could injure people or damage property. If this machine is not equipped with full chain shielding, operation must be stopped when anyone comes within 300 feet.

All four chain assemblies (1) are interchangeable. Place each assembly on the cutter and attach by inserting bolt (4) up through the cutter and chain shield assembly, then install flange lock nut (5) on each bolt.

The threaded rods (2) are sold separately. To install, place a lock nut (3) on one end and thread rod (2) through bottom of 16 chain links, then secure with another lock nut (3). Two rods (2) are used on each chain shield assembly (1).



1. Chain shield assembly
2. 3/8 x 19-3/4" Threaded rod
3. 3/8" Hex lock nut
4. 1/2 x 1" Bolt
5. 1/2" Flanged lock nut

Figure 22. Chain Shielding Assembly

## Wheel Yoke Installation for D80-2 Pull-Type Cutter

The wheel yoke for use with pneumatic tires is illustrated. The spring-loaded wheel yoke installs the same.

Attach wheel yoke (6) to rear of cutter frame with clevis pins (15) and cotter pins (3) at two points.

Insert crank (11) through pivot block (10). Slide sleeve (7) onto crank, align hole in sleeve and hole in crank, and drive the spirol pin (8) into the assembly to attach.

Thread pivot nut (2) onto crank (11) until it will install into pivot lug (1), then attach with cotter pin (3). Install

spirol pin (4) into crank (11) to prevent crank detachment.

Attach axle with rim (12) and tire (not supplied) to wheel yoke using lock washer (13) and nut (14).

### NOTICE

■ You must use the pneumatic tire with this wheel yoke. The solid tire may be used with the spring-loaded wheel yoke.

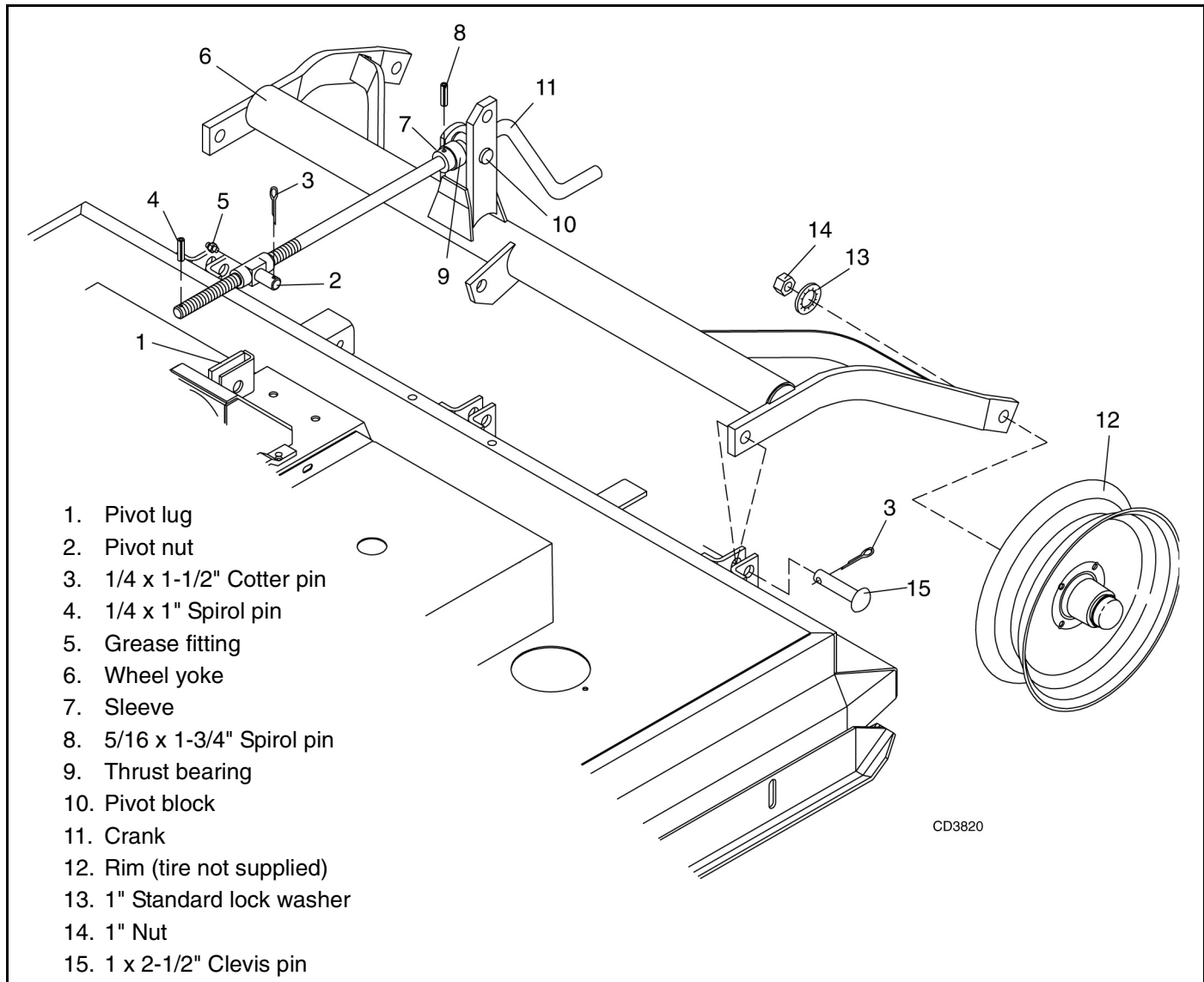
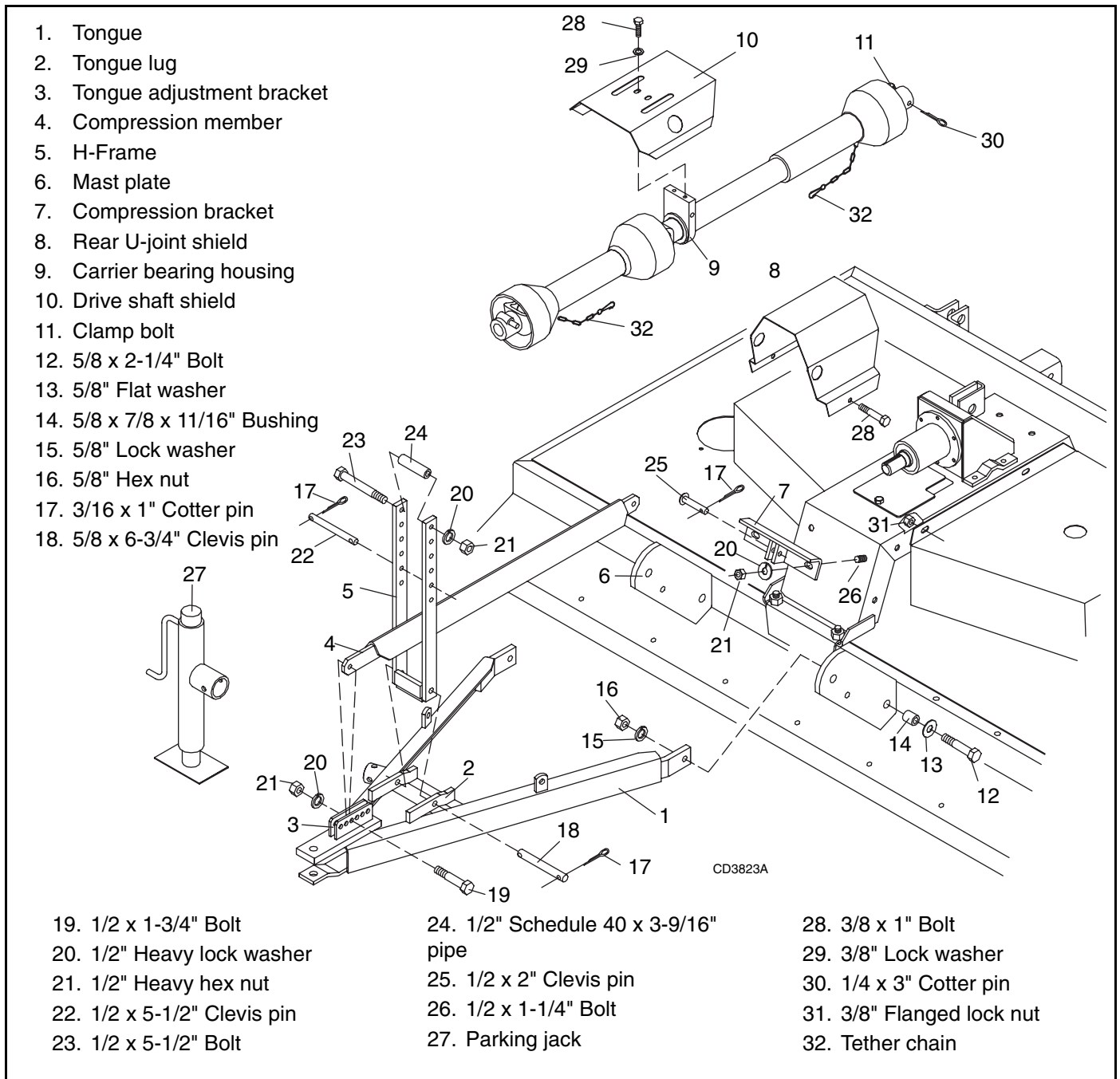


Figure 23. Wheel Yoke Installation



**Figure 24.** Tongue and H-Frame Assembly

### Tongue Installation for D80-2 Pull-Type Cutter

Attach compression bracket (7) to front of gearbox stand with lock washers (20) and nuts (21), see Figure 24.

Align holes in tongue (1) to bottom hole of mast plate (6) and insert bushing (14) through the holes, then place washer (13) on bolt (12) and insert through mast plate, bushing and tongue. Install lock washer (15) over bolt and attach with nut (16).

Support tongue by attaching jack (27).

Attach compression member (4) to compression bracket (7) with clevis pin (25) and cotter pin (17), then attach front end to tongue with bolt (19), lock washer (20) and nut (21). The compression member setting must be adjusted when the cutting height is set.

Align H-frame (5) to tongue (1) and attach with clevis pin (18) and two cotter pins (17).

Place key in gearbox input shaft, loosen clamp bolt (11) on rear of driveline, and slide driveline onto gearbox input shaft. Tighten clamp bolt and install cotter pin (30) through driveline and input shaft. Snap rear tether

chain (32) around the compression link to prevent driveline shield rotation.

Align driveline in H-frame and insert clevis pin (22) through H-frame and carrier bearing (9). Attach by inserting two cotter pins (17) in clevis pin (22). Snap middle tether chain (32) around H-frame to prevent driveline shield rotation.

Attach rear universal joint shield (8) to gear stand as shown with bolts (28) and nuts (31). Place forward driveline shield (10) over H-frame and attach with lock washer (29) and bolt (28).

Attach pipe (24) to H-frame using bolt (23), lock washer (20) and nut (21). Attach front tether chain (32) securely to tractor.

### Optional Hydraulic Installation for D80-2 Pull-Type Cutter

Remove the crank (7) from pivot link holder (6), insert pivot link (5) into pivot link holder (6), then install the crank and cotter pin (8), see Figure 25.

Remove bolt (2) from H-frame, install hydraulic hose holder (3), and install bolt.

Install hydraulic cylinder (9) using clevis pins (11), then route hose through hose holder (3).

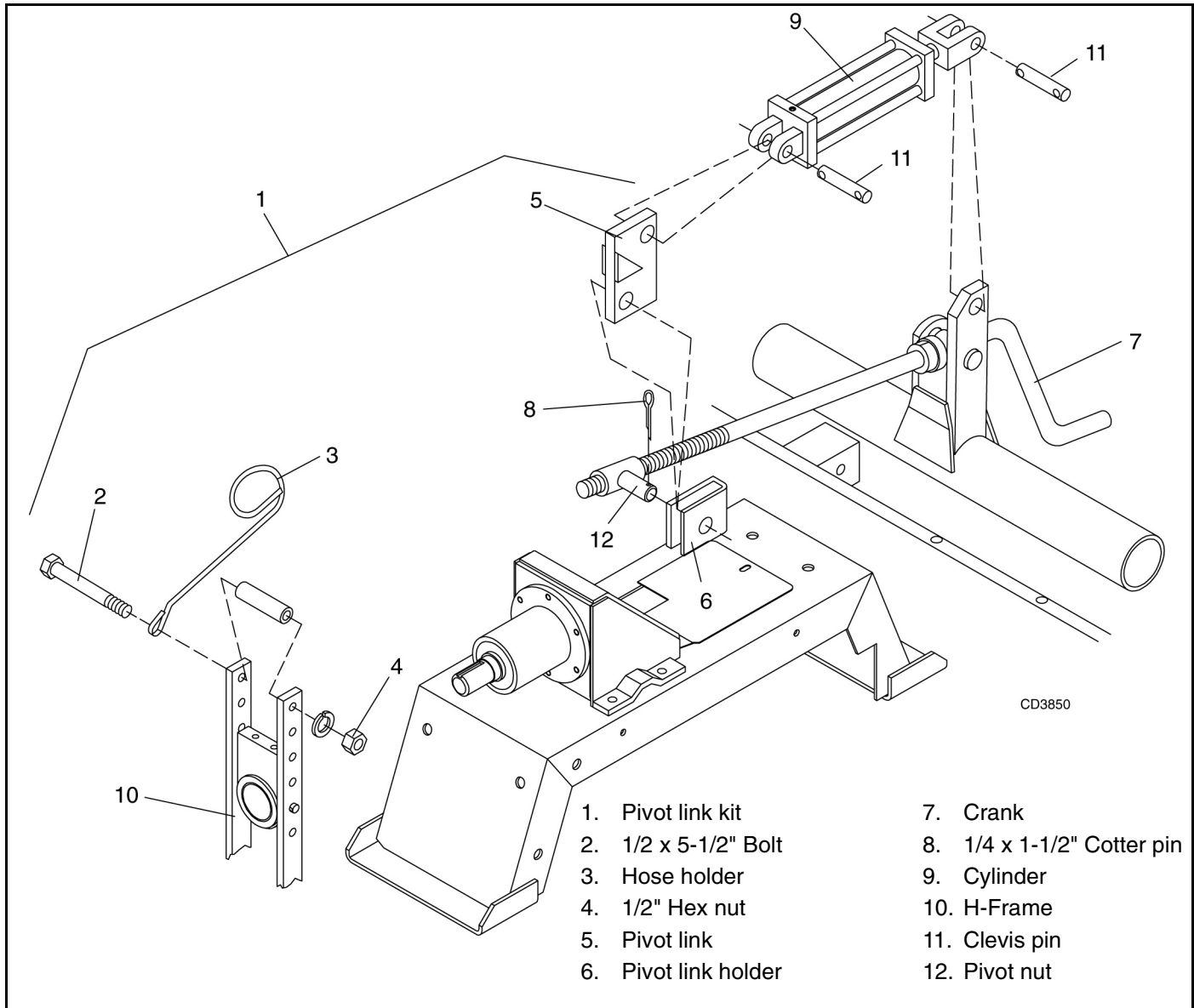
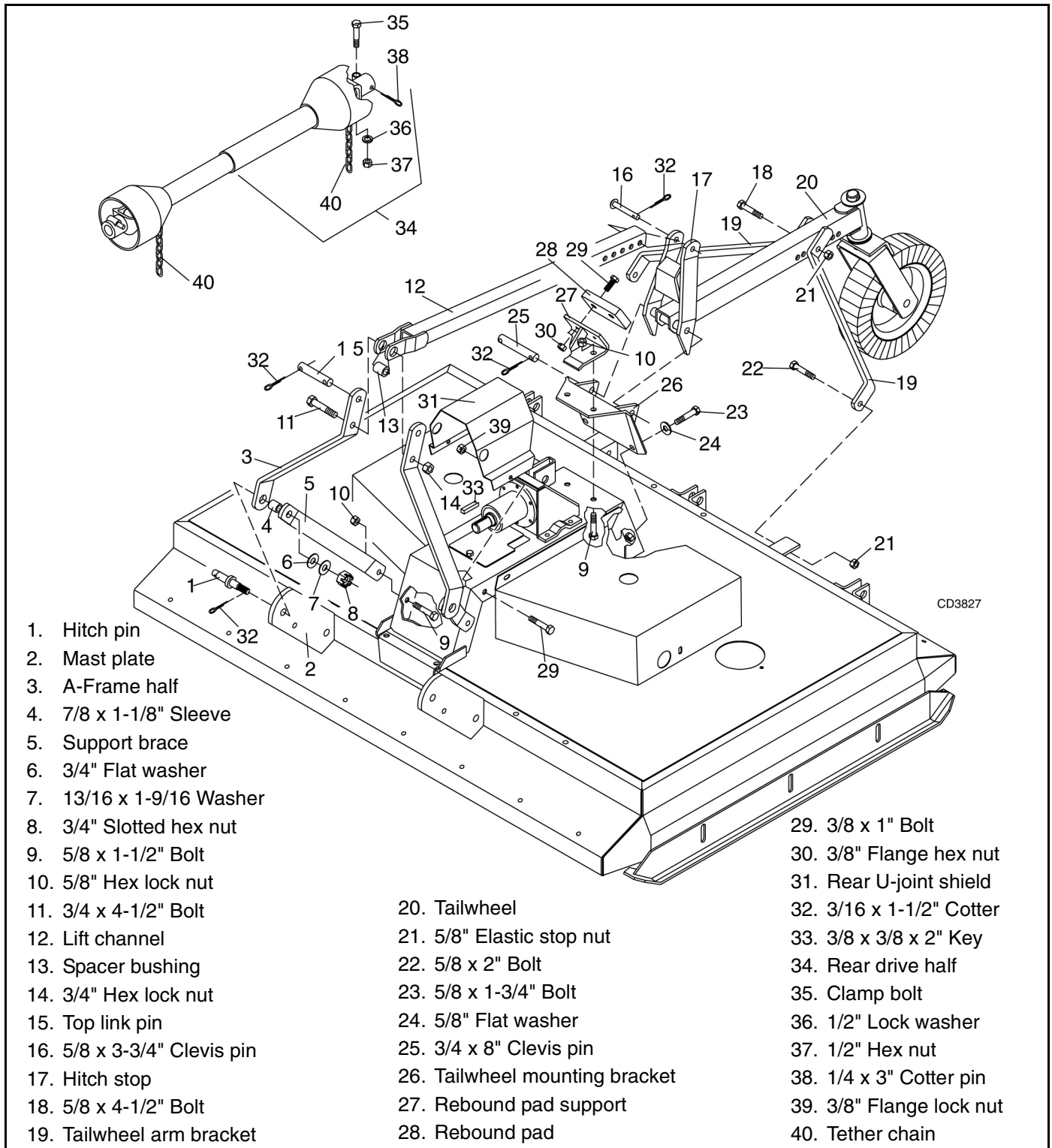


Figure 25. Optional Hydraulic Lift Assembly





**Figure 26.** Assembly of MD80 (Mounted Model)

## MD80 Assembly

### Driveline Installation

Loosen clamp bolt (35) on rear half of drive, see Figure 26. Install key (33) in gearbox keyway and slide drive onto gearbox input shaft. Install cotter key (38) and

tighten clamp bolt. Snap tether chain (40) to gear stand to prevent driveline shield rotation.

### A-Frame Lift Installation & Tailwheel Installation

Place washers (24) on bolts (23), insert through tailwheel mounting bracket (26), and tighten bolts into nuts welded to gearstand.

Bolt rebound pad (28) to rebound pad support (27). Insert bolt (9) through gearstand and bracket (26), then place rebound pad assembly on top and secure with lock nuts (10).

Attach tailwheel arm brackets (19) to brackets on rear of cutter frame with bolts (22) and elastic stop nuts (21).

Attach tailwheel assembly (20) and hitch stop (17) to tailwheel mounting bracket (26) with clevis pin (25) and secure with two cotter pins (32). Attach tailwheel arm brackets (19) to tailwheel assembly (20) with bolt (18) and elastic stop nuts (21).

Attach one end of each support brace (5) to the gearstand with bolts (9) and lock nuts (10). Insert hitch pins (1) through mast plates (2). Place A-frame arms (3) over hitch pins, then install sleeve (4) and brace (5) over pin and secure with slotted hex nut (8).

Place spacer (13) between brackets on lift channel (12) and mount between lower hole of A-frame halves with bolt (11) and lock nut (14). Attach lift channel to hitch stop (17) with clevis pin (16) and cotter pin (32).

Attach rear universal joint shield (31) to gearstand with bolts (29) and nuts (39).

## **OPTIONAL LEAF MULCHER INSTALLATION**

Loosely assemble the leaf mulcher to the cutter before tightening any hardware.

The mulcher uses the chain shielding attachment holes. It is your option to remove or leave the chain shielding in place.

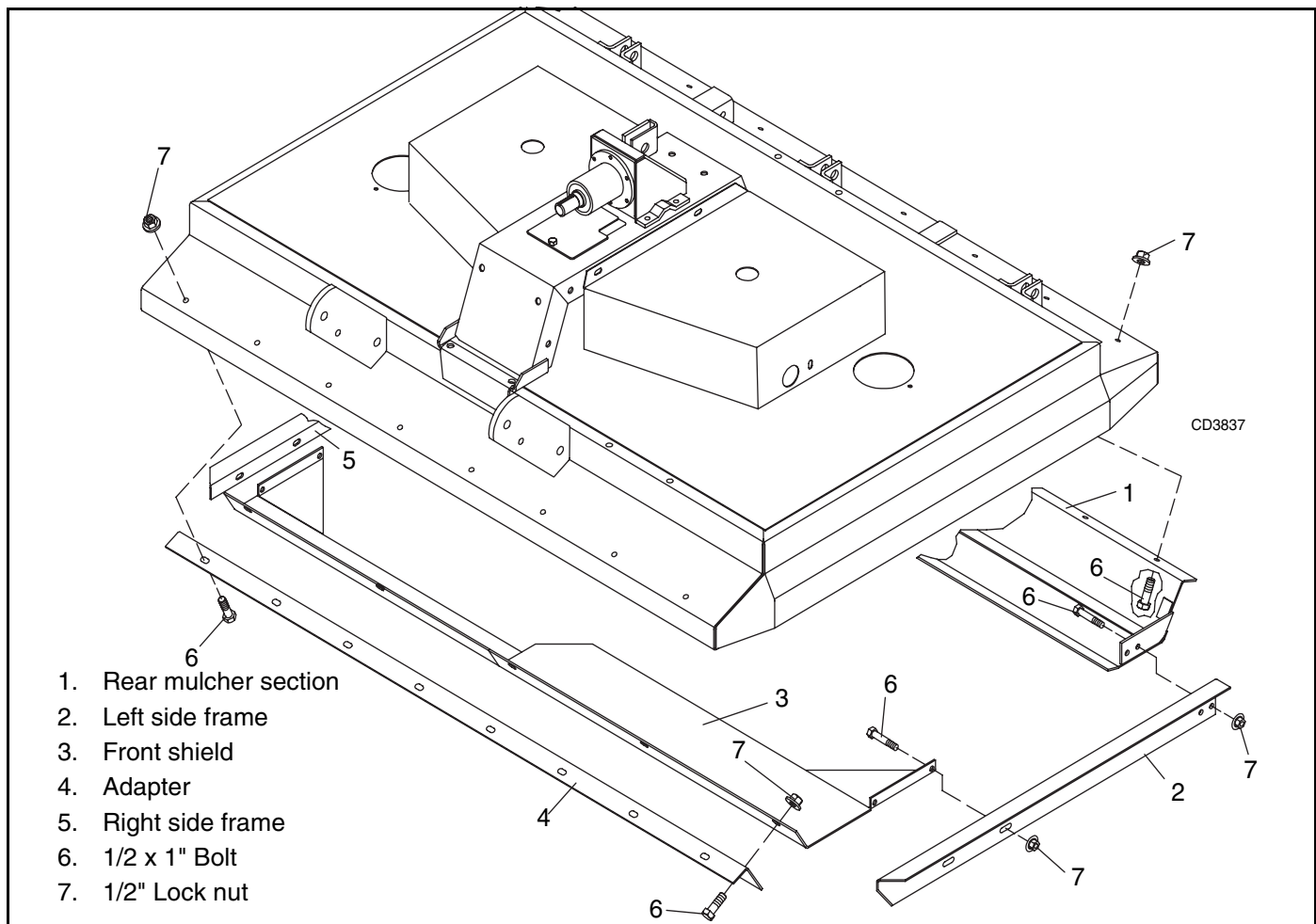
Place adapter (4) underneath the front edge of cutter and attach with bolts (6) and flange lock nuts (7).

Bolt front shield (3) to adapter using bolts (6) and flange lock nuts (7).

Place rear mulcher section (1) underneath the rear edge of cutter and attach with bolts (6) and flange lock nuts (7).

Attach right and left side frames (2 & 5) to the front and rear mulcher sections with bolts (6) and flange lock nuts (7). The slots are to the front and the U-section points outward as shown in Figure 27.

When all hardware is installed, you may tighten it.



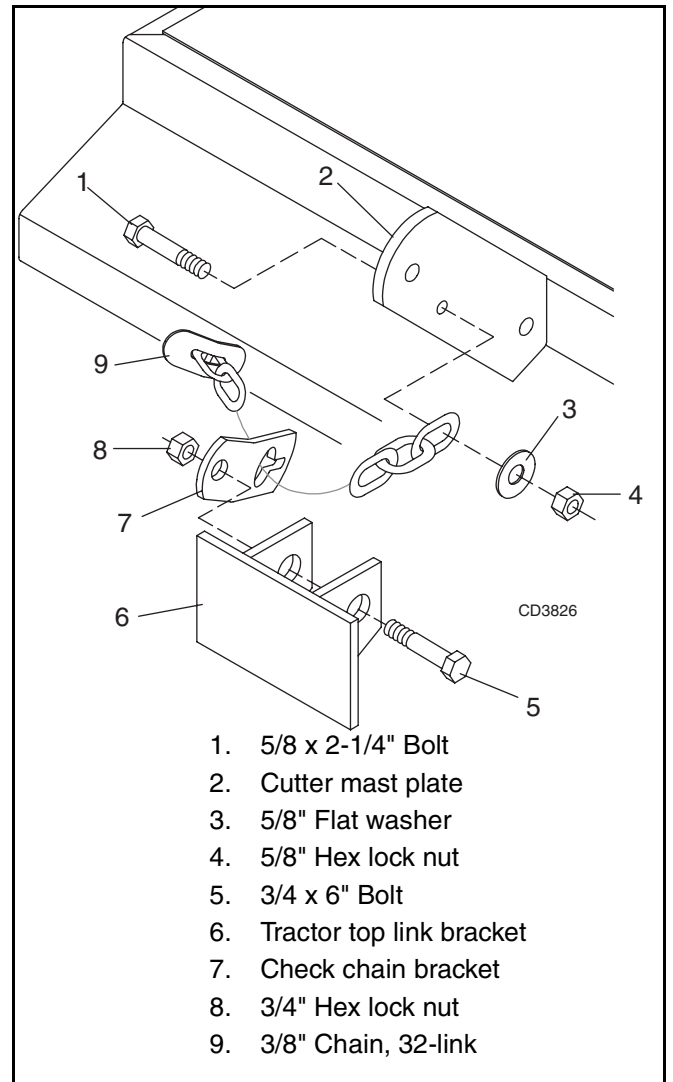
**Figure 27. Optional Leaf Mulcher Installation**

## **OPTIONAL CHECK CHAIN INSTALLATION**

Attach chain (9) to cutter mast plate (2) with bolt (1), washer (3) and nut (4) as shown. Repeat for opposite mast plate.

Attach one check chain bracket (7) to each side of the tractor top link bracket (6) with bolt (5) and nut (8) as shown.

The check chains may be adjusted to set the front cutting height of the cutter.



**Figure 28.** Optional Check Chain Installation

# DEALER CHECK LISTS

## PRE-DELIVERY CHECK LIST

### (DEALER'S RESPONSIBILITY)

Inspect cutter thoroughly after assembly to be certain it is set up properly before delivering it to customer. The following check list is a reminder of points to inspect. Check off each item as it is found satisfactory, corrections made or services performed.

- \_\_\_ Check all bolts to be sure they are tight.
- \_\_\_ Check that all cotter pins are properly installed and secured.
- \_\_\_ On pull-type cutter, make sure pin to prevent crank detachment is installed.
- \_\_\_ Check that PTO shaft is properly installed.

### **NOTICE**

■ **Gearbox was not filled at factory. It must be serviced before operating cutter. (See page 18.) Failure to service will result in damage to gearbox.**

- \_\_\_ Check that gearbox is properly serviced and seals are not leaking.
- \_\_\_ Lubricate cutter.
- \_\_\_ Check that blades have been properly installed.

## DELIVERY CHECK LIST

### (DEALER'S RESPONSIBILITY)

- \_\_\_ Show customer how to make adjustments.
- \_\_\_ Explain importance of lubrication to customer and point out lubrication points on cutter.
- \_\_\_ Point out safety features and options.
- \_\_\_ For mounted units, add wheel weights, ballast in front tires, and/or front tractor weight to enhance front end stability. A minimum 20% of tractor and equipment gross weight must be on front tractor wheels. When adding weight to attain 20% of tractor and equipment weight on front tractor wheels, you must not exceed the ROPS weight certification. Weigh the tractor and equipment. Do not estimate!
- \_\_\_ Give Operator's Manual to customer and recommend that customer become familiar with all sections, especially the safety information.
- \_\_\_ Explain to customer that when transporting cutter on road or highway, day or night, safety devices should be used to provide adequate warning to operators of other vehicles.

# INDEX TO PARTS LIST

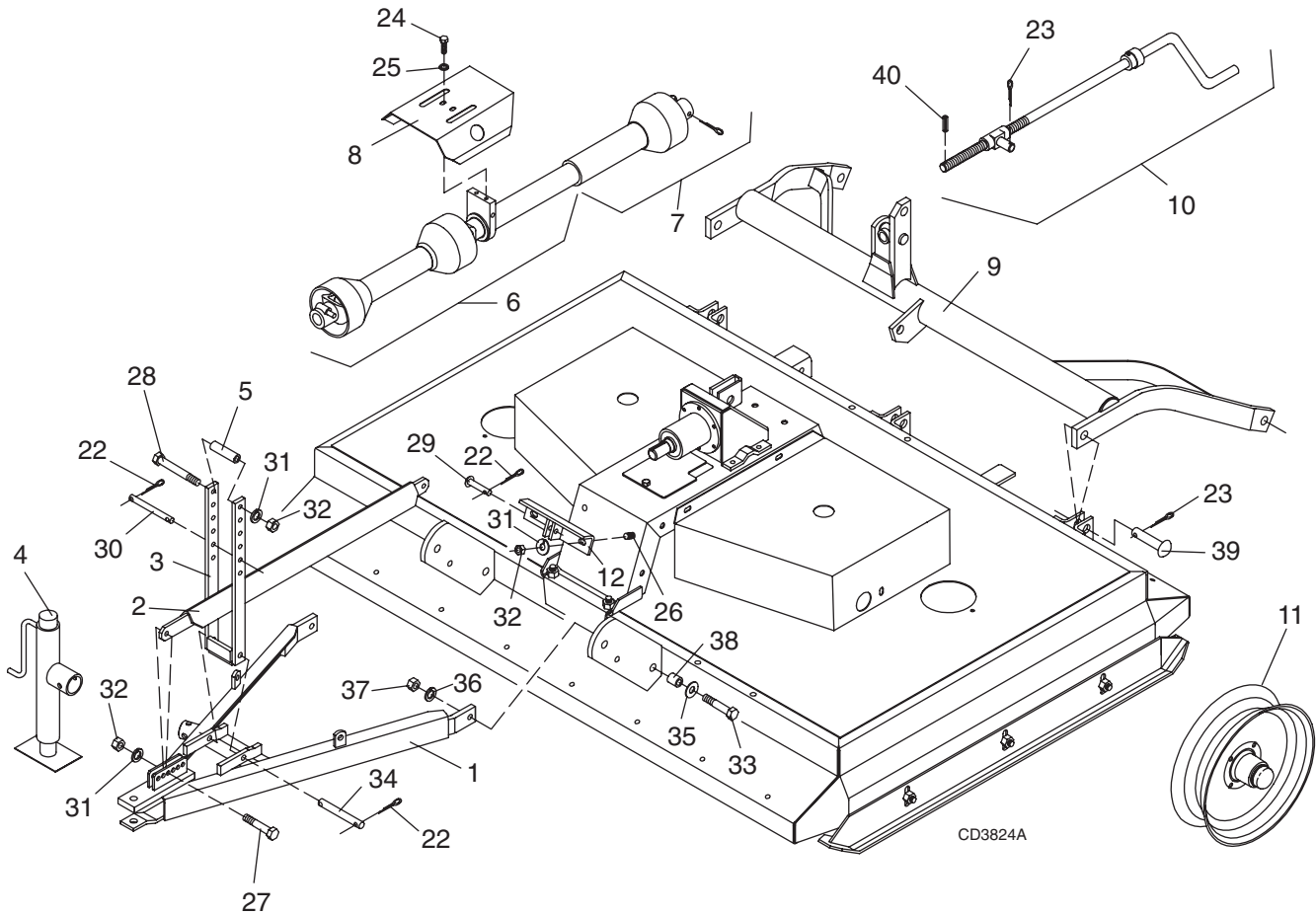
## **D80-2 (Pull-Type)**

Main Frame Assembly (Pull-Type) . . . . .	page 38
Main Frame Assembly - Common Parts . . . . .	page 40
Front 2/3 of 3-Joint Drive (Square Shaft) . . . . .	page 42
Front 2/3 of 3-Joint Drive (two lobe Shaft) . . . . .	page 43
Rear Section of Universal Drive . . . . .	page 44
Gearbox Assembly . . . . .	page 45
Blade Spindle Assembly . . . . .	page 46
Blades . . . . .	page 46
Chain Shielding Assembly . . . . .	page 47
Idler Pulley Assembly . . . . .	page 48
Parking Jack . . . . .	page 48
Height Adjustment Crank . . . . .	page 49
Spring-Loaded Wheel Yoke . . . . .	page 49
Laminated Tire with Hub & Axle . . . . .	page 50
Rim & Axle Assembly . . . . .	page 50
Aircraft Tire & Hub . . . . .	page 47
Pivot Link Kit (Optional) . . . . .	page 53
Hydraulic Hose Kit & Fittings (Optional) . . . . .	page 53
3-1/2 x 8" Hydraulic Cylinder #10475 (Optional) . . . . .	page 54
Leaf Mulcher Assembly (Optional) . . . . .	page 55

## **MD80-2 (Mounted)**

Main Frame Assembly (Mounted Model) . . . . .	page 39
Main Frame Assembly - Common Parts . . . . .	page 41
Front 1/2 of Universal Drive . . . . .	page 44
Rear Section of Universal Drive . . . . .	page 44
Gearbox Assembly . . . . .	page 45
Blade Spindle Assembly . . . . .	page 46
Blades . . . . .	page 46
Chain Shielding Assembly . . . . .	page 47
Idler Pulley Assembly . . . . .	page 48
Tailwheel Assembly . . . . .	page 52
Leaf Mulcher Assembly (Optional) . . . . .	page 55
Check Chain Assembly (Optional) . . . . .	page 55
Category 2 Hitch Pin Options . . . . .	page 56
Category 2 Bushing Kit . . . . .	page 56

## D80-2 MAIN FRAME ASSEMBLY (PULL-TYPE)

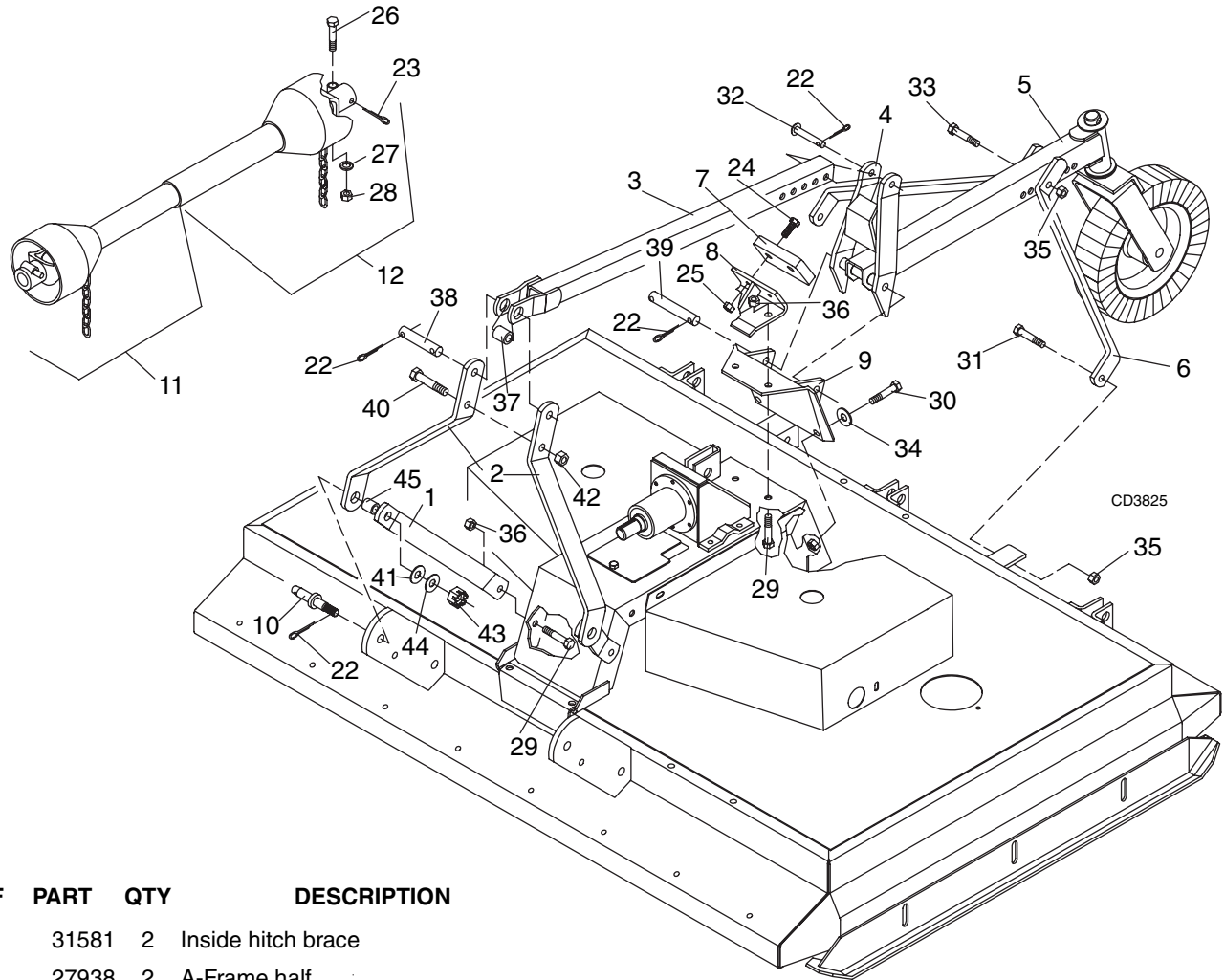


REF	PART	QTY	DESCRIPTION	REF	PART	QTY	DESCRIPTION
1	7023	1	Tongue	25	838	*	3/8 Standard lock washer
2	406	1	Compression member	26	6100	*	1/2 NC x 1-1/4 HHCS GR5
3	7030	1	H-Frame	27	24576		1/2 NC x 1-3/4 HHCS GR5
4	----	1	Parking jack	28	12305	*	1/2 NC x 5-1/2 HHCS GR5
5	7035	1	1/2 Schedule 40 x 3-9/16 pipe	29	409		1/2 x 2 Clevis pin
6	----	1	Front 2/3 of 3-joint drive	30	404		1/2 x 5-3/4 Clevis pin HT
7	----	1	Rear section of universal drive	31	855	*	1/2 Extra-heavy lock washer
8	19012	1	Drive shaft shield	32	1093		1/2 NC Heavy hex nut
9	7388	1	Wheel yoke	33	12274	*	5/8 NC x 2-1/4 HHCS GR5
10	----	1	Manual height adjustment crank	34	405		5/8 x 6-3/4 Clevis pin
11	----	2	15" Wheel	35	692	*	5/8 Standard flat washer
12	7033	1	Compression member bracket	36	1286	*	5/8 Heavy lock washer
			<b>HARDWARE</b>	37	230	*	5/8 NC Hex nut
22	1256	*	3/16 x 1 Cotter pin	38	11081		5/8 x 7/8 x 11/16 Bushing HT
23	1285	*	1/4 x 1-1/2 Cotter pin	39	445		1 x 2-1/2 Clevis pin
24	839	*	3/8 NC x 1 HHCS GR5	40	15134		1/4 x 1 Spirol pin
							* Obtain Locally - Standard Hardware

# 38 Parts

15914 (Rev. 3/23/2007)

## MD80-2 MAIN FRAME ASSEMBLY (MOUNTED MODEL)



REF	PART	QTY	DESCRIPTION
-----	------	-----	-------------

1	31581	2	Inside hitch brace
2	27938	2	A-Frame half
3	28236	1	Lift arm channel assembly
4	29071	1	Hitch stop assembly
5	-----	1	Tailwheel
6	29080	2	Tailwheel adjustment bracket
7	29070	1	Rebound bumper pad
8	28241	1	Rebound bumper support
9	28238	1	Tailwheel attachment plate
10	7049	2	Cat. 1 mounting, 5-3/4L
11	-----	1	Front 1/2 universal drive
12	-----	1	Rear section universal drive

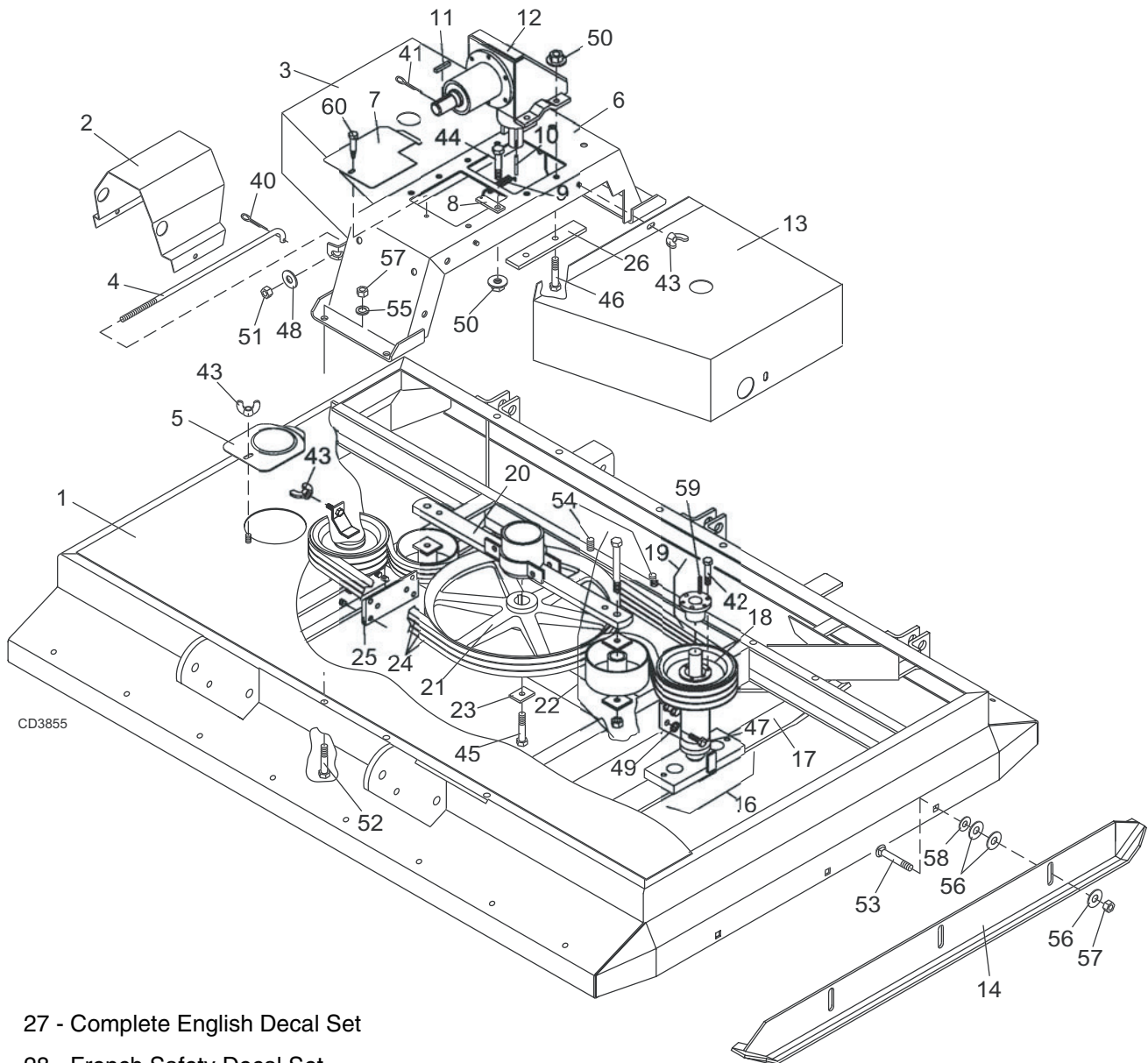
**HARDWARE**

22	1266	*	3/16 x 1-1/2 Cotter pin
23	1426	*	1/4 x 3 Cotter pin
24	839	*	3/8 NC x 1 HHCS GR5
25	14350		3/8 NC Flanged hex lock nut
26	1637	*	1/2 NC x 3-1/2 HHCS GR5
27	855	*	1/2 Extra-heavy lock washer
28	1093	*	1/2 NC Heavy hex nut
29	7832	*	5/8 NC x 1-1/2 HHCS GR5

REF	PART	QTY	DESCRIPTION
-----	------	-----	-------------

30	4548	*	5/8 NC x 1-3/4 HHCS GR5
31	902		5/8 NC x 2 HHCS GR5
32	8099		5/8 x 3-3/4 Clevis pin HT
33	3097		5/8 NC x 4-1/2 HHCS HT
34	692	*	5/8 Standard flat washer
35	12006		5/8 NC Electric stop nut
36	6239	*	5/8 NC Heck lock nut
37	12587		3/4 x 1-1/4 x 2-1/4 Sleeve
38	1591		3/4 x 4-3/8 Clevis pin
39	29075		3/4 x 8 Clevis pin
40	12558		3/4 NC x 4-1/2 HHCS GR5
41	2864	*	3/4 SAE Flat washer
42	2371	*	3/4 NC Hexk lock nut
43	5849		3/4 NF Slotted hex nut
44	31392		13/16 x 1-9/16 x 10 GA Flat washer
45	29281		7/8 x 1-1/8 x 19/32 Sleeve HT
		*	Obtain Locally - Standard Hardware

## D80-2 & MD80-2 MAIN FRAME ASSEMBLY - COMMON PARTS



27 - Complete English Decal Set

28 - French Safety Decal Set

29 - English Safety Decal Set

**40 Parts**

15914 (Rev. 3/23/2007)

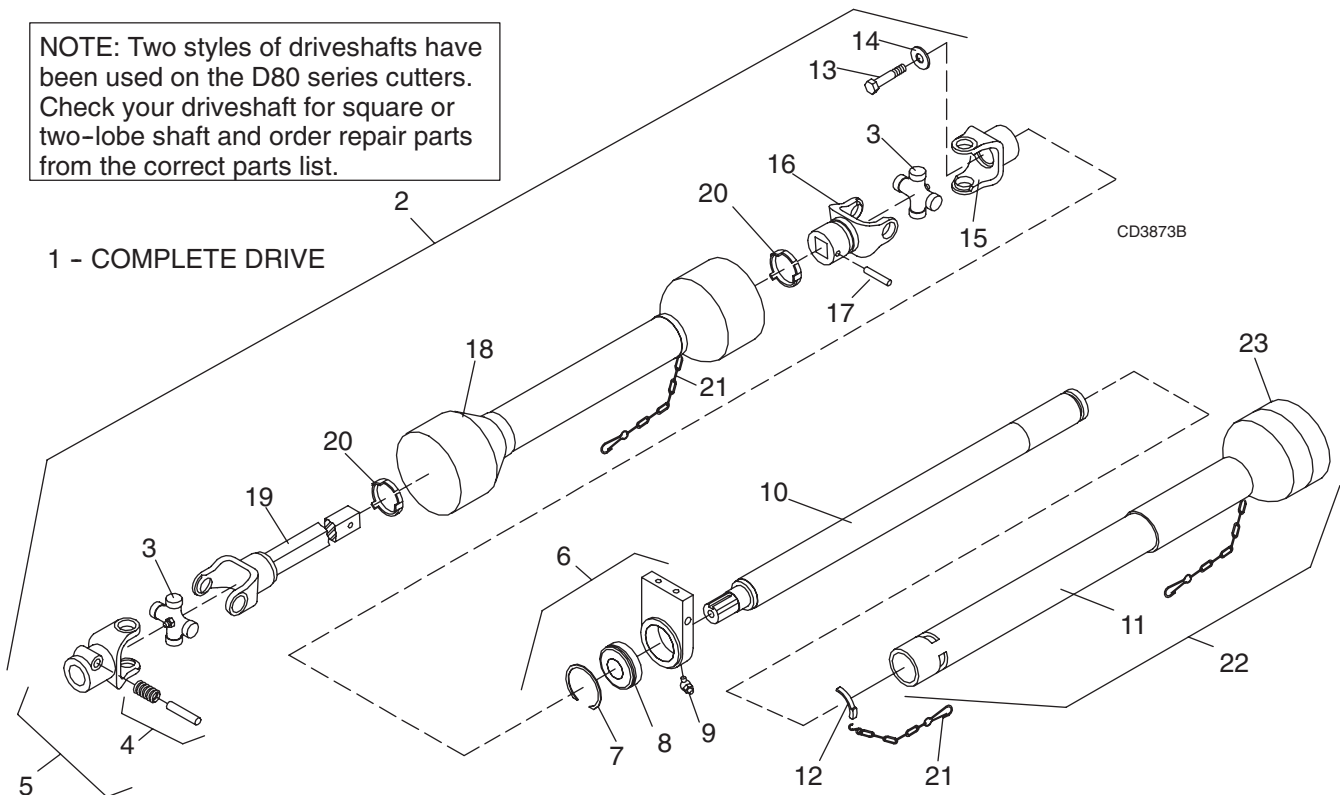


## D80-2 & MD80-2 MAIN FRAME ASSEMBLY - COMMON PARTS

REF	PART	QTY	DESCRIPTION	REF	PART	QTY	DESCRIPTION
1	----	1	Deck (not sold separately)	27	15828	1	Complete english decal set
2	28219	1	Rear drive shield	28	55827	1	French safety decal set
3	15818	1	Right v-belt shield	29	15827	1	English safety decal set
4	28230	1	Take-up rod idler				<b>HARDWARE</b>
5	3444	2	Access hole cover	40	1266*		3/16 x 1-1/2 Cotter pin
6	28225	1	Gearbox stand	41	1426*		1/4 x 3 Cotter pin
7	28203	1	Tower access cover	42	14562*		5/16 NC x 1 HHCS GR5
8	1942	1	Gearbox angle bracket	43	1287*		3/8 NC Wing nut
9	419	1	Extension spring, 4-1/8 L	44	6100*		1/2 NC x 1-1/4 HHCS GR5
10	607	1	3/8 x 3/8 x 2-3/8 Key	45	1262		1/2 NC x 1-1/4 HHCS drilled head
11	608*	1	3/8 x 3/8 x 2 Key	46	24576		1/2 NC x 1-3/4 HHCS GR5
12	----	1	Gearbox	47	3452		1/2 NF x 1-1/2 HHCS GR5
13	15819	1	Left V-belt shield	48	854*		1/2 Standard flat washer
14	15779	2	Skid shoe 56.2	49	855*		1/2 Extra-heavy lock washer
15	15817	1	Left rear baffle	50	11900*		1/2 NC Flaged hex lock nut
16	----	2	Spindle	51	6241		1/2 NC Elastic stop nut
17	----	4	Blades	52	4548*		5/8 NC x 1-3/4 HHCS GR5
18	10578	2	3TB 7.5 Sheave	53	2855*		5/8 NC x 2 Carriage bolt
19	1482	2	P1 1-1/4 Straight bore bushing	54	12274*		5/8 NC x 2-1/4 HHCS GR5
20	10617	1	Idler arm assembly	55	1286*		5/8 Heavy lock washer
21	10575	1	3 SB 18.5 Sheave	56	692*		5/8 Standard flat washer
22	----	2	Idler assembly	57	230*		5/8 NC Hex nut
23	606	1	1/4 x 1-1/2 x 2 Lug	58	2864*		3/4 SAE Flat washer
24	222	1	Set of 3 matched v-belts	59	7142		1/4 x 1/4 x 2 Key
25	29038	2	Spindle support plate	60	27610		5/16 x 3/4 Sheet metal screw
26	29280	2	3/8 x 1-1/2 x 9-1/4 support plate				* Obtain Locally - Standard Hardware

## D80-2 FRONT 2/3 OF 3-JOINT DRIVE (SQUARE SHAFT)

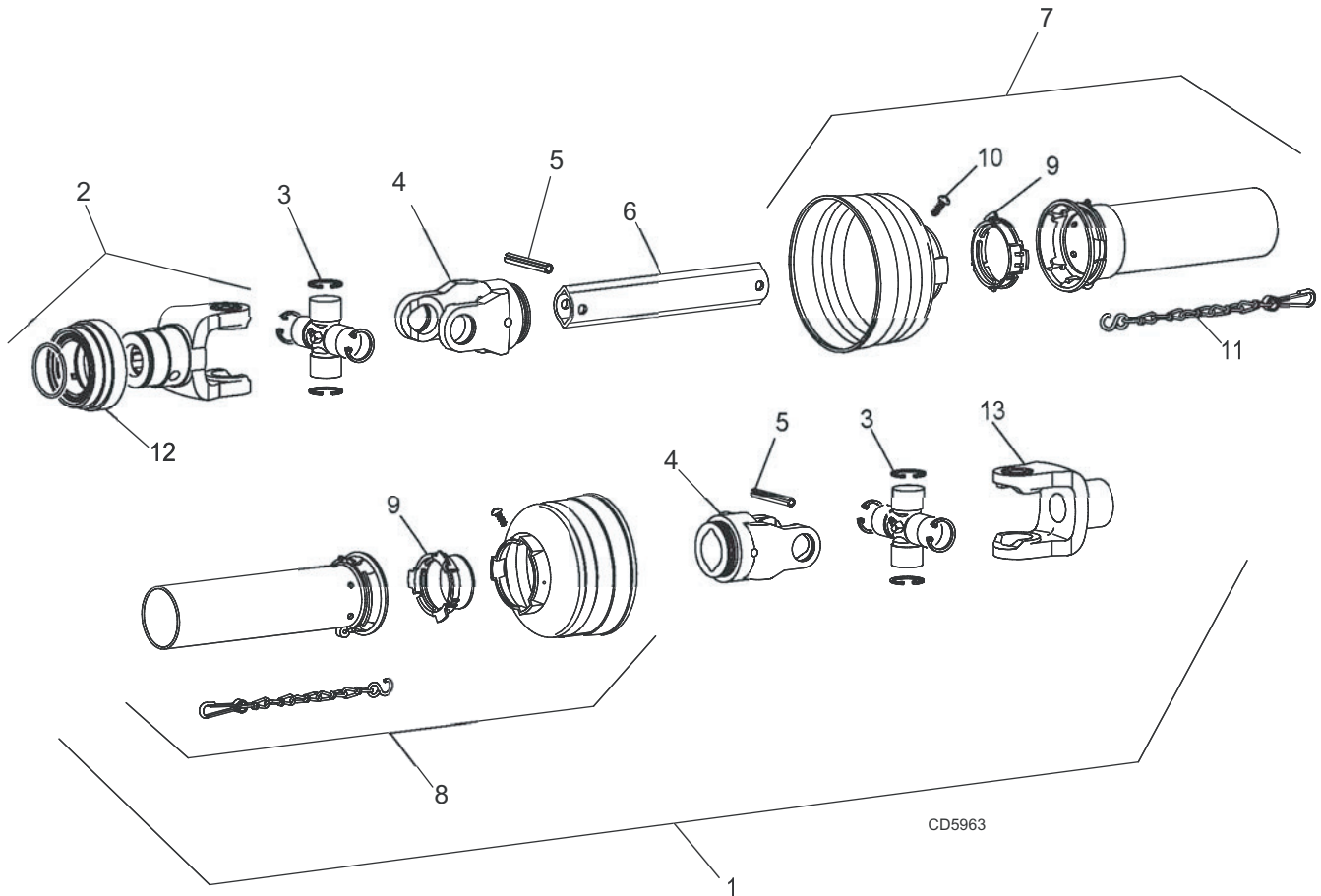
NOTE: Two styles of driveshafts have been used on the D80 series cutters. Check your driveshaft for square or two-lobe shaft and order repair parts from the correct parts list.



REF	PART	QTY	DESCRIPTION	REF	PART	QTY	DESCRIPTION
1	19054	1	Front 2/3 of 3-joint drive 35N	13	1311	1	1/2 NF x 1 HHCS, drilled head
2	44919	1	Front 2 joints shielded 35N	14	-----*	1	1/2 x 1-1/2 x 1/8 Flat washer
3	110	2	U-Joint repair kit 35N	15	105	1	1-5/16 Bore universal joint yoke 35N
4	117	1	Lock pin and spring	16	19043	1	Yoke
5	115	1	1-3/8 Quick disconnect yoke 35N	17	4674	1	3/8 x 2 Spirol pin
6	1251	1	Bearing holder with bearing (includes 7, 8 & 9)	18	19045	1	Shield, decaled 2-joint 21.94 (includes items 20 & 21)
7	12128	1	.062 x 72 mm ID Snap ring	19	4663	1	Square shaft & yoke 35N
8	3502	1	1.37 ID x 2.83 OD Ball bearing	20	15740	2	World shield bearing
9	2985*	-	1/4 - 28 Threaded 90-degree grease fitting	21	15739	3	World shield tether chain 27.5
10	19036	1	Decaled tube, sleeve & stub, 24.38	22	19609	1	Plastic shield kit (includes items 11 & 23)
11	15952	1	Plastic shield 2.75 x 17.69 (includes items 12 & 21)	23	19038	1	Shield, decaled
12	15141	4	Bearing for tubular shaft				* Obtain Locally - Standard Hardware

## D80-2 FRONT 2/3 OF 3-JOINT DRIVE (TWO-LOBE SHAFT)

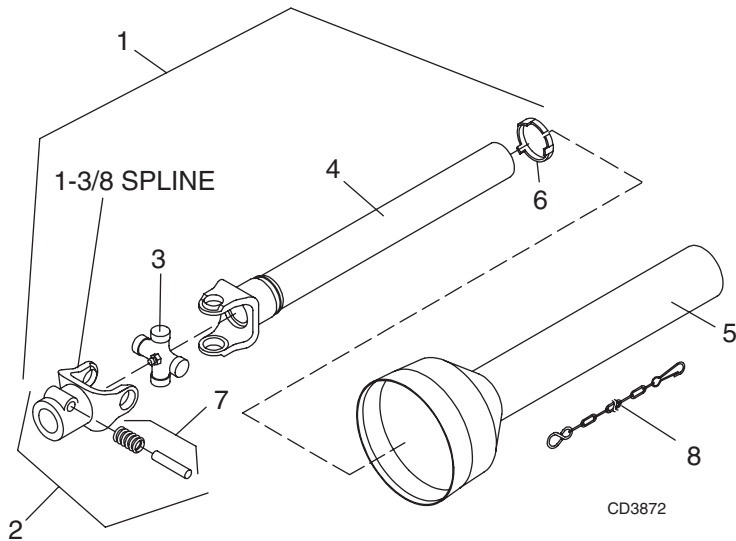
NOTE: Two styles of driveshafts have been used on the D80 series cutters. Check your driveshaft for square or two-lobe shaft and order repair parts from the correct parts list.



REF	PART	QTY	DESCRIPTION
1	44919	1	Front 2 joints shielded 1340
2	40574	1	Yoke, 1-3/8 -6SP (complete with lock collar)
3	110	2	Cross & bearing kit
4	40576	2	Inboard yoke
5	40764	2	Spring pin 10 mm x 80 mm (packet of 10)
6	40588	1	Outer profile (cut to length)

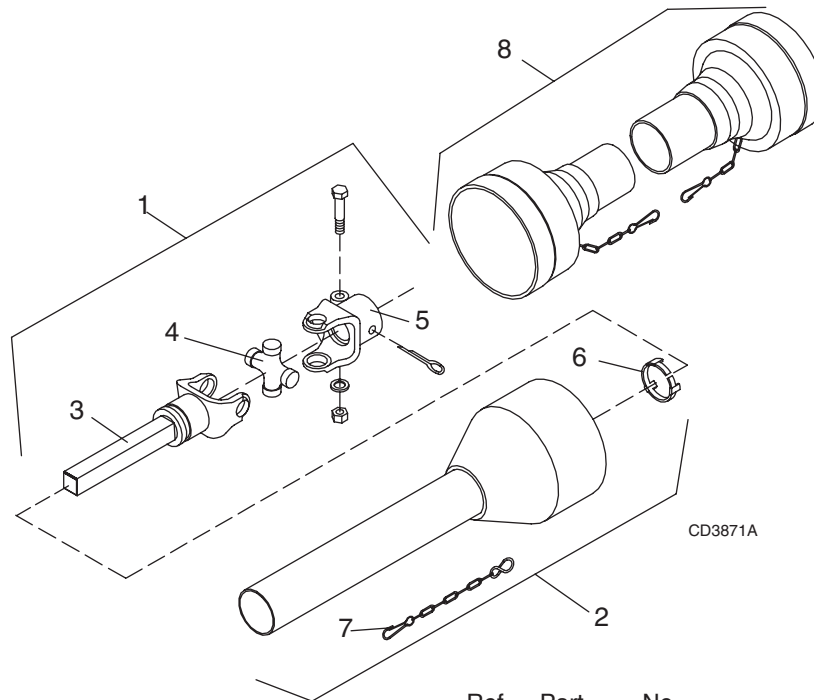
REF	PART	QTY	DESCRIPTION
7	40590	1	Guard, outer half (includes items 9, 10 & 11) (cut to length)
8	40591	1	Guard, inner half (includes items 9, 10, & 11) (cut to length)
9	40766	2	Bearing ring (package of 2)
10	40778	2	Screw (package of 10)
11	40777	2	Anti-rotation chain
12	40589	1	Lock collar repair kit (without yoke)
13	105	1	Yoke, 1.31 Bore

## MD80-2 FRONT 1/2 OF UNIVERSAL DRIVE



Ref No	Part No	No Used	Description
1	19064	1	Front half of 2-joint drive, complete
2	115	1	1-3/8, 6-Tooth spline, quick disconnect U-joint yoke
3	110	1	Universal joint repair kit 35N
4	7406	1	Yoke and tubular shaft 35N
	-or-	-or-	
4	7360	1	Yoke and tubular shaft 27.5 long
5	15907	1	Plastic shield 2.75 x 22.8 (includes 6 & 8)
	-or-	-or-	
5	15890	1	Plastic shield 2.75 x 29.0 (includes 6 & 8)
6	15740	1	World shield outer bearing
7	117	1	Lock pin and spring
8	15739	1	World shield tether chain, 27.5

## D80-2 & MD80-2 REAR SECTION OF UNIVERSAL DRIVE



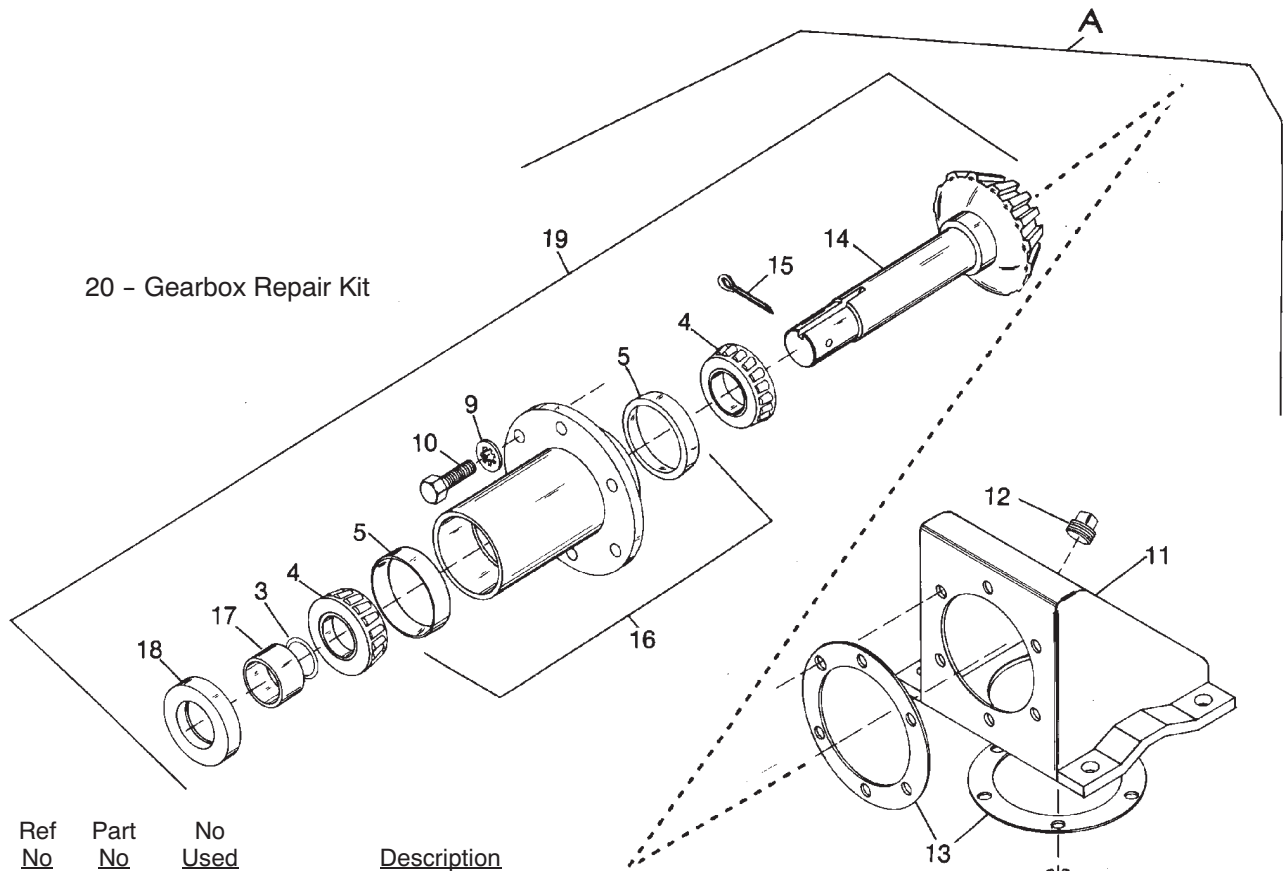
Ref No	Part No	No Used	Description
1	19039	1	Universal joint yoke & square shaft 23-7/8 L with shield
2	19038	1	Decaled shield 3 x 22 long (includes 6 & 7)
3	7368	1	Square shaft & yoke, 35N

Ref No	Part No	No Used	Description
4	110	1	Universal joint repair kit 35N
5	6216	1	Clamp yoke
6	15740	1	Shield bearing
7	15739	1	Shield tether chain 27-1/2"
8	19604	1	Shield kit (contains 15890 & 19038)

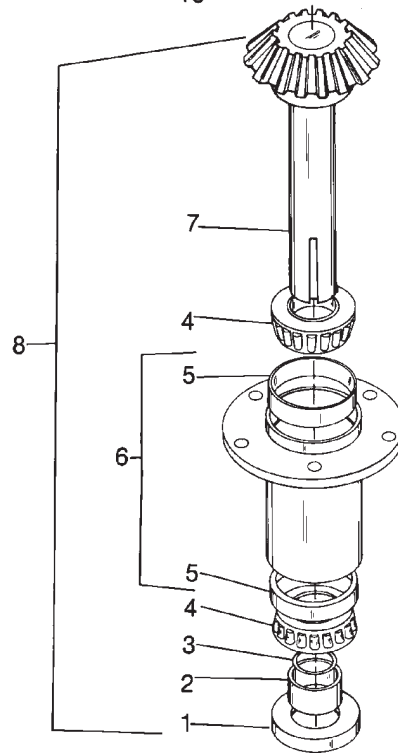
**44 Parts**

15914 (Rev. 3/23/2007)

## D80-2 & MD80-2 GEARBOX ASSEMBLY

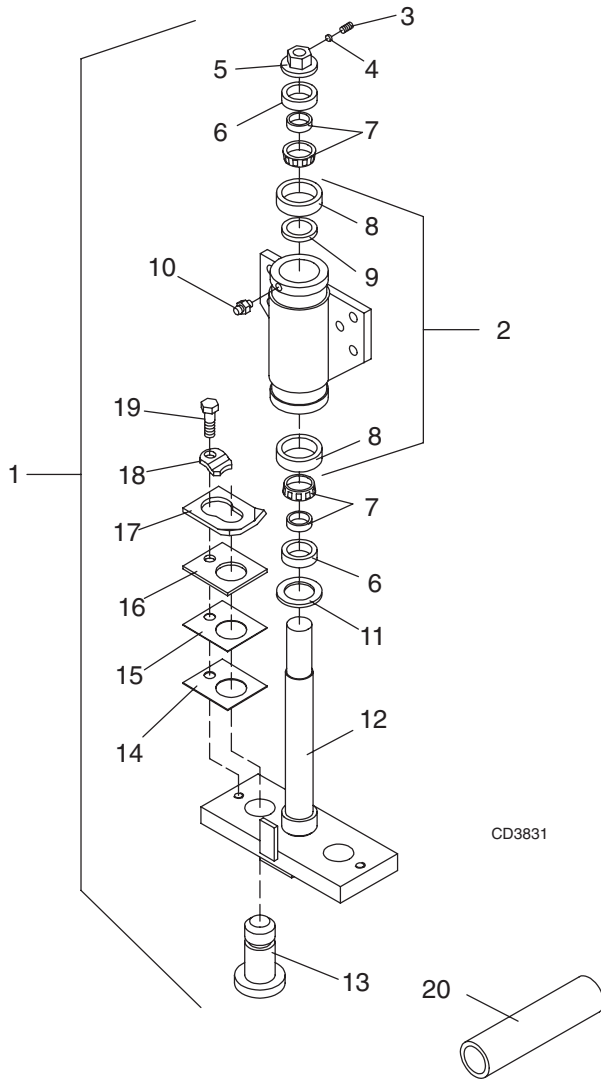


Ref No	Part No	No Used	Description
A	6222	1	1:1 Gearbox assembly complete
1	213	1	Seal for 1-3/4 shaft
2	209	1	1-1/2 x 1-3/4 x 1-3/8 Sleeve
3	255	1	Ring seal
4	211	4	Bearing cone 2788A
5	210	4	Bearing cup 2720
6	6226	1	Vertical gear shaft housing with cups
7	207	1	Vertical gear and shaft
8	202	1	Vertical gear and housing assembly (includes items 1 thru 4, 6 & 7)
9	3093 *	12	3/8 Shakeproof lockwasher
10	839 *	12	3/8 NC x 1 Hex head cap screw GR5
11	6224	1	Gearbox housing
12	1284 *	1	1" Pipe plug, recessed head
13	1998	1	Gasket set (includes installation instructions)
14	206	1	Horizontal gear and shaft
15	1426 *	1	1/4 x 3 Cotter pin
16	6225	1	Horizontal gear shaft housing with cups
17	208	1	1-1/2 x 1-3/4 x 1 Sleeve
18	212	1	Seal for 1-3/4 shaft
19	201	1	Horizontal gear and housing assembly (includes items 3, 4, 14 and 16 thru 18)
20	53411	1	Gearbox repair kit (Includes all bearings, sleeves and seals)



\* Obtain Locally

## D80-2 & MD80-2 BLADE SPINDLE ASSEMBLY

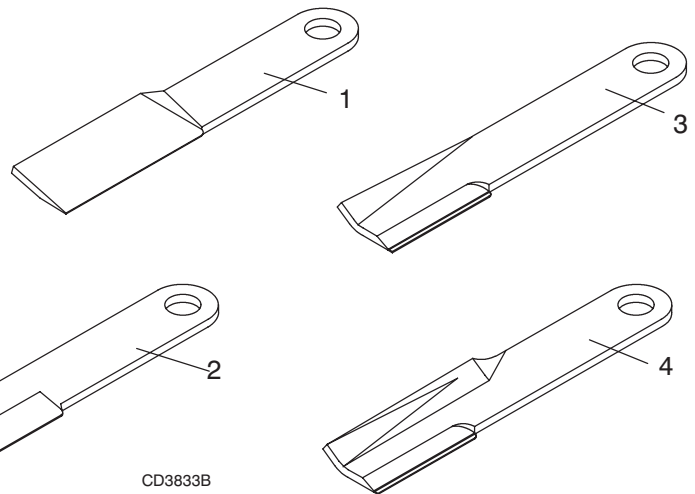


REF	PART	QTY	DESCRIPTION
1	15805	1	Spindle assembly
2	7143	1	Spindle housing with bearing cups and grease fitting
3	7269	1	3/8 NF x 3/8 Set screw
4	7127	1	5/16 x 5/32 Dowel plug
5	7115	1	1-3/8 Flanged spindle nut
6	5298	2	Seal for 1-3/4 shaft
7	7068	2	Bearing cone and sleeve
8	7069	2	Bearing cup
9	7129	1	1-3/8 x 2-1/8 x 18 GA Shim
10	195	1	Grease fitting
11	7138	1	1-3/8 x 2-3/4 x 1/4 Flat washer
12	15785	1	Crossbar
13	15803	2	1-1/2 Blade pin x 3.32 L
14	10520	2	18 GA Shim
15	13946	2	20 GA Shim
16	5523	2	Spacer
17	32603	2	Keyhole plate - special
18	32604	2	Blade lock clip - special
19	6100*	2	1/2 NC x 1-1/4 HHCS
20	7571	1	7/64 Wall x 1-5/8 x 11 Tube (Optional)

CD3831

## D80-2 & MD80-2 BLADES

REF	PART	QTY	DESCRIPTION
1	15789KT	4	General purpose CCW blade
2	15790KT	4	Flat CCW blade
3	15791KT	4	High fin CCW formed blade
4	1003413KT	4	SHL Fin CCW formed blade

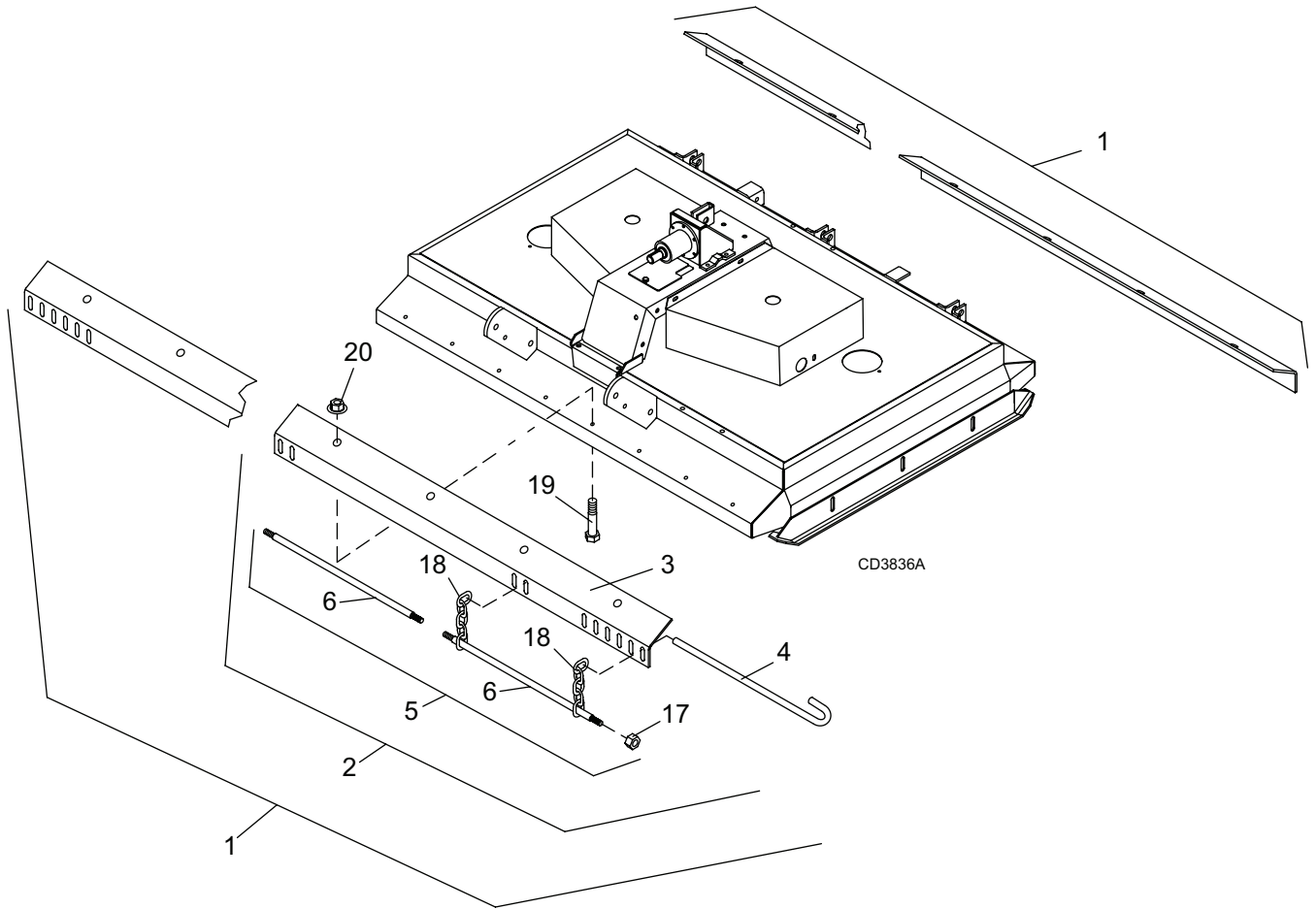


CD3833B

**46 Parts**

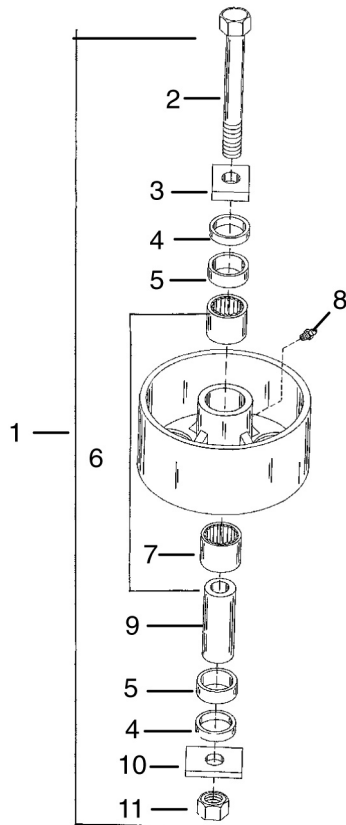
15914 (Rev. 3/23/2007)

## D80-2 & MD80-2 CHAIN SHIELDING ASSEMBLY



REF	PART	QTY	DESCRIPTION	REF	PART	QTY	DESCRIPTION
1	29085	2	Chain shielding complete (does not include items 6 & 17)	6	12136	8	3/8 & 19-3/4 Threaded rod, 16-chain
2	29086	4	Chain plate assembly (does not include items 6 & 17)	<b>HARDWARE</b>			
3	29087	4	Chain shield plate	17	6698	*	3/8 NC Hex lock nut
4	1007850	4	Pin, 31 to 33 chains	18	3994		5/16 Chain, 5-link
5	8731	2	Drag-rod kit - Optional (includes items 6 & 17)	19	25475		1/2 x 1 HHCS GR5
				20	11900	*	1/2 NC Flanged hex lock nut
						*	Obtain locally, standard hardware

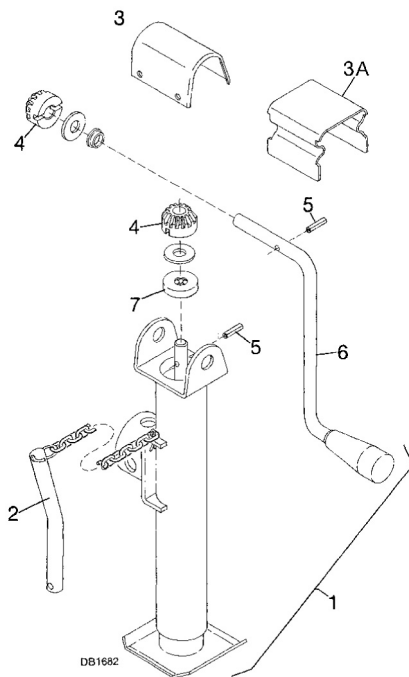
## D80-2 & MD80-2 IDLER PULLEY ASSEMBLY



REF	PART	QTY	DESCRIPTION
1	5586	1	Idler assembly complete
2	378	1	5/8 NC x 5 HHCS GR2
3	843	1	1/2 x 2 x 2 Square washer
4	844	2	Seal retainer
5	845	2	Felt seal
6	7016	1	Idler with bearings
7	232	2	Needle bearing
8	----- *	1	Grease fitting
9	377	1	Needle bearing sleeve
10	691	1	1/4 x 2 x 2 Square washer
11	230	1	5/8 NC Hex nut

\* Standard hardware, obtain locally

## D80-2 PARKING JACK



REF	PART	QTY	DESCRIPTION
1	23790	1	Swivel parking jack
2	25857	1	Jack hitch pin assembly
3	N/S	1	Jack gearbox cover
4	25859	2	15-Tooth bevel gear
5	25860	2	5/32 x 1-1/4 Drive pin
6	N/S	1	Jack crank handle
7	25862	1	Thrust bearing

N/S Not serviced

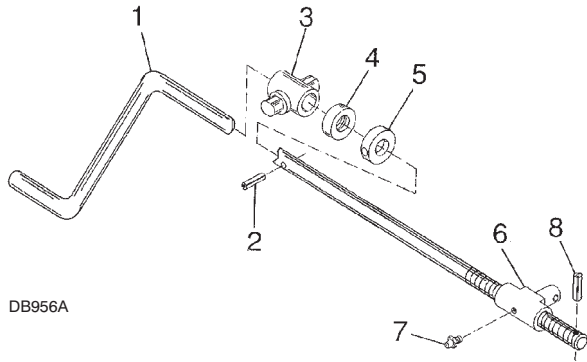
\* Standard hardware, obtain locally

**48 Parts**

15914 (Rev. 3/23/2007)



## D80-2 HEIGHT ADJUSTMENT CRANK

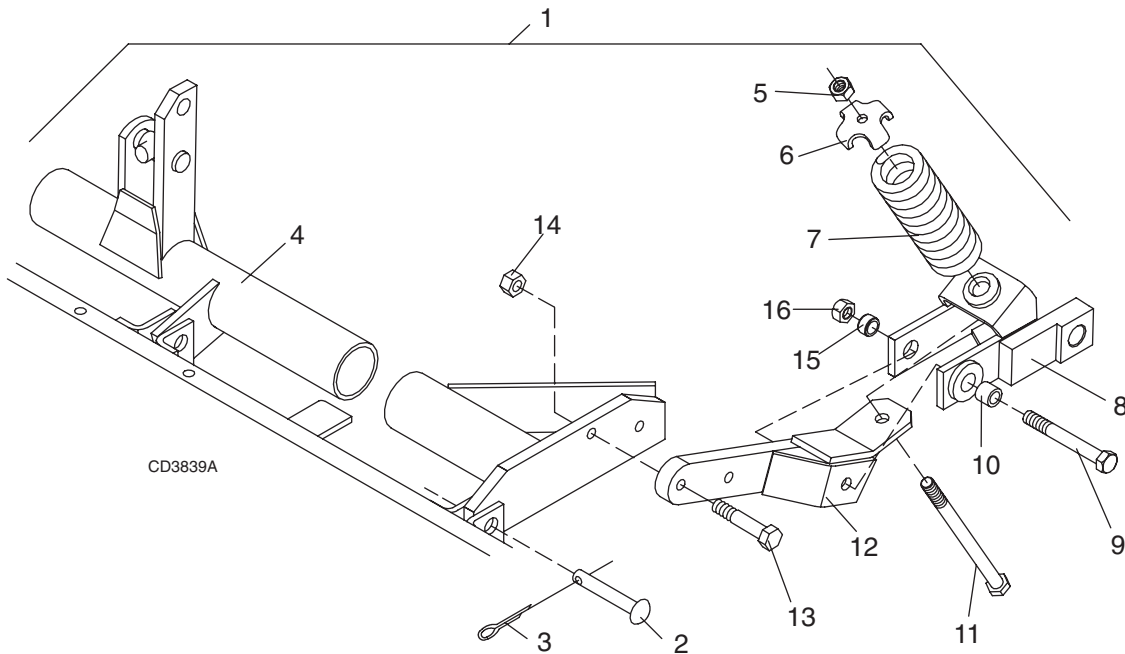


DB956A

REF	PART	QTY	DESCRIPTION
1	15804	1	Height adjustment crank
2	11880	1	5/16 x 1-3/4 Spirol pin
3	10417	1	Height adjustment pivot block
4	1893	1	Thrust bearing
5	1863	2	1" SAE Flat washer
6	5895	1	Height adjustment pivot nut
7	195*	1	Straight 1/8 pipe thread grease fitting
8	15134	1	1/4 x 1 Spirol pin

\* Obtain Locally - Standard Hardware

## D80-2 SPRING-LOADED WHEEL YOKE

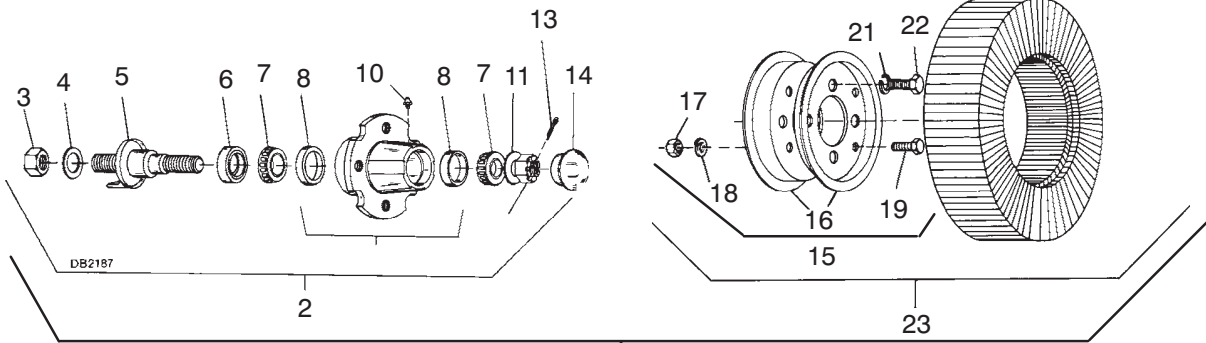


CD3839A

Ref No	Part No	No Used	Description	Ref No	Part No	No Used	Description
1	9310	1	Spring-loaded wheel yoke complete	10	2377	2	3/4 NC x 6 Hex head cap screw GR5
2	445	2	1 x 2-1/2 Clevis pin	11	39160	2	3/4 NC x 8.00 Hex head cap screw GR5
3	1285 *	2	1/4 x 1-1/2 Cotter pin	12	20086	1	Right spring yoke inner arm assembly
4	13906	1	Spring wheel yoke pipe assembly		-or-		-or-
5	2371 *	2	3/4 NC Hex locknut	12	20087	1	Left inner arm assembly
6	39097	2	.781 x .38 x 4.12 Square washer	13	986 *	4	5/8 NC x 2-3/4 Hex head cap screw GR5
7	13316	2	1/2 x 6 Compression spring	14	6239 *	4	5/8 NC Hex locknut
8	16302	1	Right outer arm assembly	15	10083	2	3/4 x 1-1/8 x 5/8 HT Bushing
	-or-		-or-	16	2371 *	1	3/4 NC Hex locknut
8	16303	1	Left outer arm assembly				
9	5560	2	3/4 x 1-1/8 x 31/32 HT Sleeve				

\* Obtain Locally

## D80-2 LAMINATED TIRE WITH HUB & AXLE

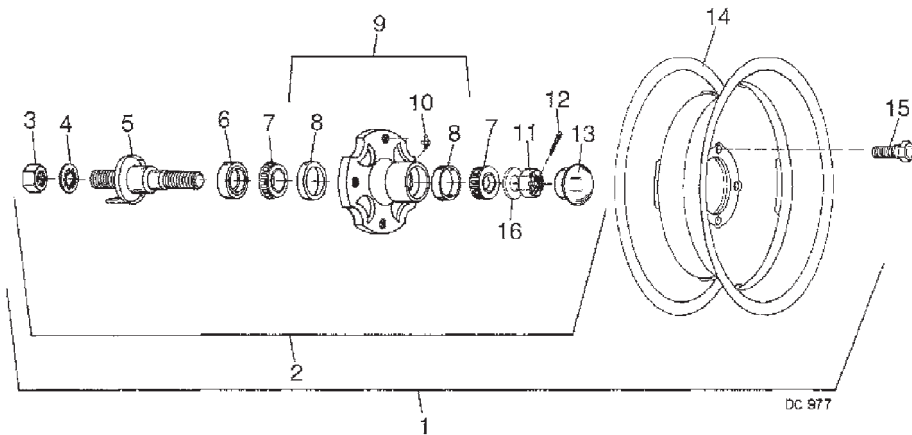


Ref No	Part No	No Used	Description
1	9373	1	6.00 x 9 Laminated tire w/hub & axle
2	4984	1	Heavy hub with long axle
3	3626	1	1-14 UNS Hex nut
4	3689 *	1	1" Standard lockwasher
5	6271	1	Long axle assembly for heavy hub
6	314	1	Seal for 1-1/2 shaft
7	310	2	Bearing cone #15126
8	309	2	Bearing cup #15245
9	530	1	Heavy wheel hub with bearing cups
10	1972 *	1	1/4-28 Tapered thread grease fitting
11	1257 *	2	3/4 Standard flat washer

Ref No	Part No	No Used	Description
12	5849	1	3/4 NF Slotted hex nut
13	1256 *	1	3/16 x 1 Cotter pin
14	531	1	Hub cap, heavy-duty
15	7431	1	Wheel rim w/hardware, 6.00 x 9
16	7430	2	Rim half for 6.00 x 9 tire
17	835 *	4	3/8 NC Hex nut, plated
18	838 *	4	3/8 Standard lockwasher
19	19887 *	4	3/8 NC x 1 Hex head cap screw GR
21	855 *	4	1/2 Extra-heavy lockwasher
22	4119	4	1/2 NF x 1 Hex head cap screw GR
23	7428	1	6.00 x 9 Solid tire and rim

\* Obtain Locally

## D80-2 RIM & AXLE ASSEMBLY



Ref No	Part No	No Used	Description
1	2315	1	15" Wheel rim, cast hub & axle
2	2302	1	Standard wheel hub & axle
3	3626	1	1-14 UNS Hex nut
4	3689 *	1	1" Standard lockwasher
5	2301	1	Axle for standard hub
6	6273	1	Seal for 1-1/2 shaft
7	2303	1	Bearing cone #LM67048
8	2305	1	Bearing cup #LM67010

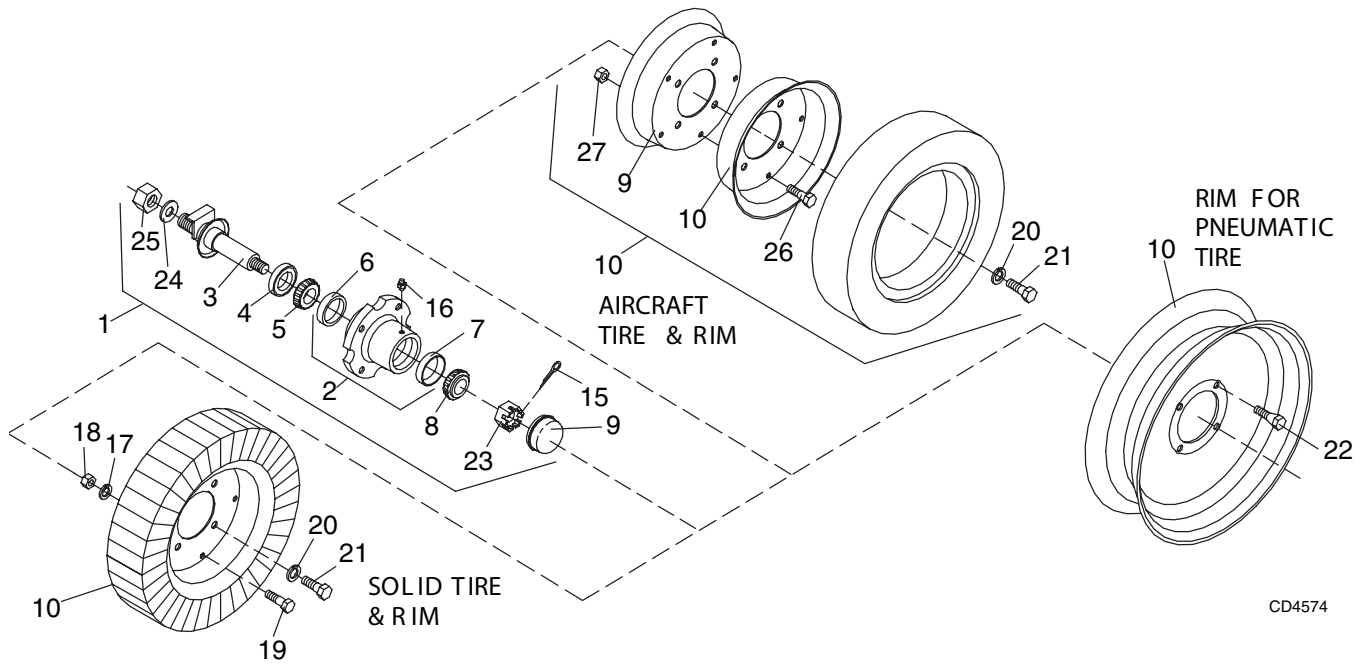
Ref No	Part No	No Used	Description
9	2307	1	Cast hub with cups
10	1972 *	1	1/4-28 Tapered thread grease fitting
11	5849	1	3/4 NF Slotted hex nut
12	1256 *	1	3/16 x 1 Cotter pin
13	6248	1	Hub cap, standard
14	529	1	15" 4-Hole rim
15	1258	4	1/2 NF x 1-1/8 Wheel bolt
16	2864 *	1	3/4 SAE Flat washer

\* Obtain Locally

# 50 Parts

15914 (Rev. 3/23/2007)

## D80-2 AIRCRAFT TIRE & HUB

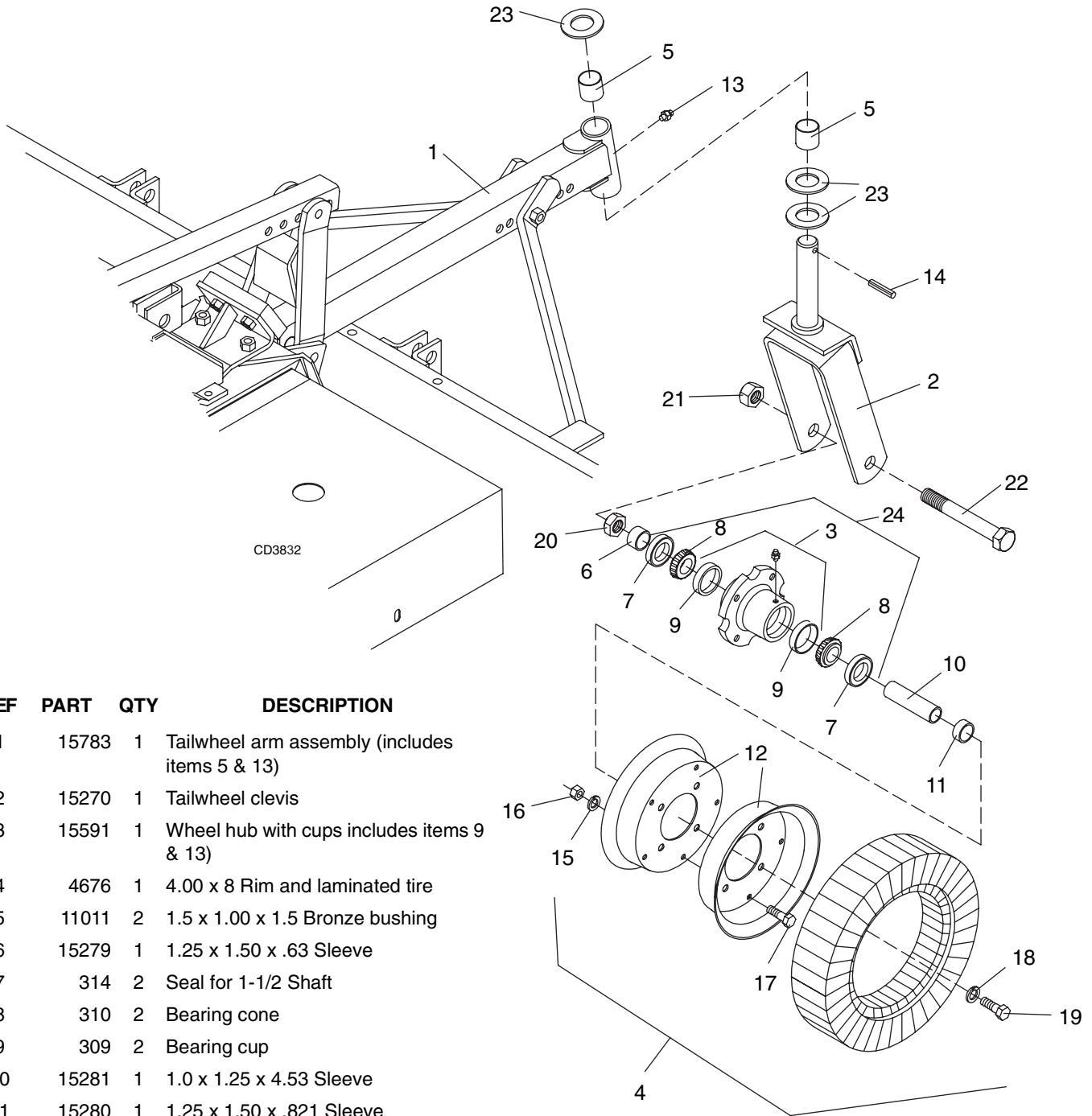


CD4574

### HARDWARE

REF	PART	QTY	DESCRIPTION	REF	PART	DESCRIPTION
1	12080	1	Standard hub with long axle	17	838	*† 3/8 Standard lock washer
2	2307	1	Hub with cups	18	835	*† 3/8 NC Hex nut, plated
3	12081	1	Wing axle assembly	19	19887	† 3/8 NC x 1 HHCS GR8
4	6273	1	Seal for 1-1/2 shaft	20	855	*‡ 1/2 Extra-heavy lock washer
5	2303	1	Bearing cone	21	4358	‡ 1/2 NF x 1-1/4 HHCS GR5 (solid tire only)
6	2305	1	Bearing cup	22	1258	1/2 NF x 1-1/8 Wheel bolt (pneumatic rim only)
7	2306	1	Bearing cup	23	5849	3/4 NF Slotted hex nut
8	2304	1	Bearing cone	24	3689	1" Standard lock washer
9	6248	1	Hub cap	25	3626	1-14 UNS Hex nut
10	529	1	15" 4-Hole rim for pneumatic tire <b>-or-</b>	26	----	* 9/16 NC x 1-1/4 HHCS (for aircraft wheel)
10	7428	1	6.00 x 9 Solid tire, rim & hardware <b>-or-</b>	27	----	* 9/16 NC Hex lock nut (for aircraft wheel)
10	1003695	1	Wheel assembly 22 x 6.6 x 10.0			* Obtain Locally - Standard Hardware
10A	1015834	1	Inner tube for #1003695 wheel			† Used on Solid Wheel Only
11	1003694	1	Rim half, aircraft wheel			‡ Used on Solid and Aircraft Wheels only
12	1003693	1	Rim half with valve hole, aircraft wheel			
15	1256	*	3/16 x 1 Cotter pin			
16	1972	*	1/4 - 28 Tapered thread grease fitting			

# MD80-2 TAILWHEEL ASSEMBLY



REF	PART	QTY	DESCRIPTION
1	15783	1	Tailwheel arm assembly (includes items 5 & 13)
2	15270	1	Tailwheel clevis
3	15591	1	Wheel hub with cups includes items 9 & 13)
4	4676	1	4.00 x 8 Rim and laminated tire
5	11011	2	1.5 x 1.00 x 1.5 Bronze bushing
6	15279	1	1.25 x 1.50 x .63 Sleeve
7	314	2	Seal for 1-1/2 Shaft
8	310	2	Bearing cone
9	309	2	Bearing cup
10	15281	1	1.0 x 1.25 x 4.53 Sleeve
11	15280	1	1.25 x 1.50 x .821 Sleeve
12	4679	2	Rim half
13	1972*	-	1/4-28 Tapered thread grease fitting
14	4674	-	3/8 x 2 Spirol pin
15	838*	-	3/8 Standard lockwasher
16	835*	-	3/8 Hex nut, plated
17	839*	-	3/8 NC x 1 HHCS GR5
18	855*	-	1/2 Heavy lockwasher
19	4119	-	1/2 NF x 1 HHCS GR5
20	1386	-	1" NC Hex jam nut

REF	PART	QTY	DESCRIPTION
21	34279	-	1" NC Hex locknut
22	15278	-	1" NC x 7-1/2 HHCS GR5
23	2370	-	.18 x 1.62 ID x 3 OD Washer
24	15277	1	Wheel hub assembly (includes items 7, 8, 9 & 13)

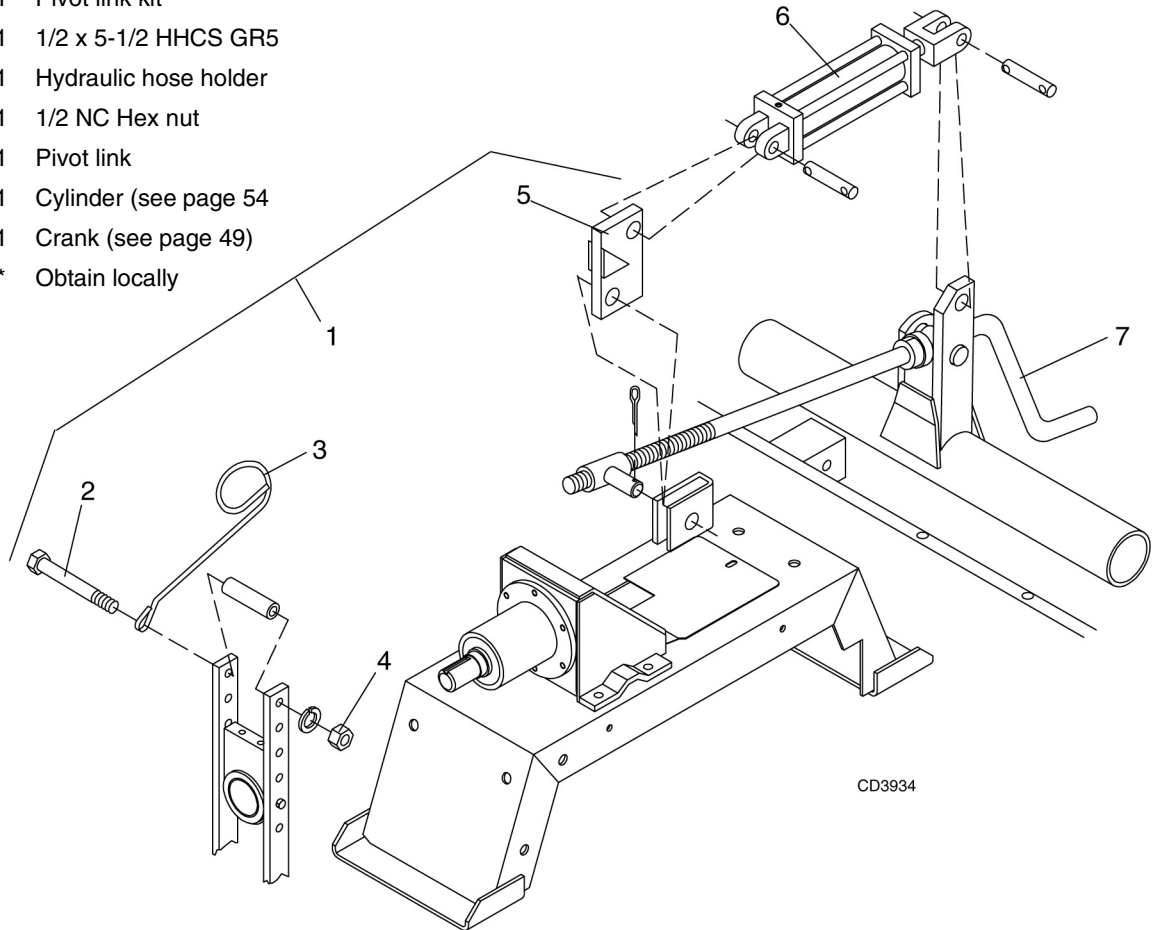
\* Obtain Locally - Standard Hardware

**52 Parts**

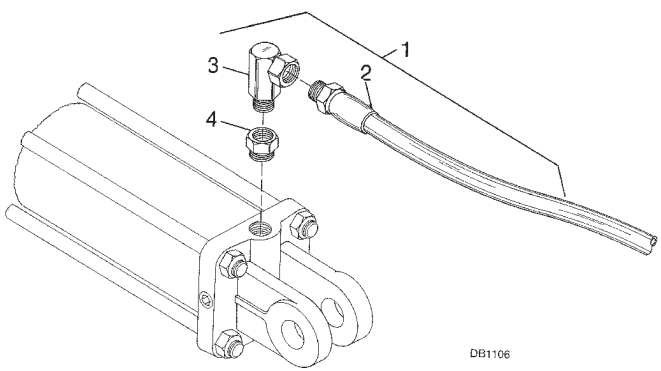
15914 (Rev. 3/23/2007)

## D80-2 PIVOT LINK KIT (OPTIONAL)

REF	PART	QTY	DESCRIPTION
1	8751	1	Pivot link kit
2	12305 *	1	1/2 x 5-1/2 HHCS GR5
3	3443	1	Hydraulic hose holder
4	1093	1	1/2 NC Hex nut
5	15792	1	Pivot link
6	----	1	Cylinder (see page 54)
7	----	1	Crank (see page 49)
			* Obtain locally

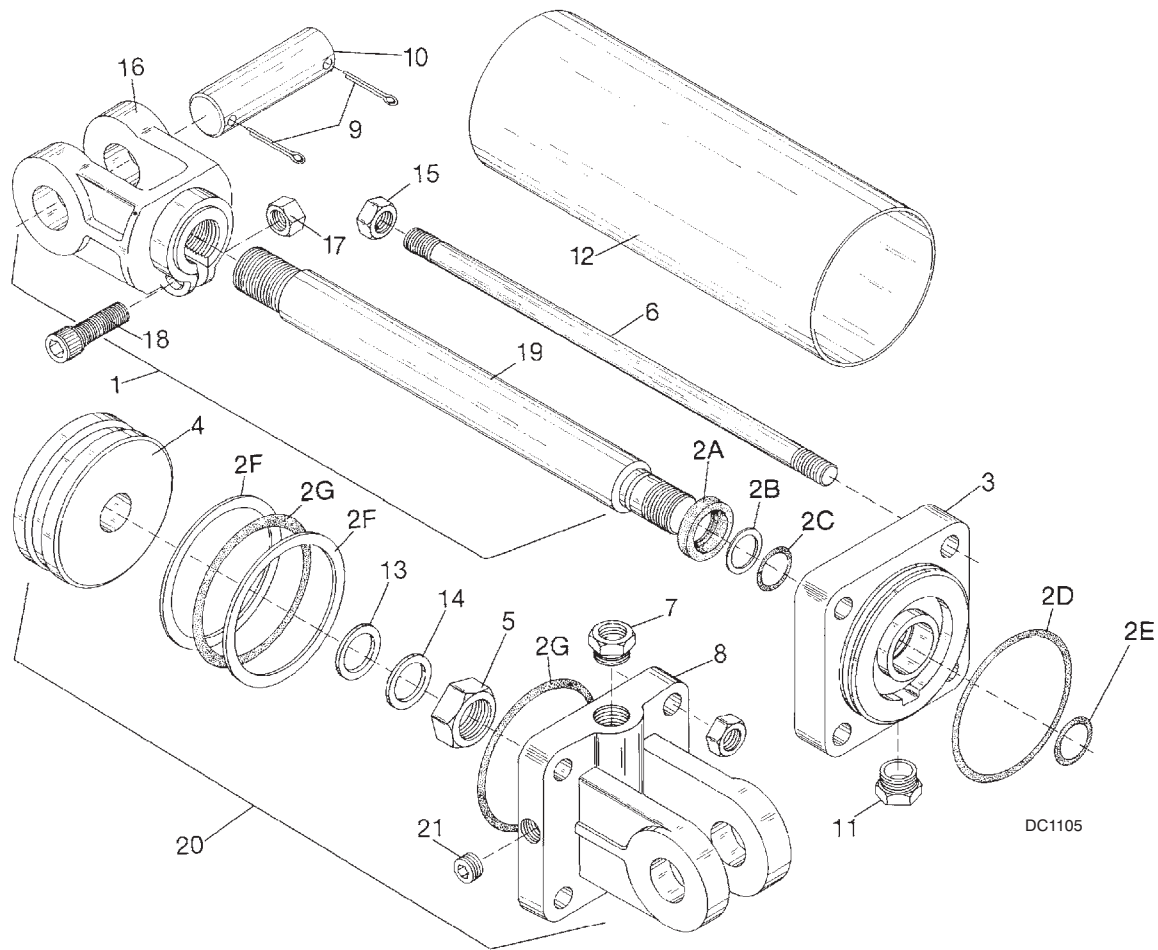


## D80-2 HYDRAULIC HOSE KIT & FITTINGS (OPTIONAL)



REF	PART	QTY	DESCRIPTION
1	17601	1	1/4 x 108 Hydraulic hose kit and fittings
2	17628	1	1/4 NPT x 108 Hydraulic hose assembly
3	10290	1	1/4 x 1/4 x 90-degree Elbox with 1/16 restrictor
4	11893*	1	1/4 x 1/2 Pipe reducer bushing
			* Obtain Locally - Standard Hardware

## D80-2 3-1/2 X 8" HYDRAULIC CYLINDER #10475 (OPTIONAL)



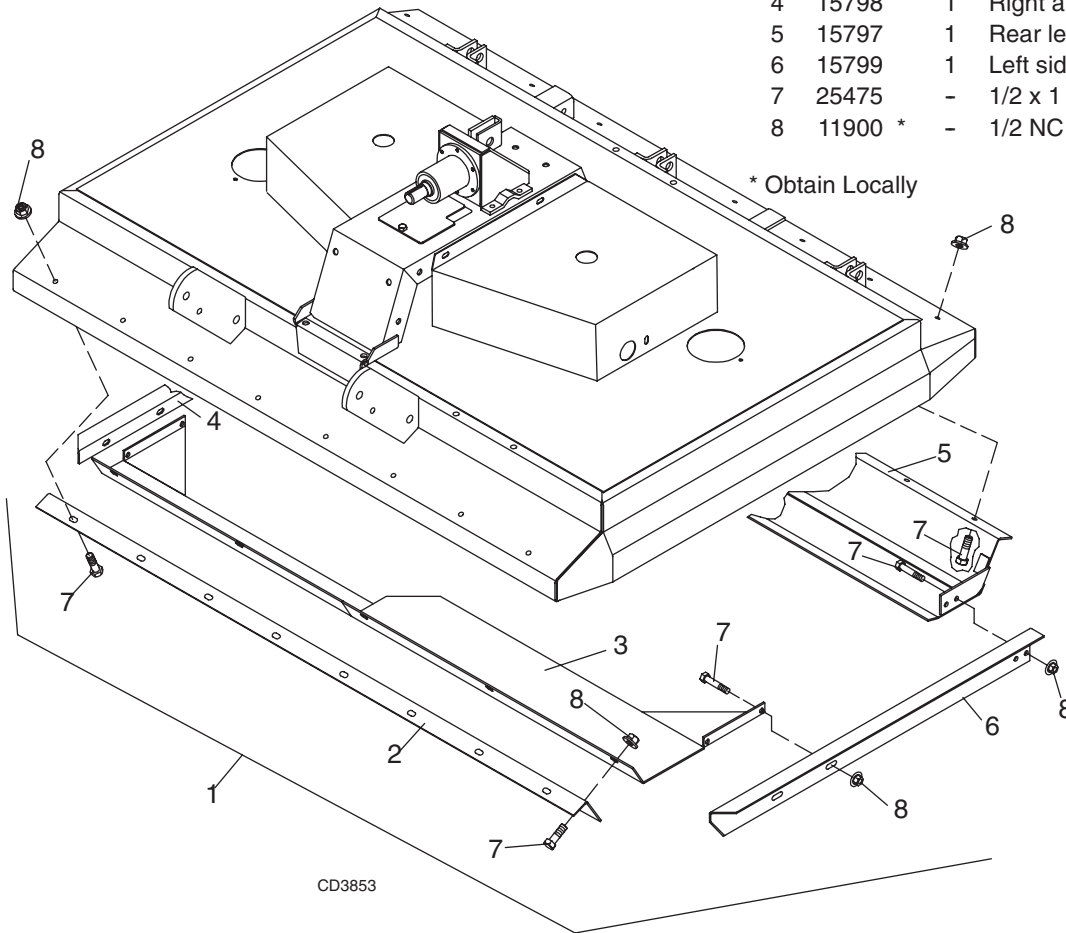
REF	PART	QTY	DESCRIPTION	REF	PART	QTY	DESCRIPTION
1	----	-	Not available	10	1631	2	1 x 3-5/8 Clevis pin
2	26340	1	Seal kit (includes 2A thru 2G)	11	11975	1	1/2 NPT Vent plug <b>-or-</b>
2A	†	1	1-1/4 ID Wiper seal	11	23547	1	1/4 NPT Vent plug
2B	†	1	Rod back-up ring	12	26342	1	Cylinder barrel
2C	†	2	1-1/4 ID O-ring	13	----	-	Not required
2D	†	2	3/16 x 3-1/2 OD O-ring	14	----	-	Not required
2E	†	1	3/32 x 3/4 OD O-ring	15	4391	8	1/2 NF Hex jam nut
2F	†	2	3-1/2 OD Back-up washer	16	25661	1	Cylinder rod clevis
2G	†	1	Piston seal o-ring	17	6698*	1	3/8 NC Hex locknut
3	26338	1	Rod end housing	18	23550*	1	3/8 NC x 1-1/2 Socket head cap screw
4	25497	1	Piston	19	26343	1	Cylinder rod
5	25496	1	1-14 UNS Jam nut	20	10475	1	Hydraulic cylinder complete (single-acting)
6	26341	4	Tie rod	21	4510*	1	1/2 Pipe plug
7	11893*	1	1/2 x 1/4 Pipe reducer bushing				* Obtain Locally - Standard Hardware
8	25494	1	Cylinder butt end				† Included in Seal Kit
9	923*	4	1/4 x 1-3/4 Cotter pin				

**54 Parts**

15914 (Rev. 3/23/2007)

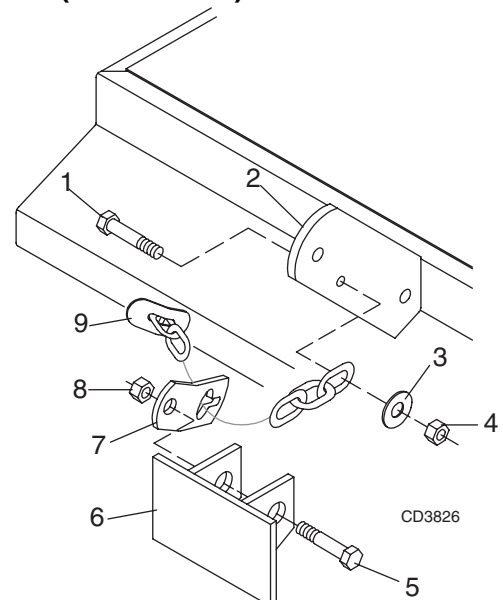
## D80-2 & MD80-2 LEAF MULCHER ASSEMBLY (OPTIONAL)

Ref No	Part No	No Used	Description
1	8757	1	Leaf mulcher complete
2	29089	1	Leaf mulcher adapter
3	1298	1	Front shield
4	15798	1	Right angle leaf mulcher
5	15797	1	Rear leaf mulcher
6	15799	1	Left side angle leaf mulcher
7	25475	-	1/2 x 1 Hex head cap screw GR5
8	11900 *	-	1/2 NC Flanged hex locknut

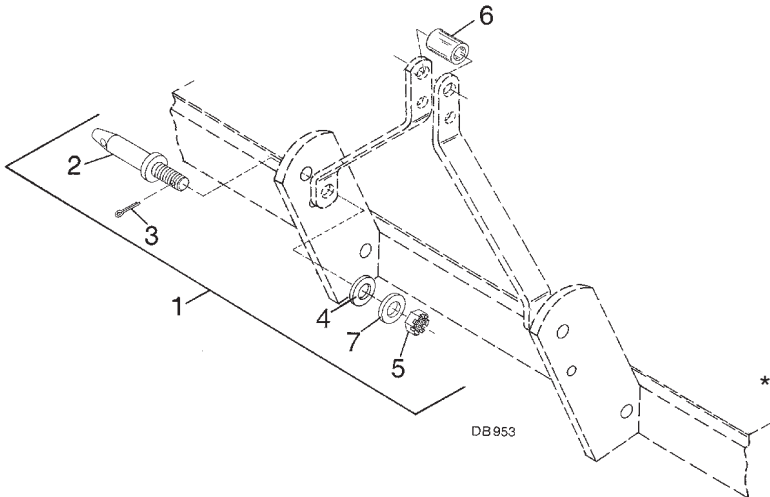


## MD80-2 CHECK CHAIN ASSEMBLY (OPTIONAL)

REF	PART	QTY	DESCRIPTION
-	10521	-	Check chain kit complete
1	12274	-	5/8 x 2-1/4 Bolt
2	-----	-	Cutter mast plate
3	3632	-	5/8 Flat washer
4	6239	-	5/8 Hex locknut
5	2377	-	3/4 x 6 Bolt
6	-----	-	Tractor top link bracket
7	7906	2	Check chain bracket
8	2371	-	3/4 Hex locknut
9	18048	2	3/8 Chain, 32-link
			* Obtain Locally - Standard Hardware



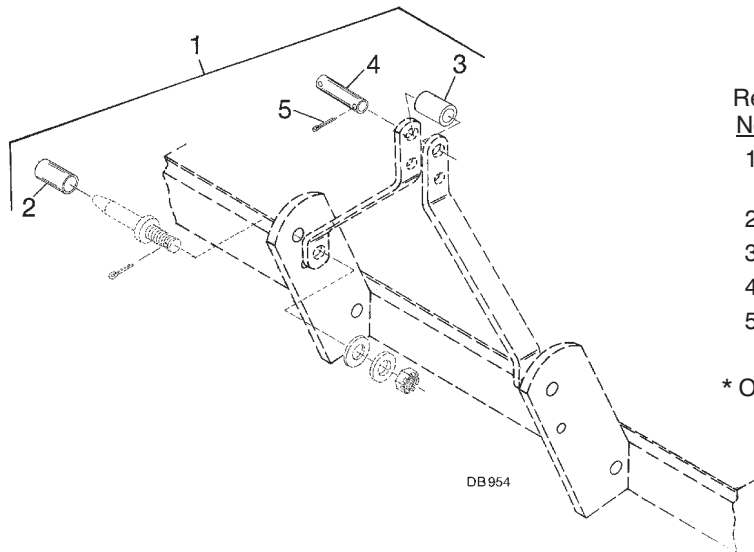
## MD80-2 CATEGORY 2 HITCH PIN OPTIONS



<u>Ref No</u>	<u>Part No</u>	<u>No Used</u>	<u>Description</u>
1	13010	1	Category 2 hitch pin mounting kit
2	12275	2	Category 2 mounting pin, 6" long
3	1266 *	2	3/16 x 1-1/2 Cotter pin
4	13011	2	7/8 x 2-3/8 x 3/16 Flat washer
5	13012	2	7/8 NF Castle hex nut
6	7372	1	25/32 x 1 x 2 Sleeve

\* Obtain Locally

## MD80-2 CATEGORY 2 BUSHING KIT



<u>Ref No</u>	<u>Part No</u>	<u>No Used</u>	<u>Description</u>
1	7112	1	Category 2 hitch bushing adapter kit
2	3253	2	7/8 x 1-1/8 x 1-3/4 Sleeve
3	7372	1	25/32 x 1 x 2 Sleeve
4	1591	1	3/4 x 4-3/8 Clevis pin
5	1266 *	2	3/16 x 1-1/2 Cotter pin

\* Obtain Locally



# BOLT TORQUE CHART

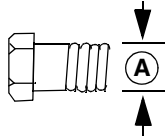
Always tighten hardware to these values unless a different torque value or tightening procedure is listed for a specific application.

Fasteners must always be replaced with the same grade as specified in the manual parts list.

Always use the proper tool for tightening hardware: SAE for SAE hardware and Metric for metric hardware.

Make sure fastener threads are clean and you start thread engagement properly.

All torque values are given to specifications used on hardware defined by SAE J1701 MAR 99 & J1701M JUL 96.



## SAE SERIES TORQUE CHART



SAE Grade 2  
(No Dashes)

SAE Bolt Head Identification

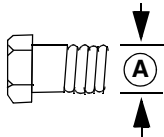


SAE Grade 5  
(3 Radial Dashes)



SAE Grade 8  
(6 Radial Dashes)

Ⓐ Diameter (Inches)	Wrench Size	MARKING ON HEAD					
		SAE 2		SAE 5		SAE 8	
		lbs-ft	N-m	lbs-ft	N-m	lbs-ft	N-m
1/4"	7/16"	6	8	10	13	14	18
5/16"	1/2"	12	17	19	26	27	37
3/8"	9/16"	23	31	35	47	49	67
7/16"	5/8"	36	48	55	75	78	106
1/2"	3/4"	55	75	85	115	120	163
9/16"	13/16"	78	106	121	164	171	232
5/8"	15/16"	110	149	170	230	240	325
3/4"	1-1/8"	192	261	297	403	420	569
7/8"	1-5/16"	306	416	474	642	669	907
1"	1-1/2"	467	634	722	979	1020	1383



## METRIC SERIES TORQUE CHART



8.8  
Metric  
Grade 8.8

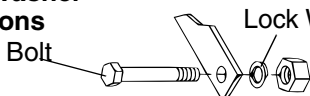
Metric Bolt Head Identification



10.9  
Metric  
Grade 10.9

Ⓐ Diameter & Thread Pitch (Millimeters)	Wrench Size	COARSE THREAD				FINE THREAD				Ⓐ Diameter & Thread Pitch (Millimeters)
		MARKING ON HEAD								
		Metric 8.8		Metric 10.9		Metric 8.8		Metric 10.9		
		N-m	lbs-ft	N-m	lbs-ft	N-m	lbs-ft	N-m	lbs-ft	
6 x 1.0	10 mm	8	6	11	8	8	6	11	8	6 x 1.0
8 x 1.25	13 mm	20	15	27	20	21	16	29	22	8 x 1.0
10 x 1.5	16 mm	39	29	54	40	41	30	57	42	10 x 1.25
12 x 1.75	18 mm	68	50	94	70	75	55	103	76	12 x 1.25
14 x 2.0	21 mm	109	80	151	111	118	87	163	120	14 x 1.5
16 x 2.0	24 mm	169	125	234	173	181	133	250	184	16 x 1.5
18 x 2.5	27 mm	234	172	323	239	263	194	363	268	18 x 1.5
20 x 2.5	30 mm	330	244	457	337	367	270	507	374	20 x 1.5
22 x 2.5	34 mm	451	332	623	460	495	365	684	505	22 x 1.5
24 x 3.0	36 mm	571	421	790	583	623	459	861	635	24 x 2.0
30 x 3.0	46 mm	1175	867	1626	1199	1258	928	1740	1283	30 x 2.0

### Typical Washer Installations



Lock Washer

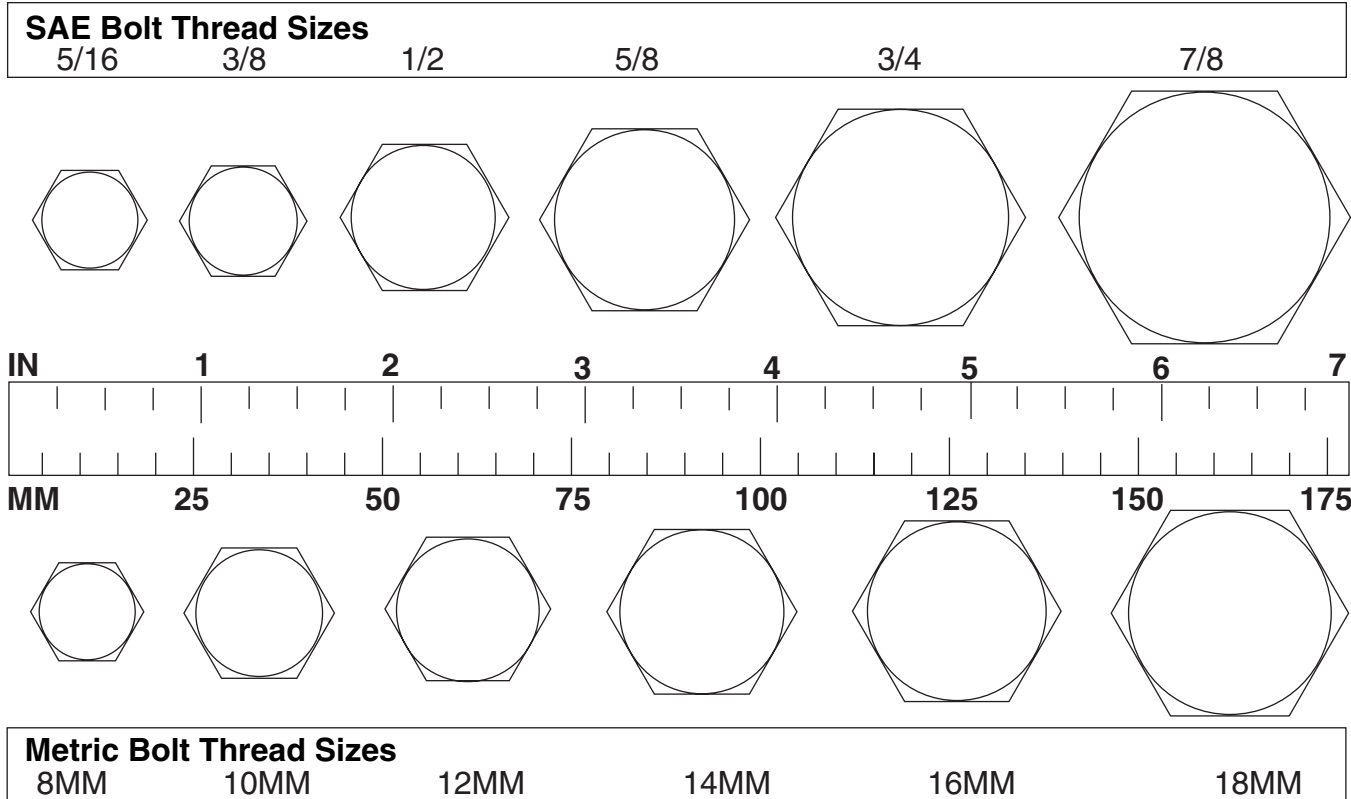
Flat Washer



8/9/00

# BOLT SIZE CHART

**NOTE:** Chart shows bolt thread sizes and corresponding head (wrench) sizes for standard SAE and metric bolts.



## ABBREVIATIONS

AG ..... Agriculture  
 ASABE ..... American Society of Agricultural & Biological Engineers (formerly ASAE)  
 ASAE..... American Society of Agricultural Engineers  
 ATF.....Automatic Transmission Fluid  
 BSPP..... British Standard Pipe Parallel  
 BSPTM..... British Standard Pipe Tapered Male  
 CV ..... Constant Velocity  
 CCW..... Counter-Clockwise  
 CW ..... Clockwise  
 F ..... Female  
 FT..... Full Thread  
 GA ..... Gauge  
 GR (5, etc.)..... Grade (5, etc.)  
 HHCS ..... Hex Head Cap Screw  
 HT ..... Heat-Treated  
 JIC..... Joint Industry Council 37° Degree Flare  
 LH..... Left Hand  
 LT ..... Left  
 m ..... Meter  
 mm ..... Millimeter  
 M ..... Male

MPa ..... Mega Pascal  
 N ..... Newton  
 NC..... National Coarse  
 NF ..... National Fine  
 NPSM ..... National Pipe Straight Mechanical  
 NPT.....National Pipe Tapered  
 NPT SWF..... National Pipe Tapered Swivel Female  
 ORBM ..... O-Ring Boss - Male  
 P ..... Pitch  
 PBY.....Power-Beyond  
 psi ..... Pounds per Square Inch  
 PTO.....Power Take Off  
 QD ..... Quick Disconnect  
 RH..... Right Hand  
 ROPS..... Roll-Over Protective Structure  
 RPM.....Revolutions Per Minute  
 RT ..... Right  
 SAE..... Society of Automotive Engineers  
 UNC ..... Unified Coarse  
 UNF ..... Unified Fine  
 UNS ..... Unified Special

# INDEX

## ASSEMBLY 28

- Dealer Set-Up Instructions 28
  - Blade Installation 28
  - Chain Shielding Installation 29
  - Distribution Baffle Installation 28
  - Gearbox Lubrication 29
  - MD80 Assembly 33
  - Optional Hydraulic Installation for D80-2 Pull-Type Cutter 32
  - Tongue Installation for D80-2 Pull-Type Cutter 31
  - Wheel Yoke Installation for D80-2 Pull-Type Cutter 30
- Optional Check Chain Installation 35
- Optional Leaf Mulcher Installation 34

## DEALER CHECK LISTS 36

- Delivery 36
- Pre-Delivery 36

## DEALER SERVICE 22

- Blade Spindle Repair 23
  - Assembly 23
- Gearbox Maintenance 22
  - Bearing Check 22
  - Damage Inspection 22
  - Gearbox Adjustment 23
  - Gearbox Assembly 23
  - Gearbox Disassembly 22
  - Leakage Repair 22
  - Possible Leakage Causes 22
  - Removing Gearbox from Cutter 22
  - Seal Installation 23
- Servicing Tires Safely 26
- Shield Bearing Service 24
- Troubleshooting 27
- Universal Joint Repair 24
  - U-Joint Assembly 25
  - U-Joint Disassembly 24

## GENERAL

- Abbreviations 58
- Bolt Size Chart 58

- Bolt Torque Chart 57
- Introduction 2
- Obtaining Replacement Manuals 2
- Warranty
  - Product 60
  - Replacement Parts 61

## OPERATION 13

- Attaching Mounted Cutter to Tractor 13
  - Cutting Height Adjustment
    - For MD80 Mounted Cutter 15
    - With Tailwheel or Check Chains 15
    - Without Tail-wheel or Check Chains 15
  - MD80 Mounting 13
- Attaching Pull-Type Cutter to Tractor 15
  - Cutting Height Adjustment
    - For D80 Pull-Type Cutter 16
- Operating technique 16
  - Tips 17
  - Uneven Terrain 17
- Pre-Operation Check List 16
- Starting and stopping Cutter 16
- Storage 17
- Tractor Stability 13

## OWNER SERVICE

- Blade Servicing 18
  - Blade Installation 20
  - Blade Removal 19
  - Blade Sharpening 20
- Chain Shielding 20
- Lubrication Information 18
- Servicing Tires Safely 21

## SAFETY

- Check Lists
  - Delivery 36
  - Pre-Delivery 36
  - Pre-Operation 16
- Free Mower Safety Video Order Form 5, 6
- Safety & Instructional Decals 10
- Safety Rules 7
- Safety Symbols Explained 2

# WARRANTY

(All Models Except Mow'n Machine™ Zero-Turn Mowers and Woods Boundary™ Utility Vehicles)

Please Enter Information Below and Save for Future Reference.

Date Purchased: \_\_\_\_\_ From (Dealer): \_\_\_\_\_

Model Number: \_\_\_\_\_ Serial Number: \_\_\_\_\_

Woods Equipment Company ("WOODS") warrants this product to be free from defect in material and workmanship. Except as otherwise set forth below, the duration of this Warranty shall be for TWELVE (12) MONTHS COMMENCING ON THE DATE OF DELIVERY OF THE PRODUCT TO THE ORIGINAL PURCHASER.

Woods backhoe models BH70-X, BH80-X, and BH90-X are warranted for two (2) years from the date of delivery to the original purchaser.

The warranty periods for specific parts or conditions are listed below:

Model Number	Part or Condition Warranted	Duration (from date of delivery to the original purchaser)
PHD25, PHD35, PHD65, PHD95, 1260, 2162, 3240, BB48, BB60, BB72, BB84, BB600, BB720, BB840, BB6000, BB7200, BB8400, BW180-2, BW1800, DS96, DS120, DS1260, DSO1260, DS1440, TS1680, RCC42, RM550-2, RM660-2, RM990-3, PRD6000, PRD7200, PRD8400, 7144RD-2, 9180RD-2, 9204RD-2, S15CD, S20CD, S22CD, S25CD, S27CD	Gearbox components	5 years
RDC54, RD60, RD72	Gearbox components	3 years (1 year if used in rental or commercial applications)
RM550-2, RM660-2, RM990-3, PRD6000, PRD7200, PRD8400, 7144RD-2, 9180RD-2, 9204RD-2	Blade spindles	3 years
BB600, BB720, BB840, BB6000, BB7200, BB8400, BW126, BW180, BW1260, BW1800, 1260, 2162, 3240	Rust-through	10 years

Under no circumstances will this Warranty apply in the event that the product, in the good faith opinion of WOODS, has been subjected to improper operation, improper maintenance, misuse, or an accident. This Warranty does not apply in the event that the product has been materially modified or repaired by someone other than WOODS, a WOODS authorized dealer or distributor, and/or a WOODS authorized service center. This Warranty does not cover normal wear or tear, or normal maintenance items. This Warranty also does not cover repairs made with parts other than those obtainable through WOODS.

This Warranty is extended solely to the original purchaser of the product. Should the original purchaser sell or otherwise transfer this product to a third party, this Warranty does not transfer to the third party purchaser in any way. There are no third party beneficiaries of this Warranty.

WOODS makes no warranty, express or implied, with respect to engines, batteries, tires or other parts or accessories not manufactured by WOODS. Warranties for these items, if any, are provided separately by their respective manufacturers.

WOODS' obligation under this Warranty is limited to, at WOODS' option, the repair or replacement, free of charge, of the product if WOODS, in its sole discretion, deems it to be defective or in noncompliance with this Warranty. **The product must be returned to WOODS with proof of purchase within thirty (30) days after such defect or noncompliance is discovered or should have been discovered, routed through the dealer and distributor from whom the purchase was made, transportation charges prepaid.** WOODS shall complete such repair or replacement within a reasonable time after WOODS receives the product. THERE ARE NO OTHER REMEDIES UNDER THIS WARRANTY. THE REMEDY OF REPAIR OR REPLACEMENT IS THE SOLE AND EXCLUSIVE REMEDY UNDER THIS WARRANTY.

THERE ARE NO WARRANTIES WHICH EXTEND BEYOND THE DESCRIPTION ON THE FACE OF THIS WARRANTY. WOODS MAKES NO OTHER WARRANTY, EXPRESS OR IMPLIED, AND WOODS SPECIFICALLY DISCLAIMS ANY IMPLIED WARRANTY OF MERCHANTABILITY AND/OR ANY IMPLIED WARRANTY OF FITNESS FOR A PARTICULAR PURPOSE.

**WOODS shall not be liable for any incidental or consequential losses, damages or expenses, arising directly or indirectly from the product, whether such claim is based upon breach of contract, breach of warranty, negligence, strict liability in tort or any other legal theory.** Without limiting the generality of the foregoing, Woods specifically disclaims any damages relating to (i) lost profits, business, revenues or goodwill; (ii) loss of crops; (iii) loss because of delay in harvesting; (iv) any expense or loss incurred for labor, supplies, substitute machinery or rental; or (v) any other type of damage to property or economic loss.

This Warranty is subject to any existing conditions of supply which may directly affect WOODS' ability to obtain materials or manufacture replacement parts.

No agent, representative, dealer, distributor, serviceperson, salesperson, or employee of any company, including without limitation, WOODS, its authorized dealers, distributors, and service centers, is authorized to alter, modify, or enlarge this Warranty.

Answers to any questions regarding warranty service and locations may be obtained by contacting:

**Woods Equipment Company**

2606 South Illinois Route 2  
Post Office Box 1000  
Oregon, Illinois 61061

800-319-6637 tel  
800-399-6637 fax  
www.WoodsEquipment.com



- ALITEC™**
- BMP®**
- CENTRAL FABRICATORS®**
- GANNON®**
- GILL®**
- WAIN-ROY®**
- WOODS®**



## WARRANTY

(Replacement Parts For All Models Except Mow'n Machine™  
Zero-Turn Mowers and Woods Boundary™ Utility Vehicles)

Woods Equipment Company ("WOODS") warrants this product to be free from defect in material and workmanship for a period of ninety (90) days from the date of delivery of the product to the original purchaser with the exception of V-belts, which will be free of defect in material and workmanship for a period of 12 months.

Under no circumstances will this Warranty apply in the event that the product, in the good faith opinion of WOODS, has been subjected to improper operation, improper maintenance, misuse, or an accident. This Warranty does not cover normal wear or tear, or normal maintenance items.

This Warranty is extended solely to the original purchaser of the product. Should the original purchaser sell or otherwise transfer this product to a third party, this Warranty does not transfer to the third party purchaser in any way. There are no third party beneficiaries of this Warranty.

WOODS' obligation under this Warranty is limited to, at WOODS' option, the repair or replacement, free of charge, of the product if WOODS, in its sole discretion, deems it to be defective or in noncompliance with this Warranty. **The product must be returned to WOODS with proof of purchase within thirty (30) days after such defect or noncompliance is discovered or should have been discovered, routed through the dealer and distributor from whom the purchase was made, transportation charges prepaid.** WOODS shall complete such repair or replacement within a reasonable time after WOODS receives the product. THERE ARE NO OTHER REMEDIES UNDER THIS WARRANTY. THE REMEDY OF REPAIR OR REPLACEMENT IS THE SOLE AND EXCLUSIVE REMEDY UNDER THIS WARRANTY.

THERE ARE NO WARRANTIES WHICH EXTEND BEYOND THE DESCRIPTION ON THE FACE OF THIS WARRANTY. WOODS MAKES NO OTHER WARRANTY, EXPRESS OR IMPLIED, AND WOODS SPECIFICALLY DISCLAIMS ANY IMPLIED WARRANTY OF MERCHANTABILITY AND/OR ANY IMPLIED WARRANTY OF FITNESS FOR A PARTICULAR PURPOSE.

**WOODS shall not be liable for any incidental or consequential losses, damages or expenses, arising directly or indirectly from the product, whether such claim is based upon breach of contract, breach of warranty, negligence, strict liability in tort or any other legal theory.** Without limiting the generality of the foregoing, Woods specifically disclaims any damages relating to (i) lost profits, business, revenues or goodwill; (ii) loss of crops; (iii) loss because of delay in harvesting; (iv) any expense or loss incurred for labor, supplies, substitute machinery or rental; or (v) any other type of damage to property or economic loss.

This Warranty is subject to any existing conditions of supply which may directly affect WOODS' ability to obtain materials or manufacture replacement parts.

No agent, representative, dealer, distributor, service person, salesperson, or employee of any company, including without limitation, WOODS, its authorized dealers, distributors, and service centers, is authorized to alter, modify, or enlarge this Warranty.

Answers to any questions regarding warranty service and locations may be obtained by contacting:

### Woods Equipment Company

2606 South Illinois Route 2  
Post Office Box 1000  
Oregon, Illinois 61061

800-319-6637 tel  
800-399-6637 fax  
[www.WoodsEquipment.com](http://www.WoodsEquipment.com)

**ALITEC™**

**BMP®**

**CENTRAL FABRICATORS®**

**GANNON®**

**GILL®**

**WAIN-ROY®**

**WOODS®**

**15914**

**Woods Equipment  
Company**

2606 South Illinois Route 2  
Post Office Box 1000  
Oregon, Illinois 61061

815-732-2141 tel  
815-732-7580 fax  
[www.WoodsEquipment.com](http://www.WoodsEquipment.com)

**WOODS®**

© 1996 Woods Equipment Company. All rights reserved. WOODS, the Woods logo, and "Tested. Proven. Unbeatable." are trademarks of Woods Equipment Company. All other trademarks, trade names, or service marks not owned by Woods Equipment Company that appear in this manual are the property of their respective companies or mark holders. Specifications subject to change without notice.

## Free Manuals Download Website

<http://myh66.com>

<http://usermanuals.us>

<http://www.somanuals.com>

<http://www.4manuals.cc>

<http://www.manual-lib.com>

<http://www.404manual.com>

<http://www.luxmanual.com>

<http://aubethermostatmanual.com>

Golf course search by state

<http://golfingnear.com>

Email search by domain

<http://emailbydomain.com>

Auto manuals search

<http://auto.somanuals.com>

TV manuals search

<http://tv.somanuals.com>