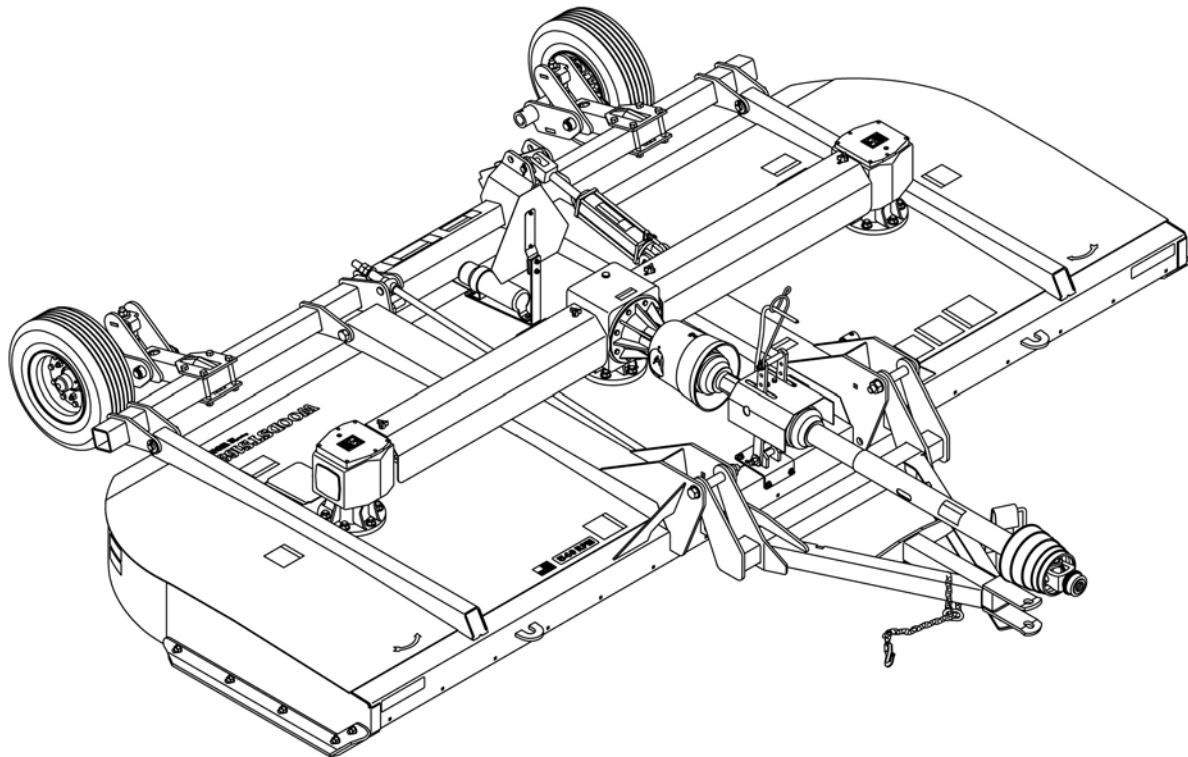


# WOODS ROTARY CUTTER

**TS1680**  
**TS1680Q**



**MAN0577**  
(Rev. 10/18/2010)

**WOODS**<sup>®</sup>  
Tested. Proven. Unbeatable.

OPERATOR'S MANUAL

## TO THE DEALER:

Assembly and proper installation of this product is the responsibility of the Woods® dealer. Read manual instructions and safety rules. Make sure all items on the Dealer's Pre-Delivery and Delivery Check Lists in the Operator's Manual are completed before releasing equipment to the owner.

**The dealer must complete the online Product Registration form at the Woods Dealer Website** which certifies that all Dealer Check List items have been completed. Please contact your dealer to complete this form. Dealers can register all Woods product at dealer.WoodsEquipment.com under Product Registration.

**Failure to register the product does not diminish customer's warranty rights.**

## TO THE OWNER:

Read this manual before operating your Woods equipment. The information presented will prepare you to do a better and safer job. Keep this manual handy for ready reference. Require all operators to read this manual carefully and become acquainted with all adjustment and operating procedures before attempting to operate. Replacement manuals can be obtained from your dealer. To locate your nearest dealer, check the Dealer Locator at [www.WoodsEquipment.com](http://www.WoodsEquipment.com), or in the United States and Canada call 1-800-319-6637.

The equipment you have purchased has been carefully engineered and manufactured to provide dependable and satisfactory use. Like all mechanical products, it will require cleaning and upkeep. Lubricate the unit as specified. Observe all safety information in this manual and safety decals on the equipment.

For service, your authorized Woods dealer has trained mechanics, genuine Woods service parts, and the necessary tools and equipment to handle all your needs.

Use only genuine Woods service parts. Substitute parts will void the warranty and may not meet standards required for safe and satisfactory operation. Record the model number and serial number of your equipment in the spaces provided:

**Model:** \_\_\_\_\_ **Date of Purchase:** \_\_\_\_\_

**Serial Number: (see Safety Decal section for location)** \_\_\_\_\_

Provide this information to your dealer to obtain correct repair parts.

Throughout this manual, the term **NOTICE** is used to indicate that failure to observe can cause damage to equipment. The terms **CAUTION**, **WARNING**, and **DANGER** are used in conjunction with the Safety-Alert Symbol (a triangle with an exclamation mark) to indicate the degree of hazard for items of personal safety.



This is the safety alert symbol. It is used to alert you to potential personal injury hazards. Obey all safety messages that follow this symbol to avoid possible injury or death.



Indicates a hazardous situation which, if not avoided, will result in death or serious injury.



Indicates a hazardous situation which, if not avoided, could result in death or serious injury.



Indicates a hazardous situation which, if not avoided, could result in minor or moderate injury.

**IMPORTANT  
or NOTICE**

Is used to address practices not related to personal injury.

**NOTE**

Indicates helpful information.

**WOODS®**

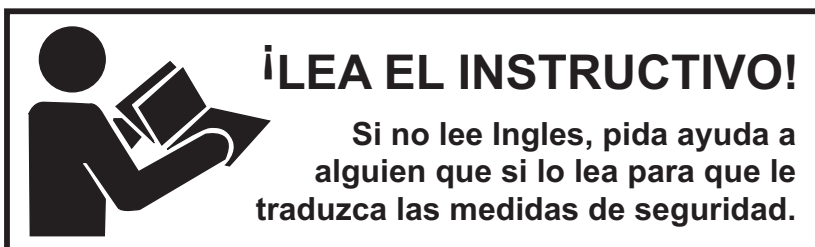
**ALITEC™**  
**BMP®**  
**CENTRAL FABRICATORS®**  
**GANNON®**  
**GILL®**  
**WAIN-ROY®**  
**WOODS®**

## 2 Introduction

Gen'l (Rev. 3/5/2010)

# TABLE OF CONTENTS

INTRODUCTION .....	2
SPECIFICATIONS .....	4
GENERAL INFORMATION .....	4
SAFETY VIDEO ORDER FORM .....	5
SAFETY RULES .....	7
SAFETY DECALS .....	11
OPERATION .....	14
OWNER SERVICE .....	21
TROUBLESHOOTING .....	27
DEALER SERVICE .....	29
ASSEMBLY .....	38
DEALER CHECK LIST .....	48
PARTS LISTS .....	49
BOLT TORQUE CHART .....	77
BOLT SIZE CHART & ABBREVIATIONS .....	78
INDEX .....	79
REPLACEMENT PARTS WARRANTY .....	78
PRODUCT WARRANTY .....	INSIDE BACK COVER



This Operator's Manual should be regarded as part of the machine. Suppliers of both new and second-hand machines must make sure that this manual is provided with the machine.

# SPECIFICATIONS

	TS1680	TS1680Q
Cutting Height Range (varies with tire and wheel selection)	2" to 13"	2" to 13"
Cutting Width	168"	168"
Overall Width	176"	176"
Overall Length (Pull-Type / Mounted)	158" / 123"	158" / 123"
Tractor HP	50-200	50-200
Tractor PTO	540 rpm	1000 rpm
Blade Spindles	3	3
Blade Overlap	4"	4"
Number of Blades	6	6
Center Driveline with Slip Clutch	Cat 5 Heavy / CV - Cat 6	Cat 5 Heavy / CV - Cat 6
Side Frame Thickness	1/4"	1/4"
Weight - Pull-Type (approx. lbs)	3396	3396
Blade Tip Speed (feet per minute)	15,540	15,540
Blade Rotation	Left - CW; Right & Center CCW	Left & Center - CW; Right CCW
Wheel Size	15" Rims or 21" OD Solid Tires, Airplane	
Torsion Protection	Slip Clutch and Flexible Couplers	

## GENERAL INFORMATION

### WARNING

■ Some illustrations in this manual show the equipment with safety shields removed to provide a better view. This equipment should never be operated with any necessary safety shielding removed.

The purpose of this manual is to assist you in operating and maintaining your cutter. Read it carefully. It furnishes information and instructions that will help you achieve years of dependable performance. These instructions have been compiled from extensive field experience and engineering data. Some information may be general in nature, due to unknown and varying operating conditions. However, through experience

and these instructions, you should be able to develop procedures suitable to your particular situation.

The illustrations and data used in this manual were current at the time of printing. However, due to possible inline production changes, your machine may vary slightly in detail. We reserve the right to redesign and change the machines as may be necessary without notification.

Throughout this manual, references are made to right and left directions. These are determined by standing behind the equipment, facing the direction of forward travel. Blade rotation, viewed from the top of the cutter, is counter-clockwise for the right crossbar, and clockwise for the left crossbar; the center crossbar is counter-clockwise on the 540 rpm model and clockwise on the 1000 rpm model.

## 4 Introduction

MAN0577 (6/29/2007)

**BE SAFE!**

**BE ALERT!**

**BE ALIVE!**

**BE TRAINED**

**Before Operating Mowers!**



ASSOCIATION OF  
EQUIPMENT  
MANUFACTURERS

*Safety Training  
Does Make a Difference.*

---

## **Free Mower Safety Video**

Fill out and return the order form and we will send you a FREE VHS or DVD video outlining ***Industrial and Agricultural Mower Safety Practices***. The 22 minute video, developed in cooperation with AEM (Association of Equipment Manufacturers), reinforces the proper procedures to follow while operating your mowing equipment. The video does not replace the information contained in the Operator's Manual, so please review this manual thoroughly before operating your new mowing equipment.

**Also, available from the Association of Equipment Manufacturers:**

A large variety of training materials (ideal for groups) are available for a nominal charge from AEM. Following is a partial list:

- **Training Package for Rotary Mowers/Cutters-English**  
Contains: DVD & VHS (English)  
    Guidebook for Rotary Mowers/Cutters (English)  
    AEM Industrial/Agricultural Mower Safety Manual (English)  
    AEM Agricultural Tractor Safety Manual (English)
  
- **Training Package for Rotary Mowers/Cutters-English/Spanish**  
Contains: DVD & VHS (English/Spanish)  
    Guidebook for Rotary Mowers/Cutters (English/Spanish)  
    AEM Industrial/Agricultural Mower Safety Manual (English/Spanish)  
    AEM Agricultural Tractor Safety Manual (English/Spanish)

AEM training packages are available through:

AEM at: [www.aem.org](http://www.aem.org)

or

Universal Lithographers, Inc.

Email: [aem@ulilitho.com](mailto:aem@ulilitho.com)

800-369-2310 tel

866-541-1668 fax



---

## Free Mower/Cutter Safety Video Order Form

Please send me  (Select one)  
 **VHS** Format - VHS01052 Safety Video  
 **DVD** Format - DVD01052 Safety Video

Name: \_\_\_\_\_ Phone: \_\_\_\_\_

Address: \_\_\_\_\_  
\_\_\_\_\_  
\_\_\_\_\_

Mower/Cutter Model: \_\_\_\_\_ Serial #: \_\_\_\_\_

Send to:     ATTENTION: DEALER SERVICES  
              **WOODS EQUIPMENT COMPANY**  
              PO BOX 1000  
              OREGON IL 61061-1000  
              USA

# SAFETY RULES



**ATTENTION! BECOME ALERT! YOUR SAFETY IS INVOLVED!**



Safety is a primary concern in the design and manufacture of our products. Unfortunately, our efforts to provide safe equipment can be wiped out by an operator's single careless act.

In addition to the design and configuration of equipment, hazard control and accident prevention are dependent upon the awareness, concern, judgement, and proper training of personnel involved in the operation, transport, maintenance, and storage of equipment.

It has been said, "The best safety device is an informed, careful operator." We ask you to be that kind of operator.

## TRAINING

- **Safety instructions are important! Read all attachment and power unit manuals; follow all safety rules and safety decal information. (Replacement manuals and safety decals are available from your dealer. To locate your nearest dealer, check the Dealer Locator at [www.WoodsEquipment.com](http://www.WoodsEquipment.com), or in the United States and Canada call 1-800-319-6637.) Failure to follow instructions or safety rules can result in serious injury or death.**
- **If you do not understand any part of this manual and need assistance, see your dealer.**
- **Know your controls and how to stop engine and attachment quickly in an emergency.**
- **Operators must be instructed in and be capable of the safe operation of the equipment, its attachments, and all controls. Do not allow anyone to operate this equipment without proper instructions.**
- **Keep hands and body away from pressurized lines. Use paper or cardboard, not hands or other body parts to check for leaks. Wear safety goggles. Hydraulic fluid under pressure can easily penetrate skin and will cause serious injury or death.**
- **Make sure that all operating and service personnel know that if hydraulic fluid penetrates skin, it must be surgically removed as soon as possible by a doctor familiar with this form of injury or gangrene, serious injury, or death will result. CONTACT A PHYSICIAN IMMEDIATELY IF FLUID ENTERS SKIN OR EYES. DO NOT DELAY.**
- **Never allow children or untrained persons to operate equipment.**

## PREPARATION

- **Check that all hardware is properly installed. Always tighten to torque chart specifications unless instructed otherwise in this manual.**
- **Air in hydraulic systems can cause erratic operation and allows loads or equipment components to drop unexpectedly. When connecting equipment or hoses or performing any hydraulic maintenance, purge any air in hydraulic system by operating all hydraulic functions several times. Do this before putting into service or allowing anyone to approach the equipment.**
- **Make sure all hydraulic hoses, fittings, and valves are in good condition and not leaking before starting power unit or using equipment. Check and route hoses carefully to prevent damage. Hoses must not be twisted, bent sharply, kinked, frayed, pinched, or come into contact with any moving parts. Operate moveable components through full operational range to check clearances. Replace any damaged hoses immediately.**
- **Always wear relatively tight and belted clothing to avoid getting caught in moving parts. Wear sturdy, rough-soled work shoes and protective equipment for eyes, hair, hands, hearing, and head; and respirator or filter mask where appropriate.**
- **Make sure attachment is properly secured, adjusted, and in good operating condition.**
- **Make sure spring-activated locking pin or collar slides freely and is seated firmly in tractor PTO spline groove.**
- **Make sure driveline guard tether chains are attached to the tractor and equipment as shown in the pamphlet that accompanies the driveline. Replace if damaged or broken. Check that driveline guards rotate freely on driveline before putting equipment into service.**
- **Power unit must be equipped with ROPS or ROPS cab and seat belt. Keep seat belt securely fastened. Falling off power unit can result in death from being run over or crushed. Keep foldable ROPS system in "locked up" position at all times.**
- **Inspect chain shielding before each use. Replace if damaged.**

*(Safety Rules continued on next page)*

# SAFETY RULES



**ATTENTION! BECOME ALERT! YOUR SAFETY IS INVOLVED!**



*(Safety Rules continued from previous page)*

- Remove accumulated debris from this equipment, power unit, and engine to avoid fire hazard.
- Make sure all safety decals are installed. Replace if damaged. (See Safety Decals section for location.)
- Make sure shields and guards are properly installed and in good condition. Replace if damaged.
- Do not put this equipment into service unless all side skids are properly installed and in good condition. Replace if damaged.
- A minimum 20% of tractor and equipment weight must be on the tractor front wheels when attachments are in transport position. Without this weight, tractor could tip over, causing personal injury or death. The weight may be attained with front wheel weights, ballast in tires or front tractor weights. Weigh the tractor and equipment. Do not estimate.
- Inspect and clear area of stones, branches, or other hard objects that might be thrown, causing injury or damage.

## OPERATION

- Full chain shielding must be installed when operating in populated areas or other areas where thrown objects could injure people or damage property.
  - If this machine is not equipped with full chain shielding, operation must be stopped when anyone comes within 300 feet (92 m).
  - This shielding is designed to reduce the risk of thrown objects. The mower deck and protective devices cannot prevent all objects from escaping the blade enclosure in every mowing condition. It is possible for objects to ricochet and escape, traveling as much as 300 feet (92 m).
- Do not allow bystanders in the area when operating, attaching, removing, assembling, or servicing equipment.
- Never direct discharge toward people, animals, or property.
- Do not operate or transport equipment while under the influence of alcohol or drugs.
- Operate only in daylight or good artificial light.
- Keep hands, feet, hair, and clothing away from equipment while engine is running. Stay clear of all moving parts.

- Always comply with all state and local lighting and marking requirements.
- Never allow riders on power unit or attachment.
- Power unit must be equipped with ROPS or ROPS cab and seat belt. Keep seat belt securely fastened. Falling off power unit can result in death from being run over or crushed. Keep foldable ROPS system in “locked up” position at all times.
- Always sit in power unit seat when operating controls or starting engine. Securely fasten seat belt, place transmission in neutral, engage brake, and ensure all other controls are disengaged before starting power unit engine.
- Connect PTO driveline directly to power unit PTO shaft. Never use adapter sleeves or adapter shafts. Adapters can cause driveline failures due to incorrect spline or incorrect operating length and can result in personal injury or death.
- Operate tractor PTO at 540 RPM (1000 RPM on Q Series cutters). Do not exceed.
- Look down and to the rear and make sure area is clear before operating in reverse.
- Do not operate or transport on steep slopes.
- Do not stop, start, or change directions suddenly on slopes.
- Use extreme care and reduce ground speed on slopes and rough terrain.
- Watch for hidden hazards on the terrain during operation.
- Stop power unit and equipment immediately upon striking an obstruction. Turn off engine, remove key, inspect, and repair any damage before resuming operation.
- Leak down or failure of mechanical or hydraulic system can cause equipment to drop.
- On pull-type units with optional hydraulic cutting height adjustment, use a single-acting cylinder with a maximum extended length of 28-1/4" (718 mm) from attaching point center to center.
- On mounted units with optional hydraulic cutting height adjustment, use a double-acting cylinder with a maximum extended length of 28-1/4" (718 mm) from attaching point center to center.

## TRANSPORTATION

- The maximum transport speed for towed and semi-mounted machines is 20 mph (32 km/h). Regardless of the maximum speed capability of the





# SAFETY RULES

**ATTENTION! BECOME ALERT! YOUR SAFETY IS INVOLVED!**



towing tractor, do not exceed the implement's maximum transport speed. Doing so could result in:

- Loss of control of the implement and tractor
  - Reduced or no ability to stop during braking
  - Implement tire failure
  - Damage to the implement or its components.
- Use additional caution and reduce speed when under adverse surface conditions, turning, or on inclines.
  - Never tow this implement with a motor vehicle.
  - Do not operate PTO during transport.
  - Do not operate or transport on steep slopes.
  - Do not operate or transport equipment while under the influence of alcohol or drugs.
  - Always comply with all state and local lighting and marking requirements.
  - Never allow riders on power unit or attachment.

## MAINTENANCE

- Before dismounting power unit or performing any service or maintenance, follow these steps: disengage power to equipment, lower the 3-point hitch and all raised components to the ground, operate valve levers to release any hydraulic pressure, set parking brake, stop engine, remove key, and unfasten seat belt.
- Before performing any service or maintenance, disconnect driveline from tractor PTO.
- Before working underneath, raise mower, install transport lock, and block mower securely. Hydraulic system leak down and failure of mechanical or hydraulic system can cause equipment to drop.
- Do not modify or alter or permit anyone else to modify or alter the equipment or any of its components in any way.
- Your dealer can supply original equipment hydraulic accessories and repair parts. Substitute parts may not meet original equipment specifications and may be dangerous.
- Always wear relatively tight and belted clothing to avoid getting caught in moving parts. Wear sturdy, rough-soled work shoes and protective equipment for eyes, hair, hands, hearing, and head; and respirator or filter mask where appropriate.
- Do not allow bystanders in the area when operating, attaching, removing, assembling, or servicing equipment.

- Never go underneath equipment (lowered to the ground or raised) unless it is properly blocked and secured. Never place any part of the body underneath equipment or between moveable parts even when the engine has been turned off. Hydraulic system leak down, hydraulic system failures, mechanical failures, or movement of control levers can cause equipment to drop or rotate unexpectedly and cause severe injury or death. Follow Operator's Manual instructions for working underneath and blocking requirements or have work done by a qualified dealer.

- Make sure attachment is properly secured, adjusted, and in good operating condition.

- Keep all persons away from operator control area while performing adjustments, service, or maintenance.

- Make certain all movement of equipment components has stopped before approaching for service.

- Frequently check blades. They should be sharp, free of nicks and cracks, and securely fastened.

- Do not handle blades with bare hands. Careless or improper handling may result in serious injury.

- Your dealer can supply genuine replacement blades. Substitute blades may not meet original equipment specifications and may be dangerous.

- Tighten all bolts, nuts, and screws to torque chart specifications. Check that all cotter pins are installed securely to ensure equipment is in a safe condition before putting unit into service.

- Make sure all safety decals are installed. Replace if damaged. (See Safety Decals section for location.)

- Make sure shields and guards are properly installed and in good condition. Replace if damaged.

- Do not disconnect hydraulic lines until machine is securely blocked or placed in lowest position and system pressure is released by operating valve levers.

- Leak down or failure of mechanical or hydraulic system can cause equipment to drop.

*(Safety Rules continued on next page)*

# SAFETY RULES



**ATTENTION! BECOME ALERT! YOUR SAFETY IS INVOLVED!**



*(Safety Rules continued from previous page)*

## **STORAGE**

■ Keep children and bystanders away from storage area.

■ Follow manual instructions for storage.

### **ON MOUNTED CUTTERS:**

■ Disconnect cutter driveshaft and secure up off ground. Raise cutter with 3-point hitch. Place

blocks under cutter side skids. Lower cutter onto blocks. Disconnect hydraulic lines to optional cylinder. Disconnect cutter from tractor 3-point hitch and carefully drive tractor away from cutter.

### **ON PULL-TYPE CUTTERS:**

■ Raise cutter and block securely. Block wheels and raise tongue with jack. Disconnect hydraulic lines to optional cylinder. Disconnect driveline and secure up off the ground.



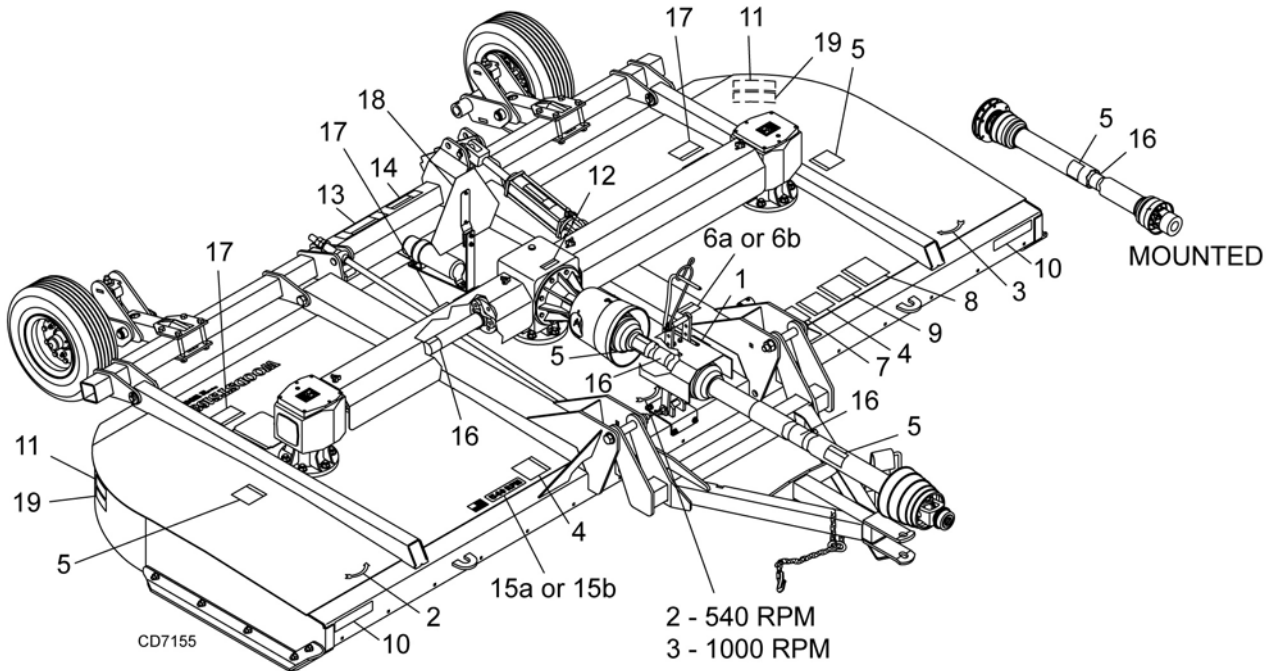
# SAFETY & INSTRUCTIONAL DECALS



**ATTENTION! BECOME ALERT! YOUR SAFETY IS INVOLVED!**



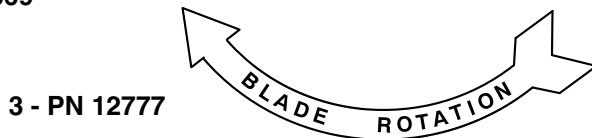
**Replace Immediately If Damaged!**



## 1 - SERIAL NUMBER PLATE



## 2 - PN 5669



## 3 - PN 12777

## 4 - PN 1003751

<b>WARNING</b>			
<b>CRUSHING AND PINCHING HAZARD</b>			
<ul style="list-style-type: none"> <li>■ Be extremely careful handling various parts of the machine. They are heavy and hands, fingers, feet, and other body parts could be crushed or pinched between tractor and implement.</li> <li>■ Operate tractor controls from tractor seat only.</li> <li>■ Do not stand between tractor and implement when tractor is in gear.</li> <li>■ Make sure parking brake is engaged before going between tractor and implement.</li> <li>■ Stand clear of machine while in operation or when it is being raised or lowered.</li> </ul>			
<p><b>FAILURE TO FOLLOW THESE INSTRUCTIONS COULD RESULT IN SERIOUS INJURY OR DEATH.</b></p>			
			1003751-A

## BE CAREFUL!

Use a clean, damp cloth to clean safety decals.

Avoid spraying too close to decals when using a pressure washer; high-pressure water can enter through very small scratches or under edges of decals causing them to peel or come off.

Replacement safety decals can be ordered free from your Woods dealer. To locate your nearest dealer, check the Dealer Locator at [www.WoodsEquipment.com](http://www.WoodsEquipment.com), or in the United States and Canada call 1-800-319-6637.

*(Safety Decals continued on next page)*

# SAFETY & INSTRUCTIONAL DECALS



**ATTENTION! BECOME ALERT! YOUR SAFETY IS INVOLVED!**



**Replace Immediately If Damaged!**

(Safety Decals continued from previous page)

5 - PN 18864

8 - PN 18865

<b>DANGER</b>
<p><b>ROTATING DRIVELINE CONTACT CAN CAUSE DEATH KEEP AWAY!</b></p> <p><b>DO NOT OPERATE WITHOUT -</b></p> <ul style="list-style-type: none"> <li>■ All driveline guards, tractor and equipment shields in place</li> <li>■ Drivelines securely attached at both ends</li> <li>■ Driveline guards that turn freely on driveline</li> </ul>
<small>18864-C</small>

<b>WARNING</b>	
<p><b>FALLING OFF CAN RESULT IN BEING RUN OVER.</b></p> <ul style="list-style-type: none"> <li>■ Tractor must be equipped with ROPS (or ROPS CAB) and seat belt. Keep foldable ROPS systems in "locked up" position at all times.</li> <li>■ Buckle Up! Keep seat belt securely fastened.</li> <li>■ Allow no riders.</li> </ul> <p><b>RAISED EQUIPMENT CAN DROP AND CRUSH.</b></p> <ul style="list-style-type: none"> <li>■ Before working underneath, follow all instructions and safety rules in operator's manual and securely block up all corners of equipment with jack stands.</li> <li>■ Securely blocking prevents equipment dropping from hydraulic leak-down, hydraulic system failures or mechanical component failures.</li> </ul> <p><b>FALLING OFF OR FAILING TO BLOCK SECURELY CAN RESULT IN SERIOUS INJURY OR DEATH.</b></p>	
<small>18865-C</small>	

<b>WARNING</b>
<p><b>DO NOT EXCEED PTO SPEED OF 540 RPM</b></p> <p>PTO speeds higher than 540 RPM can cause equipment failure and personal injury.</p>
<small>18866-D</small>

6a - PN 18866  
540 RPM

-OR-

6b - PN 15922  
1000 RPM

<b>WARNING</b>
<p><b>DO NOT EXCEED PTO SPEED OF 1000 RPM</b></p> <p>PTO speeds higher than 1000 RPM can cause equipment failure and personal injury.</p>
<small>15922-C</small>

7 - PN 18877

9 - PN 15503

<b>WARNING</b>
<p><b>TO AVOID SERIOUS INJURY OR DEATH:</b></p> <ul style="list-style-type: none"> <li>■ Read Operator's Manual (available from dealer) and follow all safety precautions.</li> <li>■ Keep all shields in place and in good condition.</li> <li>■ Operate mower from tractor seat only.</li> <li>■ Lower mower, stop engine and remove key before dismounting tractor.</li> <li>■ Allow no children or untrained persons to operate equipment.</li> <li>■ Do not transport towed or semi-mounted units over 20 mph.</li> </ul> <p><b>FAILURE TO OPERATE SAFELY CAN RESULT IN INJURY OR DEATH.</b></p>
<small>18877-C</small>

<b>DANGER</b>		
<p><b>ROTATING BLADES AND THROWN OBJECTS</b></p> <ul style="list-style-type: none"> <li>■ Do not put hands or feet under or into mower when engine is running.</li> <li>■ Before mowing, clear area of objects that may be thrown by blade.</li> <li>■ Keep bystanders away.</li> <li>■ Keep guards in place and in good condition.</li> </ul> <p><b>BLADE CONTACT OR THROWN OBJECTS CAN CAUSE SERIOUS INJURY OR DEATH.</b></p>		
<small>15503-C</small>		

# SAFETY & INSTRUCTIONAL DECALS

**⚠ ATTENTION! BECOME ALERT! YOUR SAFETY IS INVOLVED! ⚠**  
**Replace Immediately If Damaged!**

- 10 - PN 1002940 AMBER FRONT REFLECTOR 9"
- 11 - PN 57123 RED REAR REFLECTOR 9"
- 19 - PN 20034034 RED / ORANGE FLUORESCENT 2" X 9"

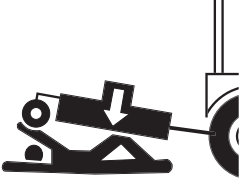
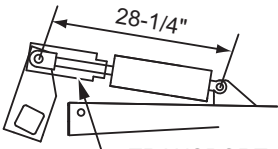
12 - PN 1004114

**⚠ DANGER**


If shaft connection is visible, shield is missing. Replace shield before operating equipment.

1004114

13 - PN 1004991

 <p style="font-size: x-small; text-align: center;">1004991</p>	<p><b>⚠ WARNING</b></p> <p><b>RAISED CUTTER CAN DROP AND CRUSH</b></p> <ul style="list-style-type: none"> <li>■ Cutters must be equipped with transport lock.</li> <li>■ Before working underneath, transport lock must be in the raised position. All corners of cutter must be securely blocked with jack stands.</li> <li>■ All transport components must be functional, kept in good condition, and stored on equipment.</li> <li>■ Blocking up prevents cutter dropping from hydraulic leak down, hydraulic system failures, or mechanical component failures.</li> </ul> <p style="text-align: center; font-weight: bold;">FAILURE TO FOLLOW INSTRUCTIONS CAN RESULT IN SERIOUS INJURY OR DEATH.</p>	<p><b>TRANSPORT LOCK AND CYLINDER REQUIREMENTS</b></p> <p>SINGLE-ACTING FULL EXTENSION</p>  <p style="text-align: center;">TRANSPORT LOCK</p>
--	--	--

14 - PN 19924

 <p style="font-size: x-small; text-align: center;">19924-B</p>	<p><b>⚠ WARNING</b></p> <p><b>HIGH-PRESSURE HYDRAULIC OIL LEAKS CAN PENETRATE SKIN RESULTING IN SERIOUS INJURY, GANGRENE OR DEATH.</b></p> <ul style="list-style-type: none"> <li>■ Check for leaks with cardboard; never use hand.</li> <li>■ Before loosening fittings: lower load, release pressure, and be sure oil is cool.</li> <li>■ Consult physician immediately if skin penetration occurs.</li> </ul>
--	--

16 - PN 33347

**⚠ DANGER**



GUARD MISSING. DO NOT OPERATE.

**⚠ DANGER**



GUARD MISSING. DO NOT OPERATE.

33347E

**⚠ DANGER**

540 RPM

57840

15a - PN 57840  
540 RPM

1000 RPM

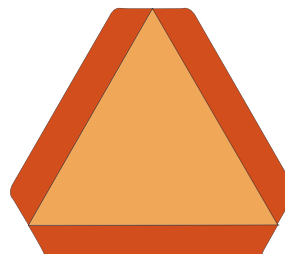
57841

-OR-

15b - PN 57841  
1000 RPM

17 - PN 15502

<p><b>⚠ WARNING</b></p>
<p><b>ROTATING COMPONENTS</b></p>
<p>Do not operate without cover in place. Look and listen for rotation. Do not open cover until all components have stopped.</p>
<p><b>CONTACT WITH ROTATING PARTS CAN CAUSE SERIOUS INJURY.</b></p>
<p>15502-B</p>



18 - PN 24611  
SLOW MOVING  
VEHICLE EMBLEM

# OPERATION

The operator is responsible for the safe operation of the cutter. The operator must be properly trained. Operators should be familiar with the cutter, the tractor, and all safety practices before starting operation. Read the safety rules and safety decals on pages 7 to 13.

This heavy-duty cutter is designed for grass and weed mowing and shredding.

Recommended mowing speed for most conditions is from 2 to 5 mph.

## **! DANGER**

■ Full chain shielding must be installed when operating in populated areas or other areas where thrown objects could injure people or damage property.

- If this machine is not equipped with full chain shielding, operation must be stopped when anyone comes within 300 feet (92 m).
- This shielding is designed to reduce the risk of thrown objects. The mower deck and protective devices cannot prevent all objects from escaping the blade enclosure in every mowing condition. It is possible for objects to ricochet and escape, traveling as much as 300 feet (92 m).

## **! WARNING**

- Never allow riders on power unit or attachment.
- Make sure spring-activated locking pin or collar slides freely and is seated firmly in tractor PTO spline groove.
- Operate tractor PTO at 540 RPM (1000 RPM on Q Series cutters). Do not exceed.
- Do not allow bystanders in the area when operating, attaching, removing, assembling, or servicing equipment.
- Stop power unit and equipment immediately upon striking an obstruction. Turn off engine, remove key, inspect, and repair any damage before resuming operation.

## **! CAUTION**

- Always wear relatively tight and belted clothing to avoid getting caught in moving parts. Wear sturdy, rough-soled work shoes and protective equipment for eyes, hair, hands, hearing, and head; and respirator or filter mask where appropriate.
- Safety tow chain must be hooked-up to both the implement and tractor during operation or trans-

port. A loose, dragging chain could be struck by the blades causing serious injury.

## **TRACTOR STABILITY**

### **! WARNING**

■ A minimum 20% of tractor and equipment weight must be on the tractor front wheels when attachments are in transport position. Without this weight, tractor could tip over, causing personal injury or death. The weight may be attained with front wheel weights, ballast in tires or front tractor weights. Weigh the tractor and equipment. Do not estimate.

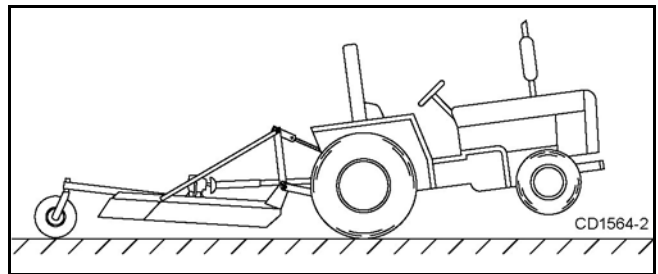


Figure 1. Tractor Stability

## **CONNECT CUTTER TO TRACTOR (PULL-TYPE)**

### **NOTICE**

■ For tractors with a 1-3/8" diameter PTO shaft, the horizontal distance from end of tractor PTO shaft to center of drawbar pin should be 14" for the 540 rpm cutter and 16" for the 1000 rpm cutter. Tractors with a 1-3/4" 20-spline PTO shaft should be set to 20". This will minimize joint knock and damage to drive components.

1. Adjust tractor drawbar to obtain the desired drawbar-to-hitch-point distance.

**NOTE:** On some tractors, a drawbar kit must be used to obtain the required dimension. Check with your tractor dealer for assistance.

2. Attach parking jack to cutter tongue. Raise tongue to tractor drawbar height.
3. Secure cutter to tractor drawbar with a high-strength drawbar pin 3/4" or larger. Keep pin in place during operation.
4. Loop safety tow chain around tractor drawbar support. Secure the hook to a chain link that allows enough slack for proper hitch articulation.
5. Connect cutter driveline to tractor PTO shaft, making sure the spring-activated lock pin slides freely and is seated in tractor PTO splined groove.

- Remove parking jack from the tongue and attach it to the storage post on the front of the cutter.
- Adjust H-frame bearing height so that the front driveline is parallel to the ground. Secure with 1/2 x 5-3/4 clevis pin and 3/16 x 1 cotter pin.
- Attach drive shaft shield to bearing housing using two 3/8 x 1 cap screws and 3/8 lock washers.

## Hydraulic Connection

- Inspect hydraulic hoses to ensure they are in good condition.
- Clean the fittings before connecting them to the tractor hydraulic ports.
- Attach the hydraulic hose from the cutter to the tractor.
- Route the hose through the hose holder on H-frame and be sure the hose can slide freely in the holder. Do not allow hose slack to drag on the ground or become caught on tractor protrusions.
- From the operator position, start tractor and raise and lower deck several times to purge trapped air from the hydraulic cylinder.

## Interference Check

- Be sure that tractor 3-point lift links do not interfere with hydraulic hoses, cutter driveline, or cutter frame.
- Check for straight-ahead operation and at full-turning angles. If there is any interference, remove the lower lift links.
- Contact between tractor lift links and cutter parts can cause damage, especially when turning.

## Turning Limits for CV Driveline

You must not exceed a turning angle of 80 degrees at the head of the Constant Velocity driveline or damage will occur.

To check for potential excessive turn angle:

- Disconnect driveline from tractor, start engine and turn as far right or left as possible.
- Shut engine off, set parking brake, remove key, and try to connect CV driveline to tractor. If it cannot be connected, the angle is too severe.
- Restart engine and straighten angle slightly. Repeat step 2 until driveline can be connected. The point at which the driveline can be connected is the maximum turn that should be made.

## **CONNECT CUTTER TO TRACTOR (MOUNTED)**

### Tractor Adjustments

Before attaching tractor to cutter, install sway blocks or sway chains, or adjust stabilizer bars. Refer to the tractor operator's manual for instructions.

Install tractor front end weights as recommended by the tractor manufacturer to provide 20% of weight on front wheels.

### **⚠ WARNING**

■ A minimum 20% of tractor and equipment weight must be on the tractor front wheels when attachments are in transport position. Without this weight, tractor could tip over, causing personal injury or death. The weight may be attained with front wheel weights, ballast in tires or front tractor weights. Weigh the tractor and equipment. Do not estimate.

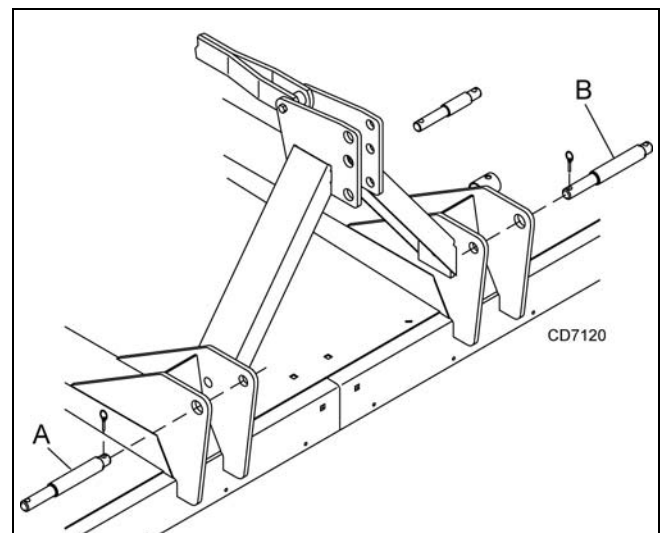


Figure 2. 3-Point Mounting Positions

### Category 2 Standard Hitch

- Position tractor lower lift arms between hitch mast plates.
- Insert lower hitch pins to Position B, Figure 2, through mast plates and tractor lower lift arms.
- Secure with lynch pins.
- Attach top link for mounted units in the middle hole of upper mast using top link pin.

### Category 3 Standard Hitch

- Position tractor lower lift arms between hitch mast plates.

2. Insert lower hitch pins to Position A, Figure 2, through mast plates and tractor lower lift arms.
3. Secure with lynch pins.
4. Attach top link for mounted units in the top hole of upper mast using top link pin.

### Category 2 & 3 Quick Hitches

1. Position lower hitch pins to Position A, Figure 2.
2. Use the upper hole that matches upper quick hitch point location. This is usually the lower hole for Category 2 and the middle hole for Category 3.
3. Secure with lynch pins.
4. Attach tractor to cutter and secure hitch according to hitch manufacturer's instructions.

### DRIVELINE ADJUSTMENT (MOUNTED)

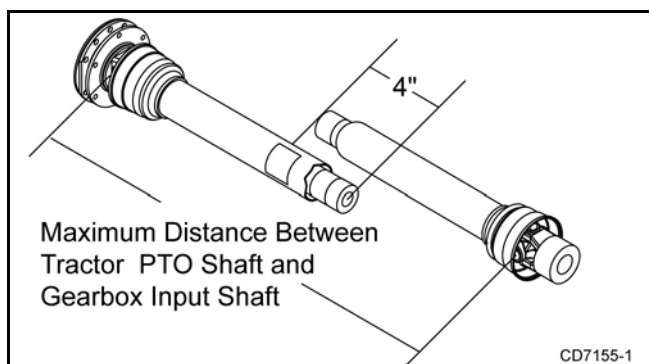
Attach the cutter to the tractor 3-point hitch (or quick hitch if available). Do not attach driveline at this time.

#### **NOTICE**

■ If attaching cutter using a Quick Hitch the distance between the tractor PTO and the gearbox input shaft will increase. Follow steps as you would for the 3-point hitch to insure proper engagement.

Raise and lower cutter and measure the maximum and minimum distance between the tractor PTO shaft and the gearbox input shaft. Separate the driveline into two halves and lay them side-by-side with U-joints at opposite ends.

Set the two U-joints at the maximum distance measures (this is the cutters lowest point of operation) and check the amount of overlap between the two drive halves. There must be at least 4 inches of overlap. If the driveline is too short (less than 4" overlap), contact your Woods dealer for a longer drive.



**Figure 3. 4 Inch Minimum Overlap**

Set the two U-joints to the minimum distance measured (this is the cutter's highest point) and check to see if the driveline bottoms out. If driveline is too long, follow the instructions to shorten the drive.

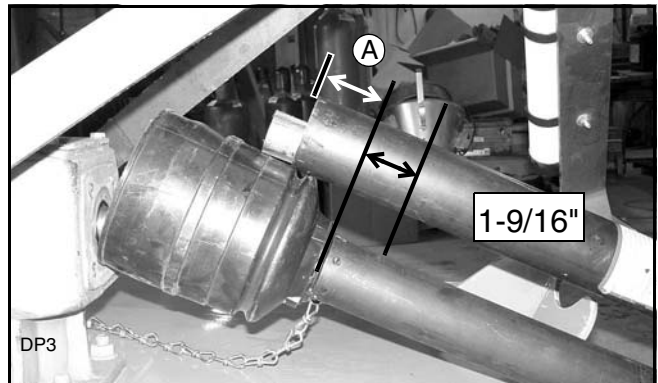
### Shorten Driveline

1. Separate driveline into two halves and connect them to the tractor PTO and gearbox input shaft.
2. Place the two halves parallel to one another to determine how much the driveline must be shortened. See Figure 4 for example.



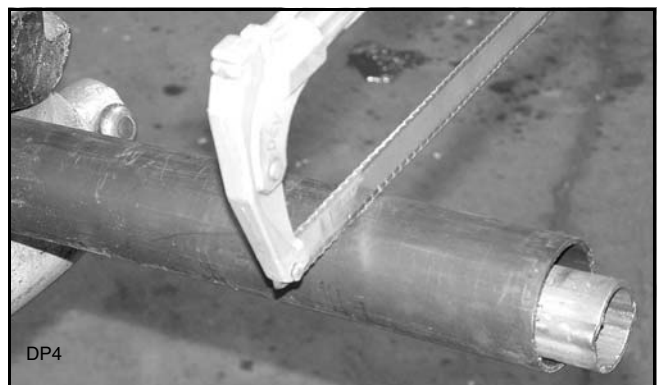
**Figure 4. Drive Halves Placed Parallel**

3. Measure from the end of the upper shield to the base of the bell on the lower shield (A). Add 1-9/16" to dimension (A). See Figure 5.



**Figure 5. Determine Shield Length**

4. Cut the shield to the overall dimension (Figure 6).



**Figure 6. Cut Shield**



5. Place the cutoff portion of the shield against the end of the shaft and use it as a guide. Mark and cut the shaft. See Figure 7.
6. Repeat step 5 for other half of drive.
7. File and clean ends of both drive halves.



Figure 7. Cut Shaft to Length

### Driveline Interference Check

1. Check for clearance between driveline and cutter deck.
2. With driveline properly attached to tractor and gearbox, slowly lift cutter and observe driveline. If clearance between driveline and cutter deck is less than 1 inch, shorten top link or limit upper travel of lower hitch arms. Refer to tractor operator's manual for instructions.

## CUTTING HEIGHT ADJUSTMENT

### Mounted Units

To adjust cutter for normal mowing, select a cutting height (example: 4 inches). Blades are approximately 1-3/4" above bottom of cutter. Dimension A plus 1-3/4" equals the cutting height.

Adjust the tractor 3-point hitch to a distance of 2-1/4" at position A to obtain a 4" cutting height. See Figure 8.

Using any of the optional height adjustment devices, raise or lower the tailwheel to obtain 2-1/2 to 2-3/4 inches at position B.

Adjust top link to provide 1-1/4 inches of clearance between the break link (2) and the rear of the lift links. See Figure 8. This clearance will allow the cutter to float over uneven terrain.

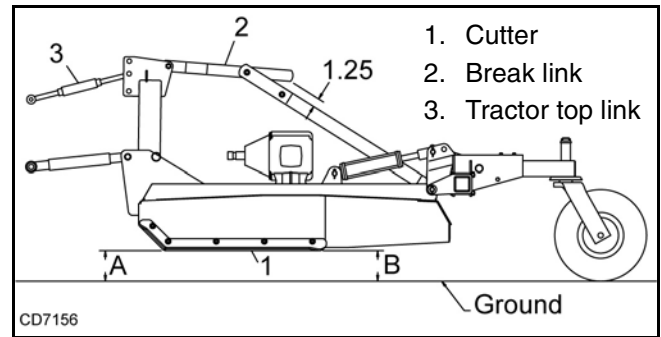


Figure 8. Cutting Height Adjustment

### Pull-Type Units

#### **! WARNING**

- On pull-type units with optional hydraulic cutting height adjustment, use a single-acting cylinder with a maximum extended length of 28-1/4" (718 mm) from attaching point center to center.

Cutting height range is from 2" to 13". A hydraulic cylinder or ratchet jack is available for cutting height adjustment.

When selecting a cutting height, you should consider the area of operation. If the ground is rolling and has mounds the blades could contact, set the cutting height accordingly.

#### **NOTICE**

- Avoid ground contact with blades. Striking ground with blades produces one of the most damaging shock loads a cutter can encounter. If this occurs repeatedly, the cutter, driveline, and gearboxes will be damaged.

To adjust cutter for normal mowing, select a cutting height (example: 4 inches). Blades are approximately 1-3/4" above bottom of cutter. Dimension A plus 1-3/4" equals the cutting height.

Using any of the optional cutting height mechanisms, raise or lower the tailwheel and set dimension A to 2-1/4" to achieve a 4" cutting height.

Loosen the jam nut on the attitude rod that runs from the tongue to the tailwheel. Adjust rod in or out until dimension B is approximately 1/2 inch more than dimension A. Refer to Figure 8.

## **ATTITUDE ADJUSTMENT (PULL-TYPE)**

### **Normal Mowing**

For the most economical power use and best cutting results, the cutter should be from 1/2" to 3/4" higher at the rear than at the front.

For grass and weed mowing, adjust cutter to run level or with the front slightly lower.

### **Shredding**

For shredding, it is better to set rear of cutter slightly lower than the front. How much lower depends on the material to be shredded. Determine the best setting for your situation by experimenting. Use a slow ground speed for better shredding.

## **DRIVELINE ADJUSTMENT (PULL-TYPE)**

With the cutting height established, adjust the driveline carrier bearings in the H-frames so that the front driveline is parallel to the ground with cutter in cutting position.

## **WHEEL SPACING**

Wheels may be adjusted to any position for row crop shredding.

## **BLADE SELECTION**

Optional stump jumpers are recommended for rugged terrain where hidden rocks, stumps, and other objects may be encountered.

There are two blade options available for this cutter: standard suction blades and flat-double edge blades. The standard suction blade is a general use, multipurpose blade. The double-edge blade requires less horse power because it does not mulch or recut material. It is designed for use in areas where blade wear is a problem. Sandy soils are extremely hard on blades.

Blade rotation, viewed from the top of the cutter is counter-clockwise for the right crossbar, and clockwise for the left crossbar; the center crossbar is counter-clockwise on the 540 rpm models and clockwise on the 1000 rpm models.

When one cutting surface of the double-edge blade is worn, the opposite edge may be used by placing the blade on a crossbar of the opposite rotation. Blades from the right may be used on the left. Blades on the left may be used on the right.

**NOTE:** Blades must be moved in pairs. Never use one new blade and one used blade on a crossbar. Crossbar can become unbalanced.

## **TRACTOR OPERATION**

Use care when operating around tree limbs and other low objects.

Use care and reduce ground speed on rough terrain. Always watch for hidden hazards.

Being knocked off or falling off tractor can result in serious injury or death.

Only use a tractor with a Roll Over Protective Structure (ROPS) and seat belt. Securely fasten seat belt before starting tractor.

The cutter is operated with tractor controls. Engage the PTO at a low rpm to prevent excessive loads on the cutter drive system. Increase throttle to proper PTO speed 540 rpm (1000 rpm on "Q" models).

Be sure operator is familiar with all controls and can stop tractor and cutter quickly in an emergency. The operator should give complete, undivided attention to operating tractor and cutter.

## **OPERATING TECHNIQUE**

Power for operating the cutter is supplied by the tractor PTO. Operate PTO at 540 rpm (1000 rpm on "Q" models). Know how to stop the tractor and cutter quickly in an emergency.

Engage PTO at a low engine rpm to minimize stress on the drive system and gearbox. With PTO engaged, raise PTO speed to 540 rpm (1000 rpm on "Q" models) and maintain throughout cutting operation.

Gearbox protection is provided by a slip clutch with replacement fiber disc. The slip clutch is designed to slip when excessive torsional loads occur.

Move slowly into material. Adjust tractor ground speed to provide a clean cut without lugging the tractor engine. Use a slow ground speed for better shredding.

Proper ground speed will depend on the terrain and the material's height, type, and density.

Normally, ground speed will range from 2 to 5 mph. Tall, dense material should be cut at a low speed; thin, medium-height material can be cut at a faster ground speed.

Always operate tractor PTO at proper rpm (540 or 1000) to maintain blade speed and to produce a clean cut.

Under certain conditions tractor tires may roll down some grass and prevent cutting at the same height as the surrounding area. When this occurs, reduce your ground speed but maintain PTO at 540 rpm (1000 rpm on "Q" models). The lower ground speed will permit grass to rebound partially.

## Cutter Operation

When beginning operation of the cutter, make sure that all persons are in a safe location. Slowly move into the material with the tractor PTO set at 540 or 1000 rpm.

## Mowing Tips

### WARNING

- Look down and to the rear and make sure area is clear before operating in reverse.
- Do not operate or transport on steep slopes.
- Do not stop, start, or change directions suddenly on slopes.
- Use extreme care and reduce ground speed on slopes and rough terrain.
- Watch for hidden hazards on the terrain during operation.

### CAUTION

- Stop power unit and equipment immediately upon striking an obstruction. Turn off engine, remove key, inspect, and repair any damage before resuming operation.

Maximum recommended ground speed for cutting or shredding is 5 miles per hour. Adjust tractor ground speed by using higher or lower gears to provide a clean cut without lugging tractor engine.

Tall material should be cut twice. Cut material higher the first pass. Cut at desired height at 90 degrees the second pass.

Remember, sharp blades produce cleaner cuts and use less power.

Before entering an area, analyze it to determine the best procedure. Consider the height and type of material to be cut and the terrain type (hilly, level or rough, etc.).

## TRANSPORTING

### WARNING

- The maximum transport speed for towed and semi-mounted machines is 20 mph (32 km/h). Regardless of the maximum speed capability of the towing tractor, do not exceed the implement's maximum

transport speed. Doing so could result in:

- Loss of control of the implement and tractor
- Reduced or no ability to stop during braking
- Implement tire failure
- Damage to the implement or its components.

■ Use additional caution and reduce speed when under adverse surface conditions, turning, or on inclines.

■ Never tow this implement with a motor vehicle.

1. Always transport with cutter in raised, locked position.
2. Raise cutter with hydraulic cylinder.
3. Rotate transport lock over cylinder rod.
4. Lower cylinder against transport lock.
5. To lower cutter for operation, extend hydraulic cylinder. Rotate transport lock back away from cylinder rod. Lower to desired cutting height.

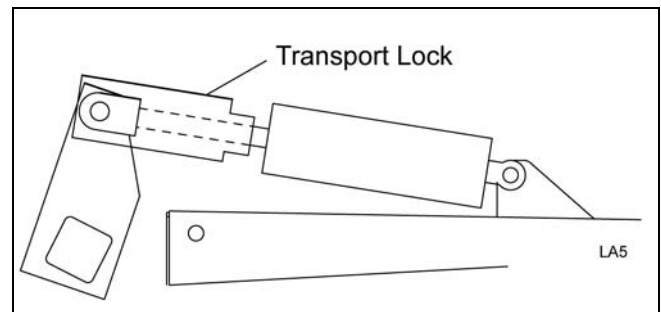


Figure 9. Transport Lock Operation

## STORAGE

### WARNING

- Keep children and bystanders away from storage area.

ON MOUNTED CUTTERS:

- Disconnect cutter driveshaft and secure up off ground. Raise cutter with 3-point hitch. Place blocks under cutter side skids. Lower cutter onto blocks. Disconnect hydraulic lines to optional cylinder. Disconnect cutter from tractor 3-point hitch and carefully drive tractor away from cutter.

ON PULL-TYPE CUTTERS:

- Raise cutter and block securely. Block wheels and raise tongue with jack. Disconnect hydraulic lines to optional cylinder. Disconnect driveline and secure up off the ground.

## **PRE-OPERATION CHECK LIST**

### **(OWNER'S RESPONSIBILITY)**

- \_\_\_ Review and follow all safety rules and safety decal instructions on pages 7 through 13.
- \_\_\_ Check that all safety decals are installed and in good condition. Replace if damaged.
- \_\_\_ Check that equipment is properly and securely attached to tractor.
- \_\_\_ Make sure driveline spring-activated locking pin or collar slides freely and is seated firmly in tractor PTO spline groove.
- \_\_\_ Set tractor PTO at correct rpm for your equipment.
- \_\_\_ Lubricate all grease fitting locations. Make sure PTO shaft slip joint is lubricated.
- \_\_\_ Check that all hydraulic hoses and fittings are in good condition and not leaking before starting tractor. Check that hoses are not twisted, bent sharply, kinked, frayed, or pulled tight. Replace any damaged hoses immediately.
- \_\_\_ Raise and lower equipment to make sure air is purged from hydraulic cylinders and hoses.
- \_\_\_ Check that all hardware is properly installed and secured.
- \_\_\_ Check to ensure blades are sharp, in good condition, and installed correctly. Replace if damaged.
- \_\_\_ Make sure tractor ROPS or ROPS cab and seat belt are in good condition. Keep seat belt securely fastened during operation.
- \_\_\_ Check that shields and guards are properly installed and in good condition. Replace if damaged.
- \_\_\_ Check cutting height, front-to-rear attitude, and top link adjustment.
- \_\_\_ Before starting engine, operator must be in tractor seat with seat belt fastened. Place transmission in neutral or park, engage brake and disengage tractor PTO.
- \_\_\_ Inspect area to be cut and remove stones, branches, or other hard objects that might be thrown and cause injury or damage.
- \_\_\_ Check that chain shielding is in good condition and replace any damaged parts.
- \_\_\_ Make sure tractor 3-point lift links do not interfere with hydraulic hoses or driveline throughout full turning range.



# OWNER SERVICE

The information in this section is written for operators who possess basic mechanical skills. If you need help, your dealer has trained service technicians available. For your protection, read and follow the safety information in this manual.

## WARNING

■ **Keep all persons away from operator control area while performing adjustments, service, or maintenance.**

## CAUTION

■ **If you do not understand any part of this manual and need assistance, see your dealer.**

■ **Always wear relatively tight and belted clothing to avoid entanglement in moving parts. Wear sturdy, rough-soled work shoes and protective equipment for eyes, hair, hands, hearing, and head; and respirator or filter mask where appropriate.**

## BLOCKING METHOD

## WARNING

■ **Never go underneath equipment (lowered to the ground or raised) unless it is properly blocked and secured. Never place any part of the body underneath equipment or between moveable parts even when the engine has been turned off. Hydraulic system leak down, hydraulic system failures, mechanical failures, or movement of control levers can cause equipment to drop or rotate unexpectedly and cause severe injury or death. Follow Operator's Manual instructions for working underneath and blocking requirements or have work done by a qualified dealer.**

To minimize the potential hazards of working underneath the cutter, follow these procedures.

1. Jackstands with a load rating of 1000 lbs or more are the only approved blocking device for this cutter. Install a minimum of four jackstands (shown by Xs in Figure 10) under the cutter before working underneath unit.

Do not position jackstands under wheels, axles, or wheel supports. Components can rotate and cause cutter to fall.

2. Consider the overall stability of the blocked unit. Just placing jackstands underneath will not ensure your safety.

The working surface must be level and solid to support the weight on the jackstands. Make sure jackstands are stable, both top and bottom. Make sure cutter is approximately level.

3. With full cutter weight lowered onto jackstands, test blocking stability before working underneath.
4. If cutter is attached to tractor when blocking, set the brakes, remove key, and block cutter before working underneath.
5. Securely block rear tractor wheels, in front and behind. Tighten tractor lower 3-point arm anti-sway mechanism to prevent side-to-side movement.

## LUBRICATION

Do not let excess grease collect on or around parts, particularly when operating in sandy areas.

See Figure 10 for lubrication points and frequency or lubrication based on normal operating conditions. Severe or unusual conditions may require more frequent lubrication.

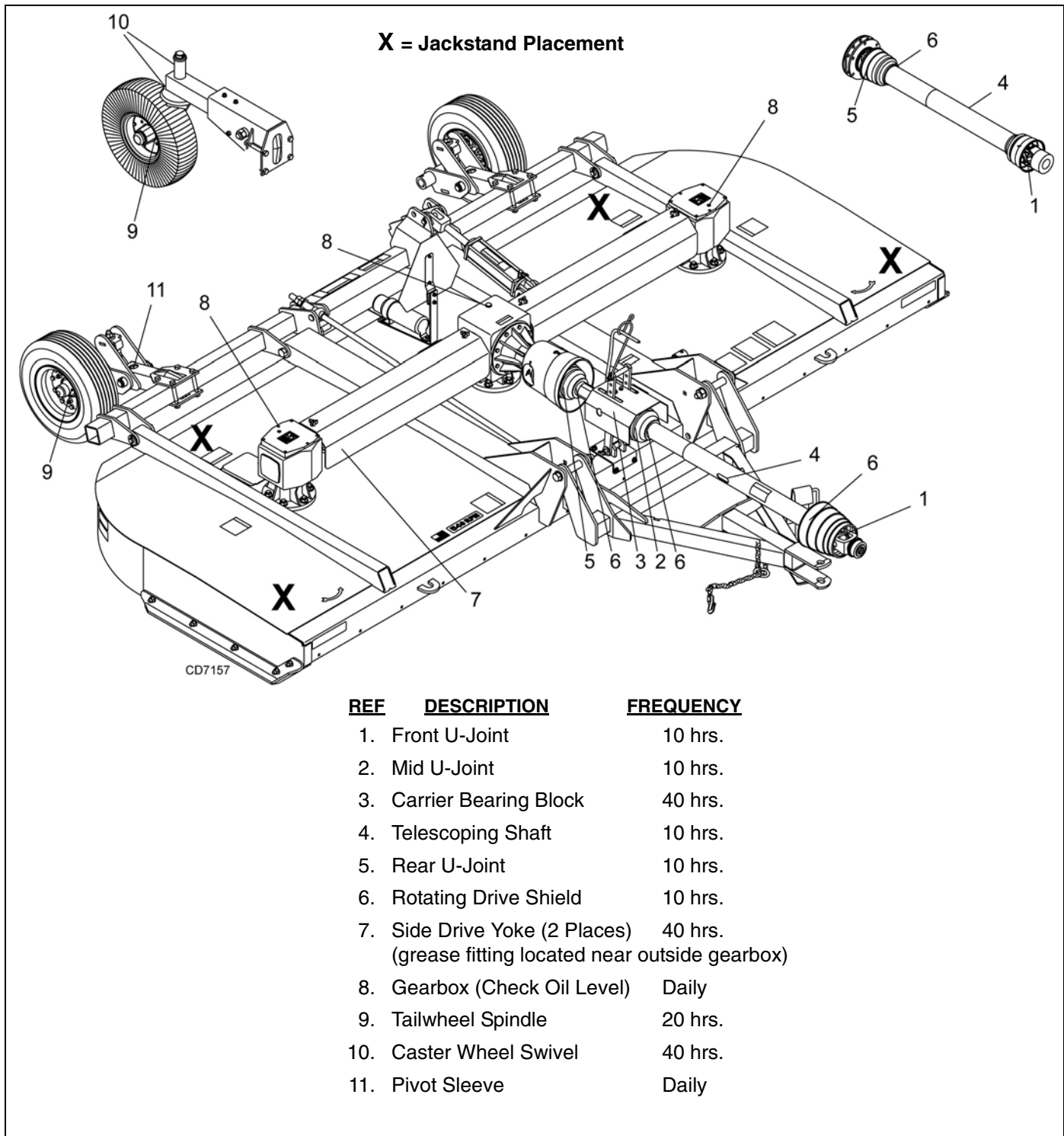
Use a lithium grease of #2 consistency with a MOLY (molybdenum disulfide) additive for all locations unless otherwise noted. Be sure to clean fittings thoroughly before attaching grease gun. One good pump of most guns is sufficient when the lubrication schedule is followed.

## **Gearbox Lubrication**

1. For gearbox, use a high quality gear oil with a viscosity index of 80W or 90W and an API service rating of GL-4 or -5 in gearboxes.
2. Fill gearbox until oil runs out the side plug on side of gearbox or oil level is between rings on dipstick when it is seated on top of gearbox. Check gearbox daily for evidence of leakage, and contact your dealer if leakage occurs.

## **Driveline Lubrication (Figure 10)**

1. Lubricate the driveline slip joint every ten operating hours. Failure to maintain proper lubrication could result in damage to U-joints, gearbox, and driveline.
2. Lower cutter to ground, disconnect driveline from tractor PTO shaft, and slide halves apart but do not disconnect from each other.
3. Apply a bead of grease completely around male half where it meets female half. Slide drive halves over each other several times to distribute grease.



**Figure 10.** Jackstand Placement and Lubrication Points

## **BLADE SERVICING**

### **Removing Blades (Figure 11)**

#### ***NOTICE***

■ If blade pin (1) is seized in crossbar and extreme force will be needed to remove it, support crossbar from below to prevent gearbox damage.

1. Disconnect driveline from tractor PTO.
2. Open blade access cover and align crossbar (3) with blade access hole in the cutter frame. Remove nut (5), top blade if installed, and bushing (4) from blade pin. Drive pin (1) out of crossbar (3).
3. Rotate crossbar (3) and repeat for opposite blade.

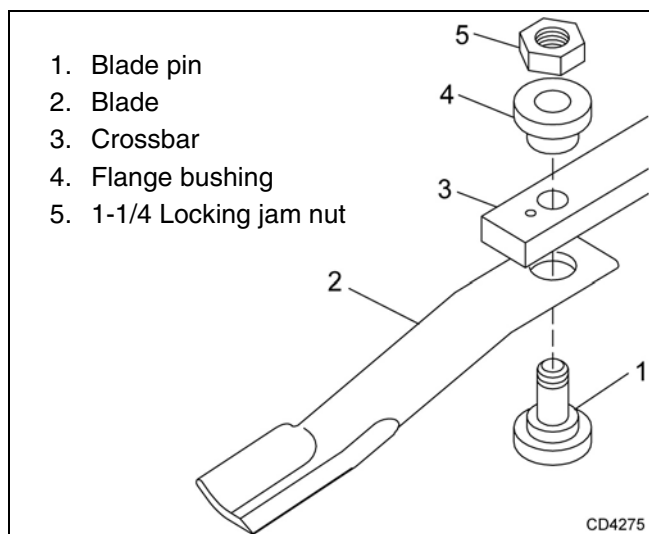
### **Installing Blades**

#### **⚠ CAUTION**

■ Your dealer can supply genuine replacement blades. Substitute blades may not meet original equipment specifications and may be dangerous.

#### ***NOTICE***

■ Crossbar rotation viewed from the top of the cutter, is counter-clockwise for the right gearbox and clockwise rotation on the left gearbox; the center crossbar is counter-clockwise on the 540 rpm models and clockwise on the 1000 rpm models. Be sure to install blade cutting edge to lead in correct rotation.



**Figure 11.** Blade Assembly

**NOTE:** Always replace or sharpen both blades at the same time.

1. Inspect blade bolt (1) and bushing (4) for nicks or gouges. Replace blade bolt if any defects are found, Always replace lock nut (5) when changing blades.
2. Insert blade pin (1) through blade (2), align key on blade pin with keyway in crossbar, and push blade pin through crossbar.
3. Install upper blade, if using shredder kit, and bushing (4). Place a few drops of oil on pin and torque nut to 644 lbs-ft.
4. Repeat steps for opposite side.

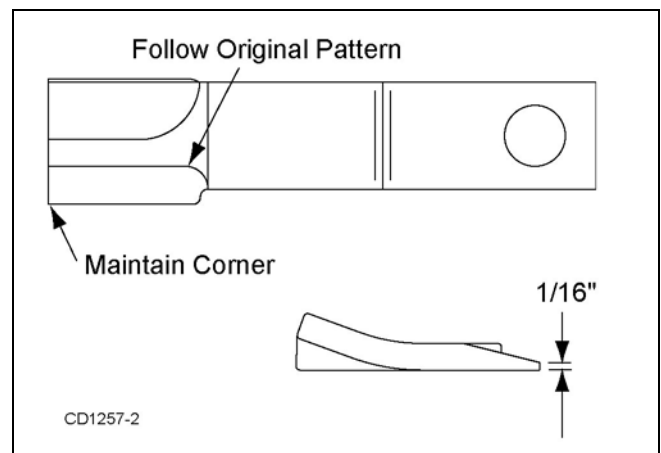
**NOTE:** Blade should be snug but should swivel on pin without having to exert excessive force. Operating cutter when blades do not freely swing will cause excessive vibration.

### **Sharpening Blades**

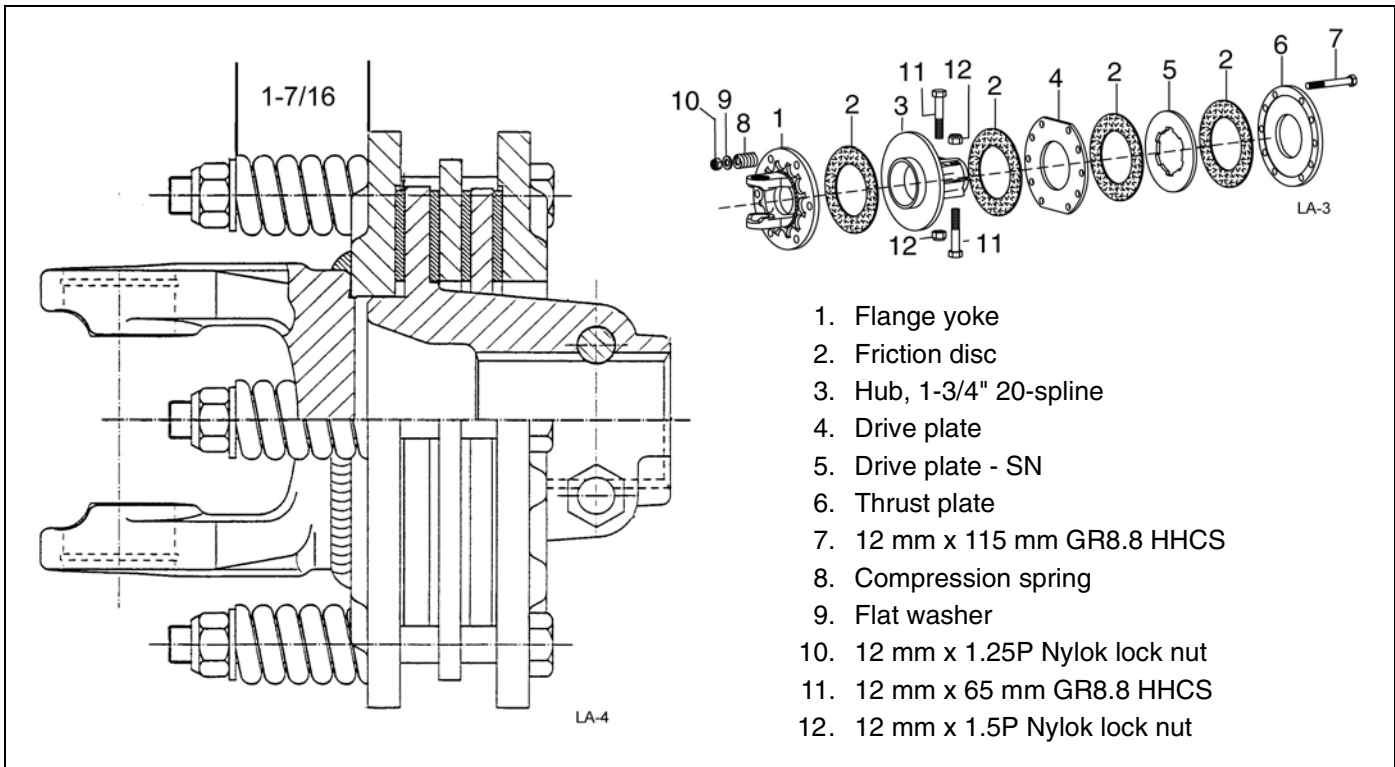
#### ***NOTICE***

■ When sharpening blades, grind the same amount on each blade to maintain balance. Replace blades in pairs. Unbalanced blades will cause excessive vibration, which can damage gearbox bearings. Vibration may also cause structural cracks to cutter.

1. Sharpen both blades at the same time to maintain balance. Follow original sharpening pattern.
2. Do not sharpen blade to a razor edge—leave at least a 1/16" blunt edge.
3. Do not sharpen back side of blade.



**Figure 12.** Sharpen Blade Cutting Edge



**Figure 13.** Slip Clutch Assembly

## **SLIP CLUTCH ADJUSTMENT**

The slip clutch is designed to slip so that the gearbox and driveline are protected if the cutter strikes an obstruction.

A new slip clutch or one that has been in storage over the winter may seize. Before operating the cutter, make sure it will slip by performing the following operation:

1. Turn off tractor engine and remove key.
2. Remove driveline from tractor PTO.
3. Loosen six 12 mm cap screws (7) to remove all tension from compression spring (8).
4. Hold clutch hub (3) solid and turn shaft to make sure clutch slips.
5. If clutch does not slip freely, disassemble and clean the flange yoke (1), clutch hub (3), drive plate (5), and thrust plate faces (6).
6. Reassemble clutch.
7. Compress each of the six compression springs (8) by tightening the six cap screws (7) and lock nuts (10). The compression springs should be compressed to a height of 1-7/16", not including washer (9). The minimum spring height is 1.36". See Figure 13.

8. If a clutch continues to slip when the springs are compressed to 1.36", check friction discs (2) for excessive wear. Discs are 1/8" when new. Replace discs after 1/16" wear. Minimum disc thickness is 1/16".

## **SHIELDING REPAIR**

### **⚠ DANGER**

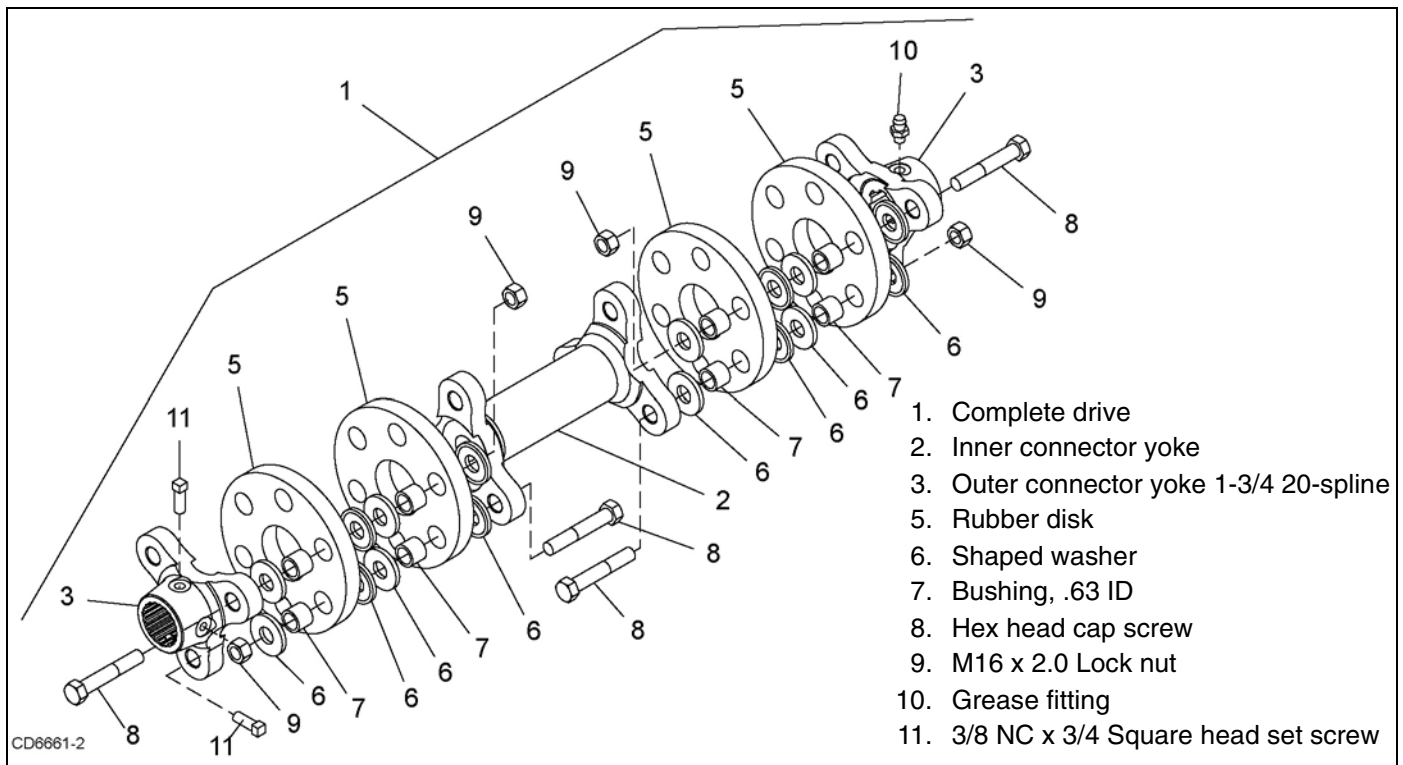
■ Full chain shielding must be installed when operating in populated areas or other areas where thrown objects could injure people or damage property.

- If this machine is not equipped with full chain shielding, operation must be stopped when anyone comes within 300 feet (92 m).
- This shielding is designed to reduce the risk of thrown objects. The mower deck and protective devices cannot prevent all objects from escaping the blade enclosure in every mowing condition. It is possible for objects to ricochet and escape, traveling as much as 300 feet (92 m).

### **Repairing Optional Chain Shielding**

Inspect chain shielding each day of operation and replace any broken or missing chains as required.





**Figure 14.** Flexible Coupler

## **FLEXIBLE COUPLER RUBBER DISK REPLACEMENT**

The flexible coupler side drive is designed to flex when striking heavy objects or during start-up to protect gear-boxes. The rubber disks will wear out over time and require replacement much like slip clutch disks. To maximize rubber disk life, lower tractor engine speed to an idle when engaging the PTO and avoid striking the ground with cutter blades.

Periodically inspect the disks for signs of cracking. A disk may run for some time after a crack starts but this is the first sign that disk replacement is required in the future.

To replace the disks, remove hardware items 6, 7, 8, and 9. Remove sleeves (7) from old disk and install in new disk. Reassemble and torque bolts to 85 lbs-ft. See Figure 14. Take special care not to rotate gearbox shaft and throw blades out of time. If rubber disks have failed and blades are hitting, you will need to re-time the blades per instructions on page 36.

## **SERVICING TIRES SAFELY**

### **Used Aircraft Tires (Figure 15)**

Do not attempt to mount a tire unless you have the proper equipment and experience to perform the job.

Always maintain the correct tire pressure. Do not inflate tires above the recommended pressure. Never weld or heat a wheel and tire assembly. The heat can cause an increase in air pressure and result in a tire explosion. Welding can structurally weaken or deform the wheel.

### **⚠ WARNING**



■ Explosive separation of tire and rim parts can cause serious injury or death. Release all air pressure before loosening bolts.

When inflating tires, use a clip-on chuck and an extension hose long enough to allow you to stand to the side — not in front of or over the tire assembly. Use a safety cage if available.

Check wheels for low pressure, cuts, bubbles, damaged rims, or missing lug bolts and nuts.

Never remove split rim assembly hardware (A) with the tire inflated.



Figure 15. Split Rim Tire Servicing

## **CLEANING**

### **After Each Use**

- Remove large debris such as clumps of dirt, grass, crop residue, etc. from machine.

- Inspect machine and replace worn or damaged parts.
- Replace any safety decals that are missing or not readable.

### **Periodically or Before Extended Storage**

- Clean large debris such as clumps of dirt, grass, crop residue, etc. from machine.
- Remove the remainder using a low-pressure water spray.
  1. Be careful when spraying near scratched or torn safety decals or near edges of decals as water spray can peel decal off surface.
  2. Be careful when spraying near chipped or scratched paint as water spray can lift paint.
  3. If a pressure washer is used, follow the advice of the pressure washer manufacturer.
- Inspect machine and replace worn or damaged parts.
- Sand down scratches and the edges of areas of missing paint and coat with Woods spray paint of matching color (purchase from your Woods dealer).
- Replace any safety decals that are missing or not readable (supplied free by your Woods dealer). See Safety Decals section for location drawing.



# TROUBLESHOOTING

PROBLEM	POSSIBLE CAUSE	SOLUTION
Does not cut	Dull blades Worn or broken blades Incorrect PTO speed Ground speed too fast Drive not functioning (blades do not turn when PTO is running) Gearbox malfunction Excessive clutch slippage Incorrect blade direction	Sharpen blades. Replace blades. (Replace in pairs only.) Set at rated PTO speed. Reduce ground speed. Check drive shaft connection. Check gearbox. Repair gearbox. Adjust clutch. Check to be sure blade edge is correct for direction of rotation.
Streaks or ragged cut	Broken or worn blades Attitude incorrect Ground speed too fast Excessive cutting height Excessive lush and tall vegetation	Replace or sharpen blades. Level machine. Reduce ground speed. Lower cutting height. (Note: Set height so blades do not frequently hit ground.) Recut at 90° to first pass.
Excessive side skid wear	Running with skids continuously on ground	Raise cutting height or adjust.
Excessive clutch slippage	Clutch out of adjustment Clutch discs worn; wear stops contacting opposite plate Blades hitting ground	Adjust clutch. Replace discs. Raise cutting height.
Vibration	Broken blade Bearing failure Hitch length incorrect Universal drive Flexible coupler is binding	Replace blades in pairs. Check gearbox shafts for side play. Reset hitch length. Adjust pedestal bearing height to be parallel to ground. Lubricate grease fitting on spline yoke.
Blades hitting deck	Bent blades or crossbar	Replace bent blades or crossbar.
Blades hitting each other	Side drive failure	Retime blades, or replace rubber coupler disks. See page 36.
Unit will not raise	Low oil	Add hydraulic oil.

# NOTES

# DEALER SERVICE

The information in this section is written for dealer service personnel. The repair described here requires special skills and tools. If your shop is not properly equipped or your mechanics are not properly trained in this type of repair, you may be time and money ahead to replace complete assemblies.

## WARNING

■ Before working underneath, disconnect drive-line, raise cutter, lock in transport position, and block cutter securely. Hydraulic system leak down and failure of mechanical or hydraulic system can cause equipment to drop.

■ Keep all persons away from operator control area while performing adjustments, service, or maintenance.

## CAUTION

■ Always wear relatively tight and belted clothing to avoid getting caught in moving parts. Wear sturdy, rough-soled work shoes and protective equipment for eyes, hair, hands, hearing, and head; and respirator or filter mask where appropriate.

## GEARBOX MAINTENANCE

**NOTE:** Read this entire section before starting any repair. Many steps are dependent on each other.

1. Fill gearbox with SAE 80W or 90W gear lube until it runs out the side level plug or oil level is between rings on dipstick when it is seated on top of gearbox.

**NOTE:** Repair to this gearbox is limited to replacing bearings, seals, and gaskets. Replacing gears, shafts, and a housing is not cost effective. Purchasing a complete gearbox is more economical.

2. Inspect gearbox for leakage and bad bearings. Leakage is a very serious problem and must be corrected immediately. Bearing failure is indicated by excessive noise and side-to-side or end-play in gear shafts.

## Seal Replacement

Recommended sealant for gearbox repair is Permatex<sup>®</sup> Aviation 3D Form-A-Gasket or equivalent.

Leakage can occur at the vertical or horizontal gaskets and shaft seals.

Leakage at the horizontal gasket or seal can be repaired without removing the gearbox from the cutter.

## Seal Installation

**NOTE:** Proper seal installation is important. An improperly installed seal will leak.

1. Clean area in housing where seal outer diameter (OD) seats. Apply a thin coat of Permatex.
2. Inspect area of shaft where seal seats. Remove any burrs or nicks with an emery cloth.
3. Lubricate gear shaft and seal lips.
4. Place seal squarely on housing, spring-loaded lip toward housing. Select a piece of pipe or tubing with an OD that will sit on the outside edge of the seal but will clear the housing. Tubing with an OD that is too small will bow seal cage and ruin seal.
5. Carefully press seal into housing, avoiding distortion to the metal seal cage.

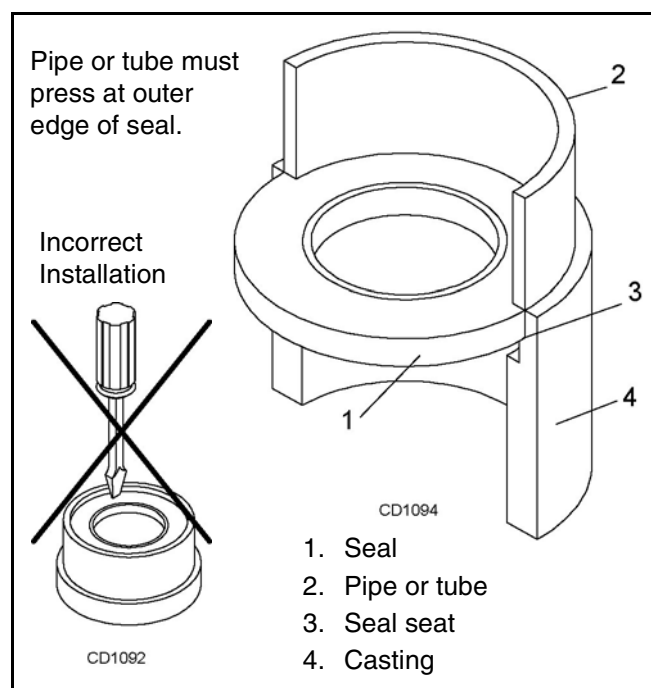


Figure 13. Seal Installation

## Vertical Shaft Seal Repair

Refer to Figure 14.

1. Disconnect and remove the rear driveline from the gearbox.
2. Remove vent plug (22) and siphon gear lube from housing through this opening.
3. Remove crossbar (see Crossbar, page 34).
4. Remove protective seal (11) and vertical shaft seal (12). Replace seal (12) with new seal (see Seal Replacement page 29).

Vertical seal should be recessed in housing. Horizontal seal (3) should be pressed flush with outside of housing.

**NOTE:** Distortion to seal cage or damage to seal lip will cause seal to leak.

5. Fill gearbox with SAE 80W or 90W gear lube until it runs out the level plug.
6. Remove and replace any seal damaged in installation.

### Horizontal Shaft Seal Repair (Figure 14)

1. Disconnect and remove the rear driveline from the gearbox.
2. Remove vent plug (22) and siphon gear lube from housing through this opening.
3. If the leak occurred at either end of horizontal shaft, remove oil cap (16) and/or oil seal (3). Replace with new one (refer to Seal Installation, page 29).
4. Fill gearbox with SAE 80W or 90W gear lube until it runs out the level plug.

### SIDE GEARBOX REPAIR (Figure 14)

**NOTE:** Replacing gears, shafts, bearings, and seals may not be cost effective. Purchasing a complete gearbox may be more economical.

### Remove Gearbox from Cutter

1. Disconnect and remove flex side driveline from the gearbox.
2. Remove cotter pin and nut from vertical shaft and remove crossbar (see Crossbar, page 34).
3. Remove breather level plug (22) and siphon gear lube from housing through this opening.
4. Remove the six bolts that attach gearbox to cutter and remove gearbox.

### Disassemble Gearbox

1. Remove plug from side of gearbox and pour out gear oil.
2. Remove oil cap (16) (to be replaced).
3. Remove snap ring (5) and shim (6) from input shaft (4).
4. Support gearbox in hand press and push on input shaft (4) to remove bearing (2).
5. Remove six cap screws (21) and top cover (20) from housing. Remove gear (1a or 1b) from inside housing.
6. Remove oil seal (3) from front of housing (to be replaced).
7. Remove snap ring (5) and shim (6) from front of housing.

8. Remove input bearing (2) by using a punch and hammer from outside of housing.
9. Support housing in vise in a horizontal position.
10. The castle nut (23), cotter pin (24), and hub are already removed with the stump jumper/crossbar. Remove the protective seal (11), and oil seal (12).
11. Remove cotter pin (15), castle nut (8), and washer (19) from output shaft (14).
12. Remove output shaft (14) by using a punch and hammer and tap on top to drive down. Remove gear (1a or 17) and shim (9) from inside housing.
13. Remove bottom bearing (13) by using a punch and hammer from the top, outside the housing.
14. Support housing upside down (top cover surface) and remove top bearing (10) by using a punch and hammer from the bottom side of the housing.
15. Inspect gears for broken teeth and wear. Some wear is normal and will show on loaded side. Forged gear surfaces are rough when new. Check that wear pattern is smooth.
16. Inspect vertical and horizontal shafts for grooves, nicks, or bumps in the areas where the seals seat. Resurface any damage with emery cloth.
17. Inspect housing and caps for cracks or other damage.

### Assemble Gearbox

1. Clean housing, paying specific attention to areas where gaskets will be installed.
2. Wash housing and all components thoroughly. Select a clean area for gearbox assembly. Replace all seals, bearings, and gaskets. All parts must be clean and lightly oiled before reassembling.
3. Insert both output bearings (10 & 13) in the housing, using a round tube of the correct diameter and a hand press.
4. Slide output shaft (14) through both bearings (10 & 13) until it rests against top bearing (10).
5. Slide shim (9) over output shaft (14).
6. Press gear (1a or 17) onto output shaft (14) and secure with washer (19), castle nut (8), and cotter pin (15).
7. Apply grease to lower seal lips (12) and press seal (12) over output shaft (14), using a tube of the correct diameter. Be sure not to damage seal lip.
8. Press in housing so that seal is recessed. Press protective seal (11) until seated flush with housing. Verify that the seal (11) is seated correctly.
9. Press bearing (2) into the housing, using a round tube of the correct diameter and a hand press. Secure with shim (6) and snap ring (5).

10. Secure snap ring (5) on input shaft (4) if not already secure.
11. Place gear (1a or 1b) through top of housing and align gear (1a or 1b) and gear (1a or 17) so that gear teeth are a match.
12. While holding gear (1a or 1b) in place, slide input shaft (4) through gear (1a or 1b) and bearing (2). Align splines on shaft (4) and gear (1a or 1b). Slide spacer (18) over input shaft (4) and press bearing (2) onto input shaft (4), using a round tube of the correct diameter and a hand press.
13. Slide shim (6) over input shaft (4) and secure with snap ring (5).
14. Check input shaft end float by moving the input shaft (4) by hand. If end float is higher than 0.012", insert shim between input shaft (4) and rear bearing (2). Repeat until end float is less than 0.012". Check rotational torque by hand. The torque should be less than 2.2 lbs-inch.
15. Check that the gear backlash is between 0.006" and 0.016". You should not have to adjust the backlash.

16. Press in input oil seal (3), using tube of correct diameter. Be careful not to damage seal lip.
17. Press oil cap (16) on to cover the rear of housing, using a tube of the correct diameter.
18. Place top cover (20) on top of housing and secure with six cap screws (21).
19. Check gearbox housing for leaks by plugging all holes except one. Apply 4 psi compressed air and immerse the gearbox in water to verify that there are no leaks.
20. Remove gearbox from water and dry off with compressed air. Add SAE 80W or 90W EP oil until it runs out of side level hole. Tighten all plugs.

## Reinstall Gearbox

**NOTE:** Gearbox is heavy: do not attempt to move without mechanical assistance.

1. Set gearbox on cutter and fasten with bolts and nuts. Torque bolts to 300 lbs-ft.
2. Attach crossbar (Crossbar Installation, page 35).

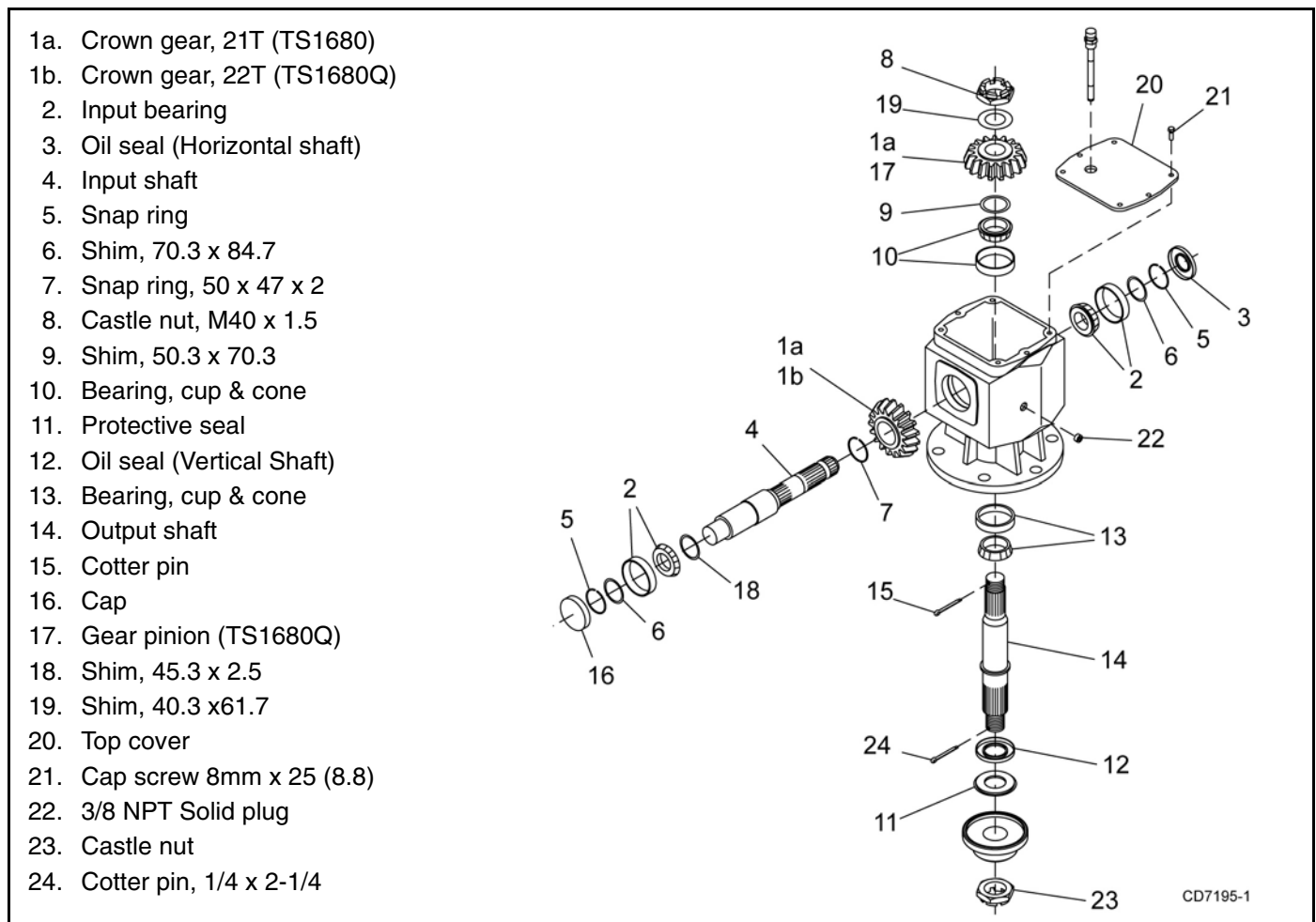


Figure 14. Side Gearbox Assembly

## **CENTER GEARBOX REPAIR (FIGURE 15)**

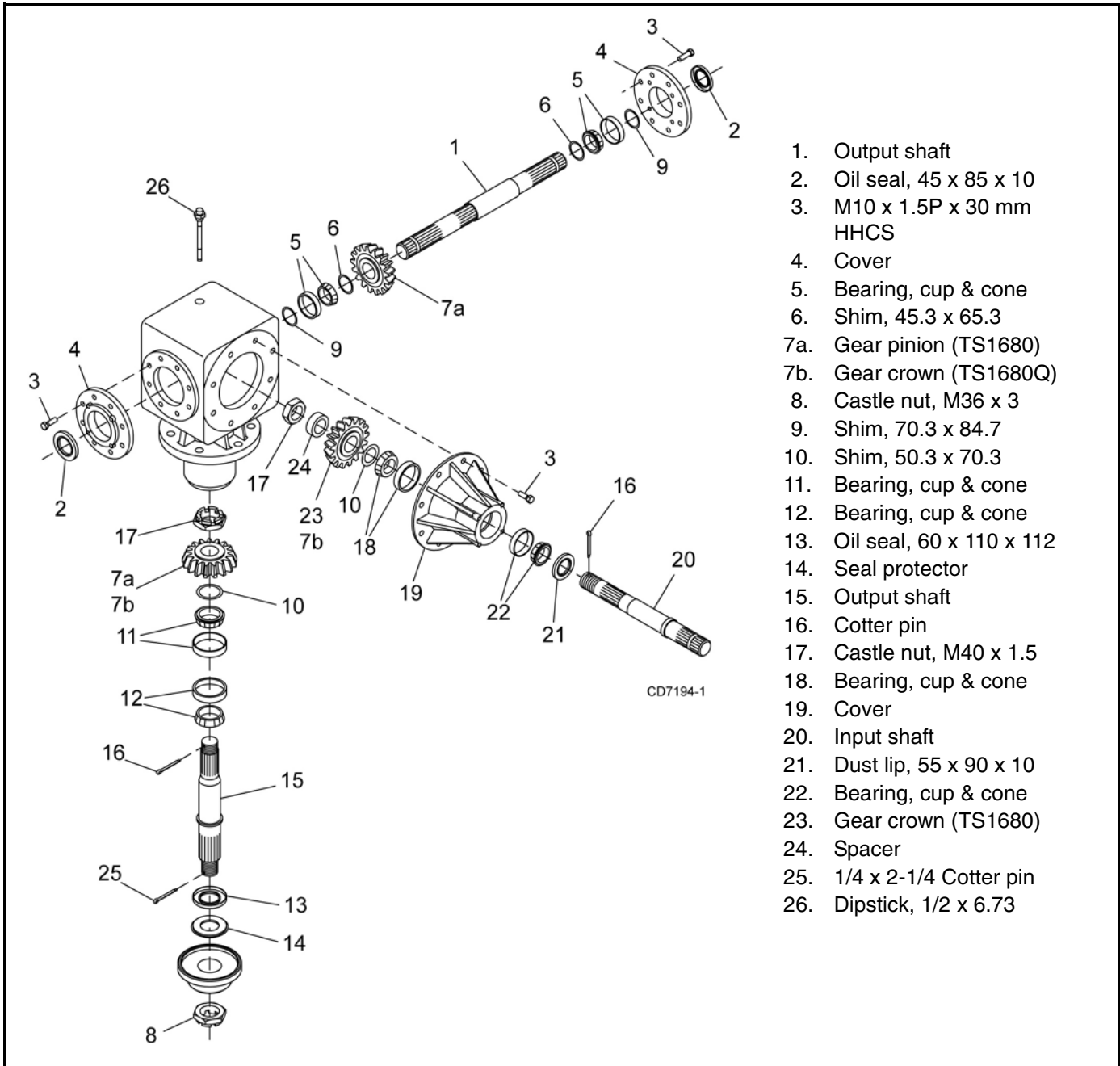
**NOTE:** Replacing gears, shaft, bearings, and seals may not be cost effective. Purchasing a complete gearbox may be more economical.

### **Remove Gearbox from Cutter**

1. Disconnect driveline from the tractor PTO and remove it from center gearbox.
2. Remove dipstick plug (26) and siphon gear lube from housing through this opening.

**NOTE:** Flex coupler driveline can not be removed when center and side gearboxes are bolted in place.

3. Disconnect and remove flex coupler driveline from side of gearbox by:
  - a) Removing six  $\frac{3}{4}$  x 1-1/2 cap screws and  $\frac{3}{4}$  hex nuts from around center gearbox.
  - b) Removing tapered cap screw and hex nut from flex coupler yoke.
  - c) Rotating gearbox and slide flex coupler from gearbox shaft.



**Figure 15.** Center Gearbox Assembly



## Disassemble Gearbox (Figure 15)

1. Remove dipstick plug from top of gearbox and siphon gear lube from housing.
2. Remove ten 10 mm cap screws (3) from around input housing (19). Remove input shaft assembly and housing.
3. Remove eight 10 mm cap screws (3) from each side of gearbox housing. Remove cover (4) and seal (2) from both sides of output shaft (1).
4. Remove shims (9) from both sides of output shaft (1).
5. Support gearbox in a hand press and push on the left side of output shaft (1) to remove right bearing (5), shim (6) and gear (7a) from housing.
6. Support housing in vise in horizontal position.
7. Remove left bearing (5) and shim (6) by using a punch and hammer from right side of housing. Drive bearing out of housing.
8. Support housing in vise in a horizontal position.
9. The castle nut (8), cotter pin (25), and hub are already removed with the crossbar. Remove the protective seal (14), and oil seal (13).
10. Remove cotter pin (16), castle nut (17), gear (7a or 7b), and shim (10) from vertical output shaft (15).
11. Remove vertical output shaft (15) by using a punch and hammer and tap on top to drive down.
12. Remove bottom bearing (12) by using a punch and hammer from the top, outside the housing.
13. Support housing upside down and remove top bearing (11) by using a punch and hammer from the bottom side of the housing.
14. Remove cotter pin (16), castle nut (17), spacer (24), gear (23 or 7b), and shim (10) from input shaft (20).
15. Remove seal (21) from input housing (19).
16. Support input housing in a vise and remove bearing (22) by using a punch and hammer. Drive bearing out of housing.
17. Inspect gears for broken teeth and wear. Some wear is normal and will show on loaded side. Forged gear surfaces are rough when new. Check that wear pattern is smooth.
18. Inspect vertical and horizontal shafts for grooves, nicks or bumps in the areas where the seals seat. Resurface any damage with emery cloth.
19. Inspect housing and caps for cracks or other damage.

## Assemble Gearbox (Figure 15)

1. Clean housing, paying specific attention to areas where gaskets will be installed.

2. Wash housing and all components thoroughly. Select a clean area for gearbox assembly. Replace all seals, bearings and gaskets. All parts must be clean and lightly oiled before reassembly.
3. Insert both output bearings (11 & 12) in the housing, using a round tube of the correct diameter and a hand press.
4. Slide output shaft (15) through both bearings (11 & 12) until it rests against top bearing (11).
5. Slide shim (10) over output shaft (15).
6. Press gear (7a or 7b) over output shaft (15) and secure with castle nut (17) and cotter pin (16).
7. Apply grease to lower seal lips (13) and press seal (13) over output shaft (15), using a tube of the correct diameter. Be sure not to damage seal lip.
8. Press in housing so that seal is recessed. Press protective seal (14) until seated flush with housing. Verify that the seal (13) is seated correctly.
9. Install seal (2) in cover (4) using a tube of the correct diameter. Be sure not to damage seal.
10. Install cover (4) onto right side of housing using eight 10 mm cap screws (3).
11. Press shim (9) and bearing (5) in right side of gearbox housing using a round tube of the same diameter and a hand press.
12. Place shim (6) and gear (7a) inside of gearbox housing.
13. Insert output shaft (1) through opening in left side of gearbox, gear (7a), shim (6), bearing (5) and shim (9) on right side of housing.
14. Place second shim (6), bearing (5), and shim (9) on left side of output shaft (1).
15. Place cover (4) over left end of output shaft (1) and secure to housing using eight 10 mm cap screws (3).
16. Place seal (2) over output shaft (1) and press into cover (4) using a tube of the correct diameter.
17. Press bearing (22) into input housing (19), using a round tube of the same diameter and a hand press.
18. Assemble bearing (18), shim (10), gear (7b or 23) onto input shaft (20). Secure with spacer (24), castle nut (17) and cotter pin (16).
19. Insert input shaft assembly into gearbox housing and align teeth of the three gears.
20. Place input housing (19) over input shaft and secure into position using cap screws (3).
21. Place seal (21) over input shaft on cover and press into housing using a tube of the same diameter.
22. Check gearbox housing for leaks by plugging all holes except one. Apply 4 psi compressed air and

immerse the gearbox in water to verify that there are no leaks.

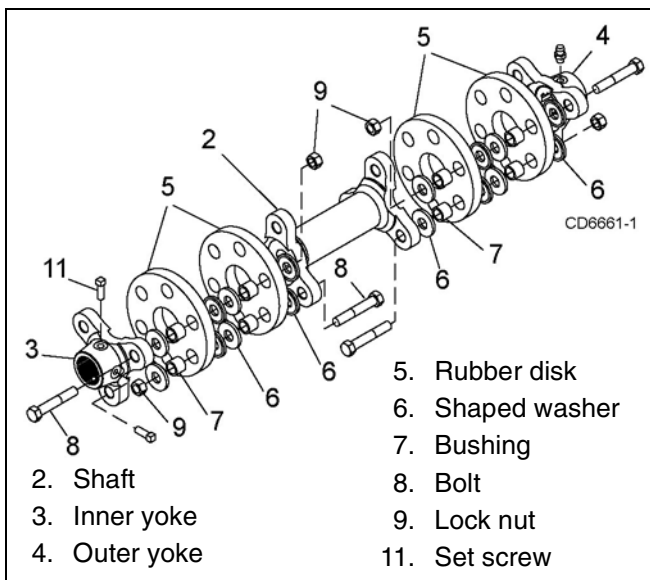
23. Remove gearbox from water and dry off with compressed air. Add SAE 80W or 90W EP oil until level is between rings of dipstick (26) with dipstick seated. Tighten all plugs.

## Reinstall Gearbox

**NOTE:** Gearbox is heavy: do not attempt to move it without mechanical assistance.

1. Install flex coupler driveline between side gearboxes and center gearbox.
2. Set gearbox on cutter and fasten with bolts and nuts. Torque bolts to 300 lbs-ft.

## SIDE DRIVE SERVICE



**Figure 16.** Side Drive Assembly

The drives between the center and side gearboxes contain rubber shock-absorbing discs. To service or remove the side drives or remove a gearbox, the flexible coupling must be disassembled. See page 25 for rubber disk replacement.

Remove end yokes by removing nuts (9) and sliding bolt (8) inward to clear yoke. Do not remove bolt unless rubber disks (5) are to be serviced. Remove complete center section by lifting straight up on center shaft (2). The outer yoke can be slid off gearbox shaft. The inner yoke is held by two set screws (11).

Reassemble shaft as shown in Figure 16. End yokes (3 & 4) do not bolt directly to center shaft (2). Use the special formed washer (6) and bushings (7) between the rubber disks (5) and under bolt head or nut near rubber disc. Tighten nuts (9) and bolts (8) to 85 lbs-ft. Tighten set screw (11).

**NOTE:** Crossbar must be re-timed anytime a crossbar or a side drive is disconnected. (See page 36.)

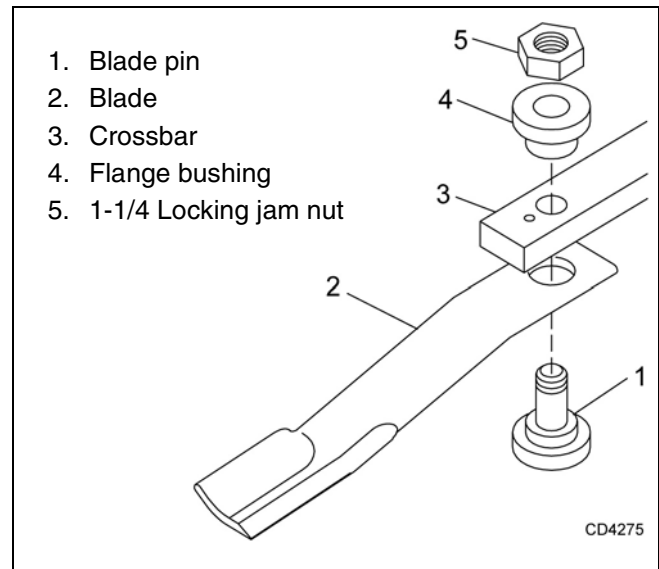
## CROSSBAR

### Crossbar Removal

1. Access bottom side of cutter for crossbar removal. See BLOCKING METHOD, page 21.

**NOTE:** You will need to use either the puller screw (Item 6, Figure 18) or a small hydraulic jack to remove the crossbar.

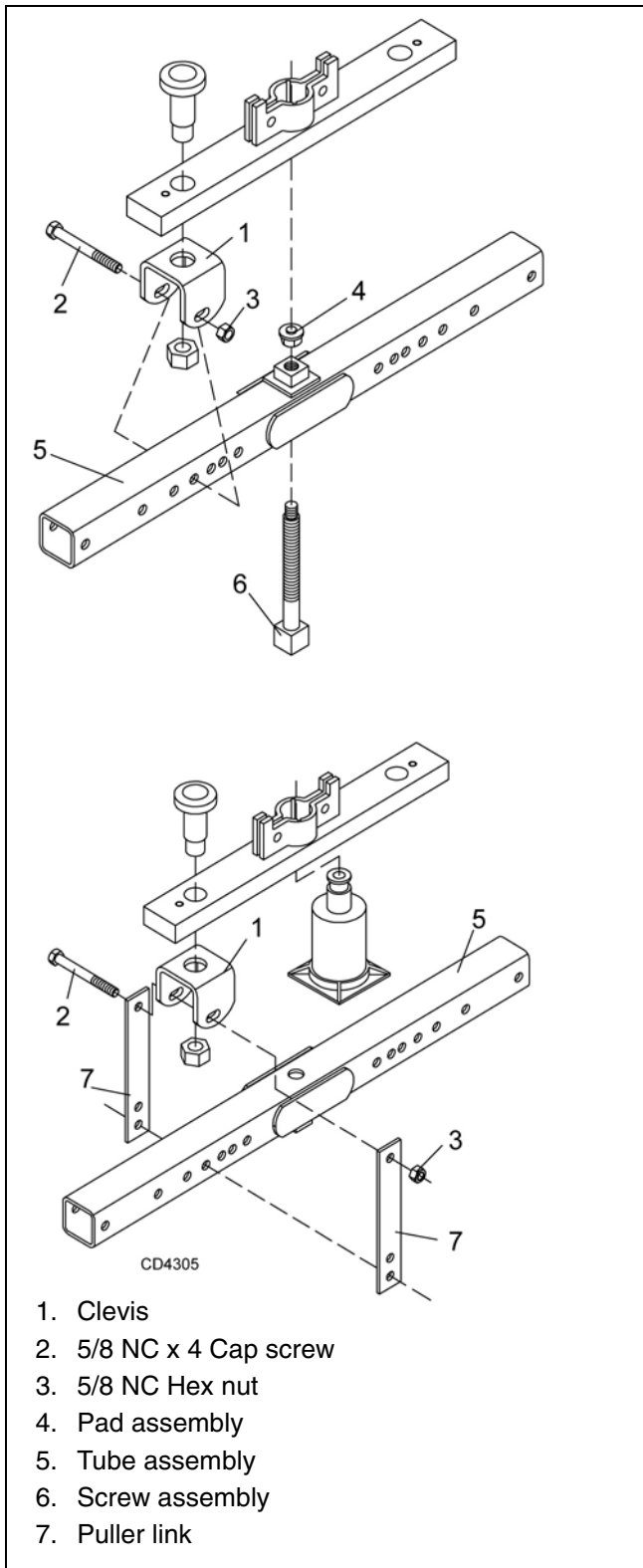
2. Remove blades as shown in Figure 17.



**Figure 17.** Blade Removal

3. Remove cotter pin and castle nut from bottom of crossbar.
4. Refer to Figure 18. Attach a clevis (1) to each end of crossbar, using blade pins and nuts.
5. Position tube assembly (5) with threaded nut toward crossbar for puller screw removal or down for hydraulic jack removal.
6. For removal with puller screw, attach tube (5) to each clevis with bolts (2) and nuts (3). Place pad (4) in nut and thread puller screw (6) into nut from bottom. Tighten until pad is solid against gearbox shaft. For best results, strike head of puller screw with a hammer while tightening with a wrench.
7. For removal with a jack, attach tube to each clevis with puller links (7), bolts (2), and nuts (3). Place jack on tube with end of jack pressing against gearbox shaft. Slowly apply force with jack.

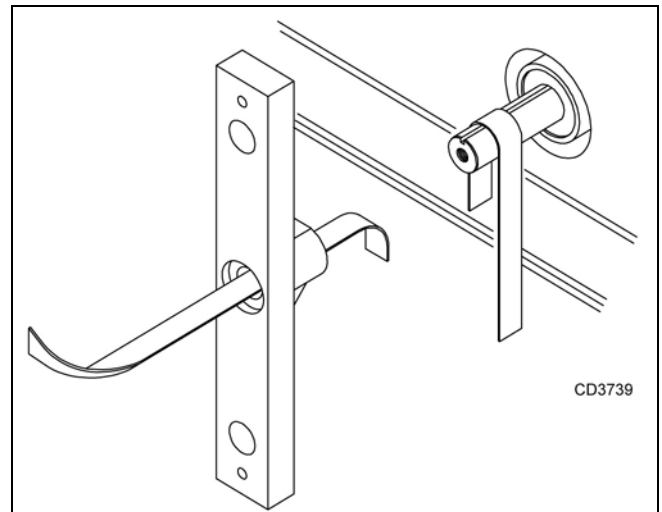
**NOTE:** Hydraulic jack will not operate if tipped more than 90-degrees. Use care to prevent bending crossbar during removal.



**Figure 18.** Crossbar Removal

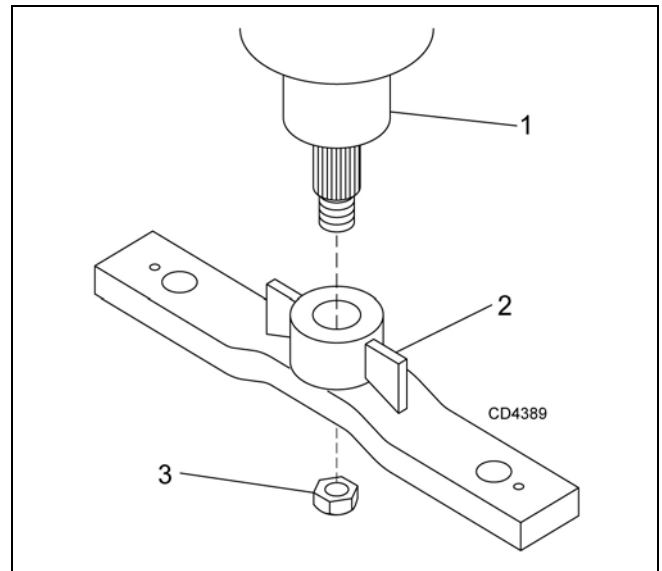
## Crossbar Installation

1. Using emery cloth (220 or finer), remove surface rust, and foreign material from hub, splined gearbox vertical shaft, and crossbar. See Figure 19.

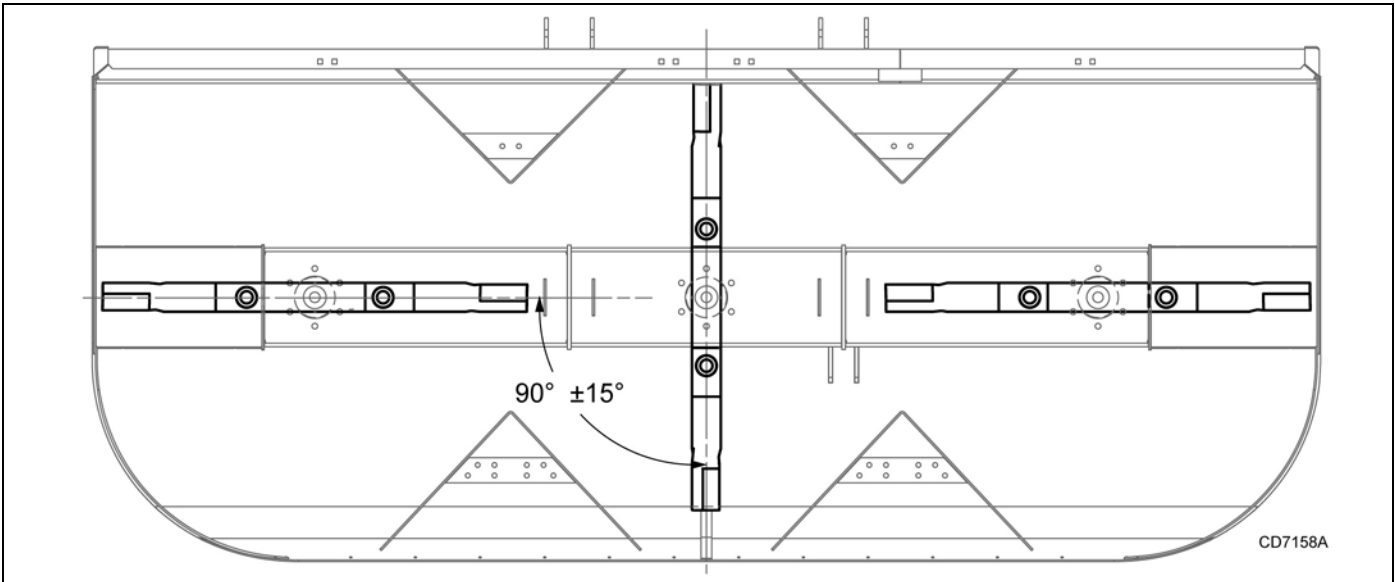


**Figure 19.** Typical Crossbar and Gearbox Shaft

2. Install crossbar (2) on splined shaft. See Figure 20. Install nut (3). Torque nut to 450 lbs-ft. Install cotter pin.



**Figure 20.** Crossbar Installation



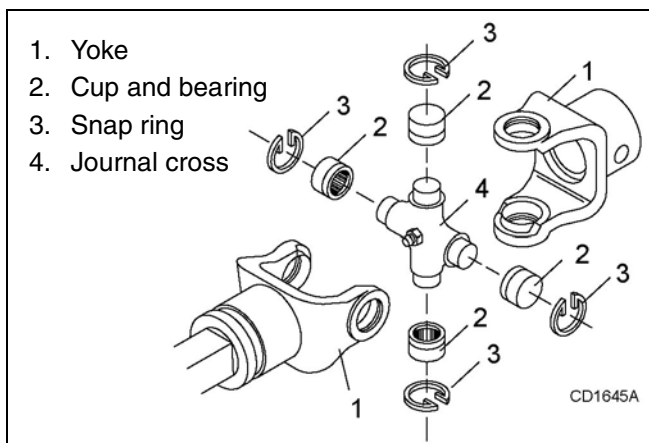
**Figure 21.** Crossbar Timing - Bottom View

### Crossbar Timing

Crossbar must be re-timed anytime a crossbar or a side drive is disconnected.

1. To re-time crossbars, position bars as shown in Figure 21.
2. The center crossbar will be at right angles to the front of the cutter.
3. The left and right crossbars should be perpendicular to the center crossbar.
4. Hold crossbars in position while connecting the side drivelines.

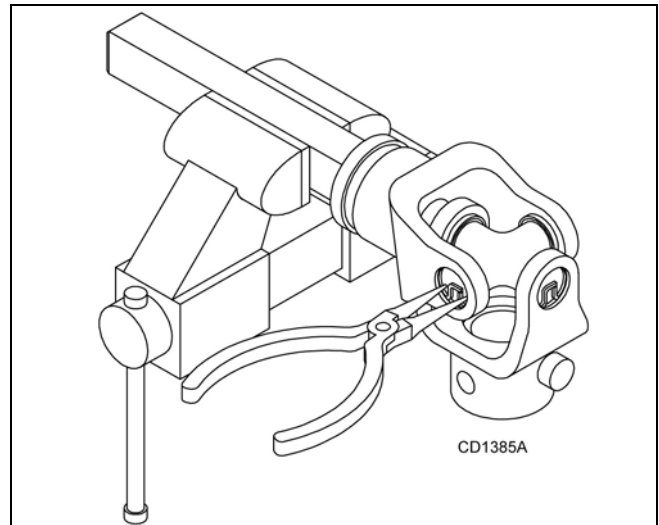
### UNIVERSAL JOINT REPAIR



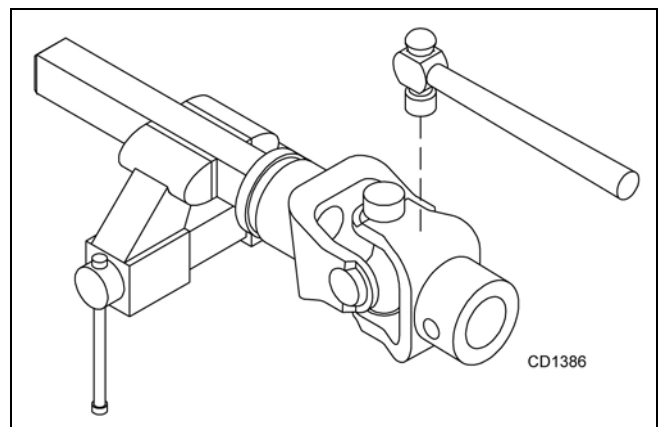
**Figure 22.** Universal Joint Exploded View

### U-Joint Disassembly

1. Remove external snap rings from yokes in four locations as shown in Figure 23.

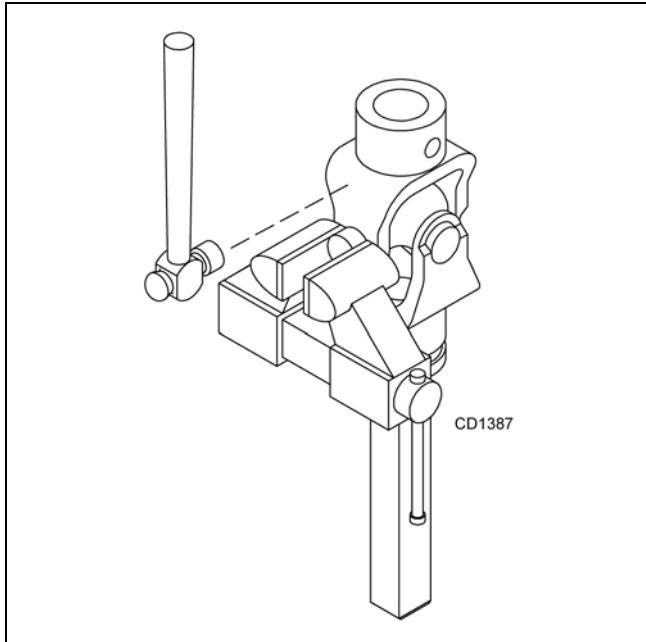


**Figure 23.** Remove Snap Ring



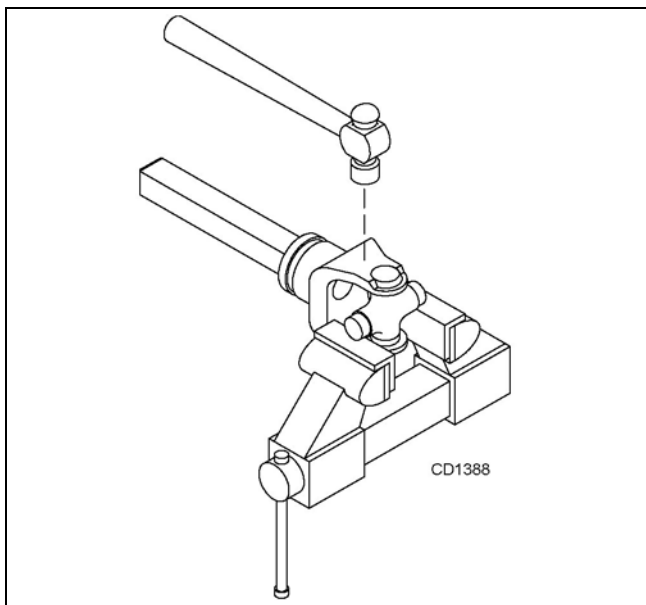
**Figure 24.** Remove Cups

2. With snap rings removed, support drive in vise, hold yoke in hand and tap on yoke to drive cup up out of yoke. See Figure 24.



**Figure 25.** Remove Cups

3. Clamp cup in vise as shown in Figure 25 and tap on yoke to completely remove cup from yoke. Repeat Step 2 and Step 3 for opposite cup.



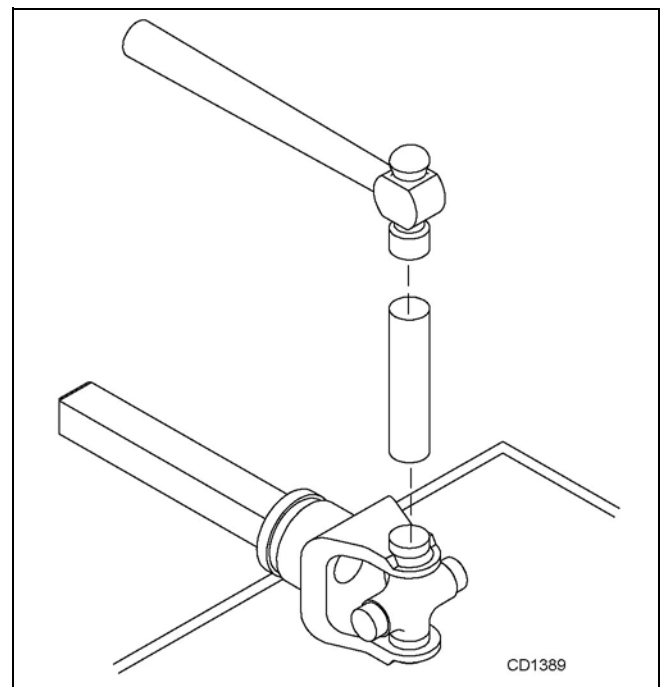
**Figure 26.** Remove Cups

4. Place universal cross in vise as shown in Figure 26 and tap on yoke to remove cup. Repeat Step 3 for

final removal. Drive remaining cup out with a drift and hammer.

## U-Joint Assembly

1. Place seals securely on bearing cups. Insert cup into yoke from outside and press in with hand pressure as far as possible. Insert journal cross into bearing cup with grease fitting away from shaft. Be careful not to disturb needle bearings. Insert another bearing cup directly across from first cup and press in as far as possible with hand pressure.
2. Trap cups in vise and apply pressure. Be sure journal cross is started into bearings and continue pressure with vise, squeezing in as far as possible. Tapping the yoke will help.
3. Seat cups by placing a drift or socket (slightly smaller than the cup) on cup and rap with a hammer. See Figure 27. Install snap ring and repeat on opposite cup
4. Repeat Step 1 and Step 2 to install remaining cups in remaining yoke.
5. Move both yokes in all directions to check for free movement. If movement is restricted, rap on yokes sharply with a hammer to relieve any tension. Repeat until both yokes move in all directions without restriction.



**Figure 27.** Install Cups

# ASSEMBLY INSTRUCTIONS

## DEALER SET-UP INSTRUCTIONS

These instructions are for the assembly of the TS1680 mounted and pull-type cutter. Many of the procedures apply to all units. When an instruction applies to a specific unit, the section heading will indicate which unit. Assembly of options may not apply to all units.

Assembly of the cutter is the responsibility of the Woods dealer. It should be delivered to the owner completely assembled, lubricated, and adjusted for normal cutting conditions.

The cutter is shipped partially assembled. Assembly will be easier if components are aligned and loosely assembled before tightening hardware. Recommended torque values for hardware are located in the Bolt Torque Chart, page 77.

Select a suitable working area. A smooth hard surface, such as concrete, will make assembly much quicker. Open parts boxes and lay out parts and hardware to make location easy. Refer to illustrations, accompanying text, parts lists and exploded view drawings.

Complete check lists on page 48 when you have completed the assembly.

## TS1680 PULL-TYPE CUTTER - REAR HALF (Figure 28)

Place jackstands under cutter to raise it off the ground to provide clearance when assembling cutter. See "BLOCKING METHOD" on page 21 for jackstand placement.

### Install Rear Tailwheel

1. Attach tailwheel arms (1) to the tailwheel using eight (four per arm) cap screws (18) and lock nuts (19).

**NOTE:** Position tailwheel arms on tailwheel to desired location (usually on row crop centers).

2. Install wheel hubs (28) to tailwheel arms using caps screw (20) and lock nut (21). Wheel hubs should be positioned to the outside of the cutter.
3. Attach solid or aircraft tires to wheel hubs using five lug nuts (29). Install the chamfered side of the lug nut toward the inside for steel rim for pneumatic tires and rims (shown).

**NOTE:** Install the flat side of the nut toward the inside for solid tires and aircraft tires.

### Install Attitude Rod

Slide attitude rod (3) under right spindle driveline and through pivot block on the tailwheel. Loosely install sleeve (4), washer (22) and two hex nuts (23).

### Install Height Adjustment Device

#### Ratchet

1. Place one end of ratchet (10) between lugs on deck and secure with pin (16) and cotter pins (17).
2. Attach opposite end of ratchet (10) between lugs (Position A) on tailwheel and secure with pin (30) and two cotter pins (17).

#### Cylinder

1. Place base end of hydraulic cylinder (6) between lugs on deck and secure with pin (16) and cotter pins (17).
2. Place hydraulic cylinder (6) between lugs (Position A) on tailwheel.
3. Extend cylinder rod, place transport lock bracket (5) over cylinder rod end and between lugs on tailwheel.
4. Align holes of cylinder rod, transport lock bracket and lugs on tailwheel. Secure assembly using pin (30) and cotter pins (17).

### Install Hydraulic Hose



- On pull-type units with optional hydraulic cutting height adjustment, use a single-acting cylinder with a maximum extended length of 28-1/4" (718 mm) from attaching point center to center.

#### **NOTICE**

- If using a cylinder other than the one supplied by Woods, make sure a breather fitting is installed in the cylinder rod end port. Use a restricter fitting in the base end port to dampen the cutter lowering action.

1. Install reducer bushing (7) and restricter elbow (8) in port at base end of cylinder (6). Position elbow to point toward front of cutter.

**NOTE:** Make sure there is a breather fitting installed in the rod end port.

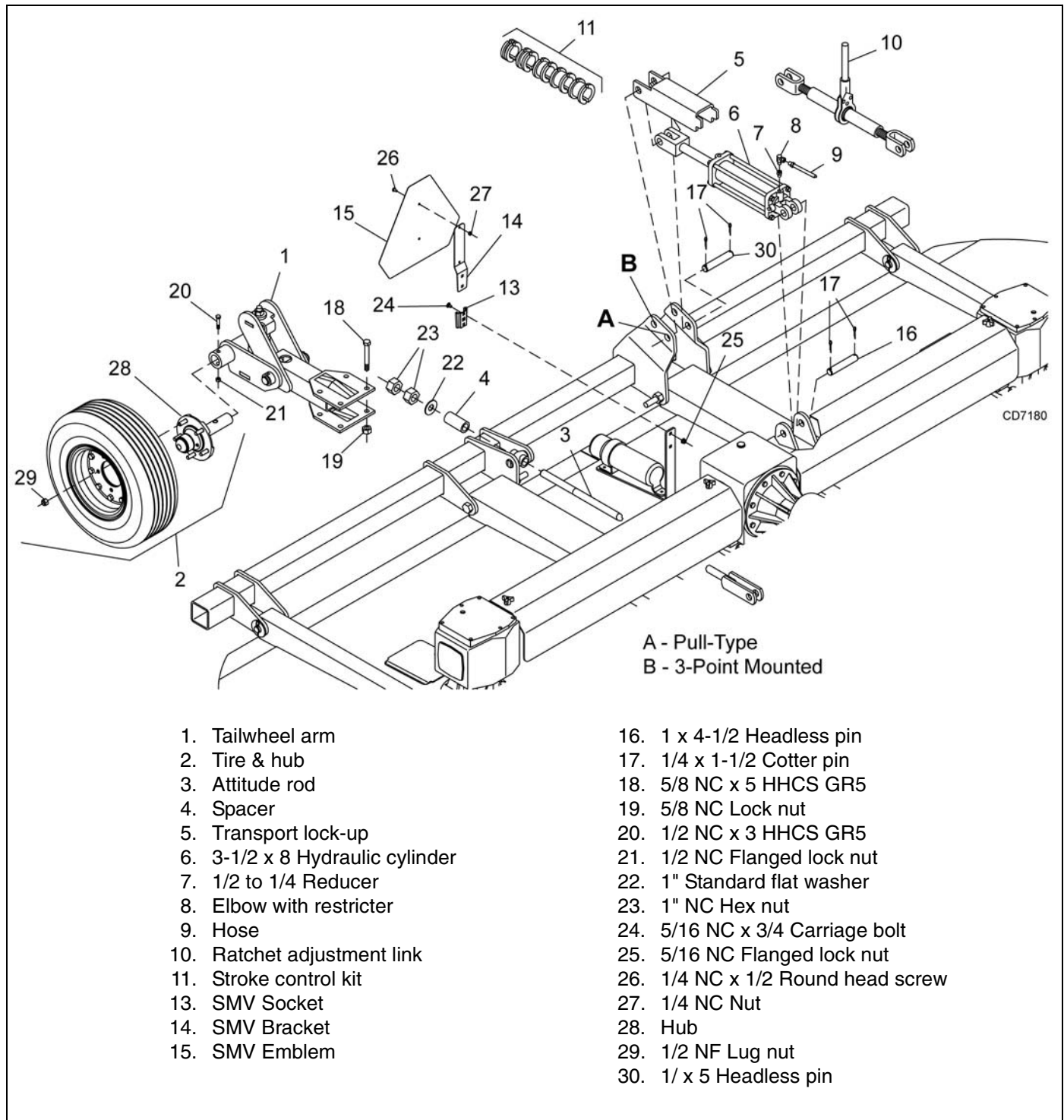
2. Connect hose (9) to elbow (8).
3. Install optional stroke control kit (11) to cylinder rod. Stroke control kit is used to set cut height.

## Install SMV Emblem

1. Attach SMV socket (13) to deck bracket with two carriage bolts (24) and lock nuts (25).

2. Attach SMV emblem (15) to SMV bracket (14) using two round head cap screws (26) and hex nuts (27).

3. Insert SMV bracket (14) and emblem (15) into socket (13).



**Figure 28.** TS1680 Pull-Type Cutter Assembly - Rear Half

## TS1680 Pull-Type Assembly (Continued)

### FRONT HALF (Figure 29)

#### Install Tongue

1. Place tongue (1) between mast plates.
2. Place washer (27) and sleeve (19) on cap screw (26).
3. Place washer (27†) between mast plates and tongue, insert cap screw (26) with washer (27†) and sleeve (19) through mast plates, tongue and washer (27†).
4. Secure with washer (27) and lock nut (28).
5. Attach front half of attitude rod (13) to lug on tongue using clevis pin (18) and cotter pin (29).
6. Raise front of cutter and install parking jack (4) to support tongue.
7. Attach safety tow chain (5) to tongue by wrapping chain around diagonal brace and threading the hook end back through the large link on opposite end of chain.

#### Install CV Driveline (Figure 29)

##### Install Driveline

1. Coat input shaft of gearbox with a light coating of grease.
2. Attach slip clutch on driveline (7) to input shaft of gearbox. Tighten cap screws (20) and lock nuts (21).

3. Attach rear tether chain on driveline to clip on plastic gearbox shield.

##### H-Frame

1. Attach H-frame mounting bracket (2) to cutter deck with carriage bolts (34), washers (35) and lock nuts (30). Attach front of bracket (2) to cutter frame with washers (36), lock washers (32) and self-tapping screws (37).
2. Place H-frame (3) over bracket and align holes.
3. Secure H-frame to bracket using cap screw (24), two sleeves (16), two cup washers (17) and lock nut (25).

##### Attach Driveline to H-Frame

**NOTE:** Select holes in H-frame that will allow driveline to run level. Refer to Operation section for driveline height. Final adjustment will be necessary when cutter is attached to the tractor.

Place driveline carrier bearing (8) between H-frame (3) and secure with clevis pin (12) and cotter pin (38).

##### Install CV Drive

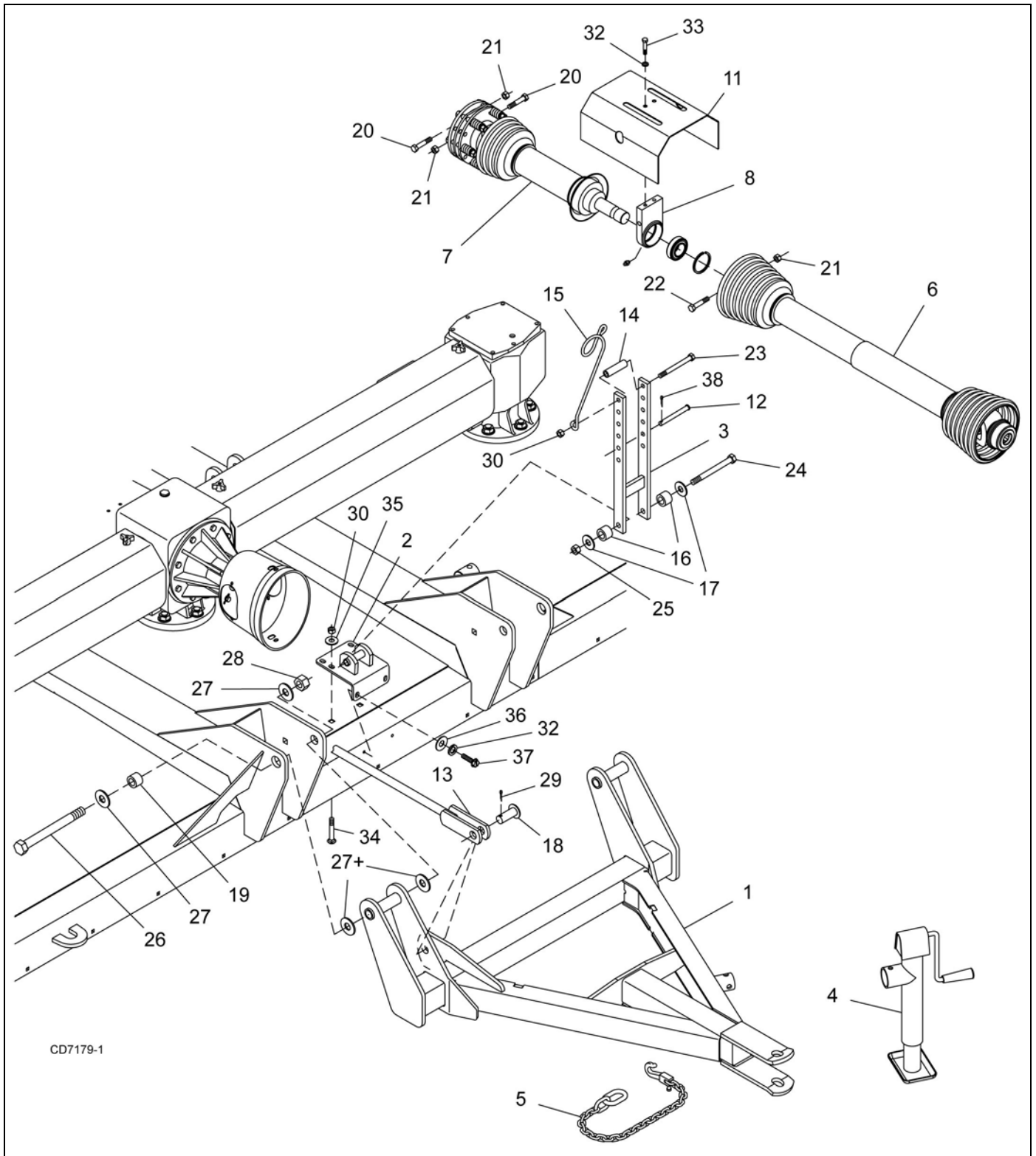
1. Slide rear yoke of CV driveline (6) over shaft of driveline (7) and align with notch on shaft.
2. Secure drives together using cap screw (22) and lock nut (21).

##### Install Drive Shield & Hose Holder

1. Attach drive shield (11) to driveline carrier bearing using two cap screws (33) and lock washers (32).
2. Attach hydraulic hose holder (15) to the top hole in H-frame (3) with cap screw (23), spacer (14) and lock nut (30).

- |                                  |                                      |
|----------------------------------|--------------------------------------|
| 1. Tongue                        | 21. 1/2 NC Lock nut                  |
| 2. CV H-frame mounting base      | 22. 1/2 NC x 2 HHCS GR5              |
| 3. H-Frame                       | 23. 1/2 NC x 5-1/2 HHCS GR5          |
| 4. Parking jack                  | 24. 5/8 NC x 6 HHCS GR5              |
| 5. Safety chain                  | 25. 5/8 NC Lock nut                  |
| 6. Front 2/3 drive               | 26. 1 NC x 9 HHCS GR5                |
| 7. Rear 1/3 drive                | 27. 1" Standard flat washer          |
| 8. 3-Joint drive bearing housing | 28. 1 NC Lock nut                    |
| 11. Shield                       | 29. 1/4 x 1-1/2 Cotter pin           |
| 12. Clevis pin, 1/2 x 5-3/4      | 30. 1/2 NC Flange lock nut           |
| 13. Attitude rod                 | 32. 3/8 Standard lock washer         |
| 14. 1/2 Schedule 40 x 3.56 pipe  | 33. 3/8 NC x 1 HHCS                  |
| 15. Hose holder                  | 34. 1/2 NC x 1-1/2 Carriage bolt GR5 |
| 16. Sleeve, 5/8 x 1 x 9/16       | 35. 1/2 Flat washer                  |
| 17. Cup washer                   | 36. 3/8 Flat washer                  |
| 18. Clevis pin, 1 x 2-1/2        | 37. 3/8 x 1-1/4 Self-tapping screw   |
| 19. Sleeve, 1.02 x 1.38 x .62    | 38. 3/16 x 1 Cotter pin              |
| 20. 1/2 NC x 3 HHCS GR5          | + As required                        |





**Figure 29.** TS1680 Pull-Type Cutter Assembly - Front Half

## **TS1680 MOUNTED CUTTER (FIGURE 30)**

Place jackstands under cutter to raise it off the ground to provide clearance when assembling cutter. See "BLOCKING METHOD" on page 21 for jackstand placement.

### **Install A-Frame**

1. Attach A-frame weldment (3) to the lower (square) hole of the cutter mast plates. Secure using carriage bolts (26), bushing sleeves (17), washers (25) and lock nuts (24).
2. Remove two lock nuts (22) from rear of cutter. Slide washer (34), rear A-frame bar (2) and second washer (34) over bolt and re-attach with lock nuts (22).
3. Attach the two rear A-frame bars (2) together at the top rear hole using cap screw (33), spacer sleeve (9) and lock nut (24).
4. Place both break links (7) together and position between front holes of rear A-frame bars. Secure rear A-frame bars and break links together using cap screw (33), spacer sleeve (9) and lock nut (24).

**NOTE:** Break links must rest on top of rear spacer sleeve (9).

5. Place spacer sleeve (8) through front holes of break links. Align break links with rear holes of A-frame weldment (3) and secure together using cap screw (30), sleeve (6) and lock nut (31).

### **Install Tailwheel Arms**

Attach tailwheel arms (1) to tailwheel using eight (four per arm) cap screws (20) and lock nuts (21).

**NOTE:** Position tailwheel arms on tailwheel to desired location (usually on row crop centers).

### **Install Height Adjustment Device**

#### **Ratchet**

1. Place one end of ratchet (16) between lugs on deck and secure with pin (18) and cotter pins (32).
2. Attach opposite end of ratchet (16) between lugs (Position B) on tailwheel and secure with pin (42) and two cotter pins (32).

### **Cylinder**

1. Place base end of hydraulic cylinder (12) between lugs on deck and secure with pin (18) and cotter pins (32).
2. Place hydraulic cylinder (12) between lugs (Position B) on tailwheel.
3. Extend cylinder rod, place transport lock bracket (11) over cylinder rod end and between lugs on tailwheel.
4. Align holes of cylinder rod, transport lock bracket and lugs on tailwheel. Secure assembly using pin (42) and cotter pins (32).

### **Install Hydraulic Hoses**



■ On mounted units with optional hydraulic cutting height adjustment, use a double-acting cylinder with a maximum extended length of 28-1/4" (718 mm) from attaching point center to center.

### **NOTICE**

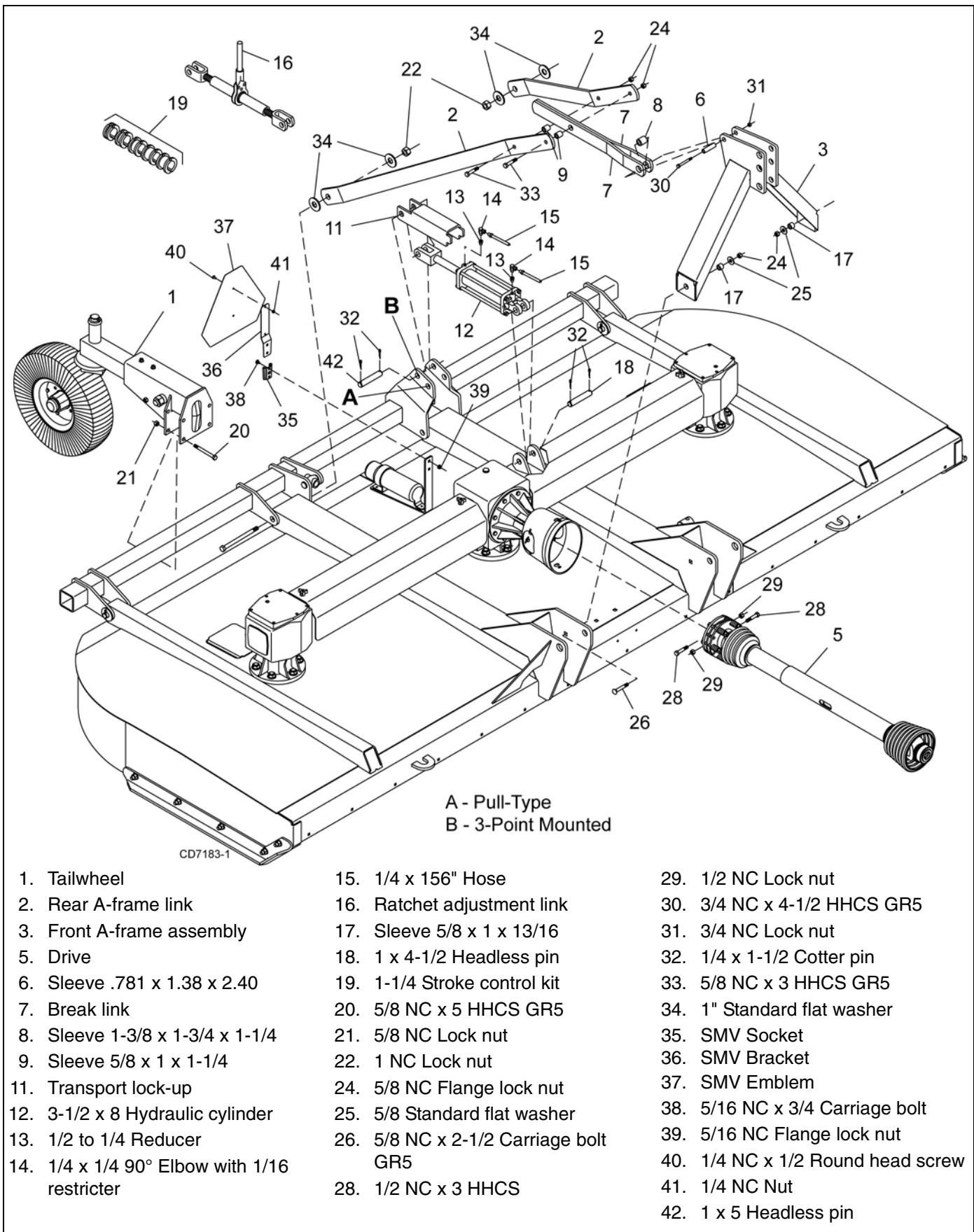
■ If using a cylinder other than the one supplied by Woods, make sure a breather fitting is installed in the cylinder rod end port. Use a restrictor fitting in the base end port to dampen the cutter lowering action.

**NOTE:** Mounted units must use a double-acting cylinder to prevent damage to tailwheels during transport.

1. Connect hoses (15) to elbows (14).
2. Install reducer bushing (13) and restrictor swivel elbow (14) in port at each end of cylinder (12). Position elbows to point toward front of cutter.
3. Install optional stroke control kit (19) to cylinder rod. Stroke control kit is used to set cut height.

### **Install Driveline**

1. Coat input shaft of gearbox with a light coating of grease.
2. Attach slip clutch on driveline (5) to input shaft of gearbox. Tighten cap screws (28) and lock nuts (29).
3. Attach rear tether chain of driveline to driveline shield.



**Figure 30. TS1680 Mounted Cutter Assembly**

## Install SMV Emblem (Semi-Mounted)

See Figure 30.

1. Attach SMV socket (35) to deck bracket with two carriage bolts (38) and lock nuts (39).
2. Attach SMV emblem (37) to SMV bracket (36) using two round head cap screws (40) and hex nuts (41).
3. Insert SMV bracket (36) and emblem (37) into socket (35).

## ALL MODELS

### FILL GEARBOXES

#### NOTICE

■ Gearbox is not filled at the factory. Prior to delivery to customer, make sure gearbox is filled only half-full with 80W or 90W API GL-4 or GL-5 gear lube. Use side plug to remove any excess oil.

### Side Gearboxes

1. Make sure vent plug hole is clear (installed by dealer).
2. Remove plug on side of gearbox
3. Fill gearbox until oil runs out the side plug on gearbox. Use a high quality gear oil with a viscosity index of 80W or 90W and an API service rating of GL-4 or GL-5.
4. Install side plug and vent plug.

### Center Gearbox

1. Make sure dipstick vent hole is clear.

2. Fill gearbox until oil level is between rings with dipstick seated. Use a high quality gear oil with a viscosity index of 80W or 90W and an API service rating of GL-4 or GL-5.
3. Install dipstick.

## INSTALL CHAIN SHIELDING (OPTIONAL)

### DANGER

■ Full chain shielding must be installed when operating in populated areas or other areas where thrown objects could injure people or damage property.

- If this machine is not equipped with full chain shielding, operation must be stopped when anyone comes within 300 feet (92 m).
- This shielding is designed to reduce the risk of thrown objects. The mower deck and protective devices cannot prevent all objects from escaping the blade enclosure in every mowing condition. It is possible for objects to ricochet and escape, traveling as much as 300 feet (92 m).

■ Full chain shielding is required for all non-agricultural mowing. Full shielding is also recommended for all agricultural use to further reduce the risk of thrown objects.

The chain shield assemblies are ready for installation when you receive them.

Install front and rear chain shielding as shown using carriage bolts (9) and lock nuts (10).

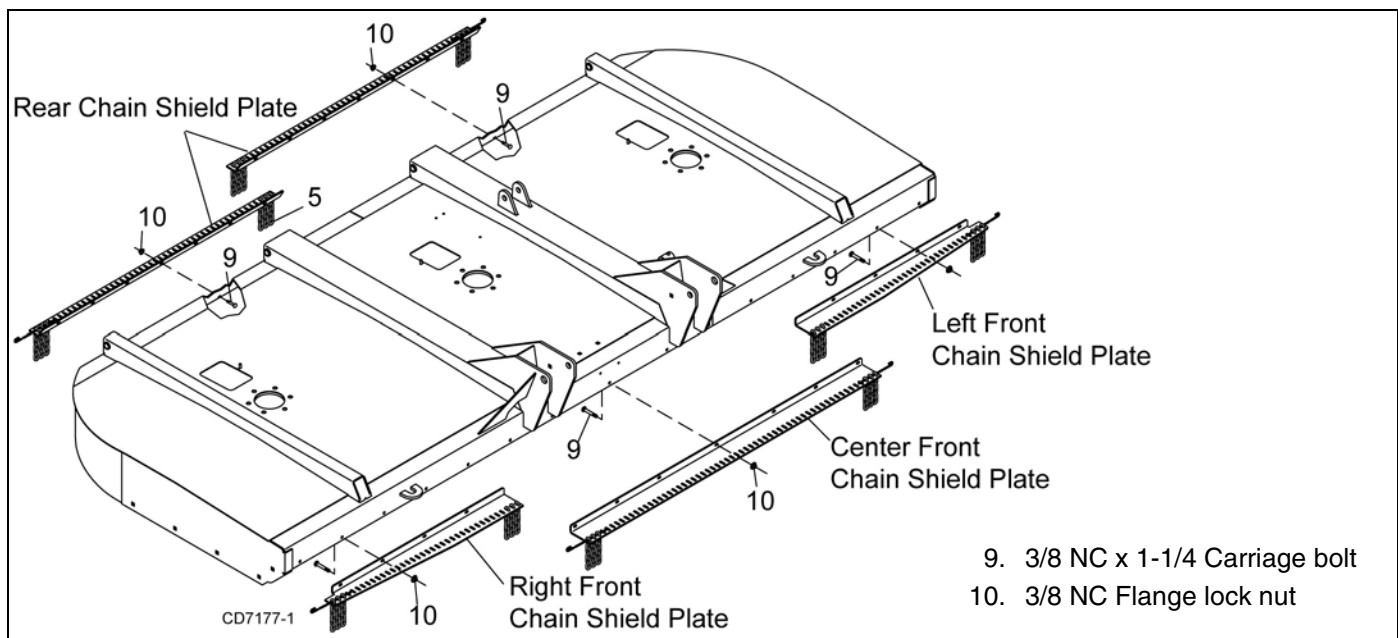
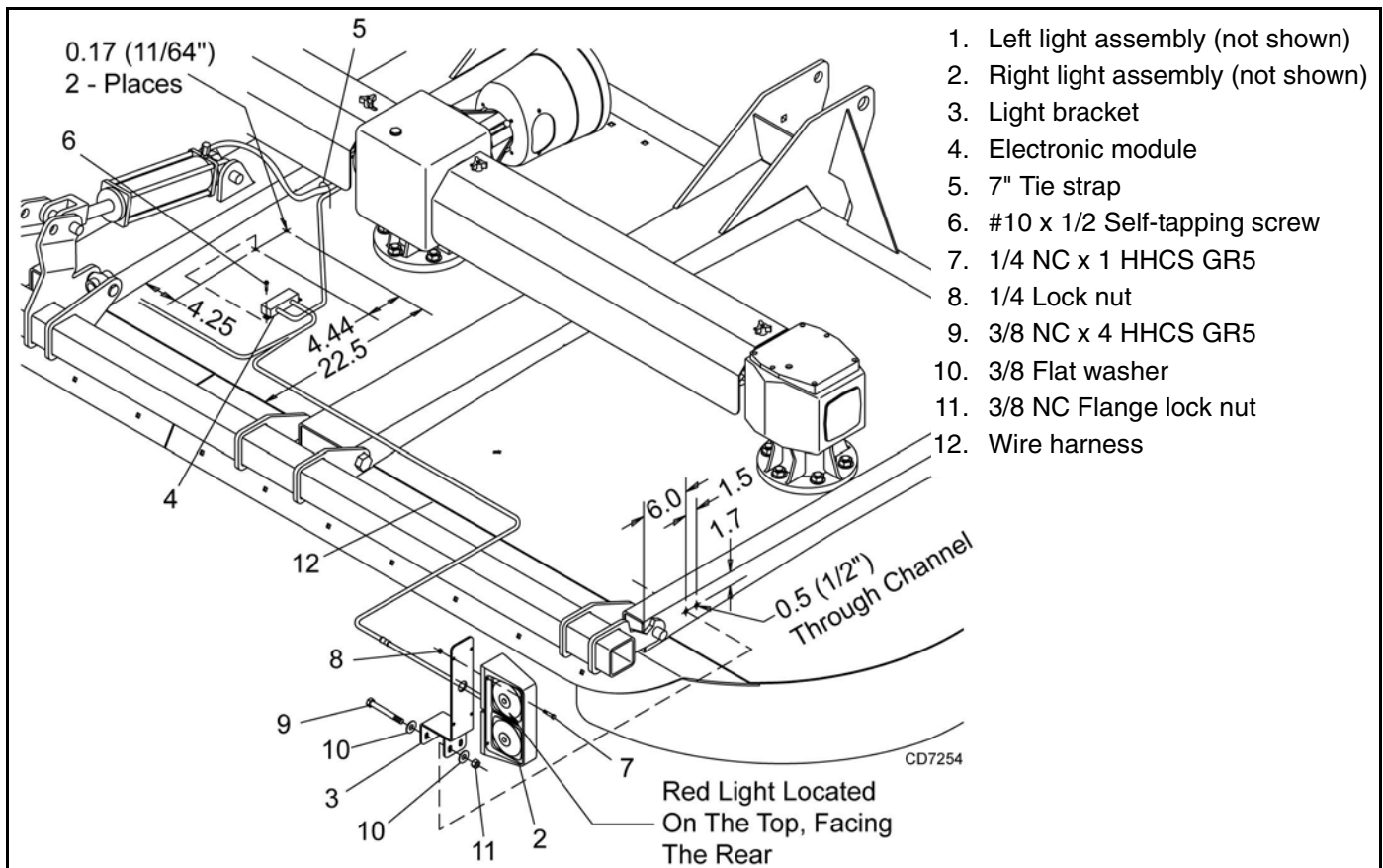


Figure 31. TS1680 Chain Shielding Installation



**Figure 32.** Light Kit Installation

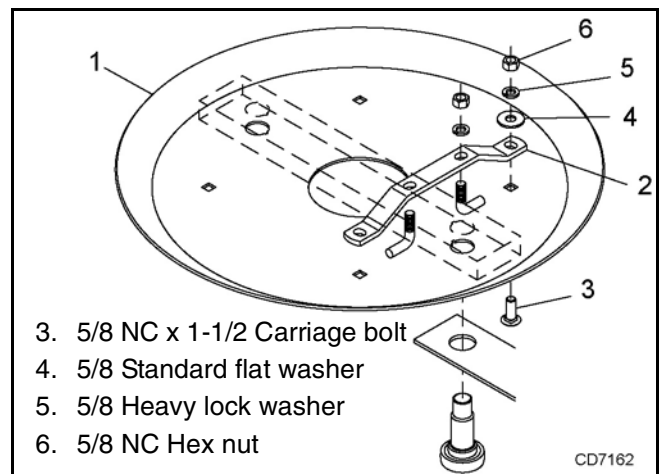
**INSTALL LIGHT KIT (OPTIONAL)**

1. Drill two 1/2" holes through both outer deck channels using dimensions shown in Figure 32.
2. Drill two 11/64" holes into deck plate as shown.
3. Install electronic module (4) to deck using self tapping screws (6).
4. Route wires as shown. Be sure wire labeled "Left" is routed to the left light.
5. Install light brackets (3) on outer deck rails as shown. Secure with cap screws (9), washers (10) and lock nuts (11).
6. Secure left and right lamp (1 & 2) to brackets (3) using cap screws (7) and lock nuts (8) as shown.
7. Connect lights to wire harness (4).
8. Route main wire along hydraulic hose and secure to hose using wire ties (5).

3. Insert blade pin through blade, stump jumper (1) and crossbar. Reinstall spacer on blade pin and install new jam nut.
4. Attach straps (2) to stump jumper (1) and crossbar using carriage bolts (3), washers (4), lock washers (5) and hex nuts (6).

**INSTALL STUMP JUMPER (OPTIONAL)**

1. Remove blade pins and blades from crossbar.
2. Remove straps (2) from stump jumper (1).



**Figure 33.** Stump Jumper Assembly

## **INSTALL SHREDDER KIT (OPTIONAL)**

1. Remove nut (9) and spacer (10) from blade pin (11). While keeping the lower formed blade installed, install double-edge blade (2) with offset upwards towards deck.
2. Reinstall spacer (10). Install new nut (9) and torque to 664 lbs-ft. Make sure blades are free to pivot.
3. Install blade holder (1) to link between rear V-baffle of machine using four cap screws (7) and four lock nuts (8).

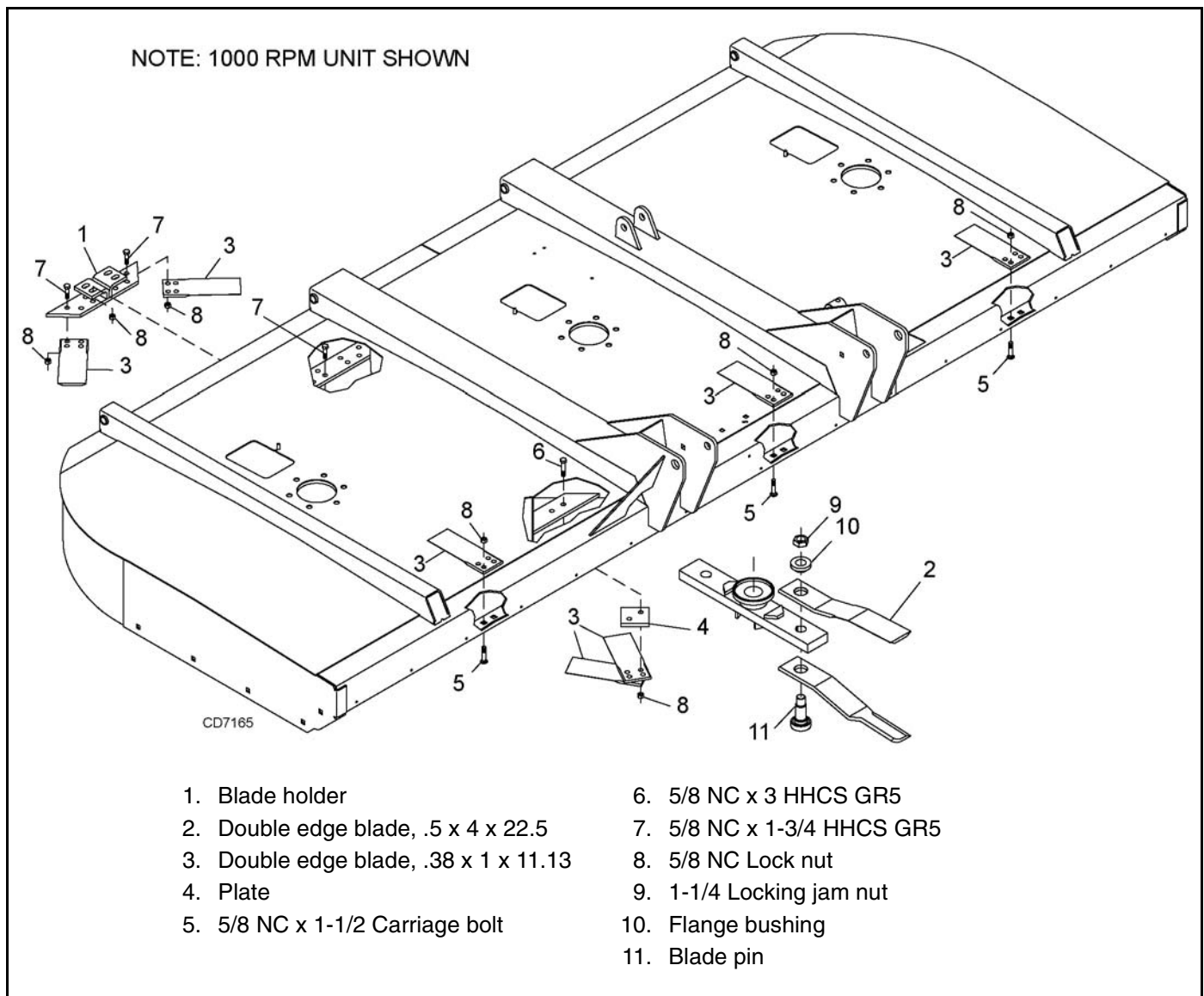
**NOTE:** Blade holder installs on right side of cutter for 1000 rpm cutters (shown) and on the left side for 540 rpm cutters. See Figure 35.

4. Attach two stationary blades (3) to blade holder using cap screws (7) and lock nuts (8).
5. Attach plate (4) and two stationary blades (3) to link between front V-baffle of machine using cap screws (6) and lock nuts (8).

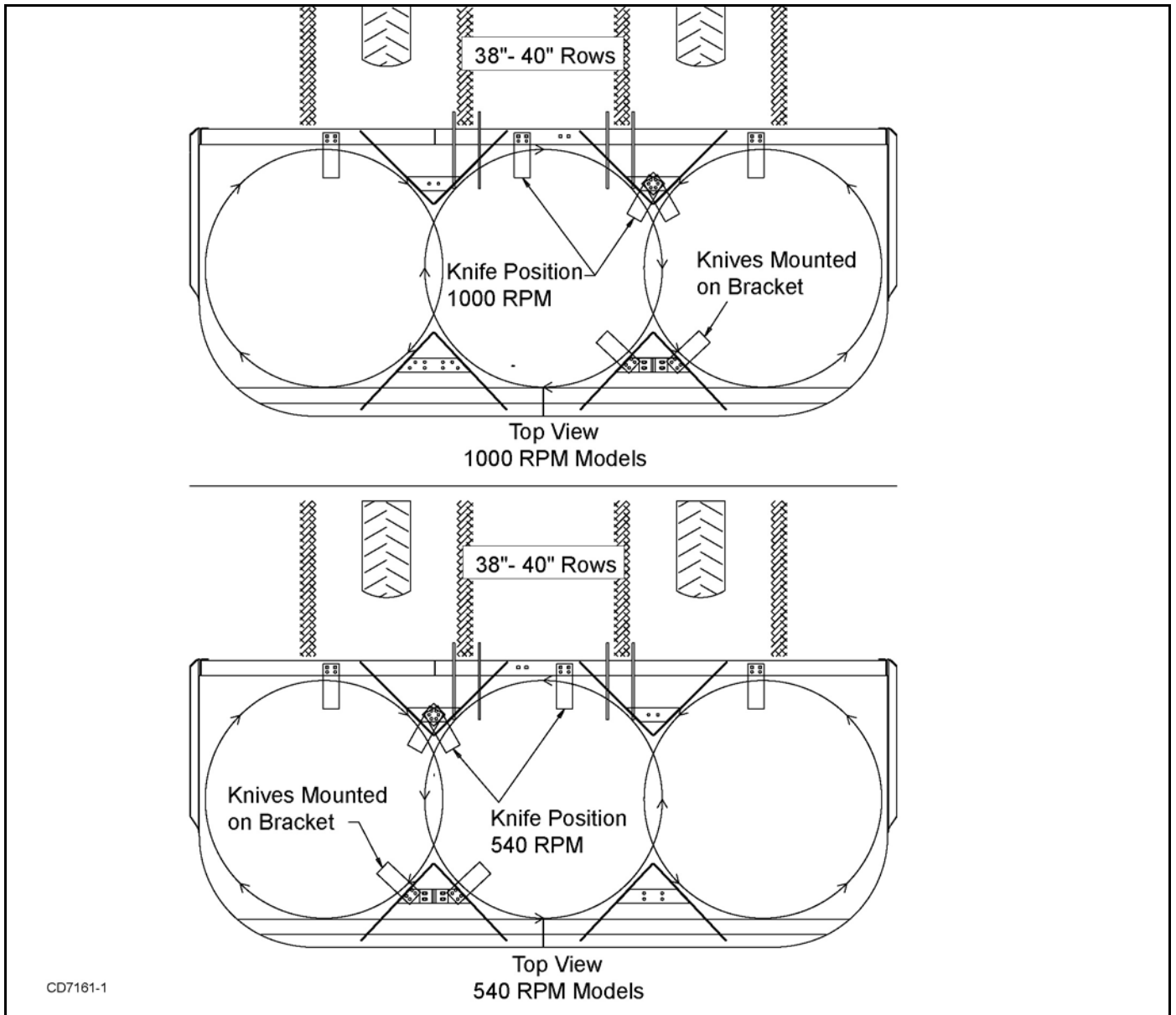
**NOTE:** Blades located on right side of cutter for 1000 rpm cutters (shown) and on the left side for 540 rpm cutters.

6. Attach three stationary blades (3) to front frame of cutter using carriage bolts (5) and lock nuts (8).

**NOTE:** Center blade is located left of cutter center for 1000 rpm cutters (shown) and right of center for 540 rpm cutters.



**Figure 34.** Shredder Kit Installation



**Figure 35.** Stationary Blade Positions for 1000 RPM and 540 RPM Models

# DEALER CHECK LISTS

## PRE-DELIVERY CHECK LIST

(DEALER'S RESPONSIBILITY)

Inspect cutter thoroughly after assembly to make sure it is set up properly before delivering it to the customer. The following check list is a reminder of points to inspect. Check off each item as it is found satisfactory, corrections are made, or services are performed.

### **NOTICE**

■ **Gearbox was not filled at the factory. It must be serviced before operating cutter. (See LUBRICATION, page 21). Failure to service will result in damage to gearbox.**

- \_\_\_ Check that gearbox is properly serviced and seals are not leaking.
- \_\_\_ Check and grease all lubrication points as identified in **Owner Service**, LUBRICATION, page 21.
- \_\_\_ Check that blades have been properly installed
- \_\_\_ Check all bolts to be sure they are properly torqued.
- \_\_\_ Check that all cotter pins are properly installed and secured.
- \_\_\_ Check that PTO shaft is properly installed.

## DELIVERY CHECK LIST

(DEALER'S RESPONSIBILITY)

- \_\_\_ Show customer how to make adjustments. Describe the options available for this cutter and explain their purpose.
- \_\_\_ Explain importance of lubrication to customer and point out lubrication points on cutter.
- \_\_\_ Point out all guards and shielding. Explain their importance and the safety hazards that exist when not kept in place and in good condition.
- \_\_\_ For mounted units, add wheel weights, ballast in front tires, and/or front tractor weight to enhance front end stability. A minimum 20% of tractor and equipment gross weight must be on front tractor wheels. When adding weight to attain 20% of tractor and equipment weight on front tractor wheels, you must not exceed the ROPS weight certification. Weigh the tractor and equipment. Do not estimate!
- \_\_\_ Present Operator's Manual and request that customer and all operators read it before operating equipment. Point out the manual safety rules, explain their meanings and emphasize the increased safety hazards that exist when safety rules are not followed.
- \_\_\_ Explain to customer that when equipment is transported on a road or highway, safety devices should be used to give adequate warning to operators of other vehicles.





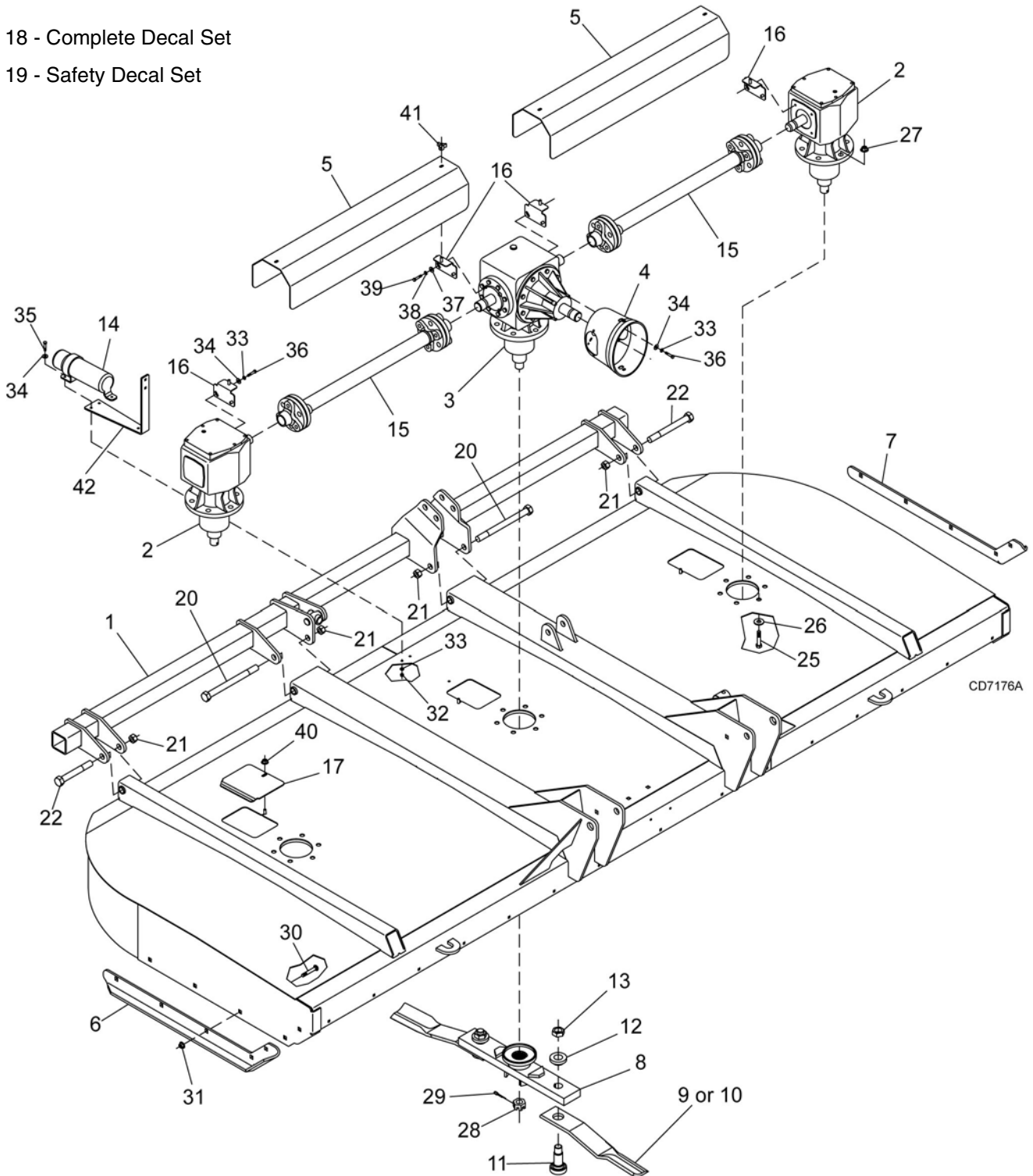
## TS1680 Rotary Cutter

MAIN FRAME ASSEMBLY .....	50 - 51
PULL-TYPE ASSEMBLY	
FRONT HALF .....	52 - 53
REAR HALF .....	54
MOUNTED CUTTER ASSEMBLY .....	56 - 57
GEARBOXES	
CENTER GEARBOX ASSEMBLY .....	58 - 59
SIDE GEARBOX ASSEMBLY .....	60 - 61
DRIVES	
540 RPM FRONT CV DRIVE ASSEMBLY .....	62 - 63
1000 RPM FRONT CV DRIVE ASSEMBLY .....	64 - 65
REAR FIXED-LENGTH DRIVE FOR CV DRIVE .....	66
SLIP CLUTCH DRIVE ASSEMBLY, MOUNTED .....	67
FLEXIBLE COUPLER .....	68
WHEELS & TAILWHEELS	
WHEEL & TIRE ASSEMBLY .....	55
TAILWHEEL ASSEMBLIES	
SPRING WHEEL ARM ASSEMBLY, PULL-TYPE .....	69
CASTER ARM ASSEMBLY, MOUNTED .....	70 - 71
CHAIN SHIELDING (OPTIONAL) .....	72
LIGHT KIT (OPTIONAL) .....	73
STUMP JUMPER ASSEMBLY (OPTIONAL) .....	73
SHREDDER KIT (OPTIONAL) .....	74
3-1/2 X 8" STROKE HYDRAULIC CYLINDER (OPTIONAL) .....	75
HYDRAULIC CYLINDER STROKE CONTROL KIT (OPTIONAL) .....	76
CROSSBAR PULLER (OPTIONAL) .....	76

# MAIN FRAME ASSEMBLY

18 - Complete Decal Set

19 - Safety Decal Set



**50 Parts**

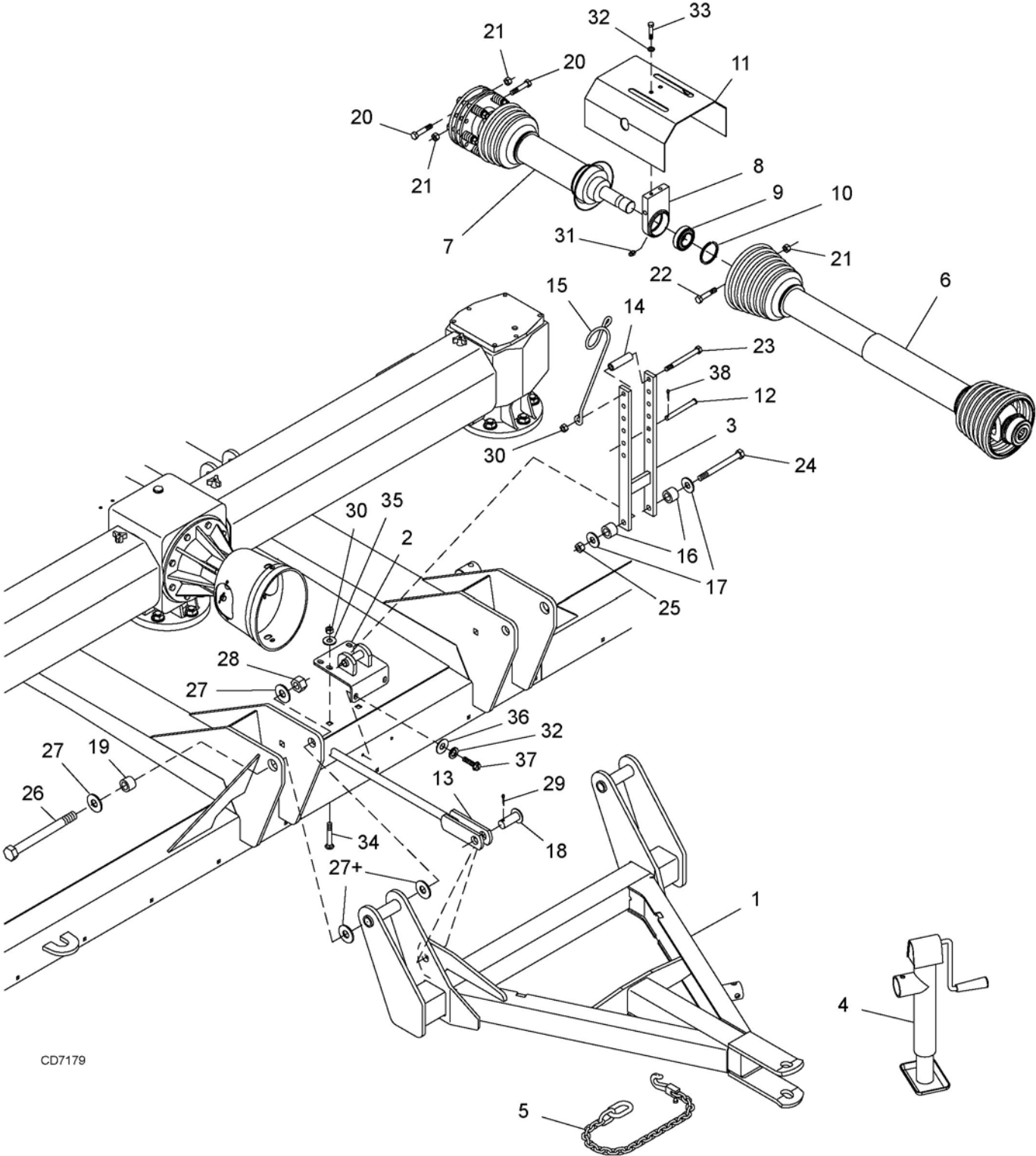
(Rev. 1/25/2008)  
MAN0577 (6/29/2007)

## MAIN FRAME ASSEMBLY

REF	PART	QTY	DESCRIPTION	REF	PART	QTY	DESCRIPTION
1	1021420	1	Tailwheel weldment	18	1024798	1	Complete decal set
2	1024795	2	Outer gearbox - 540 RPM ( <b>page 60</b> ) <b>-or-</b>	19	1024799	1	Safety decal set
2	1024797	2	Outer gearbox - 1000 RPM ( <b>page 60</b> )	20	39141	2	1 NC x 12 HHCS GR5
3	1024794	1	Center gearbox - 540 RPM ( <b>page 58</b> ) <b>-or-</b>	21	34279	4	1 NC Lock nut
3	1024796	1	Center gearbox - 1000 RPM ( <b>page 58</b> )	22	1003606	2	1 NC x 6 HHCS GR5
4	1002048	1	Clutch shield	23	1863	*	1" Standard flat washer
5	1021437	2	Shield	25	30068	*	3/4 NC x 2-1/2 HHCS GR5
6	57118	1	Right skid	26	57798		3/4 Hardened flat washer
7	57119	1	Left skid	27	302207		3/4 NC Flange lock nut
8	1021410	3	Crossbar	28	57308		M36 x 3 Castle nut
9	39002KT	2 or 4	Left blade CW; Center blade ( <b>540 RPM</b> ) ( <b>1000 RPM</b> )	29	6185	*	1/4 x 2-1/4 Cotter pin
10	39003KT	4 or 2	Right blade CCW; Center blade ( <b>540 RPM</b> ) ( <b>1000 RPM</b> )	30	5607	*	5/8 NC x 1-1/2 Carriage bolt GR5
11	39069	6	Blade pin	31	19025		5/8 NC Flanged lock nut
12	39127	6	Flanged bushing, 1.5 x 1.87 x 1.04	32	4529	*	5/16 NC Hex nut
13	39128	6	1-1/4 - 12 Jam lock nut	33	2472	*	5/16 Lock washer
14	1003828	1	Manual tube	34	35155	*	5/16 Flat washer
15	1021423	2	Flexible drive coupler ( <b>see page 68</b> )	35	6250	*	5/16 NC x 1-1/4 HHCS GR5
16	1021371	4	Shield hold down	36	39254		M8 x 1.26P x 14 mm HHCS
17	57050	3	Blade access cover	37	565	*	3/8 Flat washer
				38	5664	*	3/8 Lock washer
				39	63716		M10 x 1.50P x 20 mm HHCS
				40	14350	*	3/8 NC Flange lock nut
				41	66840		3-Prong knob, 3/8 NC
				42	1021369	1	SMV Mounting bracket

HHCS Hex Head Cap Screw  
 \* Standard hardware, obtain locally

# PULL-TYPE ASSEMBLY - FRONT HALF



CD7179

**52 Parts**

MAN0577 (6/29/2007)

## PULL-TYPE ASSEMBLY - FRONT HALF

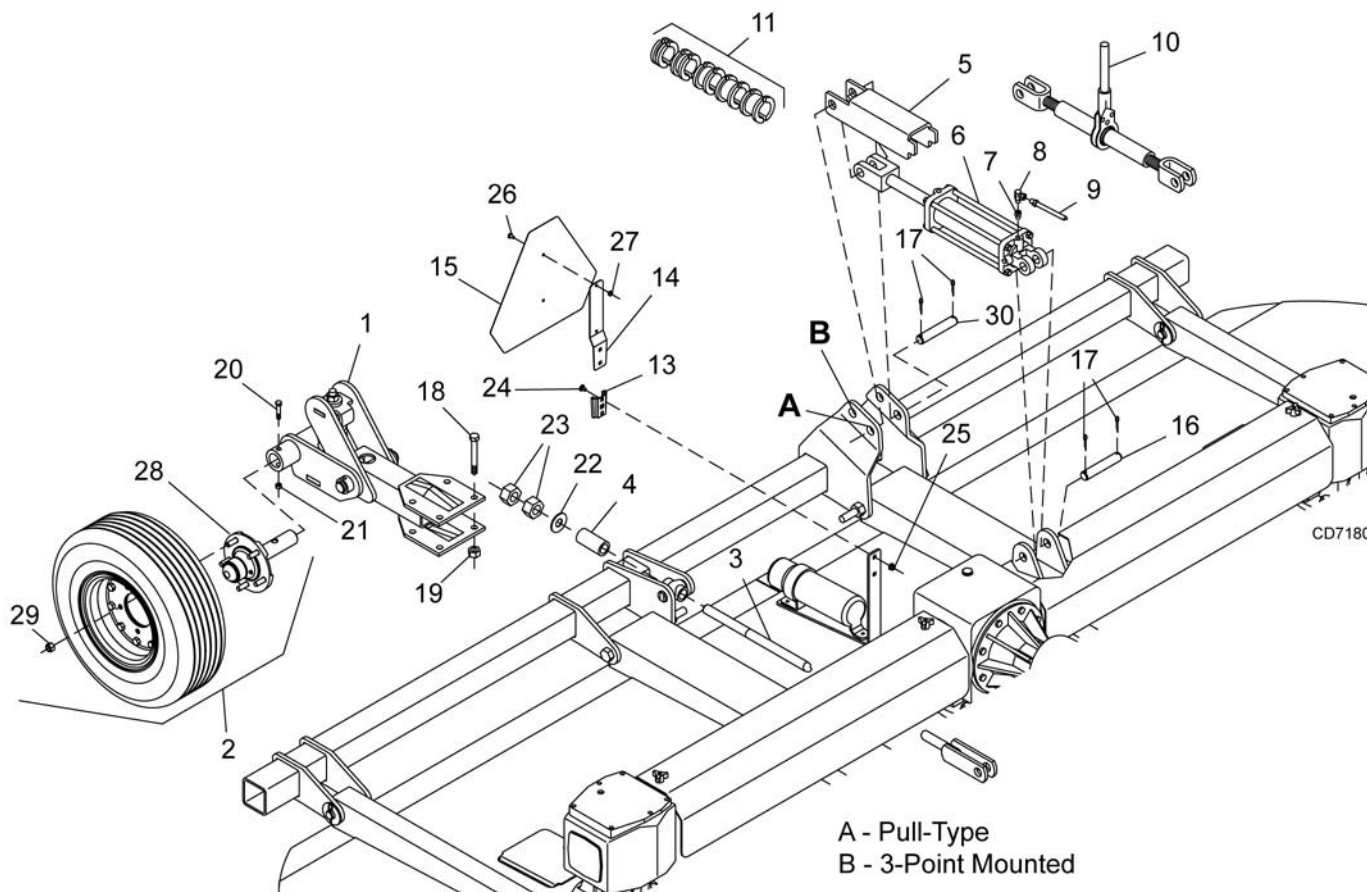
REF	PART	QTY	DESCRIPTION	REF	PART	QTY	DESCRIPTION
1	1026245	1	Tongue	18	445	1	Clevis pin, 1 x 2-1/2
2	1021377	1	CV H-frame mounting base	19	39070	2	Sleeve, 1.02 x 1.38 x .62
3	1021452	1	H-Frame	20	3489	*	1/2 NC x 3 HHCS GR5
4	23790	1	Parking jack	21	765	*	1/2 NC Lock nut
5	19407	1	Safety chain	22	3699	*	1/2 NC x 2 HHCS GR5
6	1024175	1	CV Drive assembly - 540 RPM (see page 62) -or-	23	12305	*	1/2 NC x 5-1/2 HHCS GR5
6	1021102	1	CV Drive assembly - 1000 RPM, 21 spline (see page 64) -or-	24	12005		5/8 NC x 6 HHCS GR5
6	1021101	1	CV Drive assembly - 1000 RPM, 20 spline (see page 64) -or-	25	6239	*	5/8 NC Lock nut
7	1022223	1	Rear stub shaft (see page 66)	26	15087		1 NC x 9 HHCS GR5
8	32347	1	3-joint drive bearing housing (includes items 9, 10, 31)	27	1863 +	*	1" Standard flat washer
9	13133	1	Bearing	28	34279		1 NC Lock nut
10	12128	1	Snap ring	29	1285	*	1/4 x 1-1/2 Cotter pin
11	1011761	1	Shield	30	11900	*	1/2 NC Flange lock nut
12	404	1	Clevis pin, 1/2 x 5-3/4	31	2985	*	1/4-28 x 90 Grease fitting
13	39385	1	Attitude rod	32	838	*	3/8 Standard lock washer
14	7035	1	1/2 Schedule 40 x 3.56 pipe	33	839	*	3/8 NC x 1 HHCS GR5
15	3443	1	Hose holder	34	29893	*	1/2 NC x 1-1/2 Carriage bolt GR5
16	1791	2	Sleeve, 5/8 x 1 x 9/16	35	854	*	1/2 Flat washer
17	10635	2	Cup washer 5/8 x 1-3/4 x 14 ga	36	565	*	3/8 Flat washer
				37	19446	*	3/8 x 1-1/4 Type T self-tapping screw
				38	1256	*	3/16 x 1 Cotter pin

+ As required

HHCS Hex Head Cap Screw

\* Standard hardware, obtain locally

## PULL-TYPE ASSEMBLY - REAR HALF



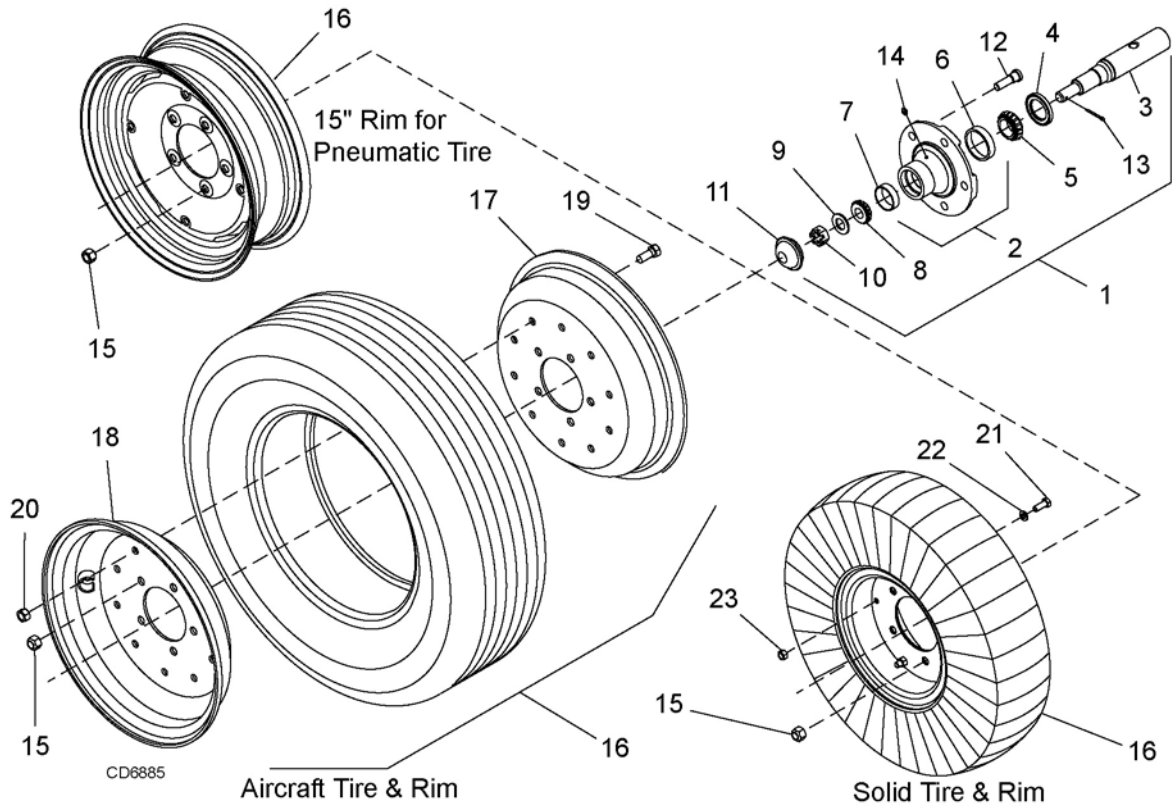
REF	PART	QTY	DESCRIPTION	REF	PART	QTY	DESCRIPTION
1	----	2	Spring wheel arm (see page 69)	16	8346	1	1 x 4-1/2 Headless pin
2	----	2 or 4	Tire & hub (see page 55)	17	1285	*	1/4 x 1-1/2 Cotter pin
3	39385	1	Attitude rod	18	378	*	5/8 NC x 5 HHCS GR5
4	11275	1	1" Schedule 40 pipe x 2.38	19	6239	*	5/8 NC Lock nut
5	1004814	1	Transport lock-up	20	3489	*	1/2 NC x 3 HHCS GR5
6	10475	1	3-1/2 x 8 Hydraulic cylinder (see page 75)	21	11900	*	1/2 NC Flange lock nut
7	11893	1	1/2 to 1/4 Reducer	22	1863	*	1" Standard flat washer
8	10290	1	1/4 x 1/4 90° Elbow w/ 1/16 restricter	23	3132	*	1 NC Hex nut
9	8669	1	1/4 x 156" Hose	24	16148	*	5/16 NC x 3/4 Carriage bolt
10	1005020	1	Ratchet adjustment link	25	14139	*	5/16 NC Flange lock nut
11	24098	1	1-1/4 Stroke control kit (see page 76)	26	1282	*	1/4 NC x 1/2 Round head screw
13	62484	1	SMV Socket	27	5288	*	1/4 NC Nut
14	1004251	1	SMV Bracket	28	----		Wheel hub ( See page 55)
15	24611	1	Slow moving vehicle emblem	29	35317	5	Nut, lug 1/2 NF
				30	8347	1	1 x 5 Headless pin

HHCS Hex Head Cap Screw  
 \* Standard hardware, obtain locally

# 54 Parts

(Rev. 1/25/2008)  
 MAN0577 (6/29/2007)

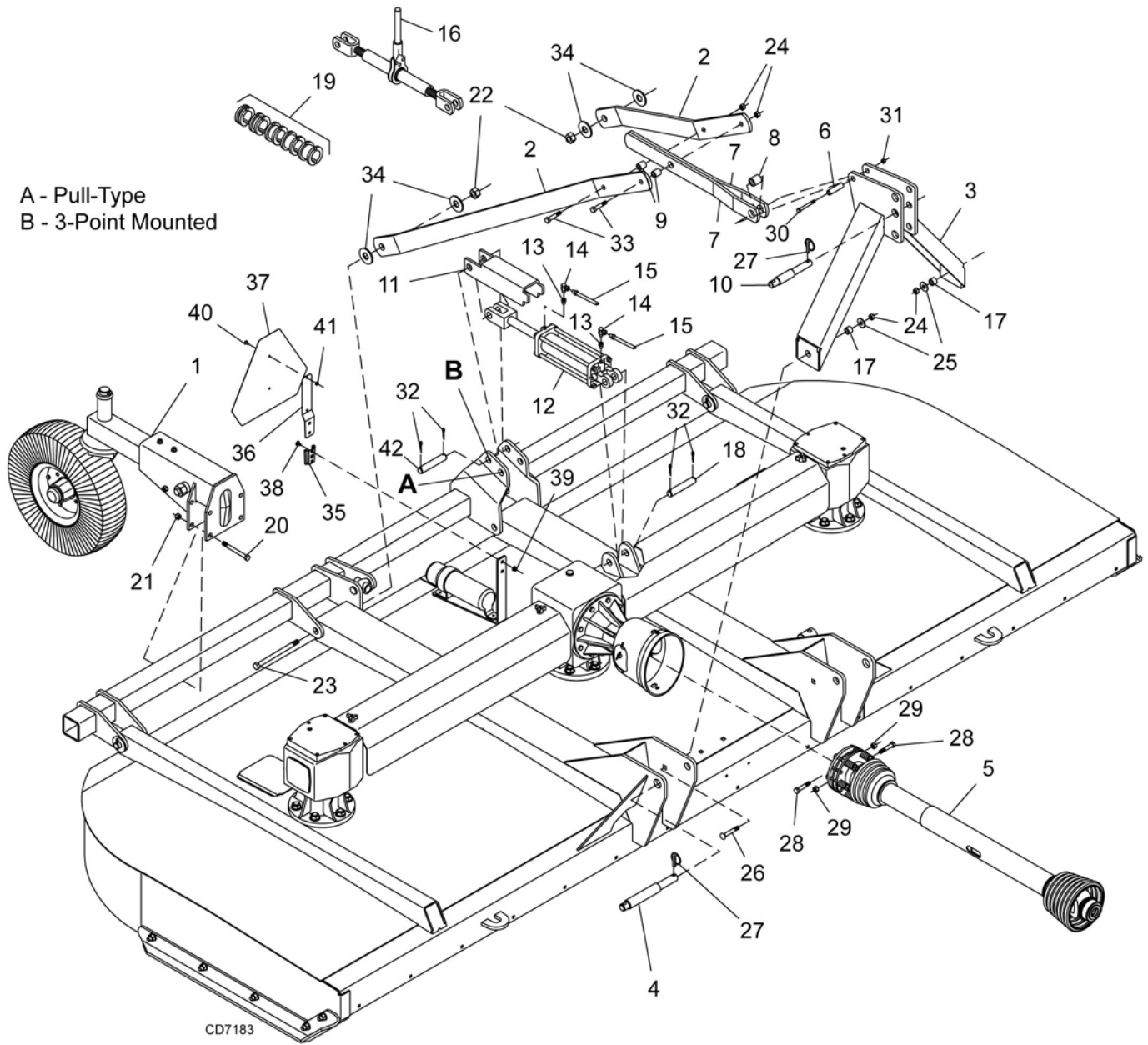
## WHEEL & TIRE ASSEMBLY



REF	PART	QTY	DESCRIPTION	REF	PART	QTY	DESCRIPTION
1	1017050	1	Heavy hub assembly (includes items 1 through 15)	16	1017080F	1	22 x 6.6 x 10 Aircraft tire, rim & hardware, foam filled - 5 bolt <b>-or-</b>
2	1017034	1	Heavy wheel hub with cups (includes items 6, 7, 14)	16	1017030	1	29 x 9 x 15 Aircraft tire, rim & hardware - 5 bolt
3	1017033	1	Axle	17	1017081	1	10.0 x 5.5 Rim half (for 22" aircraft wheel only) <b>-or-</b>
4	1017027	1	Seal	17	1017026	1	15.0 x 6.0 Rim half (for 29" aircraft wheel only)
5	1017028	1	Bearing cone	18	1017082	1	10.0 x 5.5 Rim half w/ valve hole (for 22" aircraft wheel only) <b>-or-</b>
6	1017036	1	Bearing cup	18	1017025	1	15.0 x 6.0 Rim half w/ valve hole (for 29" aircraft wheel only)
7	1017037	1	Bearing cup	19	6100 *		1/2 NC x 1-1/4 HHCS GR5
8	1017029	1	Bearing cone	20	765 *		1/2 NC Locknut
9	1017031	1	Washer	21	19887 *		3/8 NC x 1 HHCS GR8
10	1017032	1	Castle nut	22	838 *		3/8 Standard lock washer
11	1017035	1	Hub cap	23	835 *		3/8 NC Hex nut
12	1017038	5	Stud	-	1015834	1	22 x 6.6 x 10 Inner tube (for 22" aircraft wheel only)
13	1017069	1	Cotter pin	-	1015833	1	29 x 9 x 15 Inner tube (for 29" aircraft wheel only)
14	1017067	1	Grease fitting	-	1017042	2	Rim half for 6 x 9 solid tire
15	35317	5	Nut, lug 1/2 NF				
16	1017088	1	15" Rim for pneumatic tire - 5 bolt <b>-or-</b>				
16	1017040	1	6.00 x 9 Solid tire, rim & hardware - 5 bolt <b>-or-</b>				
16	1017080	1	22 x 6.6 x 10 Aircraft tire, rim & hardware - 5 bolt <b>-or-</b>				

HHCS Hex Head Cap Screw  
\* Standard hardware, obtain locally

# MOUNTED CUTTER ASSEMBLY



**56 Parts**

(Rev. 1/25/2008)  
MAN0577 (6/29/2007)



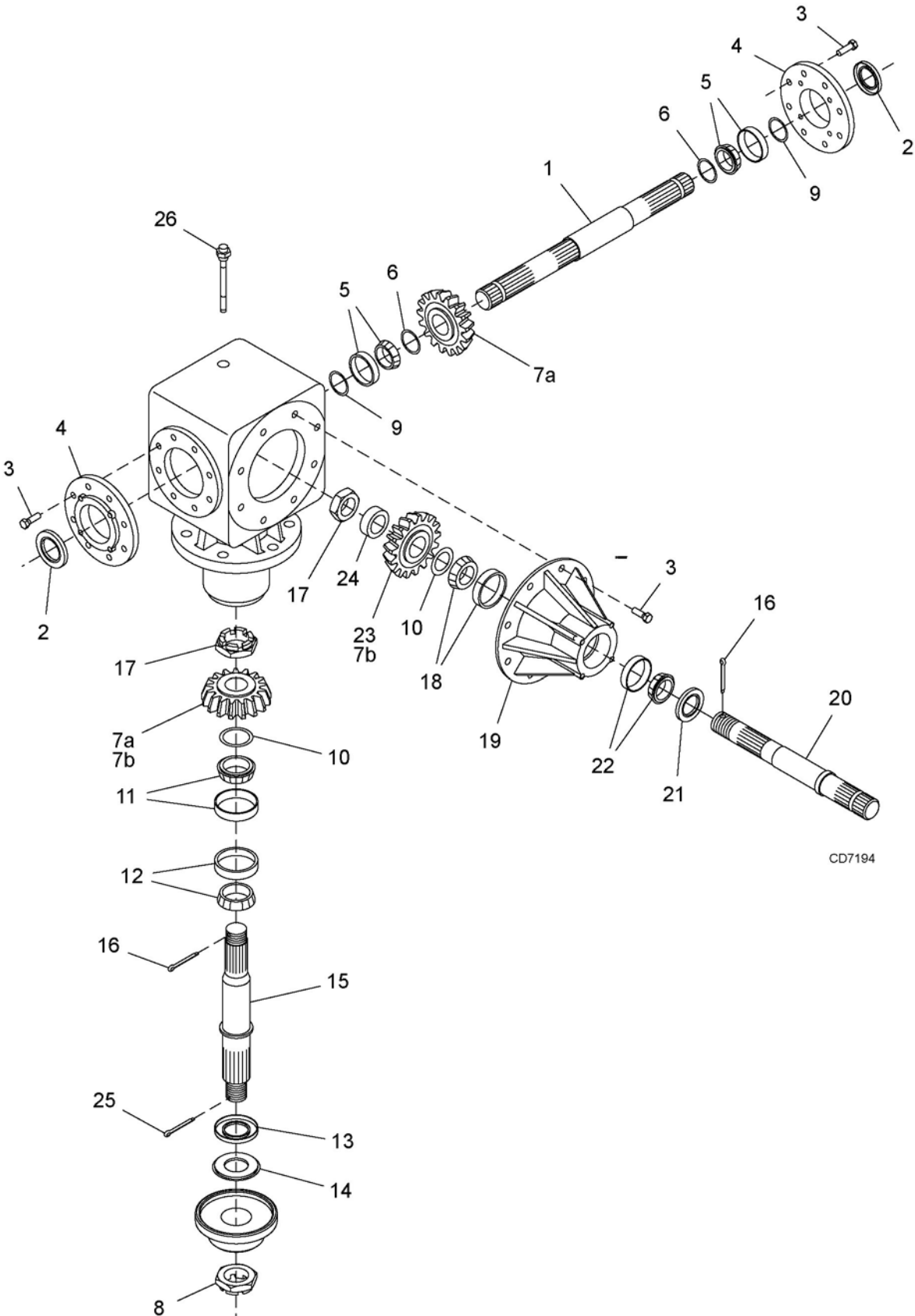
## MOUNTED CUTTER ASSEMBLY

REF	PART	QTY	DESCRIPTION	REF	PART	QTY	DESCRIPTION
1	----	2	Tailwheel ( <b>see page 70</b> )	21	6239	*	5/8 NC Lock nut
2	1021438	2	Rear A-frame link	22	34279		1 NC Lock nut
3	1021350	1	Front A-frame assembly	23	39141		1 NC x 12 HHCS GR5
4	39064	2	Lower hitch pin	24	19025	*	5/8 NC Flange lock nut
5	57419	1	Drive 540 RPM ( <b>see page 67</b> )	25	692	*	5/8 Standard flat washer
5	57290	1	Drive 1000 RPM ( <b>see page 67</b> )	26	5836	*	5/8 NC x 2-1/2 Carriage bolt GR5
6	39071	1	Sleeve .781 x 1.38 x 2.40	27	35124	*	7/16 x 2 Klik pin
7	1024792	2	Break link	28	3489	*	1/2 NC x 3 HHCS GR5
8	7176	1	Sleeve 1-3/8 x 1-3/4 x 1-1/4	29	765	*	1/2 NC Lock nut
9	66661	2	Sleeve 5/8 x 1 x 1-1/4	30	12558	*	3/4 NC x 4-1/2 HHCS GR5
10	39065	1	Top link pin	31	2371	*	3/4 NC Lock nut
11	1004814	1	Transport lock-up	32	1285	*	1/4 x 1-1/2 Cotter pin
12	18725	1	3-1/2 x 8 Hydraulic cylinder ( <b>see page 75</b> )	33	34473	*	5/8 NC x 3 HHCS GR5
13	11893	2	1/2 to 1/4 Reducer	34	1863	*	1" Standard flat washer
14	10290	2	1/4 x 1/4 90° Elbow w/ 1/16 restricter	35	62484	1	SMV Socket
15	8669	2	1/4 x 156" Hose	36	1004251	1	SMV Bracket
16	1005020	1	Ratchet adjustment link	37	24611	1	Slow Moving Vehicle emblem
17	12313	2	Sleeve 5/8 x 1 x 13/16	38	16148	*	5/16 NC x 3/4 Carriage bolt
18	8346	1	1 x 4-1/2 Headless pin	39	14139	*	5/16 NC Flange lock nut
19	24098	1	1-1/4 Stroke control kit ( <b>see page 76</b> )	40	1282	*	1/4 NC x 1/2 Round head screw
20	378	*	5/8 NC x 5 HHCS GR5	41	5288	*	1/4 NC Nut
				42	8347	1	1 x 5 Headless pin

HHCS Hex Head Cap Screw

\* Standard hardware, obtain locally

# CENTER GEARBOX ASSEMBLY

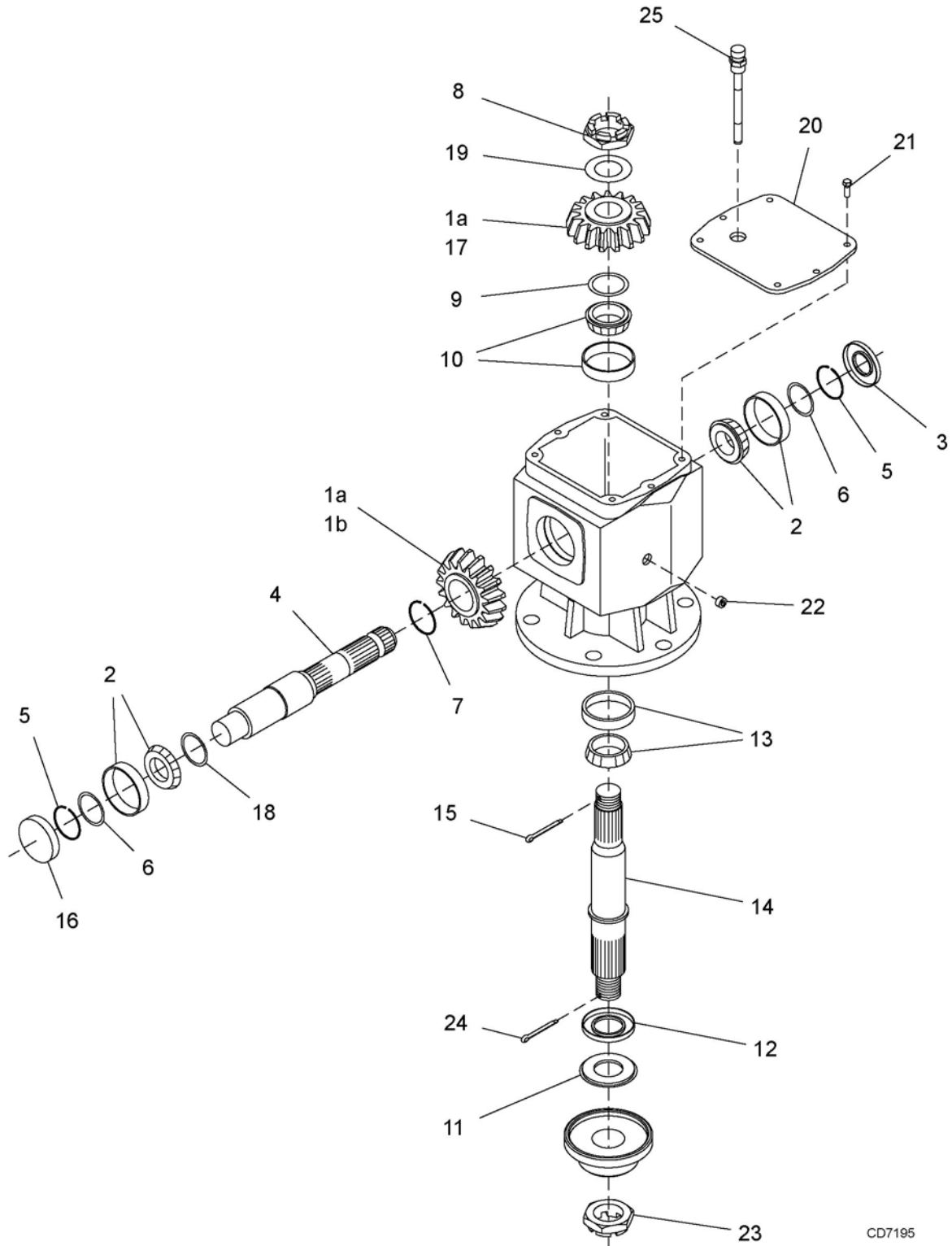


CD7194

## CENTER GEARBOX ASSEMBLY

REF	PART	QTY	DESCRIPTION	REF	PART	QTY	DESCRIPTION
A	1024794		Complete 540 RPM Gearbox assembly <b>(TS1680) -or-</b>	13	57452	1	Oil seal 60 x 110 x 10
A	1024796		Complete 1000 RPM Gearbox assembly <b>(TS1680Q)</b>	14	57451	1	Seal protector
1	1025600	1	Output shaft	15	1025603	1	Output shaft
2	57318	2	Oil seal 45 x 85 x 10	16	-----	*	Cotter pin B5 x 60
3	307201	26	M10 x 1.5P x 30mm HHCS	17	57329	2	Castle nut M40 x 1.5
4	1025601	2	Cover	18	1025604	1	Bearing, cup and cone
5	1008148	2	Bearing, cup and cone	19	1025605	1	Cover
6	57471	2	Shim 45.3 x 65.3 (57471 kit)	20	1025606	1	Input shaft
7a	1025615	2 or 1	Gear pinion 13T M9 <b>(TS1680) -or-</b>	21	1025607	1	Dust lip 55 x 90 x 10
7b	1025609	2	Gear crown 18T M8.6 <b>(TS1680Q)</b>	22	1025608	1	Bearing, cup and cone
8	57308	1	Castle nut M36 x 3	23	1025616	1	Gear crown 24T M9 <b>(TS1680)</b>
9	57471	2	Shim 70.3 x 84.7 (57471 kit)	24	1025610	1	Spacer
10	57471	2	Shim 50.3 x 70.3 (57471 kit)	25	6185	*	1/4 x 2-1/4 Cotter pin
11	39263	1	Bearing, cup and cone	26	1025618	1	Dipstick 1/2 x 6.73
12	57453	1	Bearing, cup and cone				
					HHCS		Hex Head Cap Screw
					*		Standard hardware, obtain locally

# SIDE GEARBOX ASSEMBLY



CD7195

**60 Parts**

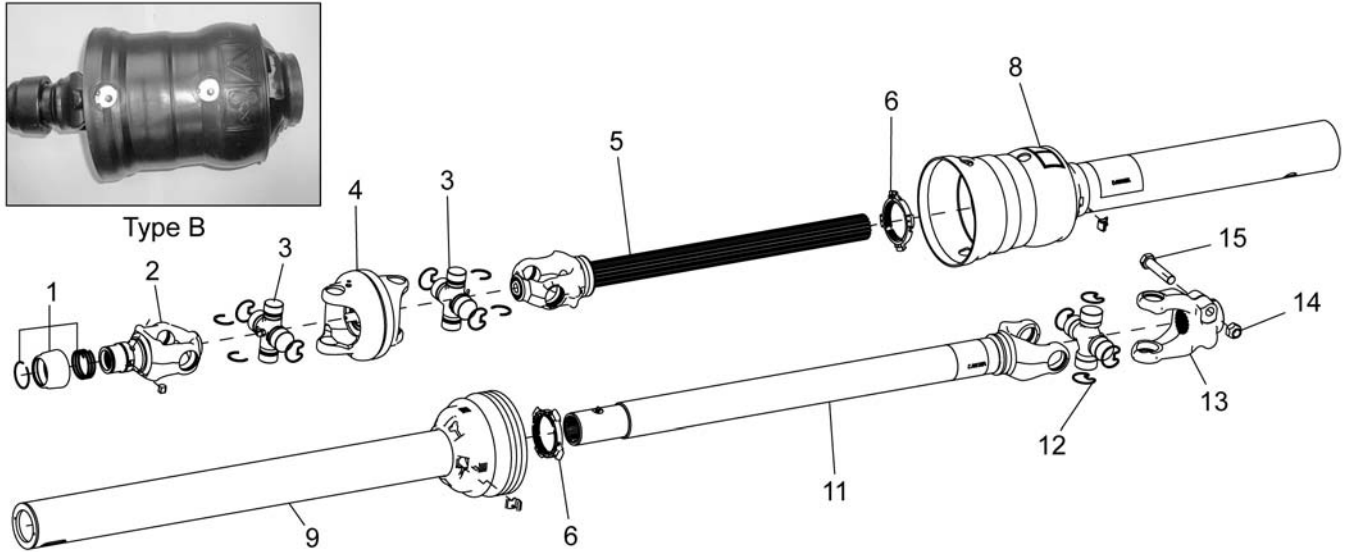
MAN0577 (6/29/2007)

## SIDE GEARBOX ASSEMBLY

REF	PART	QTY	DESCRIPTION	REF	PART	QTY	DESCRIPTION
A	1024795		Complete 540 RPM Gearbox assembly <b>(TS1680) -or-</b>	12	1025612	1	Dust lip 60 x 110 x 12
A	1024797		Complete 1000 RPM Gearbox assembly <b>(TS1680Q)</b>	13	57453	1	Bearing, cup & cone
1a	1025617	2	Gear crown 21T M7.8 <b>(TS1680)</b>	14	57454	1	Output shaft
1b	1025611	1	Gear crown 22T M7.8 <b>(TS1680Q)</b>	15	-----	*	B5 x 60 Cotter pin
2	39411	2	Bearing, cup & cone	16	57371	1	Oil cap 80 x 10
3	57318	1	Oil seal 45 x 85 x 10	17	1025614	1	Gear pinion 18T M7.9 (TS1680Q)
4	57450	1	Input shaft	18	57456	1	Shim 45.3 x 65.3 x 2.5)
5	57320	2	Snap ring, 85 x 88.5 x 3	19	57471	1	Shim 40.3 x 61.7 (57471 kit)
6	57471	2	Shim 70.3 x 84.7 (57471 kit)	20	1025613	1	Cover
7	57321	1	Snap ring, 50 x 47 x 2"	21	-----	*	M8 x 25 GR8.8 HHCS
8	57329	1	Castle nut M40 x 1.5	22	27326	*	3/8 NPT Solid plug
9	57471	1	Shim 50.3 x 70.3 (57471 kit)	23	57308	1	Castle nut M36 x 3
10	39263	1	Bearing, cup & cone	24	6185	*	1/4 x 2-1/4 Cotter pin
11	57451	1	Seal protector	25	57312	1	Dipstick 1/2 x 6.69
					HHCS		Hex Head Cap Screw
					*		Standard hardware, obtain locally



## TYPE B - 540 RPM FRONT CV DRIVE ASSEMBLY



Note 1: There are two types of Weasler drives  
See photo to determine type.

Note 2: Lube fitting at end of cross and bearing.

CD7143A-3

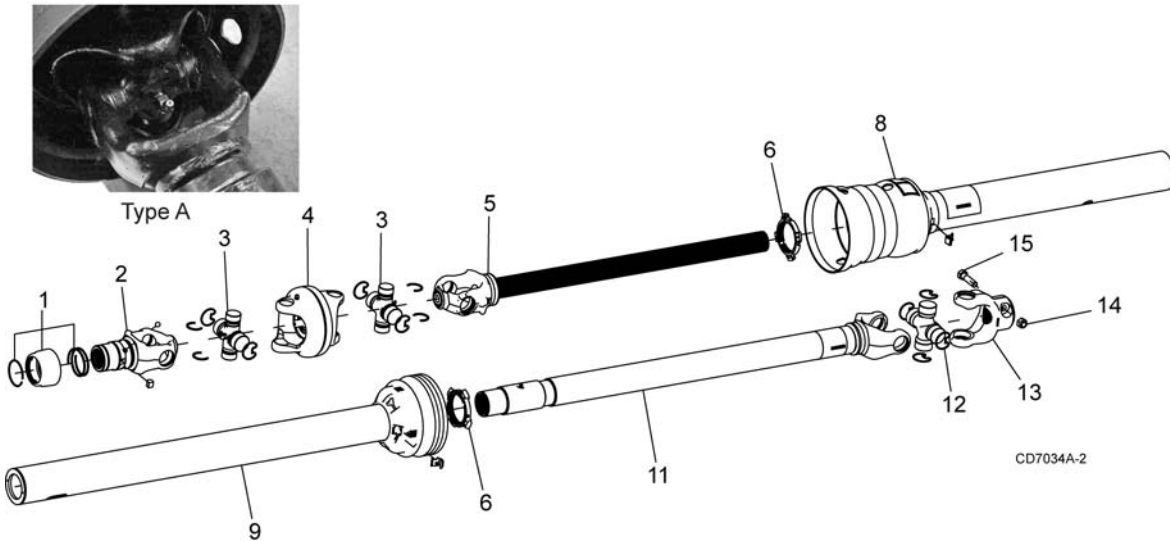
REF	PART	QTY	DESCRIPTION	REF	PART	QTY	DESCRIPTION
A	1024175	1	Weasler 540 rpm front CV drive complete	8	1019641	1	Outer shield, CV
1	19851	1	Slide lock repair kit, 1.38 ID	9	1021315	1	Inner shield, CV
2	1033103	1	Yoke, QD CV 1.375-6	10	33347	1	Danger decal - shield missing (N/S)
3	1033107	2	U-Joint repair kit, Cat 6 CV 55E	11	1021316	1	Yoke, tube & sleeve, 55R x 36.4 x 1.69-20
4	1033106	1	CV Body with fitting	12	58765	1	U-Joint cross & bearing kit 55E
5	1033114	1	Yoke & shaft - CV splined 30.4	13	1007869	1	Yoke, 55R x 4.50 x SP 1.5-23
6	1009065	2	Drive shield bearing kit	14	765 *	1	1/2 NC Lock nut
7	18864	1	Danger decal - rotating driveline (N/S)	15	3699 *	1	1/2 NC x 2 HHCS GR5

N/S Not Shown

HHCS Hex Head Cap Screw

\* Standard hardware, obtain locally

## TYPE A - 1000 RPM FRONT CV DRIVE ASSEMBLY



Note 1: There are two types of Weasler drives.  
See photo to determine type.

Note 2: Lube fitting in center of cross and bearing.

### 1000 RPM 1-3/8 21-Splined

### 1000 RPM 1-3/4 20-Splined

REF	PART	QTY	DESCRIPTION
A	1021102	1	Weasler 1000 RPM CV drive assembly complete, 21-spline
1	19851	1	Slide lock repair kit, 1.38 ID
2	58770	1	Yoke, QD CV 1.375-21
3	58759	2	U-Joint repair kit, 55E Cat 6 CV
4	58760	1	CV Body with fitting
5	1021305	1	Yoke & shaft, CV splined 32.3
6	1009065	2	Drive shield bearing kit
7	18864	1	Danger decal - Rotating driveline (N/S)
8	1021306	1	CV Outer shield
9	1021319	1	CV Inner shield
10	33347	1	Danger decal - Shield missing (N/S)
11	1021320	1	Yoke, tube & sleeve, 55R x 38.4 x 1.69-20
12	58765	1	U-Joint cross & bearing kit 55E
13	1007869	1	Yoke, 55R x 1.50 x SP 1.5-23
14	765 *	1	1/2 NC Lock nut
15	3699 *	1	1/2 NC x 2 HHCS GR5

N/S Not Shown

HHCS Hex Head Cap Screw

\* Standard hardware, obtain locally

REF	PART	QTY	DESCRIPTION
A	1021101	1	Weasler 1000 RPM CV drive assembly complete, 20-spline
1	19837	1	Slide lock repair kit, 1.75 ID
2	58758	1	Yoke, QD CV 1.75-20
3	58759	2	U-Joint repair kit, 55E Cat 6 CV
4	58760	1	CV Body with fitting
5	1021305	1	Yoke & shaft, CV splined 32.3
6	1009065	2	Drive shield bearing kit
7	18864	1	Danger decal - Rotating driveline (N/S)
8	1021306	1	CV Outer shield
9	1021307	1	CV Inner shield
10	33347	1	Danger decal - Shield missing (N/S)
11	1021308	1	Yoke, tube & sleeve, 55R x 42.5 x 1.69-20
12	58765	1	U-Joint cross & bearing kit 55E
13	1007869	1	Yoke, 55R x 1.50 x SP 1.5-23
14	765 *	1	1/2 NC Lock nut
15	3699 *	1	1/2 NC x 2 HHCS GR5

N/S Not Shown

HHCS Hex Head Cap Screw

\* Standard hardware, obtain locally

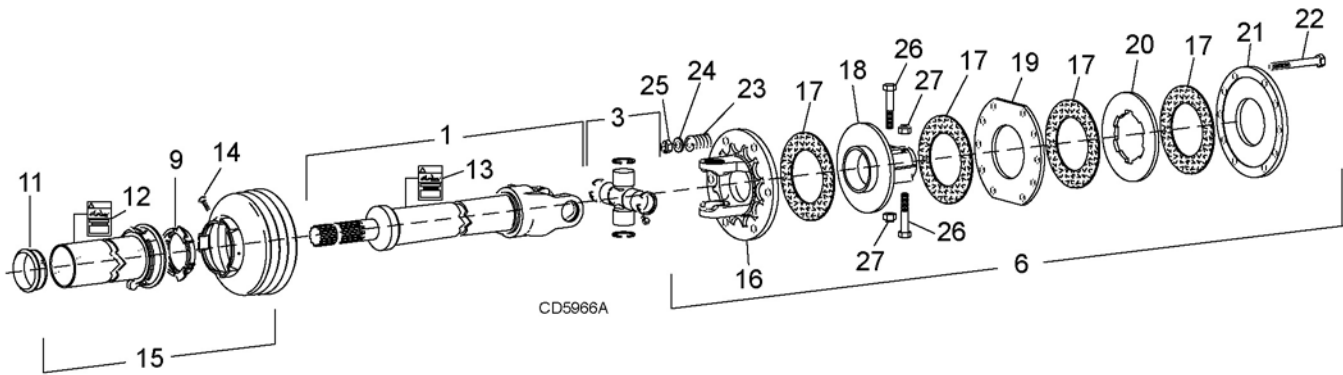
# 64 Parts

(Rev. 10/18/2010)  
MAN0577 (6/29/2007)





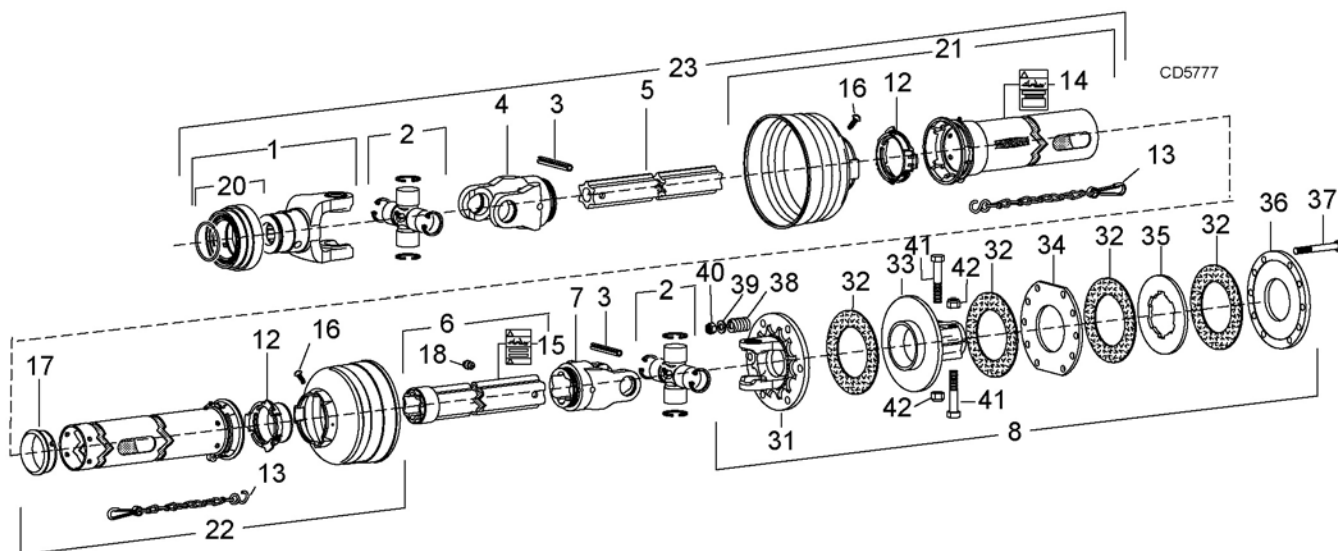
## REAR FIXED-LENGTH DRIVE FOR CONSTANT VELOCITY DRIVE



REF	PART	QTY	DESCRIPTION	REF	PART	QTY	DESCRIPTION
A	1022223	1	Drive assembly complete	17	57432	4	Friction disc
1	1024779	1	Drive without shield	18	57442	1	Hub, 1-3/4 - 20 I.C. - SN
3	40566	1	Cross & bearing kit	19	57443	1	Drive plate
6	57421	1	Friction clutch	20	57256	1	Drive plate - SN
9	40766	1	Bearing ring	21	57257	1	Thrust plate
11	40767	1	Support bearing	22	57263	6	M12 x 115 mm HHCS
12	18864	1	Danger decal - Rotating driveline	23	57258	6	Spring, compression
13	33347	1	Danger decal - Shield missing	24	57265	6	Flat washer, 24 x 13 x 2.5 mm
14	40778	1	Screw	25	57264	6	M12 Hex nut
15	1024780	1	Shield	26	57262	2	M12 x 65 mm HHCS
16	57441	1	Flange yoke	27	57261	2	M12 Hex nut

HHCS Hex Head Cap Screw

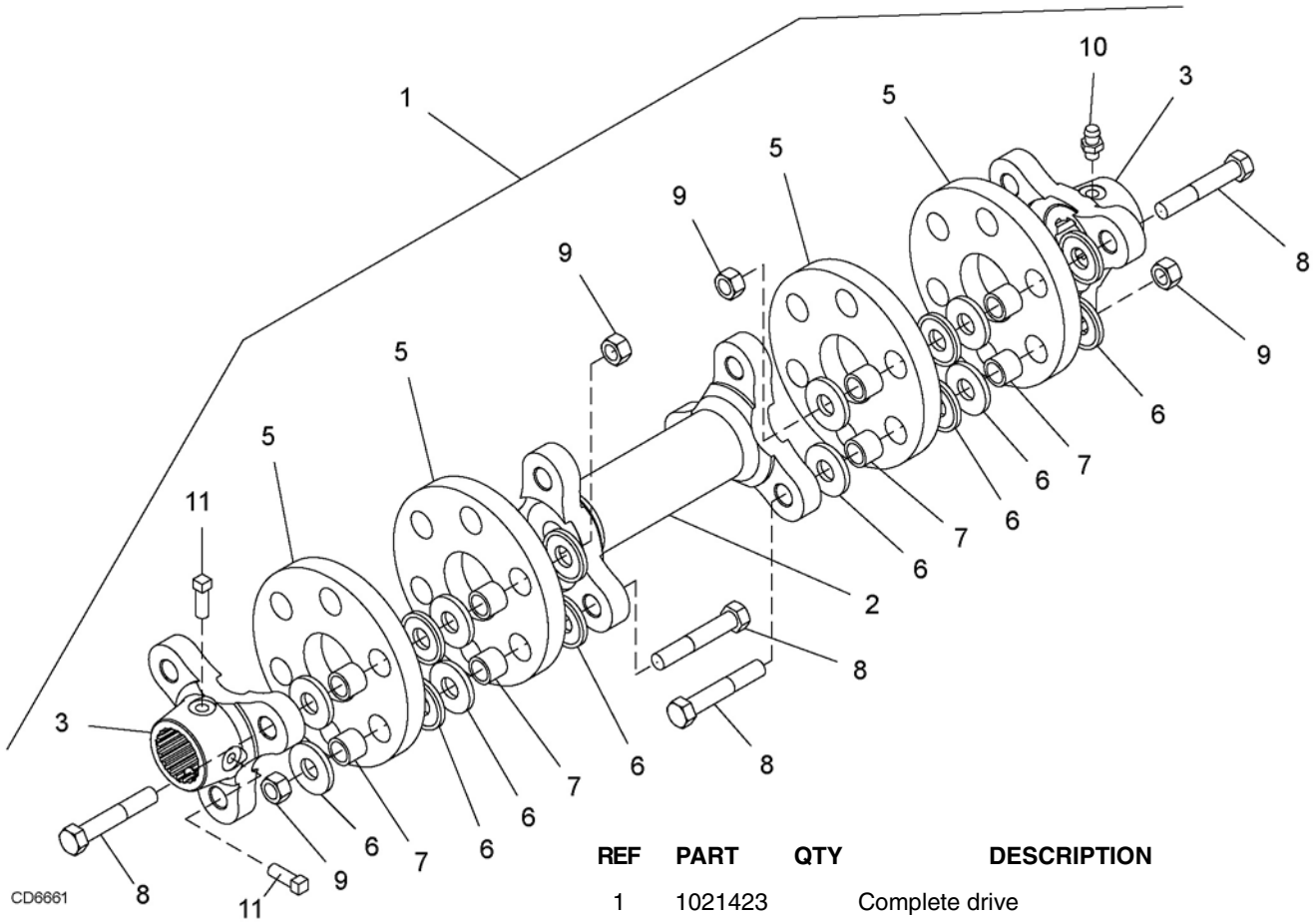
## SLIP CLUTCH DRIVE ASSEMBLY - MOUNTED



REF	PART	QTY	DESCRIPTION	REF	PART	QTY	DESCRIPTION
A	57419	1	Complete 540 RPM drive assembly - (TS1680) <b>-or-</b>	17	40767	1	Support bearing
A	57290	1	Complete 1000 RPM drive assembly - (TS1680Q) <b>-or-</b>	18	40779	1	Grease fitting
1	40563	1	Yoke, 1-3/8 - 6-Spline ASG - (TS1680) <b>-or-</b>	20	40758	1	Slide lock collar repair kit
1	40757	1	Yoke, 1-3/8 - 21-Spline AS - (TS1680Q) <b>-or-</b>	21	40727	1	Outer guard half
1	1001525	1	Yoke, 1-3/4 - 20-Spline AS	22	57273	1	Inner guard half
2	40566	2	Cross and bearing	23	40754	1	Male drive half, Complete (540 rpm) - (TS1680) <b>-or-</b>
3	40765	2	Spring pin 10 X 90	23	1003455	1	Male drive half, Complete (1000 rpm) - (TS1680Q) <b>-or-</b>
4	40750	1	Inboard yoke S4	31	57441	1	Flange yoke
5	40752	1	Inner profile S4	32	57432	4	Friction disc
6	44676	1	Outer profile & sleeve S5	33	57442	1	Hub 1-3/4 - 20 I.C. -SN
7	40751	1	Inboard yoke S5	34	57443	1	Drive plate
8	57421	1	Friction clutch, 1-3/4, 20-spline	35	57256	1	Drive plate - SN
12	40766	2	Bearing ring SC25	36	57257	1	Thrust plate
13	40777	2	Anti-rotation chain	37	57263	6	M12 x 115 mm HHCS
14	18864	1	Decal, Danger rotating driveline	38	57258	6	Spring, compression
15	33347	1	Decal, Danger guard missing	39	57265	6	Flat washer, 24 x 13 x 2.5 mm
16	40778	2	Screw	40	57264	6	M12 Hex lock nut
				41	57262	2	M12 x 65 mm HHCS
				42	57261	2	M12 Hex lock nut

HHCS Hex Head Cap Screw

# FLEXIBLE COUPLER

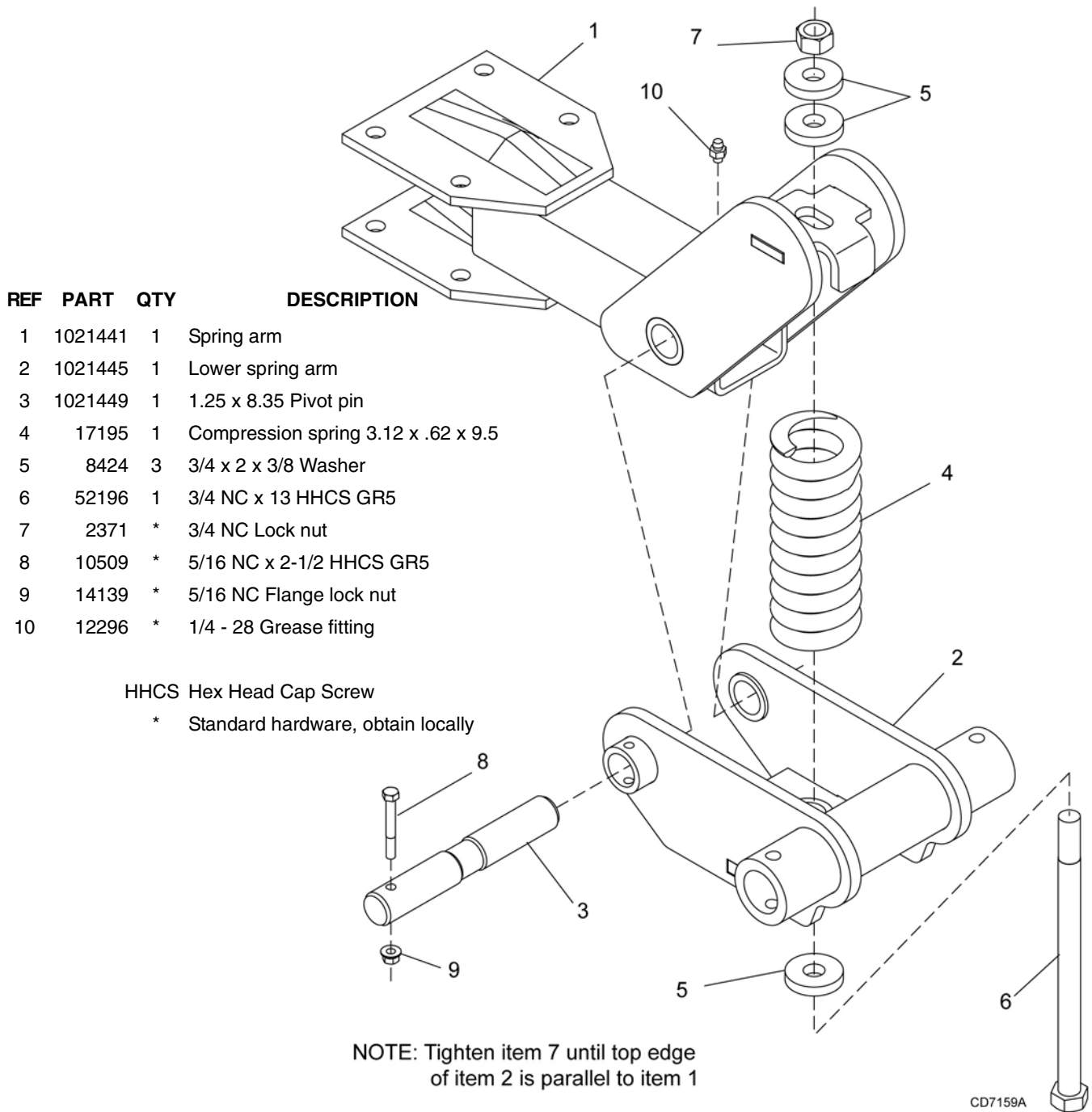


REF	PART	QTY	DESCRIPTION
1	1021423		Complete drive
2	-----	1	Inner connector yoke
3	1008147	2	Outer connector yoke 1-3/4 20-spline
5	1008140	4	Rubber disk
6	1008141	48	Shaped washer
7	1008142	24	Bushing, .63 I.D.
8	1001042	12	M16 x 2.0 x 90 mm HHCS
9	1008146	12	M16 x 2.0 Lock nut
10	----- *	1	Grease fitting
11	90016031 *	2	3/8 NC x 3/4 Square head set screw

HHCS Hex Head Cap Screw

\* Standard hardware, obtain locally

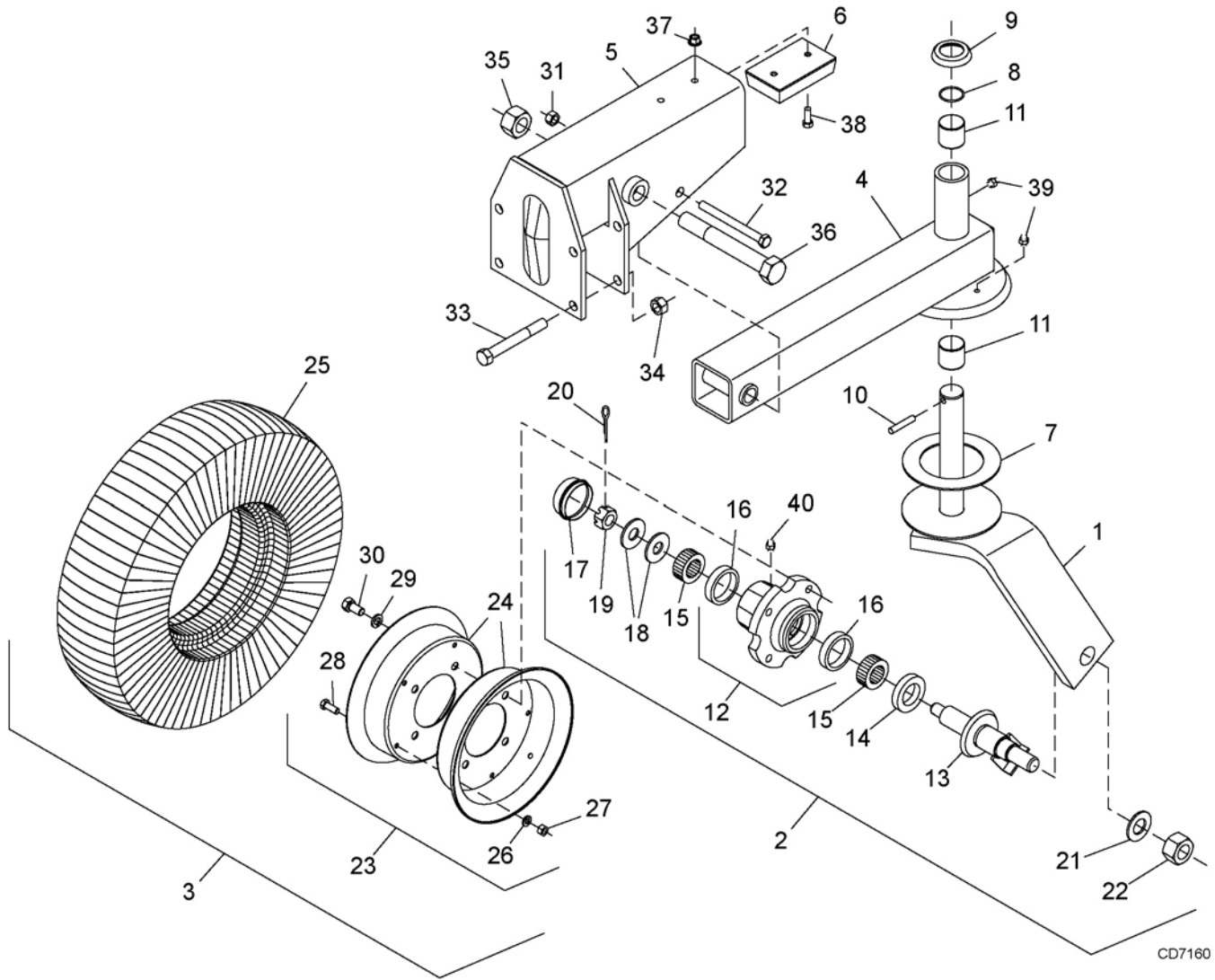
## SPRING WHEEL ARM ASSEMBLY - PULL TYPE



REF	PART	QTY	DESCRIPTION
1	1021441	1	Spring arm
2	1021445	1	Lower spring arm
3	1021449	1	1.25 x 8.35 Pivot pin
4	17195	1	Compression spring 3.12 x .62 x 9.5
5	8424	3	3/4 x 2 x 3/8 Washer
6	52196	1	3/4 NC x 13 HHCS GR5
7	2371	*	3/4 NC Lock nut
8	10509	*	5/16 NC x 2-1/2 HHCS GR5
9	14139	*	5/16 NC Flange lock nut
10	12296	*	1/4 - 28 Grease fitting

HHCS Hex Head Cap Screw  
 \* Standard hardware, obtain locally

# CASTER ARM ASSEMBLY - MOUNTED



CD7160

**70 Parts**

MAN0577 (6/29/2007)

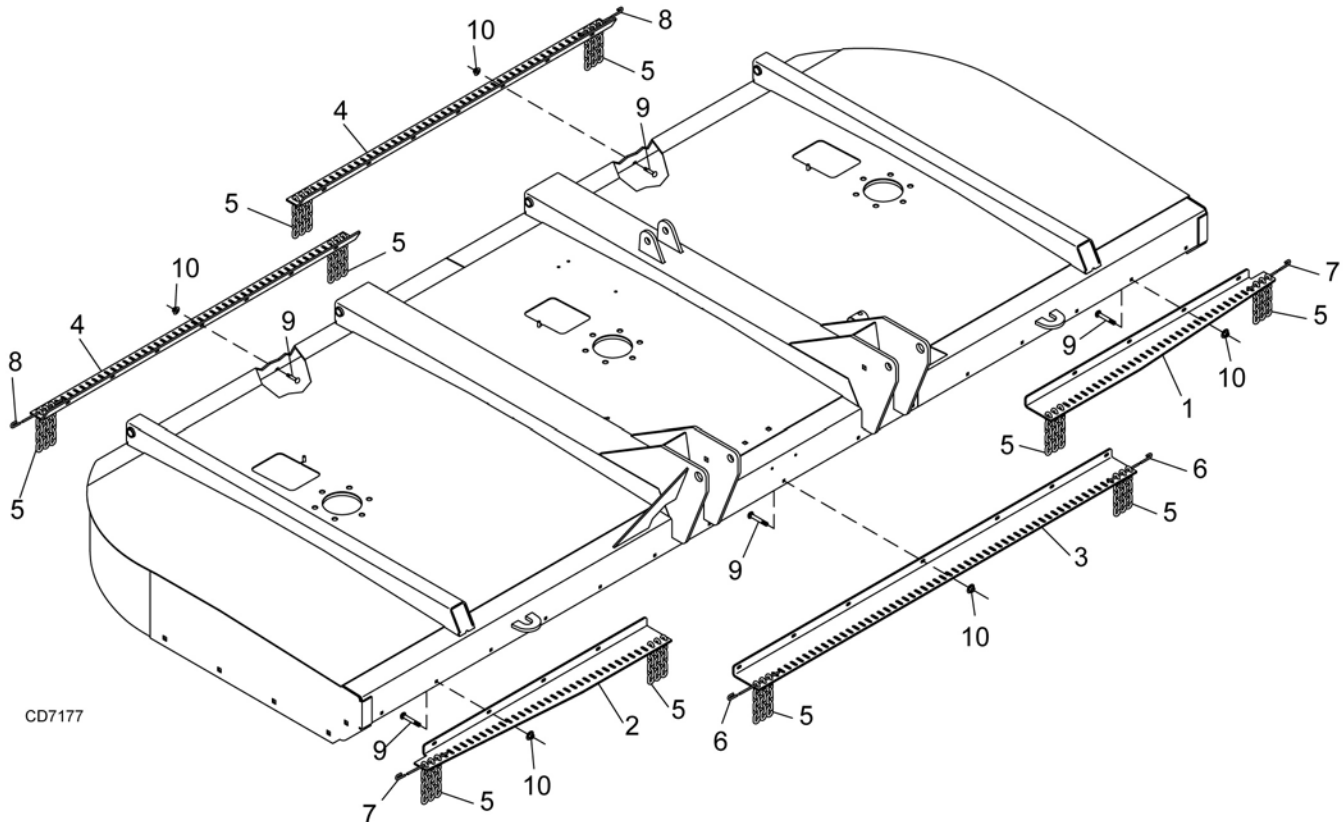
## CASTER ARM ASSEMBLY

REF	PART	QTY	DESCRIPTION	REF	PART	QTY	DESCRIPTION
1	39238	1	Caster yoke assembly	21	3689	*	1" Standard lock washer
2	4984	1	Heavy hub with long axle	22	3626	*	1-14 UNS Hex nut
3	7428	1	6.00 x 9 Solid tire & rim 21 OD	23	7431	1	Wheel, rim & hardware
4	39072	1	Center arm	24	7430	2	Rim half for 6.00 x 9 tire
5	39074	1	Damper arm	25	N/S	1	6.00 x 9 Tire
6	29070	1	Rubber pad	26	838	*	3/8 Standard lock washer
7	19459	1	Friction disc 4 x 6.15	27	835	*	3/8 NC Hex nut
8	12889	1	3/32 x 1-9/16 O-ring	28	19887	*	3/8 NC x 1 HHCS GR8
9	12881	1	Tailwheel cap washer	29	855	*	1/2 Heavy lock washer
10	4674	1	3/8 x 2 Spirol pin	30	4119	*	1/2 NF x 1 HHCS GR5
11	11011	2	1-1/2 x 1-5/8 x 1-1/2 Bronze bushing	31	765	*	1/2 NC Lock washer
12	530	1	Heavy wheel hub with cap	32	12305	*	1/2 NC x 5-1/2 HHCS GR5
13	6271	1	Long axle assembly for heavy hub	33	378	*	5/8 NC x 5 HHCS GR5
14	314	1	Seal for 1-1/2 shaft	34	6239	*	5/8 NC Hex lock nut
15	310	2	Bearing cone	35	34279		1" NC Hex lock nut
16	309	2	Bearing cup	36	15278		1" NC x 7-1/2 HHCS GR5
17	531	1	Hub cap	37	14350	*	3/8 NC Flange lock nut
18	1257	*	3/4 Standard flat washer	38	839	*	3/8 NC x 1 HHCS GR5
19	5849		3/4 NF Slotted Hex nut	39	12296	*	1/4 - 28 Grease fitting
20	1256	*	3/16 x 1 Cotter pin	40	1972	*	1/4 - 28 Tapered thread grease fitting

HHCS Hex Head Cap Screw

\* Standard hardware, obtain locally

## CHAIN SHIELDING (STANDARD)



REF	PART	QTY	DESCRIPTION
1	1021456	1	Left front chain shield plate
2	1021457	1	Right front chain shield plate
3	1021458	1	Center front chain shield plate
4	1021461	2	Rear chain shield plate
5	5498	237	5/16 Chain, 6 link
6	1007850	2	Pin 31 to 33 chains
7	1007853	2	Pin 37 to 39 chains
8	1007856	2	Pin 52 to 54 chains
9	20973	*	3/8 NC x 1-1/4 Carriage bolt GR5
10	14350	*	3/8 NC Flange nut

HHCS Hex Head Cap Screw

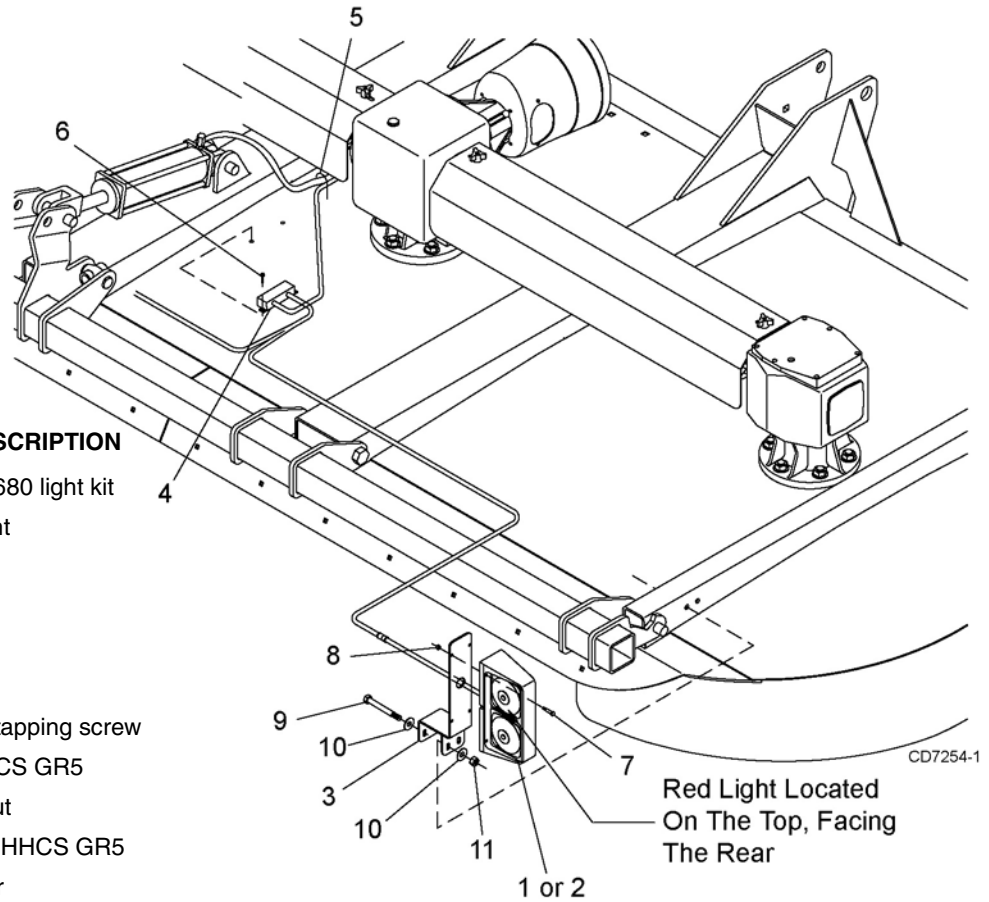
\* Standard hardware, obtain locally

**72 Parts**

(Rev 7/9/2010)  
MAN0577 (6/29/2007)



## LIGHT KIT (OPTIONAL)

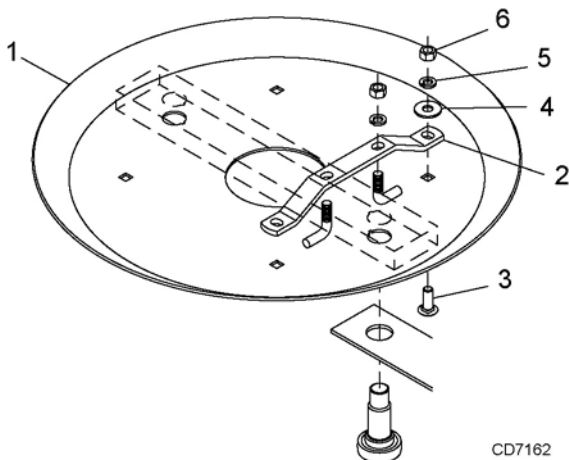


REF	PART	QTY	DESCRIPTION
A	1022245		Complete TS1680 light kit
1	90401149	1	Light, 4 pin right
2	90401150	1	Light, 4 pin left
3	1022246	2	Light bracket
4	1004479	1	Wire harness
5	31407	*	7" Tie strap
6	21374	*	#10 x 1/2 Self-tapping screw
7	10378	*	1/4 NC x 1 HHCS GR5
8	6128	*	1/4 NC Lock nut
9	12915	*	3/8 NC x 4-1/2 HHCS GR5
10	565	*	3/8 Flat washer
11	14350	*	3/8 NC Flange lock nut

HHCS Hex Head Cap Screw

\* Standard hardware, obtain locally

## STUMP JUMPER ASSEMBLY (OPTIONAL)

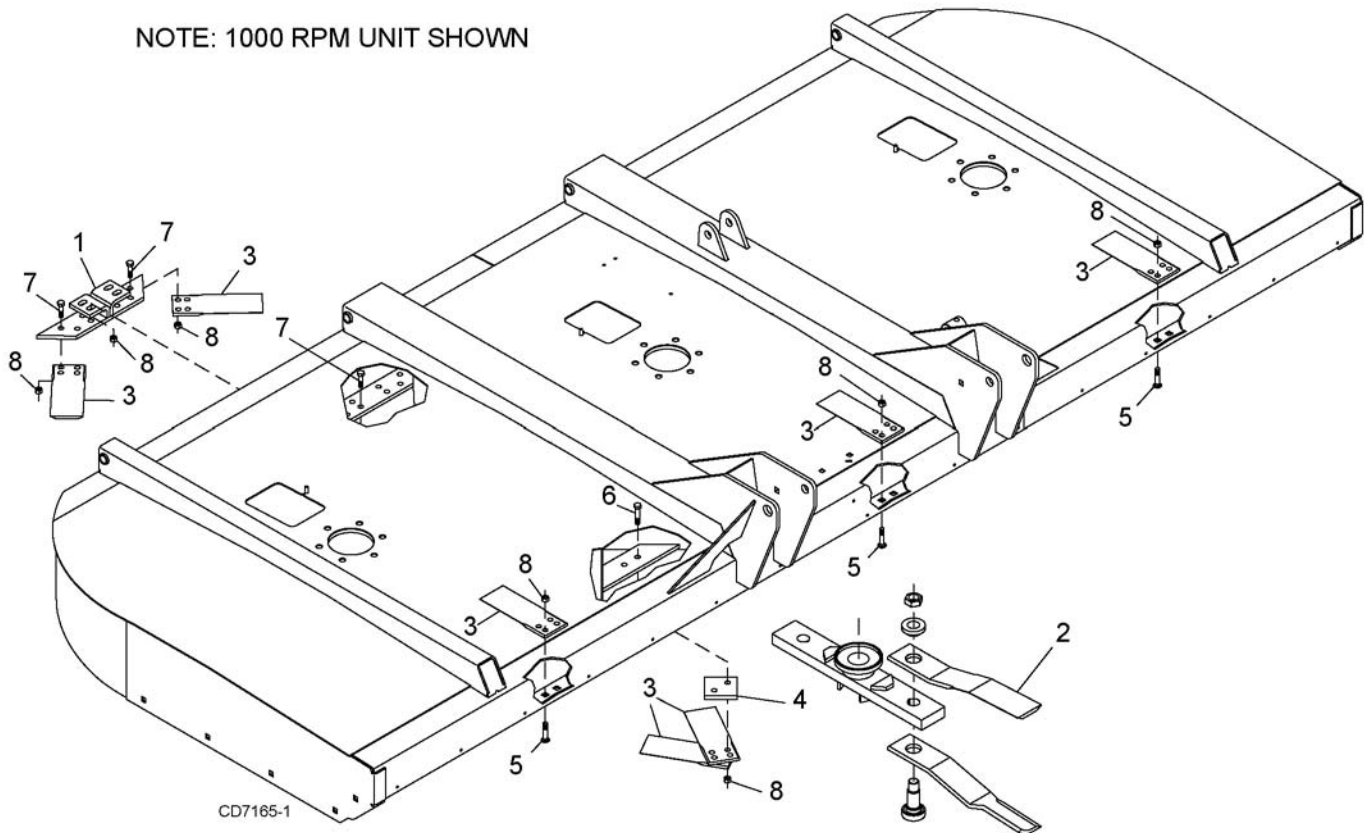


REF	PART	QTY	DESCRIPTION
1	1021435	1	Complete stump jumper assembly
2	1021436	2	Stump jumper strap
3	5607	*	5/8 NC x 1-1/2 Carriage bolt
4	692	*	5/8 Standard flat washer
5	1286	*	5/8 Heavy lock washer
6	230	*	5/8 NC Hex nut

\* Standard hardware, obtain locally

## SHREDDER KIT (OPTIONAL)

NOTE: 1000 RPM UNIT SHOWN



REF	PART	QTY	DESCRIPTION
A	1021463		Complete shredder kit
1	1021462	1	Blade holder
2	39004KT	6	Double edge blade, .5 x 4 x 22.5
3	39089	7	Double edge blade, 3/8 x 4 x 11.13
4	39048	1	Link, .5 x 4 x 4
5	5607 *	6	5/8 NC x 1-1/2 Carriage bolt GR5
6	34473 *		5/8 NC x 3 HHCS GR5
7	4548 *	8	5/8 NC x 1-3/4 HHCS GR5
8	6239 *		5/8 NC Lock nut

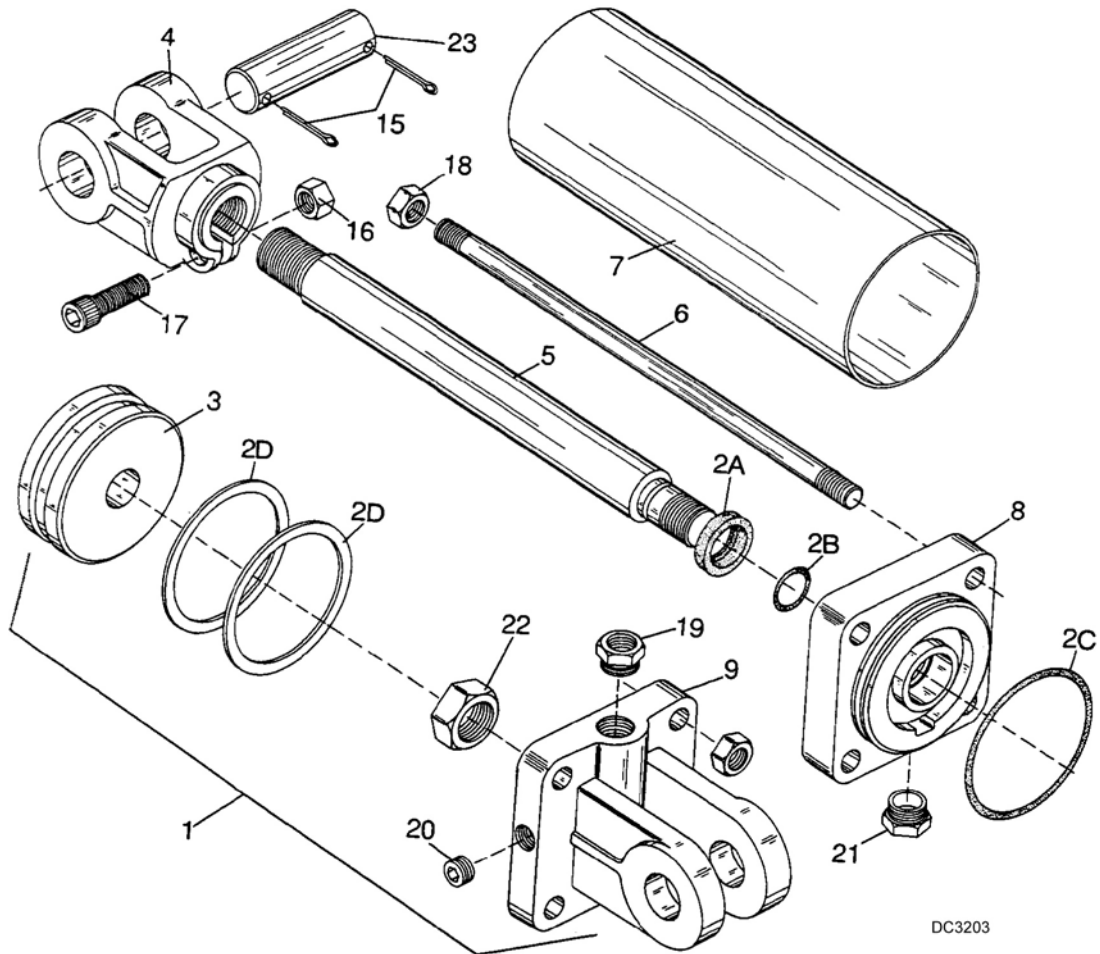
HHCS Hex Head Cap Screw

\* Standard hardware, obtain locally

**74 Parts**

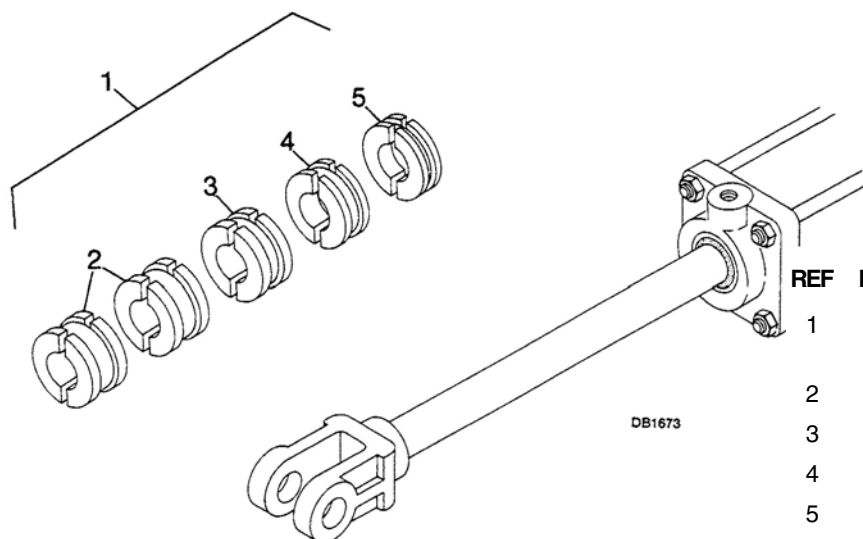
MAN0577 (6/29/2007)

### 3-1/2 x 8" STROKE HYDRAULIC CYLINDER (OPTIONAL)



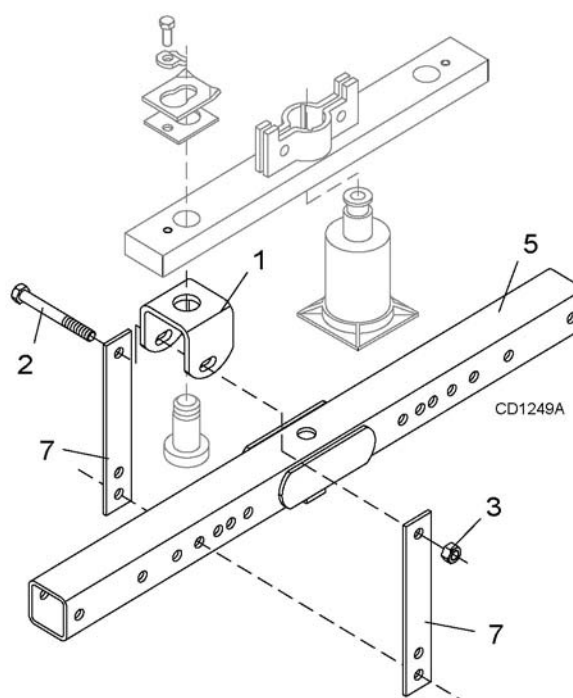
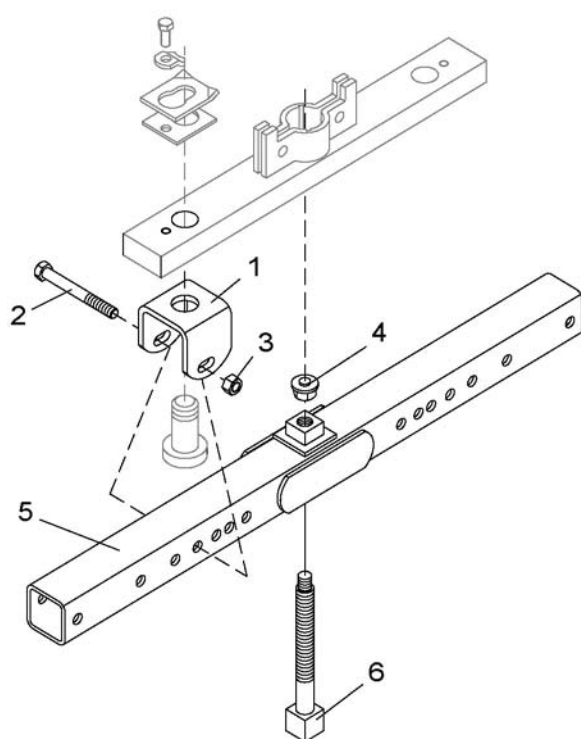
REF	PART	QTY	DESCRIPTION	REF	PART	QTY	DESCRIPTION
1	10475		Hydraulic cylinder complete, single acting (for pull-type & semi-mounted)	8	23543	1	Rod end housing, 1-1/4 bore
			<b>-or-</b>	9	23546	1	Cylinder butt end
1	18725		Hydraulic cylinder complete, double acting (for mounted unit only)	15	923 *		1/4 x 1-3/4 Cotter pin
2	23540		Seal repair kit (includes items 2A - 2D)	16	6698 *		3/8 NC Hex lock nut
2A	----- †		1-1/4 ID Wiper seal	17	23550		3/8 NC x 1-1/2 Socket head cap screw
2B	----- †		1-1/4 ID O-Ring	18	1093 *		1/2 NC Heavy hex nut
2C	----- †		3/16 x 3-1/2 OD O-Ring	19	11893		1/2 x 1/4 Pipe reducer bushing
2D	----- †		3-1/2 OD Back-up washer	20	----- *		1/2 Pipe plug
3	23544	1	Piston	21	11975		1/2 NPT Vent plug
4	23549	1	Cylinder rod clevis	22	25496		1-14 UNS Jam nut
5	23551	1	Cylinder rod	23	1631		1 x 3-5/8 Clevis pin
6	NSS	4	Tie rod				
7	NSS	1	Cylinder barrel				
				*			Standard hardware, obtain locally
				NSS			Not serviced separately
				†			Included in seal kit

## HYDRAULIC CYLINDER STROKE CONTROL KIT (OPTIONAL)



REF	PART	QTY	DESCRIPTION
1	24098	1	Stroke control set for 1-1/4" cylinder rod (contains items 2 - 5)
2	----	2	1-1/2" Segment
3	----	1	1-1/4" Segment
4	----	1	1" Segment
5	----	1	3/4" Segment

## CROSSBAR PULLER (OPTIONAL)



REF	PART	QTY	DESCRIPTION
A	8811	1	Crossbar puller, complete
1	19914	2	Crossbar puller clevis
2	3097 *	4	5/8 NC x 4-1/2 HHCS GR5
3	230 *	4	5/8 NC Hex nut
4	24879	1	Crossbar puller pad assembly

REF	PART	QTY	DESCRIPTION
5	24876	1	Crossbar puller tube assembly
6	24881	1	Crossbar puller screw assembly
7	24885	4	Crossbar puller link

HHCS Hex Head Cap Screw

\* Standard hardware, obtain locally

# 76 Parts

MAN0577 (6/29/2007)

# BOLT TORQUE CHART

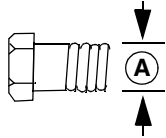
Always tighten hardware to these values unless a different torque value or tightening procedure is listed for a specific application.

Fasteners must always be replaced with the same grade as specified in the manual parts list.

Always use the proper tool for tightening hardware: SAE for SAE hardware and Metric for metric hardware.

Make sure fastener threads are clean and you start thread engagement properly.

All torque values are given to specifications used on hardware defined by SAE J1701 MAR 99 & J1701M JUL 96.



## SAE SERIES TORQUE CHART



SAE Grade 2  
(No Dashes)

SAE Bolt Head Identification

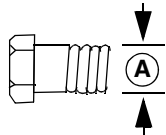


SAE Grade 5  
(3 Radial Dashes)



SAE Grade 8  
(6 Radial Dashes)

Ⓐ Diameter (Inches)	Wrench Size	MARKING ON HEAD					
		SAE 2		SAE 5		SAE 8	
		lbs-ft	N-m	lbs-ft	N-m	lbs-ft	N-m
1/4"	7/16"	6	8	10	13	14	18
5/16"	1/2"	12	17	19	26	27	37
3/8"	9/16"	23	31	35	47	49	67
7/16"	5/8"	36	48	55	75	78	106
1/2"	3/4"	55	75	85	115	120	163
9/16"	13/16"	78	106	121	164	171	232
5/8"	15/16"	110	149	170	230	240	325
3/4"	1-1/8"	192	261	297	403	420	569
7/8"	1-5/16"	306	416	474	642	669	907
1"	1-1/2"	467	634	722	979	1020	1383



## METRIC SERIES TORQUE CHART



8.8  
Metric  
Grade 8.8

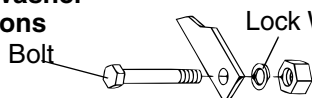
Metric Bolt Head Identification



10.9  
Metric  
Grade 10.9

Ⓐ Diameter & Thread Pitch (Millimeters)	Wrench Size	COARSE THREAD				FINE THREAD				Ⓐ Diameter & Thread Pitch (Millimeters)
		MARKING ON HEAD								
		Metric 8.8		Metric 10.9		Metric 8.8		Metric 10.9		
		N-m	lbs-ft	N-m	lbs-ft	N-m	lbs-ft	N-m	lbs-ft	
6 x 1.0	10 mm	8	6	11	8	8	6	11	8	6 x 1.0
8 x 1.25	13 mm	20	15	27	20	21	16	29	22	8 x 1.0
10 x 1.5	16 mm	39	29	54	40	41	30	57	42	10 x 1.25
12 x 1.75	18 mm	68	50	94	70	75	55	103	76	12 x 1.25
14 x 2.0	21 mm	109	80	151	111	118	87	163	120	14 x 1.5
16 x 2.0	24 mm	169	125	234	173	181	133	250	184	16 x 1.5
18 x 2.5	27 mm	234	172	323	239	263	194	363	268	18 x 1.5
20 x 2.5	30 mm	330	244	457	337	367	270	507	374	20 x 1.5
22 x 2.5	34 mm	451	332	623	460	495	365	684	505	22 x 1.5
24 x 3.0	36 mm	571	421	790	583	623	459	861	635	24 x 2.0
30 x 3.0	46 mm	1175	867	1626	1199	1258	928	1740	1283	30 x 2.0

### Typical Washer Installations



Lock Washer

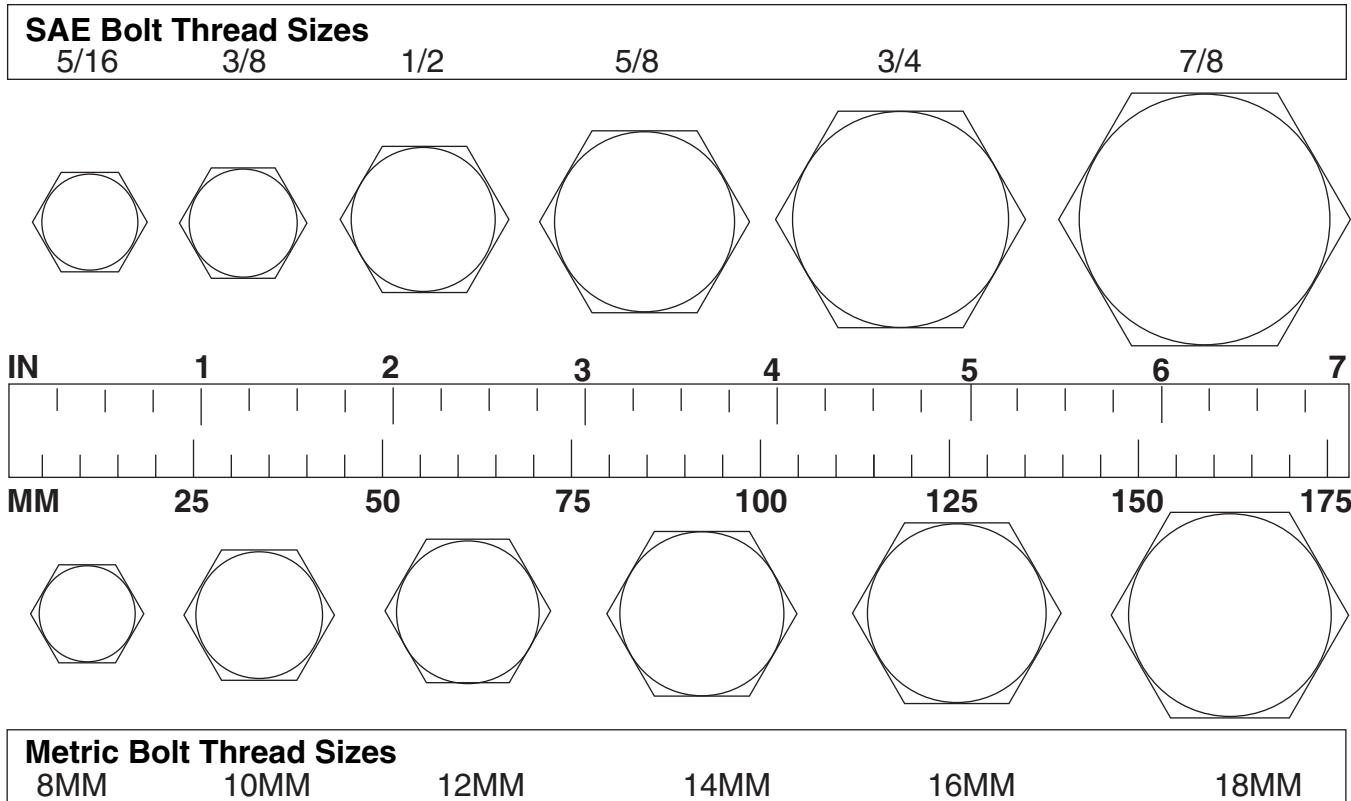
Flat Washer



8/9/00

# BOLT SIZE CHART

**NOTE:** Chart shows bolt thread sizes and corresponding head (wrench) sizes for standard SAE and metric bolts.



## ABBREVIATIONS

AG ..... Agriculture  
 ASABE ..... American Society of Agricultural & Biological Engineers (formerly ASAE)  
 ASAE..... American Society of Agricultural Engineers  
 ATF.....Automatic Transmission Fluid  
 BSPP..... British Standard Pipe Parallel  
 BSPTM..... British Standard Pipe Tapered Male  
 CV ..... Constant Velocity  
 CCW..... Counter-Clockwise  
 CW ..... Clockwise  
 F ..... Female  
 FT..... Full Thread  
 GA ..... Gauge  
 GR (5, etc.)..... Grade (5, etc.)  
 HHCS ..... Hex Head Cap Screw  
 HT ..... Heat-Treated  
 JIC..... Joint Industry Council 37° Degree Flare  
 LH..... Left Hand  
 LT ..... Left  
 m ..... Meter  
 mm ..... Millimeter  
 M ..... Male

MPa ..... Mega Pascal  
 N ..... Newton  
 NC..... National Coarse  
 NF ..... National Fine  
 NPSM ..... National Pipe Straight Mechanical  
 NPT.....National Pipe Tapered  
 NPT SWF..... National Pipe Tapered Swivel Female  
 ORBM ..... O-Ring Boss - Male  
 P ..... Pitch  
 PBY.....Power-Beyond  
 psi ..... Pounds per Square Inch  
 PTO.....Power Take Off  
 QD ..... Quick Disconnect  
 RH..... Right Hand  
 ROPS..... Roll-Over Protective Structure  
 RPM.....Revolutions Per Minute  
 RT ..... Right  
 SAE..... Society of Automotive Engineers  
 UNC ..... Unified Coarse  
 UNF ..... Unified Fine  
 UNS ..... Unified Special

# INDEX

## A

### ASSEMBLY

- Dealer Set-Up Instructions 38
- TS1680 Mounted Cutter 42
- TS1680 Pull-Type Cutter - Front Half 40
- TS1680 Pull-Type Cutter - Rear Half 38

## D

### DEALER CHECK LISTS

- Delivery (Dealer's Responsibility) 48
- Pre-Delivery (Dealer's Responsibility) 48

### DEALER SERVICE

- Center Gearbox Repair
  - Assembly 33
  - Disassembly 33
  - Installation 34
  - Removal 32
- Crossbar
  - Installation 35
  - Removal 34
  - Timing 36
- Gearbox Maintenance 29
  - Horizontal Shaft Seal Repair (Side Gearbox) 30
  - Seal Installation 29
  - Seal Replacement 29
  - Vertical Shaft Seal Repair (Side Gearbox) 29
- Side Drive Service 34
- Side Gearbox Repair
  - Assembly 30
  - Disassembly 30
  - Installation 31
  - Removal 30
- Universal Joint
  - Assembly 37
  - Disassembly 36
  - Repair 36

## G

### GENERAL

- Abbreviations 78
- Bolt Size Chart 78
- Bolt Torque Chart 77
- General Information 4
- Introduction 2
- Obtaining Replacement Manuals 2
- Product Registration 2
- Specifications 4
- Table of Contents 3
- Warranty
  - Product 74
  - Replacement Parts 75

## O

### OPERATION

- Attitude Adjustment (Pull-Type)
  - Normal Mowing 18
  - Shredding 18
- Blade Selection 18
- Connect Cutter to Tractor
  - Mounted
    - Category 2 & 3 Quick Hitches 16

- Category 2 Standard Hitch 15
- Category 3 Standard Hitch 15
- Tractor Adjustments 15
- Pull-Type 14
  - Hydraulic Connection 15
  - Interference Check 15
  - Turning Limits for Optional CV Driveline 15

### Cutting Height Adjustment

- Mounted Units 17
- Pull-Type Units 17

### Driveline Adjustment (Mounted) 16

- Driveline Interference Check 17
- Shorten Driveline 16

### Driveline Adjustment (Pull-Type) 18

### Operating Technique 18

- Cutter Operation 19
- Mowing Tips 19

### Pre-Operation Check List (Owner's Responsibility) 20

### Storage 19

### Tractor Operation 18

### Tractor Stability 14

### Transporting 19

### Wheel Spacing 18

## OWNER SERVICE

### Blade Servicing

- Installation 23
- Removal 23
- Sharpening 23

### Blocking Method 21

### Cleaning 26

### Flexible Coupler Rubber Disk Replacement 25

### Jackstand Placement Diagram 22

### Lubrication 21

#### Driveline 21

#### Gearbox 21

#### Lubrication Points Diagram 22

### Service Tires Safely 25

### Shielding Repair

#### Optional Chain Shielding 24

### Slip Clutch Adjustment 24

## P

## PARTS

### Index to Parts Lists 49

## S

## SAFETY

### Blocking Method 21

### Check Lists

#### Delivery (Dealer's Responsibility) 48

#### Pre-Delivery (Dealer's Responsibility) 48

#### Pre-Operation (Owner's Responsibility) 20

### Free Mower Safety Video Order Form 5, 6

### Safety & Instructional Decals 11, 12, 13

### Safety Rules 7, 8, 9, 10

### Safety Symbols Explained 2

## T

## TROUBLESHOOTING

### Problems & Solutions 27



## WARRANTY

(Replacement Parts For All Models Except Mow'n Machine™  
Zero-Turn Mowers and Woods Boundary™ Utility Vehicles)

Woods Equipment Company ("WOODS") warrants this product to be free from defect in material and workmanship for a period of ninety (90) days from the date of delivery of the product to the original purchaser with the exception of V-belts, which will be free of defect in material and workmanship for a period of 12 months.

Under no circumstances will this Warranty apply in the event that the product, in the good faith opinion of WOODS, has been subjected to improper operation, improper maintenance, misuse, or an accident. This Warranty does not cover normal wear or tear, or normal maintenance items.

This Warranty is extended solely to the original purchaser of the product. Should the original purchaser sell or otherwise transfer this product to a third party, this Warranty does not transfer to the third party purchaser in any way. There are no third party beneficiaries of this Warranty.

WOODS' obligation under this Warranty is limited to, at WOODS' option, the repair or replacement, free of charge, of the product if WOODS, in its sole discretion, deems it to be defective or in noncompliance with this Warranty. **The product must be returned to WOODS with proof of purchase within thirty (30) days after such defect or noncompliance is discovered or should have been discovered, routed through the dealer and distributor from whom the purchase was made, transportation charges prepaid.** WOODS shall complete such repair or replacement within a reasonable time after WOODS receives the product. THERE ARE NO OTHER REMEDIES UNDER THIS WARRANTY. THE REMEDY OF REPAIR OR REPLACEMENT IS THE SOLE AND EXCLUSIVE REMEDY UNDER THIS WARRANTY.

THERE ARE NO WARRANTIES WHICH EXTEND BEYOND THE DESCRIPTION ON THE FACE OF THIS WARRANTY. WOODS MAKES NO OTHER WARRANTY, EXPRESS OR IMPLIED, AND WOODS SPECIFICALLY DISCLAIMS ANY IMPLIED WARRANTY OF MERCHANTABILITY AND/OR ANY IMPLIED WARRANTY OF FITNESS FOR A PARTICULAR PURPOSE.

**WOODS shall not be liable for any incidental or consequential losses, damages or expenses, arising directly or indirectly from the product, whether such claim is based upon breach of contract, breach of warranty, negligence, strict liability in tort or any other legal theory.** Without limiting the generality of the foregoing, Woods specifically disclaims any damages relating to (i) lost profits, business, revenues or goodwill; (ii) loss of crops; (iii) loss because of delay in harvesting; (iv) any expense or loss incurred for labor, supplies, substitute machinery or rental; or (v) any other type of damage to property or economic loss.

This Warranty is subject to any existing conditions of supply which may directly affect WOODS' ability to obtain materials or manufacture replacement parts.

No agent, representative, dealer, distributor, service person, salesperson, or employee of any company, including without limitation, WOODS, its authorized dealers, distributors, and service centers, is authorized to alter, modify, or enlarge this Warranty.

Answers to any questions regarding warranty service and locations may be obtained by contacting:

**ALITEC™**  
**BMP®**  
**CENTRAL FABRICATORS®**  
**GANNON®**  
**GILL®**  
**WAIN-ROY®**  
**WOODS®**

**WOODS®**

**Woods Equipment  
Company**

2606 South Illinois Route 2  
Post Office Box 1000  
Oregon IL 61061

800-319-6637 tel  
800-399-6637 fax  
[www.WoodsEquipment.com](http://www.WoodsEquipment.com)





# WARRANTY

All Models Except Mow'n Machine™ Zero-Turn Mowers

Please Enter Information Below and Save for Future Reference.

Date Purchased: \_\_\_\_\_ From (Dealer): \_\_\_\_\_

Model Number: \_\_\_\_\_ Serial Number: \_\_\_\_\_

Woods Equipment Company ("WOODS") warrants this product to be free from defect in material and workmanship. Except as otherwise set forth below, the duration of this Warranty shall be for TWELVE (12) MONTHS COMMENCING ON THE DATE OF DELIVERY OF THE PRODUCT TO THE ORIGINAL PURCHASER.

All current model loaders and backhoes are warranted for two (2) years from the date of delivery to the original purchaser.

The warranty periods for specific parts or conditions are listed below:

Part or Condition Warranted	Model Number	Duration (from date of delivery to the original purchaser)
Gearbox Seals	All units listed below	2 years
Gearbox components	BW1260, BW1620, BW1800, BW2400	8 years
	BW240HD, BW180HD, BW180HB, BW126HB	7 years
	BB48X, BB60X, BB72X, BB84X, BB600X, BB720X, BB840X, BB6000X, BB7200X, BB8400X, DS1260, DSO1260, DS1440, TS1680, BW126-3, BW180-3, BW240	6 years
	PHD25, PHD35, PHD65, PHD95, 2162, 3240, DS96, DS120, RCC42, RM550-2, RM660-2, RM990-3, PRD6000, PRD7200, PRD8400, S15CD, S20CD, S22CD, S25CD, S27CD, BW180LH, TC/R74, TC/R68, TC/R60, TBW144, TBW180, TBW204	5 years
	RDC54, RD60, RD72, TBW150C, TS/R60, TS/R52, TS/R44	3 years (1 year if used in rental or commercial applications)
Blade spindles	RM550-2, RM660-2, RM990-3, PRD6000, PRD7200, PRD8400, 7144RD-2, 9180RD-2, 9204RD-2	3 years
Rust-through	BB600, BB720, BB840, BB6000, BB7200, BB8400, BW126-3, BW126HB, BW180-3, BW180HB, BW180HD, BW1260, BW1800, BW240, BW240HD, 2162, 3240, DS1260, DSO1260, DS1440, TS1680	10 years

Under no circumstances will this Warranty apply in the event that the product, in the good faith opinion of WOODS, has been subjected to improper operation, improper maintenance, misuse, or an accident. This Warranty does not apply in the event that the product has been materially modified or repaired by someone other than WOODS, a WOODS authorized dealer or distributor, and/or a WOODS authorized service center. This Warranty does not cover normal wear or tear, or normal maintenance items. This Warranty also does not cover repairs made with parts other than those obtainable through WOODS.

This Warranty is extended solely to the original purchaser of the product. Should the original purchaser sell or otherwise transfer this product to a third party, this Warranty does not transfer to the third party purchaser in any way. There are no third party beneficiaries of this Warranty.

WOODS makes no warranty, express or implied, with respect to engines, batteries, tires or other parts or accessories not manufactured by WOODS. Warranties for these items, if any, are provided separately by their respective manufacturers.

WOODS' obligation under this Warranty is limited to, at WOODS' option, the repair or replacement, free of charge, of the product if WOODS, in its sole discretion, deems it to be defective or in noncompliance with this Warranty. **The product must be returned to WOODS with proof of purchase within thirty (30) days after such defect or noncompliance is discovered or should have been discovered, routed through the dealer and distributor from whom the purchase was made, transportation charges prepaid.** WOODS shall complete such repair or replacement within a reasonable time after WOODS receives the product. **THERE ARE NO OTHER REMEDIES UNDER THIS WARRANTY. THE REMEDY OF REPAIR OR REPLACEMENT IS THE SOLE AND EXCLUSIVE REMEDY UNDER THIS WARRANTY.**

THERE ARE NO WARRANTIES WHICH EXTEND BEYOND THE DESCRIPTION ON THE FACE OF THIS WARRANTY. WOODS MAKES NO OTHER WARRANTY, EXPRESS OR IMPLIED, AND WOODS SPECIFICALLY DISCLAIMS ANY IMPLIED WARRANTY OF MERCHANTABILITY AND/OR ANY IMPLIED WARRANTY OF FITNESS FOR A PARTICULAR PURPOSE.

**WOODS shall not be liable for any incidental or consequential losses, damages or expenses, arising directly or indirectly from the product, whether such claim is based upon breach of contract, breach of warranty, negligence, strict liability in tort or any other legal theory.** Without limiting the generality of the foregoing, Woods specifically disclaims any damages relating to (i) lost profits, business, revenues or goodwill; (ii) loss of crops; (iii) loss because of delay in harvesting; (iv) any expense or loss incurred for labor, supplies, substitute machinery or rental; or (v) any other type of damage to property or economic loss.

This Warranty is subject to any existing conditions of supply which may directly affect WOODS' ability to obtain materials or manufacture replacement parts.

No agent, representative, dealer, distributor, serviceperson, salesperson, or employee of any company, including without limitation, WOODS, its authorized dealers, distributors, and service centers, is authorized to alter, modify, or enlarge this Warranty. Answers to any questions regarding warranty service and locations may be obtained by contacting:

### Woods Equipment Company

2606 South Illinois Route 2  
Post Office Box 1000  
Oregon, Illinois 61061 USA

800-319-6637 tel  
800-399-6637 fax  
www.WoodsEquipment.com



**ALITEC™**

**BMP®**

**CENTRAL FABRICATORS®**

**GANNON®**

**GILL®**

**WAIN-ROY®**

**WOODS®**

**PART NO.**  
**MAN0577**

**Woods Equipment  
Company**

2606 South Illinois Route 2  
Post Office Box 1000  
Oregon, Illinois 61061

800-319-6637 tel  
800-399-6637 fax  
[www.WoodsEquipment.com](http://www.WoodsEquipment.com)

**WOODS®**

© 2007 Woods Equipment Company. All rights reserved. WOODS, the Woods logo, and "Tested. Proven. Unbeatable." are trademarks of Woods Equipment Company. All other trademarks, trade names, or service marks not owned by Woods Equipment Company that appear in this manual are the property of their respective companies or mark holders. Specifications subject to change without notice.

## Free Manuals Download Website

<http://myh66.com>

<http://usermanuals.us>

<http://www.somanuals.com>

<http://www.4manuals.cc>

<http://www.manual-lib.com>

<http://www.404manual.com>

<http://www.luxmanual.com>

<http://aubethermostatmanual.com>

Golf course search by state

<http://golfingnear.com>

Email search by domain

<http://emailbydomain.com>

Auto manuals search

<http://auto.somanuals.com>

TV manuals search

<http://tv.somanuals.com>