

WOODS

211822 LOADER MOUNTING KIT

For 1020, 1027 Loaders

On Massey Ferguson® Tractors

5425, 5435, 5445

Or Challenger® Tractors

MT425B, MT445B

Includes Hose Kit

57988

MAN0469

(9/9/2005)

**SAVE THIS
MANUAL!**

Include it with
your Loader Manual.
It contains safety,
operation, and repair
part information
not found in other
manuals.

WOODS®

Tested. Proven. Unbeatable.

INSTALLATION MANUAL

TO THE DEALER:

Assembly and proper installation of this product is the responsibility of the Woods® dealer. Read manual instructions and safety rules. Make sure all items on the Dealer's Pre-Delivery and Delivery Check Lists in the Loader Operator's Manual are completed before releasing equipment to the owner.

TO THE OWNER:

Read this manual and Loader Operator's Manual before operating your Woods equipment. The information presented will prepare you to do a better and safer job. Keep this manual handy for ready reference. Require all operators to read this manual carefully and become acquainted with all adjustment and operating procedures before attempting to operate. Replacement manuals can be obtained from your dealer. To locate your nearest dealer, check the Dealer Locator at www.WoodsEquipment.com, or in the United States and Canada call 1-800-319-6637.

The equipment you have purchased has been carefully engineered and manufactured to provide dependable and satisfactory use. Like all mechanical products, it will require cleaning and upkeep. Lubricate the unit as specified. Observe all safety information in this manual and safety decals on the equipment.

For service, your authorized Woods dealer has trained mechanics, genuine Woods service parts, and the necessary tools and equipment to handle all your needs.

Use only genuine Woods service parts. Substitute parts will void the warranty and may not meet standards required for safe and satisfactory operation. Record the model number of your equipment in the space provided.

Model: _____ **Date of Purchase:** _____

Provide this information to your dealer to obtain correct repair parts.

Throughout this manual, the term **IMPORTANT** is used to indicate that failure to observe can cause damage to equipment. The terms **CAUTION**, **WARNING**, and **DANGER** are used in conjunction with the Safety-Alert Symbol (a triangle with an exclamation mark) to indicate the degree of hazard for items of personal safety.



This Safety-Alert Symbol indicates a hazard and means **ATTENTION! BECOME ALERT! YOUR SAFETY IS INVOLVED!**



Indicates an imminently hazardous situation that, if not avoided, will result in death or serious injury.



Indicates a potentially hazardous situation that, if not avoided, could result in death or serious injury, and includes hazards that are exposed when guards are removed.



Indicates a potentially hazardous situation that, if not avoided, may result in minor or moderate injury.

IMPORTANT

Indicates that failure to observe can cause damage to equipment.

NOTE

Indicates helpful information.

WOODS®

ALITEC™
BMP®
CENTRAL FABRICATORS®
GANNON®
GILL®
WAIN-ROY®
WOODS®

2 Introduction

LMK (Rev. 6/6/2005)



SAFETY RULES

ATTENTION! BECOME ALERT! YOUR SAFETY IS INVOLVED!



¡LEA EL INSTRUCTIVO!

Si no lee Ingles, pida ayuda a alguien que si lo lea para que le traduzca las medidas de seguridad.

Safety is a primary concern in the design and manufacture of our products. Unfortunately, our efforts to provide safe equipment can be wiped out by an operator's single careless act.

In addition to the design and configuration of equipment, hazard control and accident prevention are dependent upon the awareness, concern, judgement, and proper training of personnel involved in the operation, transport, maintenance, and storage of equipment.

It has been said, "The best safety device is an informed, careful operator." We ask you to be that kind of operator.

INSTALLATION

- This Loader Mounting Kit is to be used only for the loaders and tractors specified in this manual. Any other use or modification of this mounting kit may result in serious injury or death.
- Hydraulics must be connected as instructed in this manual. Do not substitute parts, modify, or connect in any other way.
- After connecting hoses, check that all control lever positions function as instructed in the Operator's Manual. Do not put into service until control lever and equipment movements are correct.
- Safety instructions are important! Read all attachment and power unit manuals; follow all safety rules and safety decal information. (Replacement manuals and safety decals are available from your dealer. To locate your nearest dealer, check the Dealer Locator at www.WoodsEquipment.com, or in the United States and Canada call 1-800-319-6637.) Failure to follow instructions or safety rules can result in serious injury or death.
- Keep hands and body away from pressurized lines. Use paper or cardboard, not hands or other body parts to check for leaks. Wear safety goggles. Hydraulic fluid under pressure can easily penetrate skin and will cause serious injury or death.
- Make sure that all operating and service personnel know that if hydraulic fluid penetrates skin, it

must be surgically removed as soon as possible by a doctor familiar with this form of injury or gangrene, serious injury, or death will result. **CONTACT A PHYSICIAN IMMEDIATELY IF FLUID ENTERS SKIN OR EYES. DO NOT DELAY.**

- Check that all hardware is properly installed. Always tighten to torque chart specifications unless instructed otherwise in this manual.
- Air in hydraulic systems can cause erratic operation and allows loads or equipment components to drop unexpectedly. When connecting equipment or hoses or performing any hydraulic maintenance, purge any air in hydraulic system by operating all hydraulic functions several times. Do this before putting into service or allowing anyone to approach the equipment.
- Protective hose sleeves must cover all hydraulic hoses within 20 inches of the operator and be secured onto metal hose fittings. Replace hoses or sleeves if damaged or if protective sleeve cannot be properly positioned or secured.
- Make sure all hydraulic hoses, fittings, and valves are in good condition and not leaking before starting power unit or using equipment. Check and route hoses carefully to prevent damage. Hoses must not be twisted, bent sharply, kinked, frayed, pinched, or come into contact with any moving parts. Operate moveable components through full operational range to check clearances. Replace any damaged hoses immediately.
- Always wear relatively tight and belted clothing to avoid getting caught in moving parts. Wear sturdy, rough-soled work shoes and protective equipment for eyes, hair, hands, hearing, and head; and respirator or filter mask where appropriate.
- Do not modify or alter or permit anyone else to modify or alter the equipment or any of its components in any way.
- Do not allow bystanders in the area when operating, attaching, removing, assembling, or servicing equipment.
- Use a suitable lifting device of sufficient capacity. Use adequate personnel to handle heavy components.
- Keep all persons away from operator control area while performing adjustments, service, or maintenance.

LOADER MOUNT INSTALLATION

Tractor Preparation

WARNING

■ Only use 211822 Loader Mounting Kit for mounting Woods 1020/1027 loaders on Massey Ferguson® 5425, 5435, 5445 or Challenger® MT425B, MT445B tractors. Any other use or modification of this mounting kit may result in serious injury or death.

IMPORTANT

■ This equipment must be assembled and installed on the customer's tractor by the Woods dealer. Dealer must thoroughly inspect equipment and complete each item on the PRE-DELIVERY CHECK LIST, DELIVERY CHECK LIST, and PRODUCT REGISTRATION from the Loader Manual before equipment is released to the customer.

■ Clean threaded holes in the tractor chassis thoroughly, using a tap of the proper size. Paint, rust or debris in the threads may not permit cap screws to be installed and tightened correctly.

For installing this mounting kit, references to right, left, forward, and rearward directions are determined from the operator's position in the tractor seat.

1. Shut off engine and set parking brake during installation.
2. Remove the tractor's front fenders if so equipped. Front fenders can not be used with loader.
3. Remove the tractor front weights and front weight bracket, if equipped.
4. Set front tire width to approximately 64". See Figure 1.

NOTE: Maximum front tires size for use with the 1020 or 1027 loader is 14.9R24.

5. Remove tool box from under right side of cab, if equipped.
6. Loosen steel bands from around fuel tank on left side of tractor and slide tank out away from tractor.
7. Remove hardware and spacers from the bottom of cab support brackets. See Figure 2. Save bolts for later use.

NOTE: The temporary removal of these parts will allow access to mounting areas on the tractor.

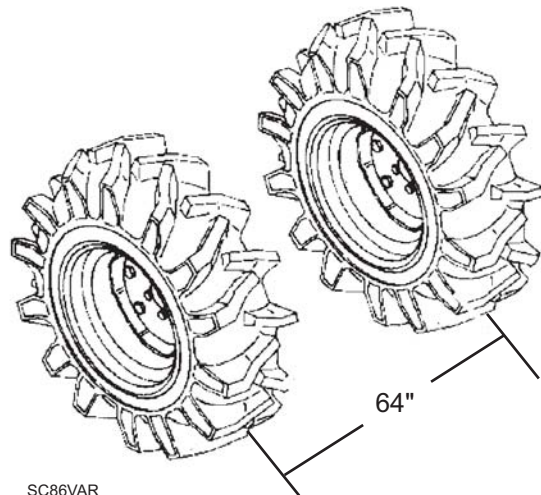

Figure 1. Tire Adjustment (FWA Models)

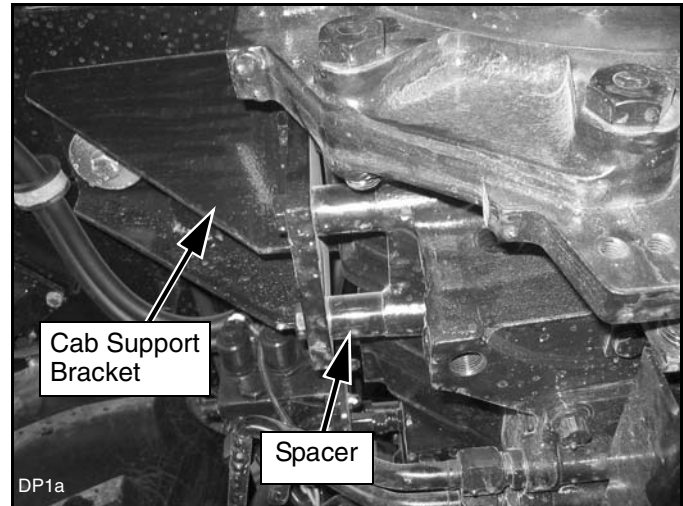

Figure 2. Right Cab Support Bracket, Bottom View

4 Mount Installation

MAN0469 (9/9/2005)

Install Right Rear Mount

1. Using a lifting device, place right mount (1) between cab support bracket and the tractor housing. Align holes and install tractor hardware previously removed. See Figure 3
2. Use two cap screws (5) and hardened flat washers (6) to secure right mount to tractor frame. See Figure 4.
3. Secure right mount to the bottom of transmission housing using one cap screw (4) and hardened flat washer (6). See Figure 5.
4. Attach crossmember (3) to the right mount using two cap screws (8), four hardened flat washers (9), and hex nuts (7). See Figure 6.

1. 1015400 Right mount
3. 1016216 Crossmember
4. 307550 M20 x 2.0P x 60 mm Cap screw
5. 307553 M20 x 2.5P x 50 mm Cap screw
6. 57798 3/4 Hardened flat washer
7. 307863 M16 x 2.0P Hex nut
8. 37863 M16 x 2.0P x 50 mm Cap screw
9. 57817 5/8 Hardened flat washer

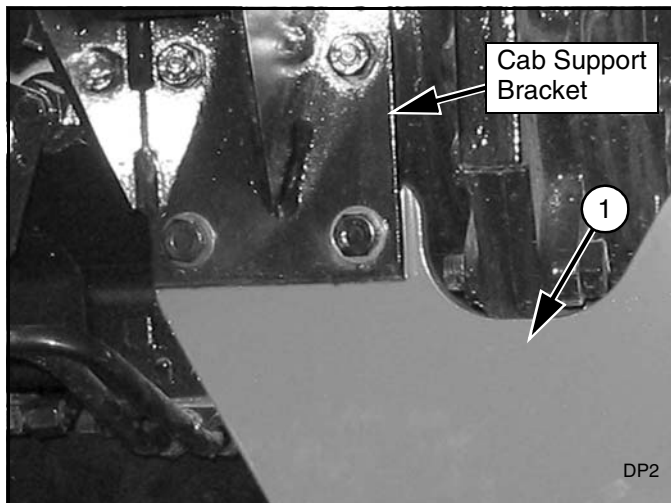

Figure 3. Right Rear Mount Installed, Cab Support

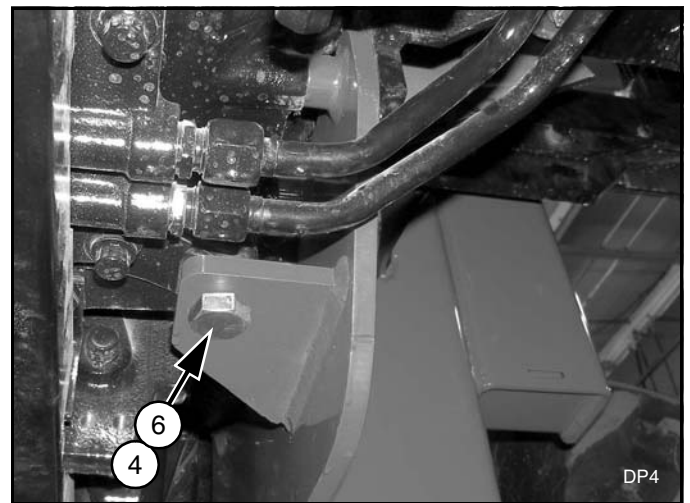

Figure 5. Right Rear Mount Installed, Bottom View

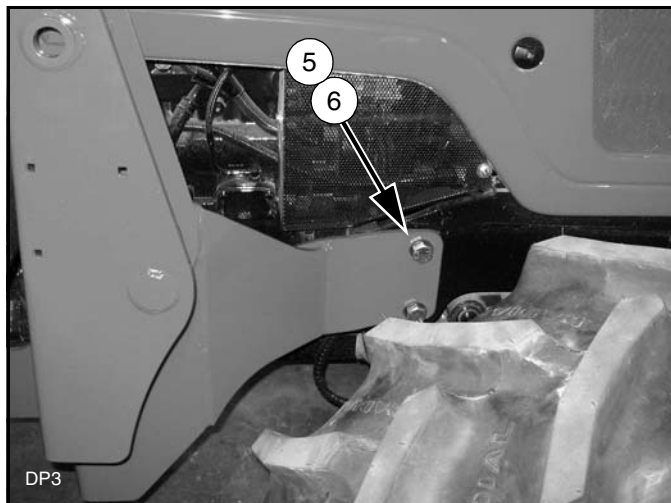

Figure 4. Right Rear Mount Installed, Tractor Frame

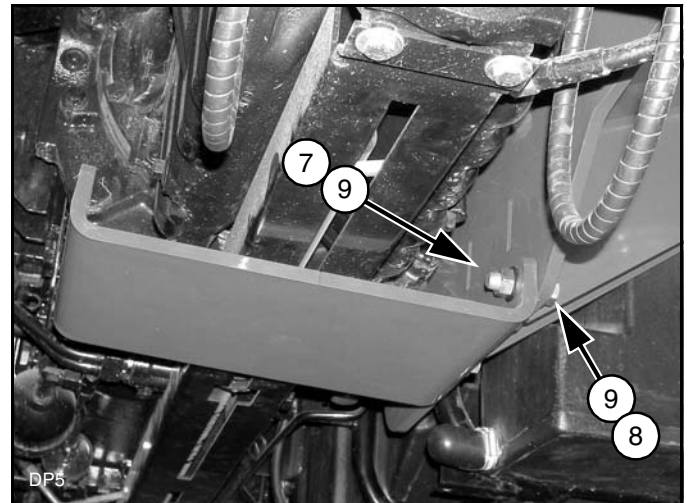

Figure 6. Crossmember to Rear Mount

Install Left Rear Mount

1. Using a lifting device, place left mount (2) between cab support bracket and the tractor housing. Align holes and install tractor hardware previously removed.

NOTE: Make sure fuel tank is moved out of the way to allow access to the cab support.

2. Secure left mount to tractor frame using two cap screws (5) and hardened flat washers (6).
3. Secure mount to bottom of transmission housing using one cap screw (4) and hardened flat washer (6).
4. Attach crossmember (3) to the left mount using two cap screws (8), four hardened flat washers (9), and hex nuts (7).



Figure 7. Left Rear Mount Installed

1. 1016200 Right mount
2. 1015401 Left mount
3. 1016216 Crossmember
4. 307550 M20 x 2.0P x 60 mm Cap screw
5. 307553 M20 x 2.5P x 50 mm Cap screw
6. 57798 3/4 Hardened flat washer
7. 307863 M16 x 2.0P Hex nut
8. 37863 M16 x 2.0P x 50 mm Cap screw
9. 57817 5/8 Hardened flat washer

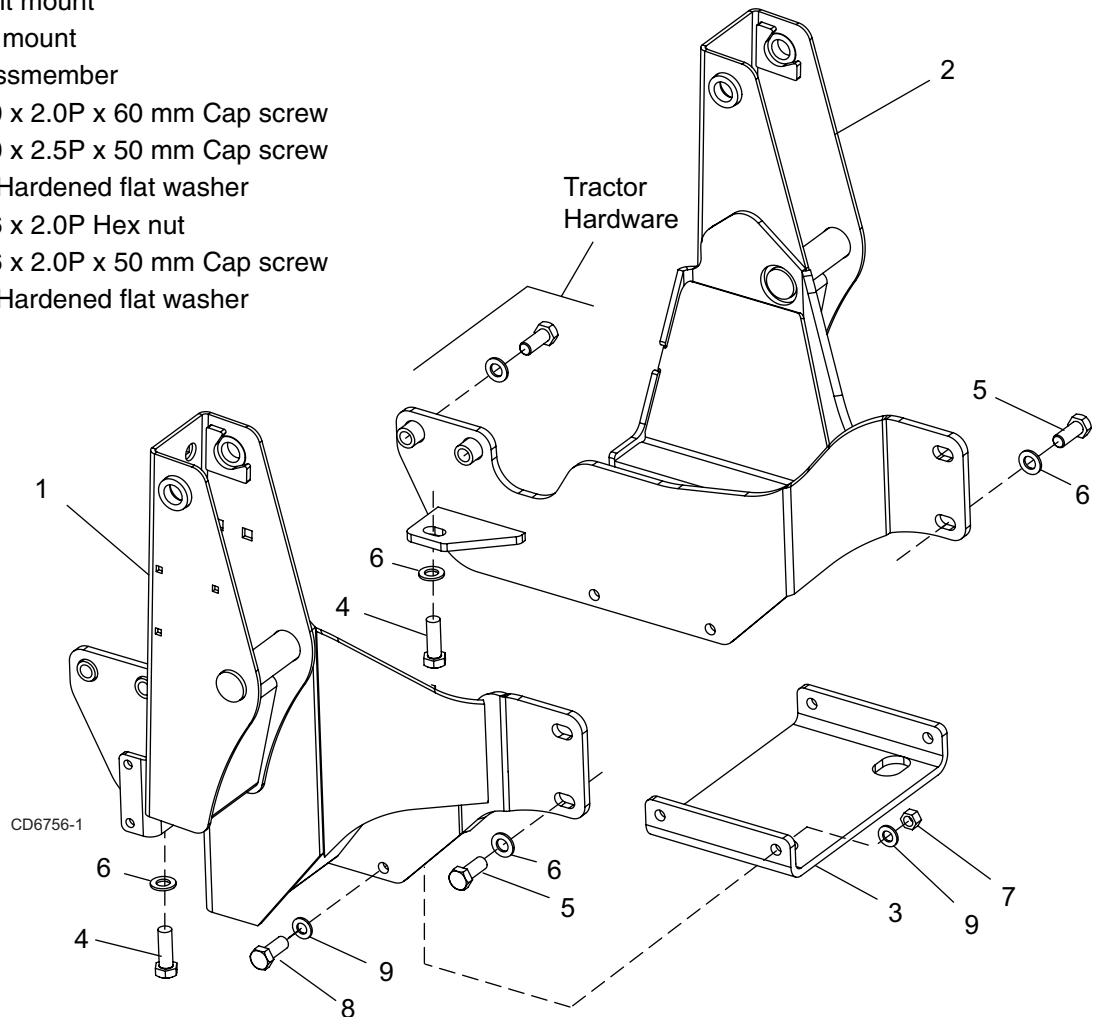

Figure 8. Rear Mount Installation

6 Mount Installation

MAN0469 (9/9/2005)

Torque Hardware

Torque hardware to specifications listed below.

Slide fuel tank back into position and secure.

TORQUE SPECIFICATIONS

Ref	Cap Screw	Qty	Wrench Size	Required Torque
4	M20 x 2.0P x 60 mm	2	30 mm	270 lbs-ft (367 N-m)
5	M20 x 2.5P x 50 mm	4	30 mm	270 lbs-ft (367 N-m)
8	M16 x 2.P x 50 mm	4	24 mm	125 lbs-ft (169 N-m)

Install Grill Guard (Optional)

1. Install grill guard bracket (10) to the right side of tractor frame in the lower set of holes using two cap screws (14), and hardened flat washers (17). Repeat for left side.
2. Place grill guard (11) between brackets (10) and secure using two cap screws (16) and four hex nuts (15). Secure hex nuts together but leave grill guard loose, it must be able to pivot freely. This allows the grill guard to swing down for maintenance.
3. Swing grill guard to the up position and secure using two clevis pins (12) and two klik pins (13).
4. Torque cap screws (14) to 270 lbs-ft.

10. 1015429 Grill guard bracket
11. 1015431 Grill guard
12. 21332 1/2 x 1-1/2 Clevis pin
13. 22411 3/16 x 1 Klik pin
14. 307553 M20 x 2.5P x 50 mm Cap screw
15. 307863 M16 x 2.0P Hex nut
16. 34766 M16 x 2.0P x 60 mm Cap screw
17. 57798 3/4 Hardened flat washer



Figure 9. Grill Guard Installed (Typical)

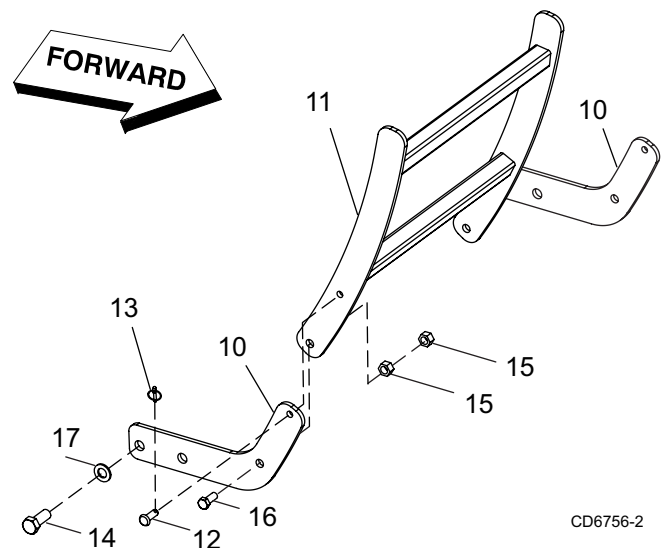

Figure 10. Grill Guard Installation

CD6756-2

Install Oscillation Stops

1. Locate the oscillation stops on left and right sides of the front axle.
2. Remove oscillation stop, place two washers (6) between stop and mounting pad, and replace oscillation stop.
3. Secure using tractor hardware.
4. Repeat for opposite side of tractor.

6. 57798 3/4 Hardened flat washer

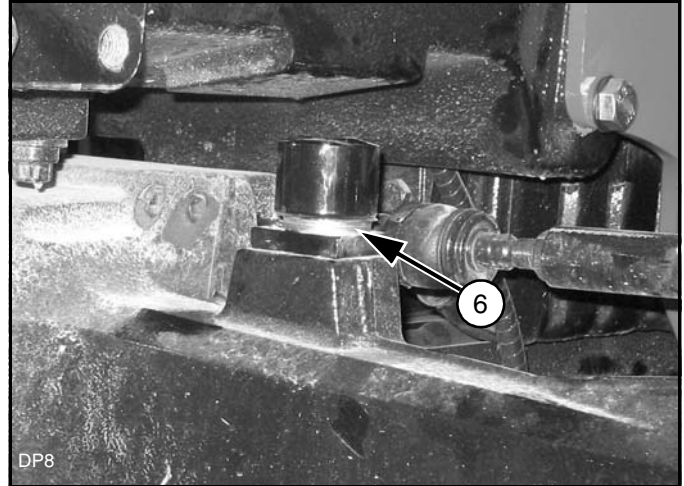

Figure 11. Oscillation Stop Installed - Left Side

As a valued customer, Woods appreciates your comments. Once loader mount and hydraulic hoses have been installed, please take a few minutes to complete the Loader Mount Evaluation sheet that was supplied with your loader mount. Your comments will help us continue to bring you quality products.

57988 HOSE KIT INSTALLATION

WARNING

- Keep hands and body away from pressurized lines. Use paper or cardboard, not hands or other body parts to check for leaks. Wear safety goggles. Hydraulic fluid under pressure can easily penetrate skin and will cause serious injury or death.
- Make sure that all operating and service personnel know that if hydraulic fluid penetrates skin, it must be surgically removed as soon as possible by a doctor familiar with this form of injury or gangrene, serious injury, or death will result. **CONTACT A PHYSICIAN IMMEDIATELY IF FLUID ENTERS SKIN OR EYES. DO NOT DELAY.**
- Air in hydraulic systems can cause erratic operation and allows loads or equipment components to drop unexpectedly. When connecting equipment or hoses or performing any hydraulic maintenance, purge any air in hydraulic system by operating all hydraulic functions several times. Do this before putting into service or allowing anyone to approach the equipment.

WARNING

- Protective hose sleeves must cover all hydraulic hoses within 20 inches of the operator and be secured onto metal hose fittings. Replace hoses or sleeves if damaged or if protective sleeve cannot be properly positioned or secured.
- Make sure all hydraulic hoses, fittings, and valves are in good condition and not leaking before starting power unit or using equipment. Check and route hoses carefully to prevent damage. Hoses must not be twisted, bent sharply, kinked, frayed, pinched, or come into contact with any moving parts. Operate moveable components through full operational range to check clearances. Replace any damaged hoses immediately.

General Description

These set-up instructions are for operating the loader using the tractor hydraulic remote control levers. To use this connection, the tractor must be equipped with two hydraulic levers (Figure 12) and four tractor hydraulic couplers.

NOTE: The male hydraulic quick couplers for connection to tractor are NOT INCLUDED with this hose kit but are available as service parts.

NOTE: Not all parts supplied with this hose kit will be used with this tractor.



Figure 12. Hydraulic Control Levers (Cab Tractor)

Assemble Hoses

1. Attach a 90° elbow (2) and male quick coupler (3) to each loader supply hose (1). See Figure 13.
2. Connect loader supply hoses to loader feedlines as shown in Figure 14.

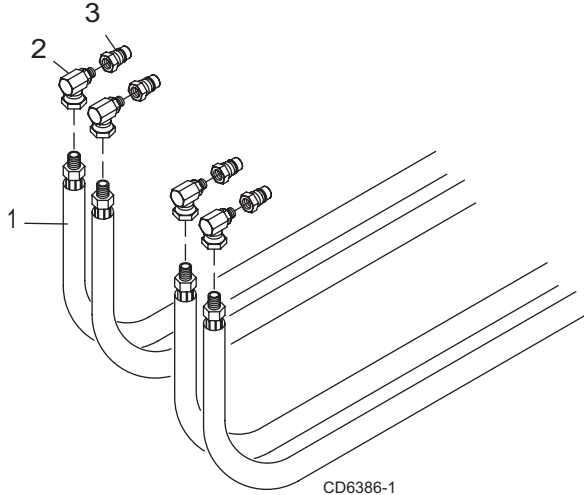
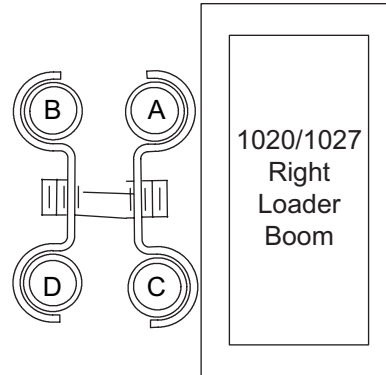

Figure 13. Hose Assembly

1. 53670 Hose, 150" x 3/4 JICM x 3/4 JICM
2. 313053 Elbow, 3/4 JICF x 1/2 NPTM
3. 66511 Quick coupler, male 1/2 NPT (not included in kit)



LOADER FEEDLINES

Figure 14. 1020/1027 Loader Feedline Connections

Install Hose Hanger

Attach hose hanger (4) to frame rail under right side of cab. Secure into position using cap screw (6), flat washer (7), and hex nut (8).

4. 58033 Hose hanger
5. 58047 1/4 x 2-1/2 Lock pin
6. 30577 M8 x 1.25P x 25 mm Cap screw
7. 4378 5/16 Flat washer
8. 30515 M8 x 1.25P Hex nut

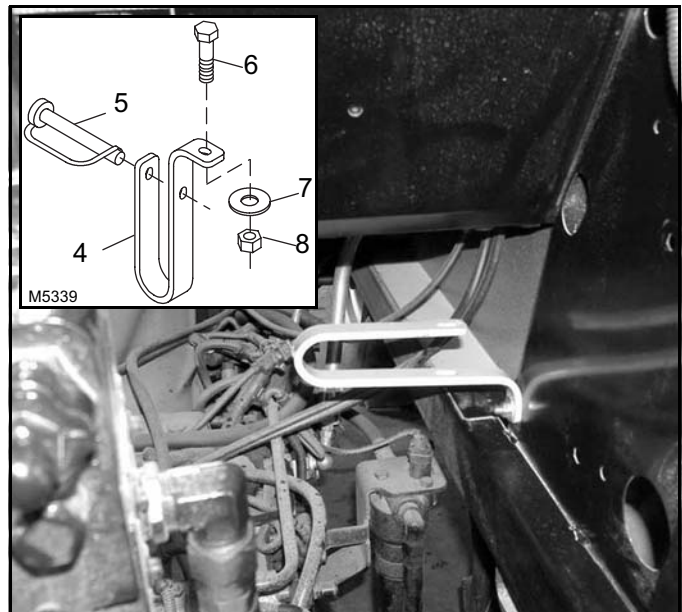

Figure 15. Hose Hanger Installed

Route Hoses

1. Route hoses along right mount, between cab and tractor exhaust, under cab, and over right rear axle. See Figure 16
2. Place hoses in hose hanger (4) (Figure 17) and secure using lock pin (5).
3. Be sure to avoid contact with 3-point linkage, brake pedals, and other moveable tractor components.
4. Hoses must be routed so that they are not pinched, bent sharply, or chafed during operation. Hoses must not interfere with any tractor control operation or contact any moving parts.
5. Connect hoses to tractor remote couplers. See Figure 18 and Figure 19.

4. 58033 Hose hanger
5. 58047 1/4 x 2-1/2 Lock pin
(not shown in picture)

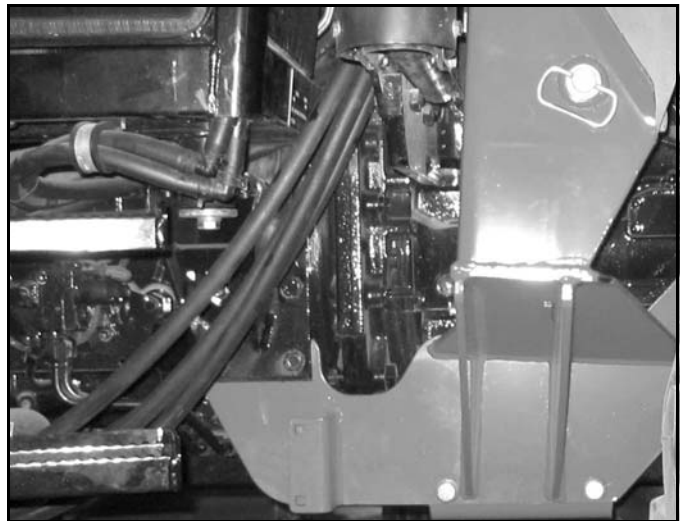

Figure 16. Hose Routing

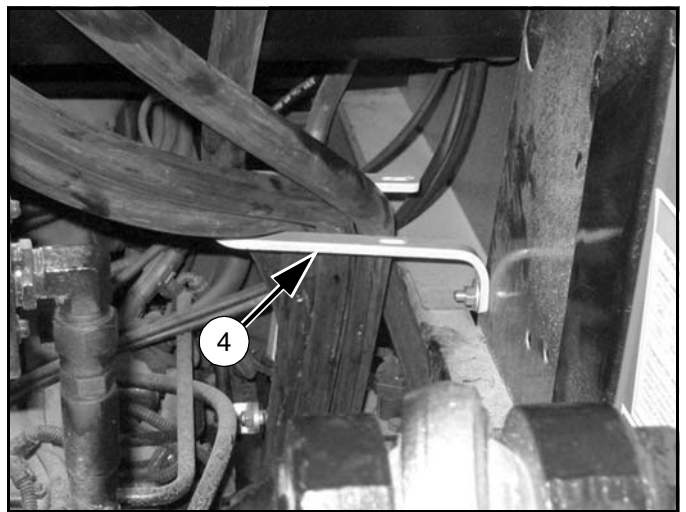

Figure 17. Hose Hanger

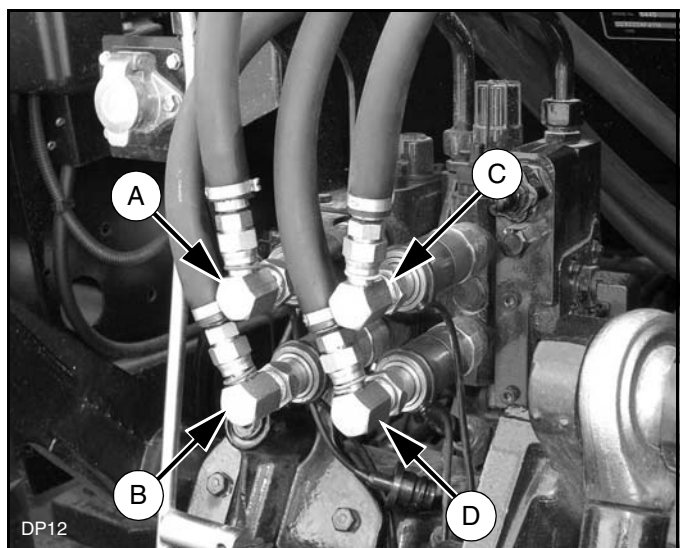
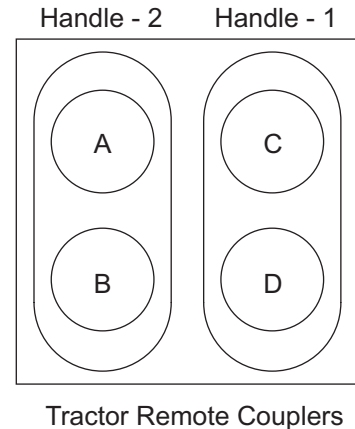

Figure 18. Hose Connection to Tractor

Verify Control Movements

- 1. Mount loader to tractor:** Remove mount pins from loader uprights. Align tractor with loader and slowly drive tractor into loader. Shut off tractor.
- 2. Connect loader feedline hoses to tractor remote control couplers.** See Figure 18 and Figure 19.
- 3. Comply with all safety rules and start the tractor.**
- 4. Mount loader to tractor by activating bucket cylinders to raise or lower the loader uprights into the loader mounts.** Slowly advance tractor forward, activating appropriate cylinders to engage loader completely into mounts. Insert mounting pins to secure loader.
- 5. Check that all tractor hydraulic control lever positions operate the loader movements correctly.** See Figure 20.
- 6. If loader movements do not respond correctly,** shut off tractor, relieve pressure, and reconnect properly. Loader control movements must be correct before proceeding.
- 7. Once all loader functions are correct,** start the tractor and operate the loader to check for leaks. Purge any remaining air from the hydraulic system and check oil level.
- 8. When hose routings and correct loader operations are verified,** identify each circuit by placing a matching colored band around the male and female quick-disconnect coupler. The color-coded bands will make reinstallation easier when the loader is removed from tractor.
- 9. Attach the plastic tie straps (included in kit) every 20-inches** around the hoses to keep them tightly bundled and away from contact with the ground or other moving parts on the tractor or loader.
- 10. Before operating the loader,** make sure that the Pre-Delivery, Delivery, and Pre-Operation Check Lists from the Loader Operator's Manual have been completed.



- A - BUCKET CYL. BASE END (DUMP)
- B - BUCKET CYL. ROD END (ROLLBACK)
- C - BOOM CYL. ROD END (DOWN)
- D - BOOM CYL. BASE END (UP)

LA6

Figure 19. Loader Feedline Connections

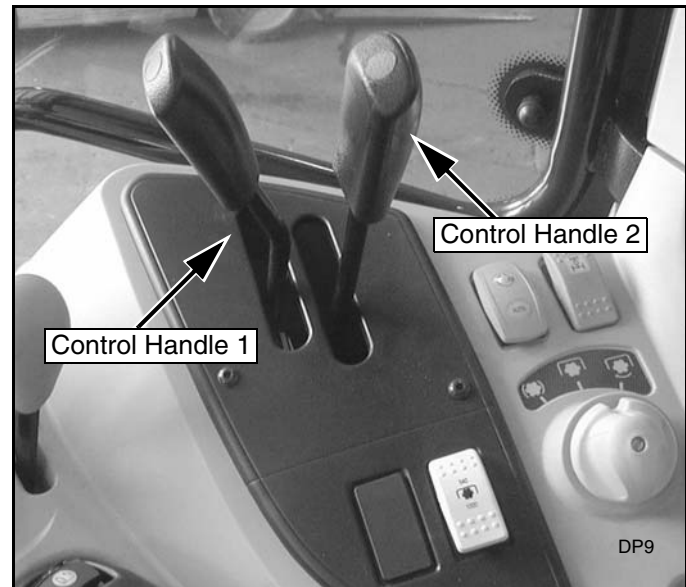

- Control 1, Handle forward - Boom down
- Control 1, Handle back - Boom up
- Control 2, Handle forward - Dump bucket or attachment
- Control 2, Handle back - Rollback bucket or attachment

Figure 20. Two Handle Hydraulic Control Levers

211822 LOADER MOUNTING KIT

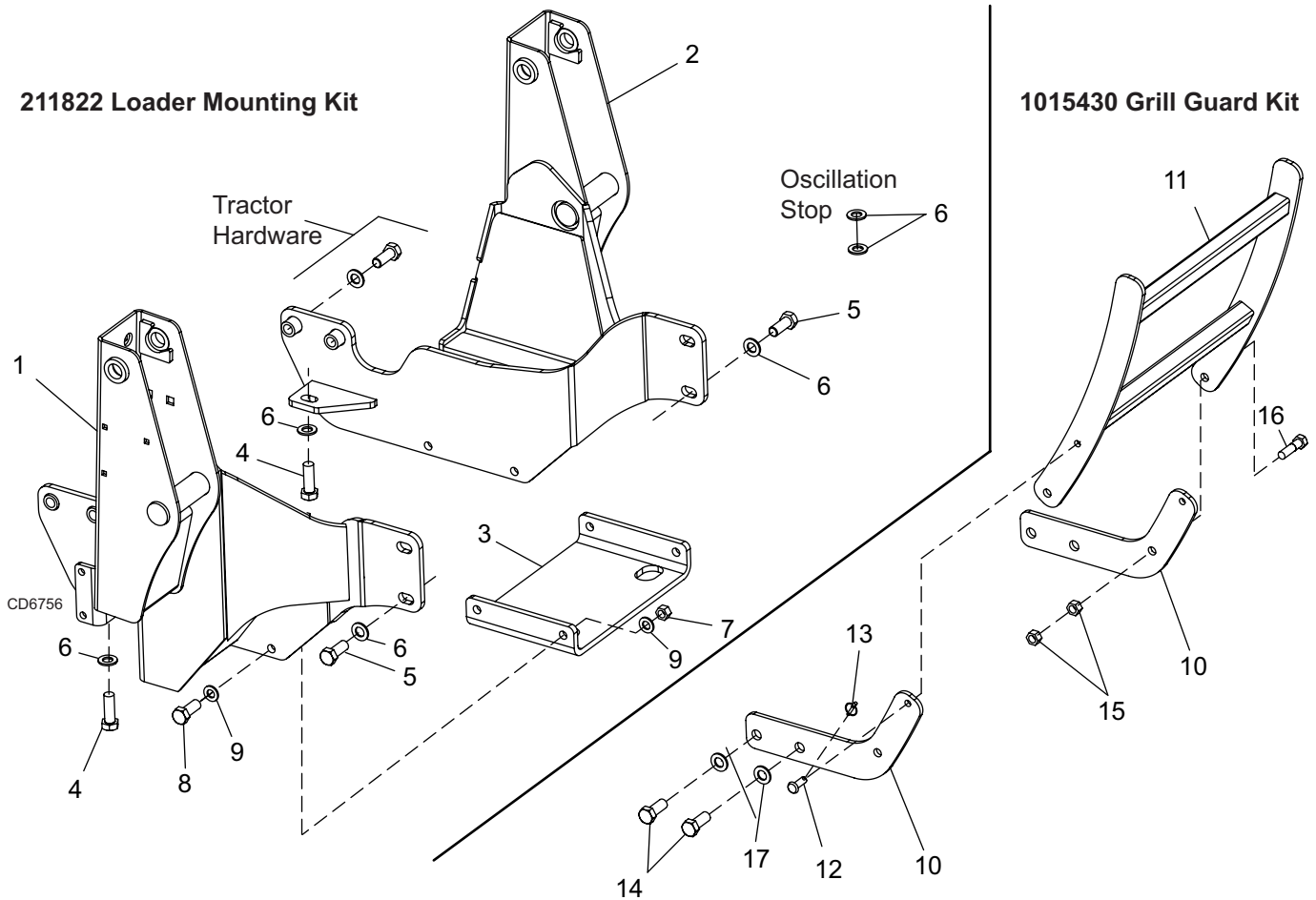

211822 LMK Parts

REF	PART	QTY	DESCRIPTION
1	1015400	1	Right rear mount
2	1015401	1	Left rear mount
3	1016216	1	Crossmember
4	307550	2	M20 x 2.0P x 60 mm Cap screw
5	307553	10	M20 x 2.5P x 50 mm Cap screw
6	57798	10	3/4 Hardened flat washer
7	307863	4	M16 x 2.0P Hex nut
8	37863	4	M16 x 2.0P x 50 mm Cap screw
9	57817	8	5/8 Hardened flat washer

1015430 Grill Guard Kit (Optional)

REF	PART	QTY	DESCRIPTION
10	1015429	2	Grill guard bracket
11	-----	1	Grill guard (not sold separately)
12	21332	2	1/2 x 1-1/2 Clevis pin
13	22411	2	3/16 x 1 Kilk pin
14	307553	4	M20 x 2.5P x 50 mm Cap screw
15	307863	4	M16 x 2.0P Hex nut
16	34766	2	M16 x 2.0P x 60 mm Cap screw
17	57798	4	3/4 Hardened flat washer

57988 HOSE KIT

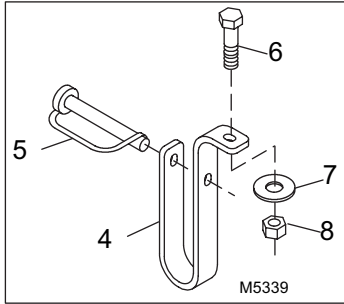

Connect to
Loader Boom
Steel Feedlines

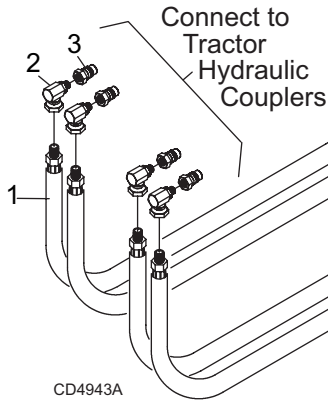

NOTE: Not all parts supplied with this hose kit are used for this application.

REF	PART	QTY	DESCRIPTION
1	53670	4	Hose, 150" x 3/4 JICM x 3/4 JICM
2	313053	4	Elbow, 3/4 JICF x 1/2 NPTM
3	66511	4	Quick coupler, male 1/2 NPT (not included in kit)
4	58033	1	Hose hanger
5	58047	1	1/4 x 2-1/2 Lock pin
6	30577	1	M8 x 1.25P x 25 mm Cap screw
7	4378 *	1	5/16 Flat washer
8	30515	1	M8 x 1.25P Hex nut
NS	395061	2	Plastic band, red
NS	395062	2	Plastic band, blue
NS	56061	2	Plastic band, green
NS	56062	2	Plastic band, yellow
NS	88 *	7	Plastic tie (as required)

NS Not shown

* Standard hardware, obtain locally

14 Parts

MAN0469 (9/9/2005)

BOLT TORQUE CHART

Always tighten hardware to these values unless a different torque value or tightening procedure is listed for a specific application.

Fasteners must always be replaced with the same grade as specified in the manual parts list.

Always use the proper tool for tightening hardware: SAE for SAE hardware and Metric for metric hardware.

Make sure fastener threads are clean and you start thread engagement properly.

All torque values are given to specifications used on hardware defined by SAE J1701 MAR 99 & J1701M JUL 96.

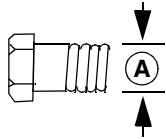

SAE SERIES TORQUE CHART

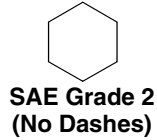

SAE Bolt Head Identification



A Diameter (Inches)	Wrench Size	MARKING ON HEAD					
		SAE 2		SAE 5		SAE 8	
		lbs-ft	N-m	lbs-ft	N-m	lbs-ft	N-m
1/4"	7/16"	6	8	10	13	14	18
5/16"	1/2"	12	17	19	26	27	37
3/8"	9/16"	23	31	35	47	49	67
7/16"	5/8"	36	48	55	75	78	106
1/2"	3/4"	55	75	85	115	120	163
9/16"	13/16"	78	106	121	164	171	232
5/8"	15/16"	110	149	170	230	240	325
3/4"	1-1/8"	192	261	297	403	420	569
7/8"	1-5/16"	306	416	474	642	669	907
1"	1-1/2"	467	634	722	979	1020	1383

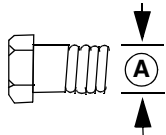

METRIC SERIES TORQUE CHART

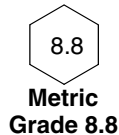

Metric Bolt Head Identification

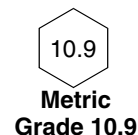

A Diameter & Thread Pitch (Millimeters)	Wrench Size	COARSE THREAD				FINE THREAD				A Diameter & Thread Pitch (Millimeters)
		MARKING ON HEAD								
		Metric 8.8		Metric 10.9		Metric 8.8		Metric 10.9		
		N-m	lbs-ft	N-m	lbs-ft	N-m	lbs-ft	N-m	lbs-ft	
6 x 1.0	10 mm	8	6	11	8	8	6	11	8	6 x 1.0
8 x 1.25	13 mm	20	15	27	20	21	16	29	22	8 x 1.0
10 x 1.5	16 mm	39	29	54	40	41	30	57	42	10 x 1.25
12 x 1.75	18 mm	68	50	94	70	75	55	103	76	12 x 1.25
14 x 2.0	21 mm	109	80	151	111	118	87	163	120	14 x 1.5
16 x 2.0	24 mm	169	125	234	173	181	133	250	184	16 x 1.5
18 x 2.5	27 mm	234	172	323	239	263	194	363	268	18 x 1.5
20 x 2.5	30 mm	330	244	457	337	367	270	507	374	20 x 1.5
22 x 2.5	34 mm	451	332	623	460	495	365	684	505	22 x 1.5
24 x 3.0	36 mm	571	421	790	583	623	459	861	635	24 x 2.0
30 x 3.0	46 mm	1175	867	1626	1199	1258	928	1740	1283	30 x 2.0

Typical Washer Installations

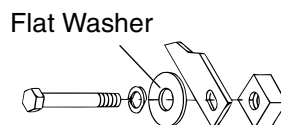
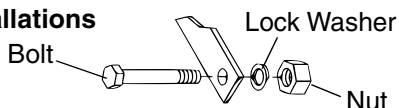

8/9/00

BOLT SIZE CHART

NOTE: Chart shows bolt thread sizes and corresponding head (wrench) sizes for standard SAE and metric bolts.

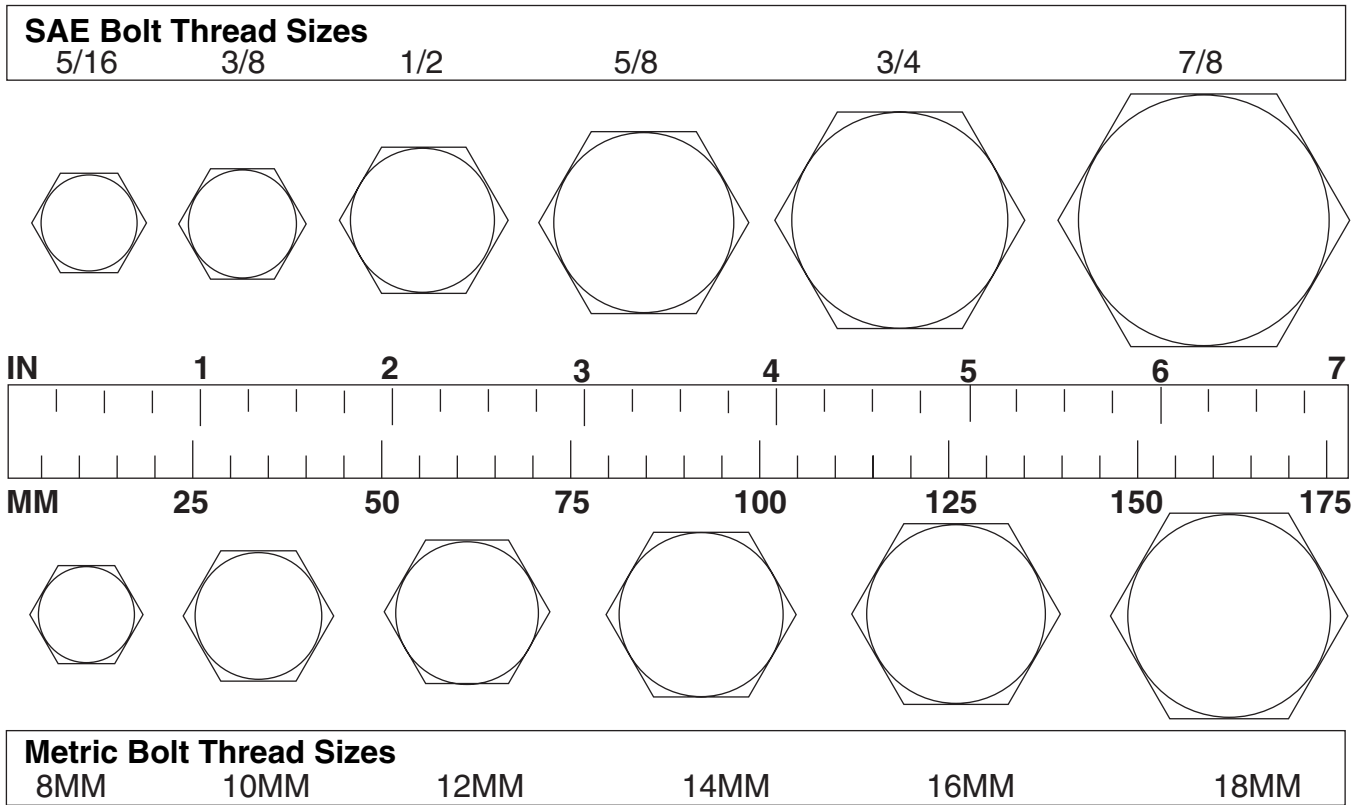

ABBREVIATIONS

AGAgriculture
 ATF Automatic Transmission Fluid
 BSPP British Standard Pipe Parallel
 BSPTM British Standard Pipe Tapered Male
 CV Constant Velocity
 CCW Counter-Clockwise
 CW Clockwise
 F Female
 GA Gauge
 GR (5, etc.) Grade (5, etc.)
 HHCS Hex Head Cap Screw
 HT Heat-Treated
 JIC Joint Industry Council 37° Degree Flare
 LH Left Hand
 LT Left
 m Meter
 mm Millimeter
 M Male
 MPa Mega Pascal
 N Newton

NC National Coarse
 NF National Fine
 NPSM National Pipe Straight Mechanical
 NPT National Pipe Tapered
 NPT SWF National Pipe Tapered Swivel Female
 ORBM O-Ring Boss - Male
 P Pitch
 PBY Power-Beyond
 psi Pounds per Square Inch
 PTO Power Take Off
 QD Quick Disconnect
 RH Right Hand
 ROPS Roll-Over Protective Structure
 RPM Revolutions Per Minute
 RT Right
 SAE Society of Automotive Engineers
 UNC Unified Coarse
 UNF Unified Fine
 UNS Unified Special



WARRANTY

(All Models Except Mow'n Machine™ Zero-Turn Mowers and Woods Boundary™ Utility Vehicles)

Please Enter Information Below and Save for Future Reference.

Date Purchased: _____

From (Dealer): _____

Model Number: _____

Serial Number: _____

Woods Equipment Company ("WOODS") warrants this product to be free from defect in material and workmanship. Except as otherwise set forth below, the duration of this Warranty shall be for TWELVE (12) MONTHS COMMENCING ON THE DATE OF DELIVERY OF THE PRODUCT TO THE ORIGINAL PURCHASER.

The warranty periods for certain gearboxes are listed below:

Model No.	Part Warranted	Duration
PHD25, PHD35, PHD65, PHD95, 1260, 2120, 2162, 3180, 3240, BB48, BB60, BB72, BB84, BB600, BB720, BB840, BB6000, BB7200, BB8400, BW180, DS96, DS120, RCC42, RM550-2, RM660-2, RM990-3, RD6000-2, RD7200-2, RD8400-2, 7144RD-2, 9180RD-2, 9204RD-2	Gearbox components	5 years from the date of delivery to the original purchaser.
RDC54, RD60, RD72	Gearbox components	3 years from the date of delivery to the original purchaser.
BW180, DS96, DS120, RDC54, RD60, RD72	Gearbox components	1 year from the date of delivery to the original purchaser if used in rental or commercial applications.

Under no circumstances will this Warranty apply in the event that the product, in the good faith opinion of WOODS, has been subjected to improper operation, improper maintenance, misuse, or an accident. This Warranty does not apply in the event that the product has been materially modified or repaired by someone other than WOODS, a WOODS authorized dealer or distributor, and/or a WOODS authorized service center. This Warranty does not cover normal wear or tear, or normal maintenance items. This Warranty also does not cover repairs made with parts other than those obtainable through WOODS.

This Warranty is extended solely to the original purchaser of the product. Should the original purchaser sell or otherwise transfer this product to a third party, this Warranty does not transfer to the third party purchaser in any way. There are no third party beneficiaries of this Warranty.

WOODS makes no warranty, express or implied, with respect to engines, batteries, tires or other parts or accessories not manufactured by WOODS. Warranties for these items, if any, are provided separately by their respective manufacturers.

WOODS' obligation under this Warranty is limited to, at WOODS' option, the repair or replacement, free of charge, of the product if WOODS, in its sole discretion, deems it to be defective or in noncompliance with this Warranty. **The product must be returned to WOODS with proof of purchase within thirty (30) days after such defect or noncompliance is discovered or should have been discovered, routed through the dealer and distributor from whom the purchase was made, transportation charges prepaid.** WOODS shall complete such repair or replacement within a reasonable time after WOODS receives the product. THERE ARE NO OTHER REMEDIES UNDER THIS WARRANTY. THE REMEDY OF REPAIR OR REPLACEMENT IS THE SOLE AND EXCLUSIVE REMEDY UNDER THIS WARRANTY.

THERE ARE NO WARRANTIES WHICH EXTEND BEYOND THE DESCRIPTION ON THE FACE OF THIS WARRANTY. WOODS MAKES NO OTHER WARRANTY, EXPRESS OR IMPLIED, AND WOODS SPECIFICALLY DISCLAIMS ANY IMPLIED WARRANTY OF MERCHANTABILITY AND/OR ANY IMPLIED WARRANTY OF FITNESS FOR A PARTICULAR PURPOSE.

WOODS shall not be liable for any incidental or consequential losses, damages or expenses, arising directly or indirectly from the product, whether such claim is based upon breach of contract, breach of warranty, negligence, strict liability in tort or any other legal theory. Without limiting the generality of the foregoing, Woods specifically disclaims any damages relating to (i) lost profits, business, revenues or goodwill; (ii) loss of crops; (iii) loss because of delay in harvesting; (iv) any expense or loss incurred for labor, supplies, substitute machinery or rental; or (v) any other type of damage to property or economic loss.

This Warranty is subject to any existing conditions of supply which may directly affect WOODS' ability to obtain materials or manufacture replacement parts.

No agent, representative, dealer, distributor, serviceperson, salesperson, or employee of any company, including without limitation, WOODS, its authorized dealers, distributors, and service centers, is authorized to alter, modify, or enlarge this Warranty.

Answers to any questions regarding warranty service and locations may be obtained by contacting:

Woods Equipment Company

2606 South Illinois Route 2
Post Office Box 1000
Oregon, Illinois 61061

815-732-2141 tel
815-732-7580 fax
www.WoodsEquipment.com



ALITEC™

BMP®

CENTRAL FABRICATORS®

GANNON®

GILL®

WAIN-ROY®

WOODS®



WARRANTY

(Replacement Parts For All Models Except Mow'n Machine™
Zero-Turn Mowers and Woods Boundary™ Utility Vehicles)

Woods Equipment Company ("WOODS") warrants this product to be free from defect in material and workmanship for a period of ninety (90) days from the date of delivery of the product to the original purchaser with the exception of V-belts, which will be free of defect in material and workmanship for a period of 12 months.

Under no circumstances will this Warranty apply in the event that the product, in the good faith opinion of WOODS, has been subjected to improper operation, improper maintenance, misuse, or an accident. This Warranty does not cover normal wear or tear, or normal maintenance items.

This Warranty is extended solely to the original purchaser of the product. Should the original purchaser sell or otherwise transfer this product to a third party, this Warranty does not transfer to the third party purchaser in any way. There are no third party beneficiaries of this Warranty.

WOODS' obligation under this Warranty is limited to, at WOODS' option, the repair or replacement, free of charge, of the product if WOODS, in its sole discretion, deems it to be defective or in noncompliance with this Warranty. **The product must be returned to WOODS with proof of purchase within thirty (30) days after such defect or noncompliance is discovered or should have been discovered, routed through the dealer and distributor from whom the purchase was made, transportation charges prepaid.** WOODS shall complete such repair or replacement within a reasonable time after WOODS receives the product. THERE ARE NO OTHER REMEDIES UNDER THIS WARRANTY. THE REMEDY OF REPAIR OR REPLACEMENT IS THE SOLE AND EXCLUSIVE REMEDY UNDER THIS WARRANTY.

THERE ARE NO WARRANTIES WHICH EXTEND BEYOND THE DESCRIPTION ON THE FACE OF THIS WARRANTY. WOODS MAKES NO OTHER WARRANTY, EXPRESS OR IMPLIED, AND WOODS SPECIFICALLY DISCLAIMS ANY IMPLIED WARRANTY OF MERCHANTABILITY AND/OR ANY IMPLIED WARRANTY OF FITNESS FOR A PARTICULAR PURPOSE.

WOODS shall not be liable for any incidental or consequential losses, damages or expenses, arising directly or indirectly from the product, whether such claim is based upon breach of contract, breach of warranty, negligence, strict liability in tort or any other legal theory. Without limiting the generality of the foregoing, Woods specifically disclaims any damages relating to (i) lost profits, business, revenues or goodwill; (ii) loss of crops; (iii) loss because of delay in harvesting; (iv) any expense or loss incurred for labor, supplies, substitute machinery or rental; or (v) any other type of damage to property or economic loss.

This Warranty is subject to any existing conditions of supply which may directly affect WOODS' ability to obtain materials or manufacture replacement parts.

No agent, representative, dealer, distributor, service person, salesperson, or employee of any company, including without limitation, WOODS, its authorized dealers, distributors, and service centers, is authorized to alter, modify, or enlarge this Warranty.

Answers to any questions regarding warranty service and locations may be obtained by contacting:

Woods Equipment Company

2606 South Illinois Route 2
Post Office Box 1000
Oregon, Illinois 61061

815-732-2141 tel
815-732-7580 fax
www.WoodsEquipment.com

ALITEC™

BMP®

CENTRAL FABRICATORS®

GANNON®

GILL®

WAIN-ROY®

WOODS®

Free Manuals Download Website

<http://myh66.com>

<http://usermanuals.us>

<http://www.somanuals.com>

<http://www.4manuals.cc>

<http://www.manual-lib.com>

<http://www.404manual.com>

<http://www.luxmanual.com>

<http://aubethermostatmanual.com>

Golf course search by state

<http://golfingnear.com>

Email search by domain

<http://emailbydomain.com>

Auto manuals search

<http://auto.somanuals.com>

TV manuals search

<http://tv.somanuals.com>