

# WOODS

## 2300012 LOADER MOUNTING KIT

for LUP126-2, LUP132-2 Loaders

on New Holland® Tractors  
T5040, T5050, T5060, T5070  
2WD & FWA

or Case IH® Tractors  
Farmall® 85U, Farmall 95U, Farmall 105U  
2WD & FWA

includes Hose Kits  
58025, 1028835

**MAN0788**

(1/16/2009)



**WOODS®**

INSTALLATION MANUAL

## TO THE DEALER:

Assembly and proper installation of this product is the responsibility of the Woods® dealer. Read manual instructions and safety rules. Make sure all items on the Dealer's Pre-Delivery and Delivery Check Lists in the Loader Operator's Manual are completed before releasing equipment to the owner.

## TO THE OWNER:

Read this manual and Loader Operator's Manual before operating your Woods equipment. The information presented will prepare you to do a better and safer job. Keep this manual handy for ready reference. Require all operators to read this manual carefully and become acquainted with all adjustment and operating procedures before attempting to operate. Replacement manuals can be obtained from your dealer. To locate your nearest dealer, check the Dealer Locator at [www.WoodsEquipment.com](http://www.WoodsEquipment.com), or in the United States and Canada call 1-800-319-6637.

The equipment you have purchased has been carefully engineered and manufactured to provide dependable and satisfactory use. Like all mechanical products, it will require cleaning and upkeep. Lubricate the unit as specified. Observe all safety information in this manual and safety decals on the equipment.

For service, your authorized Woods dealer has trained mechanics, genuine Woods service parts, and the necessary tools and equipment to handle all your needs.

Use only genuine Woods service parts. Substitute parts will void the warranty and may not meet standards required for safe and satisfactory operation. Record the model number of your equipment in the space provided.

**Model:** \_\_\_\_\_

**Date of Purchase:** \_\_\_\_\_

Provide this information to your dealer to obtain correct repair parts.

Throughout this manual, the term **NOTICE** is used to indicate that failure to observe can cause damage to equipment. The terms **CAUTION**, **WARNING**, and **DANGER** are used in conjunction with the Safety-Alert Symbol (a triangle with an exclamation mark) to indicate the degree of hazard for items of personal safety.



This is the safety alert symbol. It is used to alert you to potential personal injury hazards. Obey all safety messages that follow this symbol to avoid possible injury or death.



Indicates a hazardous situation which, if not avoided, will result in death or serious injury.



Indicates a hazardous situation which, if not avoided, could result in death or serious injury.



Indicates a hazardous situation which, if not avoided, could result in minor or moderate injury.

**IMPORTANT  
or NOTICE**

Is used to address practices not related to personal injury.

**NOTE**

Indicates helpful information.

**WOODS®**

**ALITEC™**  
**BMP®**  
**CENTRAL FABRICATORS®**  
**GANNON®**  
**GILL®**  
**WAIN-ROY®**  
**WOODS®**

## 2 Introduction

LMK (Rev. 7/20/2007)



# SAFETY RULES

**ATTENTION! BECOME ALERT! YOUR SAFETY IS INVOLVED!**



## ¡LEA EL INSTRUCTIVO!

Si no lee Ingles, pida ayuda a alguien que si lo lea para que le traduzca las medidas de seguridad.

Safety is a primary concern in the design and manufacture of our products. Unfortunately, our efforts to provide safe equipment can be wiped out by an operator's single careless act.

In addition to the design and configuration of equipment, hazard control and accident prevention are dependent upon the awareness, concern, judgement, and proper training of personnel involved in the operation, transport, maintenance, and storage of equipment.

It has been said, "The best safety device is an informed, careful operator." We ask you to be that kind of operator.

## **INSTALLATION**

- This Loader Mounting Kit is to be used only for the loaders and tractors specified in this manual. Any other use or modification of this mounting kit may result in serious injury or death.
- Hydraulics must be connected as instructed in this manual. Do not substitute parts, modify, or connect in any other way.
- After connecting hoses, check that all control lever positions function as instructed in the Operator's Manual. Do not put into service until control lever and equipment movements are correct.
- Safety instructions are important! Read all attachment and power unit manuals; follow all safety rules and safety decal information. (Replacement manuals and safety decals are available from your dealer. To locate your nearest dealer, check the Dealer Locator at [www.WoodsEquipment.com](http://www.WoodsEquipment.com), or in the United States and Canada call 1-800-319-6637.) Failure to follow instructions or safety rules can result in serious injury or death.
- Keep hands and body away from pressurized lines. Use paper or cardboard, not hands or other body parts to check for leaks. Wear safety goggles. Hydraulic fluid under pressure can easily penetrate skin and will cause serious injury or death.
- Make sure that all operating and service personnel know that if hydraulic fluid penetrates skin, it

must be surgically removed as soon as possible by a doctor familiar with this form of injury or gangrene, serious injury, or death will result. **CONTACT A PHYSICIAN IMMEDIATELY IF FLUID ENTERS SKIN OR EYES. DO NOT DELAY.**

- Check that all hardware is properly installed. Always tighten to torque chart specifications unless instructed otherwise in this manual.
- Air in hydraulic systems can cause erratic operation and allows loads or equipment components to drop unexpectedly. When connecting equipment or hoses or performing any hydraulic maintenance, purge any air in hydraulic system by operating all hydraulic functions several times. Do this before putting into service or allowing anyone to approach the equipment.
- Protective hose sleeves must cover all hydraulic hoses within 20 inches of the operator and be secured onto metal hose fittings. Replace hoses or sleeves if damaged or if protective sleeve cannot be properly positioned or secured.
- Make sure all hydraulic hoses, fittings, and valves are in good condition and not leaking before starting power unit or using equipment. Check and route hoses carefully to prevent damage. Hoses must not be twisted, bent sharply, kinked, frayed, pinched, or come into contact with any moving parts. Operate moveable components through full operational range to check clearances. Replace any damaged hoses immediately.
- Always wear relatively tight and belted clothing to avoid getting caught in moving parts. Wear sturdy, rough-soled work shoes and protective equipment for eyes, hair, hands, hearing, and head; and respirator or filter mask where appropriate.
- Do not modify or alter or permit anyone else to modify or alter the equipment or any of its components in any way.
- Do not allow bystanders in the area when operating, attaching, removing, assembling, or servicing equipment.
- Use a suitable lifting device of sufficient capacity. Use adequate personnel to handle heavy components.
- Keep all persons away from operator control area while performing adjustments, service, or maintenance.

# LOADER MOUNT INSTALLATION

## WARNING

■ Only use this mounting kit for mounting Woods LUP126-2, LUP132-2 loaders on New Holland® T5040, T5050, T5060, T5070 2WD & FWA tractors and Case IH® Farmall® 85U, 95U and 105U 2WD & FWA tractors. Any other use or modification of this mounting kit may result in serious injury or death.

■ Safety instructions are important! Read all attachment and power unit manuals; follow all safety rules and safety decal information. (Replacement manuals and safety decals are available from your dealer. To locate your nearest dealer, check the Dealer Locator at [www.WoodsEquipment.com](http://www.WoodsEquipment.com), or in the United States and Canada call 1-800-319-6637.) Failure to follow instructions or safety rules can result in serious injury or death.

## CAUTION

■ Always wear relatively tight and belted clothing to avoid getting caught in moving parts. Wear sturdy, rough-soled work shoes and protective equipment for eyes, hair, hands, hearing, and head; and respirator or filter mask where appropriate.

## NOTICE

■ This equipment must be assembled and installed on the customer's tractor by the Woods dealer. Dealer must thoroughly inspect equipment and complete each item on the PRE-DELIVERY CHECK LIST, DELIVERY CHECK LIST, and PRODUCT REGISTRATION before equipment is released to the customer.

■ Clean threaded holes in the tractor chassis thoroughly using a tap of the proper size. Paint, rust, or debris in the threads may not permit cap screws to be installed and tightened correctly.

■ The Dealer must ensure that front tractor tires do not contact the loader or loader mounting brackets during operation. Tires must be checked for possible contact at full turning radius and maximum axle oscillation before operating the loader. See your tractor operator's manual for the proper adjustment procedure and adjust the front axle steering stops as required to obtain clearance.

### Tractor Preparation

For installing this mounting kit, references to right, left, forward, and rearward directions are determined from the operator's position in the tractor seat.

**NOTE:** OEM loader ready brackets are required to install this loader mount.

1. Shut off engine and set parking brake during installation.
2. Remove the tractor front weights and front weight bracket if equipped.
3. Loose hardware securing OEM loader ready brackets to tractor. This will help align mounting holes with Woods loader mounts.
4. Follow tractor operator manual instructions and adjust tires to the widest recommended setting to increase the tractor stability.

As a valued customer, Woods appreciates your comments. Once loader mount and hydraulic hoses have been installed, please take a few minutes to complete the Loader Mount Evaluation sheet that was supplied with this mount. Your comments will help us continue to bring you quality products.

## 4 Mount Installation

MAN0788 (1/16/2009)

## Install Right and Left Mid-Mounts

**NOTE:** Use an overhead lifting device capable of lifting mount. Slide strap through loader mounting hole and cinch (Figure 1). Mount should be balanced and hang straight.

1. Attach right mount to loader ready bracket using four cap screws (12) and hardened washers (10).
2. Attach right mount (3) to the tractor frame using four cap screws (12) and hardened flat washers (10).
3. Repeat steps to install left mount (4).

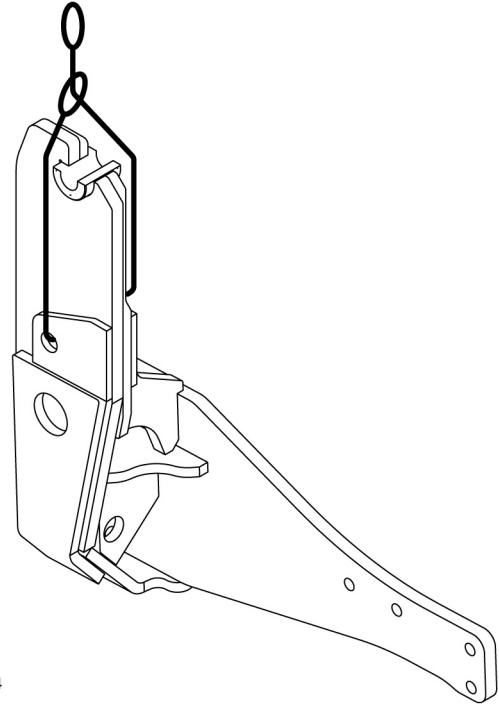
**NOTE:** On some tractor models the fuel tank is very close to the left loader ready bracket and may cause an interference point when cap screws (12) are installed. If interference is possible add a second washer (10) to each of the four cap screws.

4. Torque cap screws (12) to 374 lbs-ft (507 N-m). Check bolt size and torque loader ready bracket hardware to specifications listed on page 16.

3. 1028920 Right Mount
4. 1028921 Left mount
10. 1006371 3/4 Hardened flat washer, extra thk
12. 1030297 M20 x 2.5P x 65 mm HHCS CL10.9

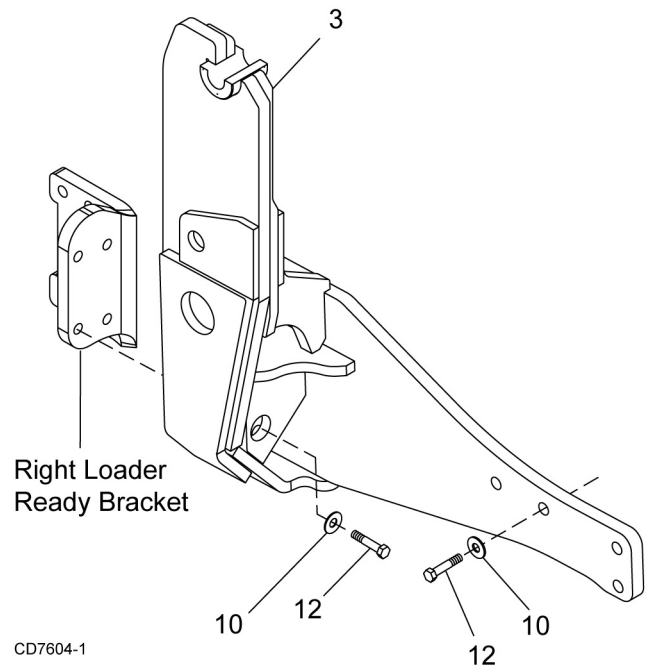


Figure 2. Right Mount Installed



CD7604-4

Figure 1. Lift Strap Location



CD7604-1

Figure 3. Right Mount Installation

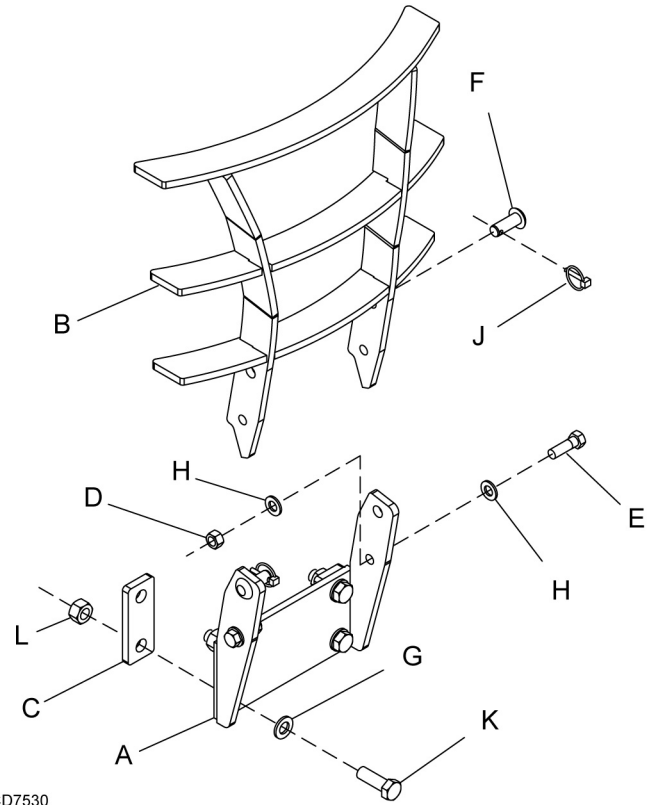
## Install Optional Grill Guard

1. Attach grill guard support bracket (A) to the front of the tractor using four cap screws (K), hardened flat washers (G), two spacers (C) and hex nuts (L)
2. Attach grill guard (B) to support bracket (A) using two (one per side) cap screw (E), four hardened flat washers (H) and hex nuts (D).

**NOTE:** Do not overtighten cap screws (E); grill guard must be able to pivot for access to the battery.

3. Rotate grill guard up and secure into position using two clevis pins (F) and lynch pins (J).
4. Torque cap screws (K) to 244 lbs-ft (330 N-m).

- A. 1028909 Grill guard support bracket
- B. 1028912 Grill guard
- C. 1028919 Grill guard spacer
- D. 230 5/8 NC Hex nut
- E. 902 5/8 NC x 2 HHCS GR5
- F. 26299 Clevis pin, 3/4 x 2
- G. 57798 3/4 Hardened flat washer
- H. 57817 5/8 Hardened flat washer
- J. 304075 Lynch pin, 1/4
- K. 307554 M20 x 2.5P x 60 HHCS
- L. 307913 M20 x 2.5P Hex nut



**Figure 4.** Grill Guard Installation

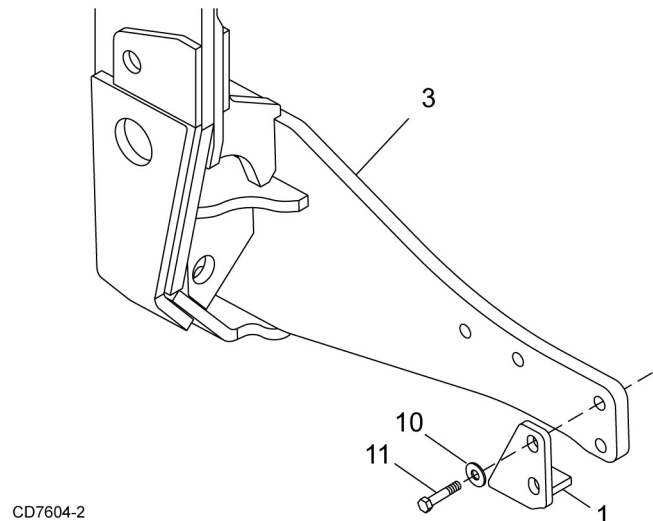
## Install Oscillation Stops (Optional)

Oscillation stops are not required on all tractors. To determine if stops are needed:

- Check tire clearance after loader has been installed.
- Raise front tires off the ground and oscillate front axle up and down, turning the tires in both directions.
- If tires contact loader or loader mount, oscillation stops will be required.

1. Remove the two from cap screws on loader mount. Place oscillation stop over mount and secure using two cap screws (11) and hardened flat washer previously removed.
2. Repeat steps to install oscillation stop on opposite side of tractor.
3. Torque cap screws (11) to 374 lbs-ft (507 N-m).

- 1. 1026397 Left oscillation stop
- 2. 1026398 Right oscillation stop



**Figure 5.** Right Oscillation Stop Installation

- 10. 1006371 3/4 Hardened flat washer, extra thk
- 11. 1028950 M20 x 2.5P x 80 mm HHCS CL10.9 (used with oscillation stops only)

# 6 Mount Installation

MAN0788 (1/16/2009)



# HOSE KIT INSTALLATION

## WARNING

- Keep hands and body away from pressurized lines. Use paper or cardboard, not hands or other body parts to check for leaks. Wear safety goggles. Hydraulic fluid under pressure can easily penetrate skin and will cause serious injury or death.
- Make sure that all operating and service personnel know that if hydraulic fluid penetrates skin, it must be surgically removed as soon as possible by a doctor familiar with this form of injury or gangrene, serious injury, or death will result. **CONTACT A PHYSICIAN IMMEDIATELY IF FLUID ENTERS SKIN OR EYES. DO NOT DELAY.**
- Air in hydraulic systems can cause erratic operation and allows loads or equipment components to drop unexpectedly. When connecting equipment or hoses or performing any hydraulic maintenance, purge any air in hydraulic system by operating all hydraulic functions several times. **Do this before putting into service or allowing anyone to approach the equipment.**

## WARNING

- Protective hose sleeves must cover all hydraulic hoses within 20 inches of the operator and be secured onto metal hose fittings. Replace hoses or sleeves if damaged or if protective sleeve cannot be properly positioned or secured.
- Make sure all hydraulic hoses, fittings, and valves are in good condition and not leaking before starting power unit or using equipment. Check and route hoses carefully to prevent damage. Hoses must not be twisted, bent sharply, kinked, frayed, pinched, or come into contact with any moving parts. Operate moveable components through full operational range to check clearances. Replace any damaged hoses immediately.

1028835 Hose Kit Installation-----Page 7

58025 Hose Kit Installation-----Page 10

## 1028835 HOSE KIT

### General Description

These instructions are for operating the LUP126-2 or LUP132-2 Loader using hose kit 1028835. To use one of these hydraulic connections, the tractor must be equipped with the manufacturer's multi-function control valve located under the right front corner of the operator's platform. Hoses will be connected between the loader and the hydraulic valve.

**NOTE:** Not all parts supplied with this hose kit are use for this application.



Figure 6. Tractor Hydraulic Control Valve Location

# 1028835 Hose Kit

## Install Fittings and Hoses

### Install Hydraulic Fitting, Control Valve

Install four adapters (4 or 5), elbows (8), colored bands (9-12), dust plugs (13) and female quick couplers (6) into the control valve located under the right tractor platform. See Figure 7.

**NOTE:** Check thread pitch of the tractor valve ports and choose the correct adapter (4 or 5).

### Install Loader Hoses

1. Attach male quick couplers (7) and colored bands (9-12) to each of the loader feedline hoses (3).
2. Attach loader feedline hoses (3) to the loader feedlines on the loader boom (Figure 8).

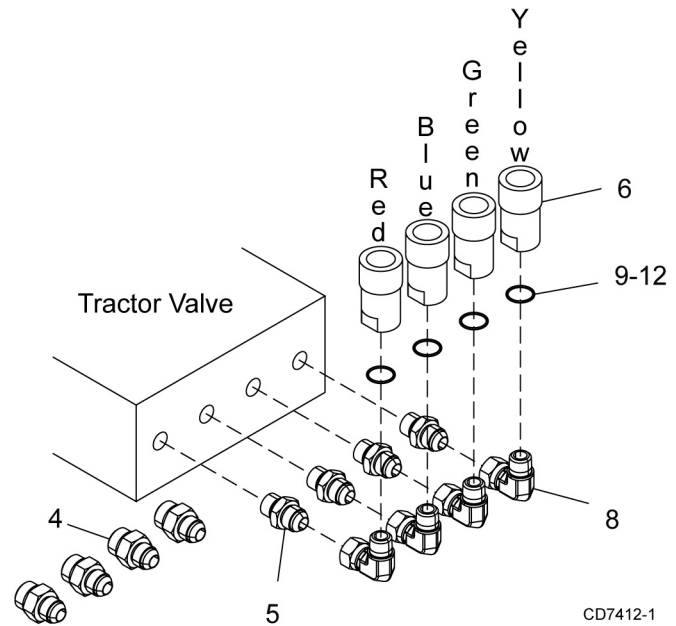
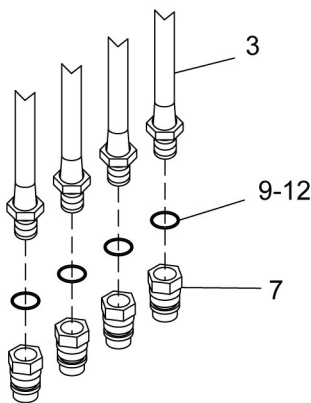


Figure 7. Hydraulic Fitting Installation

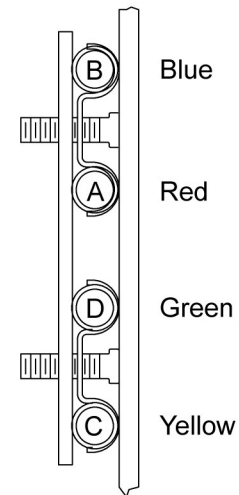
- |            |  |
|------------|--|
| 3. 1009513 | Hose, 76" x 3/8 NPTM x 3/4 JICM (1028835 Hose Kit) |
| 4. 1010920 | Adapter, M22 x 1.5M x 3/4 JICM                     |
| 5. 1012055 | Adapter, M18 x 1.5M x 3/4 JICM                     |
| 6. 64299   | Quick coupler, female 3/8                          |
| 7. 64300   | Quick coupler, male 3/8                            |

- |             |                                |
|-------------|--------------------------------|
| 8. 1026414  | Elbow, 3/8 NPTM x 3/4 JICF 90° |
| 9. 395061   | Plastic band, red              |
| 10. 395062  | Plastic band, blue             |
| 11. 56061   | Plastic band, green            |
| 12. 56062   | Plastic band, yellow           |
| 13. 1020232 | Dust plug, 3/8 (not shown)     |



Loader Feedline Hoses

- A - BUCKET CYL. BASE END (DUMP) - RED
- B - BUCKET CYL. ROD END (ROLLBACK) - BLUE
- C - BOOM CYL. ROD END (DOWN) - YELLOW
- D - BOOM CYL. BASE END (UP) - GREEN



LUP126-2 or LUP132-2 Loader Feedlines

Figure 8. Loader Feedline Connections

# 8 Hydraulic Installation

MAN0788 (1/16/2008)



## 1028835 Hose Kit

### Secure Hoses

Secure hoses to the back of right loader upright using plastic tie as shown in Figure 9.

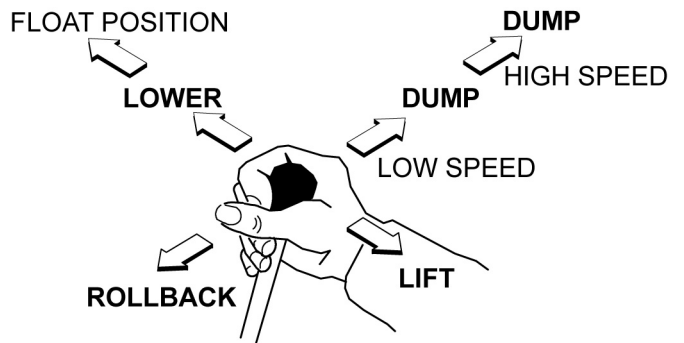
Do not cinch hoses tight, they need to move with the loader during operation.



Figure 9. Secure Hoses

### Verify Control Movements

- 1. Mount loader to tractor:** Remove mount pins from loader uprights. Align tractor with loader and slowly drive tractor into loader. Shut off tractor.
- Connect loader feedline hoses to tractor control valve couplers following color shown in Figure 8.
- Comply with all safety rules and start the tractor.
- Mount loader to tractor by activating bucket cylinders to raise or lower the loader uprights into the loader mounts. Slowly advance tractor forward, activating appropriate cylinders to engage loader completely into mounts. Insert mounting pins to secure loader.
- Check that all tractor hydraulic control lever positions operate the loader movements correctly. See Figure 10.
- If loader movements do not respond correctly, shut off tractor, relieve pressure, and reconnect properly. Loader control movements must be correct before proceeding.
- Once all loader functions are correct, start the tractor and operate the loader to check for leaks. Purge any remaining air from the hydraulic system and check oil level.
- When hose routings and correct loader operations are verified, identify each circuit by placing a matching colored band around the male and female quick-disconnect coupler. The color-coded bands will make reinstallation easier when the loader is removed from tractor.
- Attach the plastic tie straps (included in kit) every 20-inches around the hoses to keep them tightly bundled and away from contact with the ground or other moving parts on the tractor or loader.
- Before operating the loader, make sure that the Pre-Delivery, Delivery, and Pre-Operation Checklists in the Loader Operator's Manual have been completed.



- Handle forward - Boom down
- Handle forward to limit - Float position
- Handle back - Boom up
- Handle right -  
Dump bucket or attachment (slow)
- Handle right to limit -  
Dump bucket or attachment (fast)
- Handle to left - Rollback bucket or attachment

Figure 10. Single Lever Control Operation

# 58025 HOSE KIT

## General Description

These set-up instructions are for operating the LUP126-2 or LUP132-2 loader using the tractor hydraulic rear remote control couplers. To use this hydraulic connection, the tractor must be equipped with two hydraulic levers and four tractor hydraulic couplers shown in Figure 11.

**NOTE:** Hydraulic couplers for connection to tractor are NOT INCLUDED with this hose kit but are available as service parts.

Not all parts supplied in hose kit are used for this application.

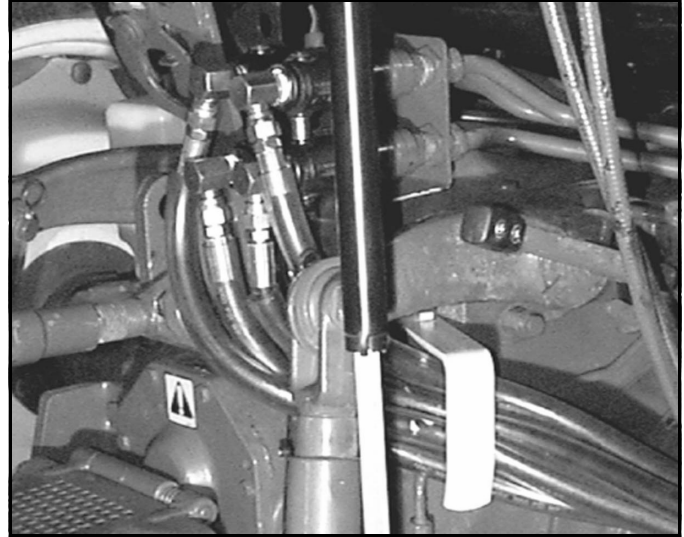


Figure 11. Tractor Hydraulic Couplers

## Connect and Route Hoses

1. Attach a 90-degree elbow (2) and male quick coupler (3) to each loader supply hose (1).
2. Connect loader supply hoses to loader feedlines as shown in Figure 12.
3. Route hydraulic hoses along loader mount, under the right side of operator's platform, and over the rear axle.

**NOTE:** Be sure to avoid contact with three-point linkage, brake pedals, and other moveable tractor components.

**NOTE:** Hoses must be routed so that they are not pinched, bent sharply, or chafed during operation. Hoses must not interfere with any tractor control operation or contact any moving parts.

1. 53670 Hose, 150" x 3/4 JICM x 3/4 JICM
2. 313053 Elbow, 3/4 JICF x 1/2 NPTM 90°
3. 66511 Quick coupler, male 1/2"  
(not supplied in kit)

## LUP126-2, LUP132-2 Loader Feedlines

- A - BUCKET CYL. BASE END (DUMP) - RED
- B - BUCKET CYL. ROD END (ROLLBACK) - BLUE
- C - BOOM CYL. ROD END (DOWN) - YELLOW
- D - BOOM CYL. BASE END (UP) - GREEN

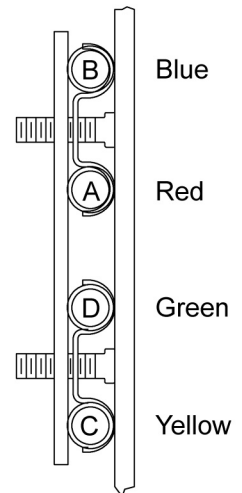


Figure 12. Loader Feedline Identification

## 58025 Hose Kit

### Install Hose Brackets

1. Remove right rear rockshaft housing cap screw and attach hose guide (5) as shown in Figure 13. Secure using tractor hardware.
2. Attach hose support (4) to right side of transmission housing using cap screw (6) and lock washer (7), Figure 14.
3. Tighten all cap screws to specifications given on the Bolt Torque Chart, Page 16.
4. Route hoses behind hose guide and connect hydraulic hoses to tractor hydraulic couplers as shown in Figure 13.

4. 54299 Hose support bracket
5. 54305 Hose guide bracket
6. 64084 M14 x 1.5P x 30 mm Cap screw
7. 855 1/2 Lock washer

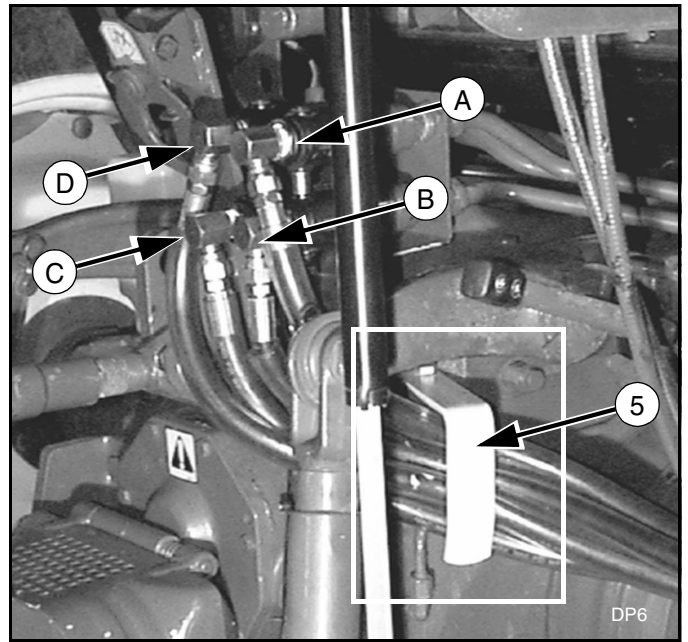


Figure 13. Hose Guide Installed

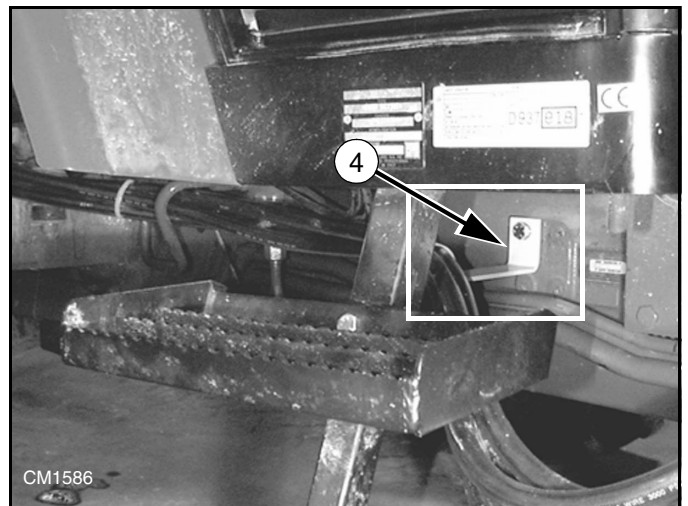


Figure 14. Hose Support Bracket

### Verification of Control Movements

1. **Mount loader to tractor:** Remove mount pins from loader uprights. Align tractor with loader and slowly drive tractor into loader. Shut off tractor.

2. Connect loader feedline hoses to tractor remote hydraulic couplers. See Figure 12.

**NOTE:** At least 6" spacing should be maintained between valve, bracket, or hoses and any tractor control (brake pedals, accelerator, hand throttle, or hydraulic levers).

3. Comply with all Safety Rules and start the tractor.

4. Mount loader to tractor by activating bucket cylinders to raise or lower the loader uprights into the loader mounts. Slowly advance tractor forward, activating appropriate cylinders to engage loader completely into mounts. Insert mounting pins to secure loader.

5. Check that all hydraulic control lever positions operate the loader movements correctly as shown in Figure 15.

6. If loader movements do not respond correctly, shut off tractor, relieve pressure, and reconnect properly. Loader control movements must be correct before proceeding.

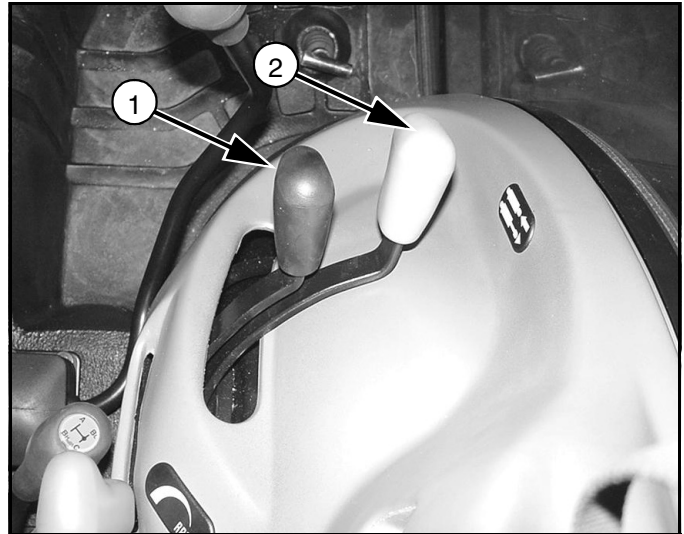
7. Once all loader functions are correct, start the tractor and operate the loader to check for leaks. Purge any remaining air from the hydraulic system.

8. When hose routings and correct loader operations are verified, identify each circuit by placing a matching colored band around the male and female quick-disconnect coupler set. The colored bands will make re-installation easier when the loader is removed from the tractor.

9. Be sure that adequate slack is left in the hoses so they can move as the loader moves through its full range of motion.

10. Attach plastic tie straps every 20" around the hoses to keep them tightly bound and away from contact with the ground or other moving parts on tractor.

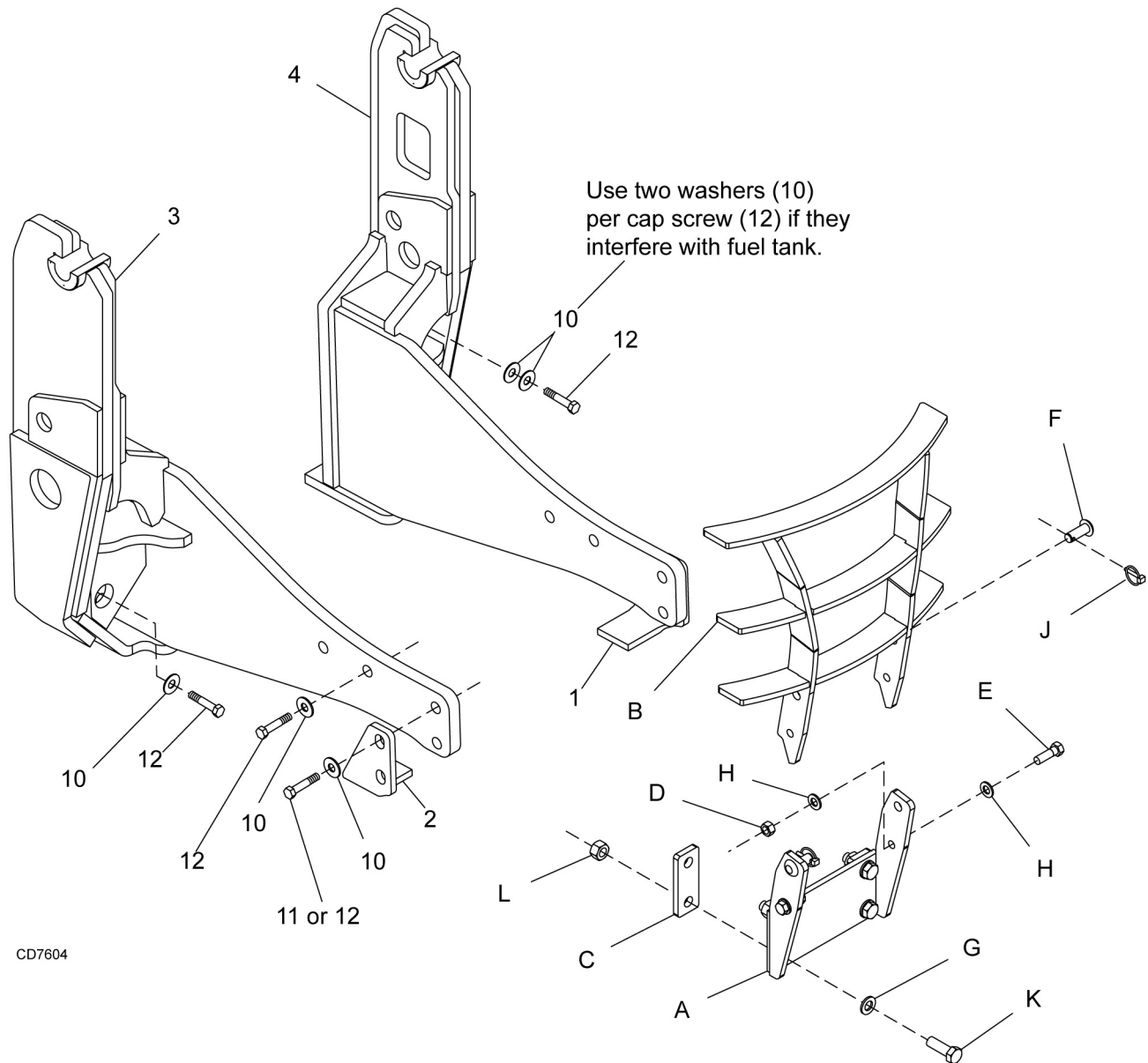
11. Before operating the loader, make sure that the Pre-Delivery, Delivery, and Pre-Operation Checklists in the Loader Operator's Manual have been completed.



- Control 1, Handle forward - Dump bucket or attachment
- Control 1, Handle back - Rollback bucket or attachment
- Control 2, Handle forward - Boom down
- Control 2, Handle back - Boom up

**Figure 15.** Tractor Control Operation (Typical)

# 2300012 LOADER MOUNTING KIT



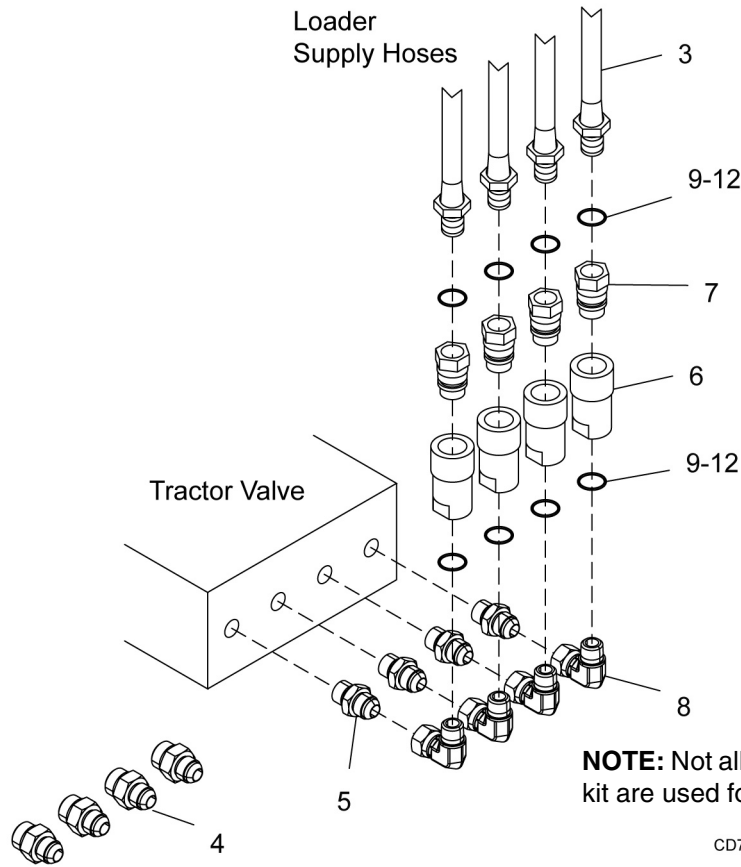
CD7604

REF	PART	QTY	DESCRIPTION
1	1026397	1	Left oscillation stop
2	1026398	1	Right oscillation stop
3	1028920	1	Right rear mount
4	1028921	1	Left rear mount
10	1006371	20	3/4 Hardened flat washer, extra thick
11	1028950	4	M20 x 2.5P x 80 mm HHCS CL10.9 (used with oscillation stops only)
12	1030297	16	M20 x 2.5P x 65 mm HHCS CL10.9
A	1028909	1	Grill guard support bracket
B	1028912	1	Grill guard

REF	PART	QTY	DESCRIPTION
C	1028919	2	Grill guard spacer
D	230 *	2	5/8 NC Hex nut
E	902 *	2	5/8 NC x 2 HHCS GR5
F	26299 *	2	Clevis pin, 3/4 x 2
G	57798	4	3/4 Hardened flat washer
H	57817	4	5/8 Hardened flat washer
J	304075 *	2	Lynch pin, 1/4
K	307554	4	M20 x 2.5P x 60 mm
L	307913	4	M20 x 2.5P Hex nut

\* Standard hardware, obtain locally

# 1028835 HOSE KIT



REF	PART	QTY	DESCRIPTION
3	1009513	4	Hose, 76" x 3/8 NPTM x 3/4 JICM
4	1010920	4	Adapter, M22 x 1.5M x 3/4 JICM
5	1012055	4	Adapter, M18 x 1.5M x 3/4 JICM
6	64299	4	Quick coupler, female 3/8 ISO B
7	64300	4	Quick coupler, male 3/8 ISO B
8	1026414	4	Elbow, 3/8 NPTM x 3/4 JICF

REF	PART	QTY	DESCRIPTION
9	395061	2	Plastic band, red
10	395062	2	Plastic band, blue
11	56061	2	Plastic band, green
12	56062	2	Plastic band, yellow
13	1020232	4	Dust plug, 3/8 ISO B (NS)
14	88 *		Plastic tie (NS)

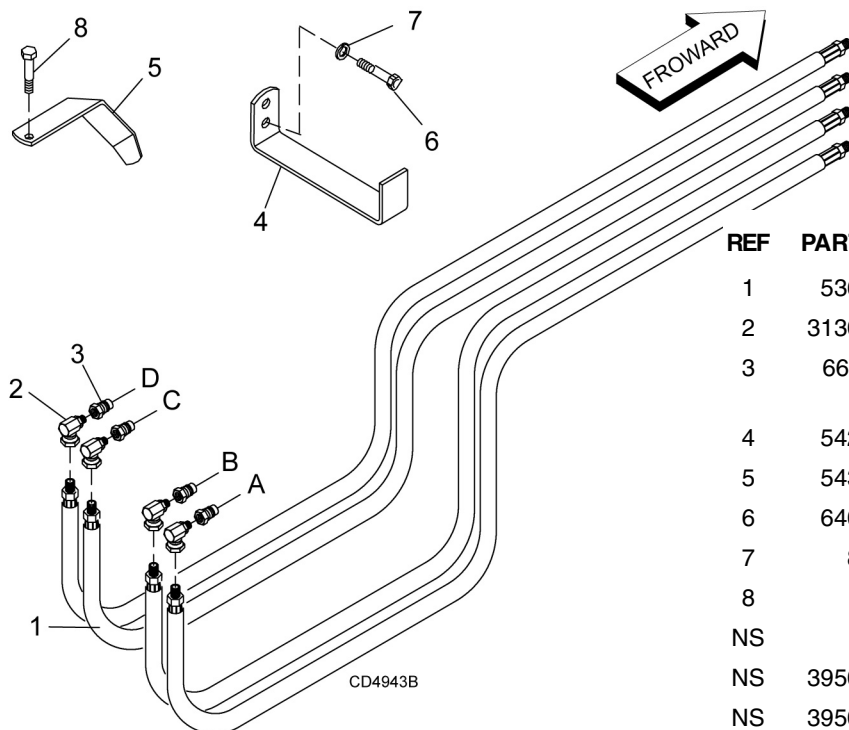
NS Not shown

\* Standard hardware, obtain locally

**14 Parts**

MAN0788 (1/16/2009)

# 58025 HOSE KIT



**NOTE:** Not all parts supplied with this hose kit are used for this application.

REF	PART	QTY	DESCRIPTION
1	53670	4	Hose 150" x 3/4 JICM x 3/4 JICM
2	313053	4	Elbow, 3/4 JICF x 1/2 NPTM 90°
3	66511	4	Quick coupler, male 1/2" (not included in kit)
4	54299	1	Hose support bracket
5	54305	1	Hose guide bracket
6	64084	1	M14 x 1.5P x 30 mm Cap screw
7	855 *	1	1/2 Lock washer
8		1	Tractor hardware
NS	88 *		Plastic tie
NS	395061	2	Plastic band, red
NS	395062	2	Plastic band, blue
NS	56061	2	Plastic band, green
NS	56062	2	Plastic band, yellow

NS Not shown

\* Standard hardware, obtain locally



# BOLT TORQUE CHART

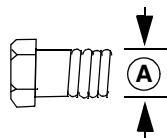
Always tighten hardware to these values unless a different torque value or tightening procedure is listed for a specific application.

Fasteners must always be replaced with the same grade as specified in the manual parts list.

Always use the proper tool for tightening hardware: SAE for SAE hardware and Metric for metric hardware.

Make sure fastener threads are clean and you start thread engagement properly.

All torque values are given to specifications used on hardware defined by SAE J1701 MAR 99 & J1701M JUL 96.



## SAE SERIES TORQUE CHART



SAE Grade 2  
(No Dashes)

SAE Bolt Head Identification

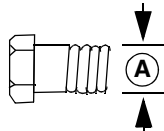


SAE Grade 5  
(3 Radial Dashes)



SAE Grade 8  
(6 Radial Dashes)

Ⓐ Diameter (Inches)	Wrench Size	MARKING ON HEAD					
		SAE 2		SAE 5		SAE 8	
		lbs-ft	N-m	lbs-ft	N-m	lbs-ft	N-m
1/4"	7/16"	6	8	10	13	14	18
5/16"	1/2"	12	17	19	26	27	37
3/8"	9/16"	23	31	35	47	49	67
7/16"	5/8"	36	48	55	75	78	106
1/2"	3/4"	55	75	85	115	120	163
9/16"	13/16"	78	106	121	164	171	232
5/8"	15/16"	110	149	170	230	240	325
3/4"	1-1/8"	192	261	297	403	420	569
7/8"	1-5/16"	306	416	474	642	669	907
1"	1-1/2"	467	634	722	979	1020	1383



## METRIC SERIES TORQUE CHART



Metric  
Grade 8.8

Metric Bolt Head Identification

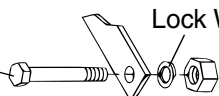


Metric  
Grade 10.9

Ⓐ Diameter & Thread Pitch (Millimeters)	Wrench Size	COARSE THREAD				FINE THREAD				Ⓐ Diameter & Thread Pitch (Millimeters)
		MARKING ON HEAD								
		Metric 8.8		Metric 10.9		Metric 8.8		Metric 10.9		
		N-m	lbs-ft	N-m	lbs-ft	N-m	lbs-ft	N-m	lbs-ft	
6 x 1.0	10 mm	8	6	11	8	8	6	11	8	6 x 1.0
8 x 1.25	13 mm	20	15	27	20	21	16	29	22	8 x 1.0
10 x 1.5	16 mm	39	29	54	40	41	30	57	42	10 x 1.25
12 x 1.75	18 mm	68	50	94	70	75	55	103	76	12 x 1.25
14 x 2.0	21 mm	109	80	151	111	118	87	163	120	14 x 1.5
16 x 2.0	24 mm	169	125	234	173	181	133	250	184	16 x 1.5
18 x 2.5	27 mm	234	172	323	239	263	194	363	268	18 x 1.5
20 x 2.5	30 mm	330	244	457	337	367	270	507	374	20 x 1.5
22 x 2.5	34 mm	451	332	623	460	495	365	684	505	22 x 1.5
24 x 3.0	36 mm	571	421	790	583	623	459	861	635	24 x 2.0
30 x 3.0	46 mm	1175	867	1626	1199	1258	928	1740	1283	30 x 2.0

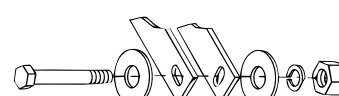
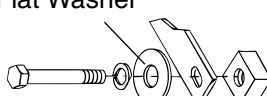
### Typical Washer Installations

Bolt



Lock Washer

Flat Washer



8/9/00

# BOLT SIZE CHART

**NOTE:** Chart shows bolt thread sizes and corresponding head (wrench) sizes for standard SAE and metric bolts.

## SAE Bolt Thread Sizes

5/16

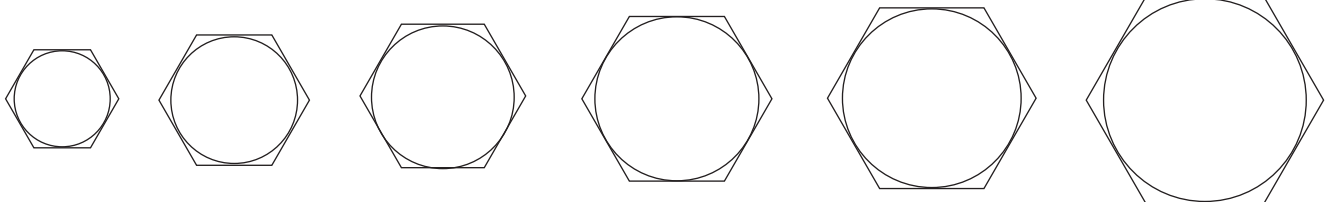
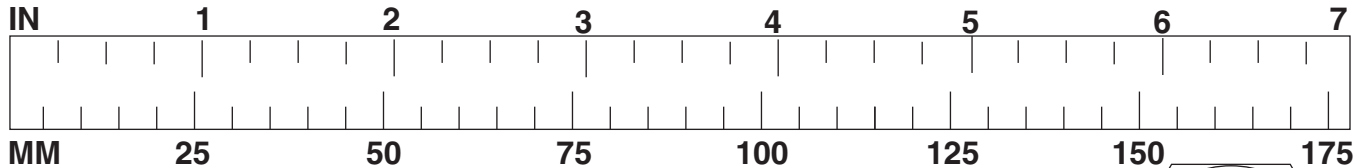
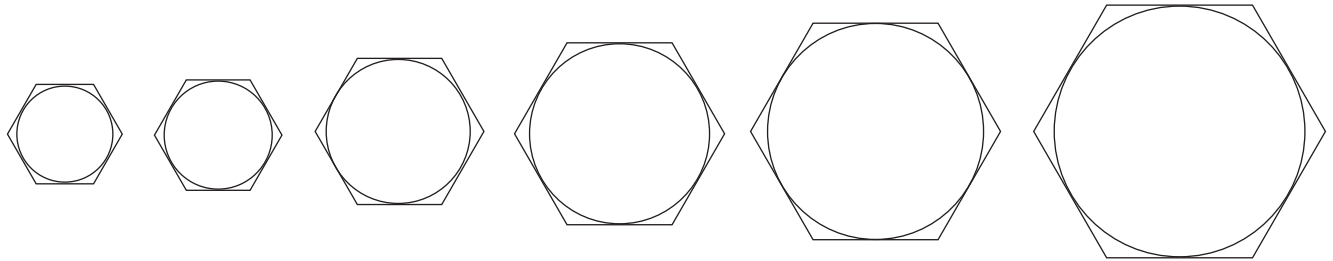
3/8

1/2

5/8

3/4

7/8



## Metric Bolt Thread Sizes

8MM

10MM

12MM

14MM

16MM

18MM

## ABBREVIATIONS

AG ..... Agriculture  
 ASABE..... American Society of Agricultural & Biological Engineers (formerly ASAE)  
 ASAE ..... American Society of Agricultural Engineers  
 ATF ..... Automatic Transmission Fluid  
 BSPP ..... British Standard Pipe Parallel  
 BSPTM ..... British Standard Pipe Tapered Male  
 CV ..... Constant Velocity  
 CCW ..... Counter-Clockwise  
 CW ..... Clockwise  
 F ..... Female  
 FT ..... Full Thread  
 GA ..... Gauge  
 GR (5, etc.) ..... Grade (5, etc.)  
 HHCS ..... Hex Head Cap Screw  
 HT ..... Heat-Treated  
 JIC ..... Joint Industry Council 37° Degree Flare  
 LH ..... Left Hand  
 LT ..... Left  
 m ..... Meter  
 mm ..... Millimeter  
 M ..... Male

MPa ..... Mega Pascal  
 N ..... Newton  
 NC ..... National Coarse  
 NF ..... National Fine  
 NPSM ..... National Pipe Straight Mechanical  
 NPT ..... National Pipe Tapered  
 NPT SWF ..... National Pipe Tapered Swivel Female  
 ORBM ..... O-Ring Boss - Male  
 P ..... Pitch  
 PBY ..... Power-Beyond  
 psi ..... Pounds per Square Inch  
 PTO ..... Power Take Off  
 QD ..... Quick Disconnect  
 RH ..... Right Hand  
 ROPS ..... Roll-Over Protective Structure  
 RPM ..... Revolutions Per Minute  
 RT ..... Right  
 SAE ..... Society of Automotive Engineers  
 UNC ..... Unified Coarse  
 UNF ..... Unified Fine  
 UNS ..... Unified Special



# WARRANTY

(All Models Except Mow'n Machine™ Zero-Turn Mowers and Woods Boundary™ Utility Vehicles)

Please Enter Information Below and Save for Future Reference.

Date Purchased: \_\_\_\_\_ From (Dealer): \_\_\_\_\_

Model Number: \_\_\_\_\_ Serial Number: \_\_\_\_\_

Woods Equipment Company ("WOODS") warrants this product to be free from defect in material and workmanship. Except as otherwise set forth below, the duration of this Warranty shall be for TWELVE (12) MONTHS COMMENCING ON THE DATE OF DELIVERY OF THE PRODUCT TO THE ORIGINAL PURCHASER.

Woods backhoe models BH70-X, BH80-X, and BH90-X are warranted for two (2) years from the date of delivery to the original purchaser.

The warranty periods for specific parts or conditions are listed below:

Part or Condition Warranted	Model Number	Duration (from date of delivery to the original purchaser)
Gearbox components	BW1260, BW1620, BW1800, BW2400	8 years
	BW240HD	7 years
	BB48X, BB60X, BB72X, BB84X, BB600X, BB720X, BB840X, BB6000X, BB7200X, BB8400X, DS1260, DSO1260, DS1440, TS1680, BW126-3, BW180-3, BW240	6 years
	PHD25, PHD35, PHD65, PHD95, 2162, 3240, DS96, DS120, RCC42, RM550-2, RM660-2, RM990-3, PRD6000, PRD7200, PRD8400, 7144RD-2, 9180RD-2, 9204RD-2, S15CD, S20CD, S22CD, S25CD, S27CD	5 years
	RDC54, RD60, RD72, TBW150C	3 years (1 year if used in rental or commercial applications)
Blade spindles	RM550-2, RM660-2, RM990-3, PRD6000, PRD7200, PRD8400, 7144RD-2, 9180RD-2, 9204RD-2	3 years
Rust-through	BB600, BB720, BB840, BB6000, BB7200, BB8400, BW126-3, BW180-3, BW1260, BW1800, BW240, BW240HD, 2162, 3240, DS1260, DSO1260, DS1440, TS1680	10 years

Under no circumstances will this Warranty apply in the event that the product, in the good faith opinion of WOODS, has been subjected to improper operation, improper maintenance, misuse, or an accident. This Warranty does not apply in the event that the product has been materially modified or repaired by someone other than WOODS, a WOODS authorized dealer or distributor, and/or a WOODS authorized service center. This Warranty does not cover normal wear or tear, or normal maintenance items. This Warranty also does not cover repairs made with parts other than those obtainable through WOODS.

This Warranty is extended solely to the original purchaser of the product. Should the original purchaser sell or otherwise transfer this product to a third party, this Warranty does not transfer to the third party purchaser in any way. There are no third party beneficiaries of this Warranty.

WOODS makes no warranty, express or implied, with respect to engines, batteries, tires or other parts or accessories not manufactured by WOODS. Warranties for these items, if any, are provided separately by their respective manufacturers.

WOODS' obligation under this Warranty is limited to, at WOODS' option, the repair or replacement, free of charge, of the product if WOODS, in its sole discretion, deems it to be defective or in noncompliance with this Warranty. **The product must be returned to WOODS with proof of purchase within thirty (30) days after such defect or noncompliance is discovered or should have been discovered, routed through the dealer and distributor from whom the purchase was made, transportation charges prepaid.** WOODS shall complete such repair or replacement within a reasonable time after WOODS receives the product. **THERE ARE NO OTHER REMEDIES UNDER THIS WARRANTY. THE REMEDY OF REPAIR OR REPLACEMENT IS THE SOLE AND EXCLUSIVE REMEDY UNDER THIS WARRANTY.**

THERE ARE NO WARRANTIES WHICH EXTEND BEYOND THE DESCRIPTION ON THE FACE OF THIS WARRANTY. WOODS MAKES NO OTHER WARRANTY, EXPRESS OR IMPLIED, AND WOODS SPECIFICALLY DISCLAIMS ANY IMPLIED WARRANTY OF MERCHANTABILITY AND/OR ANY IMPLIED WARRANTY OF FITNESS FOR A PARTICULAR PURPOSE.

**WOODS shall not be liable for any incidental or consequential losses, damages or expenses, arising directly or indirectly from the product, whether such claim is based upon breach of contract, breach of warranty, negligence, strict liability in tort or any other legal theory.** Without limiting the generality of the foregoing, Woods specifically disclaims any damages relating to (i) lost profits, business, revenues or goodwill; (ii) loss of crops; (iii) loss because of delay in harvesting; (iv) any expense or loss incurred for labor, supplies, substitute machinery or rental; or (v) any other type of damage to property or economic loss.

This Warranty is subject to any existing conditions of supply which may directly affect WOODS' ability to obtain materials or manufacture replacement parts.

No agent, representative, dealer, distributor, serviceperson, salesperson, or employee of any company, including without limitation, WOODS, its authorized dealers, distributors, and service centers, is authorized to alter, modify, or enlarge this Warranty.

Answers to any questions regarding warranty service and locations may be obtained by contacting:

**Woods Equipment Company**  
 2606 South Illinois Route 2  
 Post Office Box 1000  
 Oregon, Illinois 61061 USA  
 800-319-6637 tel  
 800-399-6637 fax  
 www.WoodsEquipment.com



**ALITEC™**  
**BMP®**  
**CENTRAL FABRICATORS®**  
**GANNON®**  
**GILL®**  
**WAIN-ROY®**  
**WOODS®**



## WARRANTY

(Replacement Parts For All Models Except Mow'n Machine™  
Zero-Turn Mowers and Woods Boundary™ Utility Vehicles)

Woods Equipment Company ("WOODS") warrants this product to be free from defect in material and workmanship for a period of ninety (90) days from the date of delivery of the product to the original purchaser with the exception of V-belts, which will be free of defect in material and workmanship for a period of 12 months.

Under no circumstances will this Warranty apply in the event that the product, in the good faith opinion of WOODS, has been subjected to improper operation, improper maintenance, misuse, or an accident. This Warranty does not cover normal wear or tear, or normal maintenance items.

This Warranty is extended solely to the original purchaser of the product. Should the original purchaser sell or otherwise transfer this product to a third party, this Warranty does not transfer to the third party purchaser in any way. There are no third party beneficiaries of this Warranty.

WOODS' obligation under this Warranty is limited to, at WOODS' option, the repair or replacement, free of charge, of the product if WOODS, in its sole discretion, deems it to be defective or in noncompliance with this Warranty. **The product must be returned to WOODS with proof of purchase within thirty (30) days after such defect or noncompliance is discovered or should have been discovered, routed through the dealer and distributor from whom the purchase was made, transportation charges prepaid.** WOODS shall complete such repair or replacement within a reasonable time after WOODS receives the product. THERE ARE NO OTHER REMEDIES UNDER THIS WARRANTY. THE REMEDY OF REPAIR OR REPLACEMENT IS THE SOLE AND EXCLUSIVE REMEDY UNDER THIS WARRANTY.

THERE ARE NO WARRANTIES WHICH EXTEND BEYOND THE DESCRIPTION ON THE FACE OF THIS WARRANTY. WOODS MAKES NO OTHER WARRANTY, EXPRESS OR IMPLIED, AND WOODS SPECIFICALLY DISCLAIMS ANY IMPLIED WARRANTY OF MERCHANTABILITY AND/OR ANY IMPLIED WARRANTY OF FITNESS FOR A PARTICULAR PURPOSE.

**WOODS shall not be liable for any incidental or consequential losses, damages or expenses, arising directly or indirectly from the product, whether such claim is based upon breach of contract, breach of warranty, negligence, strict liability in tort or any other legal theory.** Without limiting the generality of the foregoing, Woods specifically disclaims any damages relating to (i) lost profits, business, revenues or goodwill; (ii) loss of crops; (iii) loss because of delay in harvesting; (iv) any expense or loss incurred for labor, supplies, substitute machinery or rental; or (v) any other type of damage to property or economic loss.

This Warranty is subject to any existing conditions of supply which may directly affect WOODS' ability to obtain materials or manufacture replacement parts.

No agent, representative, dealer, distributor, service person, salesperson, or employee of any company, including without limitation, WOODS, its authorized dealers, distributors, and service centers, is authorized to alter, modify, or enlarge this Warranty.

Answers to any questions regarding warranty service and locations may be obtained by contacting:

### Woods Equipment Company

2606 South Illinois Route 2  
Post Office Box 1000  
Oregon IL 61061

800-319-6637 tel  
800-399-6637 fax  
[www.WoodsEquipment.com](http://www.WoodsEquipment.com)

# WOODS®

**ALITEC™**  
**BMP®**  
**CENTRAL FABRICATORS®**  
**GANNON®**  
**GILL®**  
**WAIN-ROY®**  
**WOODS®**

**Woods Equipment  
Company**

2606 South Illinois Route 2  
Post Office Box 1000  
Oregon, Illinois 61061 USA

800-319-6637 tel  
800-399-6637 fax  
[www.WoodsEquipment.com](http://www.WoodsEquipment.com)



©2009 Woods Equipment Company. All rights reserved. WOODS and the Woods logo are trademarks of Woods Equipment Company. All other trademarks, trade names, or service marks not owned by Woods Equipment Company that appear in this manual are the property of their respective companies or mark holders. Specifications subject to change without notice.

## Free Manuals Download Website

<http://myh66.com>

<http://usermanuals.us>

<http://www.somanuals.com>

<http://www.4manuals.cc>

<http://www.manual-lib.com>

<http://www.404manual.com>

<http://www.luxmanual.com>

<http://aubethermostatmanual.com>

Golf course search by state

<http://golfingnear.com>

Email search by domain

<http://emailbydomain.com>

Auto manuals search

<http://auto.somanuals.com>

TV manuals search

<http://tv.somanuals.com>