

WOODS REAR BLADE & LANDSCAPE RAKE

RBC60
LRC60

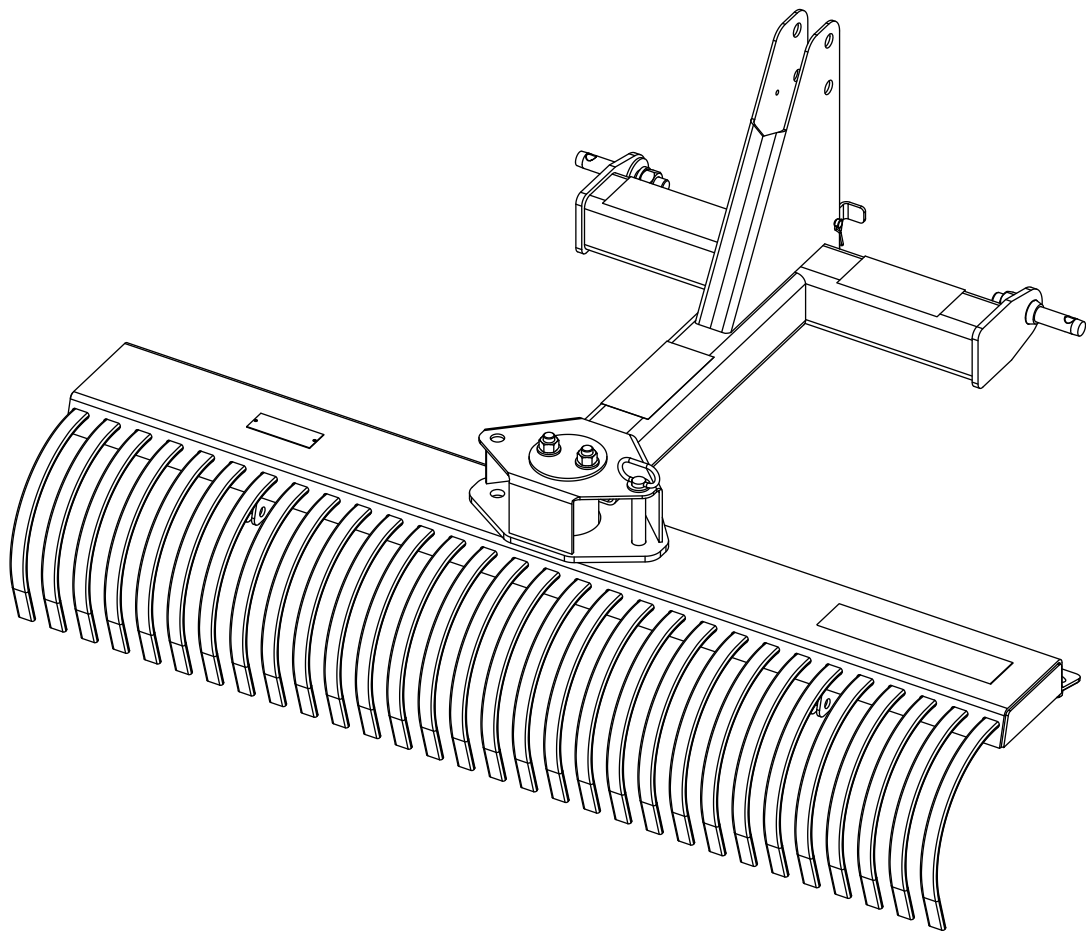

MAN0169

Rev. 3/09/2010

WOODS[®]
Tested. Proven. Unbeatable.

OPERATOR'S MANUAL

TO THE DEALER:

Assembly and proper installation of this product is the responsibility of the Woods® dealer. Read manual instructions and safety rules. Make sure all items on the Dealer's Pre-Delivery and Delivery Check Lists in the Operator's Manual are completed before releasing equipment to the owner.

The dealer must complete the online Product Registration form at the Woods Dealer Website which certifies that all Dealer Check List items have been completed. Please contact your dealer to complete this form. Dealers can register all Woods product at dealer.WoodsEquipment.com under Product Registration.

Failure to register the product does not diminish customer's warranty rights.

TO THE OWNER:

Read this manual before operating your Woods equipment. The information presented will prepare you to do a better and safer job. Keep this manual handy for ready reference. Require all operators to read this manual carefully and become acquainted with all adjustment and operating procedures before attempting to operate. Replacement manuals can be obtained from your dealer. To locate your nearest dealer, check the Dealer Locator at www.WoodsEquipment.com, or in the United States and Canada call 1-800-319-6637.

The equipment you have purchased has been carefully engineered and manufactured to provide dependable and satisfactory use. Like all mechanical products, it will require cleaning and upkeep. Lubricate the unit as specified. Observe all safety information in this manual and safety decals on the equipment.

For service, your authorized Woods dealer has trained mechanics, genuine Woods service parts, and the necessary tools and equipment to handle all your needs.

Use only genuine Woods service parts. Substitute parts will void the warranty and may not meet standards required for safe and satisfactory operation. Record the model number and serial number of your equipment in the spaces provided:

Model: _____ **Date of Purchase:** _____

Serial Number: (see Safety Decal section for location) _____

Provide this information to your dealer to obtain correct repair parts.

Throughout this manual, the term **NOTICE** is used to indicate that failure to observe can cause damage to equipment. The terms **CAUTION**, **WARNING**, and **DANGER** are used in conjunction with the Safety-Alert Symbol (a triangle with an exclamation mark) to indicate the degree of hazard for items of personal safety.



This is the safety alert symbol. It is used to alert you to potential personal injury hazards. Obey all safety messages that follow this symbol to avoid possible injury or death.



Indicates a hazardous situation which, if not avoided, will result in death or serious injury.



Indicates a hazardous situation which, if not avoided, could result in death or serious injury.



Indicates a hazardous situation which, if not avoided, could result in minor or moderate injury.

**IMPORTANT
or NOTICE**

Is used to address practices not related to personal injury.

NOTE

Indicates helpful information.

WOODS®

ALITEC™
BMP®
CENTRAL FABRICATORS®
GANNON®
GILL®
WAIN-ROY®
WOODS®

2 Introduction

Gen'l (Rev. 3/5/2010)

TABLE OF CONTENTS

INTRODUCTION	INSIDE FRONT COVER
SPECIFICATIONS	4
GENERAL INFORMATION	4
SAFETY RULES	5
SAFETY DECALS	7
OPERATION	9
MAINTENANCE	13
ASSEMBLY	15
DEALER CHECK LISTS	19
PARTS	
ASSEMBLY	20
MANUAL STORAGE TUBE KIT (OPTIONAL)	21
SKID SHOE AND TAIL WHEEL (OPTIONAL)	22
CATEGORY 1 QUICK HITCH BUSHING KIT (OPTIONAL)	22
CATEGORY 0 / 1 HITCH PIN KIT (OPTIONAL)	23
BOLT TORQUE CHART	24
BOLT SIZE CHART & ABBREVIATIONS	25
PRODUCT WARRANTY	24
REPLACEMENT PARTS WARRANTY	INSIDE BACK COVER

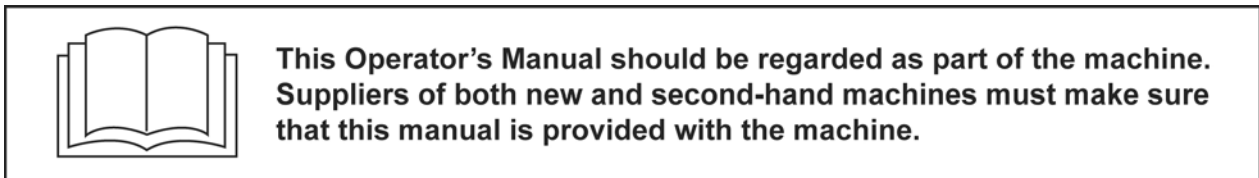
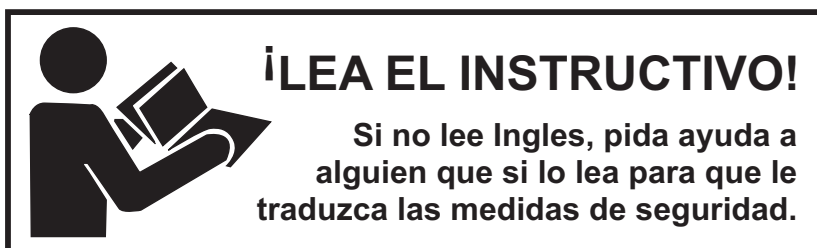

SPECIFICATIONS

	RBC60	LRC60
Overall Width	60 inches	60 inches
Weight	182 lbs.	177 lbs.
Moldboard Thickness	7-gauge	-----
Cutting Edge	1/2" x 6" x 60" Reversible	-----
Teeth	-----	30 - 5/16" x 1" HT High Carbon Tines
Position	360° Pivot	360° Pivot
Offset - Left or Right	12 inches	-----
Angle - Left or Right	15° or 30°	15° or 30°
Pitch Adjustment	Controlled by top link	Controlled by top link
Tractor Rating	Max. Engine 25 hp	Max. Engine 25 hp
Tractor 3-Point	Cat 0 or 1	Cat 0 or 1
Options	Skid Shoe & Cat 1 Quick Hitch Bushing Kit	Gauge Wheels & Cat 1 Quick Hitch Bushing Kit
Quick Hitch	Cat 1	Cat 1
Parking Stand	Included	Included

GENERAL INFORMATION

The purpose of this manual is to assist you in operating and maintaining your equipment. Read it carefully. It furnishes information and instructions that will help you achieve years of dependable performance.

These instructions have been compiled from extensive field experience and engineering data. Some information may be general in nature, due to unknown and varying operating conditions. However, through experience and these instructions, you should be able to develop procedures suitable to your particular situation.

The illustrations and data used in this manual were current at the time of printing. However, due to possible inline production changes, your machine may vary slightly in detail. We reserve the right to redesign and change the machines as may be necessary without notification.

Throughout this manual, references are made to right and left directions. These are determined by standing behind the tractor facing the direction of forward travel.

SAFETY RULES



ATTENTION! BECOME ALERT! YOUR SAFETY IS INVOLVED!



Safety is a primary concern in the design and manufacture of our products. Unfortunately, our efforts to provide safe equipment can be wiped out by an operator's single careless act.

In addition to the design and configuration of equipment, hazard control and accident prevention are dependent upon the awareness, concern, judgement, and proper training of personnel involved in the operation, transport, maintenance and storage of equipment.

It has been said "The best safety device is an informed, careful operator." We ask you to be that kind of operator.

TRAINING

- **Safety instructions are important! Read all attachment and power unit manuals; follow all safety rules and safety decal information. (Replacement manuals and safety decals are available from your dealer. To locate your nearest dealer, check the Dealer Locator at www.WoodsEquipment.com, or in the United States and Canada call 1-800-319-6637.) Failure to follow instructions or safety rules can result in serious injury or death.**
- **If you do not understand any part of this manual and need assistance, see your dealer.**
- **Know your controls and how to shut down quickly in an emergency.**
- **Operators must be instructed in and be capable of the safe operation of the equipment, its attachments, and all controls. Do not allow anyone to operate this equipment without proper instructions.**
- **Never allow children or untrained persons to operate equipment.**

PREPARATION

- **Check that all hardware is properly installed. Always tighten to torque chart specifications unless instructed otherwise in this manual.**
- **Always wear relatively tight and belted clothing to avoid entanglement in moving parts. Wear sturdy, rough-soled work shoes and protective equipment for eyes, hair, hands, hearing, and head; and respirator or filter mask where appropriate.**
- **Make sure attachment is properly secured, adjusted, and in good operating condition.**
- **Power unit must be equipped with ROPS or ROPS cab and seat belt. Keep seat belt securely**

fastened. Falling off power unit can result in death from being run over or crushed. Keep foldable ROPS systems in "locked up" position at all times.

- **Make sure all safety decals are installed. Replace if damaged. (See Safety Decals section for location.)**
- **A minimum 20% of tractor and equipment weight must be on the tractor front wheels when attachments are in transport position. Without this weight, front tractor wheels could raise up resulting in loss of steering. The weight may be attained with front wheel weights, ballast in tires or front tractor weights. Weigh the tractor and equipment. Do not estimate.**

OPERATION

- **Consult local utilities before working. Know location of all underground cables, pipelines, overhead wires, and other hazards in working area and avoid contact.**
- **Keep bystanders away from equipment.**
- **Do not operate or transport equipment while under the influence of alcohol or drugs.**
- **Operate only in daylight or good artificial light.**
- **Keep hands, feet, hair, and clothing away from equipment while engine is running. Stay clear of all moving parts.**
- **Always comply with all state and local lighting and marking requirements.**
- **Before transporting, pivot the unit so red reflectors face the rear.**
- **Never allow riders on power unit or attachment.**
- **Power unit must be equipped with ROPS or ROPS cab and seat belt. Keep seat belt securely fastened. Falling off power unit can result in death from being run over or crushed. Keep foldable ROPS systems in "locked up" position at all times.**
- **Always sit in power unit seat when operating controls or starting engine. Securely fasten seat belt, place transmission in neutral, engage brake, and ensure all other controls are disengaged before starting power unit engine.**
- **Look down and to the rear and make sure area is clear before operating in reverse.**
- **Do not operate or transport on steep slopes.**

(Safety Rules continued on next page)

SAFETY RULES



ATTENTION! BECOME ALERT! YOUR SAFETY IS INVOLVED!



(Safety Rules continued from previous page)

- Do not stop, start, or change directions suddenly on slopes.
- Use extreme care and reduce ground speed on slopes and rough terrain.
- Watch for hidden hazards on the terrain during operation.
- Stop power unit and equipment immediately upon striking an obstruction. Turn off engine, remove key, inspect, and repair any damage before resuming operation.
- Before changing positions of manual swing, tilt, or angle positions:
 - Park tractor on level ground, apply parking brake, level implement boom, shut off tractor, and remove key.
 - Make manual changes slowly and carefully to prevent hazardous movement of mechanisms.
 - Never stand in positions where you could become entrapped during adjustment changes or if the 3-point hitch suddenly lowers.
- Always secure lock pins with safety pins to prevent lock pins from bumping out of the positioning holes. Failure to do so may result in accidents and/or damage to blade.
- Before dismounting power unit or performing any service or maintenance, follow these steps: disengage power to equipment, lower the 3-point hitch and all raised components to the ground, operate valve levers to release any hydraulic pressure, set parking brake, stop engine, remove key, and unfasten seat belt.
- NEVER GO UNDERNEATH EQUIPMENT. Never place any part of the body underneath equipment or between moveable parts even when the engine has been turned off. Hydraulic system leak down, hydraulic system failures, mechanical failures, or movement of control levers can cause equipment to drop or rotate unexpectedly and cause severe injury or death.
 - Service work does not require going underneath.
 - Read Operator's Manual for service instructions or have service performed by a qualified dealer.

MAINTENANCE

- Before dismounting power unit or performing any service or maintenance, follow these steps: disengage power to equipment, lower the 3-point hitch and all raised components to the ground, operate valve levers to release any hydraulic pressure, set parking brake, stop engine, remove key, and unfasten seat belt.
- NEVER GO UNDERNEATH EQUIPMENT. Never place any part of the body underneath equipment or between moveable parts even when the engine has been turned off. Hydraulic system leak down, hydraulic system failures, mechanical failures, or movement of control levers can cause equipment to drop or rotate unexpectedly and cause severe injury or death.
 - Service work does not require going underneath.
 - Read Operator's Manual for service instructions or have service performed by a qualified dealer.
- Always wear relatively tight and belted clothing to avoid entanglement in moving parts. Wear sturdy, rough-soled work shoes and protective equipment for eyes, hair, hands, hearing, and head; and respirator or filter mask where appropriate.
- Make sure attachment is properly secured, adjusted, and in good operating condition.
- Keep all persons away from operator control area while performing adjustments, service, or maintenance.
- Tighten all bolts, nuts and screws to torque chart specifications. Check that all cotter pins are installed securely to ensure equipment is in a safe condition before putting unit into service.
- Make sure all safety decals are installed. Replace if damaged. (See Safety Decals section for location.)

STORAGE

- Block equipment securely for storage.
- Keep children and bystanders away from storage area.
- Follow manual instructions for storage.



SAFETY & INSTRUCTIONAL DECALS

ATTENTION! BECOME ALERT! YOUR SAFETY IS INVOLVED!

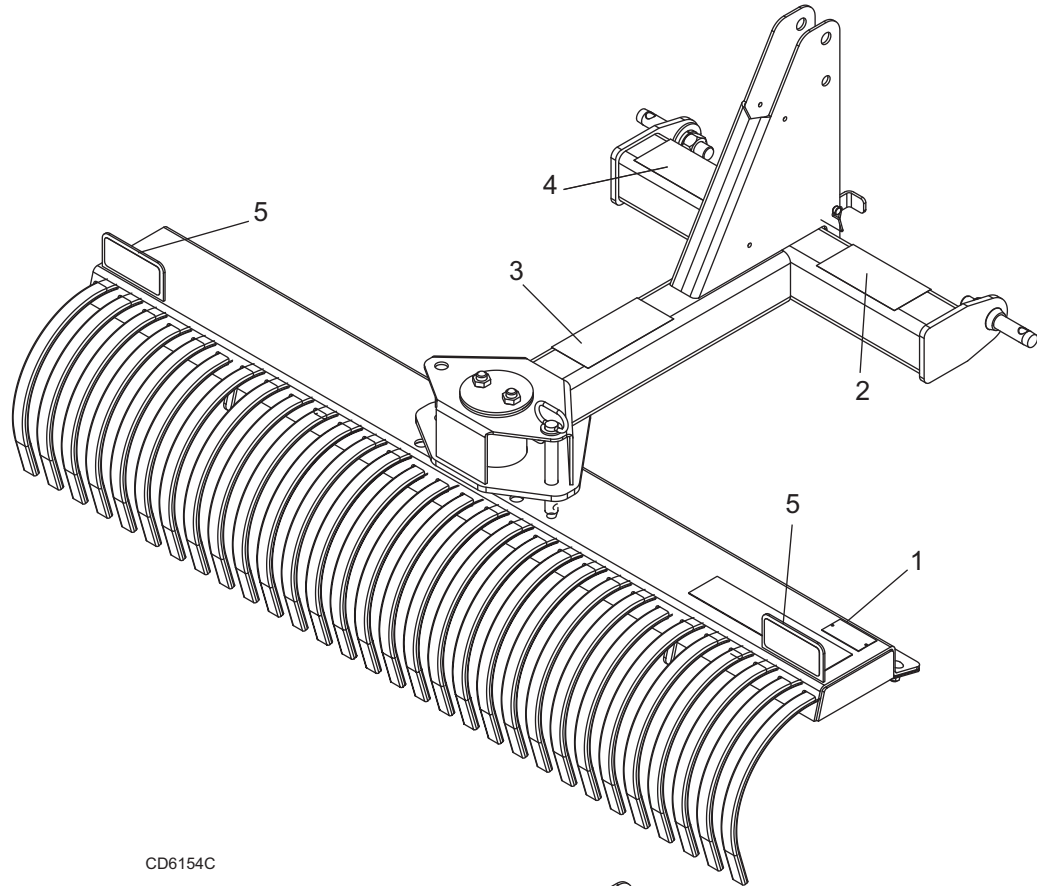

CD6154C

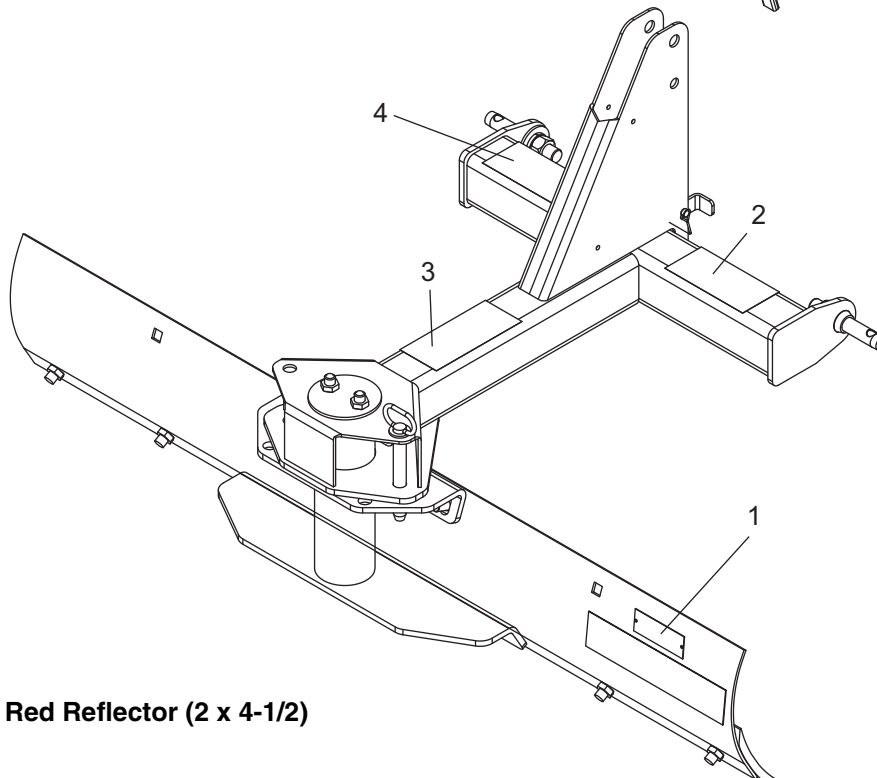

5 - 20106 Red Reflector (2 x 4-1/2)



SAFETY & INSTRUCTIONAL DECALS

ATTENTION! BECOME ALERT! YOUR SAFETY IS INVOLVED!



Replace Immediately If Damaged!

1 - Serial Number Plate

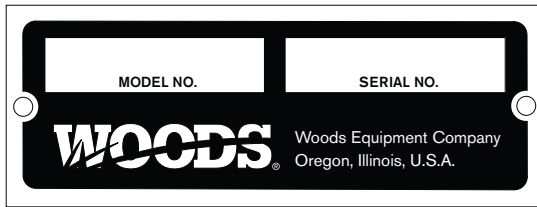

4 - 1004299

WARNING

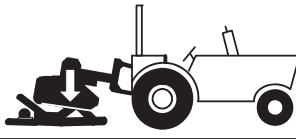
FALLING OFF CAN RESULT IN BEING RUN OVER.

- Tractor must be equipped with ROPS (or ROPS CAB) and seat belt. Keep foldable ROPS systems in "locked up" position at all times.
- Buckle Up! Keep seat belt securely fastened.
- Allow no riders.

RAISED IMPLEMENT CAN DROP AND CRUSH.

- Never go underneath raised implement which can drop from equipment or tractor 3-point hitch hydraulic leak down, hydraulic system failures, movement of control levers, or mechanical linkage failures.
- Service work does not require going underneath implement. Read manual instructions.

FALLING OFF OR GOING UNDERNEATH IMPLEMENT CAN RESULT IN SERIOUS INJURY OR DEATH.

1004299

2 - 1004250

WARNING

TO AVOID SERIOUS INJURY OR DEATH:

- Read Operator's Manual before operating, servicing, or repairing equipment. Follow all safety rules and instructions. (Manuals are available from dealer or call 1-800-319-6637.)
- Operate from tractor seat only.
- Lower equipment to ground, stop engine, remove key, and set brake before dismounting tractor.
- Never allow children or untrained persons to operate equipment.
- Never allow riders.
- Keep bystanders away from equipment during operation.
- Keep all shields in place and in good condition.

FAILURE TO FOLLOW THESE INSTRUCTIONS CAN RESULT IN INJURY OR DEATH.

1004250

3 - 1002941

WARNING



CRUSHING AND PINCHING HAZARD

- Be extremely careful handling various parts of the machine. They are heavy and hands, fingers, feet, and other body parts could be crushed or pinched between tractor and implement.
- Operate tractor controls from tractor seat only.
- Do not stand between tractor and implement when tractor is in gear.
- Make sure parking brake is engaged before going between tractor and implement.
- Stand clear of machine while in operation or when it is being raised or lowered.

FAILURE TO FOLLOW THESE INSTRUCTIONS COULD RESULT IN SERIOUS INJURY OR DEATH.

1002941-A

BE CAREFUL!

Use a clean, damp cloth to clean safety decals.

Avoid spraying too close to decals when using a pressure washer; high-pressure water can enter through very small scratches or under edges of decals causing them to peel or come off.

Replacement safety decals can be ordered free from your Woods dealer. To locate your nearest dealer, check the Dealer Locator at www.WoodsEquipment.com, or in the United States and Canada call 1-800-319-6637.

OPERATION

The operator is responsible for the safe operation of this equipment. Operators must be instructed in and be capable of the safe operation of the equipment, its attachments and all controls. Do not allow anyone to operate this equipment without proper instructions.

This equipment is designed for a wide range of applications. The blade may be used for scraping, leveling, grading and backfilling. The rake may be used for loosening, leveling and clearing soil of debris.

The blade or rake may be angled to windrow debris to the side for removal.

WARNING

- Never allow children or untrained persons to operate equipment.
- Keep bystanders away from equipment.
- Never allow riders on power unit or attachment.
- A minimum 20% of tractor and equipment weight must be on the tractor front wheels when attachments are in transport position. Without this weight, tractor could tip over, causing personal injury or death. The weight may be attained with a loader, front wheel weights, ballast in tires or front tractor weights. Weigh the tractor and equipment. Do not estimate.

CAUTION

- Always wear relatively tight and belted clothing to avoid entanglement in moving parts. Wear sturdy, rough-soled work shoes and protective equipment for eyes, hair, hands, hearing, and head; and respirator or filter mask where appropriate.

CONNECT REAR BLADE OR RAKE TO TRACTOR

1. This rake or blade should be mounted on tractors with a maximum drawbar rating of 25 engine hp, not to exceed 2000 lbs.
2. Adjust or remove tractor drawbar to eliminate interference with blade or rake.

Category 1

1. Place tractor 3-point lower lift arms over outer hitch pins.
2. Secure with klik pin (not provided) as shown in Figure 1.

3. Connect tractor top link by inserting tractor clevis pin into top hitch point on rear blade frame assembly and secure (Figure 2).



Figure 1. Lower Lift Arm Attachment, Category 1



Figure 2. Top Link Connection

Quick Hitch (Category 1 Only)

The LRC and RBC will attach to a Category 1 quick hitch.

1. Use Bushing Kit 1004653 when using a quick coupler.
2. Place bushings over mounting pin and secure into position.
3. Align quick hitch with mounting pins and top hole on rear blade frame assembly.

Category 0 (Optional)

1. Place tractor 3-point lower lift arms over inner hitch pins.
2. Secure with safety pins (not provided) as shown in Figure 3.

3. Connect tractor top link by inserting tractor clevis pin into lower hitch point on rear blade frame assembly and secure (Figure 4).



Figure 3. Lower Lift Arm Attachment, Category 0



Figure 4. Top Link Connection

Category 0 / 1 Hitch Pin Kit (Optional)

1. Remove existing hitch pins.
2. Place hitch pin (1) through rear blade assembly.
3. Secure with flat washer (2), lock washer (3) and hex nut (4).
4. Repeat for opposite side.

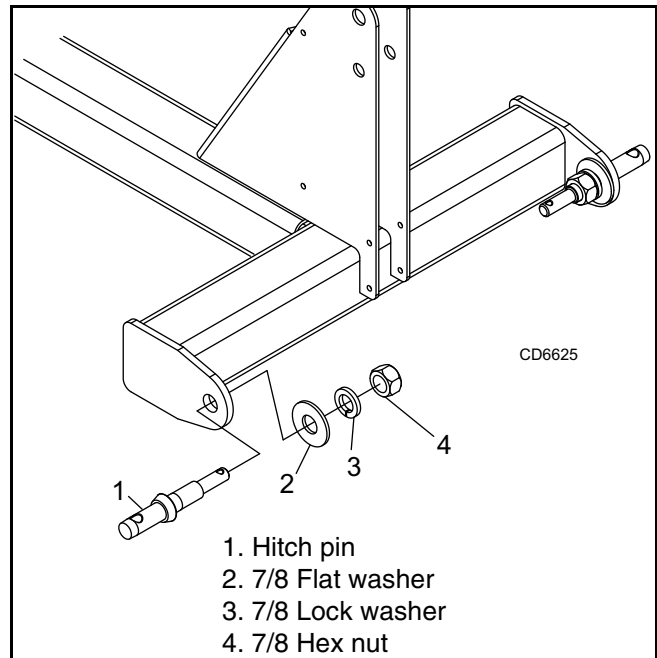

Figure 5. Hitch Pin Kit (Optional)

OPERATING TECHNIQUES

Level the A-frame and boom with 3-point connecting links and top link. Adjusting the top link length will change the fore and aft pitch of the tool.

Lengthening the top link will cause the tool to contact the ground with a sharper pitch and feed itself into the ground more readily.

When using the rake tool, you may need to adjust the tail wheels after adjusting pitch to maintain the desired working depth.

Position 3-point lift arm sway blocks or tighten sway chains to eliminate side sway. Install side braces if necessary.

Reversing (Blade or Rake)

For most tractors, the blade or rake may be rotated 360 degrees without unhooking from the tractor. To rotate without unhooking, pull hitch pin assembly.

Rotate to desired position; replace hitch pin assembly.

Angling (Blade or Rake)

Remove hitch pin assembly.

The blade or rake may be set 15 degrees or 30 degrees to the left or right for forward grading.

Offsetting (Blade Only)

The blade may be offset right or left 12" by moving moldboard on pivot assembly.

Only offset blade when operating in light material such as sand, loose soil, or snow.

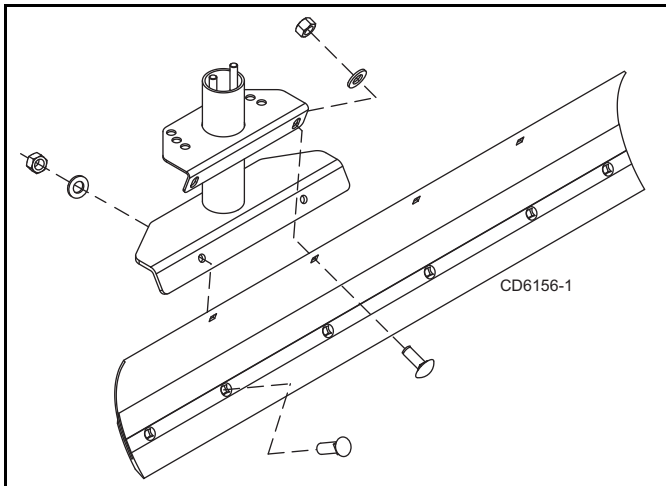

Figure 6. Moldboard Offset Left

Backfilling

Reverse blade for backfilling ditches or trenches (see Reversing).

The rake may also be used in light backfilling applications.

Cutting Ditches (Blade Only)

Angle blade to bring lower end forward. Bring lower point near the center line of the rear wheel track using 3-point hitch height adjustment.

Parking Stand Placement

Operating Position

1. Place parking stand (11) between 3-point mast plates as shown in Figure 7.
2. Secure into position using lock pin (20).

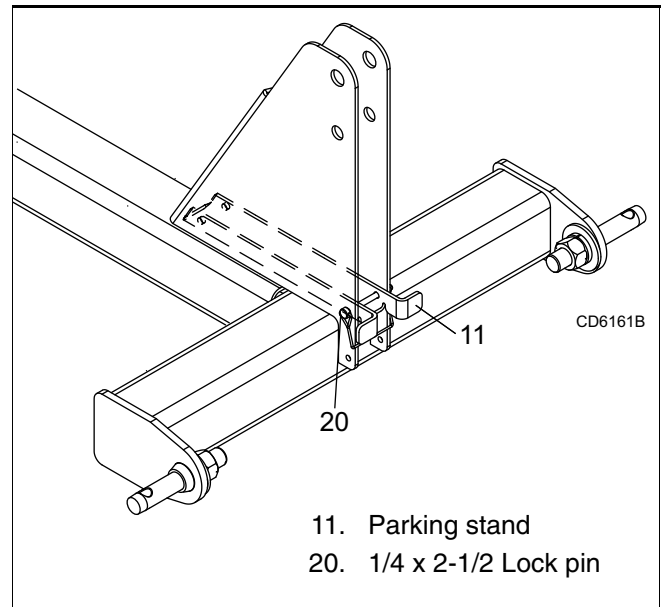

Figure 7. Parking Stand - Operating Position

Storage Position

1. Raise tractor 3-point lift arms.
2. Remove parking stand from operating position (Figure 7).
3. Align top holes on parking stand and lowest holes on 3-point mast plates as shown in Figure 8.
4. Secure into position using lock pin (20).



Figure 8. Parking Stand - Storage Position

PRE-OPERATION CHECK LIST

(Owner's Responsibility)

- ___ Review and follow all safety rules and safety decal instructions on pages 5 through 8.
- ___ Check that all safety decals are installed and in good condition. Replace if damaged.
- ___ Check that all hardware is properly installed and secured.
- ___ Check that equipment is properly and securely attached to tractor.
- ___ Do not allow riders.
- ___ Make sure tractor ROPS or ROPS cab and seat belt are in good condition. Keep seat belt securely fastened during operation.
- ___ Check that blade cutting edge is in good condition.
- ___ Consult local utilities before digging. Know location of and avoid contacting all underground cables, pipelines, overhead wires and other hazards in digging area.

MAINTENANCE

The information in this section is written for operators who possess basic mechanical skills. If you need help, your dealer has trained service technicians available. For your protection, read and follow all safety information in this manual.

WARNING

■ Before dismounting power unit or performing any service or maintenance, follow these steps: disengage power to equipment, lower the 3-point hitch and all raised components to the ground, operate valve levers to release any hydraulic pressure, set parking brake, stop engine, remove key, and unfasten seat belt.

■ NEVER GO UNDERNEATH EQUIPMENT. Never place any part of the body underneath equipment or between moveable parts even when the engine has been turned off. Hydraulic system leak down, hydraulic system failures, mechanical failures, or movement of control levers can cause equipment to drop or rotate unexpectedly and cause severe injury or death.

- Service work does not require going underneath.
- Read Operator's Manual for service instructions or have service performed by a qualified dealer.

■ Keep all persons away from operator control area while performing adjustments, service, or maintenance.

CAUTION

■ Always wear relatively tight and belted clothing to avoid entanglement in moving parts. Wear sturdy, rough-soled work shoes and protective equipment for eyes, hair, hands, hearing, and head; and respirator or filter mask where appropriate.

REPLACING BLADE CUTTING EDGE

Remove Cutting Edge

1. Remove plow bolts (27 & 28), hardened flat washers (25), and hex nuts (24).
2. Remove cutting edge (4) from moldboard (5) and replace with new cutting edge. Re-install hardware previously removed.

Reverse Cutting Edge

1. Remove plow bolts (27 & 28), hardened flat washer (25), and hex nuts (24).
2. Remove cutting edge (4) from moldboard and reverse cutting edge with sharp edge down. Re-install hardware previously removed.

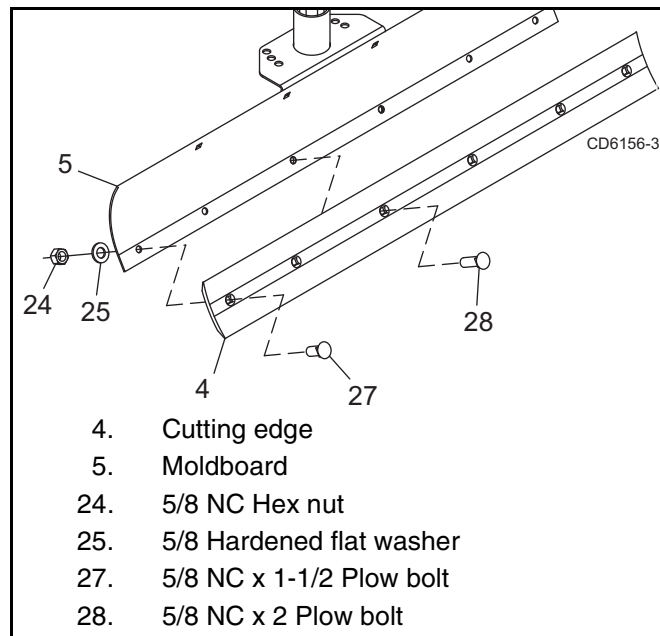

Figure 9. Cutting Edge Replacement

LRC60 TINE REPLACEMENT

NOTE: Tines should be replaced when they cannot be reformed to their original configuration.

1. Remove carriage bolt (22) and flange lock nut (23) from tine beam. Remove old tine.
2. Inset new tine, hole end first, into tine beam and align holes. Secure with bolt (22) and lock nut (23).

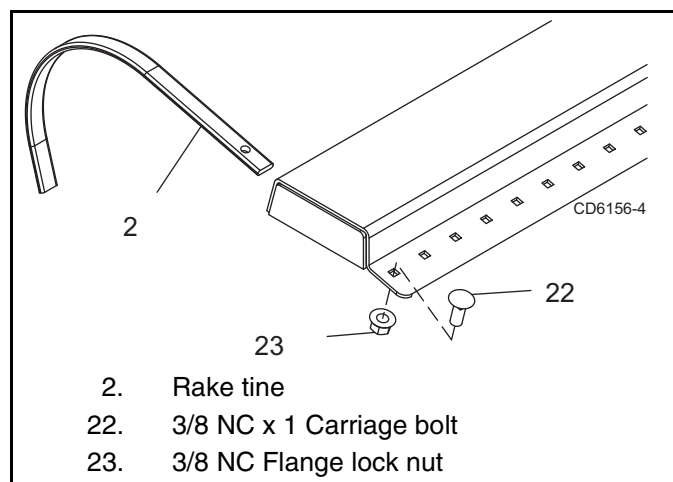

Figure 10. Rake Tine Replacement

TAIL WHEEL ADJUSTMENT LRC60 (OPTIONAL)

1. Raise rake until tail wheels clear the ground.
2. To raise tail wheels, remove klik pin (10) and washer (17). Allow clevis and shaft (7) to slide down in tail wheel arm (9). Do not remove shaft completely from wheel arm.
3. Rotate height adjustment spacer(s) (8), align slot with groove at bottom of shaft, and remove spacer(s).
4. Slide clevis and shaft back into position; place removed spacer(s) over top of shaft.
5. Install klik pin and washer.
6. To lower gauge wheels, reverse the procedure.

NOTE: Use a good multi-purpose to grease pivot tube and caster wheel every 8 hours of operation.

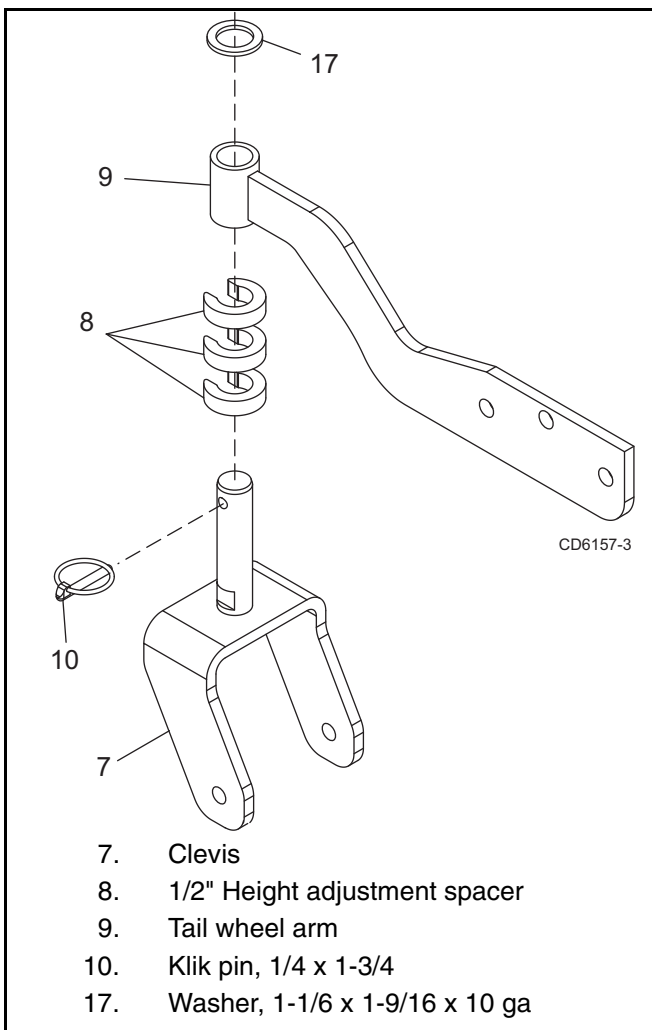

Figure 11. Caster Wheel Adjustment

CLEANING

After Each Use

- Remove large debris such as clumps of dirt, grass, crop residue, etc. from machine.
- Inspect machine and replace worn or damaged parts.
- Replace any safety decals that are missing or not readable.

Periodically or Before Extended Storage

- Clean large debris such as clumps of dirt, grass, crop residue, etc. from machine.
- Remove the remainder using a low-pressure water spray.
 1. Be careful when spraying near scratched or torn safety decals or near edges of decals as water spray can peel decal off surface.
 2. Be careful when spraying near chipped or scratched paint as water spray can lift paint.
 3. If a pressure washer is used, follow the advice of the pressure washer manufacturer.
- Inspect machine and replace worn or damaged parts.
- Sand down scratches and the edges of areas of missing paint and coat with Woods spray paint of matching color (purchase from your Woods dealer).
- Replace any safety decals that are missing or not readable (supplied free by your Woods dealer). See Safety Decals section for location drawing.

ASSEMBLY INSTRUCTIONS

DEALER SET-UP INSTRUCTIONS

Assembly of this Rear Blade/Landscape Rake is the responsibility of the WOODS dealer. It should be delivered to the owner completely assembled, lubricated and adjusted for normal cutting conditions.

The Rear Blade/Landscape Rake is shipped partially assembled. Assembly will be easier if components are aligned and loosely assembled before tightening hardware. Recommended torque values for hardware are located on page 24.

WARNING

■ **Before dismantling power unit or performing any service or maintenance, follow these steps: disengage power to equipment, lower the 3-point hitch and all raised components to the ground, operate valve levers to release any hydraulic pressure, set parking brake, stop engine, remove key, and unfasten seat belt.**

■ **NEVER GO UNDERNEATH EQUIPMENT.** Never place any part of the body underneath equipment or between moveable parts even when the engine has been turned off. Hydraulic system leak-down, hydraulic system failures, mechanical failures, or movement of control levers can cause equipment to drop or rotate unexpectedly and cause severe injury or death.

- Service work does not require going underneath.
- Read Operator's Manual for service instructions or have service performed by a qualified dealer.

■ **Keep all persons away from operator control area while performing adjustments, service, or maintenance.**

CAUTION

■ **Always wear relatively tight and belted clothing to avoid entanglement in moving parts. Wear sturdy, rough-soled work shoes and protective equipment for eyes, hair, hands, hearing, and head; and respirator or filter mask where appropriate.**

Assemble Blade

Attach Pivot Assembly to Moldboard

1. Remove two plow bolts (28) from center moldboard (5) and cutting edge.
2. Remove two carriage bolts (26) from top of moldboard.
3. Align holes on pivot assembly (6) with holes on moldboard.
4. Secure pivot assembly to moldboard using hardware previously remove. Use plow bolts (28), hardened flat washer (25), and hex nut (24) in the bottom two holes and carriage bolts (26), hardened flat washer (25), and hex nut (24) in the top two holes.

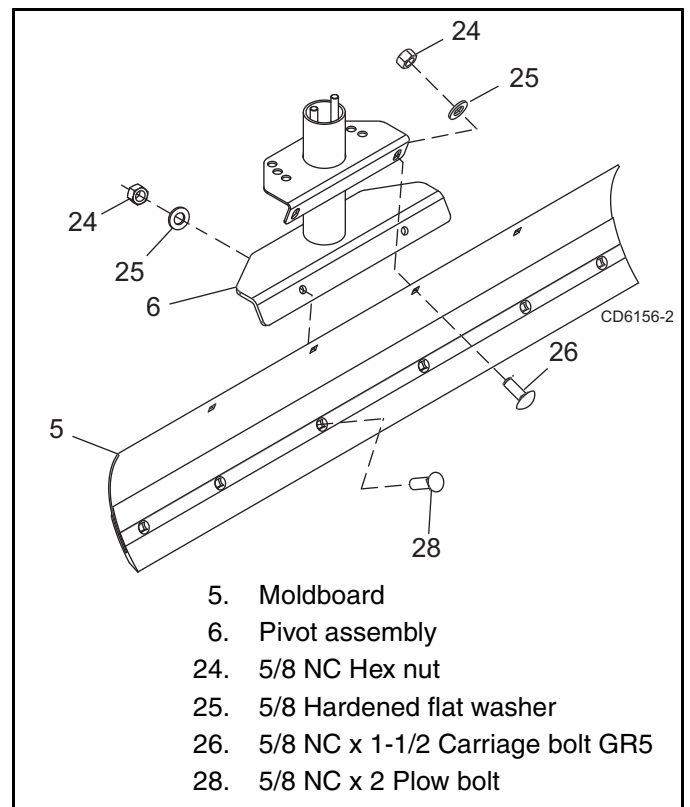

Figure 12. Pivot Assembly to Moldboard

Attach Rear Blade Frame to Pivot Assembly

1. Remove pivot cap (3) and hardware from pivot assembly (6).
2. Support moldboard in an upright position.
3. Place rear blade frame assembly (9) over pivot tube on pivot assembly (6).

- Secure rear blade frame assembly to pivot assembly using pivot cap (3), two hardened flat washers (25), and hex nuts (24).
- Place rear blade frame assembly in desired position and secure with hitch pin (8).
- Place parking stand in the down position to support rear blade. See page 11 for storage.

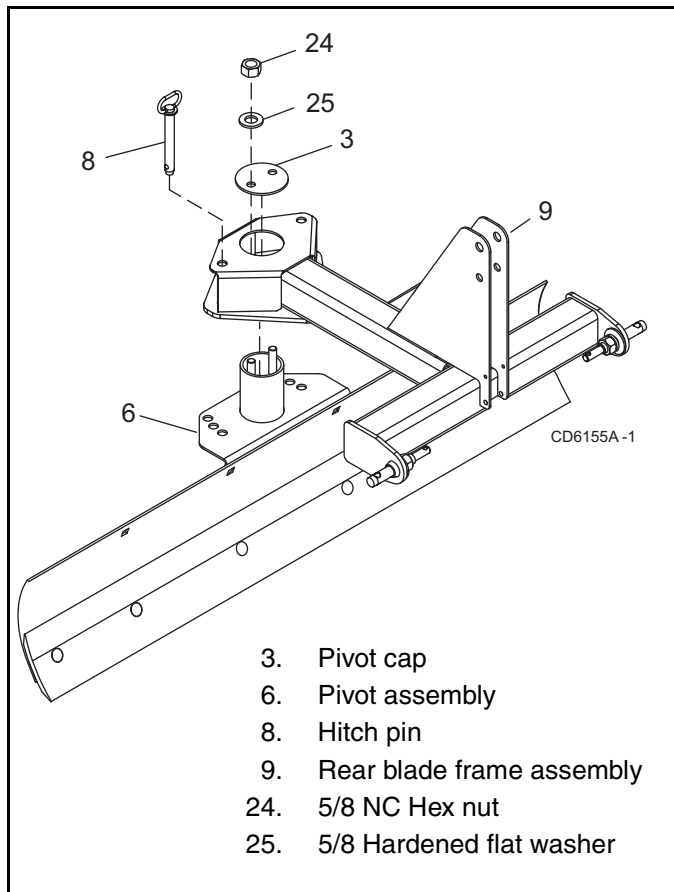

Figure 13. Rear Blade Frame to Pivot Assembly

Assembly Landscape Rake

- Place jack stands or suitable blocking device under tine beam so pivot tube is pointing upward.
- Remove pivot cap (3) and hardware from tine beam (1).
- Place rear blade frame assembly (9) over pivot tube on tine beam (1).
- Secure rear blade frame assembly to tine beam using pivot cap (3), two hardened flat washers (25), and hex nuts (24).
- Place rear blade frame assembly in desired position and secure with hitch pin (8).
- Place parking stand in storage position to support landscape rake. See page 11 for storage.

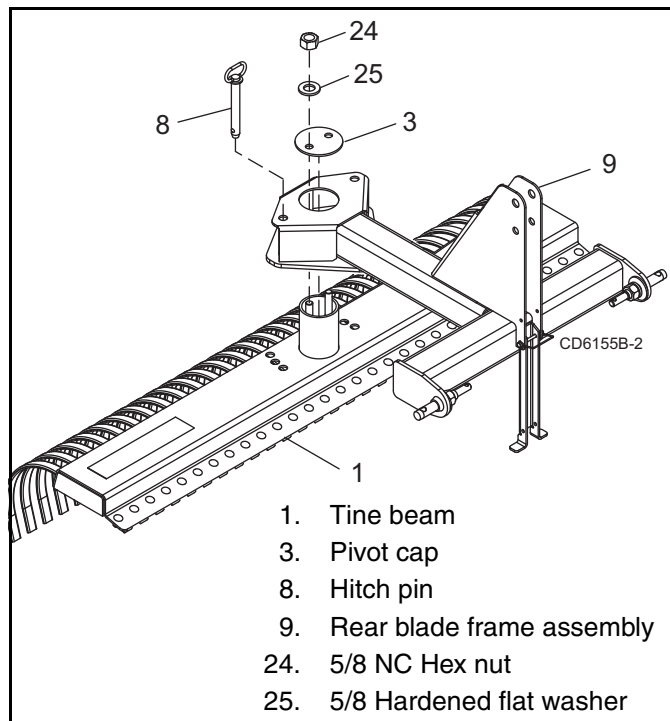

Figure 14. Landscape Rake Assembly

Install Optional Caster Wheels (Landscape Rake)

- Remove landscape rake from tractor 3-point lift arms if attached.
- Roll landscape rake over with tines pointing upward.
- Place jack stands or suitable blocking device under tine beam to raise tine beam approximately 8 to 10 inches.
- Place tail wheel arm (9) between lugs on tine beam and align holes.
- Secure into position using three cap screws (13) and flange lock nuts (12).

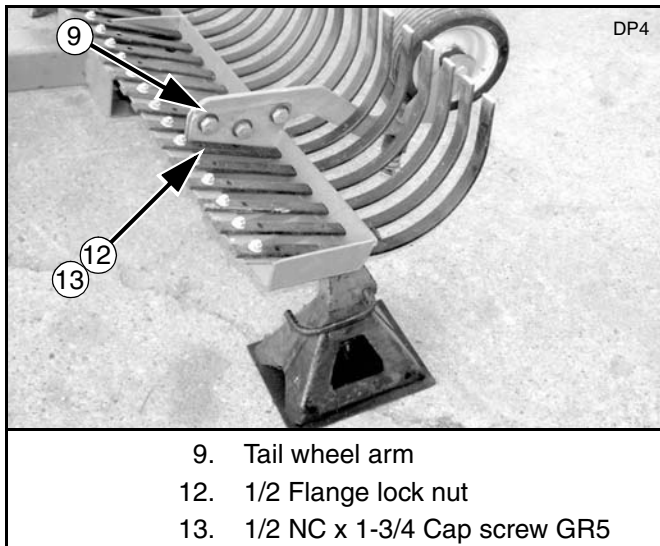

Figure 15. Caster Wheel Installed

- 9. Tail wheel arm
- 12. 1/2 Flange lock nut
- 13. 1/2 NC x 1-3/4 Cap screw GR5

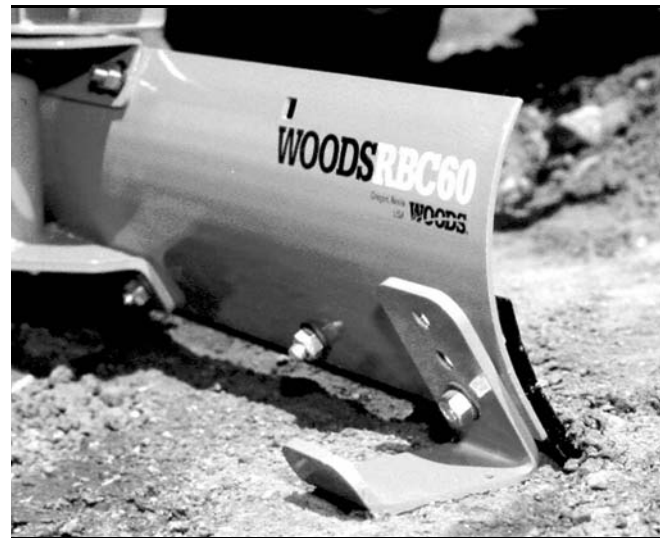

Figure 17. Skid Shoe Installed (Right Side)

Install Optional Skid Shoe Kit (Rear Blade)

1. Remove plow bolts from each end of cutting edge.
2. Attach skid shoe bracket (1) to rear of moldboard with plow bolt (2), washer (3), and hex nut (4) supplied in kit.
3. Adjust skid shoe to desired height.
4. Repeat steps for opposite side of moldboard.

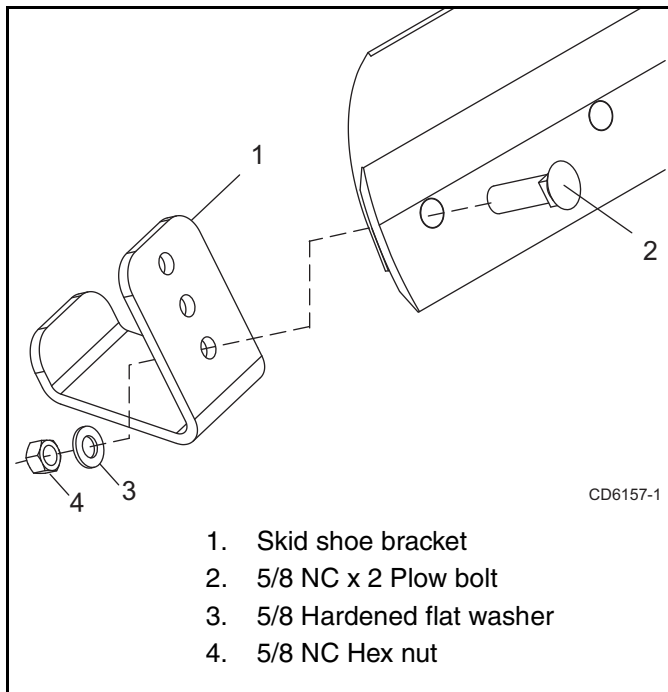

Figure 16. Skid Shoe Installation (Typical)

- 1. Skid shoe bracket
- 2. 5/8 NC x 2 Plow bolt
- 3. 5/8 Hardened flat washer
- 4. 5/8 NC Hex nut

Quick Hitch Bushing Kit (Optional)

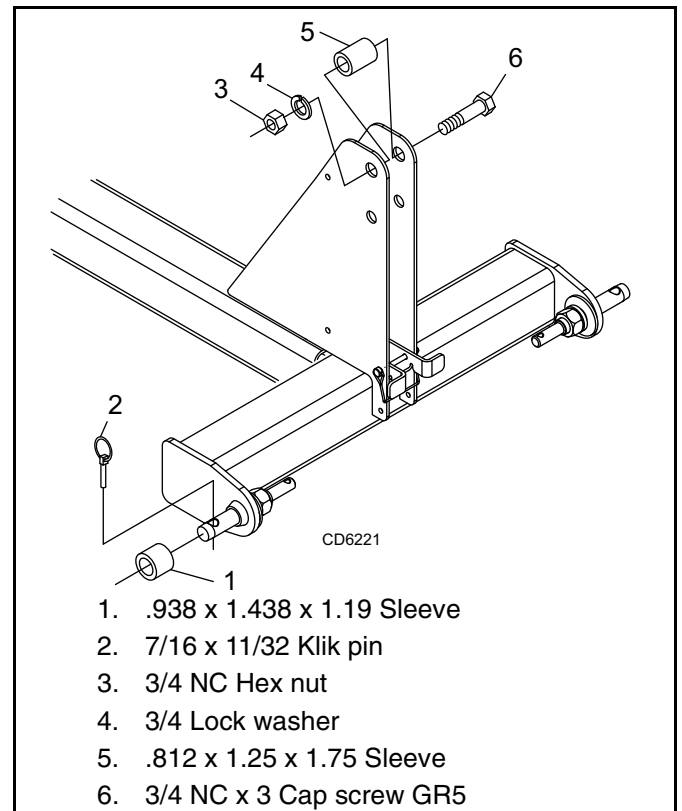

Figure 18. Quick Hitch Bushing Kit

1. Place sleeve (1) over lower 3-point pin, secure with klik pin (2). Repeat for opposite side.
2. Place sleeve (5) between A-frame plates. Secure through upper hole with cap screw (6), lock washer (4) and nut (3).

Manual Storage Tube Kit (Optional)

NOTE: May need to drill 2 - 9/32 (.281") holes 7-1/2" apart.

1. Slide two clamps (3) onto manual tube. Attach caps (2) to either end of the manual tube.
2. Attach manual tube to frame using two self tapping screws (4) and clamps (3) in the holes previously drilled.

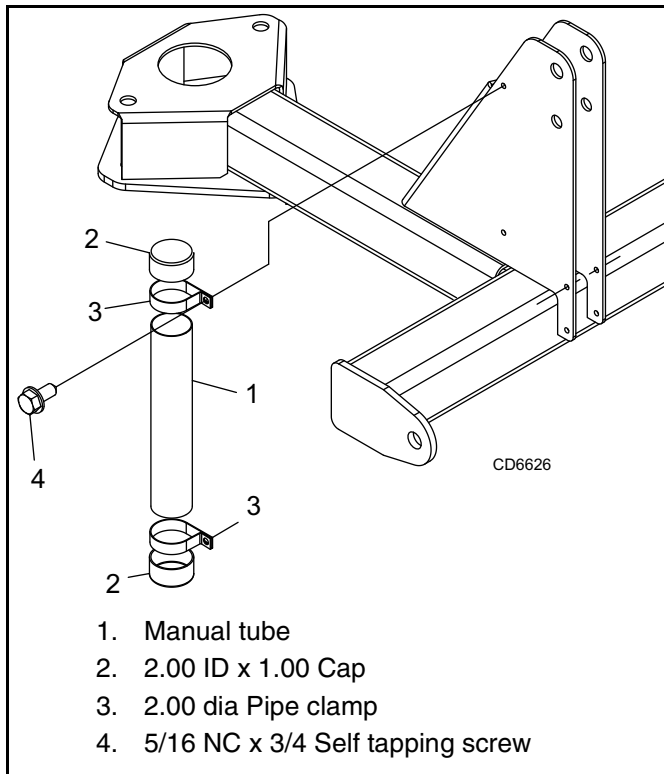

Figure 19. Manual Storage Tube Kit

DEALER CHECK LISTS

PRE-DELIVERY CHECK LIST

Inspect the equipment thoroughly after assembly to ensure it is set up properly before delivering it to the customer.

The following check lists are a reminder of points to inspect. Check off each item as it is found satisfactory or after proper adjustment is made.

- ___ Check that all safety decals are installed and in good condition. Replace if damaged.
- ___ Properly attach implement to tractor and make all necessary adjustments.
- ___ Check parking stand for proper operation.
- ___ Check all bolts to be sure they are properly torqued.
- ___ Check that all cotter pins and safety pins are properly installed. Replace if damaged.

DELIVERY CHECK LIST

- ___ Show customer how to make adjustments.
- ___ Instruct customer how to lubricate and explain importance of lubrication.
- ___ Point out the safety decals. Explain their meaning and the need to keep them in place and in good condition. Emphasize the increased safety hazards when instructions are not followed.
- ___ Present Operator's Manual and request that customer and all operators read it before operating equipment. Point out the manual safety rules, explain their meanings and emphasize the increased safety hazards that exist when safety rules are not followed.
- ___ Explain to customer the potential crushing hazards of going underneath raised equipment. Instruct customer that service work does not require going underneath unit and never to do so.
- ___ Show customer the safe, proper procedures to be used when mounting, dismounting, and storing equipment.
- ___ For mounted units, add wheel weights, ballast in front tires, and/or front tractor weight to enhance front end stability. A minimum 20% of tractor and equipment gross weight must be on front tractor wheels. When adding weight to attain 20% of tractor and equipment weight on front tractor wheels, you must not exceed the ROPS weight certification. Weigh the tractor and equipment. Do not estimate!
- ___ Make customer aware of optional equipment available so that customer can make proper choices as required.

RBC60/LRC60 ASSEMBLY

- 34 - Safety Decal Set, Complete
- 35 - Decal set LRC/RBC, Complete

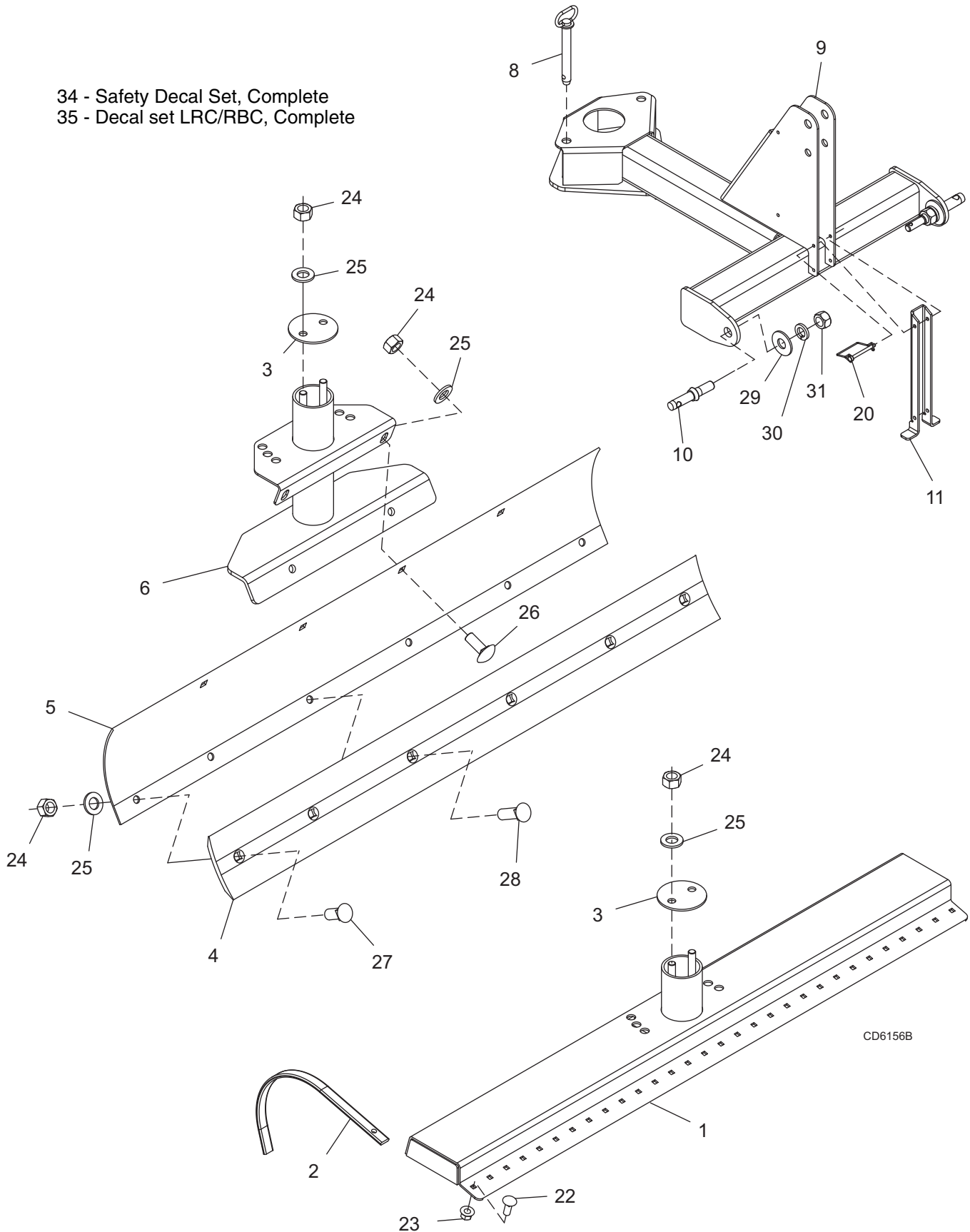

20 Parts

MAN0169 (Rev. 5/6/2005)

RBC60/LRC60 ASSEMBLY

REF	PART	QTY	DESCRIPTION	REF	PART	QTY	DESCRIPTION
1	1005349	1	LRC60 Tine beam	20	58047	1	Lock pin, 1/4 x 2-1/2
2	1005370	30	Rake tine, .31 x 1.0	22	6697	30	3/8 NC x 1 Carriage bolt GR5
3	1005354	1	Pivot cap, LRC/RBC	23	14350	30	3/8 NC Flange lock nut
4	27717	1	Cutting edge, .5 x 6 x 59	24	230	10	5/8 NC Hex nut
5	1005352	1	Moldboard, RBC60	25	57817	10	5/8 Hardened flat washer
6	1005355	1	Pivot assembly, RBC60	26	301130	2	5/8 NC x 1-1/2 Carriage bolt GR5
8	1004643	1	Hitch pin, .75 x 5.0 cotterless	27	25265	4	5/8 NC x 1-1/2 Plow bolt
9	1005360	1	Rear blade frame assembly	28	25266	2	5/8 NC x 2 Plow bolt
10	33661	2	Hitch pin, Cat 1 (includes items 30 & 31)	29	4258	2	7/8 Flat washer
11	1005376	1	Parking stand	30	30007	2	7/8 NF Hex nut
				31	30008	2	7/8 Lock washer
				34	1002882	1	Decal, Complete safety set LRC/RBC
				35	1002814	1	Decal, Complete set LRC/RBC

1009297 MANUAL STORAGE TUBE KIT (OPTIONAL)

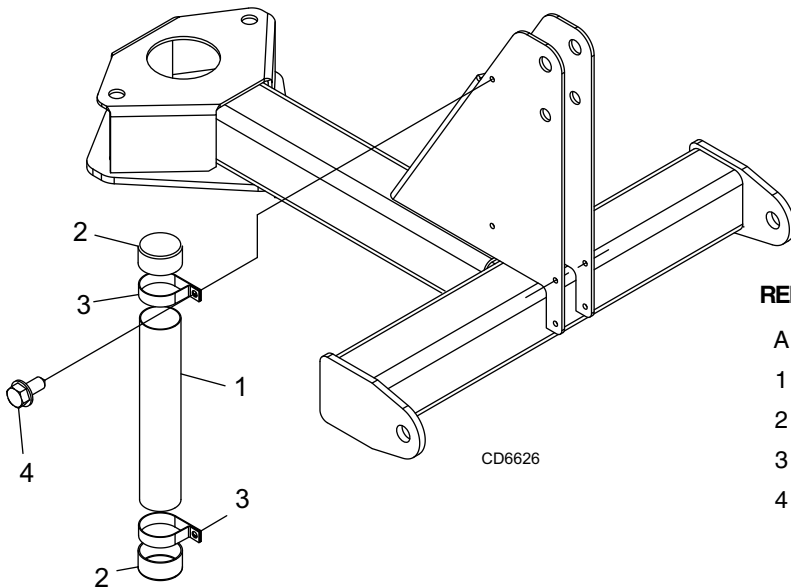

REF	PART	QTY	DESCRIPTION
A	1009297	1	Manual tube kit, white
1	1004656	1	Manual tube pvc 2.0 x 11.25
2	1004657	2	Caplug 2.00 ID x 1.00
3	1004658	2	Clamp, pipe 2.00 dia
4	30036	2	5/16 NC x 3/4 Self tap screw

RBC60 SKID SHOE & LRC60 TAIL WHEEL (OPTIONAL)

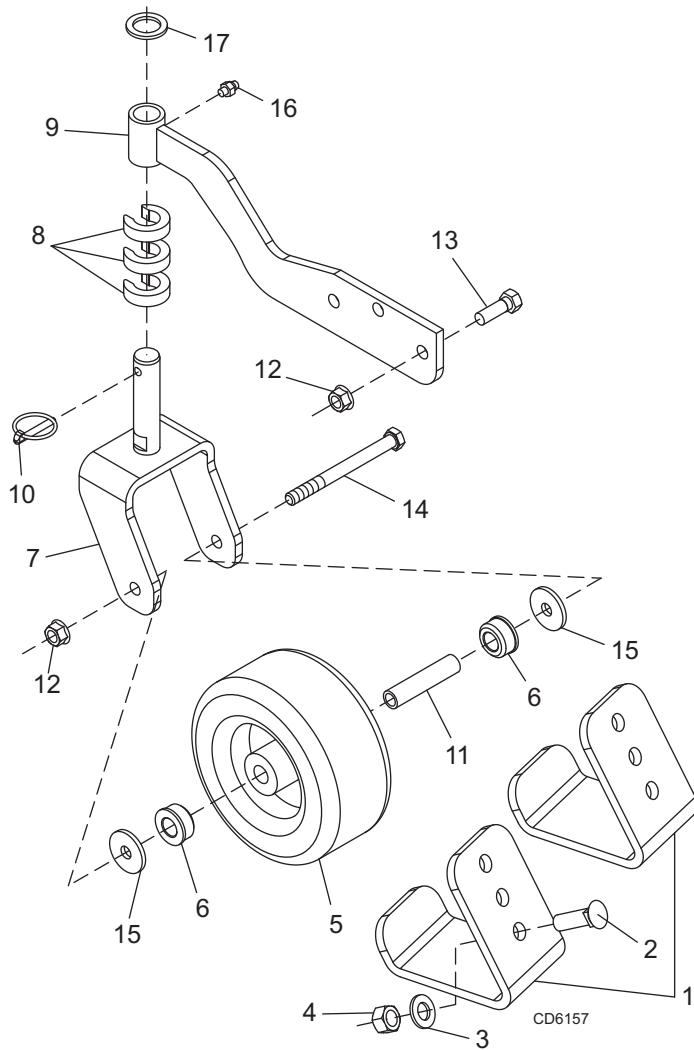

REF	PART	QTY	DESCRIPTION
1	1004646	1	Skid shoe kit, (includes items 2, 3, & 4)
2	25266	2	5/8 NC x 2 Plow bolt
3	57817	2	5/8 Hardened flat washer
4	230	2	5/8 NC Hex nut
5	19703	2	Wheel, 8" HD w/sleeve
6	65577	4	Bearing, .75 x 1.415 flange
7	1006306	2	Clevis
8	66207	6	Spacer, 1/2" adjustment
9	1006305	2	Tail wheel arm
10	62043	2	Klik pin, 1/4 x 1-3/4
11	29368	2	Sleeve, .50 x .75 x 3.38
12	11900	8	1/2 NC Flange lock nut
13	3379	6	1/2 NC x 1-1/2 Cap screw GR5
14	12305	2	1/2 NC x 5-1/2 Cap screw GR5
15	63757	4	1/2 x 1-3/4 x 7 ga Flat washer
16	7501	2	1/4-28 Grease fitting
17	31303	2	1-1/16 x 1-9/16 x 10 ga Washer

1004653 CATEGORY 1 QUICK HITCH BUSHING KIT (OPTIONAL)

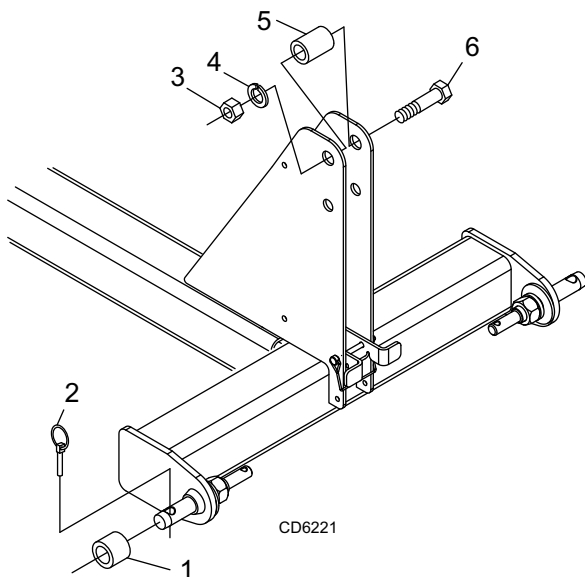

REF	PART	QTY	DESCRIPTION
1	1004660	2	.938 x 1.438 x 1.19 Sleeve
2	27542	2	7/16 x 11/32 Klik pin
3	1450	1	3/4 NC Hex nut plated
4	2522	1	3/4 Lock washer ZP
5	1004661	1	.812 x 1.25 x 1.75 Sleeve
6	14334	1	3/4 NC x 3 Cap screw GR5

22 Parts

MAN0169 (Rev. 5/6/2005)

1009298 CATEGORY 0 / 1 HITCH PIN KIT (OPTIONAL)

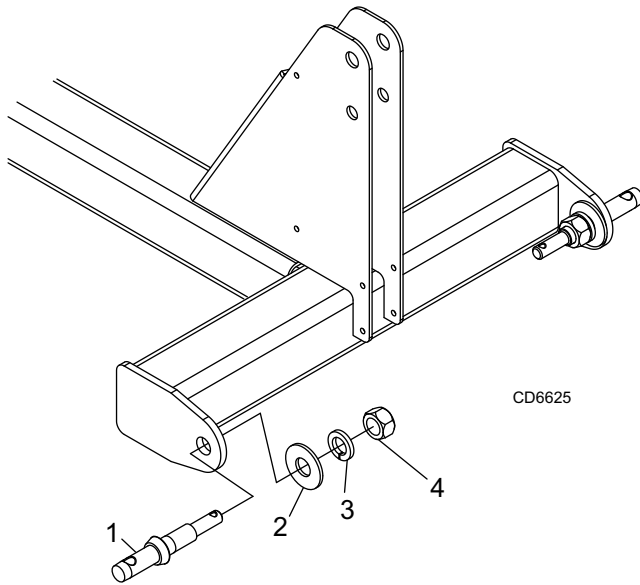

REF	PART	QTY	DESCRIPTION
1	1004626	2	Hitch pin Cat 0 / 1 (includes 3 and 4)
2	4258		7/8 Flat washer (included with blade/ rake)
3	30008	2	7/8 Lock washer
4	30007	2	7/8 MF Hex nut

BOLT TORQUE CHART

Always tighten hardware to these values unless a different torque value or tightening procedure is listed for a specific application.

Fasteners must always be replaced with the same grade as specified in the manual parts list.

Always use the proper tool for tightening hardware: SAE for SAE hardware and Metric for metric hardware.

Make sure fastener threads are clean and you start thread engagement properly.

All torque values are given to specifications used on hardware defined by SAE J1701 MAR 99 & J1701M JUL 96.

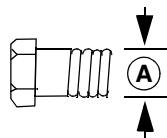

SAE SERIES TORQUE CHART



SAE Grade 2
(No Dashes)

SAE Bolt Head
Identification



SAE Grade 5
(3 Radial Dashes)



SAE Grade 8
(6 Radial Dashes)

Diameter (Inches)	Wrench Size	MARKING ON HEAD					
		SAE 2		SAE 5		SAE 8	
		lbs-ft	N-m	lbs-ft	N-m	lbs-ft	N-m
1/4"	7/16"	6	8	10	13	14	18
5/16"	1/2"	12	17	19	26	27	37
3/8"	9/16"	23	31	35	47	49	67
7/16"	5/8"	36	48	55	75	78	106
1/2"	3/4"	55	75	85	115	120	163
9/16"	13/16"	78	106	121	164	171	232
5/8"	15/16"	110	149	170	230	240	325
3/4"	1-1/8"	192	261	297	403	420	569
7/8"	1-5/16"	306	416	474	642	669	907
1"	1-1/2"	467	634	722	979	1020	1383

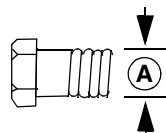

METRIC SERIES TORQUE CHART



Metric
Grade 8.8

Metric Bolt Head
Identification



Metric
Grade 10.9

Diameter & Thread Pitch (Millimeters)	Wrench Size	COARSE THREAD				FINE THREAD				Diameter & Thread Pitch (Millimeters)
		MARKING ON HEAD								
		Metric 8.8		Metric 10.9		Metric 8.8		Metric 10.9		
		N-m	lbs-ft	N-m	lbs-ft	N-m	lbs-ft	N-m	lbs-ft	
6 x 1.0	10 mm	8	6	11	8	8	6	11	8	6 x 1.0
8 x 1.25	13 mm	20	15	27	20	21	16	29	22	8 x 1.0
10 x 1.5	16 mm	39	29	54	40	41	30	57	42	10 x 1.25
12 x 1.75	18 mm	68	50	94	70	75	55	103	76	12 x 1.25
14 x 2.0	21 mm	109	80	151	111	118	87	163	120	14 x 1.5
16 x 2.0	24 mm	169	125	234	173	181	133	250	184	16 x 1.5
18 x 2.5	27 mm	234	172	323	239	263	194	363	268	18 x 1.5
20 x 2.5	30 mm	330	244	457	337	367	270	507	374	20 x 1.5
22 x 2.5	34 mm	451	332	623	460	495	365	684	505	22 x 1.5
24 x 3.0	36 mm	571	421	790	583	623	459	861	635	24 x 2.0
30 x 3.0	46 mm	1175	867	1626	1199	1258	928	1740	1283	30 x 2.0

Typical Washer Installations

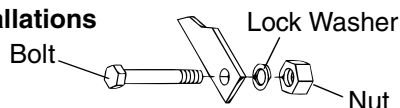

Flat Washer

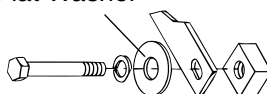

8/9/00

BOLT SIZE CHART

NOTE: Chart shows bolt thread sizes and corresponding head (wrench) sizes for standard SAE and metric bolts.

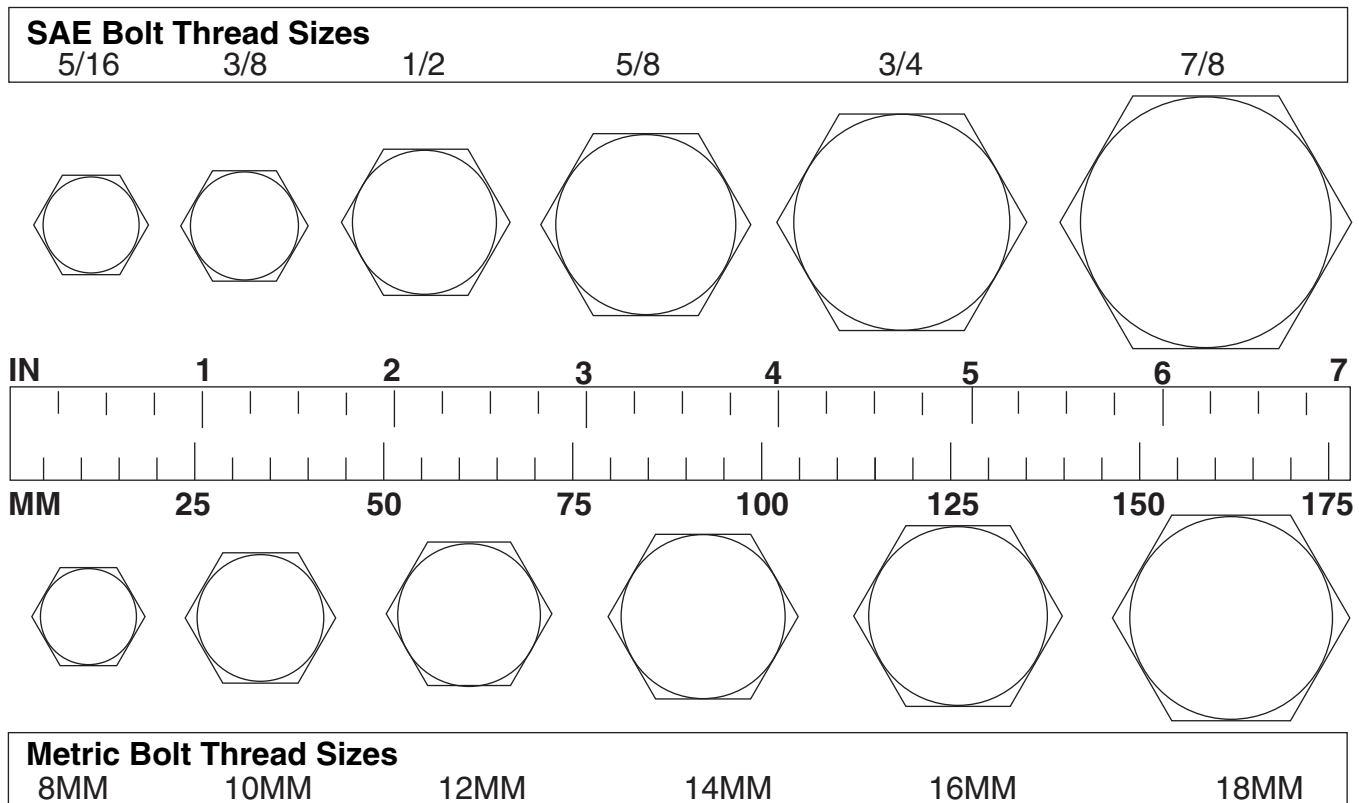

ABBREVIATIONS

AG Agriculture
 ATF Automatic Transmission Fluid
 BSPP British Standard Pipe Parallel
 BSPTM British Standard Pipe Tapered Male
 CV Constant Velocity
 CCW Counter-Clockwise
 CW Clockwise
 F Female
 GA Gauge
 GR (5, etc.) Grade (5, etc.)
 HHCS Hex Head Cap Screw
 HT Heat-Treated
 JIC Joint Industry Council 37° Degree Flare
 LH Left Hand
 LT Left
 m Meter
 mm Millimeter
 M Male
 MPa Mega Pascal
 N Newton

NC National Coarse
 NF National Fine
 NPSM National Pipe Straight Mechanical
 NPT National Pipe Tapered
 NPT SWF National Pipe Tapered Swivel Female
 ORBM O-Ring Boss - Male
 P Pitch
 PBY Power-Beyond
 psi Pounds per Square Inch
 PTO Power Take Off
 QD Quick Disconnect
 RH Right Hand
 ROPS Roll-Over Protective Structure
 RPM Revolutions Per Minute
 RT Right
 SAE Society of Automotive Engineers
 UNC Unified Coarse
 UNF Unified Fine
 UNS Unified Special



WARRANTY

All Models Except Mow'n Machine™ Zero-Turn Mowers

Please Enter Information Below and Save for Future Reference.

Date Purchased: _____ From (Dealer): _____

Model Number: _____ Serial Number: _____

Woods Equipment Company ("WOODS") warrants this product to be free from defect in material and workmanship. Except as otherwise set forth below, the duration of this Warranty shall be for TWELVE (12) MONTHS COMMENCING ON THE DATE OF DELIVERY OF THE PRODUCT TO THE ORIGINAL PURCHASER.

All current model loaders and backhoes are warranted for two (2) years from the date of delivery to the original purchaser.

The warranty periods for specific parts or conditions are listed below:

Part or Condition Warranted	Model Number	Duration (from date of delivery to the original purchaser)
Gearbox Seals	All units listed below	2 years
Gearbox components	BW1260, BW1620, BW1800, BW2400	8 years
	BW240HD, BW180HD, BW180HB, BW126HB	7 years
	BB48X, BB60X, BB72X, BB84X, BB600X, BB720X, BB840X, BB6000X, BB7200X, BB8400X, DS1260, DSO1260, DS1440, TS1680, BW126-3, BW180-3, BW240	6 years
	PHD25, PHD35, PHD65, PHD95, 2162, 3240, DS96, DS120, RCC42, RM550-2, RM660-2, RM990-3, PRD6000, PRD7200, PRD8400, 7144RD-2, 9180RD-2, 9204RD-2, S15CD, S20CD, S22CD, S25CD, S27CD, BW180LH, TC/R74, TC/R68, TC/R60	5 years
	RDC54, RD60, RD72, TBW150C, TS/R60, TS/R52, TS/R44	3 years (1 year if used in rental or commercial applications)
Blade spindles	RM550-2, RM660-2, RM990-3, PRD6000, PRD7200, PRD8400, 7144RD-2, 9180RD-2, 9204RD-2	3 years
Rust-through	BB600, BB720, BB840, BB6000, BB7200, BB8400, BW126-3, BW126HB, BW180-3, BW180HB, BW180HD, BW1260, BW1800, BW240, BW240HD, 2162, 3240, DS1260, DSO1260, DS1440, TS1680	10 years

Under no circumstances will this Warranty apply in the event that the product, in the good faith opinion of WOODS, has been subjected to improper operation, improper maintenance, misuse, or an accident. This Warranty does not apply in the event that the product has been materially modified or repaired by someone other than WOODS, a WOODS authorized dealer or distributor, and/or a WOODS authorized service center. This Warranty does not cover normal wear or tear, or normal maintenance items. This Warranty also does not cover repairs made with parts other than those obtainable through WOODS.

This Warranty is extended solely to the original purchaser of the product. Should the original purchaser sell or otherwise transfer this product to a third party, this Warranty does not transfer to the third party purchaser in any way. There are no third party beneficiaries of this Warranty.

WOODS makes no warranty, express or implied, with respect to engines, batteries, tires or other parts or accessories not manufactured by WOODS. Warranties for these items, if any, are provided separately by their respective manufacturers.

WOODS' obligation under this Warranty is limited to, at WOODS' option, the repair or replacement, free of charge, of the product if WOODS, in its sole discretion, deems it to be defective or in noncompliance with this Warranty. **The product must be returned to WOODS with proof of purchase within thirty (30) days after such defect or noncompliance is discovered or should have been discovered, routed through the dealer and distributor from whom the purchase was made, transportation charges prepaid.** WOODS shall complete such repair or replacement within a reasonable time after WOODS receives the product. **THERE ARE NO OTHER REMEDIES UNDER THIS WARRANTY. THE REMEDY OF REPAIR OR REPLACEMENT IS THE SOLE AND EXCLUSIVE REMEDY UNDER THIS WARRANTY.**

THERE ARE NO WARRANTIES WHICH EXTEND BEYOND THE DESCRIPTION ON THE FACE OF THIS WARRANTY. WOODS MAKES NO OTHER WARRANTY, EXPRESS OR IMPLIED, AND WOODS SPECIFICALLY DISCLAIMS ANY IMPLIED WARRANTY OF MERCHANTABILITY AND/OR ANY IMPLIED WARRANTY OF FITNESS FOR A PARTICULAR PURPOSE.

WOODS shall not be liable for any incidental or consequential losses, damages or expenses, arising directly or indirectly from the product, whether such claim is based upon breach of contract, breach of warranty, negligence, strict liability in tort or any other legal theory. Without limiting the generality of the foregoing, Woods specifically disclaims any damages relating to (i) lost profits, business, revenues or goodwill; (ii) loss of crops; (iii) loss because of delay in harvesting; (iv) any expense or loss incurred for labor, supplies, substitute machinery or rental; or (v) any other type of damage to property or economic loss.

This Warranty is subject to any existing conditions of supply which may directly affect WOODS' ability to obtain materials or manufacture replacement parts.

No agent, representative, dealer, distributor, serviceperson, salesperson, or employee of any company, including without limitation, WOODS, its authorized dealers, distributors, and service centers, authorized to enlarge this Warranty. Answers to any questions regarding warranty service and locations may be obtained by contacting:

- ALITEC™**
- BMP®**
- CENTRAL FABRICATORS®**
- GANNON®**
- GILL®**
- WAIN-ROY®**
- WOODS®**



Woods Equipment Company

2606 South Illinois Route 2
Post Office Box 1000
Oregon, Illinois 61061 USA

800-319-6637 tel
800-399-6637 fax
www.WoodsEquipment.com



WARRANTY

(Replacement Parts For All Models Except Mow'n Machine™
Zero-Turn Mowers and Woods Boundary™ Utility Vehicles)

Woods Equipment Company ("WOODS") warrants this product to be free from defect in material and workmanship for a period of ninety (90) days from the date of delivery of the product to the original purchaser with the exception of V-belts, which will be free of defect in material and workmanship for a period of 12 months.

Under no circumstances will this Warranty apply in the event that the product, in the good faith opinion of WOODS, has been subjected to improper operation, improper maintenance, misuse, or an accident. This Warranty does not cover normal wear or tear, or normal maintenance items.

This Warranty is extended solely to the original purchaser of the product. Should the original purchaser sell or otherwise transfer this product to a third party, this Warranty does not transfer to the third party purchaser in any way. There are no third party beneficiaries of this Warranty.

WOODS' obligation under this Warranty is limited to, at WOODS' option, the repair or replacement, free of charge, of the product if WOODS, in its sole discretion, deems it to be defective or in noncompliance with this Warranty. **The product must be returned to WOODS with proof of purchase within thirty (30) days after such defect or noncompliance is discovered or should have been discovered, routed through the dealer and distributor from whom the purchase was made, transportation charges prepaid.** WOODS shall complete such repair or replacement within a reasonable time after WOODS receives the product. THERE ARE NO OTHER REMEDIES UNDER THIS WARRANTY. THE REMEDY OF REPAIR OR REPLACEMENT IS THE SOLE AND EXCLUSIVE REMEDY UNDER THIS WARRANTY.

THERE ARE NO WARRANTIES WHICH EXTEND BEYOND THE DESCRIPTION ON THE FACE OF THIS WARRANTY. WOODS MAKES NO OTHER WARRANTY, EXPRESS OR IMPLIED, AND WOODS SPECIFICALLY DISCLAIMS ANY IMPLIED WARRANTY OF MERCHANTABILITY AND/OR ANY IMPLIED WARRANTY OF FITNESS FOR A PARTICULAR PURPOSE.

WOODS shall not be liable for any incidental or consequential losses, damages or expenses, arising directly or indirectly from the product, whether such claim is based upon breach of contract, breach of warranty, negligence, strict liability in tort or any other legal theory. Without limiting the generality of the foregoing, Woods specifically disclaims any damages relating to (i) lost profits, business, revenues or goodwill; (ii) loss of crops; (iii) loss because of delay in harvesting; (iv) any expense or loss incurred for labor, supplies, substitute machinery or rental; or (v) any other type of damage to property or economic loss.

This Warranty is subject to any existing conditions of supply which may directly affect WOODS' ability to obtain materials or manufacture replacement parts.

No agent, representative, dealer, distributor, service person, salesperson, or employee of any company, including without limitation, WOODS, its authorized dealers, distributors, and service centers, is authorized to alter, modify, or enlarge this Warranty.

Answers to any questions regarding warranty service and locations may be obtained by contacting:

Woods Equipment Company

2606 South Illinois Route 2
Post Office Box 1000
Oregon IL 61061

800-319-6637 tel
800-399-6637 fax
www.WoodsEquipment.com

WOODS®

ALITEC™
BMP®
CENTRAL FABRICATORS®
GANNON®
GILL®
WAIN-ROY®
WOODS®

PART NO.
MAN0169

815-732-2141 tel
815-732-7580 fax
www.WoodsEquipment.com

WOODS®

© 2004 Woods Equipment Company. All rights reserved. WOODS, the Woods logo, and "Tested. Proven. Unbeatable." are trademarks of Woods Equipment Company. All other trademarks, trade names, or service marks not owned by Woods Equipment Company that appear in this manual are the property of their respective companies or mark holders. Specifications subject to change without notice.

Free Manuals Download Website

<http://myh66.com>

<http://usermanuals.us>

<http://www.somanuals.com>

<http://www.4manuals.cc>

<http://www.manual-lib.com>

<http://www.404manual.com>

<http://www.luxmanual.com>

<http://aubethermostatmanual.com>

Golf course search by state

<http://golfingnear.com>

Email search by domain

<http://emailbydomain.com>

Auto manuals search

<http://auto.somanuals.com>

TV manuals search

<http://tv.somanuals.com>