

WOODS

UNDERMOUNT

MOWER

L306 K50

For Use on Kubota Tractors:

L2250F

L2250DT

L2550F

L2550DT

L2850F

L2850DT

with Ag or Turf Tires

32695

Rev. 11/17/2006

WOODS®

Tested. Proven. Unbeatable.

OPERATOR'S MANUAL

TO THE DEALER:

Assembly and proper installation of this product is the responsibility of the Woods® dealer. Read manual instructions and safety rules. Make sure all items on the Dealer's Pre-Delivery and Delivery Check Lists in the Operator's Manual are completed before releasing equipment to the owner.

The dealer must complete the Product Registration included with the Operator's Manual. The customer must sign the registration which certifies that all Dealer Check List items have been completed. The dealer is to return the prepaid postage portion to Woods, give one copy to the customer, and retain one copy. **Failure to complete and return this card does not diminish customer's warranty rights.**

TO THE OWNER:

Read this manual before operating your Woods equipment. The information presented will prepare you to do a better and safer job. Keep this manual handy for ready reference. Require all operators to read this manual carefully and become acquainted with all adjustment and operating procedures before attempting to operate. Replacement manuals can be obtained from your dealer. To locate your nearest dealer, check the Dealer Locator at www.WoodsEquipment.com, or in the United States and Canada call 1-800-319-6637.

The equipment you have purchased has been carefully engineered and manufactured to provide dependable and satisfactory use. Like all mechanical products, it will require cleaning and upkeep. Lubricate the unit as specified. Observe all safety information in this manual and safety decals on the equipment.

For service, your authorized Woods dealer has trained mechanics, genuine Woods service parts, and the necessary tools and equipment to handle all your needs.

Use only genuine Woods service parts. Substitute parts will void the warranty and may not meet standards required for safe and satisfactory operation. Record the model number and serial number of your equipment in the spaces provided:

Model: _____ **Date of Purchase:** _____

Serial Number: (see Safety Decal section for location) _____

Provide this information to your dealer to obtain correct repair parts.

Throughout this manual, the term **IMPORTANT** is used to indicate that failure to observe can cause damage to equipment. The terms **CAUTION**, **WARNING**, and **DANGER** are used in conjunction with the Safety-Alert Symbol (a triangle with an exclamation mark) to indicate the degree of hazard for items of personal safety.



This Safety-Alert Symbol indicates a hazard and means **ATTENTION! BECOME ALERT! YOUR SAFETY IS INVOLVED!**



DANGER

Indicates an imminently hazardous situation that, if not avoided, will result in death or serious injury.



WARNING

Indicates a potentially hazardous situation that, if not avoided, could result in death or serious injury, and includes hazards that are exposed when guards are removed.



CAUTION

Indicates a potentially hazardous situation that, if not avoided, may result in minor or moderate injury.

IMPORTANT

Indicates that failure to observe can cause damage to equipment.

NOTE

Indicates helpful information.

WOODS®

ALITEC™

BMP®

CENTRAL FABRICATORS®

GANNON®

GILL®

WAIN-ROY®

WOODS®

2 Introduction

Gen'1 (Rev. 6/6/2005)

TABLE OF CONTENTS

INTRODUCTION	2
SPECIFICATIONS	4
GENERAL INFORMATION	4
SAFETY RULES	5
SAFETY DECALS	7
OPERATION	8
OWNER SERVICE	12
DEALER SERVICE	14
TROUBLESHOOTING	16
ASSEMBLY	18
OPTIONAL EQUIPMENT	24
DEALER CHECK LISTS	27
PARTS LISTS	28
BOLT TORQUE CHART	35
BOLT SIZE CHART & ABBREVIATIONS	36
INDEX	38
REPLACEMENT PARTS WARRANTY	39
PRODUCT WARRANTY	INSIDE BACK COVER

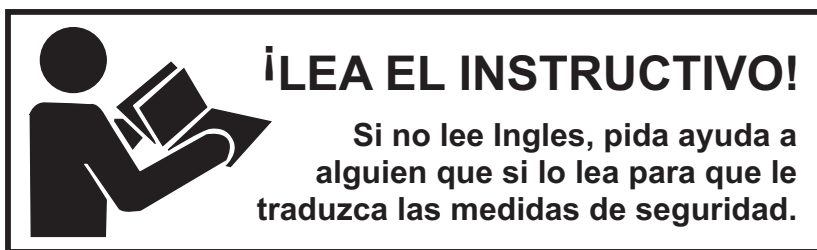

This Operator's Manual should be regarded as part of the machine. Suppliers of both new and second-hand machines must make sure that this manual is provided with the machine.

SPECIFICATIONS

Cutting Width	72"
Cutting Height Range	1-1/2 - 4-1/4
Blade Speed (RPM)	2,180
Blade Tip Speed (feet per minute)	13,840
Blade Spindles	3
Number of Blades	3
Caster Wheels	Optional
Caster Size	3-1/4 x 10-1/4
PTO Speed	1,000 Rpm
Mower Frame Thickness	7 GA Deck

GENERAL INFORMATION

The purpose of this manual is to assist you in operating and maintaining your mower. Read it carefully. It furnishes information and instructions that will help you achieve years of dependable performance. These instructions have been compiled from extensive field experience and engineering data. Some information may be general in nature, due to unknown and varying operating conditions. However, through experience and these instructions, you should be able to develop procedures suitable to your particular situation.

The illustrations and data used in this manual were current at the time of printing. However, due to possible inline production changes, your machine may vary slightly in detail. We reserve the right to redesign and change the machines as may be necessary without notification.

Throughout this manual, references are made to right and left directions. These are determined by standing behind the tractor facing the direction of forward travel. Blade rotation is counter-clockwise as viewed from the top of the mower.

 **WARNING**

■ Some illustrations in this manual show the mower with safety shields removed to provide a better view. The mower should never be operated with any safety shielding removed.

SAFETY RULES



ATTENTION! BECOME ALERT! YOUR SAFETY IS INVOLVED!



Safety is a primary concern in the design and manufacture of our products. Unfortunately, our efforts to provide safe equipment can be wiped out by an operator's single careless act.

In addition to the design and configuration of equipment, hazard control and accident prevention are dependent upon the awareness, concern, judgement, and proper training of personnel involved in the operation, transport, maintenance, and storage of equipment.

It has been said, "The best safety device is an informed, careful operator." We ask you to be that kind of operator.

TRAINING

- **Safety instructions are important! Read all attachment and power unit manuals; follow all safety rules and safety decal information. (Replacement manuals and safety decals are available from your dealer. To locate your nearest dealer, check the Dealer Locator at www.WoodsEquipment.com, or in the United States and Canada call 1-800-319-6637.) Failure to follow instructions or safety rules can result in serious injury or death.**
- **If you do not understand any part of this manual and need assistance, see your dealer.**
- **Know your controls and how to stop engine and attachment quickly in an emergency.**
- **Operators must be instructed in and be capable of the safe operation of the equipment, its attachments, and all controls. Do not allow anyone to operate this equipment without proper instructions.**
- **Never allow children or untrained persons to operate equipment.**

PREPARATION

- **Check that all hardware is properly installed. Always tighten to torque chart specifications unless instructed otherwise in this manual.**
- **Always wear relatively tight and belted clothing to avoid getting caught in moving parts. Wear sturdy, rough-soled work shoes and protective equipment for eyes, hair, hands, hearing, and head; and respirator or filter mask where appropriate.**
- **Make sure attachment is properly secured, adjusted, and in good operating condition.**
- **Remove accumulated debris from this equipment, power unit, and engine to avoid fire hazard.**

- **Make sure all safety decals are installed. Replace if damaged. (See Safety Decals section for location.)**

- **Make sure shields and guards are properly installed and in good condition. Replace if damaged.**

- **Inspect and clear area of stones, branches, or other hard objects that might be thrown, causing injury or damage.**

OPERATION

- **You may not be able to stop the tractor safely if the clutch or brake pedal mechanisms are improperly adjusted, allowing them to contact mower components.**

- **When the mower lift stops are installed as instructed in this manual, properly adjusted clutch and brake pedal mechanisms will not contact mower components. You should frequently check that the tractor clutch and brake pedal mechanisms are in adjustment.**

- **If the clutch or brake pedal mechanisms can contact mower components, do not put mower into service until properly adjusted.**

- **Do not put mower into service unless discharge chute is installed and in good condition. Replace if damaged.**

- **Keep bystanders away from equipment.**

- **Do not operate or transport equipment while under the influence of alcohol or drugs.**

- **Never direct discharge toward people, animals, or property.**

- **Operate only in daylight or good artificial light.**

- **Keep hands, feet, hair, and clothing away from equipment while engine is running. Stay clear of all moving parts.**

- **Always comply with all state and local lighting and marking requirements.**

- **Never allow riders on power unit or attachment.**

- **Always sit in power unit seat when operating controls or starting engine. Place transmission in neutral, engage brake, and ensure all other controls are disengaged before starting power unit engine.**

- **Look down and to the rear and make sure area is clear before operating in reverse.**

- **Do not operate or transport on steep slopes.**

SAFETY RULES



ATTENTION! BECOME ALERT! YOUR SAFETY IS INVOLVED!



- Do not stop, start, or change directions suddenly on slopes.
- Use extreme care and reduce ground speed on slopes and rough terrain.
- Watch for hidden hazards on the terrain during operation.
- Stop power unit and equipment immediately upon striking an obstruction. Turn off engine, remove key, inspect, and repair any damage before resuming operation.

TRANSPORTATION

- Always comply with all state and local lighting and marking requirements.
- Never allow riders on power unit or attachment.
- Do not operate PTO during transport.
- Watch for hidden hazards on the terrain.
- Do not operate or transport on steep slopes.
- Do not operate or transport equipment while under the influence of alcohol or drugs.

MAINTENANCE

- Before dismounting power unit or performing any service or maintenance, follow these steps: disengage power to equipment, lower the 3-point hitch and all raised components to the ground, operate valve levers to release any hydraulic pressure, set parking brake, stop engine, remove key, and unfasten seat belt.
- Do not modify or alter or permit anyone else to modify or alter the equipment or any of its components in any way.
- Always wear relatively tight and belted clothing to avoid getting caught in moving parts. Wear sturdy, rough-soled work shoes and protective equipment for eyes, hair, hands, hearing, and head; and respirator or filter mask where appropriate.
- Never go underneath equipment (lowered to the ground or raised) unless it is properly blocked and secured. Never place any part of the body underneath equipment or between moveable parts even when the engine has been turned off. Hydraulic

system leak down, hydraulic system failures, mechanical failures, or movement of control levers can cause equipment to drop or rotate unexpectedly and cause severe injury or death. Follow Operator's Manual instructions for working underneath and blocking requirements or have work done by a qualified dealer.

- Make sure attachment is properly secured, adjusted, and in good operating condition.
- Keep all persons away from operator control area while performing adjustments, service, or maintenance.
- Make certain all movement of equipment components has stopped before approaching for service.
- Frequently check blades. They should be sharp, free of nicks and cracks, and securely fastened.
- Do not handle blades with bare hands. Careless or improper handling may result in serious injury.
- Your dealer can supply genuine replacement blades. Substitute blades may not meet original equipment specifications and may be dangerous.
- Tighten all bolts, nuts, and screws to torque chart specifications. Check that all cotter pins are installed securely to ensure equipment is in a safe condition before putting unit into service.
- Make sure all safety decals are installed. Replace if damaged. (See Safety Decals section for location.)
- Make sure shields and guards are properly installed and in good condition. Replace if damaged.
- Wear gloves when installing belt. Be careful to prevent fingers from being caught between belt and pulley.

STORAGE

- Block equipment securely for storage.
- Keep children and bystanders away from storage area.





SAFETY & INSTRUCTIONAL DECALS

ATTENTION! BECOME ALERT! YOUR SAFETY IS INVOLVED!
Replace Immediately If Damaged!

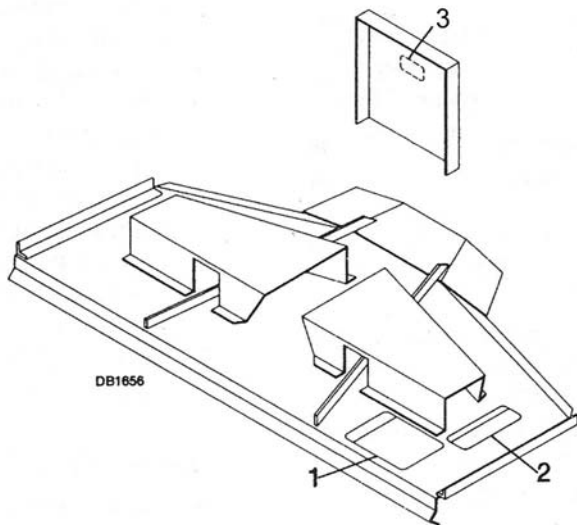

2 - PN 53425

DANGER

**ROTATING BLADES AND
THROWN OBJECTS**

- Do not put hands or feet under or into mower when engine is running.
- Before mowing, clear area of objects that may be thrown by blade.
- Keep bystanders away.
- Keep discharge chute and guards in place and in good condition.

**BLADE CONTACT OR THROWN OBJECTS CAN
CAUSE SERIOUS INJURY OR DEATH.**

53425-B

BE CAREFUL!

Use a clean, damp cloth to clean safety decals. Avoid spraying too close to decals when using a pressure washer; high-pressure water can enter through very small scratches or under edges of decals causing them to peel or come off.

Replacement safety decals can be ordered free from your Woods dealer. To locate your nearest dealer, check the Dealer Locator at www.WoodsEquipment.com, or in the United States and Canada call 1-800-319-6637.

Serial Number Plate

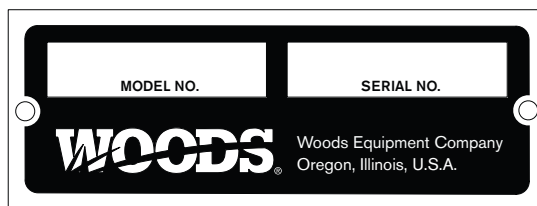

1 - PN 25505

WARNING

**TO AVOID SERIOUS
INJURY OR DEATH,**

- Read Operator's Manual and follow all safety precautions. (Contact dealer for manuals.)
- Keep shields and guards in place. Keep clear of drives and belts.
- Lower implement, stop engine and remove key before dismounting.
- Block up implement and remove key before working underneath.
- Do not operate mower in vicinity of other persons. Never allow riders.
- Know how to stop tractor and equipment quickly in an emergency.
- Clear mowing area of debris.
- Never allow children or unqualified persons to operate equipment.
- Be careful on uneven terrain. Decrease speed when turning.
- Do not operate in transport position.

25505-G

3 - PN 26451

WARNING

For tractors having 2 or 3 speed PTO, operate between 800 and 1000 rpm PTO.

Higher PTO speed may result in personal injury or equipment damage.

For tractors with Category 0 PTO, operate at normal Category 0 PTO speed.

26451-J

OPERATION

The designed and tested safety of this machine depends on it being operated within the limitations as explained in the manual. Be familiar with and follow all safety rules in this manual, the tractor manual and safety decals on the tractor and mower.

WARNING

■ **Do not exceed PTO speed of 1000 rpm maximum.**

The safe operation of this machine is the responsibility of the operator. The operator should be familiar with the mower and tractor and all safety practices before starting operation. Read and follow the safety rules on page 5 through page 7.

The mower is designed for lawn or grass mowing. It is not designed for rough conditions or heavy weed mowing.

It is equipped with suction type blades for best results in lawn mowing. Optional low suction blades are available for use in sandy conditions.

The warranty for this mower appears on the inside back cover of this manual. Record the model and serial numbers of your mower in the spaces provided above the warranty. Provide this information to your dealer to obtain correct repair parts.

Take all possible precautions when leaving tractor unattended: disengage PTO, lower mower, shift into neutral, set parking brake, stop engine and remove key from ignition.

DAILY CHECK LIST

- ___ Check that mower is properly and securely attached to tractor.
- ___ During inspection, check that all nuts and bolts are secure and clevis pins are properly cotter pinned.
- ___ Check condition of blades and security of attachment.

CUTTING HEIGHT ADJUSTMENT WITHOUT CASTERS

Mower cutting height is raised, lowered and maintained using tractor hydraulics and lift chains. Proper lift chain adjustment is essential. The chains must be adjusted so that tractor lift arms are in their highest position before the lift or any part of mower is within 1/4" of contacting tractor or mower lift stops. Improper lift chain adjustment could result in damage to lift mechanism or tractor.

Adjustment is accomplished by lowering lift arms and inserting lift chains into keyhole lift lugs. Raise the mower, checking to ensure it does not contact any part of tractor. Take up links, one or two at a time, until the desired height is obtained.

There is a long and short slot in the rear lift lugs. Level mower by using these slots as needed.

After setting upper lift limit, lower mower to desired cutting height. Set lower stop of mower hydraulic control lever at this point. This will allow you to raise the mower when necessary and return to the pre-set cutting height.

CUTTING HEIGHT ADJUSTMENT WITH CASTERS

The caster arm has five holes for adjustment. Cutting height is adjusted by changing the adjustment bracket hole alignment with the caster arm.

There are two holes on the frame rail to mount the caster arm. Use the rear hole for settings up to 3". Use the front hole for settings above 3".

Whenever adjustments are made to the casters, carefully raise mower to ensure casters do not come in contact with any part of tractor. Should any interference occur, readjust lift chains.

Set lower stop of tractor hydraulic control lever to prevent chains rubbing belt.

IMPORTANT

- **Be sure lift chains do not interfere with drive belt.**
- **Always raise mower off casters when backing up and turning at the same time to prevent casters from locking up on front tires.**

Attitude Adjustment

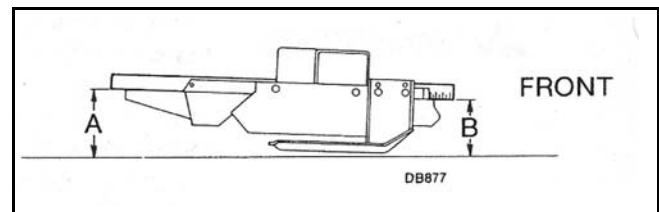

Figure 1. Attitude Adjustment

Place tractor and mower on a level surface to check and adjust mower attitude. For best mowing results, dimension "A" should not be more than 1/2" higher and never lower than dimension "B" (except when using a leaf mulcher or with some tractor tire configurations, it may be necessary to adjust rear of mower approxi-

mately 1/4" lower than front to prevent belt from rubbing on mower.)

Dimension "B" is set by adjusting optional casters or lift chains.

Dimension "A" is set by raising or lowering channel arms in push bars.

IMPORTANT

- **Any adjustment to either dimension "A" or "B" will require checking the other adjustment.**

Set desired cutting height with casters or lift chains then adjust for dimension "A".

Check attitude by placing a straight edge along outside edge of mower as shown in Figure 1. Measure from bottom of straight edge to ground. The measurement at dimension "B" should be level with or approximately 1/2" lower than the rear. The measurement at dimension "A" should never be lower than the one at dimension "B" (except when using a leaf mulcher or with some tractor tire configurations, it may be necessary to adjust rear of mower approximately 1/4" lower than front to prevent belt from rubbing on mower.)

To determine cutting height, it is necessary to subtract the distance the blade is below mower from the measurement at dimension "B". Subtract 4-7/8" from dimension "B"; the remainder is the cutting height.

Be sure mower is level side to side using these measurements. If it is not, check to be sure casters are set in same hole, and that channel arms and push bars are set in same hole on each side. Minor adjustments can be made by using slots in rear lift bracket for adjustments.

When making cutting height or attitude changes, be sure to check belt alignment. (Refer to Belt Alignment in Assembly section on page 23.)

IMPORTANT

- **Improper belt alignment or tension can cause premature belt failure.**

Side Skid Adjustment

With cutting height established, adjust side skids at least 1/2" above ground level. Properly adjusted side skids are designed to carry mower over uneven ground and minimize scalping. Never adjust side skids to be in constant contact with ground.

WARNING

- **Allow no children or unqualified persons to operate this equipment.**

- **Do not operate mower in vicinity of other persons.**

- **Do not allow riders on tractor or mower.**

PRE-OPERATION CHECK LIST

- ___ Check to ensure blades are sharp and secure and cutting edge is positioned in the direction of blade rotation (counter-clockwise as viewed from top of mower).
- ___ Always operate tractor PTO at 1000 rpm maximum when mowing.
- ___ Check to make sure all safety shielding is properly installed and is in good condition. Be sure discharge chute or side shield is installed.
- ___ Check cutting height adjustment.
- ___ Clear area to be mowed of debris that could be picked up and thrown by mower.
- ___ Place tractor transmission in neutral and be sure PTO is disengaged before attempting to start tractor engine.
- ___ Make sure all critical tractor adjustments such as brake and clutch pedal travel, etc., are set to tractor manufacturer's specifications.

STARTING & STOPPING MOWER

Power for operating the mower is supplied by tractor power take off (PTO). Refer to your tractor manual for PTO operating instruction.

WARNING

- **Do not exceed PTO speed of 1000 rpm maximum.**

CAUTION

- **Stop mower and tractor immediately upon striking an obstruction. Inspect mower and repair any damage before resuming operation.**

Should mower become plugged, causing belt to slip over two seconds, raise mower just enough to clear plug and continue running for at least two minutes, allowing pulleys to cool. Stopping the mower with belt in contact with a very hot pulley will bake and ruin belt. Do not raise mower higher than necessary, to reduce the risk of thrown objects.

Commencing Mowing

When engaging PTO, the engine rpm should always be low. Once engaged and ready to start mowing,

increase PTO speed to 1000 rpm and maintain throughout cutting operation.

During operation mowing vibration tends to loosen hardware. All hardware should be checked regularly to maintain proper torque. It is good practice to check mower before each operation to ensure all hardware is tight.

IMPORTANT

- Always raise mower off casters when backing and turning at the same time to prevent casters from locking up on front tractor tires.

MOWING TECHNIQUES

Mowing Speed

The condition of the terrain to be cut will determine the smoothness of final results. For best results, mower blades should be kept sharp at all times and the mower as level as possible. When mower blades show excessive wear, they should be replaced.

Proper ground speed for mowing will depend on the height, type and density of grass to be cut. Normally, ground speed will range from two to five mph. Tall, dense grass should be mowed at lower speeds, while thin, medium height grass can be cut at a faster ground speed.

Always operate tractor PTO at 1000 rpm maximum when mowing. This is necessary to maintain proper blade speed to produce a clean cut. Under certain seasonal conditions, front tractor tires may roll some grasses down and prevent them from being cut to the same height as the surrounding area. When this occurs, reduce the tractor ground speed, operating tractor PTO at 1000 rpm. The slower speed will permit grasses to at least partially rebound and be cut.

Under some conditions, the grasses will not rebound enough to be cut evenly, resulting in an uneven appearance. In general, lower mowing heights give a more even cut with less tendency to leave tire tracks.

Mowing Tips

Extremely tall grass should be mowed twice. Cut grass higher on first pass. Cut the second time at desired height at 90° to the first pass.

Remember, sharp blades produce cleaner cuts and use less power.

Before mowing, analyze the area to determine the best mowing procedure. Consider the height, type of grass and the terrain type (hilly, level or rough).

DANGER

- Keep away. To avoid serious injury or death from thrown objects or blade contact, never operate mower without discharge chute or side shield installed.

DANGER

- Keep hands and feet away from discharge opening.

WARNING

- Pick up all rocks, twigs and other debris before mowing. Enter new areas carefully. Cut grass higher the first time to allow mower to clear unseen objects. Never assume an area is clear. Always check!
- Clear mowing area of all people when operating mower. Thrown objects could injure bystanders.

Mow with uncut grass to the right. This will distribute the clippings over the cut area. Discharging clippings over uncut grass will cause a buildup and may prevent uniform cutting.

For a professional touch in large open areas, try the mowing pattern in Figure 2. Make two passes counter-clockwise to discharge clippings away from bordering objects. Then cut the lawn in half by mowing down the center. Turn clockwise to the right at end of area over grass previously mowed.

Plan your mowing pattern to travel straight forward whenever possible.

It is better to mow grass more often rather than too short. Short grass deteriorates rapidly in hot weather and invites weed growth during growing seasons. Follow local recommendations for the suitable cutting height in your area.

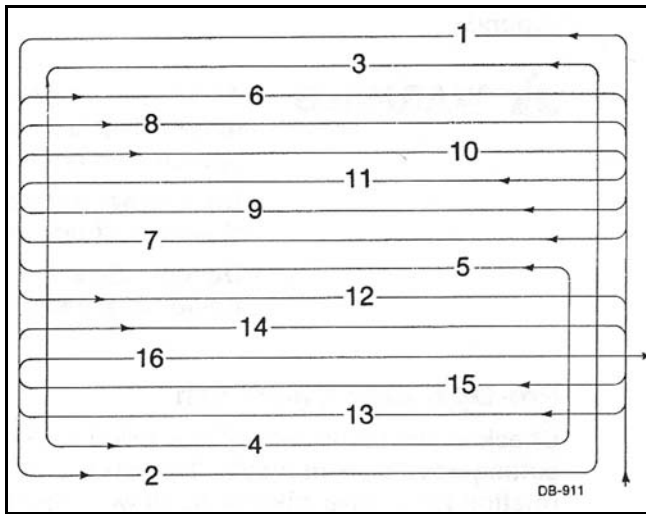

Figure 2. Mowing Pattern

BLADES

Mowers are shipped with standard suction blades which are designed for normal mowing conditions.

Optional low suction blades are available for use in sandy areas.

UNEVEN TERRAIN

⚠ WARNING

■ **Be careful when operating tractor and mower on uneven ground. In extremely uneven terrain, rear wheel weights should be used to improve traction.**

The addition of rear tire weights and liquid ballast in rear tires will increase tractor stability.

Pass diagonally through sharp dips and avoid sharp drops to prevent “hanging up” the tractor and mower. Practice will improve your skills in maneuvering rough terrain.

Avoid sudden starts and stops when traveling up or down hill. Always mow down steep slopes, never up or across the face.

Slow down on sharp turns and slopes to prevent tipping or loss of control.

CLEANING

After Each Use

- Remove large debris such as clumps of dirt, grass, crop residue, etc. from machine.
- Inspect machine and replace worn or damaged parts.
- Replace any safety decals that are missing or not readable.

Periodically or Before Extended Storage

- Clean large debris such as clumps of dirt, grass, crop residue, etc. from machine.
- Remove the remainder using a low-pressure water spray.
 1. Be careful when spraying near scratched or torn safety decals or near edges of decals as water spray can peel decal off surface.
 2. Be careful when spraying near chipped or scratched paint as water spray can lift paint.
 3. If a pressure washer is used, follow the advice of the pressure washer manufacturer.
- Inspect machine and replace worn or damaged parts.
- Sand down scratches and the edges of areas of missing paint and coat with Woods spray paint of matching color (purchase from your Woods dealer).
- Replace any safety decals that are missing or not readable (supplied free by your Woods dealer). See Safety Decals section for location drawing.

OWNER SERVICE

WARNING

■ Lower mower to ground, turn tractor engine off and remove key before performing any maintenance.

■ When completing a maintenance or service function, make sure all safety shields are in good condition and properly installed before placing mower in service.

CAUTION

■ Always use personal protection devices such as eye and ear protectors when performing maintenance functions.

BELT INSTALLATION

See Belt Installation in Assembly section on page 19.

BLADE SERVICING

Blades may be removed from the mower while it is still mounted on the tractor.

WARNING

■ If you suspend mower on tractor hydraulic system, be sure to install safety blocks. The tractor hydraulic system could fail, causing mower to fall and crush anything under it.

■ Do not handle mower blades with bare hands. Careless or improper handling may result in serious injury.

Inspect blades before each use to determine that they are mounted tightly and are in good condition. Replace any blade that is bent, excessively nicked, worn or has any other damage. Small nicks can be ground out when sharpening.

BLADE REMOVAL

See Figure 3. Install blade wrench over spindle pulley bolts to prevent spindle from rotating while removing bolt (10) which has left hand threads. Then remove special washer (9), sleeve (8), cup washers (7), shim

washer (6), blade (5), blade stop (4) and clutch disc (3). Shoulder washer (2) will not normally come off machine unless intentionally removed.

BLADE INSTALLATION

See Figure 3. Assemble shoulder washer (2) small end up (if removed). Install remaining parts in reverse order of disassembly. Ensure blade cutting edge is positioned to lead in counter-clockwise rotation, as viewed from top of mower.

Shims should be added to blade installation to leave approximately 1/32" cup in cup washers when blade bolt is torqued to 170 lbs-ft.

Excessive blade slipping can cause the cup washers to burn and lose their clamping force. If this happens, the cup washers must be replaced.

This blade friction clutch disc allows the assembly to slip when hitting a solid object. If slippage occurs during normal mowing, it may be necessary to add an additional shim washer (6).

WARNING

■ Do not substitute any bolt for the special blade bolt. It is self-locking, meeting the non-loosening requirements for this application.

■ Your dealer can supply Woods replacement blades. They are made of special steel alloys and subjected to rigid heat-treated and inspections requirements. Substitute blades may not meet these rigid specifications and may be dangerous.

BLADE SHARPENING

IMPORTANT

■ When sharpening blades be sure to balance them. Unbalanced blades will cause excessive vibration which can damage blade spindle bearings. Vibration may also cause structural cracks in mowing housing.

See Figure 4. Follow original sharpening pattern as shown in Figure 4. Do not sharpen blade to a razor edge, but leave a 1/32" to 1/16" blunt edge. Do not sharpen back side of blade.

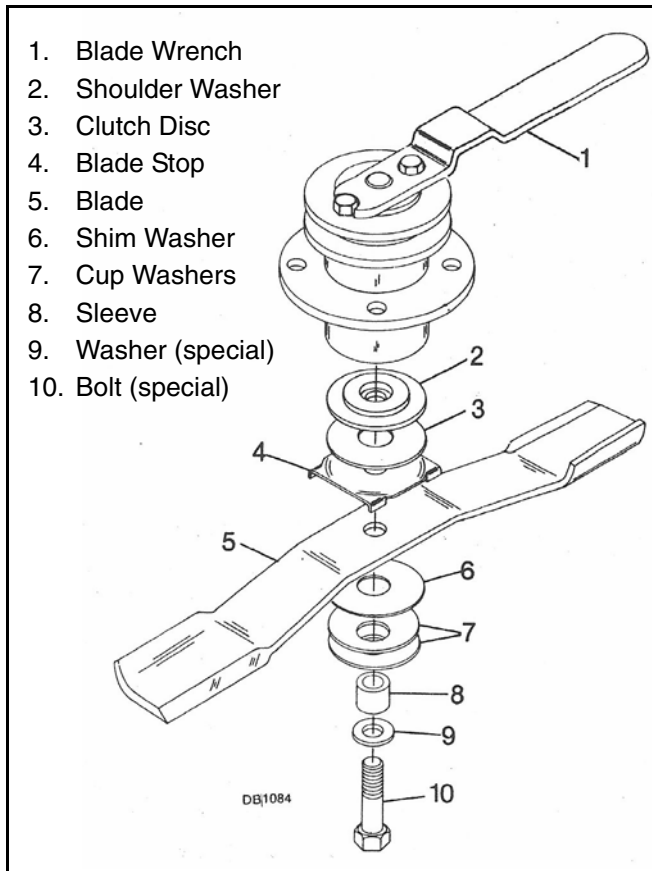

Figure 3. Blade Assembly

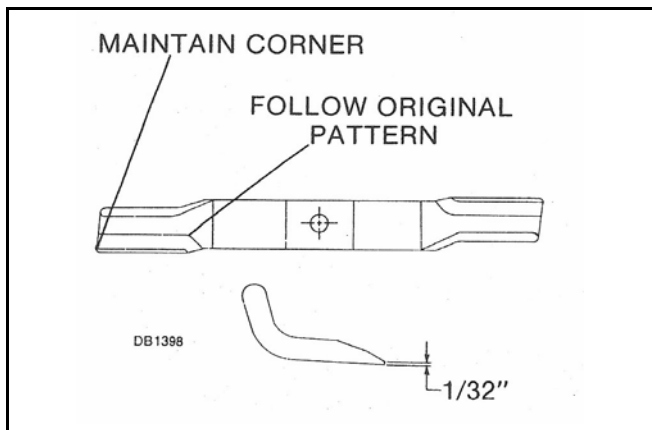

Figure 4. Blade Sharpening

LUBRICATION

⚠ CAUTION

■ **Always wear safety glasses and ear protection when performing service or maintenance functions that could cause injury to eyes or ears.**

See Figure 5 and Figure 6. Be familiar with and follow all safety rules and decals.

⚠ WARNING

■ **Lower mower to ground, shut off tractor engine and remove key before servicing.**

Do not let excess grease collect on or around parts, particularly when operating in sandy areas. The accompanying illustrations give the lubrication points and frequency. The hours are based on normal operating conditions. Severe or unusual conditions may require more frequent lubrication.

Use a SAE multi-purpose type grease for all locations shown. Be sure to clean fitting thoroughly before using grease gun.

IMPORTANT

■ **Do not over grease blade spindles. Excess grease could be transferred to the belt and cause slippage and premature failure.**

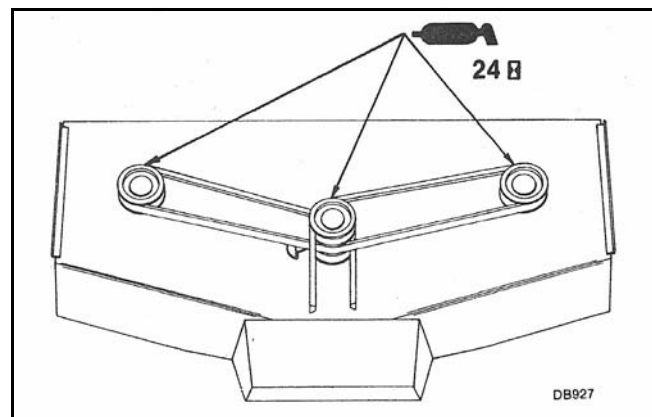

Figure 5. Spindle Lubrication

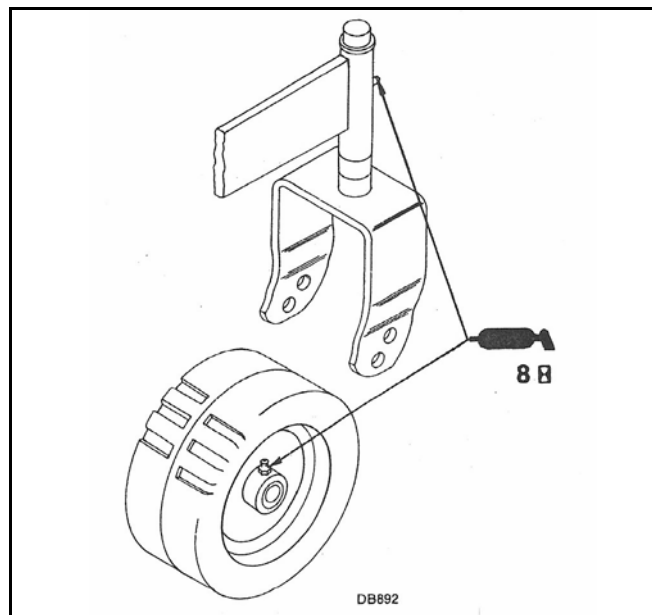

Figure 6. Caster Lubrication

DEALER SERVICE

⚠ WARNING

■ Lower mower to ground, turn tractor engine off and remove ignition key before performing any maintenance.

■ When completing a maintenance or service function, make sure all safety shields are in good condition and installed before placing mower in service.

⚠ CAUTION

■ Always use personal protection devices such as eye and ear protection when performing maintenance functions.

The information in this section is written for dealer service personnel. The repair described herein requires special skills and tools. If your shop is not properly equipped or your mechanics are not properly trained in this type of repair, you may be time and money ahead to replace complete assemblies.

SPINDLE INSPECTION

Spindles are equipped with two tapered roller bearings. Adjustment is set by pressing a sleeve on the shaft until all end play is removed. Adjustment is maintained with a roll pin driven through the sleeve and shaft.

Periodically inspect blade spindles by grasping pulley, moving from side to side and up and down. Also rotate spindle. If end play or wobble is detected or if it feels rough when rotated (indicating bad bearings), repair or replace.

REMOVING SPINDLE FROM MOWER

Remove blade from spindle. Refer to Blade Removal on page 12.

Remove belt shield and remove belt.

Disassemble split taper bushing (located on top of pulley) by removing the two bolts and inserting them into threaded holes. Tighten alternately to remove split taper bushing.

Remove key and pulley.

Remove four spindle attaching bolts and remove spindle.

SPINDLE REPAIR

Permatex 3D Aviation Form-A-Gasket[®], or equivalent, is recommended as a sealant.

For reference, the short cup chamber is on top.

Cups and cones are a press fit to minimize wear.

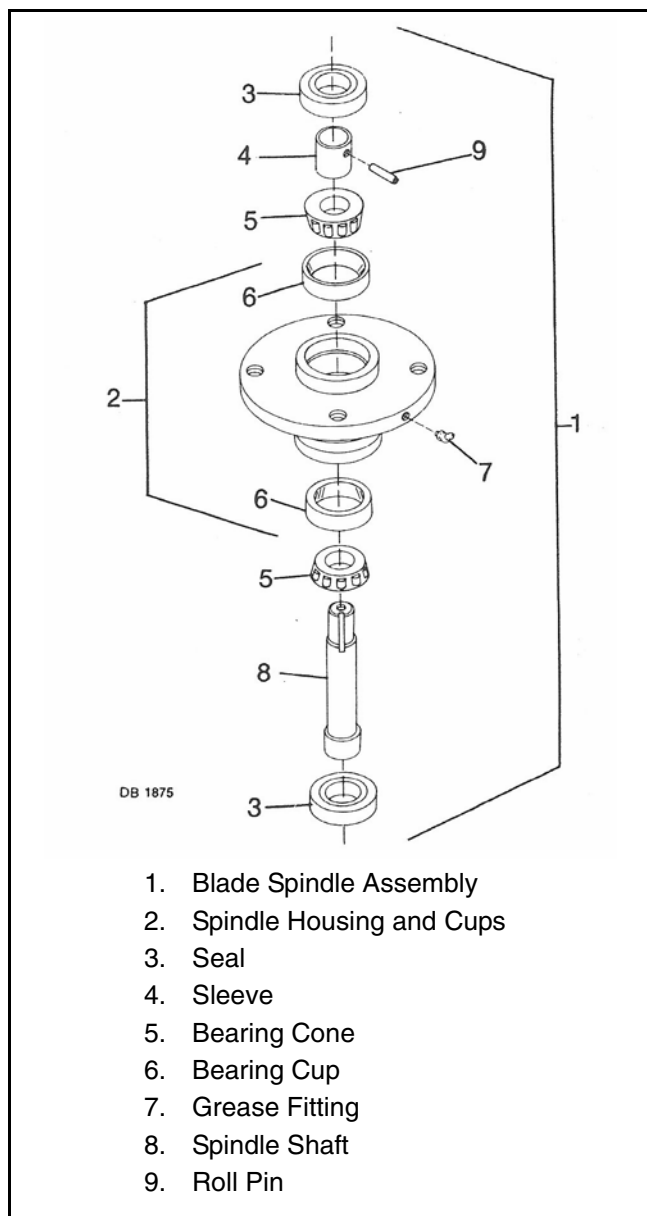

Figure 7. Spindle Repair

Disassembly

Drive roll pin out of sleeve and shaft.

Place spindle assembly in a press and press shaft down through housing.

Remove seals from housing.

Remove bearing cups from housing by placing a punch in slots provided and drive out. Alternate punch position from side to side. Take care to prevent housing damage.

Assembly

Bearing cones and cups are designed to mate. It is important to position them so bearing cones taper mates with cup taper.

Lubricate new cups with a light oil. Place them in spindle housing with tapers toward the outside.

Seat cups securely with a press or place a large soft drift on the flat lip of cup and drive them into housing until seated against machined shoulder of housing.

Polish areas of shaft and sleeve where seals will seat with emery cloth.

Place bottom bearing cone on spindle shaft so it will mate with cup, and press on until it seats on bottom shoulder of shaft.

Insert shaft and bearing through bottom of housing and seat against cup.

Fill housing cavity with a medium grade grease.

Install top bearing on shaft to mate with top cone and press on shaft until there is room for sleeve.

Apply a thin coat of Permatex to shaft area where sleeve will seat. Install sleeve on shaft and press sleeve and bearing down shaft until all end play is removed (similar to adjusting front wheel bearings on an automobile). Check by spinning spindle. It should turn freely. If it is too tight, hold spindle housing and hit spindle shaft with a lead hammer. Press again until the proper adjustment is obtained.

Be careful not to over-tighten bearings. Proper bearing adjustment is essential to good bearing life.

IMPORTANT

■ **Improper positioning of seals can cause seal and spindle damage.**

Proper seal installation is important. An improperly installed seal will leak and could cause bearing failure.

Pull the rubber portion of seal back and locate spring.

Lightly coat area of housing where seals seat with Permatex.

Install bottom seal with spring up toward center of housing.

Place seal squarely on housing and select pipe or tubing with an OD that will set on outside edge of seal. A tubing with an OD that is too small will bow seal cage.

Carefully guide seal lip over shaft and carefully press seal into housing. Be careful to prevent distortion to metal cage. Seal should seat firmly and squarely against machined shoulder in housing.

Make sure seal lip did not roll under. Distortion to seal case or damage to seal lip will cause seal to leak. Damaged seals must be replaced.

Carefully press top seal into housing with spring up and away from center of housing. Top seal should be flush with up to 1/16" above housing.

Drill a 3/16" hole 9/32" down from top of sleeve and drive roll pin through sleeve and shaft to hold bearing adjustment.

Lubricate spindle with a medium grade grease. Turn spindle bottom up and vent bottom seal with a dull instrument such as a tongue depressor or letter opener.

Apply grease until it comes out where you are venting seal. Use care to prevent cutting or nicking seal.

Rotate spindle housing on shaft, checking for free movement.

Spindle Installation

Insert spindle up through bottom of mower frame. Position grease fitting for proper lubrication access and install the four mounting bolts.

PULLEY INSTALLATION

Install pulley onto spindle shaft. Install split taper bushing and key. Alternately tighten bolts to 12 lbs-ft. Check to be sure pulley is located on shaft to the dimensions shown in Figure 8. Dimensions are from top of mower frame to pulley center line.

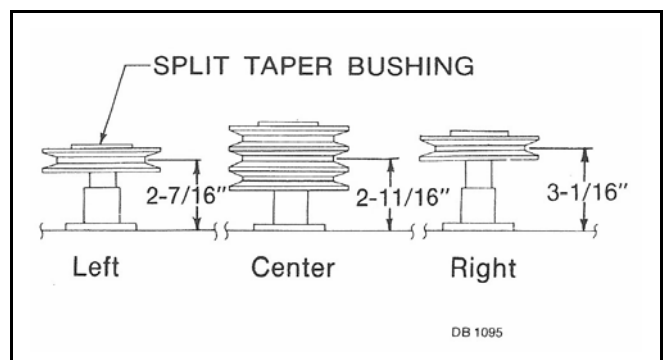

Figure 8. Pulley Installation

TROUBLE SHOOTING BELT CONDITIONS

PROBLEM	POSSIBLE CLAUSE	SOLUTION
Belt slippage	Belt too loose	Adjust tension.
	Mower overloading, material too tall or heavy	Reduce tractor ground speed but operate PTO at 1000 rpm. Cut material twice, one high pass and then mow at desired height. Cut a partial swath.
	Oil on belt from over lubrication	Be careful not to over lubricate. Clean lubricant from belt and pulley with clean rag. Replace oil soaked belt.
	Belt hung up or rubbing	Check belt for free travel in pulleys and belt guides. Check under mower and around blade spindle shafts for wire, rags or other foreign material. Clean all material from under mower.
	Belt or pulleys worn out	If the belt rides in bottom of pulley groove, either belt or pulley is worn and must be replaced.
Frayed edges on cover	Belt misaligned or belt rubbing guide	Re-align belt or guide. Be sure belt doesn't rub any other part while running.
Belt rollover	Misaligned rear drive pulley	Re-align drive pulley.*
	Damaged belt	Replace belt.*
	Foreign object in pulley grooves	Inspect all pulley grooves for rust, paint or weld spots and remove.
	Worn pulley groove	Replace pulley.
Damaged belt	Rollover, high shock loads or installation damage	Replace belt.*
Belt breakage	High shock loads	Raise cutting height. Avoid abusive mowing. Avoid hitting the ground or large obstructions.
	Belt came off drive	Check drive alignment for foreign material in grooves. Avoid hitting solid objects or ground.

* Check belt for damage by laying it flat on floor. If belt does not lie flat (has humps or twists), which indicates broken or stretched cords, it must be replaced.

TROUBLE SHOOTING MOWING CONDITIONS

PROBLEM	POSSIBLE CAUSE	SOLUTION
Grass cut higher in center of swath than at edge	Height of mower higher at rear than at front	Check cutting height adjustment.
	Loose blade	Check clamping cup washers. If flat or not holding, replace.
Grass cut lower in center of swath than at edge	Height of mower lower at rear than at front	Adjust mower height and attitude so that mower rear and front are within 1/2" of same height.
	Loose blade	Check clamping cup washers. If flat or not holding, replace.
Streaking conditions in swath	Conditions too wet for mowing, blades unable to cut that part of grass pressed down by path of tractor tires	Allow grass to dry before mowing. Slow ground speed of tractor but keep PTO running at 1000 rpm. Cutting lower will help. Under some conditions it is impossible to pick up and cut grass pressed down by tires.
	Dull blades	Sharpen or replace blades.
	Loose blades	Check clamping cup washers. If flat or not holding, replace.
Material discharges from mower unevenly, bunches of material along swath	Material too high or too much material	Reduce ground speed but operate tractor PTO at 1000 rpm maximum, or make two passes over material. Raise mower for first pass. Lower to desired height for second and cut at 90° to first pass. Raise rear of mower high enough to permit material to discharge, but not so high that conditions above occur.
	Grass wet	Allow grass to dry before mowing. Slow ground speed of tractor but keep PTO running at 1000 rpm. Cutting lower will help.
	Clippings packed to underside of mower	Remove clippings and clean underside of mower.
Erratic mower operation or mower slows down without tractor engine slowing	Belt slippage	See belt trouble shooting.
Scalping	Mowing too slow	Raise cutting height.
	Skids too high	Adjust skids. Install front roller.

ASSEMBLY

DEALER SET-UP INSTRUCTIONS

Assembly of this mower is the responsibility of the Woods dealer. The mower should be delivered to the owner completely assembled, lubricated and adjusted for normal cutting conditions.

Using these instructions, set up mower as received from the factory.

Complete check lists on page 27 when set-up is complete.

The mower is shipped partially assembled. Assembly will be easier if components are aligned and loosely assembled before tightening hardware. Recommended torque values for hardware are located on page 35.

Select a suitable working area. Open parts boxes and lay out parts and hardware to make locating easy. Refer to illustrations, accompanying text, parts lists and exploded view drawings.

CAUTION

■ Always use personal protection devices such as eye and ear protectors during assembly.

MOWER PREPARATION

DANGER

■ Keep away. To avoid serious injury or death from thrown objects or blade contact, never operate mower without discharge chute in place.

Side Skid Installation

Attach side skids to outer frame rail with 1/2 x 1-1/4" bolts. Final adjustment of skids will be necessary when cutting height is established.

Side Shield or Discharge Chute Installation

Attach side shields to right and left side of mower. Install baffled shield on left side. The discharge chute may be installed on left side to replace left shield when mowing in heavy material.

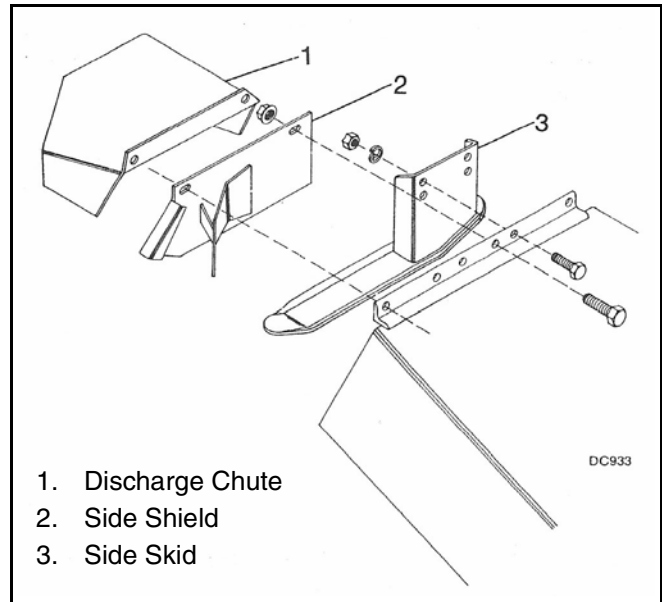

Figure 9. Discharge Chute, Side Shield & Side Skid Installation

Crosswise Support Installation

Attach crosswise support to mower deck, welded lug forward. The lug has two holes. Use bottom holes for low cutting heights and top holes for higher cutting heights. Install spacer bushing into appropriate hole. Insert bolt through deck and slide crosswise support onto bolt. Secure with nut.

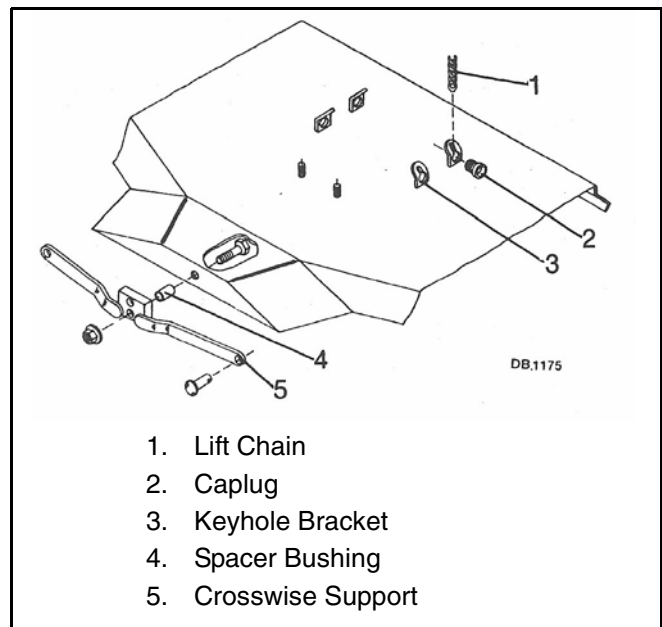

Figure 10. Crosswise Support Installation

Push Channel Installation

Refer to Front Mounting Assembly parts list on page 30. Pin push channels (44) to mower frame as shown

with 5/8 x 1-1/2" clevis pins and secure with safety pins. Attach channels to crosswise support with clevis pins and secure with safety pins.

Lift Chain Installation

See Figure 10. Lift chains are inserted in keyhole brackets on mower deck and secured with caplugs.

There are two sets of three keyhole brackets. Use the front outside brackets.

Belt Take-Up Assembly

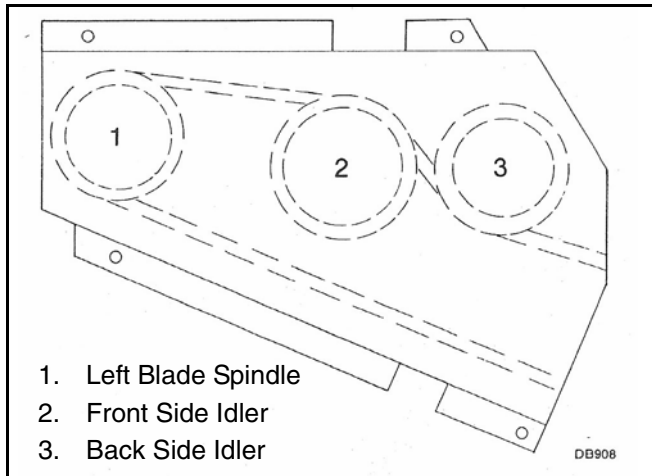

Figure 11. Belt Take-Up Assembly

Belt Installation on Mower

CAUTION

■ Wear gloves when installing belt. Be careful to prevent your fingers from being caught between belt and pulley.

One of the major causes of belt failure is improper installation. Before you install a new belt, check pulley shafts and bearings for wear. Check pulley grooves for cleanliness and be sure pulleys turn freely and with only slight wobble. If grooves require cleaning, moisten a cloth with a non-flammable, non-toxic, degreasing agent or commercial detergent and water.

Avoid excessive force during installation. Do not use tools to pry belt into pulley groove. Do not roll belt over pulleys to install. This can cause hidden damage and premature belt failure. Always loosen idler pulleys prior to belt installation.

The belt may be completely installed with mower mounted on tractor. However, it is easier to install belt on mower frame with mower detached.

Be sure belt clears belt guides by 1/8". Reform guide if necessary. This should be checked with belt completely installed.

Step 1: Insert belt in bottom right hand groove of center pulley and route toward take-up assembly. Tip take-up assembly forward and route belt through idler pulleys as shown in Figure 12.

The belt take-up assembly replaces left belt shield. To install, remove left belt shield and replace with take-up assembly. Do not tighten hardware until belt is installed.

Step 2: Route belt back to center pulley and insert in middle groove, then route around right pulley.

Step 3: Route belt to center pulley, insert in top groove and pull to rear. Belt installation will be completed when mower is installed on tractor.

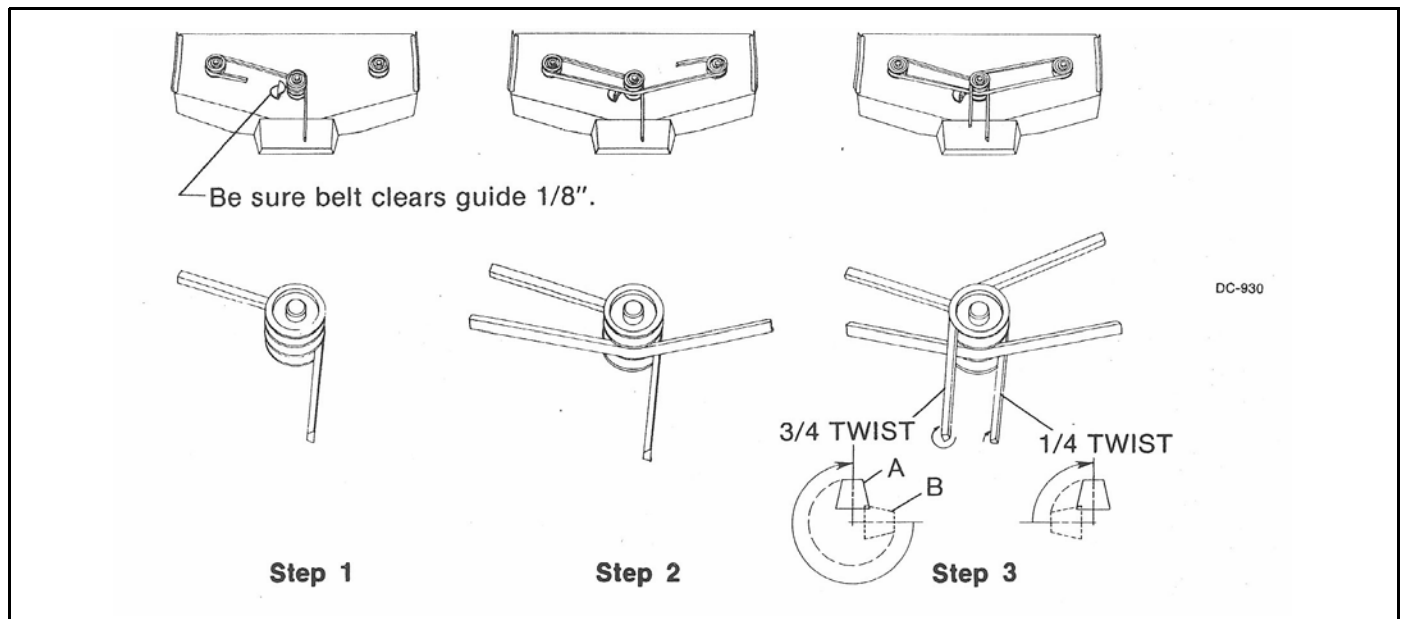

Figure 12. Belt Installation

TRACTOR PREPARATION

Remove lower 3-point lift arms, connecting links, drawbar and sway chains from tractor.

On tractors equipped with draft control, replace draft control top link bracket with Kubota right and left top link holders, part #99571-2214-0 and #99571-2215-0.

Rear Tractor Tire Adjustment

Adjust rear tires to provide spacing between tires as given in chart.

Tire Type	Tire Size	TRACTOR MODEL		
		2250	2550	2850
TURF	13.6-16	31.5	31.5	---
	355/80D20	31.5	31.5	30.25
AG	9.5-24	35.5	---	---
	11.2-24	36.6	36.6	---
	12.4-24	---	35.75	32.75
	13.6-24	---	---	36.0

Idler Bracket Installation

See Figure 13. Position idler bracket under tractor housing and attach using bolt and lock washer removed from tractor drawbar. Place a 5/8" flat washer from mower parts package on each bolt. Insert bolt through bracket and place a 5/8" flat washer on each bolt. Use two bolts and lock washers removed from tractor PTO shield and place a 1/2" flat washer over each bolt. Use this hardware to secure rear of idler bracket to tractor.

Insert carriage bolt (14) through right slot of idler bracket as shown in Figure 13. Install a washer (10), belt guide (13), two washers (10), pulley, lock washer (11) and nut (12) on bolt.

Insert carriage bolt (14) through left slot of idler bracket as shown in Figure 13. Install three washers (10), pulley, lock washer (11) and nut (12).

Do not tighten nuts on idlers at this time.

Place right rear left angle (16) over square tube as shown and clamp in place using clamp (7), bolts (9) and nuts (2). Install left rear lift angle (3) in same manner.

Install chain idler (8) in each lift angle with clevis pin (6) and cotter pin (4).

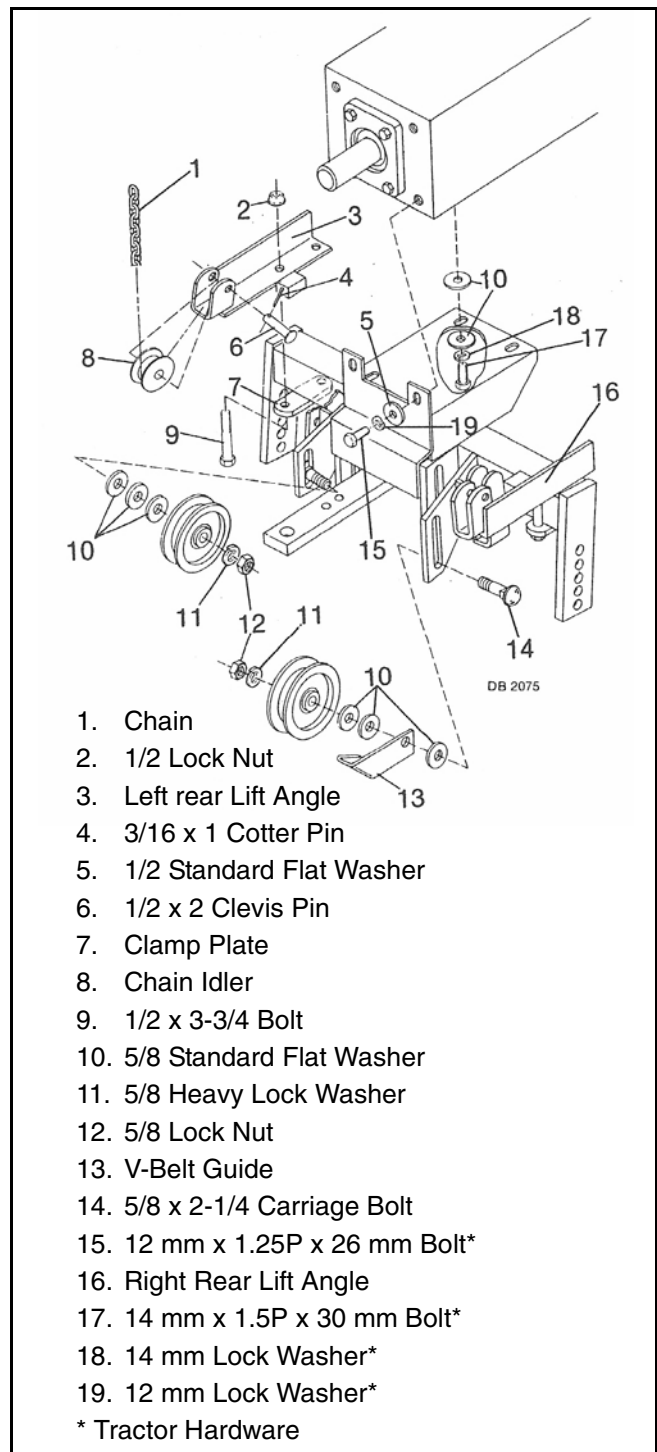
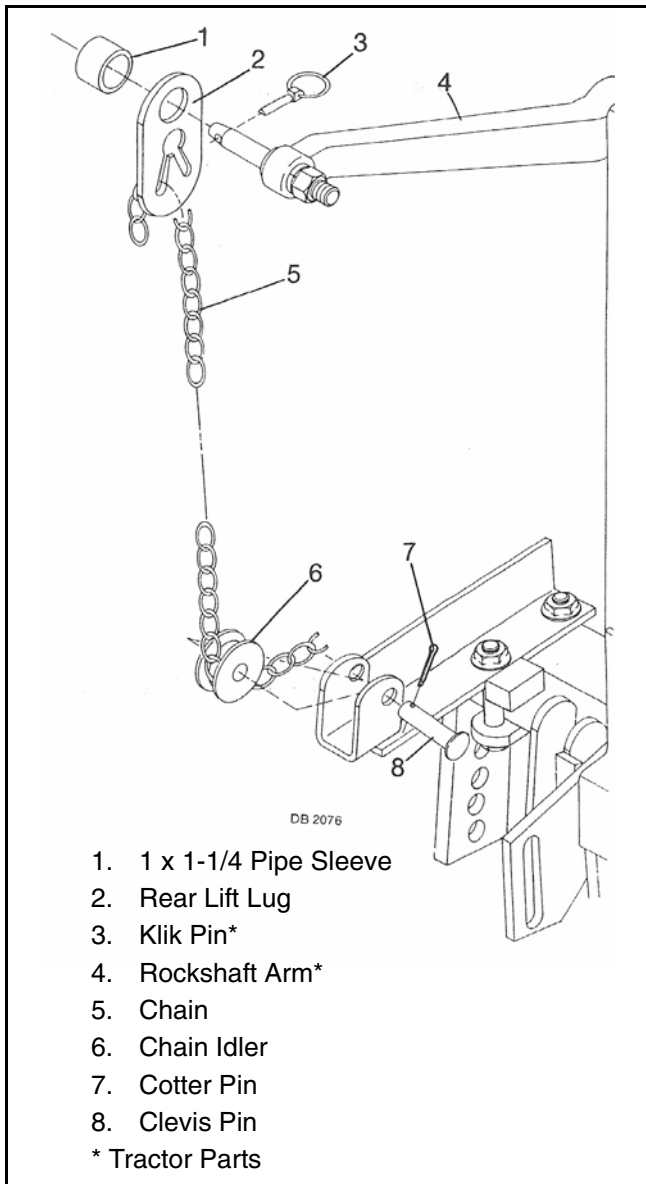

Figure 13. Idler Bracket Installation

Rear Lift Installation

See Figure 14. Install lift lug (2) over rockshaft pin, slide pipe sleeve over pin, and secure with Klik pin (3). Repeat for opposite side.



1. 1 x 1-1/4 Pipe Sleeve
 2. Rear Lift Lug
 3. Klik Pin*
 4. Rockshaft Arm*
 5. Chain
 6. Chain Idler
 7. Cotter Pin
 8. Clevis Pin
- * Tractor Parts

Figure 14. Rear Lift Installation

Drive Pulley Installation

See Figure 15. Remove paint from center hole of drive pulley. Insert split taper bushing and square key into drive pulley.

Start bolts into bushing but do not tighten.

Slide pulley and bushing onto tractor PTO shaft. On **L2250** and **2550** tractors, the bushing will overhang the PTO shaft approximately 3/8".

On **L2850** tractors, the PTO shaft will protrude through bushing approximately 15/16".

Do not tighten assembly; belt must be aligned first.

Drive Pulley Alignment

Align drive pulley with idler pulleys and check with a straight edge. Alternately tighten bolts on split taper bushing to secure drive pulley in proper alignment.

Continue to alternate tightening sequence until assembly is tight and all bolts are torqued to 12 lbs-ft. Recheck drive pulley to idler pulley alignment.

IMPORTANT

■ **Be sure to torque bolts to exactly 12 lbs-ft. Do not overtighten or pulley casting may crack.**

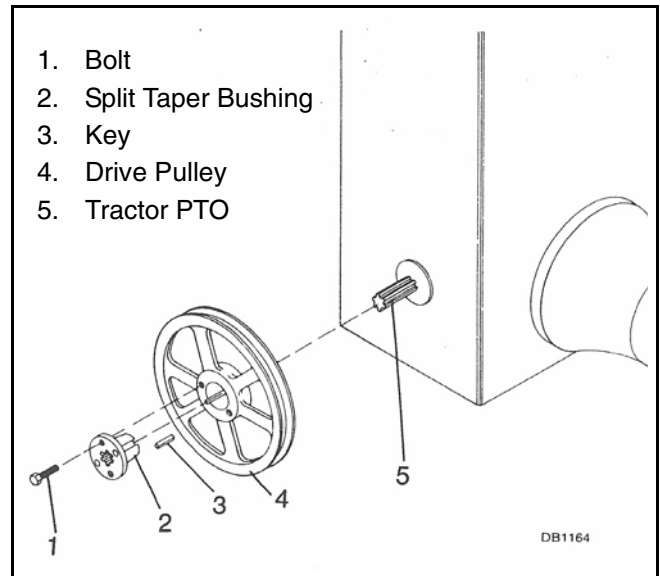

Figure 15. Drive Pulley Installation

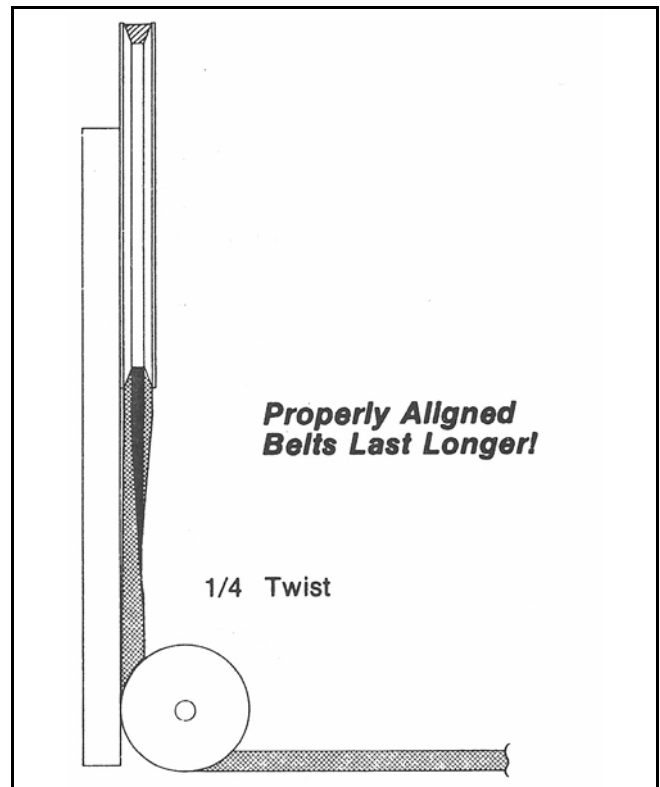

Figure 16. Drive Pulley Alignment

Front Lift Bracket Installation

See Figure 17 and Figure 18. Right and left front lift brackets, when properly installed, will tip slightly to the

rear. Place clevis portion of bracket inward and install chain idler in rear hole of bracket clevis.

Install brackets to tractor as shown in Figure 17. There is a plate bolted over clutch housing. When installing right bracket, remove two bottom bolts attaching this plate to tractor. There is a bolt just above these bolts. Remove it. Remove washer and reinstall bolt. Be sure to use the 14 mm bolts provided in mower kit for bracket installation. Place heavy duty lock washer over each bolt.

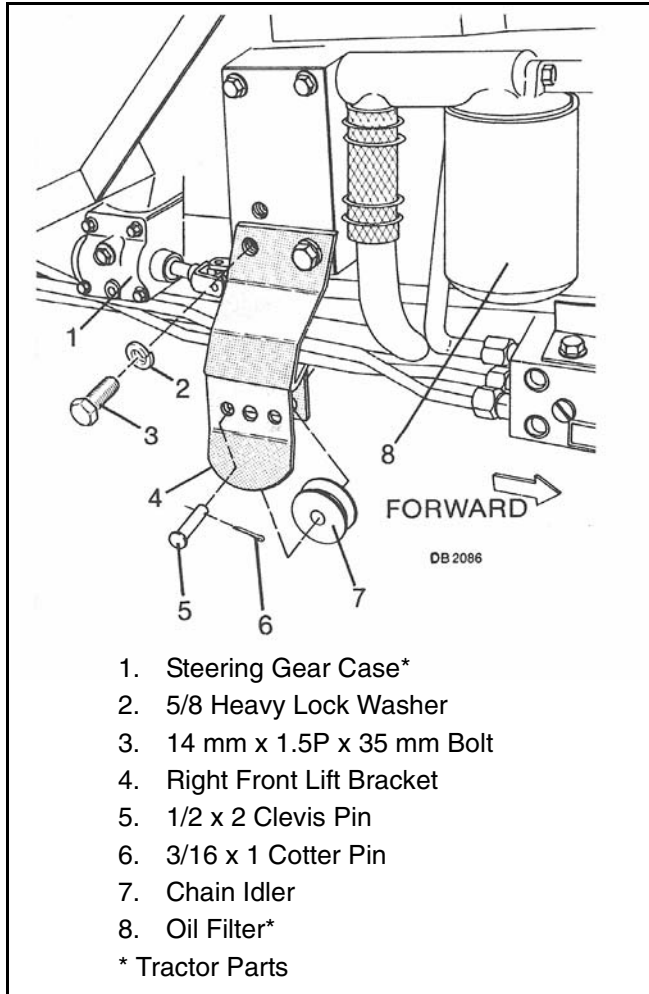

Figure 17. Right Front Lift Bracket Installation

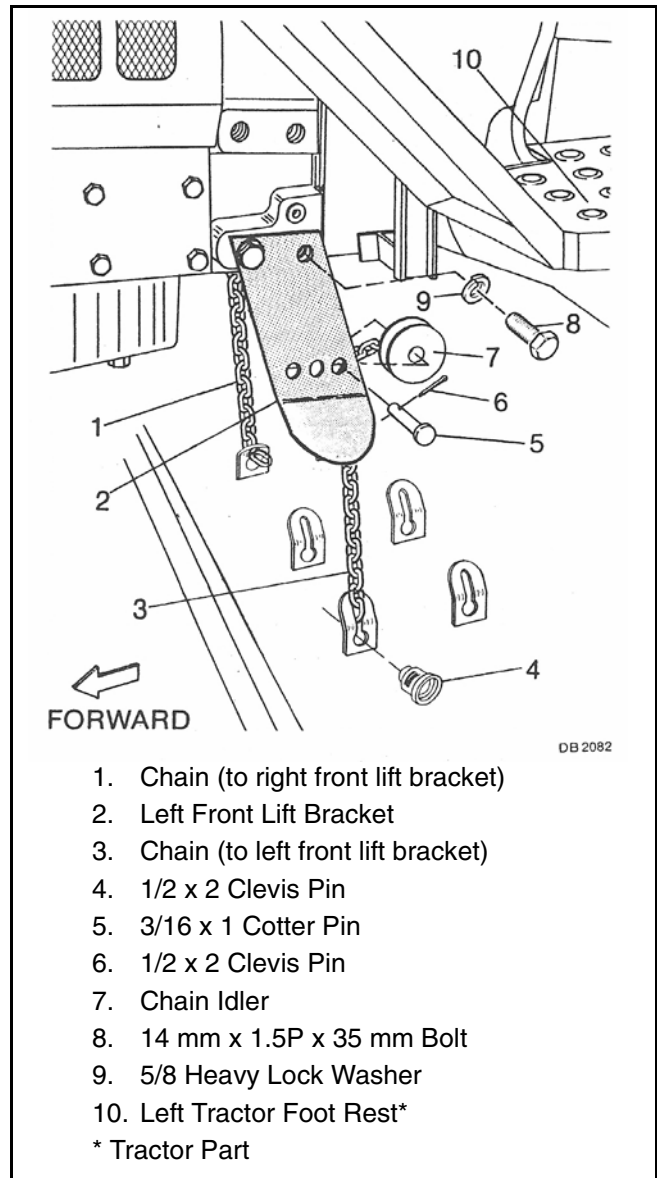

Figure 18. Left Front Lift Bracket Installation

ATTACHING MOWER TO TRACTOR

Position mower under tractor. It will be necessary to lift front wheels off ground.

⚠ CAUTION

■ **Use care when moving mower under tractor. Do not get under tractor. Be sure lifting device is safe.**

If a lifting device is not available, the mower frame is strong enough to back the tractor over mower. Use care to prevent damage to painted surface when using this method.

Place a wooden block behind each rear tire to act as a ramp. Do not spin tires against mower frame. Back on then drive off.

Push Channel Attachment

Select desired cutting height (refer to Operation section), and attach push channel arms to idler bracket with 5/8 x 1-3/4 clevis pins (installed from outside in) and secure with safety pins.

Belt Installation

Pull belt to rear of tractor. Give belt a 3/4 clockwise twist between center pulley and left idler. Install belt under idler and route over drive pulley. A 1/4 clockwise twist should occur between right idler and center pulley. If any twist occurs other than these, the belt is incorrectly installed. Recheck installation steps and correct as necessary.

Lift Chain Installation

Straighten lift chains so links are flat (without twist) and thread through front lift bracket chain idlers mounted directly above mower frame.

Route chain under tractor and through rear chain idlers mounted on idler bracket. Make sure chain remains flat. A twisted chain will not roll smoothly through chain idler. Insert end of chain into rear lift lugs mounted on tractor rockshaft arms. When cutting height is adjusted and installation complete, cut off excess chain leaving over 4".

Adjust cutting height (refer to Operation section, page 8).

Belt Alignment

See Figure 19 through Figure 24. Belt alignment and tension should be set at the same time. It is suggested that you read both the Alignment and Tensioning sections on page 23 before attempting either. Improper tension or alignment will affect belt life.

With mower level and cutting height set, check belt alignment.

Belt alignment is accomplished by adjusting idler pulleys and/or moving the mower forward or to the rear with push channel adjustment.

Alignment tolerances are shown in Figure 19 through Figure 24. The best idler alignment is shown in Figure 19 and Figure 22. However, it is not always possible to achieve. Alignment may be set within the tolerances given but the left idler must always be at least 1" higher than the right.

Be sure belt does not rub on rear apron of mower. If mower is set to high cutting heights, it is sometimes necessary to run back of mower 1/4" lower than front to prevent this.

IMPORTANT

- Belt must not rub deck or crosswise support.

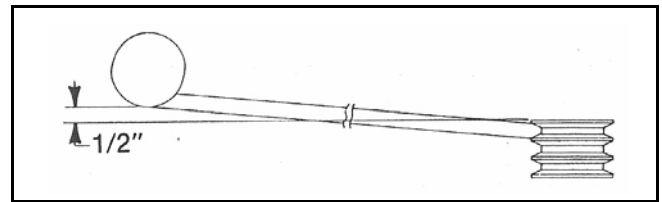

Figure 19. Best Possible Alignment of Left Idler

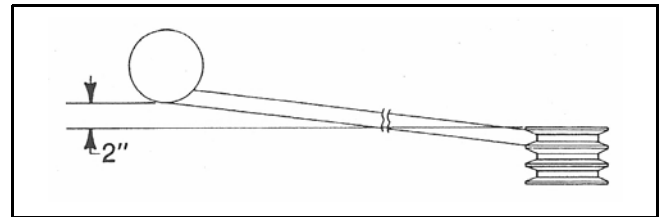

Figure 20. Maximum Left Idler Should be Raised

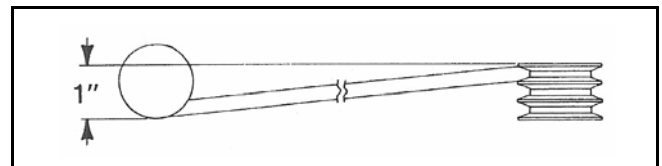

Figure 21. Maximum Left Idler Should be Lowered

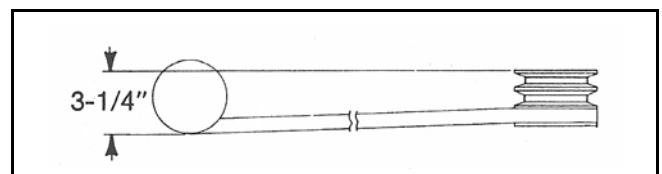

Figure 22. Best Possible Alignment of Right Idler

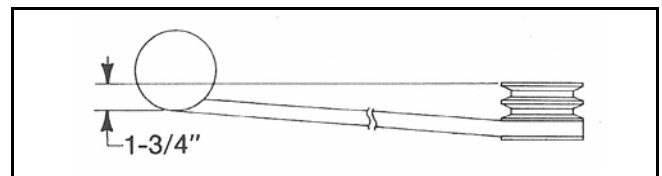

Figure 23. Maximum Right Idler Should be Raised

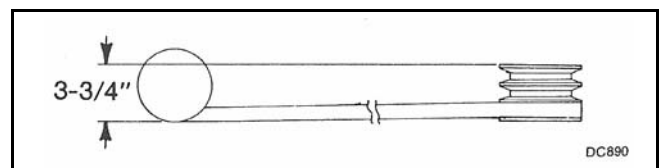

Figure 24. Maximum Right Idler Should be Lowered

Belt Tension

Set belt tension using a spring scale or other force measuring device. Remove right belt shield and attach scale between the center and right pulley. Apply between three and four pounds of force. Belt deflection should measure 5/16" for normal conditions.

Tension may be increased if necessary to prevent belt from slipping in heavy mowing conditions.

When checking tension without a force measuring device, the belt, when properly set, should feel very tight.

Cycle belt through at least two revolutions after any adjustment before checking tension. These belts are very strong and need to be adjusted very tightly. Belts are more likely to be damaged by excessive slippage than from being overtightened.

Minor tension adjustments are made by moving the idler pulleys up or down. Major tension adjustments are made by moving the mower deck forward and rearward.

IMPORTANT

■ **Alignment must be rechecked if it is necessary to move idler pulleys or the mower deck to get proper belt tension.**

■ **Tension on a new belt should be readjusted every half hour for the first two hours and then checked every eight hours of operation.**

Rear Belt Shield Installation

Place stud welded on bottom of belt shield in small front hole of idler bracket drawbar.

Install clevis pin through belt shield brackets and top link bracket.

Secure with safety pin.

OPTIONAL EQUIPMENT

A leaf mulcher, low suction blades, extra-suction blades, front roller and casters are offered as optional equipment for this mower. Some options may not be available for some mountings.

Blades

Low suction and extra suction blades are optional for this mower. In sandy areas where abrasive action could cause excessive blade wear, low suction blades are recommended.

Extra suction blades are designed to lift up fragile downed grasses for better cutting results. They are also recommended for use with leaf mulcher attachment.

Casters

Casters are used to adjust cutting height.

Mount casters on mowers to the outside deck rails and over side shield or discharge chute. Attach rear of caster arm in fourth hole from front of deck rail with a 3/8" x 1-1/2" bolt and secure with lock washer and nut. The arm may be mounted in the third hole to obtain more height and caster adjustment.

Attach the right and left adjustment brackets, offset down and inward, and in front hole as shown in Figure 25 on each side of the deck angle and inside side skid. Use two 1/2" flat washers as spacers at the rear side skid hole.

Select the desired cutting height and install adjustment brackets to caster arm with 1/2" x 1-3/4" bolts and secure with 1/2" flange lock nuts.

Adjust side skids to ride at least 1/2" above ground level.

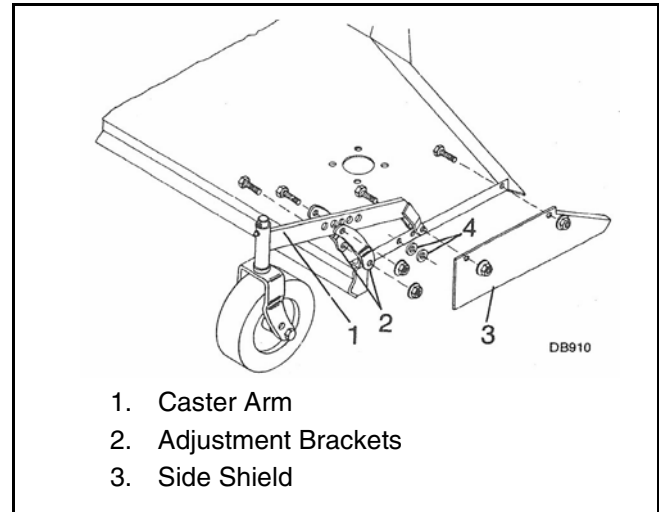

Figure 25. Caster Assembly

Front Roller

The front roller should be used when scalping occurs. Side skids and casters effectively reduce scalping in most cases. You may encounter areas where the side skids or casters will drop into depressions and allow the center of the mower to contact the ground and scalp. When this occurs you should install a front roller in the center of the mower.

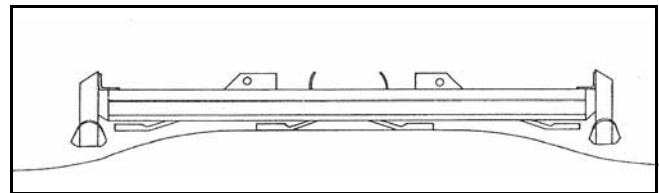

Figure 26. Scalping Without Front Rollers

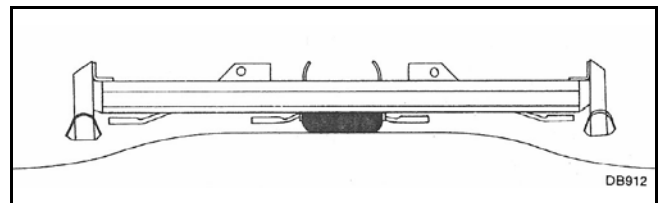

Figure 27. Front Rollers Reduce Scalping

See Figure 28. Place and secure mower in vertical position to make front roller installation easier.

Four holes for mounting the front roller are provided in the front center mower deck.

Mount the left and right roller brackets in these holes. The hole pattern for the roller brackets determines which bracket is used for right and/or left.

The left roller bracket angle should be installed so highest hole is to the front with bracket angle extending left, item 3). See Figure 28.

Install right roller bracket with 3/8" x 1" carriage bolts and flange lock nuts.

Insert rod through roller and install into the rear roller bracket holes. Secure each end of the rod with a 3/16" cotter pin. Turn roller by hand to ensure it rolls freely.

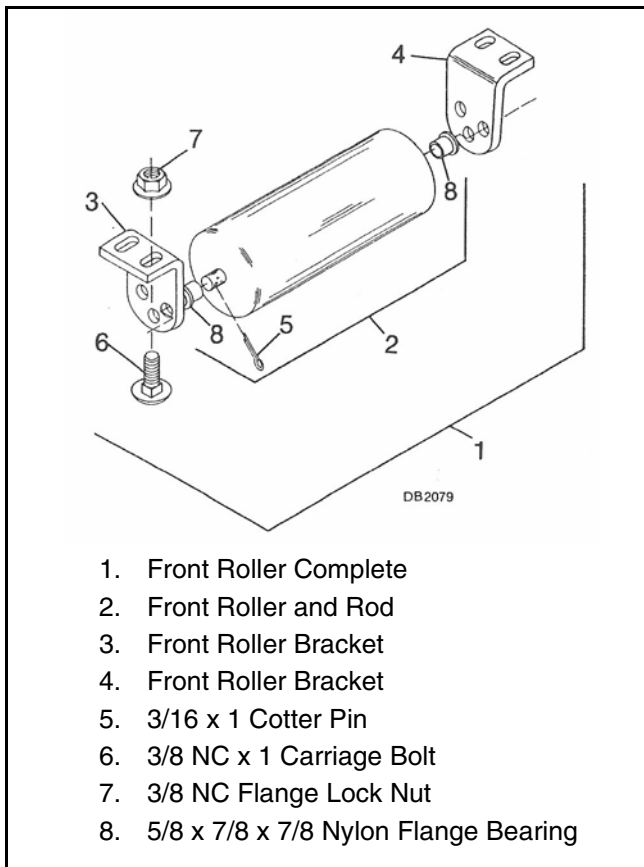

Figure 28. Front Roller

Leaf Mulcher

Bothersome leaf raking, bagging or burning can be minimized by equipping your mower with a leaf

mulcher attachment. With this attachment your mower will dispose of leaves by quickly and thoroughly shredding them. The shredded matter will decompose and form humus.

The use of extra suction blades is recommended with the leaf mulcher and it is also recommended that the leaf mulcher be removed for grass mowing.

Adjust mower with blades approximately 1-1/2" above ground and front of mower slightly higher than the rear. Operate tractor at a slow ground speed with the PTO at 1000 rpm.

Place mower upside down on saw horses or other supports.

Remove side shields but do not remove side skids.

Remove front roller if installed.

Remove center baffle and brackets.

Measure 17" from the mower center line to each side and mark. Measure 7/8" up from top of mower deck and drill three 7/16" holes.

Install attachment angle to leaf mulcher side brackets. Note the shape of attachment angle. Position as illustrated and attach with a 3/8" x 1" bolt, flat washer and nut.

Place leaf mulcher over blades.

Align attachment angles with fourth hole from front of mower and install between side shield and deck angle. Attach with 3/8" x 1-1/2" bolt and flange lock nut. Use two 3/8" flat washers as shims between side shield and deck angle rear hole.

Insert three 3/8" x 1" bolts through holes drilled in front lip of mower. Attach leaf mulcher directly to front lip of mower.

Insert 3/8" x 1" bolts through these holes and secure with a lock washer and 3/8" nut.

Tighten all bolts in leaf mulcher assembly.

Check blade clearance by turning each one by hand.

Should a blade contact a mulcher ring, re-shape ring as necessary.

Be sure to have 1/8" minimum clearance between blade tip and mulcher.

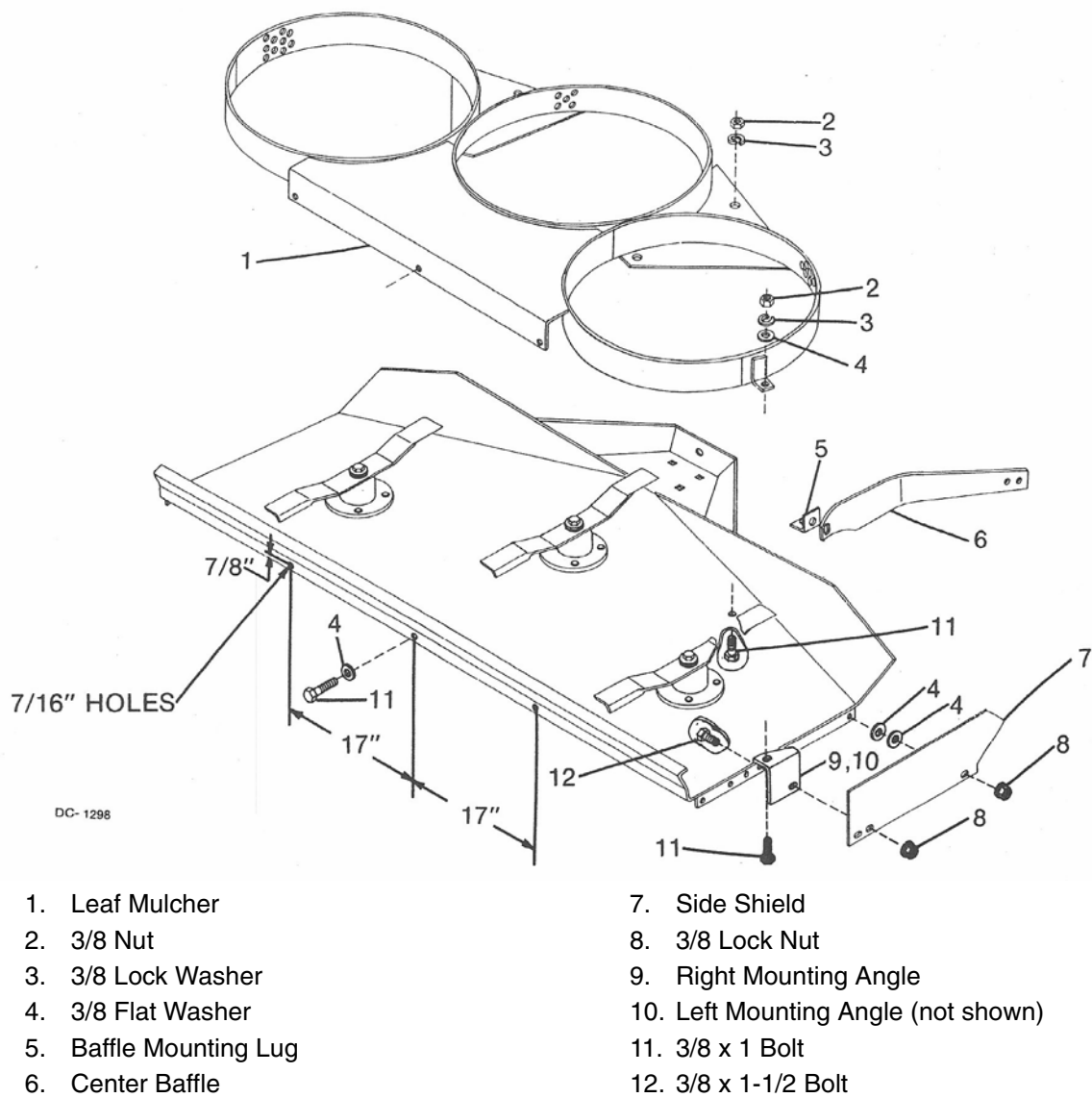

Figure 29. Leaf Mulcher

DEALER CHECK LISTS

PRE-DELIVERY CHECK LIST

Inspect the mower thoroughly after assembly to be certain it is set up properly before delivering it to the customer. The following check list is a reminder of points to inspect. Check off each item as it is found satisfactory or after proper adjustment is made.

- Check that all safety shields are in place.
- Check all bolts to be sure they are tight.
- Check that all cotter pins are properly installed.
- Check that all lubrication points with grease fittings have been lubricated.
- Check that blades have been properly installed.
- Check mower attitude, belt alignment and tension.

DELIVERY CHECK LIST

- Show customer how to make adjustments.
- Explain importance of lubrication to customer and point out lubrication points on mower.
- Point out safety features and options.
- Explain to customer that it is important the PTO should be operated at 1000 rpm maximum when mowing.
- Give the operator's manual to the customer and ask him to familiarize himself with all sections.
- Explain to the customer that when the mower is transported on a road or highway at night or during the day, safety devices should be used for adequate warning to operators of other vehicles.

L306 K50 FRAME ASSEMBLY

NOTE: Belt take-up assembly part #24255 required to replace item 8.

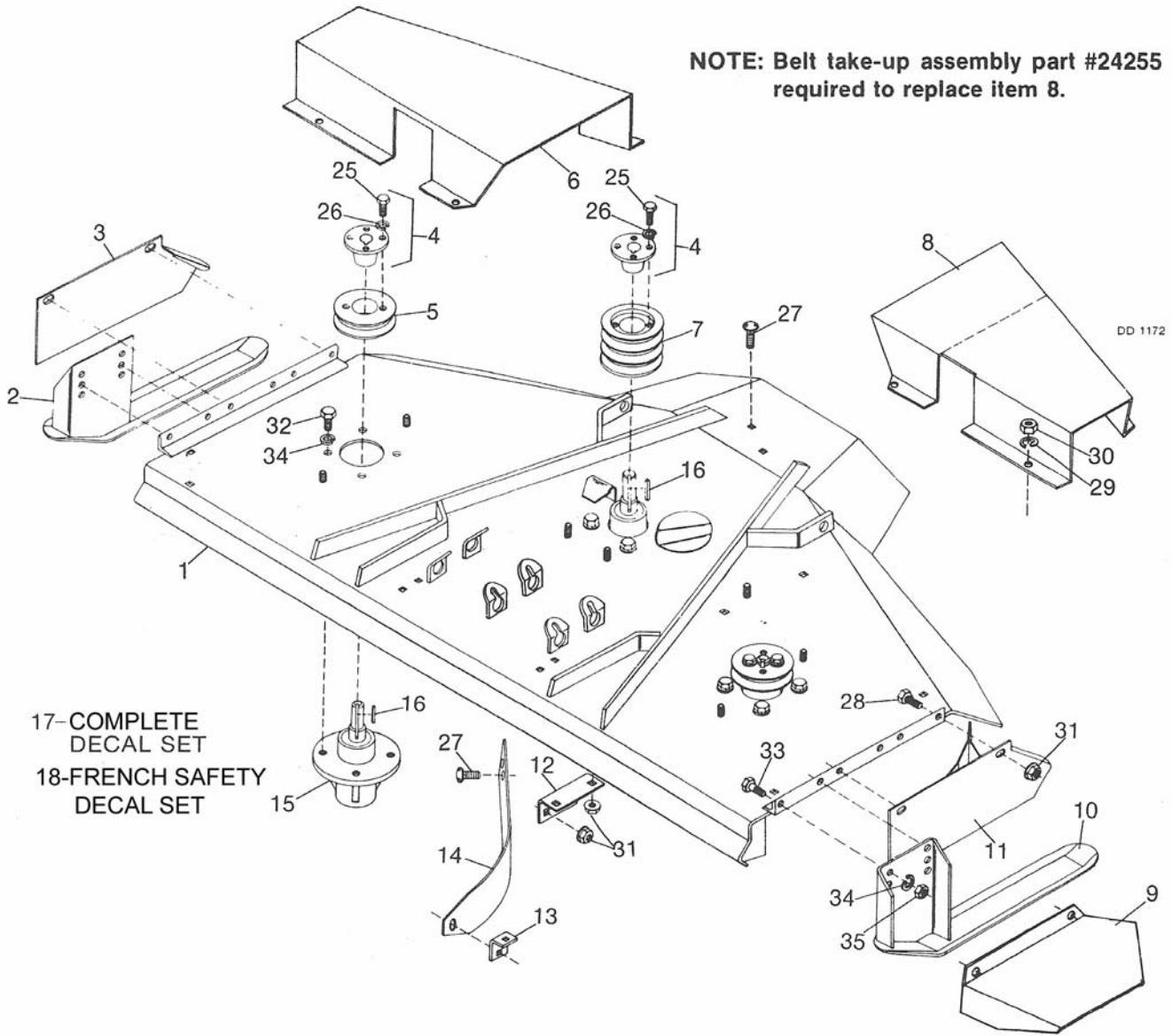

17-COMplete
DECAL SET
18-FRENCH SAFETY
DECAL SET

REF	PART	QTY	DESCRIPTION	REF	PART	QTY	DESCRIPTION
1	9702	1	Frame w/baffling, spindles, shields, etc.	16	3885 *	3	3/16 x 3/16 x 1-1/4 Key
2	13428	1	Right side skid	17	32691	1	Complete decal set
3	24188	1	Right side shield	18	52311	1	French safety decal set
4	4227	3	H 3/4 Straight bushing with bolts	25	10378 *		1/4 NC x 1 HHCS GR5
5	12622	2	1 BK 5.0 H Sheave (single groove)	26	1985 *		1/4 Standard lock washer
6	25528	1	Right belt shield	27	24597 *		3/8 NC x 3/4 Carriage bolt
7	13417	1	3 BK H5 Sheave (3 groove)	28	839 *		3/8 NC x 1 HHCS GR5
8	24255	1	Belt take-up assembly (see page 32)	29	838 *		3/8 Standard lock washer
9	26522	1	Side disc chute	30	835 *		3/8 NC Hex nut, plated
10	13429	1	Left side skid, white	31	14350		3/8 NC Flanged hex lock nut
11	24189	1	Left side shield	32	4119		1/2 NF x 1 HHCS GR5
12	25532	1	Center baffle rear mounting angle	33	6100 *		1/2 NC x 1-1/4 HHCS GR5
13	25530	1	Center baffle front mounting lug	34	855 *		1/2 X-Heavy lock washer
14	25533	1	Frame center baffle	35	1093 *		1/2 NC Heavy hex nut
15	3761	3	Fixed blade spindle (see page 31)				

* Standard hardware, obtain locally

28 Parts

32695 (Rev. 11/17/2006)

L306 K50 MOUNTING FRAME ASSEMBLY (REAR)

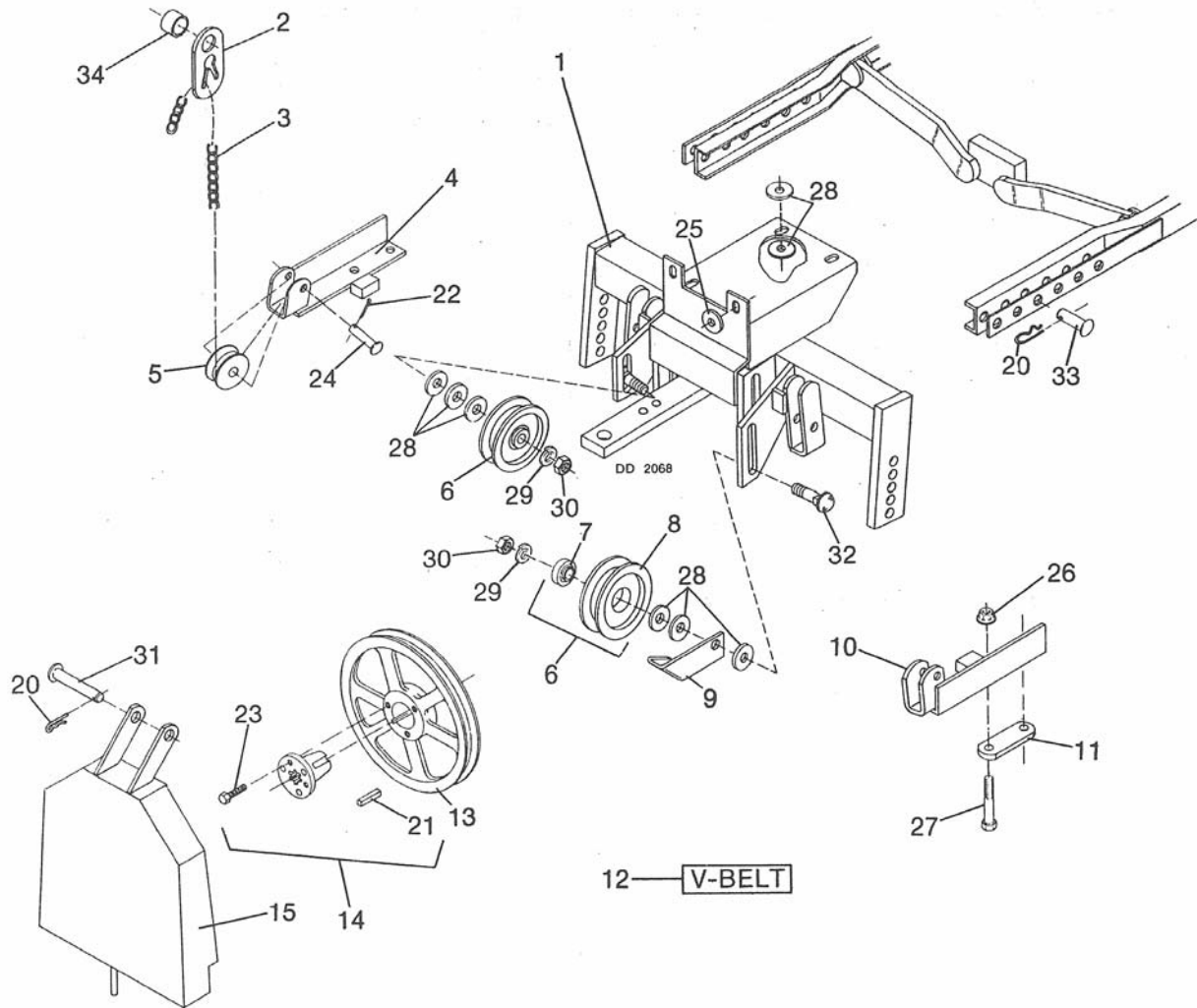

REF	PART	QTY	DESCRIPTION	REF	PART	QTY	DESCRIPTION
1	8968	1	Idler bracket	21	29714	1	3/16 x 3/8 x 1 Key
2	30169	2	Rear lift lug	22	1256 *	1	3/16 x 1 Cotter pin
3	17477	2	4/0 Twist link chain, 84" long	23	2457 *	1	1/4 NC x 3/4 HHCS GR5
4	33099	1	Left rear lift angle assembly	24	409	1	1/2 x 2 Clevis pin
5	6696	2	Chain idler casting	25	854 *	1	1/2 Standard flat washer
6	4336	2	V-Groove idler with bearing	26	11900	1	1/2 NC Flanged hex lock nut
7	6095	2	.635 ID x 1.85 OD Ball bearing	27	12024 *	1	1/2 NC x 3-3/4 HHCS GR5
8	4335	2	4.5 OD V-Groove idler	28	692 *	1	5/8 Standard flat washer
9	29718	1	V-Belt guide	29	1286 *	1	5/8 Heavy lock washer
10	33098	1	Right rear lift angle assembly	30	230 *	1	5/8 NC Hex nut
11	33097	2	Rear lift bracket clamp bar	31	8099	1	5/8 x 3-1/2 Clevis pin
12	32970	1	W191 V-Belt	32	5079	1	5/8 NC x 2-1/4 Carriage bolt
13	23169	1	1 BK H 10.9 PD Sheave, keyed	33	410	1	5/8 x 1-3/4 Clevis pin
14	29715	1	H 1-3/8 6B Splined bushing & key	34	33106	1	1" Schedule 40 x 1-1/4 pipe, painted
15	29720	1	Rear belt shield				
20	2688 *	1	1/8 Safety pin				

* Standard hardware, obtain locally

L306 K50 MOUNTING FRAME ASSEMBLY (FRONT)

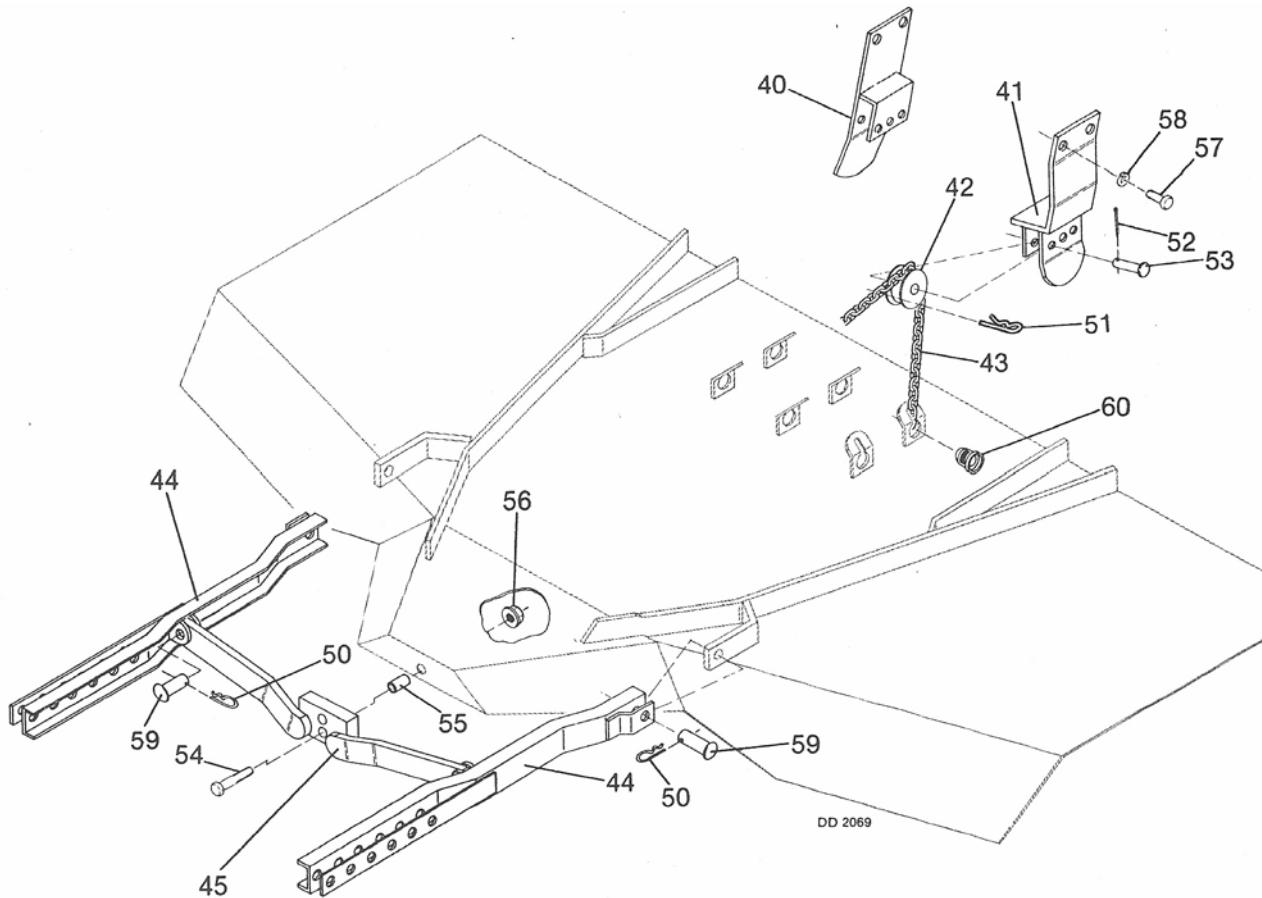

REF	PART	QTY	DESCRIPTION	REF	PART	QTY	DESCRIPTION
40	33093	1	Left front lift bracket	54	3699 *	1/2 NC x 2 HHCS GR5	
41	33092	1	Right front lift bracket	55	3504	1/2 x 5/8 x 1-1/16 Sleeve, heat-treated	
42	6696	2	Chain idler casting	56	11900	1/2 NC Flanged hex lock nut	
43	17477	2	4/0 Twist link chain, 84" long	57	16087	14 mm x 1.5P x 35 mm HHCS GR8.8	
44	23928	2	Push channel assembly	58	1286 *	5/8 Heavy lock washer	
45	27980	1	Crosswise rear support	59	4097	5/8 x 1-1/2 Clevis pin	
50	2688 *	1	1/8 Safety pin	60	18336	Caplug 1-1/16 - 121D SAE thread	
51	18270 *	1	3/16 Safety pin				
52	1256 *	1	3/16 x 1 Cotter pin				
53	409	1	1/2 x 2 Clevis pin				

* Standard hardware, obtain locally

30 Parts

32695 (Rev. 11/17/2006)

L306 K50 BLADE ASSEMBLY

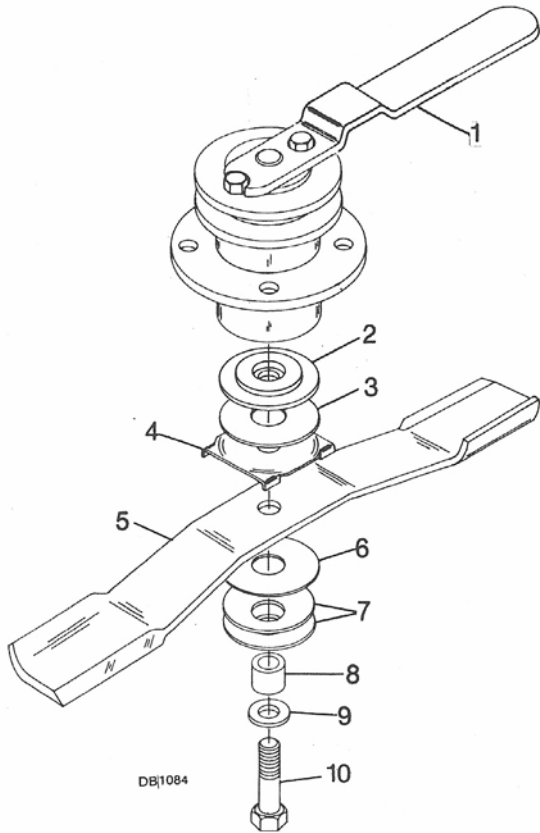

REF	PART	QTY	DESCRIPTION
1	2974	1	Spindle lock wrench, white
2	13409	1	5/8 ID x 3 Shoulder washer
3	13402	1	1 x 3 Friction disc
4	13403	1	Blade lock
5	13404KT	1	CCW 24-1/2 Blade (standard) -or-
5	28328KT	1	CCW 24-1/2 Low suction blade (optional)
6	13405	A/R	1 x 3 x 20 GA Flat washer
7	13401	2	1 x 2-3/4 x 11 GA Cup washer
8	12313	1	5/8 x 1 x 13/16 Heat-treated sleeve
9	13451	1	5/8 x 1-1/4 x 13/64 HT Washer
10	24184	1	5/8 NC x 2-3/8 Nylock cap screw, HT (left hand threads)

A/R As required

L306 K50 BLADE SPINDLE ASSEMBLY

REF	PART	QTY	DESCRIPTION
1	3761	1	Fixed blade spindle (left hand rotation)
2	4117	1	Spindle housing (includes bearing cups)
3	5089	2	Seal for 1-1/16 shaft
4	4114	1	27/32 x 1-1/16 x 1-7/16 Sleeve
5	4115 *	1	3/16 x 1-1/8 Spring pin
6	4107	2	Bearing cone
7	4106	2	Bearing cup
8	1972 *	1	1/4 - 28 Taper thread grease fitting
9	28897	1	Spindle shaft, HT (left hand threads)

* Standard hardware, obtain locally

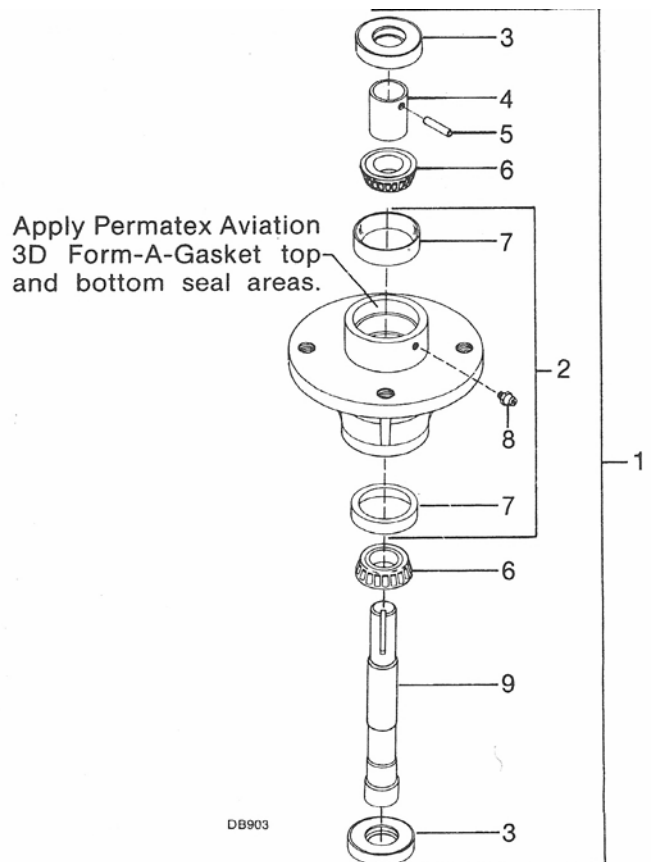

L306 K50 BELT TAKE-UP ASSEMBLY

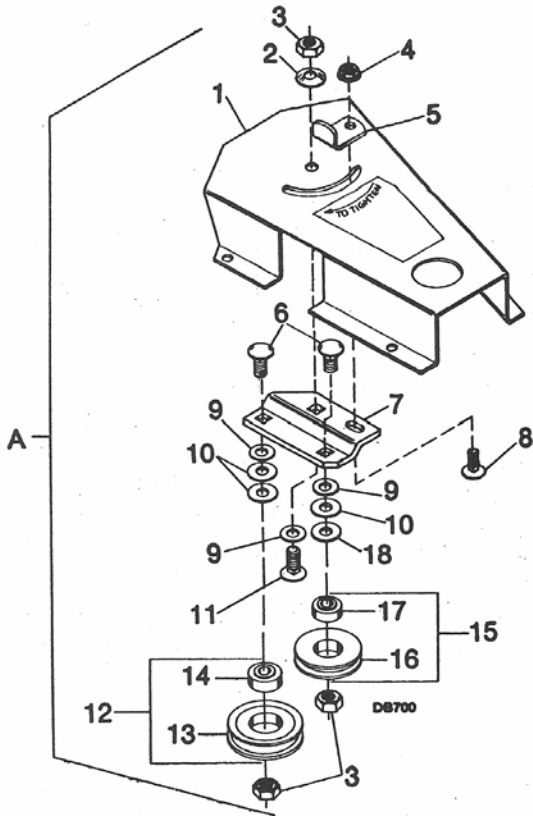

REF	PART	QTY	DESCRIPTION
A	24255	1	Belt take-up assembly (complete)
1	24253	1	Belt take-up shield
2	10635	1	5/8 x 1-3/4 x 14 GA Cup washer
3	230 *	3	5/8 NC Hex lock nut
4	11900	1	1/2 NC Flanged hex lock nut
5	24258	1	Belt take-up adjustment angle, white
6	5079	2	5/8 NC x 2-1/4 Carriage bolt
7	24254	1	Belt take-up idler plate
8	2615 *	1	1/2 NC x 1-1/4 Carriage bolt GR5
9	28539	3	7/8 Standard SAE flat washer
10	692 *	3	5/8 Standard flat washer
11	5607 *	1	5/8 NC x 1-1/2 Carriage bolt
12	5073	1	4-5/8 OD Flat idler and bearing
13	13100	1	4-5/8 OD Flat idler less bearing
14	6095	1	.635 ID x 1.85 OD Ball bearing
15	23000 *	1	5/8 Bore 4 OD B-groove idler & bearing
16	24450	1	4 OD B-Groove idler sheave less bearing
17	24259	1	.625 ID x 1.78 OD Ball bearing
18	23306	1	5/8 x 1-1/16 x 10 GA Flat washer

* Standard hardware, obtain locally

FRONT ROLLER ASSEMBLY (OPTIONAL)

REF	PART	QTY	DESCRIPTION
1	24650	1	Front roller bundle complete
2	24583	1	Front roller bearing & rod
3	24586	1	Right front roller bracket, white
4	24587	1	Left front roller bracket, white
5	1256 *	-	3/16 x 1 Cotter pin
6	6697 *	-	3/8 NC x 1 Carriage bolt
7	14350	-	3/8 NC Flanged hex lock nut
8	29610	2	5/8 x 7/8 x 7/8 Nylon flange bearing

* Standard hardware, obtain locally

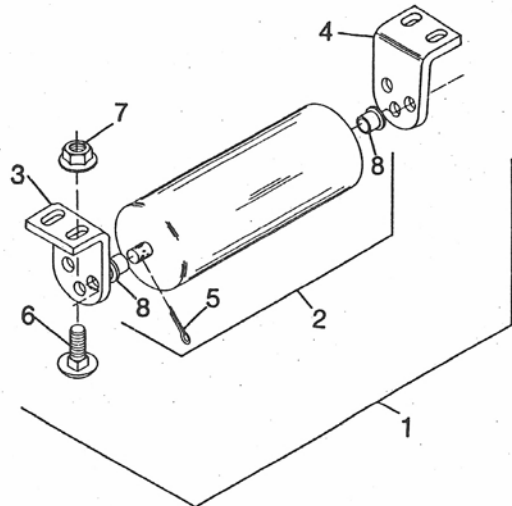

L306 K50 CASTER ASSEMBLY (OPTIONAL)

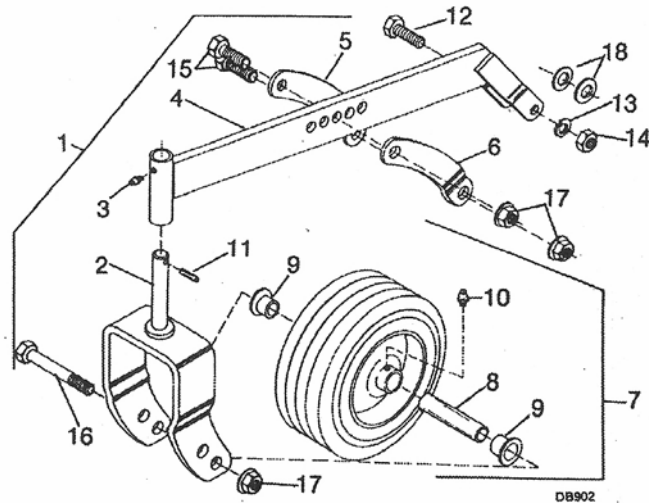

REF	PART	QTY	DESCRIPTION	REF	PART	QTY	DESCRIPTION
1	24095	1	Set of two L306 casters	10	2909 *	1	Straight 1/4 self-tap grease fitting (for steel wheel) -or-
2	23857	1	Caster wheel yoke assembly, white	10	195 *	1	Straight 1/8 P thread grease fitting (for polyethylene wheel)
3	12296 *	1	1/4-28 Straight grease fitting 15/32"	11	21020	-	1/4 x 1-1/4 Spiral pin
4	13435	1	Caster arm assembly, white	12	976 *	-	3/8 NC x 1-1/2 HHCS GR5
5	13444	1	Right caster adjustment bracket, white	13	838 *	-	3/8 Standard lock washer
6	13445	1	Left caster adjustment bracket, white	14	835 *	-	3/8 NC Hex nut, plated
7	15638	1	Wheel 10" CFLNG w/sleeve	15	24576	-	1/2 x 1-3/4 HHCS GR5
8	29368	1	1/2 x 3/4 x 3-3/8 Sleeve	16	23479	-	1/2 x 5 HHCS GR5
9	29375	2	3/4 Bore x 1-1/8 flange bearing (for steel wheel) -or-	17	11900 *	-	1/2 NC Flange hex lock nut
9	16237	2	.75 Bore x 1-3/8 flange bearing w/notch -or-	18	854 *	-	1/2 Standard flat washer
9	65578	2	.75 x 1.385 Flg whl bearing (for polyethylene wheel)				* Standard hardware, obtain locally

LEAF MULCHER ASSEMBLY (OPTIONAL)

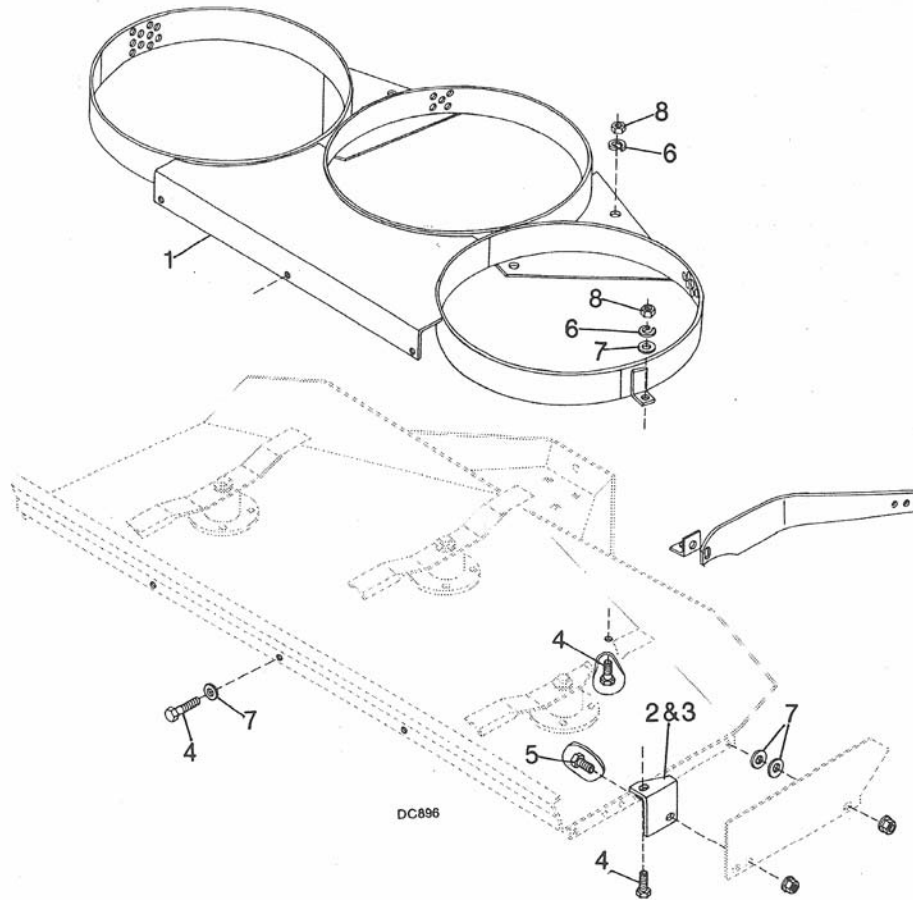

REF	PART	QTY	DESCRIPTION	REF	PART	QTY	DESCRIPTION
A	13482	1	Leaf mulcher complete	5	976 *	-	3/8 NC x 1-1/2 HHCS GR5
1	-----	1	Leaf mulcher weldment	6	838 *	-	3/8 Standard lock washer
2	13224	1	Leaf mulcher right mounting bracket	7	565 *	-	3/8 Standard flat washer
3	13225	1	Leaf mulcher left mounting bracket (not shown)	8	835 *	-	3/8 NC Hex nut, plated
4	839 *	-	3/8 NC x 1 HHCS GR5				* Standard hardware, obtain locally

34 Parts

32695 (Rev. 11/17/2006)

BOLT TORQUE CHART

Always tighten hardware to these values unless a different torque value or tightening procedure is listed for a specific application.

Fasteners must always be replaced with the same grade as specified in the manual parts list.

Always use the proper tool for tightening hardware: SAE for SAE hardware and Metric for metric hardware.

Make sure fastener threads are clean and you start thread engagement properly.

All torque values are given to specifications used on hardware defined by SAE J1701 MAR 99 & J1701M JUL 96.

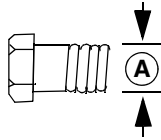

SAE SERIES TORQUE CHART

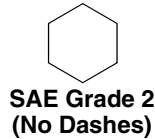

SAE Bolt Head Identification



Ⓐ Diameter (Inches)	Wrench Size	MARKING ON HEAD					
		SAE 2		SAE 5		SAE 8	
		lbs-ft	N-m	lbs-ft	N-m	lbs-ft	N-m
1/4"	7/16"	6	8	10	13	14	18
5/16"	1/2"	12	17	19	26	27	37
3/8"	9/16"	23	31	35	47	49	67
7/16"	5/8"	36	48	55	75	78	106
1/2"	3/4"	55	75	85	115	120	163
9/16"	13/16"	78	106	121	164	171	232
5/8"	15/16"	110	149	170	230	240	325
3/4"	1-1/8"	192	261	297	403	420	569
7/8"	1-5/16"	306	416	474	642	669	907
1"	1-1/2"	467	634	722	979	1020	1383

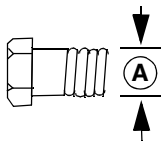

METRIC SERIES TORQUE CHART

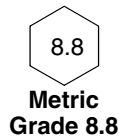

Metric Bolt Head Identification

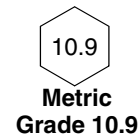

Ⓐ Diameter & Thread Pitch (Millimeters)	Wrench Size	COARSE THREAD				FINE THREAD				Ⓐ Diameter & Thread Pitch (Millimeters)
		MARKING ON HEAD				MARKING ON HEAD				
		Metric 8.8		Metric 10.9		Metric 8.8		Metric 10.9		
		N-m	lbs-ft	N-m	lbs-ft	N-m	lbs-ft	N-m	lbs-ft	
6 x 1.0	10 mm	8	6	11	8	8	6	11	8	6 x 1.0
8 x 1.25	13 mm	20	15	27	20	21	16	29	22	8 x 1.0
10 x 1.5	16 mm	39	29	54	40	41	30	57	42	10 x 1.25
12 x 1.75	18 mm	68	50	94	70	75	55	103	76	12 x 1.25
14 x 2.0	21 mm	109	80	151	111	118	87	163	120	14 x 1.5
16 x 2.0	24 mm	169	125	234	173	181	133	250	184	16 x 1.5
18 x 2.5	27 mm	234	172	323	239	263	194	363	268	18 x 1.5
20 x 2.5	30 mm	330	244	457	337	367	270	507	374	20 x 1.5
22 x 2.5	34 mm	451	332	623	460	495	365	684	505	22 x 1.5
24 x 3.0	36 mm	571	421	790	583	623	459	861	635	24 x 2.0
30 x 3.0	46 mm	1175	867	1626	1199	1258	928	1740	1283	30 x 2.0

Typical Washer Installations

Lock Washer

Flat Washer

Bolt

8/9/00

BOLT SIZE CHART

NOTE: Chart shows bolt thread sizes and corresponding head (wrench) sizes for standard SAE and metric bolts.

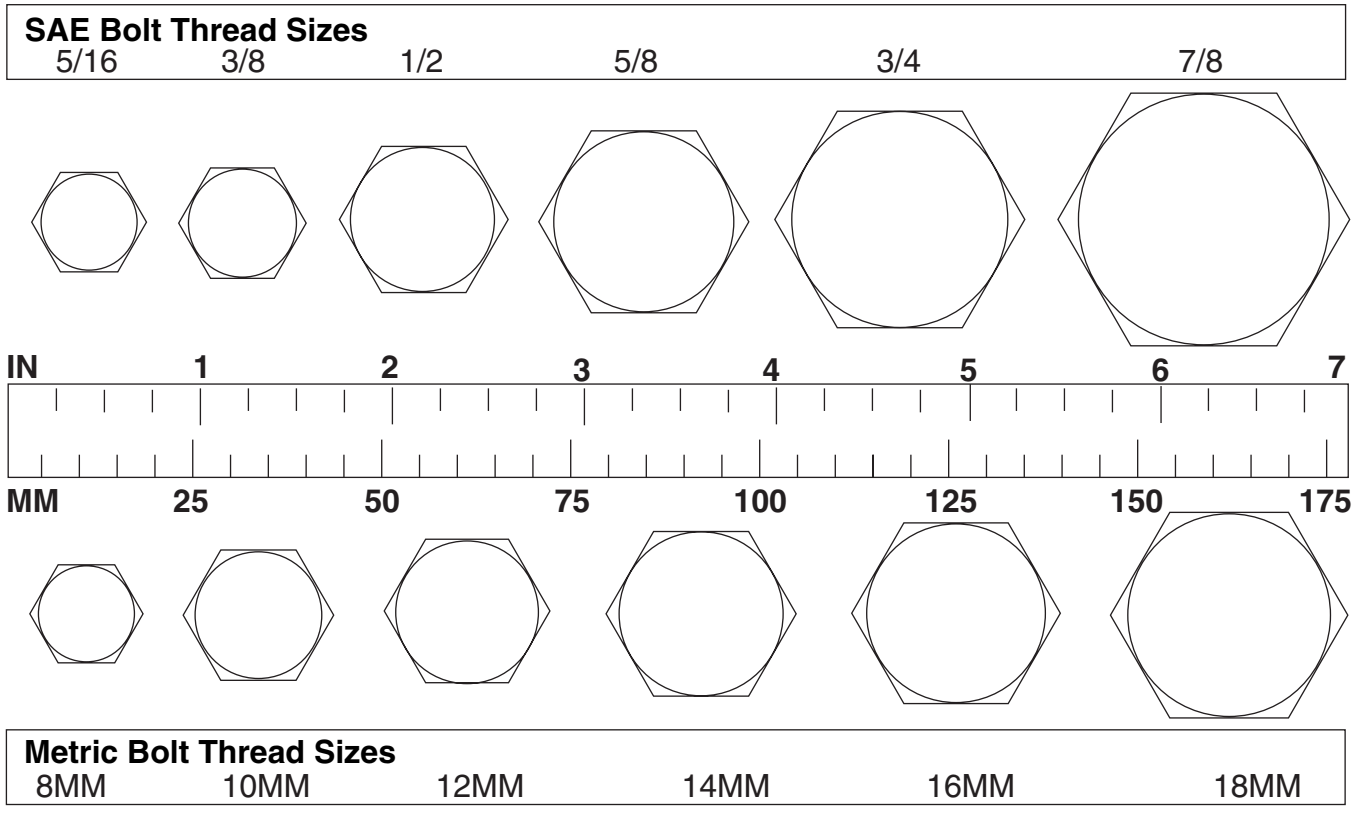

ABBREVIATIONS

AG Agriculture
 ATF Automatic Transmission Fluid
 BSPP British Standard Pipe Parallel
 BSPTM British Standard Pipe Tapered Male
 CV Constant Velocity
 CCW Counter-Clockwise
 CW Clockwise
 F Female
 GA Gauge
 GR (5, etc.) Grade (5, etc.)
 HHCS Hex Head Cap Screw
 HT Heat-Treated
 JIC Joint Industry Council 37° Degree Flare
 LH Left Hand
 LT Left
 m Meter
 mm Millimeter
 M Male
 MPa Mega Pascal
 N Newton

NC National Coarse
 NF National Fine
 NPSM National Pipe Straight Mechanical
 NPT National Pipe Tapered
 NPT SWF National Pipe Tapered Swivel Female
 ORBM O-Ring Boss - Male
 P Pitch
 PBY Power-Beyond
 psi Pounds per Square Inch
 PTO Power Take Off
 QD Quick Disconnect
 RH Right Hand
 ROPS Roll-Over Protective Structure
 RPM Revolutions Per Minute
 RT Right
 SAE Society of Automotive Engineers
 UNC Unified Coarse
 UNF Unified Fine
 UNS Unified Special

INDEX

Assembly 18

Dealer Check Lists 27

- Delivery 27
- Pre-Delivery 27

Dealer Service 14

- Pulley Installation 15
- Spindle Inspection 14
- Spindle Removal 14
- Spindle Repair 14
 - Assembly 15
 - Disassembly 14
- Spindle Installation 15

General

- Abbreviations 36
- Bolt Size Chart 36
- Bolt Torque Chart 35
- General Information 4
- General information 4
- Introduction 2
- Obtaining Replacement Manuals 2
- Specifications 4
- Warranty
 - Product 39
 - Replacement Parts 38

Operation 8

- Blades 11
- Cleaning 11
- Cutting Height Adjustment 8
 - Attitude Adjustment 8
 - Side Skid Adjustment 9

- With Casters 8
- Daily Check List 8
- Mowing Techniques 10
 - Mowing Speed 10
 - Mowing Tips 10
- Pre-Operation Check List 9
- Starting & Stopping Mower 9
 - Commencing Mower 9
- Uneven Terrain 11

Optional Equipment 24

- Blades 24
- Casters 24
- Front Roller 24
- Leaf Mulcher 25

Owner Service 12

- Belt Installation 12
- Blade Installation 12
- Blade Removal 12
- Blade Servicing 12
- Blade Sharpening 12
- Lubrication 13

Parts Lists 28

Safety

- Safety & Instructional Decals 7
- Safety Rules 5
- Safety Symbols Explained 2

Trouble Shooting 16

- Belt Conditions 16
- Mowing Conditions 17



WARRANTY

(All Models Except Mow'n Machine™ Zero-Turn Mowers and Woods Boundary™ Utility Vehicles)

Please Enter Information Below and Save for Future Reference.

Date Purchased: _____

From (Dealer): _____

Model Number: _____

Serial Number: _____

Woods Equipment Company ("WOODS") warrants this product to be free from defect in material and workmanship. Except as otherwise set forth below, the duration of this Warranty shall be for TWELVE (12) MONTHS COMMENCING ON THE DATE OF DELIVERY OF THE PRODUCT TO THE ORIGINAL PURCHASER.

Woods backhoe models BH70-X, BH80-X, and BH90-X are warranted for two (2) years from the date of delivery to the original purchaser.

The warranty periods for specific parts or conditions are listed below:

Model Number	Part or Condition Warranted	Duration (from date of delivery to the original purchaser)
PHD25, PHD35, PHD65, PHD95, 1260, 2162, 3240, BB48, BB60, BB72, BB84, BB600, BB720, BB840, BB6000, BB7200, BB8400, BW180-2, BW1800, DS96, DS120, RCC42, RM550-2, RM660-2, RM990-3, PRD6000, PRD7200, PRD8400, 7144RD-2, 9180RD-2, 9204RD-2, S15CD, S20CD, S22CD, S25CD, S27CD	Gearbox components	5 years
RDC54, RD60, RD72	Gearbox components	3 years (1 year if used in rental or commercial applications)
RM550-2, RM660-2, RM990-3, PRD6000, PRD7200, PRD8400, 7144RD-2, 9180RD-2, 9204RD-2	Blade spindles	3 years
BB600, BB720, BB840, BB6000, BB7200, BB8400, BW126, BW180, BW1260, BW1800, 1260, 2162, 3240	Rust-through	10 years

Under no circumstances will this Warranty apply in the event that the product, in the good faith opinion of WOODS, has been subjected to improper operation, improper maintenance, misuse, or an accident. This Warranty does not apply in the event that the product has been materially modified or repaired by someone other than WOODS, a WOODS authorized dealer or distributor, and/or a WOODS authorized service center. This Warranty does not cover normal wear or tear, or normal maintenance items. This Warranty also does not cover repairs made with parts other than those obtainable through WOODS.

This Warranty is extended solely to the original purchaser of the product. Should the original purchaser sell or otherwise transfer this product to a third party, this Warranty does not transfer to the third party purchaser in any way. There are no third party beneficiaries of this Warranty.

WOODS makes no warranty, express or implied, with respect to engines, batteries, tires or other parts or accessories not manufactured by WOODS. Warranties for these items, if any, are provided separately by their respective manufacturers.

WOODS' obligation under this Warranty is limited to, at WOODS' option, the repair or replacement, free of charge, of the product if WOODS, in its sole discretion, deems it to be defective or in noncompliance with this Warranty. **The product must be returned to WOODS with proof of purchase within thirty (30) days after such defect or noncompliance is discovered or should have been discovered, routed through the dealer and distributor from whom the purchase was made, transportation charges prepaid.** WOODS shall complete such repair or replacement within a reasonable time after WOODS receives the product. THERE ARE NO OTHER REMEDIES UNDER THIS WARRANTY. THE REMEDY OF REPAIR OR REPLACEMENT IS THE SOLE AND EXCLUSIVE REMEDY UNDER THIS WARRANTY.

THERE ARE NO WARRANTIES WHICH EXTEND BEYOND THE DESCRIPTION ON THE FACE OF THIS WARRANTY. WOODS MAKES NO OTHER WARRANTY, EXPRESS OR IMPLIED, AND WOODS SPECIFICALLY DISCLAIMS ANY IMPLIED WARRANTY OF MERCHANTABILITY AND/OR ANY IMPLIED WARRANTY OF FITNESS FOR A PARTICULAR PURPOSE.

WOODS shall not be liable for any incidental or consequential losses, damages or expenses, arising directly or indirectly from the product, whether such claim is based upon breach of contract, breach of warranty, negligence, strict liability in tort or any other legal theory. Without limiting the generality of the foregoing, Woods specifically disclaims any damages relating to (i) lost profits, business, revenues or goodwill; (ii) loss of crops; (iii) loss because of delay in harvesting; (iv) any expense or loss incurred for labor, supplies, substitute machinery or rental; or (v) any other type of damage to property or economic loss.

This Warranty is subject to any existing conditions of supply which may directly affect WOODS' ability to obtain materials or manufacture replacement parts.

No agent, representative, dealer, distributor, serviceperson, salesperson, or employee of any company, including without limitation, WOODS, its authorized dealers, distributors, and service centers, is authorized to alter, modify, or enlarge this Warranty.

Answers to any questions regarding warranty service and locations may be obtained by contacting:

Woods Equipment Company

2606 South Illinois Route 2
Post Office Box 1000
Oregon, Illinois 61061

800-319-6637 tel
800-399-6637 fax
www.WoodsEquipment.com



ALITEC™

BMP®

CENTRAL FABRICATORS®

GANNON®

GILL®

WAIN-ROY®

WOODS®



WARRANTY

(Replacement Parts For All Models Except Mow'n Machine™
Zero-Turn Mowers and Woods Boundary™ Utility Vehicles)

Woods Equipment Company ("WOODS") warrants this product to be free from defect in material and workmanship for a period of ninety (90) days from the date of delivery of the product to the original purchaser with the exception of V-belts, which will be free of defect in material and workmanship for a period of 12 months.

Under no circumstances will this Warranty apply in the event that the product, in the good faith opinion of WOODS, has been subjected to improper operation, improper maintenance, misuse, or an accident. This Warranty does not cover normal wear or tear, or normal maintenance items.

This Warranty is extended solely to the original purchaser of the product. Should the original purchaser sell or otherwise transfer this product to a third party, this Warranty does not transfer to the third party purchaser in any way. There are no third party beneficiaries of this Warranty.

WOODS' obligation under this Warranty is limited to, at WOODS' option, the repair or replacement, free of charge, of the product if WOODS, in its sole discretion, deems it to be defective or in noncompliance with this Warranty. **The product must be returned to WOODS with proof of purchase within thirty (30) days after such defect or noncompliance is discovered or should have been discovered, routed through the dealer and distributor from whom the purchase was made, transportation charges prepaid.** WOODS shall complete such repair or replacement within a reasonable time after WOODS receives the product. THERE ARE NO OTHER REMEDIES UNDER THIS WARRANTY. THE REMEDY OF REPAIR OR REPLACEMENT IS THE SOLE AND EXCLUSIVE REMEDY UNDER THIS WARRANTY.

THERE ARE NO WARRANTIES WHICH EXTEND BEYOND THE DESCRIPTION ON THE FACE OF THIS WARRANTY. WOODS MAKES NO OTHER WARRANTY, EXPRESS OR IMPLIED, AND WOODS SPECIFICALLY DISCLAIMS ANY IMPLIED WARRANTY OF MERCHANTABILITY AND/OR ANY IMPLIED WARRANTY OF FITNESS FOR A PARTICULAR PURPOSE.

WOODS shall not be liable for any incidental or consequential losses, damages or expenses, arising directly or indirectly from the product, whether such claim is based upon breach of contract, breach of warranty, negligence, strict liability in tort or any other legal theory. Without limiting the generality of the foregoing, Woods specifically disclaims any damages relating to (i) lost profits, business, revenues or goodwill; (ii) loss of crops; (iii) loss because of delay in harvesting; (iv) any expense or loss incurred for labor, supplies, substitute machinery or rental; or (v) any other type of damage to property or economic loss.

This Warranty is subject to any existing conditions of supply which may directly affect WOODS' ability to obtain materials or manufacture replacement parts.

No agent, representative, dealer, distributor, service person, salesperson, or employee of any company, including without limitation, WOODS, its authorized dealers, distributors, and service centers, is authorized to alter, modify, or enlarge this Warranty.

Answers to any questions regarding warranty service and locations may be obtained by contacting:

Woods Equipment Company

2606 South Illinois Route 2
Post Office Box 1000
Oregon, Illinois 61061

800-319-6637 tel
800-399-6637 fax
www.WoodsEquipment.com

WOODS®

ALITEC™

BMP®

CENTRAL FABRICATORS®

GANNON®

GILL®

WAIN-ROY®

WOODS®

32695

**Woods Equipment
Company**

2606 South Illinois Route 2
Post Office Box 1000
Oregon, Illinois 61061

815-732-2141 tel
815-732-7580 fax
www.WoodsEquipment.com

WOODS®

© 2004 Woods Equipment Company. All rights reserved. WOODS, the Woods logo, and "Tested. Proven. Unbeatable." are trademarks of Woods Equipment Company. All other trademarks, trade names, or service marks not owned by Woods Equipment Company that appear in this manual are the property of their respective companies or mark holders. Specifications subject to change without notice.

Free Manuals Download Website

<http://myh66.com>

<http://usermanuals.us>

<http://www.somanuals.com>

<http://www.4manuals.cc>

<http://www.manual-lib.com>

<http://www.404manual.com>

<http://www.luxmanual.com>

<http://aubethermostatmanual.com>

Golf course search by state

<http://golfingnear.com>

Email search by domain

<http://emailbydomain.com>

Auto manuals search

<http://auto.somanuals.com>

TV manuals search

<http://tv.somanuals.com>