

WOODS REAR DISCHARGE MOWERS

RD6000-2
RD7200-2
RD8400-2

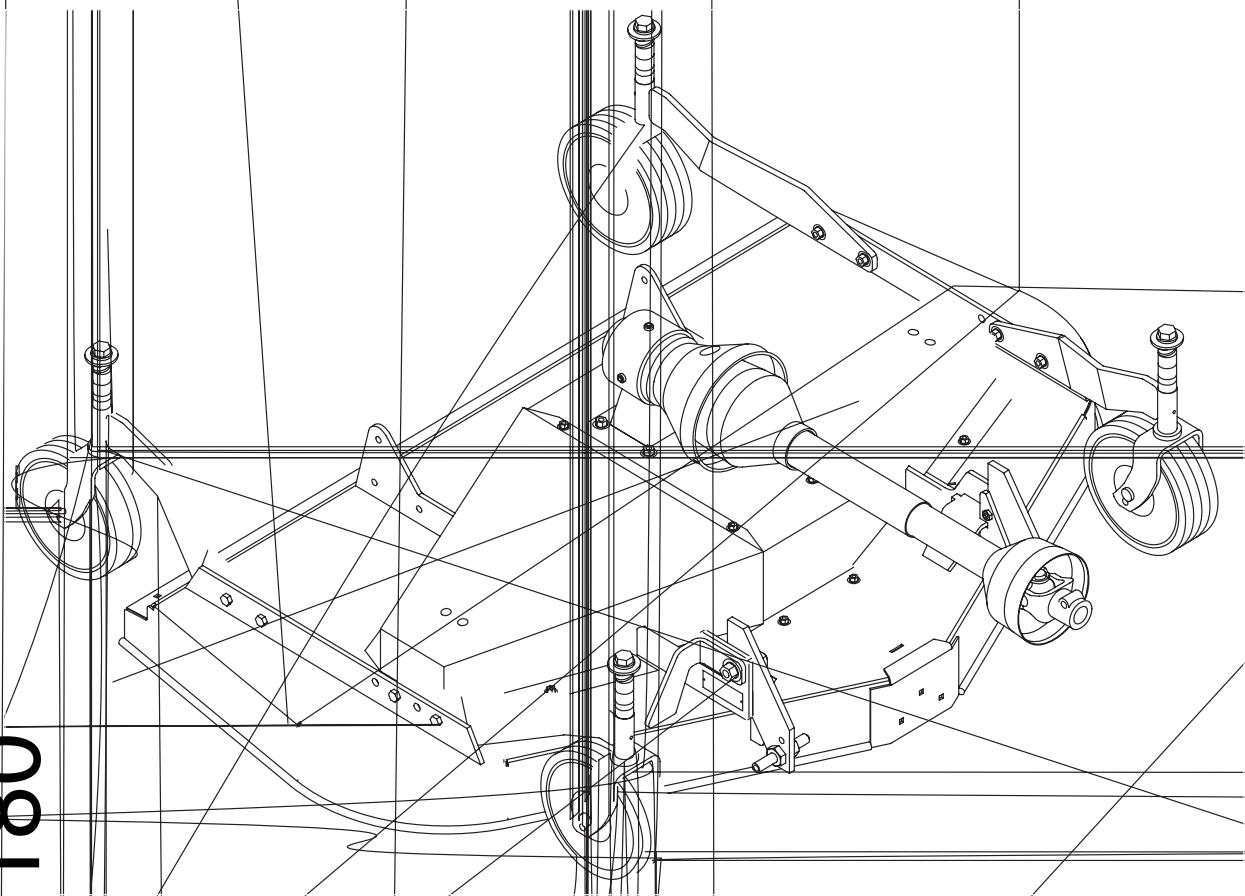

MAN0180

Rev. 4/28/2006

WOODS®
Tested. Proven. Unbeatable.

OPERATOR'S MANUAL

TO THE DEALER:

Assembly and proper installation of this product is the responsibility of the Woods® dealer. Read manual instructions and safety rules. Make sure all items on the Dealer's Pre-Delivery and Delivery Check Lists in the Operator's Manual are completed before releasing equipment to the owner.

The dealer must complete the Product Registration included with the Operator's Manual. The customer must sign the registration which certifies that all Dealer Check List items have been completed. The dealer is to return the prepaid postage portion to Woods, give one copy to the customer, and retain one copy. **Failure to complete and return this card does not diminish customer's warranty rights.**

TO THE OWNER:

Read this manual before operating your Woods equipment. The information presented will prepare you to do a better and safer job. Keep this manual handy for ready reference. Require all operators to read this manual carefully and become acquainted with all adjustment and operating procedures before attempting to operate. Replacement manuals can be obtained from your dealer. To locate your nearest dealer, check the Dealer Locator at www.WoodsEquipment.com, or in the United States and Canada call 1-800-319-6637.

The equipment you have purchased has been carefully engineered and manufactured to provide dependable and satisfactory use. Like all mechanical products, it will require cleaning and upkeep. Lubricate the unit as specified. Observe all safety information in this manual and safety decals on the equipment.

For service, your authorized Woods dealer has trained mechanics, genuine Woods service parts, and the necessary tools and equipment to handle all your needs.

Use only genuine Woods service parts. Substitute parts will void the warranty and may not meet standards required for safe and satisfactory operation. Record the model number and serial number of your equipment in the spaces provided:

Model: _____ **Date of Purchase:** _____

Serial Number: (see Safety Decal section for location) _____

Provide this information to your dealer to obtain correct repair parts.

Throughout this manual, the term **IMPORTANT** is used to indicate that failure to observe can cause damage to equipment. The terms **CAUTION**, **WARNING**, and **DANGER** are used in conjunction with the Safety-Alert Symbol (a triangle with an exclamation mark) to indicate the degree of hazard for items of personal safety.



This Safety-Alert Symbol indicates a hazard and means **ATTENTION! BECOME ALERT! YOUR SAFETY IS INVOLVED!**



DANGER

Indicates an imminently hazardous situation that, if not avoided, will result in death or serious injury.



WARNING

Indicates a potentially hazardous situation that, if not avoided, could result in death or serious injury, and includes hazards that are exposed when guards are removed.



CAUTION

Indicates a potentially hazardous situation that, if not avoided, may result in minor or moderate injury.

IMPORTANT

Indicates that failure to observe can cause damage to equipment.

NOTE

Indicates helpful information.

WOODS®

ALITEC™

BMP®

CENTRAL FABRICATORS®

GANNON®

GILL®

WAIN-ROY®

WOODS®

TABLE OF CONTENTS

INTRODUCTION	Inside Front Cover
SPECIFICATIONS	2
GENERAL INFORMATION	2
SAFETY RULES	5
SAFETY DECALS	6
OPERATION	8
OWNER SERVICE	14
TROUBLE SHOOTING	18
DEALER SERVICE	20
ASSEMBLY	28
DEALER CHECK LIST	32
PARTS LISTS	33
BOLT TORQUE CHART	41
BOLT SIZE CHART & ABBREVIATIONS	42
INDEX	43
PRODUCT WARRANTY	44
REPLACEMENT PARTS WARRANTY	Inside Back Cover

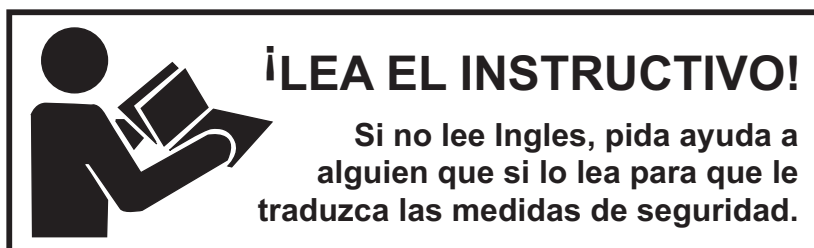

SPECIFICATIONS

	<u>RD6000-2</u>	<u>RD7200-2</u>	<u>RD8400-2</u>
3-Point Hitch	Category 1	Category 1	Category 1
Cutting Width	60"	72"	84"
Cutting Height Range	1" - 5-1/2"	1" - 5-1/2"	1" - 4-1/4"
Operating Weight with Chain Shielding	605 lbs	671 lbs	770 lbs
Blade Speed (feet per minute)	16,950	16,800	16,700
Blade Speed (RPM)	3,083	2,570	2,179

SAFETY RULES



ATTENTION! BECOME ALERT! YOUR SAFETY IS INVOLVED!



Safety is a primary concern in the design and manufacture of our products. Unfortunately, our efforts to provide safe equipment can be wiped out by an operator's single careless act.

In addition to the design and configuration of equipment, hazard control and accident prevention are dependent upon the awareness, concern, judgement, and proper training of personnel involved in the operation, transport, maintenance and storage of equipment.

It has been said "The best safety device is an informed, careful operator." We ask you to be that kind of operator.

TRAINING

- **Safety instructions are important! Read all attachment and power unit manuals; follow all safety rules and safety decal information. (Replacement manuals and safety decals are available from your dealer. To locate your nearest dealer, check the Dealer Locator at www.WoodsEquipment.com, or in the United States and Canada call 1-800-319-6637.) Failure to follow instructions or safety rules can result in serious injury or death.**
- **Know your controls and how to stop engine and attachment quickly in an emergency.**
- **If you do not understand any part of this manual and need assistance, see your dealer.**
- **Operators must be instructed in and be capable of the safe operation of the equipment, its attachments, and all controls. Do not allow anyone to operate this equipment without proper instructions.**
- **Never allow children or untrained persons to operate equipment.**

PREPARATION

- **Check that all hardware is properly installed. Always tighten to torque chart specifications unless instructed otherwise in this manual.**
- **Always wear relatively tight and belted clothing to avoid getting caught in moving parts. Wear sturdy, rough-soled work shoes and protective equipment for eyes, hair, hands, hearing, and head; and respirator or filter mask where appropriate.**
- **Make sure attachment is properly secured, adjusted, and in good operating condition.**

- **Make sure spring-activated locking pin or collar slides freely and is seated firmly in tractor PTO spline groove.**
- **Make sure driveline shield tether chains are attached to the tractor and equipment as shown in this manual. Replace if damaged or broken. Check that driveline guards rotate freely on driveline before putting equipment into service.**
- **Before starting power unit, check all equipment driveline guards for damage. Replace any damaged guards. Make sure all guards rotate freely on all drivelines. If guards do not rotate freely on drivelines, repair and replace bearings before putting equipment into service.**
- **Power unit must be equipped with ROPS or ROPS cab and seat belt. Keep seat belt securely fastened. Falling off power unit can result in death from being run over or crushed. Keep foldable ROPS system in "locked up" position at all times.**
- **Power unit must be equipped with ROPS or ROPS cab and seat belt. Keep seat belt securely fastened. Falling off power unit can result in death from being run over or crushed. Keep foldable ROPS system in "locked up" position at all times.**
- **Remove accumulated debris from this equipment, power unit, and engine to avoid fire hazard.**
- **Make sure all safety decals are installed. Replace if damaged. (See Safety Decals section for location.)**
- **Make sure shields and guards are properly installed and in good condition. Replace if damaged.**
- **A minimum 25% of tractor and equipment weight must be on the tractor front wheels when attachments are in transport position. Without this weight, tractor could tip over, causing personal injury or death. The weight may be attained with a loader. Weigh the tractor and equipment. Do not estimate.**

OPERATION

- **Inspect and clear area of stones, branches, or other hard objects that might be thrown, causing injury or damage.**
- **Full chain shielding, designed to reduce the possibility of thrown objects, must be installed when operating in populated areas or other areas where thrown objects could injure people or damage property. If this machine is not equipped with full chain shielding, operation must be stopped when anyone comes within several hundred feet.**

SAFETY RULES



ATTENTION! BECOME ALERT! YOUR SAFETY IS INVOLVED!



- Never direct discharge toward people, animals, or property.
- Keep bystanders away from equipment.
- Never go underneath equipment (lowered to the ground or raised) unless it is properly blocked and secured. Never place any part of the body underneath equipment or between moveable parts even when the engine has been turned off. Hydraulic system leak down, hydraulic system failures, mechanical failures, or movement of control levers can cause equipment to drop or rotate unexpectedly and cause severe injury or death. Follow Operator's Manual instructions for working underneath and blocking requirements or have work done by a qualified dealer.
- Do not operate or transport equipment while under the influence of alcohol or drugs.
- Operate only in daylight or good artificial light.
- Keep hands, feet, hair, and clothing away from equipment while engine is running. Stay clear of all moving parts.
- Always comply with all state and local lighting and marking requirements.
- Never allow riders on power unit or attachment.
- Always sit in power unit seat when operating controls or starting engine. Securely fasten seat belt, place transmission in neutral, engage brake, and ensure all other controls are disengaged before starting power unit engine.
- Operate tractor PTO at 540 RPM. Do not exceed.
- Look down and to the rear and make sure area is clear before operating in reverse.
- Do not operate or transport on steep slopes.
- Do not stop, start, or change directions suddenly on slopes.
- Use extreme care and reduce ground speed on slopes and rough terrain.
- Watch for hidden hazards on the terrain during operation.
- Stop power unit and implement immediately upon striking an obstruction. Dismount power unit, using proper procedure. Inspect and repair any damage before resuming operation.
- Before dismounting power unit or performing any service or maintenance, follow these steps: disengage power to equipment, lower the 3-point hitch and all raised components to the ground,

operate valve levers to release any hydraulic pressure, set parking brake, stop engine, remove key, and unfasten seat belt.

- Before working underneath, carefully read Operator's Manual instructions, disconnect driveline, raise mower, securely block up all corners with jackstands, and check stability. Secure blocking prevents equipment from dropping due to hydraulic leak down, hydraulic system failures, or mechanical component failures.

TRANSPORTATION

- Use additional caution and reduce speed when under adverse surface conditions, turning, or on inclines.
- Do not operate PTO during transport.
- A minimum 25% of tractor and equipment weight must be on the tractor front wheels when attachments are in transport position. Without this weight, tractor could tip over, causing personal injury or death. The weight may be attained with a loader. Weigh the tractor and equipment. Do not estimate.
- Do not operate or transport on steep slopes.
- Do not operate or transport equipment while under the influence of alcohol or drugs.
- Always comply with all state and local lighting and marking requirements.
- Never allow riders on power unit or attachment.

MAINTENANCE

- Before dismounting power unit or performing any service or maintenance, follow these steps: disengage power to equipment, lower the 3-point hitch and all raised components to the ground, operate valve levers to release any hydraulic pressure, set parking brake, stop engine, remove key, and unfasten seat belt.
- Before working underneath, carefully read Operator's Manual instructions, disconnect driveline, raise mower, securely block up all corners with jackstands, and check stability. Secure blocking prevents equipment from dropping due to hydraulic leak down, hydraulic system failures, or mechanical component failures.
- Do not modify or alter or permit anyone else to modify or alter the equipment or any of its components in any way.

SAFETY RULES



ATTENTION! BECOME ALERT! YOUR SAFETY IS INVOLVED!



- Always wear relatively tight and belted clothing to avoid getting caught in moving parts. Wear sturdy, rough-soled work shoes and protective equipment for eyes, hair, hands, hearing, and head; and respirator or filter mask where appropriate.
- Make sure attachment is properly secured, adjusted, and in good operating condition.
- Keep all persons away from operator control area while performing adjustments, service, or maintenance.
- Make certain all movement of equipment components has stopped before approaching for service.
- Never go underneath equipment (lowered to the ground or raised) unless it is properly blocked and secured. Never place any part of the body underneath equipment or between moveable parts even when the engine has been turned off. Hydraulic system leak down, hydraulic system failures, mechanical failures, or movement of control levers can cause equipment to drop or rotate unexpectedly and cause severe injury or death. Follow Operator's Manual instructions for working underneath and blocking requirements or have work done by a qualified dealer.
- Frequently check blades. They should be sharp, free of nicks and cracks, and securely fastened.

- Do not handle blades with bare hands. Careless or improper handling may result in serious injury.
- Your dealer can supply genuine replacement blades. Substitute blades may not meet original equipment specifications and may be dangerous.
- Tighten all bolts, nuts, and screws to torque chart specifications. Check that all cotter pins are installed securely to ensure equipment is in a safe condition before putting unit into service.
- Make sure all safety decals are installed. Replace if damaged. (See Safety Decals section for location.)
- Make sure shields and guards are properly installed and in good condition. Replace if damaged.
- Wear gloves when installing belt. Be careful to prevent fingers from being caught between belt and pulley.
- Use care when installing or removing belt from spring-loaded idler. Springs store energy when extended and, if released suddenly, can cause personal injury.

STORAGE

- Follow manual instructions for storage.
- Keep children and bystanders away from storage area.



DANGER

1 - 15503

DANGER

SHIELD MISSING

DO NOT OPERATE
PUT SHIELD ON

2 - 18867

18867-B

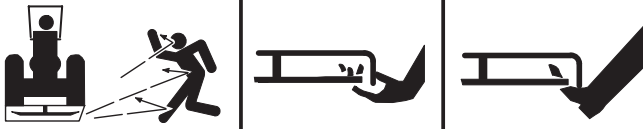

ROTATING BLADES AND THROWN OBJECTS

- Do not put hands or feet under or into mower when engine is running.
- Before mowing, clear area of objects that may be thrown by blade.
- Keep bystanders away.
- Keep guards in place and in good condition.

**BLADE CONTACT OR THROWN OBJECTS CAN
CAUSE SERIOUS INJURY OR DEATH.**

15503-C

3 - Serial Number Plate

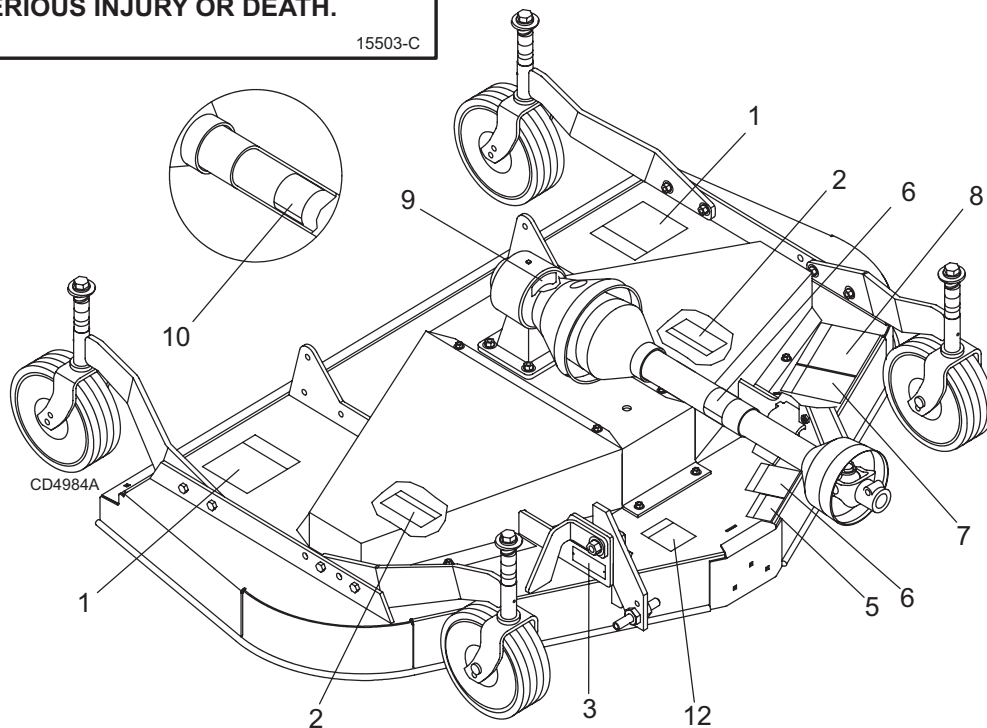

6 Safety

MAN0180 (Rev. 1/7/2005)

⚠ WARNING

**DO NOT EXCEED PTO SPEED OF
540 RPM**

PTO speeds higher than 540 RPM can cause
equipment failure and personal injury.

18866-D

5 - 18866

⚠ DANGER



**GUARD MISSING.
DO NOT OPERATE.**

⚠ DANGER



**GUARD MISSING.
DO NOT OPERATE.**

33347E

⚠ DANGER

OPERATION

The operator is responsible for the safe operation of the mower. The operator must be properly trained. Operators should be familiar with the mower, the tractor, and all safety practices before starting operation. Read the safety rules and safety decals on page 3 to 7.

This mower is designed for lawn and grass mowing. It is not designed for rough conditions or heavy weed mowing. It is equipped with suction type blades for best results in lawn mowing.

Recommended mowing speed for most conditions is from 2 to 5 mph.

DANGER

■ Full chain shielding, designed to reduce the possibility of thrown objects, must be installed when operating in populated areas or other areas where thrown objects could injure people or damage property. If this machine is not equipped with full chain shielding, operation must be stopped when anyone comes within several hundred feet.

■ Never allow children or untrained persons to operate equipment.

■ Keep bystanders away from equipment.

■ Make sure spring-activated locking pin or collar slides freely and is seated firmly in tractor PTO spline groove.

■ Operate tractor PTO at the RPM speed stated in "Specifications" section.

■ Before working underneath, carefully read Operator's Manual instructions, disconnect driveline, raise mower, securely block up all corners with jackstands, and check stability. Secure blocking prevents equipment from dropping due to hydraulic leak down, hydraulic system failures, or mechanical component failures.

■ Keep all persons away from operator control area while performing adjustments, service, or maintenance.

■ Stop power unit and implement immediately upon striking an obstruction. Dismount power unit, using proper procedure. Inspect and repair any damage before resuming operation.

■ Always wear relatively tight and belted clothing to avoid entanglement in moving parts. Wear sturdy, rough-soled work shoes and protective equipment for eyes, hair, hands, hearing, and head; and respirator or filter mask where appropriate.

TRACTOR STABILITY

■ A minimum 25% of tractor and equipment weight must be on the tractor front wheels when attachments are in transport position. Without this weight, tractor could tip over, causing personal injury or death. The weight may be attained with a loader. Weigh the tractor and equipment. Do not estimate.

Figure 1. Tractor Stability

ATTACHING MOWER TO TRACTOR

⚠ WARNING

- Make sure spring-activated locking pin or collar slides freely and is seated firmly in tractor PTO spline groove.

The standard 1-3/8" 6B-spline driveline with a QD yoke is used to connect the mower to the tractor.

1. Attach the mower hitch pins to the lower tractor lift arms and secure.
2. Attach tractor top link (1), Figure 2, to mower top link bracket attachment point A. Connect the driveline to the tractor PTO shaft.
3. Attach tether chain to tractor drawbar (Figure 3).
4. Adjust the tractor lower 3-point arm anti-sway devices to prevent mower from swinging side to side during transport.

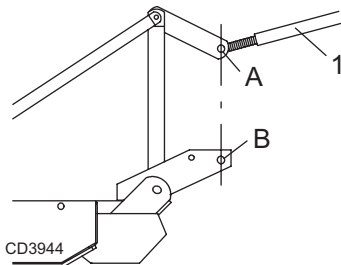

1. Tractor top link
- A. Mower top link attachment point
- B. Mower hitch pin

Figure 2. Attachment Points

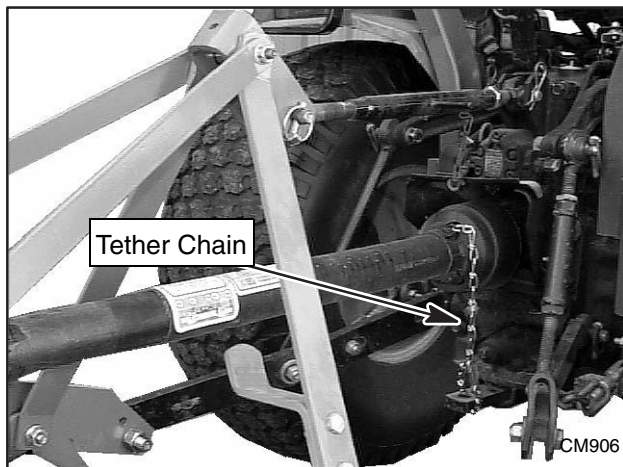

Figure 3. Attach Mower to Tractor

CUTTING HEIGHT ADJUSTMENT

⚠ WARNING

- Keep all persons away from operator control area while performing adjustments, service, or maintenance.

IMPORTANT

- Avoid low cutting heights. Striking the ground with blades produces one of the most damaging shock loads a mower can encounter. Allowing blades to contact ground repeatedly will cause damage to mower and drive.

1. Level mower from side to side. Check by measuring from mower frame to the ground at each deck rail.
2. Verify that the same amount of spacers are under all caster arms.
3. Loosen cap screws that attach caster arm assembly to deck.
4. Set mower on the ground.
5. Retighten cap screws. This equalizes the clearance in the bolt holes.
6. Adjust front of mower level with or slightly lower than the rear to obtain best mowing results.
7. Control cutting height by adjusting front and rear caster wheels.
8. To raise rear of mower, move caster adjustment spacers under rear caster arms, Figure 5.
9. To raise front of mower, move spacers under front caster wheel arms.

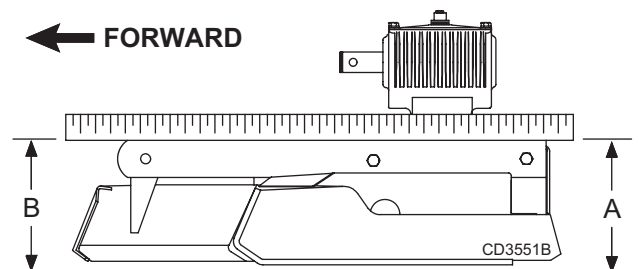

Figure 4. Cutting Height Adjustment

Remember, measurement at location A (Figure 4) should not be less than location B and should not be over 1/2" greater than location B.

et
ster

mounting
ould be higher

configurations for the
caster arms.

ows the outside edge of the
for trimming under shrubs or

tion provides the most clearance for
are interference.

WARRANTY

adjust tra
point A

shown.

38400-2 front caster arms are fixed and
cannot be changed.

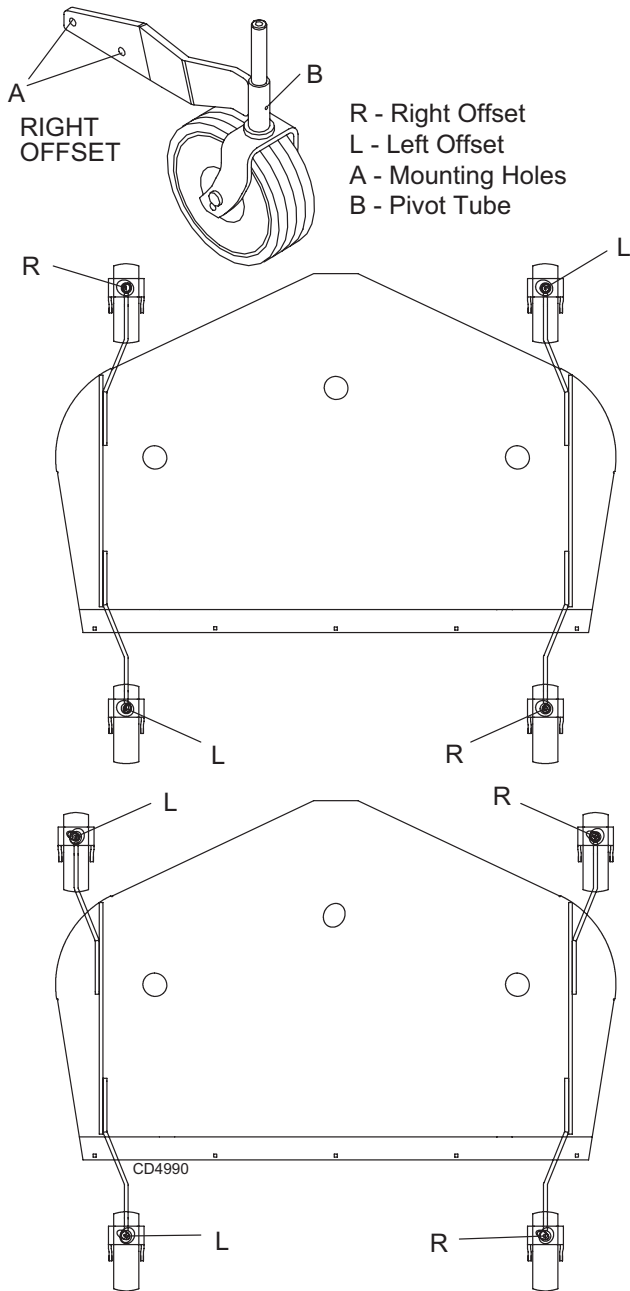

Figure 8. Front Caster Arm Configuration for RD6000-2 & RD7200-2 Only

FRONT CASTER WHEEL INTERFERENCE CHECK

IMPORTANT

■ Do not operate tractor and mower until this interference check has been performed. If you change tractors, you must perform the check for that mounting.

Perform this check with all of the spacers and springs above the caster wheel arm. This will place the caster

wheels in their highest position and provide the lowest cutting height for the mower.

1. Raise mower with tractor hydraulics to 16" at dimension C or maximum height of tractor lift, whichever is less.
2. Pivot both front caster wheels forward and check that there is clearance between caster wheels and tractor tires.
3. If there is interference on models RD6000-2 and RD7200-2, mount front casters in the outer position.

NOTE: On model RD8400-2, caster wheel width is not adjustable; see tractor operator's manual and adjust tractor wheels to narrower spacing.

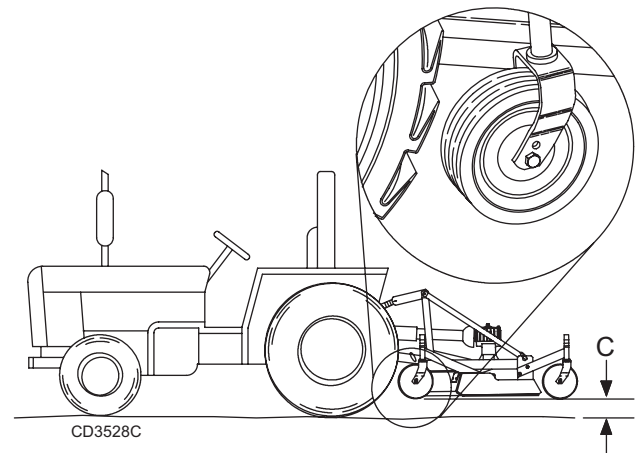

Figure 9. Front Gauge Wheel Interference Check

FRONT ROLLER (OPTIONAL)

The caster wheels and side skids effectively reduce scalping in most cases. However, you may encounter areas where the caster wheels and/or side skids drop into depressions and allow center of the mower to contact ground and scalp. An optional front roller may be installed to minimize scalping.

OPERATING TECHNIQUE

⚠ CAUTION

■ Stop power unit and implement immediately upon striking an obstruction. Dismount power unit, using proper procedure. Inspect and repair any damage before resuming operation.

Power for operating mower is supplied by tractor PTO. Operate PTO at 540 rpm. Know how to stop tractor and mower quickly in an emergency.

If mower becomes plugged causing belt to slip for over two seconds follow these steps:

1. Maneuver equipment into a previously cut area and allow mower to clear accumulated material.
2. Continue running at least two minutes, allowing pulleys to cool. Stopping the mower in contact with a very hot pulley will bake and ruin belt.

Proper ground speed will depend upon the terrain, the height, and type and density of material to be cut.

OWNER PRE-OPERATION CHECK LIST

(OWNER'S RESPONSIBILITY)

- ___ Review and follow all safety rules and safety decal instructions on pages 3 through 7.
- ___ Check that all safety decals are installed and in good condition. Replace if damaged.
- ___ Check that all shields and guards are properly installed and in good condition. Replace if damaged.
- ___ Check that chain shielding is in good condition and replace any damaged chain links.
- ___ Check that all hardware and cotter pins are properly installed and secured.
- ___ Check to ensure blades are sharp, in good condition, and installed correctly. Replace if damaged.
- ___ Check that equipment is properly and securely attached to tractor.
- ___ Make sure driveline spring-activated locking pin or collar slides freely and is seated firmly in tractor PTO spline groove.
- ___ Make sure the driveline guards and tether chains are in good condition. Guards must rotate freely on driveline. Fasten tether chains to the tractor and the equipment as instructed.
- ___ Inspect area and remove stones, branches or other hard objects that might be thrown, causing injury or damage.
- ___ Do not allow riders.
- ___ Check all lubrication points and grease as instructed in "Lubrication Information" on page 14. Make sure the PTO slip joint is lubricated and that the gearbox fluid levels are correct.
- ___ Set tractor PTO at correct rpm for your equipment.
- ___ Make sure tractor ROPS or ROPS cab and seat belt are in good condition. Keep seat belt securely fastened during operation.
- ___ Before starting engine, operator must be in tractor seat with seat belt fastened. Place transmission in neutral or park, engage brake, and disengage tractor PTO.

NOTES

OWNER SERVICE

The information in this section is written for operators who possess basic mechanical skills. If you need help, your dealer has trained service technicians available. For your protection, read and follow the safety information in this manual.

⚠ CAUTION

■ Always wear relatively tight and belted clothing to avoid entanglement in moving parts. Wear sturdy, rough-soled work shoes and protective equipment for eyes, hair, hands, hearing, and head; and respirator or filter mask where appropriate.

⚠ WARNING

■ Never allow children or untrained persons to operate equipment.

■ Keep bystanders away from equipment.

■ Before working underneath, carefully read Operator's Manual instructions, disconnect driveline, raise mower, securely block up all corners with jackstands, and check stability. Secure blocking prevents equipment from dropping due to hydraulic leak down, hydraulic system failures, or mechanical component failures.

■ Keep all persons away from operator control area while performing adjustments, service, or maintenance.

■ Operate tractor PTO at the RPM speed stated in "Specifications" section.

BLOCKING METHOD

Do not work underneath mower unless it is properly attached to the tractor and blocked securely. When properly attached, the unit will be anchored to minimize front to rear movement.

Raise mower completely, set tractor brakes, turn engine off, remove key, block tractor wheels front and rear, and disconnect mower driveline from tractor.

The only approved blocking device for this mower is a jackstand with a load rating of 1000 pounds or more. One jackstand under each corner of the mower (four total) must be installed before working underneath this unit.

Install jackstands under each corner of the mower.

When blocking, you must consider overall stability of the unit. Just blocking under the unit will not ensure your safety. The working surface must be level and solid to support the loaded weight of the jackstands. Test jackstands stability before working under any portion of the mower.

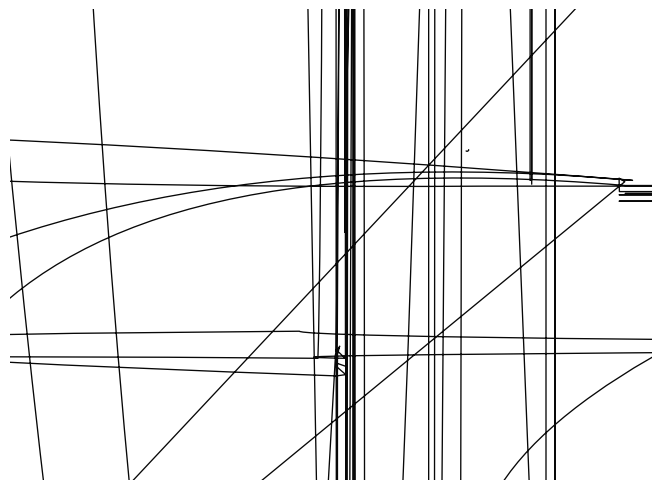

Figure 11. Blocking Method

LUBRICATION INFORMATION

Do not let excess grease collect on or around parts, particularly when operating in sandy areas.

Figure 12 shows the lubrication points. The accompanying chart gives the frequency of lubrication in operating hours, based on normal operating conditions.

Severe or unusual conditions may require more frequent lubrication. Some reference numbers have more than one location; be sure you lubricate all locations.

Use a lithium grease of #2 consistency with a MOLY (molybdenum disulfide) additive for all locations. Be sure to clean fittings thoroughly before attaching grease gun. When applied according to the lubrication chart, one good pump of most guns is sufficient.

Use SAE 90W gear lube in the gearbox. Fill to plug on side of gearbox.

Check gearbox daily for evidence of leakage at both seals and the gasket between the housing and cover. If leakage is noted, repair immediately. There may be a small amount of lube emitted from the vent plug; this is not considered leakage.

Overfilling the gearbox will cause the excess gear lube to blow out vent plug and ruin the belt.

Driveshaft Lubrication

Lubricate the driveshaft slip joint every 8 operating hours. Failure to maintain proper lubrication could result in damage to U-joints, gearbox, and driveshaft.

1. Lower mower to ground.
2. Apply grease at three locations as shown in Figure 12.
3. Raise and lower mower several times to distribute grease.

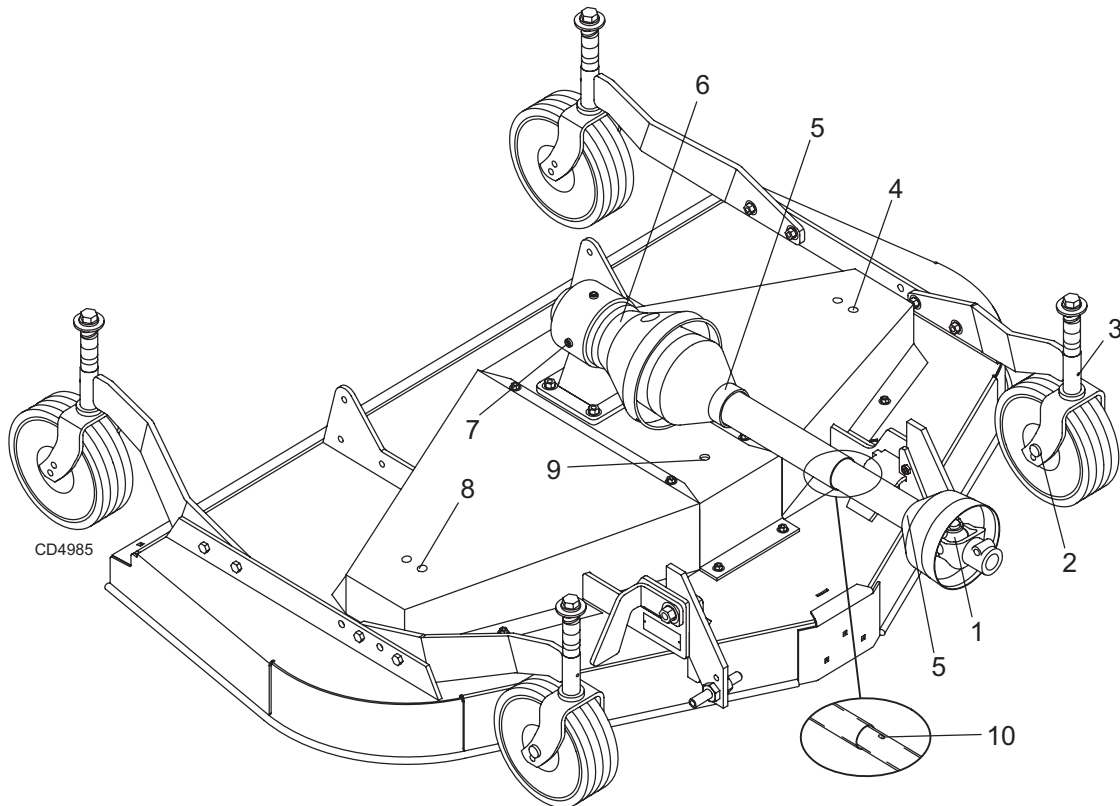

Figure 12. Lubrication Points & Chart

REF	DESCRIPTION	FREQUENCY
<u>1</u>	Front U-Joint	8 Hours
<u>2</u>	Caster Wheel (Four wheels)	8 Hours
<u>3</u>	Caster Pivot (Four wheels)	8 Hours
<u>4</u>	Left Spindle (Access through hole)	24 Hours
<u>5</u>	Shield Bearings	8 Hours
<u>6</u>	Rear U-Joint	8 Hours
<u>7</u>	Gearbox (Fill to center of horizontal shaft with SAE 90W gear lube)	Check Daily
<u>8</u>	Right Spindle (Access through hole)	24 Hours
<u>9</u>	Center Spindle (Access through hole)	24 Hours
<u>10</u>	Slip Joints (3 Sides)	8 Hours

BELT SERVICE

Belt Replacement

One of the major causes of belt failure is improper installation. Before installing a new belt, check the following:

1. Check pulley shafts and bearings for wear.
2. Check pulley grooves for cleanliness.
3. Make sure spindles turn freely and without wobble.

If grooves require cleaning, moisten a cloth with a non-flammable, non-toxic degreasing agent or commercial detergent and water.

Avoid excessive force during installation. Do not use tools to pry belt into pulley groove. Do not roll belt over pulleys to install. This can cause hidden damage and premature belt failure.

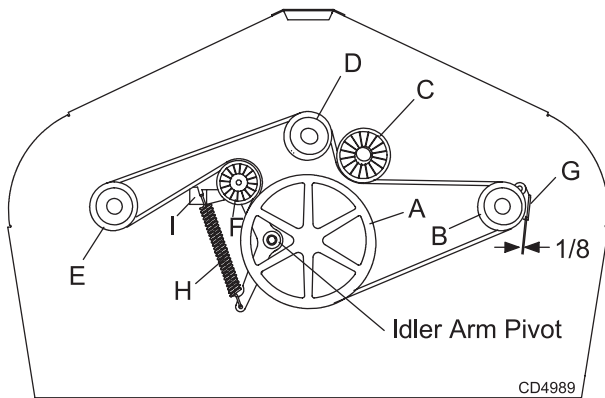

Figure 13. Belt Routing

Belt Installation

Refer to Figure 13.

1. Disconnect idler spring from deck lug I.
2. Slide belt under drive pulley A and over idler arm. Position belt around drive pulley A.
3. Loosen bolt holding belt guide G and swing it away from pulley B. Route belt around pulley B, idler C and pulley D as shown.
4. Make sure belt is on drive pulley A, route around idler F, and connect idler spring to lug I on deck.
5. Grasp belt between spindle pulley E, spring loaded idler F and spindle pulley D. Pull spring loaded idler with belt to obtain enough belt length to route it over pulley E. Make sure spring-loaded idler pivots freely with belt installed.

IMPORTANT

■ Use care when installing or removing belt from spring-loaded idler at step 5. Springs store energy when extended and, if released suddenly, can cause personal injury.

6. Adjust belt guide G to provide 1/16" to 1/8" clearance from belt. Tighten bolt to 85 lb.-ft.

BLADE SERVICE

⚠ WARNING

■ Before dismounting power unit or performing any service or maintenance, follow these steps: disengage power to equipment, lower the 3-point hitch and all raised components to the ground, operate valve levers to release any hydraulic pressure, set parking brake, stop engine, remove key, and unfasten seat belt.

■ Keep all persons away from operator control area while performing adjustments, service, or maintenance.

Blade Installation

⚠ CAUTION

■ Your dealer can supply genuine replacement blades. Substitute blades may not meet original equipment specifications and may be dangerous.

1. Place cap screws (3) through outer holes in blade and spindle shaft.
2. Make sure blade cutting edge is positioned to lead in a clockwise rotation, as viewed from top of mower.
3. Place locknuts (4) on screws, torque to 84 lbs-ft.

Figure 14. Blade Assembly

Blade Sharpening

IMPORTANT

■ When sharpening blades, be sure to balance them. Unbalanced blades will cause excessive vibration which can damage blade spindle bearings. Vibration may also cause structural cracks in mower components.

1. Remove blades.
2. Always sharpen both ends at the same time to maintain balance.
3. Follow original sharpening pattern.
4. Do not sharpen blade to a razor edge. Leave from 1/32" to 1/16" blunt edge.
5. Do not sharpen back side.

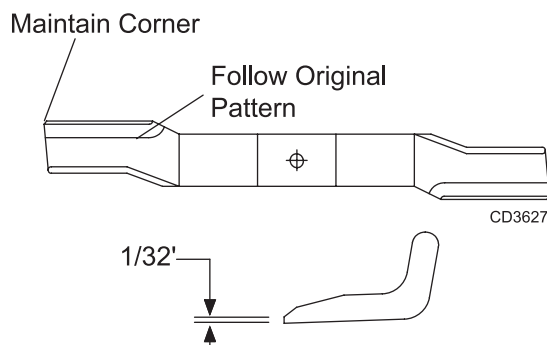

Figure 15. Blade Sharpening

CHAIN SHIELDING

⚠ DANGER

■ Full chain, rubber, curtain, or belt shielding, designed to reduce the possibility of thrown objects, must be installed when operating in populated areas or other areas where thrown objects

could injure people or damage property. If this machine is not equipped with full chain, rubber, curtain, or belt shielding, operation must be stopped when anyone comes within several hundred feet.

Check that chain shielding is in good condition and replace any damaged chain links.

CLEANING

After Each Use

- Remove large debris such as clumps of dirt, grass, crop residue, etc. from machine.
- Inspect machine and replace worn or damaged parts.
- Replace any safety decals that are missing or not readable.

Periodically or Before Extended Storage

- Clean large debris such as clumps of dirt, grass, crop residue, etc. from machine.
- Remove the remainder using a low-pressure water spray.
 1. Be careful when spraying near scratched or torn safety decals or near edges of decals as water spray can peel decal off surface.
 2. Be careful when spraying near chipped or scratched paint as water spray can lift paint.
 3. If a pressure washer is used, follow the advice of the pressure washer manufacturer.
- Inspect machine and replace worn or damaged parts.
- Sand down scratches and the edges of areas of missing paint and coat with Woods spray paint of matching color (purchase from your Woods dealer).
- Replace any safety decals that are missing or not readable (supplied free by your Woods dealer). See Safety Decals section for location drawing.

TROUBLE SHOOTING

MOWING CONDITIONS

PROBLEM	POSSIBLE CAUSE	SOLUTION
Grass cut higher in center of swath than at edge	Height of mower higher at front than at rear	Adjust mower height and attitude so that mower rear and front are within 1/2 inch of same height. See instructions on page 9.
	Loose Blade	Check blade hardware.
Grass cut lower in center of swath than at edge	Height of mower lower at front than at rear	Adjust mower height and attitude so that mower rear and front are within 1/2 inch of same height. See instructions on page 9.
	Loose Blade	Check blade hardware
Streaking conditions in swath	Conditions too wet for mowing	Allow grass to dry before mowing.
	Blades unable to cut that part of grass pressed down by path of tractor tires	Slow ground speed of tractor but keep engine running at full PTO rpm. Cutting lower will help. Adjust tractor tire spacing if possible.
	Dull blades	Sharpen or replace blades.
Material discharges from mower unevenly; bunches of material along swath	Material too high and too much material	Reduce ground speed but maintain 540 rpm at tractor PTO, or make two passes over material. Raise mower for the first pass and lower for the second and cut 90 degrees to first pass. Raise rear of mower high enough to permit material discharge, but not so high that conditions listed above occur.
	Grass wet	Allow grass to dry before mowing. Slow ground speed of tractor but keep engine running at full PTO rpm.

TROUBLE SHOOTING

BELT CONDITIONS

PROBLEM	POSSIBLE CAUSE	SOLUTION
Belt slippage	Mower overloading; Material too tall or heavy	Reduce tractor ground speed but maintain full PTO rpm. Cut material twice, one high pass and then mow at desired height. Cut 90 degrees to first pass.
	Oil on belt from over lubrication	Be careful not to over lubricate. Clean lubricant from belt and pulleys with clean rag. Replace oil-soaked belt.
	Belt hung up or rubbing	Check belt position in pulleys and idlers. Check belt for free travel in pulleys. Check under mower and around blade spindle shaft for wire, rags, or other foreign material. Clean all material from under mower.
Frayed edges on belt cover	Belt misaligned	Re-align belt. Be sure belt does not rub any other part while running.
	Pulley misaligned	Inspect to ensure belt is running in center of backside idler. Shim idler as necessary to align.
Belt rollover	Pulley misaligned	Re-align.
	Damaged belt	Replace belt*.
	Foreign object in pulley groove	Inspect all pulley grooves for rust, paint, or weld spots and remove.
	Worn pulley groove	Replace pulley.
Damaged belt	Rollover, high shock loads or installation damaged	Replace belt*.
Belt breakage	High shock loads	Avoid abusive mowing. Avoid hitting the ground or large obstructions.
	Belt came off drive	Check pulleys for foreign material in grooves. Avoid hitting solid objects or ground.

* Check belt for damage by laying it flat on the floor. A belt that does not lie flat (has humps or twists, indicating broken or stretched cords) must be replaced.

DEALER SERVICE

The information in this section is written for dealer service personnel. The repair described here requires special skills and tools. If your shop is not properly equipped or your mechanics are not properly trained in this type of repair, you may be time and money ahead to replace complete assemblies.

WARNING

■ Before working underneath, read manual instructions, securely block up, and check stability. Secure blocking prevents equipment from dropping due to hydraulic leak down, hydraulic system failure, or mechanical component failure.

■ Keep all persons away from operator control area while performing adjustments, service, or maintenance.

CAUTION

■ Always wear relatively tight and belted clothing to avoid entanglement in moving parts. Wear sturdy, rough-soled work shoes and protective equipment for eyes, hair, hands, hearing, and head; and respirator or filter mask where appropriate.

BLOCKING METHOD

Do not work underneath mower unless it is properly attached to the tractor and blocked securely. When properly attached, the unit will be anchored to minimize front to rear movement.

Raise mower completely, set tractor brakes, turn engine off, remove key, block tractor wheels front and rear, and disconnect mower driveline from tractor.

The only approved blocking device for this mower is a jackstand with a load rating of 1000 pounds or more. One jackstands under each corner of the mower (four total) must be installed before working underneath this unit.

Install jackstands under each corner of the mower.

When blocking, you must consider overall stability of the unit. Just blocking under the unit will not ensure your safety. The working surface must be level and solid to support the loaded weight of the jackstands. Test jackstands stability before working under any portion of the mower.

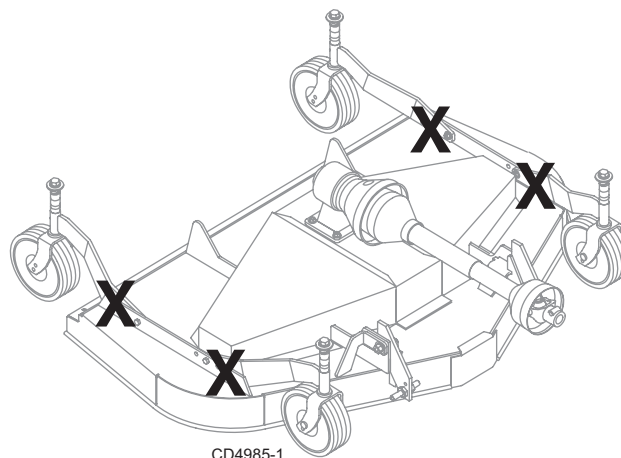

Figure 16. Blocking Method

BLADE SPINDLE SERVICE

Spindle repair requires special skills and tools. If your shop is not properly equipped or your mechanics are not trained in this type of repair, you may be time and money ahead to use a new spindle assembly.

For reference, the grease fitting is in the top of the spindle shaft.

Permatex^{®1} 3D Aviation Form-A-Gasket or equivalent is recommended as a sealant.

Spindle Removal

1. Remove blade from spindle.
2. Remove belt from pulleys.
3. Remove jam nut (1) and washer (3) from top of spindle shaft.
4. Disassemble split taper bushing (5) (located on top of pulley) by removing the two bolts (2) and washers (4).
5. Insert bolts (2) into the threaded holes of bushing flange.
6. Tighten bolts alternately to remove split taper bushing.
7. Remove pulley (6).
8. Remove bolts (19) that attach spindle to mower frame and remove spindle.
9. Remove grease fitting (21) from top of shaft.

1. Permatex is a registered trademark of the Permatex Corporation.

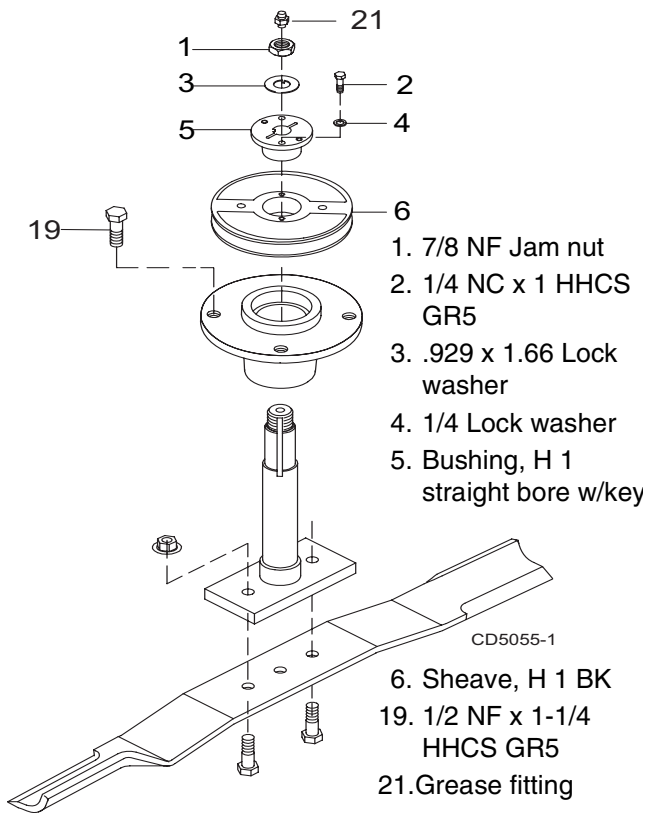

Figure 17. Sheave and Blade Assembly

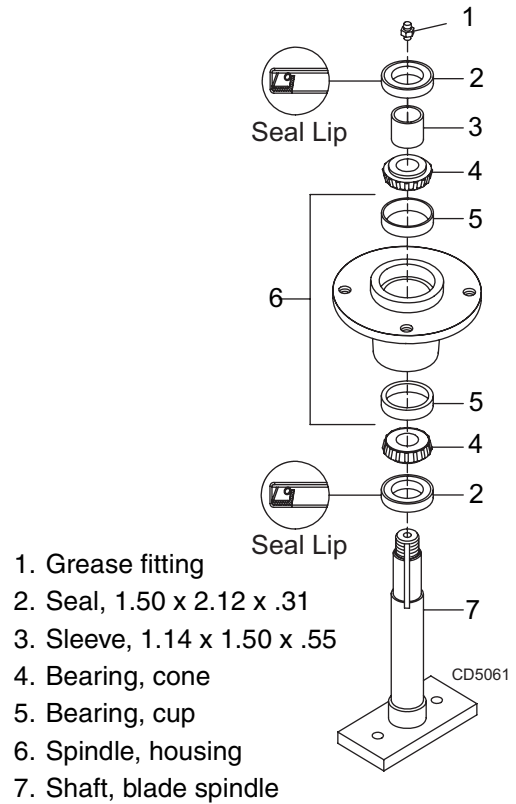

Figure 18. Spindle and Shaft Assembly

Spindle Disassembly

1. Place spindle assembly in press and press shaft down through housing.
2. Remove seals from housing.

Spindle Assembly

Refer to Figure 18.

Bearing cones and cups are designed to work together. It is important to position them so bearing cone taper mates with cup taper.

1. Lubricate new cups with a light oil. Place them in spindle housing so they will mate with bearing cones. Cups and cones are a press fit to minimize wear.

Seat cups securely with a press or place a large drift in the flat lip and drive them into housing until cup seats against machined shoulder of housing.

Remove bearing cups from housing by placing a punch in the slots provided and driving them out. Alternate punch positions from side to side. Take care to prevent housing damage.

2. Place bottom bearing cone into spindle with taper positioned to mate with cup.

IMPORTANT

■ **Improper positioning of seals can cause seal damage. An improperly installed seal will leak and could cause bearing failure.**

3. Identify the open side of the seal containing the spring.
4. Apply a thin coat of Permatex to the area of housing where seals seat.
5. Install bottom seal with spring up toward center of housing.
6. Place seal squarely on housing and select a piece of pipe or tubing with an OD that will set on outside edge of seal. A tubing with an OD that is too small will bow seal cage.
7. Carefully press seal into housing, to prevent distortion to metal seal cage. Bottom seal should seat firmly and squarely against machined shoulder in housing.
8. Make sure seal lip did not roll under. Distortion to seal cage or damage to seal lip will cause seal to leak. Damaged seals must be replaced.
9. Insert shaft and bearing through bottom of housing.
10. Fill housing cavity with a medium grade grease.
11. Install top bearing on shaft to mate with top cone.

Refer to Figure 19.

12. Apply a thin coat of Permatex to shaft area where sleeve will seat.
13. Install sleeve on shaft and press sleeve and bearing into housing until all free play is removed and there is a very light drag on bearings (similar to adjusting front wheel bearings on an automobile). Check by spinning spindle. It should turn freely.
14. Be careful not to overtighten bearings. Proper bearing adjustment is essential to good bearing life.
15. If you overtighten bearings, hold spindle housing and rap spindle shaft with a lead hammer.
16. Carefully press top seal in with spring up. Top seal should be flush with or to within 1/16" above the housing.
17. Rotate housing on spindle shaft, checking for free movement.
18. Install grease fitting in spindle shaft.

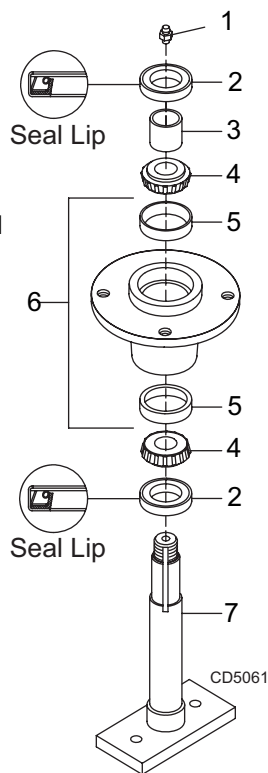

Figure 19. Spindle & Shaft Assembly

Spindle Installation

IMPORTANT

■ Pulley installation sequence is very important for bearing life. Follow the sequence exactly.

1. Install spindle through bottom of mower and secure with four mounting bolts.

2. Install pulley and split taper bushing with integral key on spindle shaft. Make sure bushing is in contact with sleeve on spindle shaft.
3. Alternately tighten split taper bushing cap screws to 12 lbs-ft.
4. Install toothed lock washer and nut on spindle shaft. Tighten nut until snug. Bend up edge of lock washer against a flat side on nut.

GEARBOX REPAIR

Read this entire section before starting any repair. Many steps are dependent on each other.

Fill gearbox with SAE 80W or 90W gear lube until it runs out the side level plug.

Repair to this gearbox is limited to replacing bearings, seals, and gaskets. Replacing gears, shafts, and a housing is not cost effective. It is more economical to purchase a complete gearbox if repair to anything other than replacement of bearings, seals or gaskets is required.

Inspect gearbox for leakage and bad bearings.

Leakage is a very serious problem and must be corrected immediately.

Bearing failure is indicated by excessive noise and side to side or end play in gear shafts.

Seal Replacement

Recommended sealant for gearbox repair is Permatex® Aviation 3D Form-A-Gasket or equivalent.

Leakage can occur at the vertical or horizontal gaskets and shaft seals.

Leakage at the horizontal gasket or seal can be repaired without removing the gearbox from the cutter.

Seal Installation

NOTE: Proper seal installation is important. An improperly installed seal will leak.

1. Clean area in housing where seal outer diameter (OD) seats. Apply a thin coat of Permatex.
2. Inspect area of shaft where seal seats. Remove any burrs or nicks with an emery cloth.
3. Lubricate gear shaft and seal lips.
4. Place seal squarely on housing, spring-loaded lip toward housing. Select a piece of pipe or tubing with an OD that will sit on the outside edge of the seal but will clear the housing. Tubing with an OD that is too small will bow seal cage and ruin seal.
5. Carefully press seal into housing, avoiding distortion to the metal seal cage.

- 
1. Crown gear
 2. Gearbox housing
 3. Input shaft
 4. Output shaft
 5. Gear pinion
 6. Bearing
 7. Bearing
 8. Protective flat washer
 9. Cotter pin
 10. Snap ring
 11. Snap ring
 12. Spacer
 13. Shim kit
 14. Castle nut
 15. Castle nut M24 x 2
 16. Shim kit
 17. Flat washer
 18. Oil seal (40 x 80 x 12)
 19. Oil seal (35 x 72 x 10)
 20. Cap
 21. Snap ring
 22. Top cover
 23. Bolt M8 x 14mm
 24. Breather level plug
 25. Cotter pin
 26. Bearing
 27. Ball bearing

Remove Gearbox from Mower

Refer to Figure 22.

1. Disconnect and remove the rear driveline from the gearbox.
2. Remove vent plug and siphon gear lube from housing through this opening.
3. Remove gearbox stand (20) from mower deck by removing four flanged lock nuts (56).
4. Remove four cap screws (43) and washers (42) and remove shield (22) from gearbox.
5. Remove castle nut and hardware from output shaft of gearbox.
6. Remove sheave (19) from gearbox.
7. Remove four bolts (63) that attach gearbox to gearbox stand and remove gearbox.

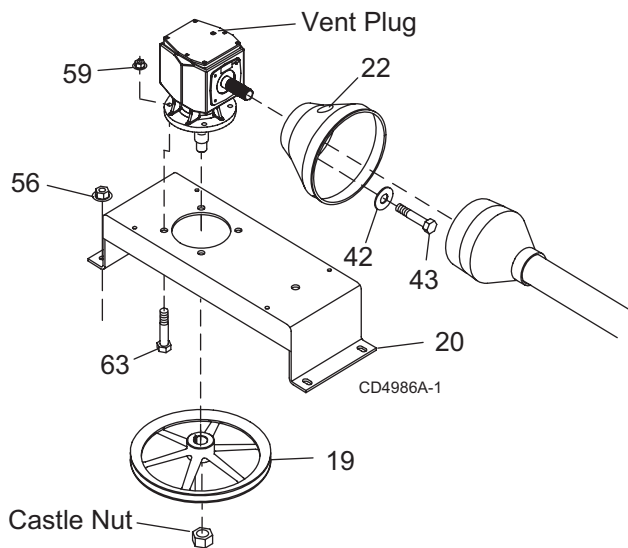

19. Sheave, offset 12.4 PD
20. Gearbox stand
22. Shield, counter cone
42. Washer, flat standard 5/16
43. Screw, HHCS 8mm x 1.25P x 16mm
56. Nut, flanged lock 1/2 NC
59. Nut, flanged lock 5/8 NC
63. Screw, Flanged Hex Head 5/8 NC x 1-3/4

Figure 22. Gearbox Stand Assembly

Disassemble Gearbox

1. Remove top cover (22) from housing. Turn gearbox upside down and pour out remaining gear oil from gearbox.
2. Remove oil cap (20) (to be replaced).
3. Remove snap ring (10) and shim (13) from input shaft (3).
4. Support gearbox in hand press and push on input shaft (3) to remove bearing (7).

5. Remove gear (1) from inside housing.
6. Remove oil seal (19) from front of housing (to be replaced).
7. Remove snap ring (10) and shim (13) from front of housing (2).
8. Remove input bearing (7) by using a punch and hammer from outside of housing.
9. Support housing in vise in a horizontal position.
10. The castle nut (15) and cotter pin (25) are already removed with the drive sheave. Remove the snap ring (21), washer (8), and seal (18).
11. Remove cotter pin (9), castle nut (14), and washer (17) from output shaft (4).
12. Remove output shaft (4) by using a punch and hammer and tap on top to drive down.
13. Remove gear (5) and shim (16) from inside housing.
14. Remove bearing (26) by using a punch and hammer from the top, outside the housing.
15. Support housing upside down (top cover surface) and remove bearing (6) by using a punch and hammer from the bottom side of the housing.
16. Inspect gears for broken teeth and wear. Some wear is normal and will show on loaded side. Forged gear surfaces are rough when new. Check that wear pattern is smooth.
17. Inspect vertical and horizontal shafts for grooves, nicks, or bumps in the areas where the seals seat. Resurface any damage with emery cloth.
18. Inspect housing and caps for cracks or other damage.

Reassemble Gearbox

Refer to Figure 23

NOTE: Repair to this gearbox is limited to replacing bearings, seals, and gaskets. Replacing gears, shafts, and a housing is not cost effective. Purchasing a complete gearbox is more economical.

1. Clean housing, paying specific attention to areas where gaskets will be installed.
2. Wash housing and all components thoroughly. Select a clean area for gearbox assembly. Replace all seals, bearings, and gaskets. All parts must be clean and lightly oiled before reassembling.
3. Insert output bearings (6 & 26) in the housing, using a round tube of the correct diameter and a hand press.
4. Slide output shaft (4) through both bearings (6 & 26) until it rests against bearing (6).
5. Slide shim (16) over output shaft (4).

6. Press gear (5) onto output shaft (4) and secure with washer (17), castle nut (14), and cotter pin (9).
7. Apply grease to lower seal lips (18) and press seal over output shaft (4), using a tube of the correct diameter. Be sure not to damage the seal lip. Press in housing so that seal is recessed.
8. Insert protective washer (8) by hand. Install snap ring (21) and position it together with dual lip seal (18) by pressing it into position. Verify that snap ring is seated correctly.
9. Press bearing (7) into the housing, using a round tube of the correct diameter and a hand press. Secure with shim (13) and snap ring (10).
10. Secure snap ring (11) on input shaft (3) if not already seated.
11. Place gear (1) through top of housing and align gear (1) and gear (5) so that gear teeth are aligned.
12. To hold gear (1) in place, slide input shaft (3) through gear (1) and bearing (7). Align splines on input shaft (3) and gear (1).
13. Slide spacer (12) over input shaft (3) and press bearing onto input shaft (3), using a round tube of the correct diameter and a hand press.
14. Slide shim (15) over input shaft (3) and secure with snap ring (10).
15. Check input shaft end float by moving the input shaft (3) by hand. If end float is higher than 0.012", insert shim between input shaft (3) and rear bearing (7). Repeat until end float is less than 0.012". Check rotational torque by hand. The torque should be less than 2.2 lbs.-inch.
16. Check that the gear backlash is between 0.006" and 0.016". You should not have to adjust the backlash.
17. Press in input oil seal (19), using tube of correct diameter. Be careful not to damage seal lip.
18. Press oil cap (20) on to cover the rear of housing, using a tube of the correct diameter.
19. Check gearbox housing for leaks by plugging all holes except one. Apply 4 psi compressed air and immerse the gearbox in water to verify that there are no leaks.
20. Remove gearbox from water and dry off with compressed air. Add SAE 80W or 90W EP oil until it runs out of side level hole. Tighten all plugs.

Install Gearbox

NOTE: Gearbox is heavy: do not attempt to move without mechanical assistance.

1. Set gearbox on gearbox stand and fasten with bolts and nuts. Torque bolts to 175 lbs-ft.
2. Attach drive sheave to output shaft. Secure using castle nut and hardware previously removed.
3. Attach gearbox stand to mower using four flanged lock nuts.

Install Drive Sheave

1. When gear stand is installed on mower, dimension A (from the top of the mower deck to the center line of the drive pulley) must be 2-7/16" ($\pm 1/32$ "). This is a critical dimension and must be carefully adjusted for proper belt life. Add or subtract shim washers under idler pulley to align with drive pulley.
2. Tighten gear stand hardware.
3. Fill gearbox half full with SAE 90W gear lube.
4. Check level after waiting five minutes to permit lube to work through bearings. Add lube, if necessary, until gearbox is half full.
5. Replace driveline shield. Attach driveline to gearbox.

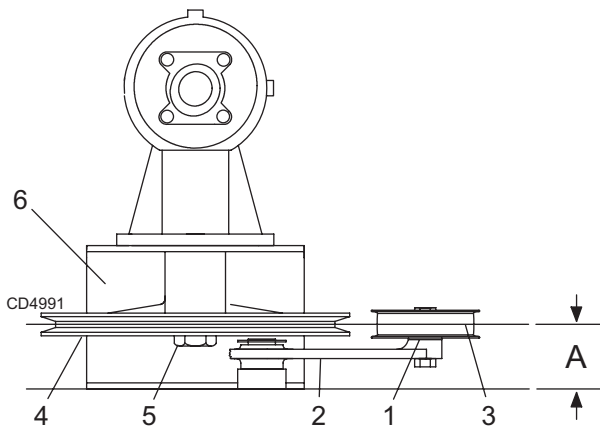

1. Shim
2. Idler arm
3. Idler pulley
4. Drive sheave
5. Castle nut & cotter pin
6. Gearbox stand

Figure 24. Drive Sheave Installation

UNIVERSAL JOINT REPAIR

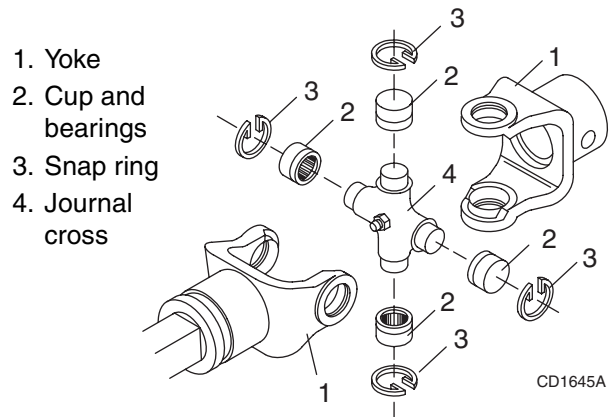

Figure 25. U-Joint Exploded View

U-Joint Disassembly

1. Remove external snap rings from yokes in four locations as shown in Figure 26.

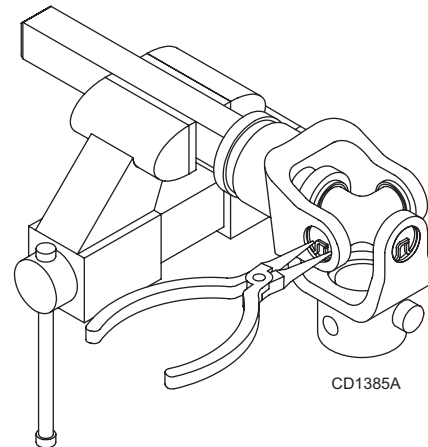

Figure 26

2. With snap rings removed, support drive in vise, hold yoke in hand and tap on yoke to drive cup up out of yoke. See Figure 27.

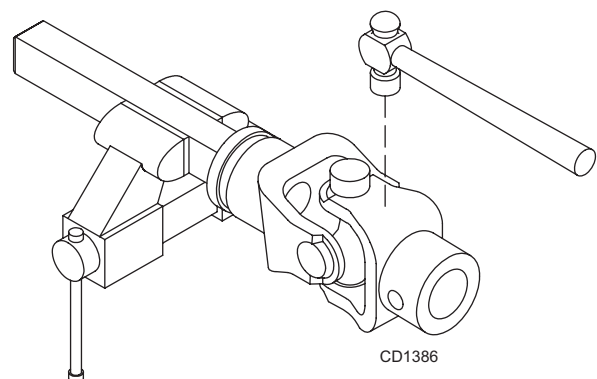

Figure 27

3. Clamp cup in vise as shown in Figure 28 and tap on yoke to completely remove cup from yoke. Repeat Step 2 and Step 3 for opposite cup.

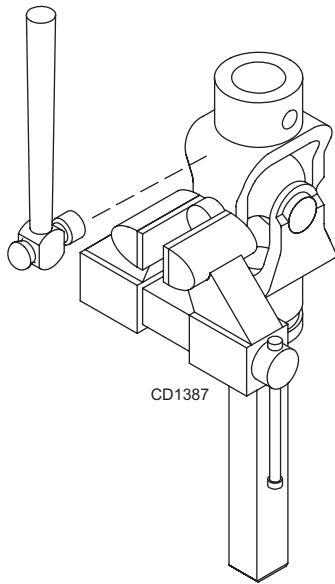

Figure 28

4. Place universal cross in vise as shown in Figure 29 and tap on yoke to remove cup. Repeat Step 3 for final removal. Drive remaining cup out with a drift and hammer.

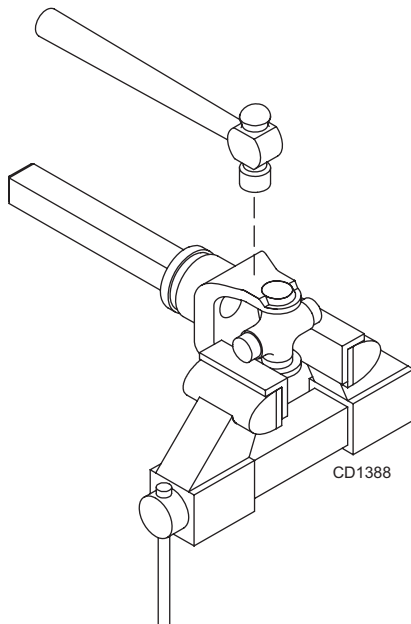

Figure 29

U-Joint Assembly

1. Place seals securely on bearing cups. Insert cup into yoke from outside and press in with hand pressure as far as possible. Insert journal cross into bearing cup with grease fitting away from shaft. Be careful not to disturb needle bearings. Insert another bearing cup directly across from first cup and press in as far as possible with hand pressure.
2. Trap cups in vise and apply pressure. Be sure journal cross is started into bearings and continue pressure with vise, squeezing in as far as possible. Tapping the yoke will help.
3. Seat cups by placing a drift or socket (slightly smaller than the cup) on cup and rap with a hammer. See Figure 30. Install snap ring and repeat on opposite cup.
4. Repeat Step 1 & Step 2 to install remaining cups in remaining yoke.
5. Move both yokes in all directions to check for free movement. If movement is restricted, rap on yokes sharply with a hammer to relieve any tension. Repeat until both yokes move in all directions without restriction.

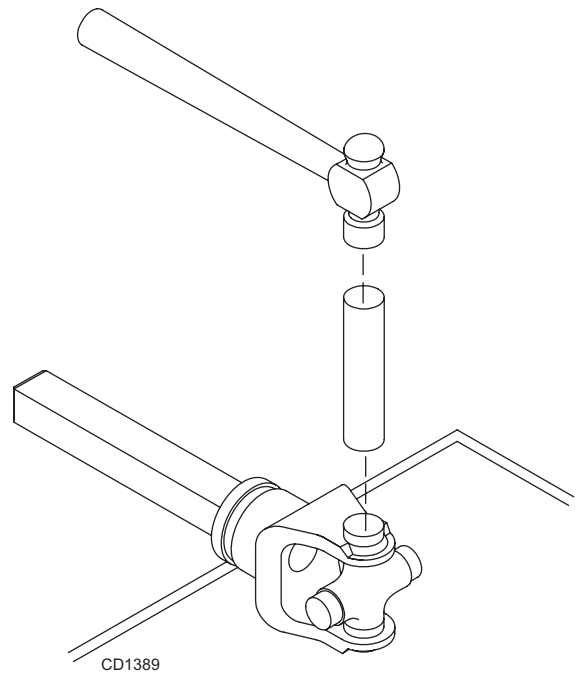

Figure 30

ASSEMBLY INSTRUCTIONS

DEALER SET-UP INSTRUCTIONS

Assembly of this mower is the responsibility of the Woods dealer. It should be delivered to the owner completely assembled, lubricated, and adjusted for normal cutting conditions.

Complete Dealer Check Lists on page 32 when you have completed the assembly.

The mower is shipped partially assembled. Assembly will be easier if components are aligned and loosely assembled before tightening hardware. Recommended torque values for hardware are located on page 41.

Select a suitable working area. Open parts boxes and lay out parts and hardware to make location easy. Refer to illustrations, accompanying text, parts lists and exploded view drawings.

WARNING

■ **Before working underneath, carefully read Operator's Manual instructions, disconnect driveline, raise mower, securely block up all corners with jackstands, and check stability. Secure blocking prevents equipment from dropping due to hydraulic leak down, hydraulic system failures, or mechanical component failures.**

CAUTION

■ **Always wear relatively tight and belted clothing to avoid entanglement in moving parts. Wear sturdy, rough-soled work shoes and protective equipment for eyes, hair, hands, hearing, and head; and respirator or filter mask where appropriate.**

Uncrate Mower

1. Remove sides and top of mower shipping crate.
2. Remove lag screws and brackets that secure mower to crate base.
3. Remove driveshaft wired to mower deck.



Figure 31 Uncrate Mower

Install Front Offset Links

1. Loosen lock nuts at lower hitch point and install offset link as shown.
2. Tighten nut securely.
3. Repeat for opposite side.

NOTE: Front link with the PTO storage bracket should be installed on right side of mower as shown in Figure 32.

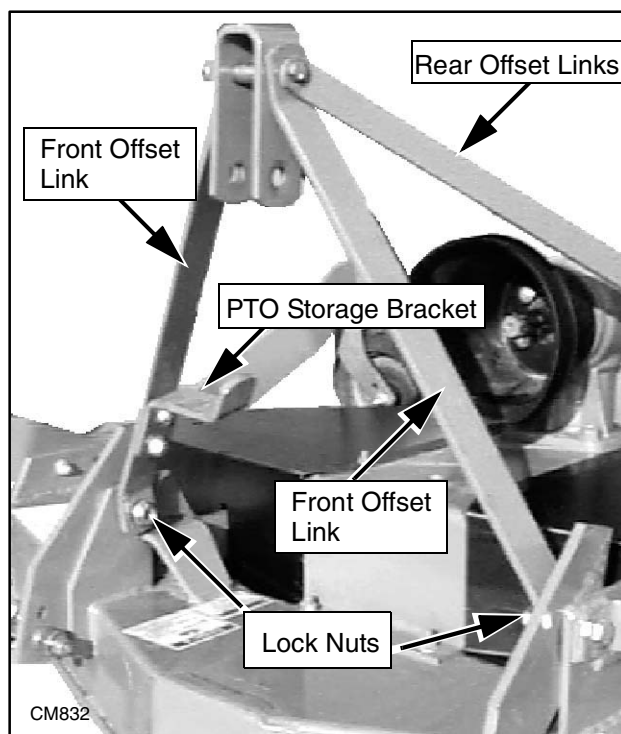
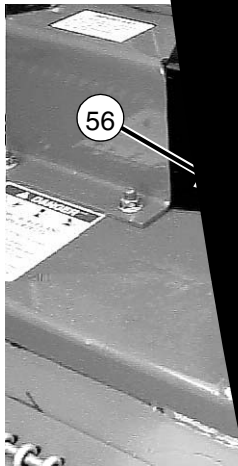

Figure 32. Front Offset Links Installed

Install Rear

1. Loosen nut on rear offset link (13) as shown in Figure 32.
2. Repeat for front offset link (14).
3. Do not tighten nut (56).



- 13. Link, rear offset
- 56. Nut, flanged lock

Figure 33. Right

Install Top Link

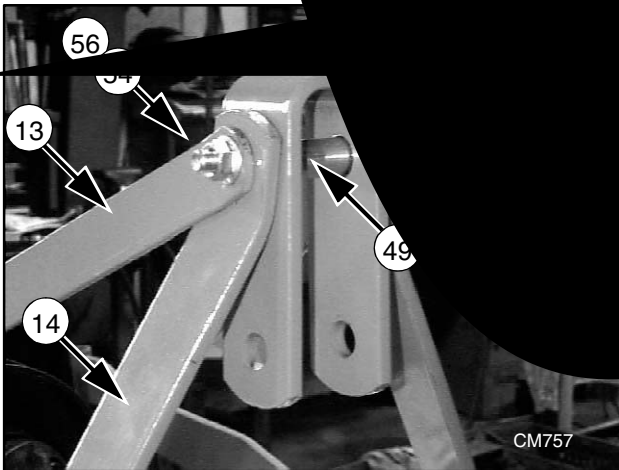

- 13. Link, rear offset
- 14. Link, front offset
- 15. Link, U-bracket
- 49. Sleeve, .62 x .84 x 2.75
- 54. Screw, HHCS 1/2 NC x 4-3/4 GR5
- 56. Nut, flanged lock 1/2 NC

Figure 34. Top Link Assembled

with rear offset links (13), and front offset links (14) and tighten with nut (56).
the lug and offset link.

assembly (3) from the front as shown in Figure 35 and tighten nuts (56).

the arm is snug against the deck.

for Wheel Interference. Adjust the front caster arm position.

to the desired position and tighten the nut.

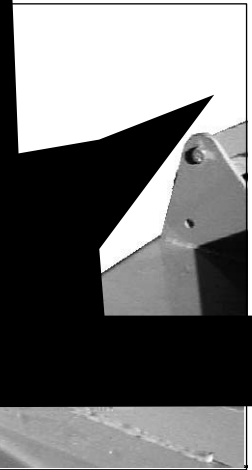

Figure 35. Rear Caster Arm Installed

Torque Caster Arm Hardware

1. Lift mower off shipping pallet and set on a hard level surface. This allows clearance in the caster wheel assemblies to be equalized.
2. Tighten all cap screws and nuts on all four caster wheel arms.
3. Tighten all cap screws and nuts to specifications found in Bolt Torque Chart on page 41.

Install Driveline Shield (RD8400-2)

The counter-cone drive shield is factory installed on models RD6000-2 and RD7200-2.

On the RD8400-2 model, attach counter-cone shield (22) to gearbox (21) with cap screws (43) and flat washers (42). Orient chain attachment lug as shown.

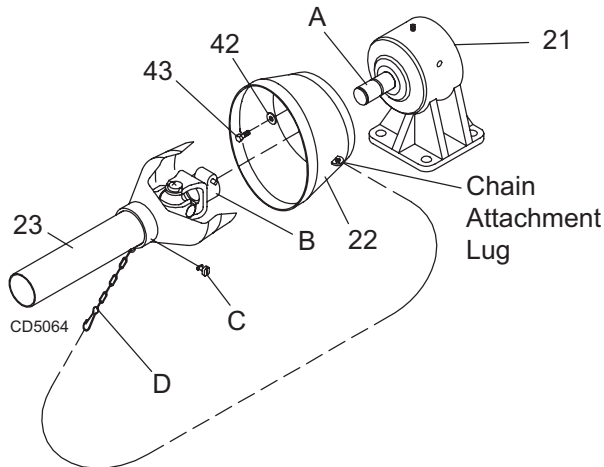

- A. Gearbox input shaft
- B. QD Yoke
- C. Shield retainer
- D. Anti-rotation chain
- 21. Gearbox
- 22. Shield, counter cone
- 23. Driveline
- 42. Washer, flat standard 5/16
- 43. Screw, HHCS 8mm x 1.25P x 16mm

Figure 36. Rear Driveshaft Installation

Install Driveshaft

1. Slide QD yoke (B) of driveshaft assembly onto gearbox shaft (A). Make sure QD yoke pin is seated securely in groove of gearbox shaft.
2. Attach shield anti-rotation chain (D) to drive shield (22) as shown.

Fill Gearbox

1. Make sure vent plug hole is clear. Fill gearbox half-full with high quality gear oil that has a viscosity index of 80W or 90W and an API service rating of GL-4 or GL-5.
2. Fill gearbox until oil runs out the side plug on gearbox.

3. Pour in one pint of gear lube, wait five minutes and add additional gear lube until it just comes out of side hole.
4. Allow an additional five minutes for the lube to flow through bearings, then check to make sure oil level is at bottom of side hole. Replace side plug. Install vent plug.

IMPORTANT

- Gearbox is not filled at the factory. Prior to delivery, make sure each gearbox is filled half-full with 80W or 90W API GL-4 or GL-5 gear lube.

Install Chain Shielding (Optional)

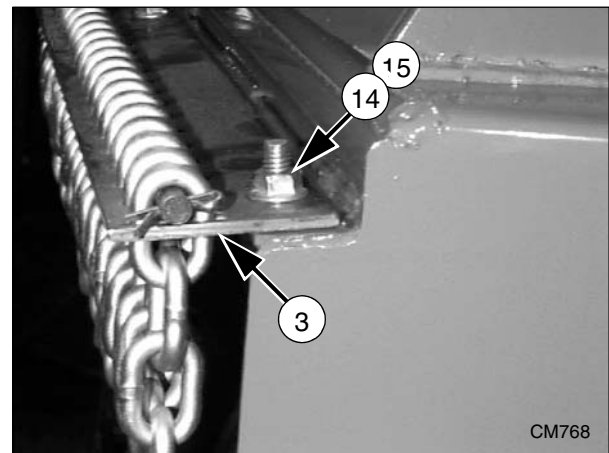

- 3. Shield, chain plate
- 14. Bolt, carriage 3/8 NC x 1
- 15. Nut, flanged lock 3/8 NC

Figure 37. Chain Shield Installed

⚠ DANGER

- Full chain shielding, designed to reduce the possibility of thrown objects, must be installed when operating in populated areas or other areas where thrown objects could injure people or damage property. If this machine is not equipped with full chain shielding, operation must be stopped when anyone comes within several hundred feet.

1. Install chain shielding plate (3) to rear mower frame as shown.
2. Secure with carriage bolts (14) and flanged lock nuts (15).
3. Inserted carriage bolts from bottom upward as shown.



DEALER CHECK LISTS

DEALER PRE-DELIVERY CHECK LIST

(DEALER'S RESPONSIBILITY)

Inspect the equipment thoroughly after assembly to ensure it is set up properly before delivering it to the customer.

The following check lists are a reminder of points to inspect. Check off each item as it is found satisfactory or after proper adjustment is made.

- ___ Check that all safety decals are installed and in good condition. Replace if damaged.
- ___ Check that shields and guards are properly installed and in good condition. Replace if damaged.

- ___ Check all bolts to be sure they are properly torqued.
- ___ Check that all cotter pins and safety pins are properly installed. Replace if damaged.
- ___ Check and grease all lubrication points as identified in "Lubrication Information" on page 14."
- ___ Gearboxes are not filled at the factory. Prior to delivery, fill as specified in the "Service, lubrication information" on page 14 and check to see that there are no leaking seals.
- ___ Check that blades have been properly installed.

DEALER DELIVERY CHECK LIST

(DEALER'S RESPONSIBILITY)

- ___ Show customer how to make adjustments and select proper PTO speed.
- ___ Instruct customer how to lubricate and explain importance of lubrication.
- ___ Point out the safety decals. Explain their meaning and the need to keep them in place and in good condition. Emphasize the increased safety hazards when instructions are not followed.
- ___ Present Operator's Manual and request that customer and all operators read it before operating equipment. Point out the manual safety rules, explain their meanings and emphasize the increased safety hazards that exist when safety rules are not followed.
- ___ Show customer how to make sure driveline is properly installed and that spring-activated locking pin or collar slides freely and is seated in groove on tractor PTO shaft.
- ___ Show customer the safe, proper procedures to be used when mounting, dismounting, and storing equipment.

- ___ Explain to customer the potential crushing hazards of going underneath raised equipment. Instruct that before going underneath to disconnect the driveline, securely block up all corners with jack stands and to follow all instructions in the "Service, blocking methods" section of the operators manual. Explain that blocking up prevents equipment dropping from hydraulic leak down, hydraulic system failures or mechanical component failures.
- ___ For mounted units, add wheel weights, ballast in front tires, and/or front tractor weight to enhance front end stability. A minimum 20% of tractor and equipment gross weight must be on front tractor wheels. When adding weight to attain 20% of tractor and equipment weight on front tractor wheels, you must not exceed the ROPS weight certification. Weigh the tractor and equipment. Do not estimate!
- ___ Make customer aware of optional equipment available so that customer can make proper choices as required.
- ___ Point out all guards and shields. Explain their importance and the safety hazards that exist when not kept in place and in good condition.

Rear Discharge Mowers:

RD6000-2

RD7200-2

RD8400-2

MAIN FRAME ASSEMBLY	34 - 35
GEARBOX ASSEMBLY	36
DRIVESHAFT ASSEMBLY (WALTERSCHEID TWO-LOBE)	37
BLADE & SPINDLE ASSEMBLY	38
REAR CHAIN SHIELDING ASSEMBLY	39
FRONT ROLLER ASSEMBLY (OPTIONAL)	39
QUICK HITCH (OPTIONAL)	40

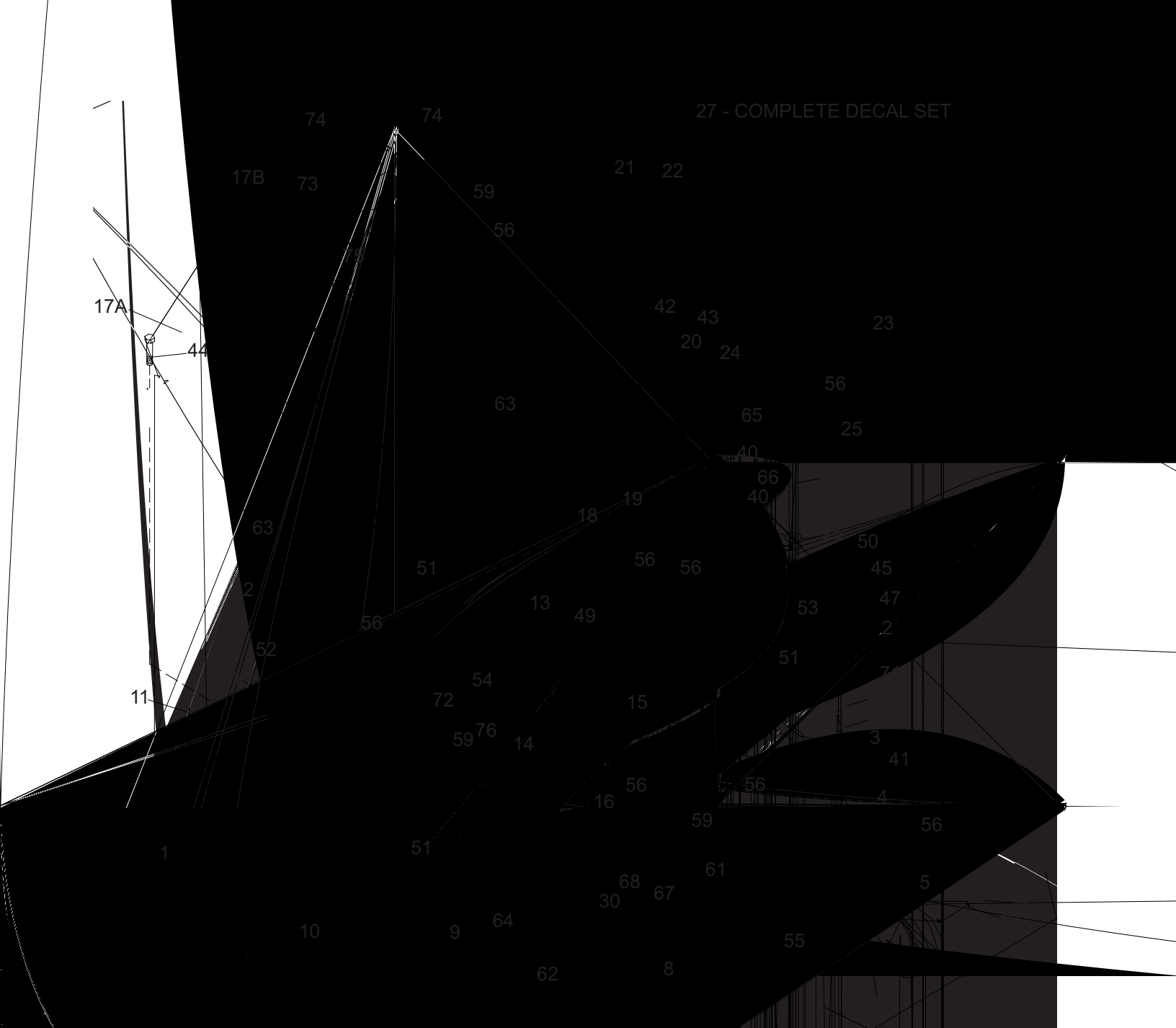

PART	QTY	DESCRIPTION
4 52859	4	Caster Yoke & Shaft Asy (pneumatic tires) RD8400-2
5 34466	5	Bearing Roller .75 x 1.38 x 1.5 -or-
5 19756	4	Bearing Roller .75 x 1.38 x 2.5 (pneumatic tires)
6 65577	8	Bearing Flanged Wheel .75 x 1.415
7 18989	4	Wheel, 10" HD w/Bearing & Sleeve, -or-
7 19754	4	Wheel, 10" w/Bearing & Sleeve, (pneumatic tires)
8 33661	2	Pin, Mounting Cat 1 w/Nut & Lock Washer

34 Parts

(Rev. 4/28/2006)
MAN0180 (Rev. 1/7/2005)

RD6000-2, RD7200-2 & RD8400-2 MAIN FRAME ASSEMBLY

REF	PART	QTY	REF	REF	PART	QTY	DESCRIPTION
9	---			45	855 *		Washer, Lock 1/2
10	1001244	1		46	24537		Washer, Flat .50 x 1.38 x .38 (used on RD6000-2 & RD7200-2) -or-
10	18879	1		46	22166		Washer, Flat .50 x 1.00 x .25 (used on RD8400-2)
10	53418	1		47	33677		Washer, Flat .50 x 1.56 x 10 GA
11	53567	1		48	31983		Washer, Shim .50 x .88 x 18 GA
12	64555	1		49	64814		Sleeve .62 x .84 x 2.75
13	55331	2		50	6100 *		Screw, HHCS 1/2 NC x 1-1/4 GR5
13	19578			51	24576 *		Screw, HHCS 1/2 NC x 1-3/4 GR5
13	52873	2		52	1517		Washer, Flat .63 x 1.38 x 7 GA
14	19579	2		53	639 *		Screw, HHCS 1/2 NC x 2-1/2 GR5
15	19605	1		54	29561 *		Screw, HHCS 1/2 NC x 4-3/4 GR5
16	52893	1		55	23479 *		Screw, HHCS 1/2 x 5 GR5
17A	55340	1		56	11900 *		Nut, Flanged Lock 1/2 NC
17A	53539	1		57	29368		Sleeve .50 x .75 x 3.38 (HD tires) -or-
17A	52874	1		57	19749		Sleeve, .50 x .75 x 4.0625 (pneumatic tires)
17B	55340	1		58	52877		Sleeve, .504 x .625 x .64 (RD8400-2)
17B	53539	1		59	19025		Nut, Flanged Lock 5/8 NC
17B	52875	1		60	22060		Seal, Felt .63 x 1.00 x .25
18	29792 *	1		61	484		Sleeve, HT .63 x 1.00 x .44
19	65197	1		62	1791		Sleeve, HT .63 x 1.00 x .56
20	53534	1		63	19024		Screw, Flngd Hex Head 5/8 NC x 1-3/4
21	1002499	1		64	34473 *		Screw, HHCS 5/8 NC x 3 GR5
22	51849	1		65	302178		Nut, Castle 5/8 NF
23	40551	1		66	35193		Bearing
24	67131	1		67	30007 *		Nut, Hex 7/8 NF
25	53595	1		68	30008 *		Washer, Lock 7/8
25	64555	1		69	33647		Sleeve 1.05 x 1.31 x .75 (used on RD6000-2 & RD7200-2) -or-
26	58989	1		69	52854		Sleeve 1.28 x 1.66 x .75 (RD8400-2)
27	55344	1		70	65129		Sleeve 1.05 x 1.31 x .50 (used on RD6000-2 & RD7200-2) -or-
27	53589	1		70	52853		Sleeve 1.28 x 1.66 x .50 (RD8400-2)
27	52889	1		71	65130		Sleeve 1.05 x 1.31 x 1.00 (used on RD6000-2 & RD7200-2) -or-
28	53590	1		71	52855		Sleeve 1.28 x 1.66 x 1.00 (RD8400-2)
29	53591	1		72	1266 *	1	Pin, Cotter 3/16 x 1-1/2
30	18824	2		73	1003828	1	Manual Tube
40	35141			74	6697 *	2	Bolt, Carriage 3/8 NC x 1 GR5
41	12296 *			75	14350	2	Nut, Flanged Lock 3/8 NC
42	4378 *			76	53543	1	Idler post
43	39254						* Obtain locally
44	62153						

RD6000-2, RD7200-2 & RD8400-2 GEARBOX ASSEMBLY

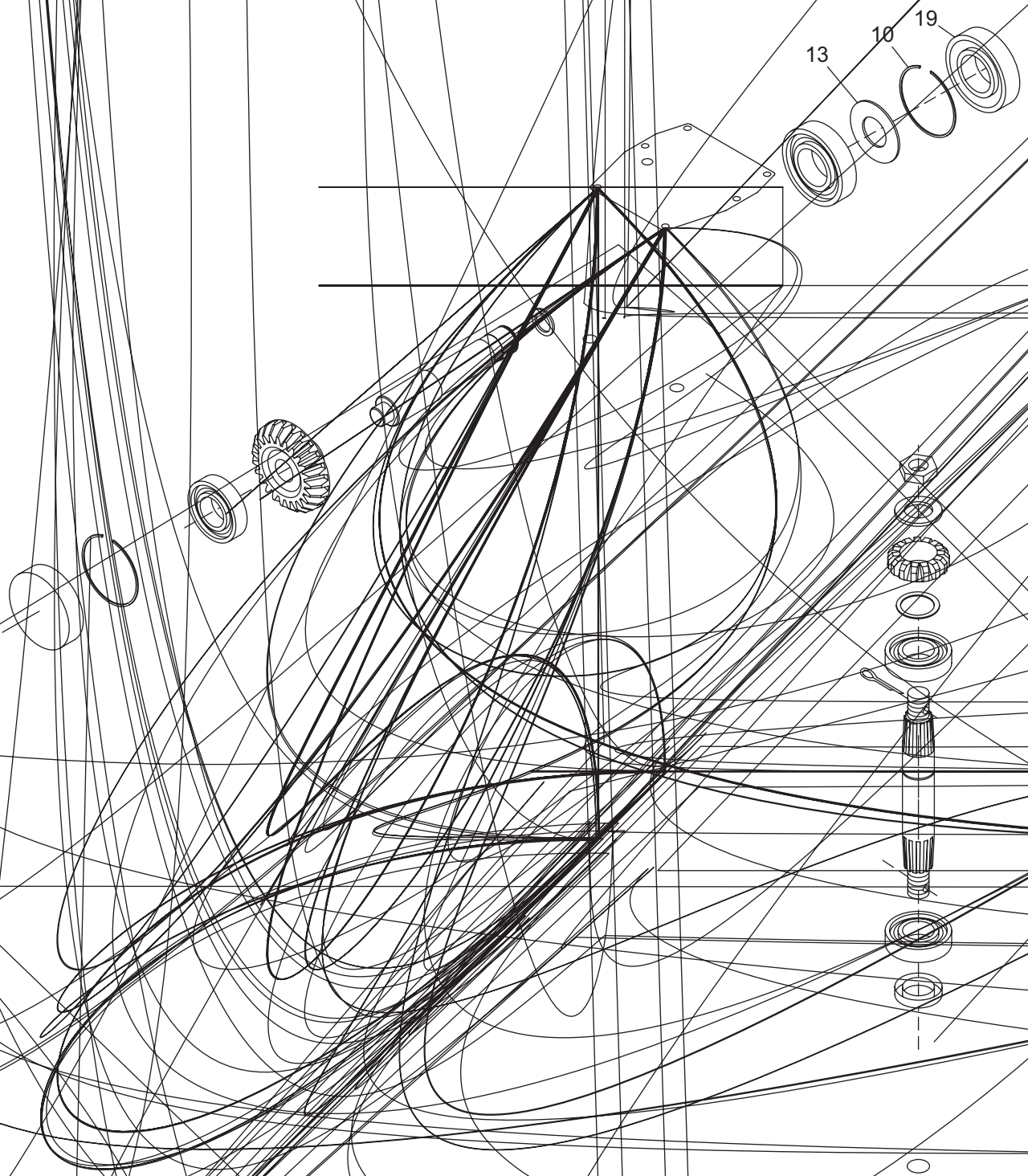

**RD6000-2, RD7200-2 & RD8400-2 DRIVESHAFT
WALTERSCHEID (TWO-LOBE SHAFT)**

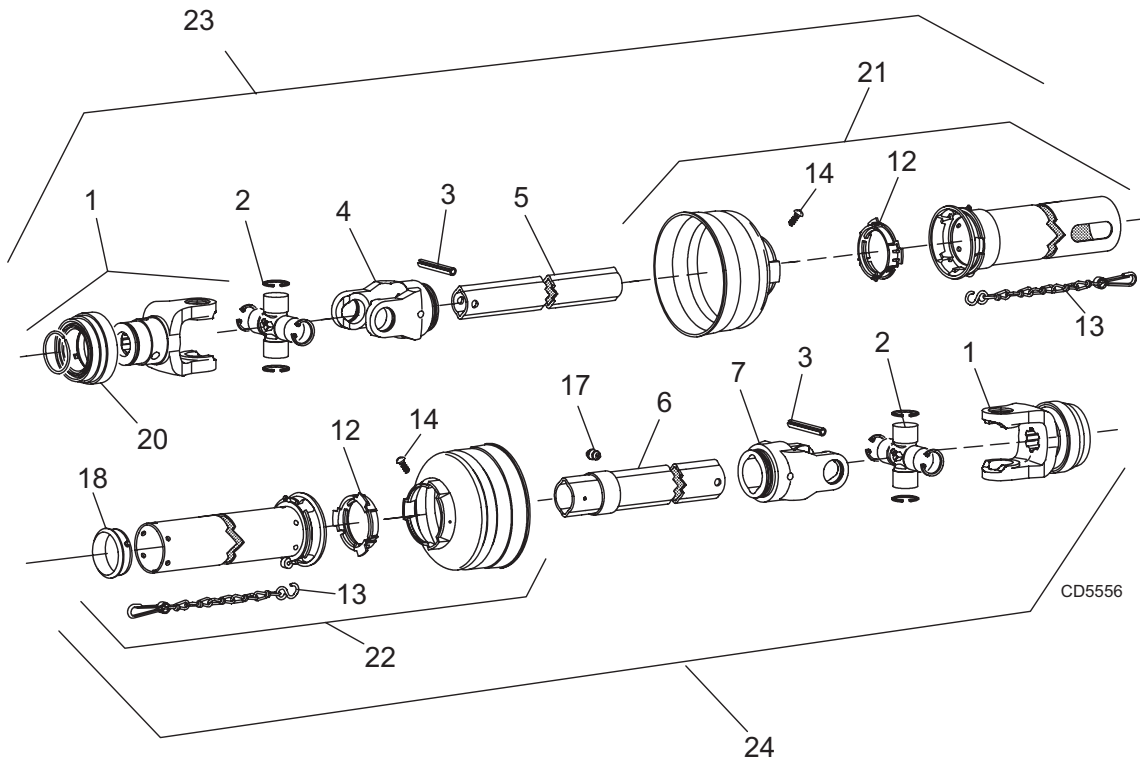

REF	PART	QTY	DESCRIPTION	REF	PART	QTY	DESCRIPTION
	40551	1	Complete Drive Shaft	14	40778	2	Screw, Guard Retainer
1	40571	2	Yoke, 1-3/8-6 Spline Q	17	40779	1	Grease Zerk, Drive Line
2	154	2	U-Joint Repair Kit L14R	18	40780	1	Bearing, Guard Support
3	40775	2	Pin, Spring 10mm x 65mm	20	40589	2	Slide Lock Collar Repair Kit (without yoke)
4	40572	1	Yoke, Inner Profile	21	40585	1	Guard, Outer Half (also includes items 12, 13 and 14)
5	40583	1	Drive Tube, Inner Profile	22	40586	1	Guard, Inner Half (also includes items 12, 13, 14 and 18)
6	40584	1	Drive Tube, Outer Profile	23	40581	1	Drive, Inner Half Complete
7	40573	1	Yoke, Outer Profile	24	40582	1	Drive, Outer Half Complete
12	40776	2	Bearing Ring, Guard				
13	40777	2	Chain, Guard Anti-Rotation				

RD6000-2, RD7200-2 & RD8400-2 BLADE & SPINDLE ASSEMBLY

REF	PART	QTY	DESCRIPTION
1	37009		Nut, Jam 7/8 NF
2	10378	*	Screw HHCS 1/4 NC x 1 GR5
3	52898		Washer, Lock .929 x 1.66
4	1985	*	Washer, Lock 1/4
5	34440		Bushing, H 1 Straight bore w/key
6	66694		Sheave, H 1 BK 4.17 PD (RD6000-2)
			-or-
6	12622		Sheave, H 1 BK 5.0 PD (RD7200-2)
			-or-
6	53419		Sheave, H 1 BK 5.9 PD (RD8400-2)
7	52881		Spindle Assembly Complete
8	52949		Seal 1.50 x 2.12 x .31
9	52872		Sleeve 1.14 x 1.50 x .55
10	29899		Bearing, Cone
11	52882		Spindle, Housing with Cups
12	29898		Bearing, Cup
14	52852		Shaft, Blade Spindle
16	1001513KT		Blade Kit, High Suction 21 In (set of 3) (RD6000-2)
16	1008199KT		Blade Kit, High Suction 25 In (set of 3) (RD7200-2)
16	53417KT		Blade Kit, High Suction 29.33 In (set of 3) (RD8400-2)
16	1001510KT		Blade Kit, Low Suction 21 In (set of 3) (RD6000-2)
16	1001511KT		Blade Kit, Low Suction 25 In (set of 3) (RD7200-2)
16	1001512KT		Blade Kit, Low Suction 29.33 In (set of 3) (RD8400-2)
19	4358		Screw, HHCS 1/2 NF x 1-1/4 GR5
21	1972		Grease Fitting, 1/4-28 tapered thread
22	3379		Screw, HHCS 1/2 NC x 1-1/2 GR5
23	11900		Nut, Flanged Lock 1/2 NC

* Standard Hardware - Obtain Locally

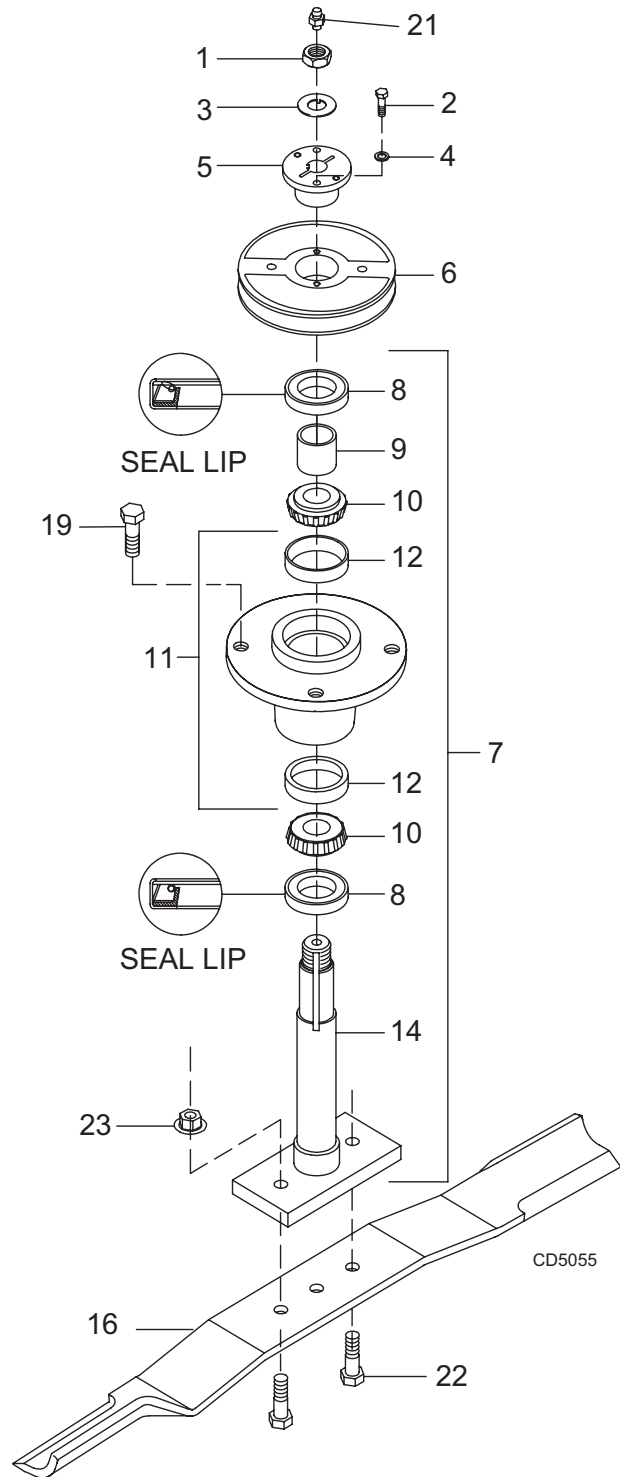

38 Parts

MAN0180 (Rev. 1/7/2005)

**RD6000-2, RD7200-2 & RD8400-2
SHIELDING ASSEMBLY (OPTIONAL)**

RD6000-2, RD7200-

FRONT

QUICK HITCH KIT (OPTIONAL)

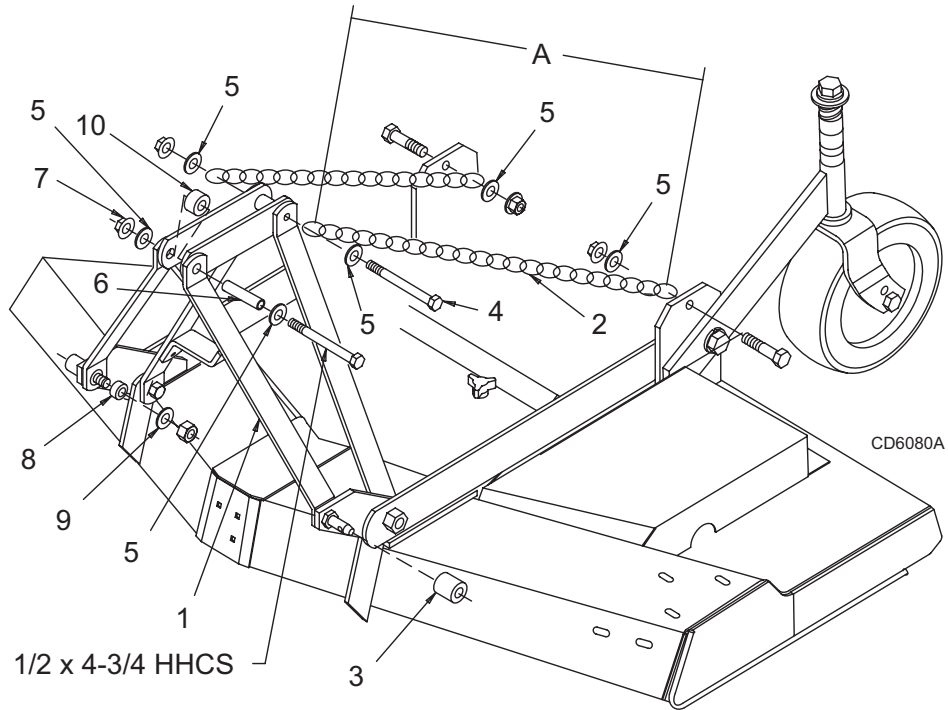

REF	PART	QTY	DESCRIPTION
1	1003692	2	Link, Offset .38 x 2.0 x 15
2	1005401	2	Chain 3/8 Proof Coil 38 Link
3	38214	2	Sleeve, .91 x 1.44 x 1.25
4	13563	1	Screw, HHCS 1/2 NC x 6 GR5
5		* 6	Washer, Flat 1/2 ZP
6	29368	1	Sleeve, .50 x .75 x 3.38
7	11900	1	Nut, Flange Lock 1/2 NC
8	29281	2	Sleeve, 7/8 x 1-1/8 x 19/32 HT
9		* 2	Washer, Flat 7/8
10	1003614	1	Sleeve, .81 x 1.25 x 1.81

* Standard Hardware, Obtain Locally

40 Parts

MAN0180 (Rev. 1/7/2005)

BOLT TORQUE CHART

Always tighten hardware to these values unless a different torque value or tightening procedure is listed for a specific application.

Fasteners must always be replaced with the same grade as specified in the manual parts list.

Always use the proper tool for tightening hardware: SAE for SAE hardware and Metric for metric hardware.

Make sure fastener threads are clean and you start thread engagement properly.

All torque values are given to specifications used on hardware defined by SAE J1701 & J1701M JUL96.

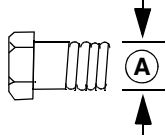

SAE SERIES TORQUE CHART

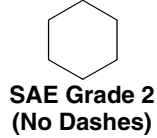

A Diameter (Inches)	Wrench Size	MARKING ON HEAD					
		SAE 2		SAE 5		SAE 8	
		lbs-ft	N-m	lbs-ft	N-m	lbs-ft	N-m
1/4"	7/16"	6	8	10	13	14	18
5/16"	1/2"	12	17	19	26	27	37
3/8"	9/16"	23	31	35	47	49	67
7/16"	5/8"	36	48	55	75	78	106
1/2"	3/4"	55	75	85	115	120	163
9/16"	13/16"	78	106	121	164	171	232
5/8"	15/16"	110	149	170	230	240	325
3/4"	1-1/8"	192	261	297	403	420	569
7/8"	1-5/16"	306	416	474	642	669	907
1"	1-1/2"	467	634	722	979	1020	1383

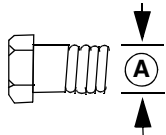

METRIC SERIES TORQUE CHART

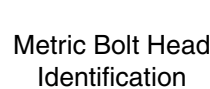
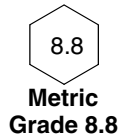

A Diameter & Thread Pitch (Millimeters)	Wrench Size	COARSE THREAD				FINE THREAD				A Diameter & Thread Pitch (Millimeters)
		MARKING ON HEAD								
		Metric 8.8		Metric 10.9		Metric 8.8		Metric 10.9		
		N-m	lbs-ft	N-m	lbs-ft	N-m	lbs-ft	N-m	lbs-ft	
6 x 1.0	10 mm	8	6	11	8	8	6	11	8	6 x 1.0
8 x 1.25	13 mm	20	15	27	20	21	16	29	22	8 x 1.0
10 x 1.5	16 mm	39	29	54	40	41	30	57	42	10 x 1.25
12 x 1.75	18 mm	68	50	94	70	75	55	103	76	12 x 1.25
14 x 2.0	21 mm	109	80	151	111	118	87	163	120	14 x 1.5
16 x 2.0	24 mm	169	125	234	173	181	133	250	184	16 x 1.5
18 x 2.5	27 mm	234	172	323	239	263	194	363	268	18 x 1.5
20 x 2.5	30 mm	330	244	457	337	367	270	507	374	20 x 1.5
22 x 2.5	34 mm	451	332	623	460	495	365	684	505	22 x 1.5
24 x 3.0	36 mm	571	421	790	583	623	459	861	635	24 x 2.0
30 x 3.0	46 mm	1175	867	1626	1199	1258	928	1740	1283	30 x 2.0

Typical Washer Installations

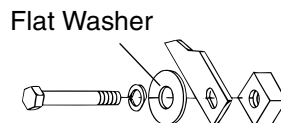
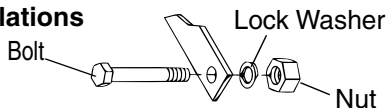

8/9/00

BOLT SIZE CHART

NOTE: Chart shows bolt thread sizes and corresponding head (wrench) sizes for standard SAE and metric bolts.

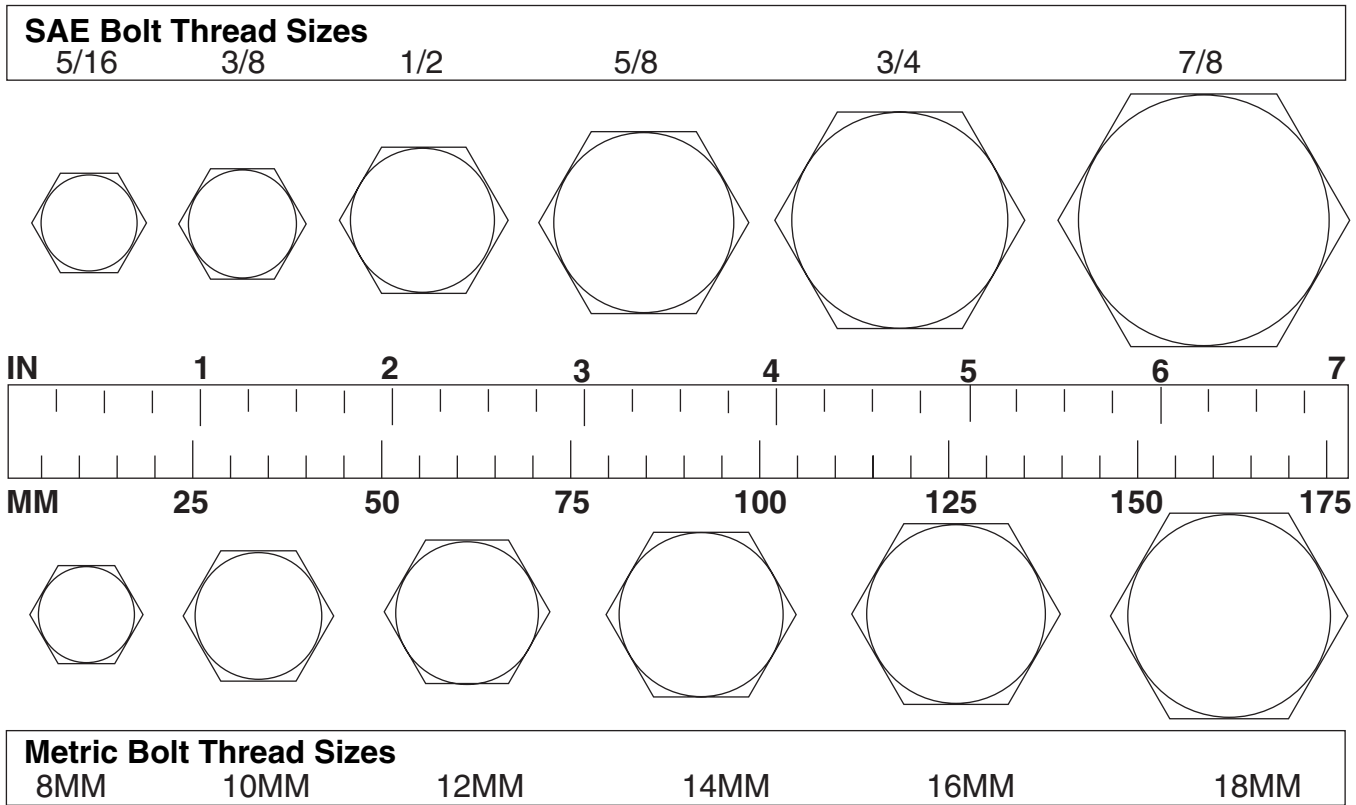

ABBREVIATIONS

AGAgriculture
 ATF Automatic Transmission Fluid
 BSPP British Standard Pipe Parallel
 BSPTM British Standard Pipe Tapered Male
 CV Constant Velocity
 CCW Counter-Clockwise
 CW Clockwise
 F Female
 GA Gauge
 GR (5, etc.) Grade (5, etc.)
 HHCS Hex Head Cap Screw
 HT Heat-Treated
 JIC Joint Industry Council 37° Degree Flare
 LH Left Hand
 LT Left
 m Meter
 mm Millimeter
 M Male
 MPa Mega Pascal
 N Newton

NC National Coarse
 NF National Fine
 NPSM National Pipe Straight Mechanical
 NPT National Pipe Tapered
 NPT SWF National Pipe Tapered Swivel Female
 ORBM O-Ring Boss - Male
 P Pitch
 PBY Power-Beyond
 psi Pounds per Square Inch
 PTO Power Take Off
 QD Quick Disconnect
 RH Right Hand
 ROPS Roll-Over Protective Structure
 RPM Revolutions Per Minute
 RT Right
 SAE Society of Automotive Engineers
 UNC Unified Coarse
 UNF Unified Fine
 UNS Unified Special

INDEX

ASSEMBLY

Dealer Set-Up Instructions 28

DEALER CHECK LISTS

Delivery (Dealer's Responsibility) 32
Pre-Delivery (Dealer's Responsibility) 32

DEALER SERVICE

Blade Spindle
 Assembly 21
 Disassembly 21
 Installation 22
 Removal 20
 Service 20
Blocking Method 20
Drive Sheave Installation 26
Gearbox
 Disassembly 24
 Horizontal Shaft Seal Reopacement 23
 Installation 26
 Reassembly 24
 Removal 24
 Repair 22
 Seal Installation 22
 Seal Replacement 22
 Vertical Shaft Seal Replacement 23
Universal Joint
 Assembly 27
 Disassembly 26
 Repair 26

GENERAL

Abbreviations 42
Bolt Size Chart 42
Bolt Torque Chart 41
General Information 2
Introduction, Inside Front Cover
Obtaining Replacement Manuals,
 Inside Front Cover
Specifications 2
Warranty
 Product 44
 Replacement Parts 45

OPERATION

Adjustment
 Cutting Height 9
 Cutting Height Chart 10
 Tractor Top Link 10

Attaching Mower to Tractor 9
Front Caster Arm Configuration 10
Front Caster Wheel Interference Check 11
Front Roller 11
Operating
 On Uneven Terrain 12
 Technique 11
 Tips 12
Pre-Operation Check List (Owners Responsibility)
 13
Removing Mower from Tractor 12
Storage 12
Tractor Stability 8

OWNER SERVICE

Belt
 Installation 16
 Replacement 16
Blade
 Install 16
 Service 16
 Sharpening 17
Blocking Method 14
Chain Shielding 17
Cleaning 17
Lubrication
 Driveshaft 15
 Information 14
 Points 15

PARTS

Parts Index 33

SAFETY

Blocking Method 14, 20
Dealer Check Lists
 Delivery (Dealer's Responsibility) 32
 Pre-Delivery (Dealer's Responsibility) 32
Owner Pre-Operation (Owners Responsibility) 13
Safety & Instructional Decals 6, 7
Safety Rules 3, 4, 5
Safety Symbols explained, Inside Front Cover

TROUBLE SHOOTING

Belt Conditions 19
Mowing Conditions , Inside Front Cover



WARRANTY

(All Models Except Mow'n Machine™ Zero-Turn Mowers and Woods Boundary™ Utility Vehicles)

Please Enter Information Below and Save for Future Reference.

Date Purchased: _____

From (Dealer): _____

Model Number: _____

Serial Number: _____

**Woods Equipment
Company**

2606 South Illinois Route 2
Post Office Box 1000
Oregon, Illinois 61061

800-319-6637 tel
800-399-6637 fax
www.WoodsEquipment.com

WOODS®

ALITEC™

BMP®

CENTRAL FABRICATORS®

GANNON®

GILL®

WAIN-ROY®

WOODS®



WARRANTY

(Replacement Parts For All Models Except Mow'n Machine™
Zero-Turn Mowers and Woods Boundary™ Utility Vehicles)

Woods Equipment Company ("WOODS") warrants this product to be free from defect in material and workmanship for a period of ninety (90) days from the date of delivery of the product to the original purchaser with the exception of V-belts, which will be free of defect in material and workmanship for a period of 12 months.

Under no circumstances will this Warranty apply in the event that the product, in the good faith opinion of WOODS, has been subjected to improper operation, improper maintenance, misuse, or an accident. This Warranty does not cover normal wear or tear, or normal maintenance items.

This Warranty is extended solely to the original purchaser of the product. Should the original purchaser sell or otherwise transfer this product to a third party, this Warranty does not transfer to the third party purchaser in any way. There are no third party beneficiaries of this Warranty.

WOODS' obligation under this Warranty is limited to, at WOODS' option, the repair or replacement, free of charge, of the product if WOODS, in its sole discretion, deems it to be defective or in noncompliance with this Warranty. **The product must be returned to WOODS with proof of purchase within thirty (30) days after such defect or noncompliance is discovered or should have been discovered, routed through the dealer and distributor from whom the purchase was made, transportation charges prepaid.** WOODS shall complete such repair or replacement within a reasonable time after WOODS receives the product. THERE ARE NO OTHER REMEDIES UNDER THIS WARRANTY. THE REMEDY OF REPAIR OR REPLACEMENT IS THE SOLE AND EXCLUSIVE REMEDY UNDER THIS WARRANTY.

THERE ARE NO WARRANTIES WHICH EXTEND BEYOND THE DESCRIPTION ON THE FACE OF THIS WARRANTY. WOODS MAKES NO OTHER WARRANTY, EXPRESS OR IMPLIED, AND WOODS SPECIFICALLY DISCLAIMS ANY IMPLIED WARRANTY OF MERCHANTABILITY AND/OR ANY IMPLIED WARRANTY OF FITNESS FOR A PARTICULAR PURPOSE.

WOODS shall not be liable for any incidental or consequential losses, damages or expenses, arising directly or indirectly from the product, whether such claim is based upon breach of contract, breach of warranty, negligence, strict liability in tort or any other legal theory. Without limiting the generality of the foregoing, Woods specifically disclaims any damages relating to (i) lost profits, business, revenues or goodwill; (ii) loss of crops; (iii) loss because of delay in harvesting; (iv) any expense or loss incurred for labor, supplies, substitute machinery or rental; or (v) any other type of damage to property or economic loss.

This Warranty is subject to any existing conditions of supply which may directly affect WOODS' ability to obtain materials or manufacture replacement parts.

No agent, representative, dealer, distributor, service person, salesperson, or employee of any company, including without limitation, WOODS, its authorized dealers, distributors, and service centers, is authorized to alter, modify, or enlarge this Warranty.

Answers to any questions regarding warranty service and locations may be obtained by contacting:

WOODS®

ALITEC™
BMP®
CENTRAL FABRICATORS®
GANNON®
GILL®
WAIN-ROY®
WOODS®

PART NO.
MAN0180

815-732-2141 tel
815-732-7580 fax
www.WoodsEquipment.com

WOODS[®]

© 2002 Woods Equipment Company. All rights reserved. WOODS, the Woods logo, and "Tested. Proven. Unbeatable." are trademarks of Woods Equipment Company. All other trademarks, trade names, or service marks not owned by Woods Equipment Company that appear in this manual are the property of their respective companies or mark holders. Specifications subject to change without notice.

Free Manuals Download Website

<http://myh66.com>

<http://usermanuals.us>

<http://www.somanuals.com>

<http://www.4manuals.cc>

<http://www.manual-lib.com>

<http://www.404manual.com>

<http://www.luxmanual.com>

<http://aubethermostatmanual.com>

Golf course search by state

<http://golfingnear.com>

Email search by domain

<http://emailbydomain.com>

Auto manuals search

<http://auto.somanuals.com>

TV manuals search

<http://tv.somanuals.com>