

WOODS ROTARY TILLERS

TC60
TC68
TC74
TCR60
TCR68
TCR74

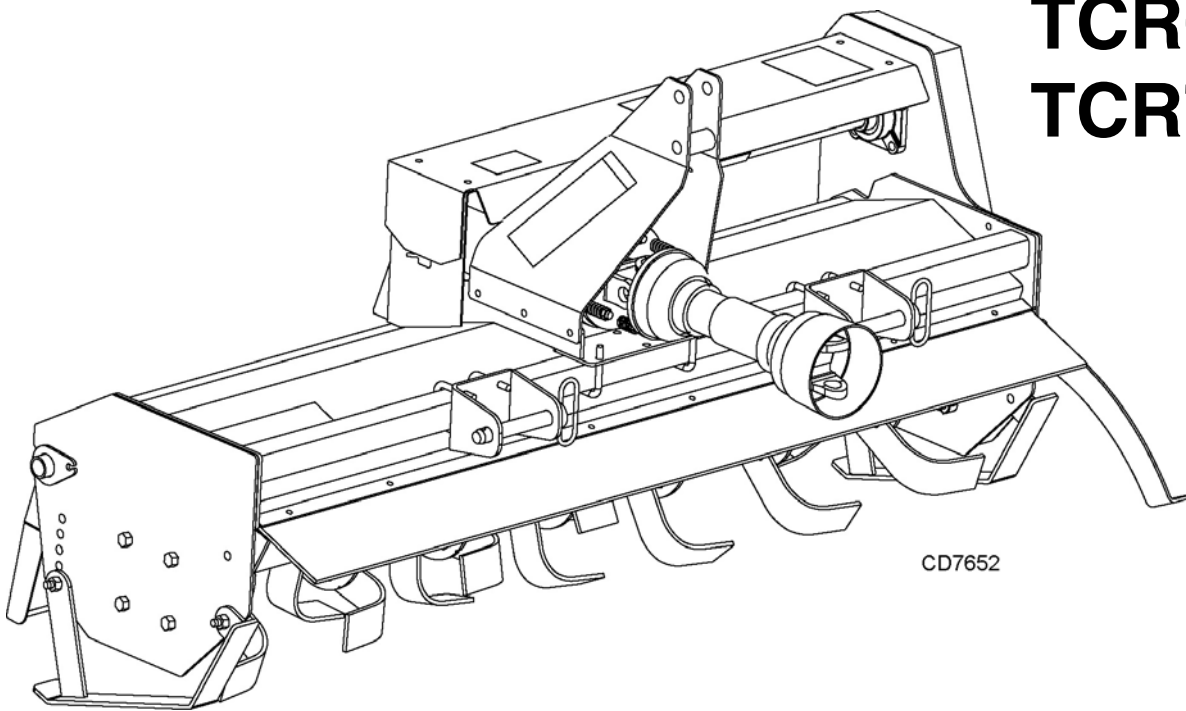

CD7652

MAN0813
(Rev. 3/1/2012)

WOODS®

OPERATOR'S MANUAL

TO THE DEALER:

Assembly and proper installation of this product is the responsibility of the Woods® dealer. Read manual instructions and safety rules. Make sure all items on the Dealer's Pre-Delivery and Delivery Check Lists in the Operator's Manual are completed before releasing equipment to the owner.

The dealer must complete the online Product Registration form at the Woods Dealer Website which certifies that all Dealer Check List items have been completed. Dealers can register all Woods product at dealer.WoodsEquipment.com under Product Registration.

Failure to register the product does not diminish customer's warranty rights.

TO THE OWNER:

Read this manual before operating your Woods equipment. The information presented will prepare you to do a better and safer job. Keep this manual handy for ready reference. Require all operators to read this manual carefully and become acquainted with all adjustment and operating procedures before attempting to operate. Replacement manuals can be obtained from your dealer. To locate your nearest dealer, check the Dealer Locator at www.WoodsEquipment.com, or in the United States and Canada call 1-800-319-6637.

The equipment you have purchased has been carefully engineered and manufactured to provide dependable and satisfactory use. Like all mechanical products, it will require cleaning and upkeep. Lubricate the unit as specified. Observe all safety information in this manual and safety decals on the equipment.

For service, your authorized Woods dealer has trained mechanics, genuine Woods service parts, and the necessary tools and equipment to handle all your needs.

Use only genuine Woods service parts. Substitute parts will void the warranty and may not meet standards required for safe and satisfactory operation. Record the model number and serial number of your equipment in the spaces provided:

Model: _____ **Date of Purchase:** _____

Serial Number: (see Safety Decal section for location) _____

Provide this information to your dealer to obtain correct repair parts.

Throughout this manual, the term **NOTICE** is used to indicate that failure to observe can cause damage to equipment. The terms **CAUTION**, **WARNING**, and **DANGER** are used in conjunction with the Safety-Alert Symbol (a triangle with an exclamation mark) to indicate the degree of hazard for items of personal safety.



This is the safety alert symbol. It is used to alert you to potential physical injury hazards. Obey all safety messages that follow this symbol to avoid possible injury or death.



Indicates a hazardous situation that, if not avoided, will result in death or serious injury.



Indicates a hazardous situation that, if not avoided, could result in death or serious injury.



Indicates a hazardous situation that, if not avoided, could result in minor or moderate injury.

**IMPORTANT
or NOTICE**

Is used to address practices not related to physical injury.

NOTE

Indicates helpful information.

ALITEC™

BMP®

CENTRAL FABRICATORS®

GANNON®

GILL®

WAIN-ROY®

WOODS®

WOODS®

2 Introduction

Gen'l (Rev. 12/5/2011)

TABLE OF CONTENTS

INTRODUCTION	2
SPECIFICATIONS	4
GENERAL INFORMATION	4
SAFETY RULES	5
SAFETY DECALS	8
OPERATION	10
OWNER SERVICE	15
TROUBLESHOOTING	19
DEALER SERVICE	20
ASSEMBLY	24
DEALER CHECK LISTS	26
INDEX TO PARTS LISTS	27
BOLT TORQUE CHART	37
BOLT SIZE CHART & ABBREVIATIONS	38
PRODUCT WARRANTY	INSIDE BACK COVER
REPLACEMENT PARTS WARRANTY	BACK COVER

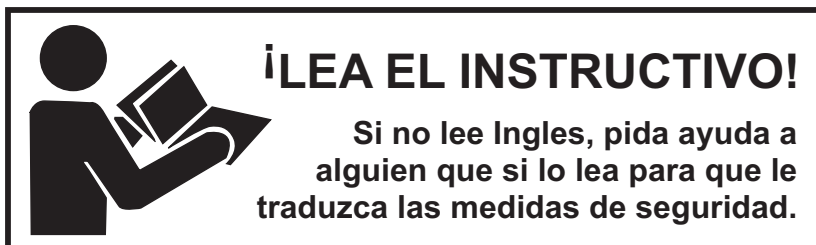

This Operator's Manual should be regarded as part of the machine. Suppliers of both new and second-hand machines must make sure that this manual is provided with the machine.

SPECIFICATIONS

	<u>TC60 and TCR60</u>	<u>TC68 and TCR68</u>	<u>TC74 and TCR74</u>
Tilling Width	60"	68"	74"
Maximum Tilling Depth	7-1/2"	7-1/2"	7-1/2"
Operating Weight	597 lbs/604 lbs (R)	634 lbs/641 lbs (R)	665 lbs/672 lbs (R)
Rotor Swing Diameter	17-1/2"	17-1/2"	17-1/2"
Number of Blade Flanges	7	8	9
Number of Blades	42	48	54
Drive Type	#80 Chain	#80 Chain	#80 Chain
Tractor PTO Speed	540 RPM	540 RPM	540 RPM
Rotor Speed	240 RPM	240 RPM	240 RPM
Tractor Hitch	Limited Category 1 & Category1	Limited Category 1 & Category1	Limited Category 1 & Category1
Tractor Horsepower	Up to 45 HP	UP to 45 HP	Up to 45 HP
Skid Shoe Adjustments	5 x 1"	5 x 1"	5 x 1"
Side-Shift Distance	15-1/2"	19-1/2"	22-1/2"
Gearbox Oil Capacity	1.2 QT SAE 80W-90	1.2 QT SAE 80W-90	1.2 QT SAE 80W-90
Chain Case Oil Capacity	.78 QT SAE #00 *	.78 QT SAE #00 *	.78 QT SAE #00 *
* Chain case #00 grease is factory installed			

GENERAL INFORMATION

WARNING

■ Some illustrations in this manual show the equipment with safety shields removed to provide a better view. This equipment should never be operated with any necessary safety shielding removed.

The purpose of this manual is to assist you in operating and maintaining your rotary tiller. Read it carefully. It furnishes information and instructions that will help you achieve years of dependable performance. These instructions have been compiled from extensive field experience and engineering data. Some information

may be general in nature due to unknown and varying operating conditions. However, through experience and these instructions, you should be able to develop procedures suitable to your particular situation.

The illustrations and data used in this manual were current at the time of printing but, due to possible inline production changes, your machine may vary slightly in detail. We reserve the right to redesign and change the machines as may be necessary without notification.

Throughout this manual, references are made to right and left directions. These are determined by standing behind the equipment, facing the direction of the forward travel.

SAFETY RULES



ATTENTION! BECOME ALERT! YOUR SAFETY IS INVOLVED!



Safety is a primary concern in the design and manufacture of our products. Unfortunately, our efforts to provide safe equipment can be wiped out by an operator's single careless act.

In addition to the design and configuration of equipment, hazard control and accident prevention are dependent upon the awareness, concern, judgement, and proper training of personnel involved in the operation, transport, maintenance and storage of equipment.

It has been said "The best safety device is an informed, careful operator." We ask you to be that kind of operator.

TRAINING

- **Safety instructions are important! Read all attachment and power unit manuals; follow all safety rules and safety decal information. (Replacement manuals and safety decals are available from your dealer. To locate your nearest dealer, check the Dealer Locator at www.WoodsEquipment.com, or in the United States and Canada call 1-800-319-6637.) Failure to follow instructions or safety rules can result in serious injury or death.**
- **If you do not understand any part of this manual and need assistance, see your dealer.**
- **Know your controls and how to stop engine and attachment quickly in an emergency.**
- **Operators must be instructed in and be capable of the safe operation of the equipment, its attachments, and all controls. Do not allow anyone to operate this equipment without proper instructions.**
- **Never allow children or untrained persons to operate equipment.**

PREPARATION

- **Check that all hardware is properly installed. Always tighten to torque chart specifications unless instructed otherwise in this manual.**
- **Always wear relatively tight and belted clothing to avoid getting caught in moving parts. Wear sturdy, rough-soled work shoes and protective equipment for eyes, hair, hands, hearing, and head; and respirator or filter mask where appropriate.**
- **Make sure attachment is properly secured, adjusted, and in good operating condition.**

- **Make sure spring-activated locking pin or collar slides freely and is seated firmly in tractor PTO spline groove.**
- **Before putting equipment into service, check and adjust driveline length as instructed in Operator's Manual. Driveline must not bottom out or pull apart throughout the full range of the tractor hitch. Do not operate until driveline length is correct.**
- **Before starting power unit, check all equipment driveline guards for damage. Replace any damaged guards. Make sure all guards rotate freely on all drivelines. If guards do not rotate freely on drivelines, repair and replace bearings before putting equipment into service.**
- **Power unit must be equipped with ROPS or ROPS cab and seat belt. Keep seat belt securely fastened. Falling off power unit can result in death from being run over or crushed. Keep foldable ROPS systems in "locked up" position at all times.**
- **Remove accumulated debris from this equipment, power unit, and engine to avoid fire hazard.**
- **Make sure all safety decals are installed. Replace if damaged. (See Safety Decals section for location.)**
- **Make sure shields and guards are properly installed and in good condition. Replace if damaged.**
- **A minimum 20% of tractor and equipment weight must be on the tractor front wheels when attachments are in transport position. Without this weight, front tractor wheels could raise up resulting in loss of steering. The weight may be attained with front wheel weights, ballast in tires or front tractor weights. Weigh the tractor and equipment. Do not estimate.**
- **Inspect and clear area of stones, branches, or other hard objects that might be thrown, causing injury or damage.**

OPERATION

- **Only engage power when equipment is at ground operating level. Always disengage power when equipment is raised off the ground.**
- **Do not allow bystanders in the area when operating, attaching, removing, assembling, or servicing equipment.**

(Safety Rules continued on next page)



SAFETY RULES

ATTENTION! BECOME ALERT! YOUR SAFETY IS INVOLVED!



(Safety Rules continued from previous page)

- Keep bystanders away from equipment.
- Never direct discharge toward people, animals, or property.
- Do not operate equipment while under the influence of alcohol or drugs.
- Operate only in daylight or good artificial light.
- Keep hands, feet, hair, and clothing away from equipment while engine is running. Stay clear of all moving parts.
- Always comply with all state and local lighting and marking requirements.
- Never allow riders on power unit or attachment.
- Power unit must be equipped with ROPS or ROPS cab and seat belt. Keep seat belt securely fastened. Falling off power unit can result in death from being run over or crushed. Keep foldable ROPS systems in “locked up” position at all times.
- Always sit in power unit seat when operating controls or starting engine. Securely fasten seat belt, place transmission in neutral, engage brake, and ensure all other controls are disengaged before starting power unit engine.
- Operate tractor PTO at 540 RPM. Do not exceed.
- Do not operate PTO during transport.
- Connect PTO driveline directly to power unit PTO shaft. Never use adapter sleeves or adapter shafts. Adapters can cause driveline failures due to incorrect spline or incorrect operating length and can result in personal injury or death.
- Look down and to the rear and make sure area is clear before operating in reverse.
- Use extreme care when working close to fences, ditches, other obstructions, or on hillsides.
- Do not operate or transport on steep slopes.
- Do not stop, start, or change directions suddenly on slopes.
- Use extreme care and reduce ground speed on slopes and rough terrain.
- Watch for hidden hazards on the terrain during operation.
- Stop power unit and equipment immediately upon striking an obstruction. Turn off engine, remove key, inspect, and repair any damage before resuming operation.

- Before performing any service or maintenance, disconnect driveline from tractor PTO.
- Before dismounting power unit or performing any service or maintenance, follow these steps: disengage power to equipment, lower the 3-point hitch and all raised components to the ground, operate valve levers to release any hydraulic pressure, set parking brake, stop engine, remove key, and unfasten seat belt.
- Never go underneath equipment (lowered to the ground or raised) unless it is properly blocked and secured. Never place any part of the body underneath equipment or between moveable parts even when the engine has been turned off. Hydraulic system leak down, hydraulic system failures, mechanical failures, or movement of control levers can cause equipment to drop or rotate unexpectedly and cause severe injury or death. Follow Operator's Manual instructions for working underneath and blocking requirements or have work done by a qualified dealer.

MAINTENANCE

- Service and maintenance work not covered in OWNER SERVICE must be done by a qualified dealership. Special skills, tools, and safety procedures may be required. Failure to follow these instructions can result in serious injury or death.
- Before performing any service or maintenance, disconnect driveline from tractor PTO.
- Before dismounting power unit or performing any service or maintenance, follow these steps: disengage power to equipment, lower the 3-point hitch and all raised components to the ground, operate valve levers to release any hydraulic pressure, set parking brake, stop engine, remove key, and unfasten seat belt.
- Never go underneath equipment (lowered to the ground or raised) unless it is properly blocked and secured. Never place any part of the body underneath equipment or between moveable parts even when the engine has been turned off. Hydraulic system leak down, hydraulic system failures, mechanical failures, or movement of control levers can cause equipment to drop or rotate unexpectedly and cause severe injury or death. Follow Operator's Manual instructions for working underneath and blocking requirements or have work done by a qualified dealer.

SAFETY RULES



ATTENTION! BECOME ALERT! YOUR SAFETY IS INVOLVED!



- Do not modify or alter or permit anyone else to modify or alter the equipment or any of its components in any way.
- Your dealer can supply original equipment hydraulic accessories and repair parts. Substitute parts may not meet original equipment specifications and may be dangerous.
- Always wear relatively tight and belted clothing to avoid entanglement in moving parts. Wear sturdy, rough-soled work shoes and protective equipment for eyes, hair, hands, hearing, and head.
- Do not allow bystanders in the area when operating, attaching, removing, assembling, or servicing equipment.
- Make sure attachment is properly secured, adjusted, and in good operating condition.
- Never perform service or maintenance with engine running.
- Keep all persons away from operator control area while performing adjustments, service, or maintenance.

- Tighten all bolts, nuts, and screws to torque chart specifications. Check that all cotter pins are installed securely to ensure equipment is in a safe condition before putting unit into service.

- Make sure all safety decals are installed. Replace if damaged. (See Safety Decals section for location.)

- Make sure shields and guards are properly installed and in good condition. Replace if damaged.

- Use a suitable lifting device of sufficient capacity. Use adequate personnel to handle heavy components.

STORAGE

- Follow manual instructions for storage.

- Keep children and bystanders away from storage area.



SAFETY & INSTRUCTIONAL DECALS



ATTENTION! BECOME ALERT! YOUR SAFETY IS INVOLVED!



Replace Immediately If Damaged!

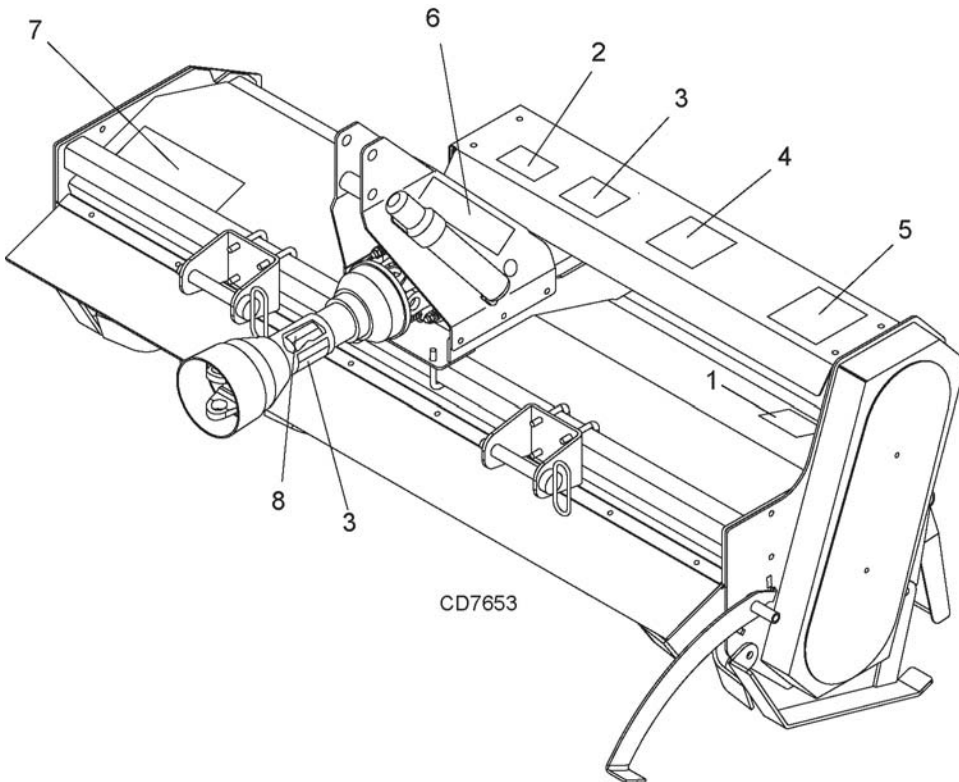

6 - PN 1002941



CRUSHING AND PINCHING HAZARD

- Be extremely careful handling various parts of the machine. They are heavy and hands, fingers, feet, and other body parts could be crushed or pinched between tractor and implement.
- Operate tractor controls from tractor seat only.
- Do not stand between tractor and implement when tractor is in gear.
- Make sure parking brake is engaged before going between tractor and implement.
- Stand clear of machine while in operation or when it is being raised or lowered.

FAILURE TO FOLLOW THESE INSTRUCTIONS COULD RESULT IN SERIOUS INJURY OR DEATH.

1002941-A

1 - PN 18868



2 - PN 18866



3 - PN 18864



8 - PN 33347



SAFETY & INSTRUCTIONAL DECALS



ATTENTION! BECOME ALERT! YOUR SAFETY IS INVOLVED!



Replace Immediately If Damaged!

7 - 1004299

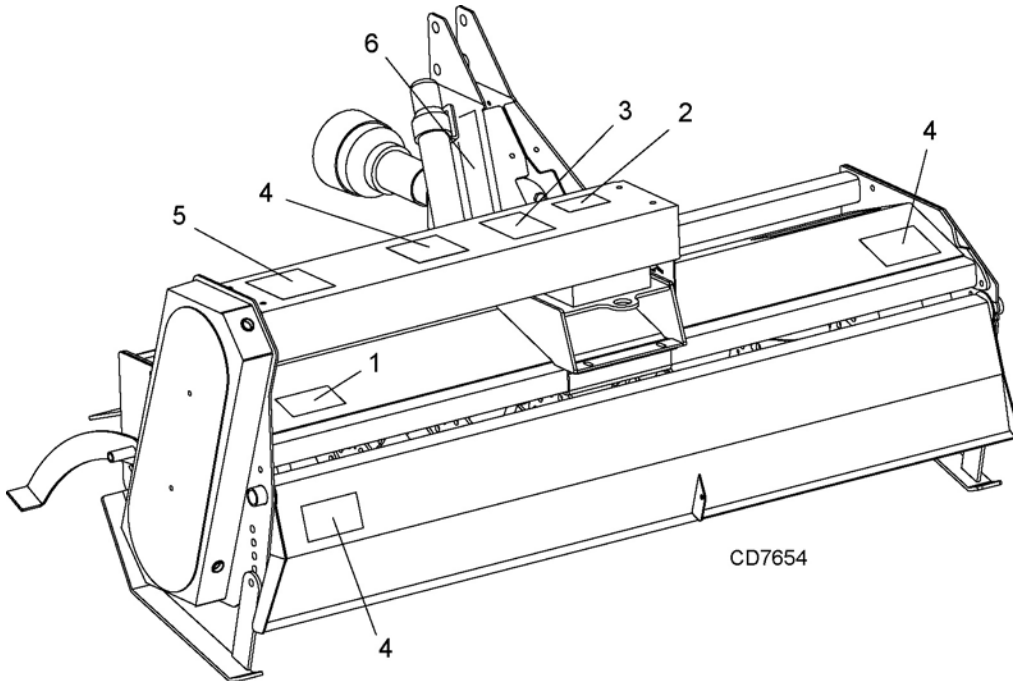

4 - P0021

! DANGER





KEEP AWAY FROM FRONT AND REAR OPENINGS WHEN TRACTOR IS RUNNING.

- Objects can be thrown by rotating blades.
- Contact with rotating blades will cause injury.

FAILURE TO FOLLOW THESE INSTRUCTIONS COULD RESULT IN SERIOUS INJURY OR DEATH.

P0021

BE CAREFUL!

Use a clean, damp cloth to clean safety decals.

Avoid spraying too close to decals when using a pressure washer; high-pressure water can enter through very small scratches or under edges of decals causing them to peel or come off.

Replacement safety decals can be ordered free from your Woods dealer. To locate your nearest dealer, check the Dealer Locator at www.woodsonline.com, or in the United States and Canada call 1-800-319-6637.

! WARNING



FALLING OFF CAN RESULT IN BEING RUN OVER.

- Tractor must be equipped with ROPS (or ROPS CAB) and seat belt. Keep foldable ROPS systems in "locked up" position at all times.
- Buckle Up! Keep seat belt securely fastened.
- Allow no riders.

RAISED IMPLEMENT CAN DROP AND CRUSH.

- Never go underneath raised implement which can drop from equipment or tractor 3-point hitch hydraulic leak down, hydraulic system failures, movement of control levers, or mechanical linkage failures.
- Service work does not require going underneath implement. Read manual instructions.

FALLING OFF OR GOING UNDERNEATH IMPLEMENT CAN RESULT IN SERIOUS INJURY OR DEATH.

1004299

5 - PN 55122

! WARNING

TO AVOID SERIOUS INJURY OR DEATH:

- Read Operator's Manual before operating, servicing or repairing equipment. Follow all safety rules and instructions. (Manuals are available from dealer or call 1-800-319-6637.)
- Operate from tractor seat only.
- Lower equipment to ground, stop engine, remove key and set brake before dismounting tractor.
- Never allow children or untrained persons to operate equipment.
- Never allow riders.
- Keep bystanders away from equipment during operation.
- Keep all shields in place and in good condition.

FAILURE TO FOLLOW THESE INSTRUCTIONS CAN RESULT IN INJURY OR DEATH.

55122-C

OPERATION

The TC rotary tiller is designed for completion of plowing operations and seedbed preparation. It breaks up clods, levels the soil surface, destroys weeds, and mixes in fertilizer. Refer to the information in this manual for the specifications, parts, assemblies, and adjustments.

The operator is responsible for the safe operation of this rotary tiller. The operator must be properly trained. Operators should be familiar with the tractor, tiller, and all safety practices before starting operation. Read the safety rules and safety decals on page 5 through page 9.

WARNING

■ **Safety instructions are important! Read all attachment and power unit manuals; follow all safety rules and safety decal information. (Replacement manuals and safety decals are available from your dealer. To locate your nearest dealer, check the Dealer Locator at www.WoodsEquipment.com, or in the United States and Canada call 1-800-319-6637.) Failure to follow instructions or safety rules can result in serious injury or death.**

■ **Power unit must be equipped with ROPS or ROPS cab and seat belt. Keep seat belt securely fastened. Falling off power unit can result in death from being run over or crushed. Keep foldable ROPS system in “locked up” position at all times.**

■ **Do not allow bystanders in the area when operating, attaching, removing, assembling, or servicing equipment.**

■ **Never allow children or untrained persons to operate equipment.**

■ **Never go underneath equipment (lowered to the ground or raised) unless it is properly blocked and secured. Never place any part of the body underneath equipment or between moveable parts even when the engine has been turned off. Hydraulic system leak down, hydraulic system failures, mechanical failures, or movement of control levers can cause equipment to drop or rotate unexpectedly and cause severe injury or death. Follow Operator's Manual instructions for working underneath and blocking requirements or have work done by a qualified dealer.**

WARNING

■ **Before dismounting power unit or performing any service or maintenance, follow these steps: disengage power to equipment, lower the 3-point hitch and all raised components to the ground, operate valve levers to release any hydraulic pressure, set parking brake, stop engine, remove key, and unfasten seat belt.**

■ **Make sure spring-activated locking pin or collar slides freely and is seated firmly in tractor PTO spline groove.**

■ **Operate tractor PTO at 540 RPM. Do not exceed.**

■ **Make sure attachment is properly secured, adjusted, and in good operating condition.**

ATTACHING ROTARY TILLER TO TRACTOR

1. Move the tractor into position in front of the tiller. Move back slowly and carefully, not allowing anyone to be between the tractor and the tiller.
2. Turn off tractor engine.
3. Attach the two lower arms of the 3-point hitch with the two hitch-pin assemblies.
4. Attach the tractor center link to the upper hitch point of the rotary tiller. Adjust the length of the center link until the tops of the frame ends are parallel to the ground.
5. Adjust the tractor lower 3-point arm anti-sway devices to prevent tiller from swinging side to side during transport.
6. Attach the front PTO driveline from the rotary tiller to the tractor. (Slide the front section of the PTO driveline into the back section. Slide the PTO shaft onto the rear PTO output of the tractor).

NOTICE

■ **If the PTO driveline is too long, severe driveline and gearbox damage is possible when hooking up the PTO driveline from the rotary tiller to the tractor. The front PTO driveline is long enough to fit a variety of tractors. It is possible that the front PTO driveline will need to be cut. There will be NO benefit by cutting only one telescoping section. Both sections of the driveline must be cut. DO NOT FORCE THE PTO TO FIT.**

■ **WARRANTY IS VOID IF THE PTO DRIVELINE IS TOO LONG, resulting in gearbox, PTO, yoke or cross bearing damage.**

NOTE: The PTO driveline, when attached to the tractor and gearbox, must not extend so there is less than four inches of overlap within the PTO driveline.

7. Raise jackstand and secure in operating position.

DRIVELINE ATTACHMENT

Attach the rotary tiller to the tractor 3-point hitch (or quick hitch if available). Do not attach driveline. Raise and lower the tiller to determine maximum and minimum distance between the tractor PTO shaft and the gearbox input shaft. If the distance is too large, the driveline will be too short for proper engagement. If the distance is too small, the driveline may bottom out in operation and damage the tiller or tractor.

If the driveline is too short, please call your Woods dealer for a longer driveline.

If the driveline is too long, please follow the instructions for shortening the driveline.

SHORTENING DRIVELINE

1. Move the tiller up and down to get the shortest possible distance between tractor PTO shaft and gearbox input shaft. Leave the tiller in the minimum distance position. Install jack stands under the tiller for support.
2. Separate the driveline into two halves and connect them to the tractor and the gearbox.
3. Place driveline halves parallel to one another to determine how much to shorten the driveline.



Figure 1. Drive Halves Placed Parallel

4. Measure from end of the upper shield to the base of the bell on the lower shield (A). Add 1-1/4" to dimension (A).

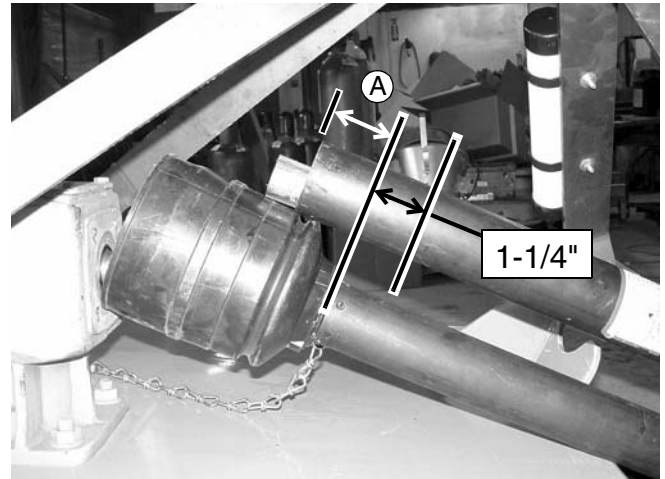

Figure 2. Determine Shield Length

5. Cut the upper shield to this overall dimension

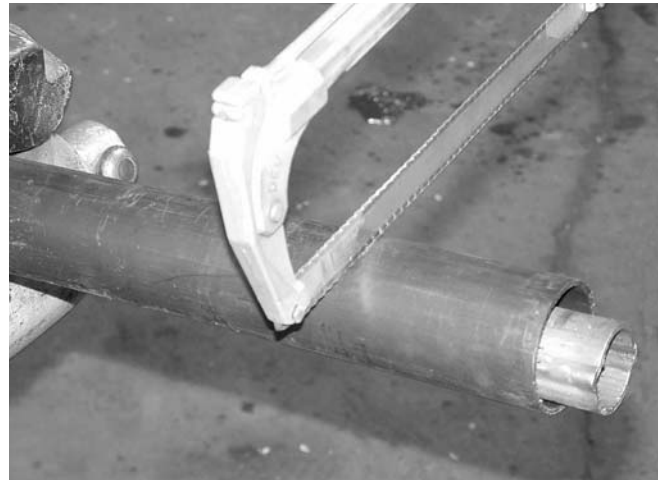

Figure 3. Cut Shield

6. Place the cut portion of the shield against the end of the shaft and use as a guide. Mark and cut the shaft.



Figure 4. Cut Shaft to Length

7. Repeat step 6 for the other half of the drive.

- File and clean the cut ends of both drive halves. Ensure the drive halves slide smoothly together.

Do not run the tractor if proper driveline engagement cannot be obtained through these methods.

Connect the driveline to tractor PTO shaft, making sure the spring-activated locking collar slides freely and locks driveline to PTO shaft.

NOTICE

■ If attaching with quick hitch, the distance between the tractor PTO and gearbox input shaft will increase. Please follow the steps as you would for a 3-point hitch to insure proper engagement.

WORKING DEPTH ADJUSTMENT

⚠ WARNING

■ Keep all persons away from operator control area while performing adjustments, service, or maintenance.

- Raise the tiller off the ground.
- Level tiller side to side. Check by measuring from the forward skid shoe pivot to the ground on each side. (Figure 5)
- Adjust, using tractor 3-point arm leveling device.

NOTE: Keep the front of the tiller parallel to the ground.

- Place two jack-stands under the tiller rotor shaft.

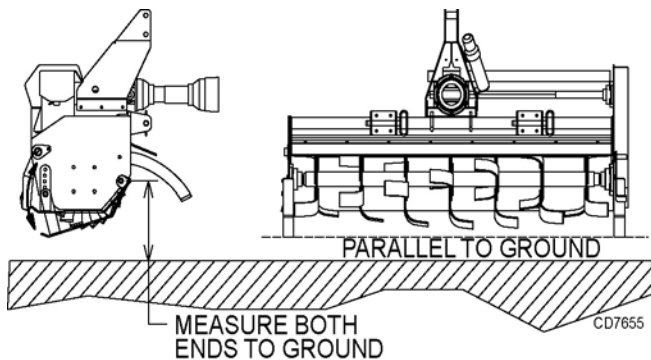

Figure 5. Leveling the Tiller

- Loosen the 1/2" cap screws that act as the front pivots to the skid shoes. Remove the 1/2" cap screws (63) that hold the rear of the skid shoes to the tiller frame.

- Adjust the skid shoe to the desired tilling depth (Figure 6). Reinstall the cap screws in the rear of the skid shoe and tighten all cap screws.

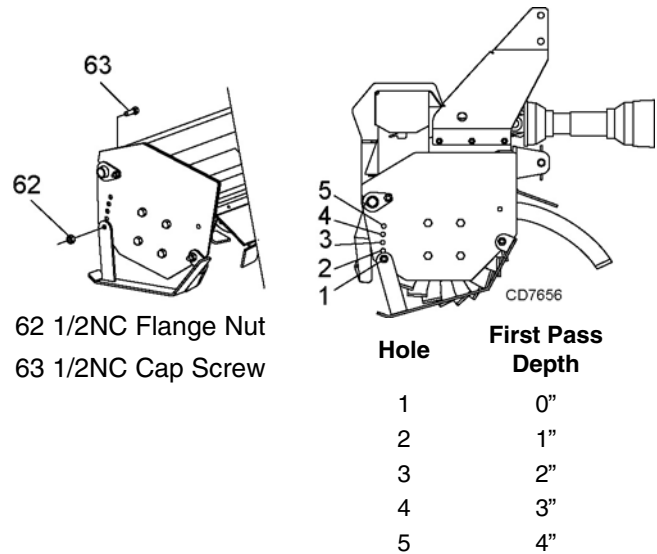

Figure 6. Tiller Depth Adjustment

NOTE: Tillage depth is dependent on ground hardness, tractor speed, skid shoe setting, and tractor hitch adjustment. Multiple passes may be necessary to achieve tillage depth.

TILLER SIDE SHIFT ADJUSTMENT

⚠ WARNING

■ Make sure parking stand is secured in the down position and skid shoes are in hole one before performing the following service work.

- Disconnect tiller from tractor.
- Measure rear tractor tire width (outside to outside).
- Calculate side shift needed. Divide rear tractor tire width by two and tiller width by two. Subtract tiller width from tractor width and add five inches. Check maximum tiller side shift capability on the specification page of this manual, page 4. The calculated side shift must be less than the maximum side shift. (Example: Tractor rear tire width = 70", TC60 Tiller = 60". $70/2 = 35$ ", $60/2 = 30$ ". $35-30 = 5$ " + 5" extra = 10" side shift.
- Loosen nuts on U-bolts on lower clevis hitch (4), U-bolts on front gearbox stand (2), and bolts at the back of the gearbox stand (2). See Figures 7 and 8.

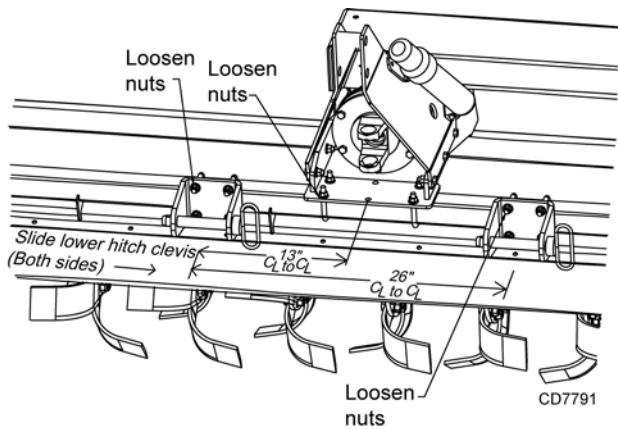

Figure 7. Clevis Hitch Adjustment

- Slide clevis hitches, A-frame/gearbox stand, and attaching rear z-clamp bracket to the desired distance.

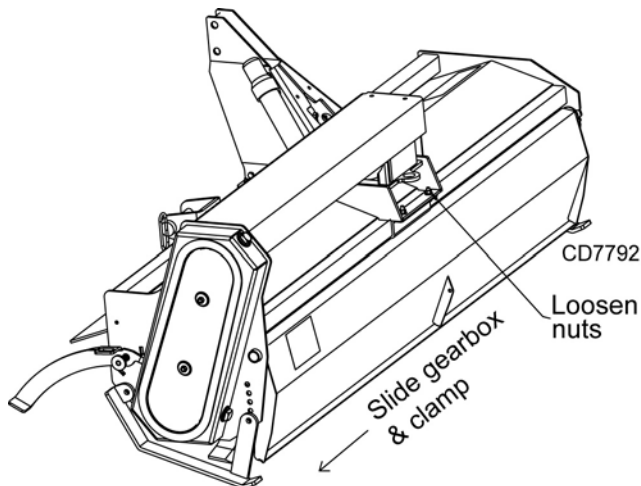

Figure 8. Gearbox and Clamp Adjustment

- Retighten the lower clevis hitch, A-frame/gearbox stand, and attaching rear z-clamp bracket hardware per the torque chart in the back of this manual.
- Reconnect tiller to the tractor.

OPERATING PROCEDURE

⚠ WARNING

■ **Only engage power when equipment is at ground operating level. Always disengage power when equipment is raised off the ground.**

Read and understand the rotary tiller and tractor operator's manuals before operating the tiller. Failure to do so may result in death, serious personal injury or property damage.

Never raise the tiller more than a few inches off the ground when traveling from job site to job site.

Shut off the engine, set brake, remove key and remove seat belt. Dismount the tractor.

Tractor Stability

⚠ WARNING

■ **A minimum 20% of tractor and equipment weight must be on the tractor front wheels when attachments are in transport position. Without this weight, front tractor wheels could raise up resulting in loss of steering. The weight may be attained with front wheel weights, ballast in tires or front tractor weights. Weigh the tractor and equipment. Do not estimate.**

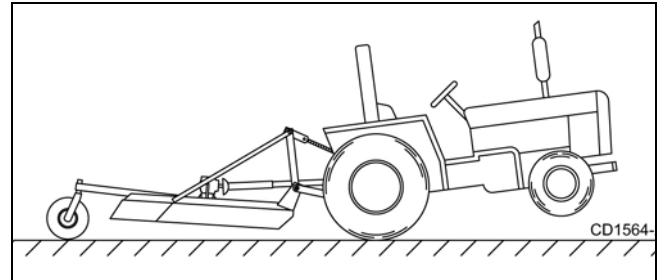

Figure 9. Tractor Stability (Typical)

Clutch Run-In

Clutch run-in must be done prior to initial use and before each season or whenever tiller has been setting idle for more than two months. See Slip Clutch Adjustment page 17 for the run-in procedure.

After you have completed the run-in of the clutch, return to the operating instructions and proceed with start-up. Failure to run the clutch in could result in premature driveline failure and warranty will be voided.

NOTE: Tillers equipped with shear bolt driveline protection do not have clutches. These drives do not require a run-in procedure prior to operation.

Start-Up Sequence

- Start tractor engine.
- Lower tiller slowly, nearly to the ground.
- Engage tractor PTO.
- Lower the tiller completely to the ground.
- Increase engine rpm to normal operating speed of 540 rpm.
- Move tractor forward. Select a slow tractor speed and increase slightly until operation is satisfactory.

Rear Shield Adjustment

The rotary tiller tailgate can be adjusted to control the tilth of the soil. The finest finish is achieved with the tailgate at the lowest adjustment. As the tailgate is raised, or adjusted up, the finish of the soil will become more coarse. Raising the tailgate reduces the amount of recirculation that occurs to the soil inside the tiller housing. If the soil conditions are very rocky, the tailgate should be run in a raised position so rocks may pass through the tiller more quickly

NOTICE

- **Do not drop tiller to the ground with the rotor turning. Sudden high speed jolts multiply stress to the driveline and can cause extreme damage.**

OPERATING TECHNIQUES

Tilling Sod and Untilled Ground

For tearing up untilled sod or conditioning compacted soils, several shallow passes will be most productive. Set the skid shoes to one of the two most shallow positions. A gear should be selected on the tractor for a slow travel speed. Progressive passes can be done at progressively faster speeds.

NOTICE

- **After tilling for the first half hour, check for loose blades and retighten any loose hardware. Follow the shutdown procedure and blocking method before checking blades.**

Previously Tilled Ground

To pulverize the topsoil and prepare a good seedbed, set the skid shoes for a tilling depth equivalent to your deepest roots. Adjust the tailgate to the fully lowered position. A tractor gear should be selected such that the tiller does not lug the engine.

PRE-OPERATION CHECK LIST

(OWNER'S RESPONSIBILITY)

- ___ Review and follow all safety rules and safety decal instructions on pages 5 through 9.
- ___ Check that all safety decals are installed and in good condition. Replace if damaged.
- ___ Check that all shields and guards are properly installed and in good condition. Replace if damaged.

- ___ Check that all hardware is properly installed and secured.
- ___ Check that equipment is properly and securely attached to tractor.
- ___ Before starting tractor, check all equipment driveline guards for damage and make sure they rotate freely on all drivelines. Replace any damaged guards. If guards do not rotate freely on drivelines, repair and replace bearings before operating.
- ___ Do not allow riders.
- ___ Make sure driveline spring-activated locking collar slides freely and is seated firmly in tractor PTO spline groove.
- ___ Keep all bystanders away from equipment working area.
- ___ Check all lubrication points and grease as instructed in the Lubrication Maintenance illustration, page 16.
- ___ Make sure tractor ROPS or ROPS CAB and seat belt are in good condition. Keep seat belt securely fastened during operation.
- ___ Check to be sure gear lube runs out of the small check plug on the side of the gearbox.
- ___ Check the condition of the tiller blades. Replace any blades that are broken or excessively worn.
- ___ Check for objects that may be wound around the tiller rotor shaft. Objects like wire, string, tall grass and weeds can build up on the rotor shaft and affect tiller operation.



OWNER SERVICE

The information in this section is written for operators who possess basic mechanical skills. If you need help, your dealer has trained service technicians available. For your protection, read and follow the safety information in this manual.

WARNING

- Keep all persons away from operator control area while performing adjustments, service, or maintenance.
- Make sure shields and guards are properly installed and in good condition. Replace if damaged.
- Make sure all safety decals are installed. Replace if damaged. (See Safety Decals section for location.)

CAUTION

- If you do not understand any part of this manual and need assistance, see your dealer.
- Always wear relatively tight and belted clothing to avoid getting caught in moving parts. Wear sturdy, rough-soled work shoes and protective equipment for eyes, hair, hands, hearing, and head; and respirator or filter mask where appropriate.

WARNING

- Before performing any service or maintenance, disconnect driveline from tractor PTO.
- Before dismounting power unit or performing any service or maintenance, follow these steps: disengage power to equipment, lower the 3-point hitch and all raised components to the ground, operate valve levers to release any hydraulic pressure, set parking brake, stop engine, remove key, and unfasten seat belt.
- Do not allow bystanders in the area when operating, attaching, removing, assembling, or servicing equipment.
- Never perform service or maintenance with engine running.

- Do not modify or alter or permit anyone else to modify or alter the equipment or any of its components in any way.

- Never go underneath equipment (lowered to the ground or raised) unless it is properly blocked and secured. Never place any part of the body underneath equipment or between moveable parts even when the engine has been turned off. Hydraulic system leak down, hydraulic system failures, mechanical failures, or movement of control levers can cause equipment to drop or rotate unexpectedly and cause severe injury or death. Follow Operator's Manual instructions for working underneath and blocking requirements or have work done by a qualified dealer.

BLOCKING METHOD

To minimize the potential hazards of working underneath the tiller, follow these procedures.

1. Jack stands with a load rating of 500 lbs or more are the only approved blocking device for this tiller. Install a minimum of two jack stands under the tiller before working underneath it.
2. Consider the overall stability of the blocked unit. Just placing jack stands underneath will not ensure your safety. The working surface must be level and solid to support the weight on the jack stands. Make sure the jack stands are stable, both top and bottom. Make sure the tiller is approximately level.
3. With the full weight of the tiller on the jack stands, test blocking stability before working underneath.
4. While the tiller is attached to the tractor, set the brakes and remove key before working underneath.
5. Securely block rear tractor wheels, in front and behind. Tighten tractor lower 3-point arm anti-sway devices to prevent side-to-side movement.

Regular preventive maintenance and immediate repair of broken or worn parts will ensure maximum efficiency and long life.

Because of the nature of the jobs the rotary tiller does, the tiller is constantly vibrating and shaking. Parts may loosen up as it is used. One of the most important functions an operator can perform is observing and inspecting the equipment for loose or worn parts to prevent further damage or excessive downtime.

LUBRICATION INFORMATION

1. Do not let excess grease collect on or around parts, particularly when operating in sandy areas.
2. See Figure 10 for lubrication points and frequency of lubrication based on normal operating conditions. Severe or unusual conditions may require more frequent lubrication.
3. Use a lithium grease of #2 consistency with a MOLY (molybdenum disulfide) additive for all locations unless otherwise noted. Be sure to clean fittings thoroughly before attaching grease gun. Two good pumps of most guns is sufficient when the lubrication schedule is followed.

CHAIN MAINTENANCE

The drive chain should be inspected every 50 hours. New chain has a tendency to stretch, so it is necessary to check the chain tension to prevent flopping around, thus causing potential problems. Chain tension is pre-set with the torsion spring. If the chain becomes excessively loose, it may be necessary to remove one link (two pitches). If unable to reassemble, add an offset link to lengthen the chain.

NOTICE

■ **Replacement chain should be only high quality original equipment chain for longer life.**

When being stored for a long period or at end of season, change the oil, adding .8 quarts #00 gear fluid, and rotate the roller several times allowing the chain to be coated with lubricant, enhancing chain life. Rotate the roller periodically to maintain lubrication.

PTO DRIVE LINES

Periodically check the yokes on front PTO. Make sure the bolts and nuts are tight and the yoke is not moving on the shaft. PTO shafts and U-joints should be sparingly lubricated monthly.

SPROCKETS

Sprockets should be checked to be sure hex bolt is tight and the sprocket cannot move on the shaft.

QUALIFIED TECHNICIAN MAINTENANCE

GEARBOX LUBRICATION

The gearbox is almost maintenance-free, but should be checked quarterly to be sure that the oil level is maintained at half full. Use plug located halfway up back face of gearbox to check/fill oil. A high quality gear oil with a viscosity index of 80W or 90W and an API service rating of GL-4 or -5 is recommended for use in the gearbox. Oil should be changed after the first 30 hours or 30 days of operating. Then, normal change should be adequate. In the case of seasonal usage, it is best to change the oil at the end of the season to remove moisture and corrosive contaminants.

BEARING LUBRICATION

Highest quality bearings are used on the tiller. Only triple-seal bearings are used on the rotor shaft, which operates down in the dirt. Lubrication of the bearings will vary considerably with conditions. As a rule, bearings should be under-lubricated rather than over-lubricated. Over-lubrication can cause seals to blow out.

NOTICE

■ **Replacement bearings should be only high quality original equipment bearings for longer life.**

Install new complete bearing housing if needed or just replace the bearing insert. The shafts should be straight, free of burrs, and up to size. If shaft is worn, replace it prior to completing assembly.

DRIVELINE LUBRICATION

1. Lubricate the driveline slip joint every 8 hours of operation. Failure to maintain proper lubrication could result in damage to u-joints, gearbox, and driveline.
2. Lower tiller to ground, disconnect driveline from tractor PTO shaft, and slide halves apart. Do not disconnect the halves from each other.
3. Apply a bead of grease completely around male half where it meets female half. Slide drive halves over each other several times to distribute grease.
4. Apply one pump of grease to each driveline u-joint grease fitting.
5. Apply one pump of grease to each of the plastic driveline shield bearings.
6. If using a shear pin drive, lubricate the shear yoke with grease to prevent galling.

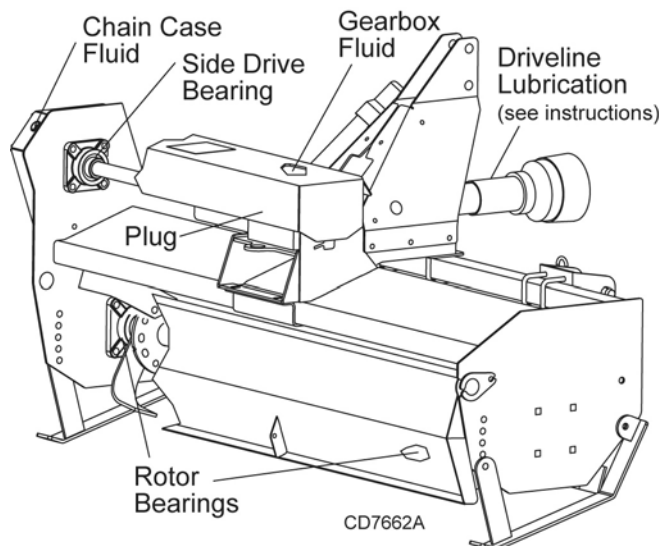

Figure 10. Lubrication Points

SLIP CLUTCH ADJUSTMENT

1. Turn off tractor engine and remove key.
2. Loosen nuts on springs until the springs can rotate freely, yet remain secure on the bolts.
3. Mark outer plates of slip-disc clutch as shown in Figure 11.
4. Securely attach implement to the tractor and start the tractor.
5. Engage PTO for several seconds then quickly disengage it.
6. Turn tractor off and remove key.
7. The friction lining plates should have "slipped", or moved. Check the marks placed on the outer plates of the slip-disc clutch in step 3 to make sure this is the case.
8. If clutch does not slip, check assembly for oil, grease and debris. Clean if necessary.
9. Reassemble clutch and tighten bolts no more than 1/8 of a turn at a time until desired setting of 1.25" compressed spring length.
10. If excessive slippage continues, check lining plates for excessive wear. They are 1/8" thick when new and should be replaced after 1/32" of wear to ensure proper operation.

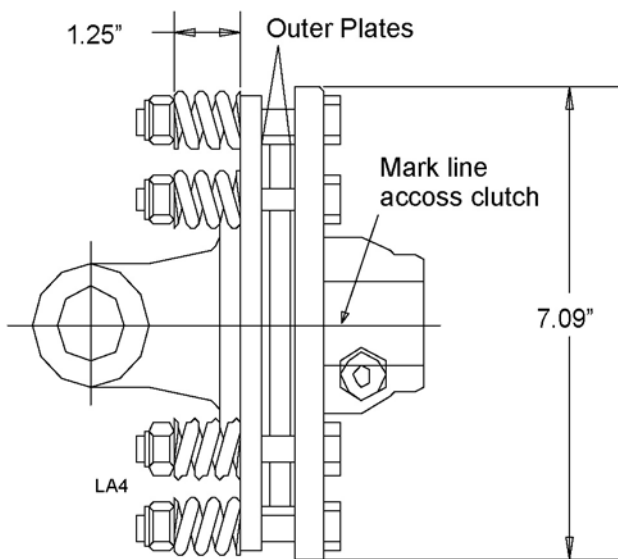

Figure 11. Slip Clutch Adjustment

DRIVELINE SHEAR BOLT REPLACEMENT

■ Always use approved M8 x 50 mm class 8.8 shear bolt as a replacement part. Using a hardened bolt or shear pin may result in damage to driveline or gearbox.

1. Remove damaged shear bolt from yoke on input shaft of tiller gearbox.
2. Rotate driveline to align holes in yoke and shaft. Install shear bolt and secure the lock nut.

Cleaning

After Each Use

- Remove large debris such as clumps of dirt, grass, crop residue, etc. from machine.
- Inspect machine and replace worn or damaged parts.
- Replace any safety decals that are missing or not readable.

Periodically or Before Extended Storage

- Clean large debris such as clumps of dirt, grass, crop residue, etc. from machine.
- Remove the remainder using a low-pressure water spray.
 1. Be careful when spraying near scratched or torn safety decals or near edges of decals as water spray can peel decal off surface.
 2. Be careful when spraying near chipped or scratched paint as water spray can lift paint.
 3. If a pressure washer is used, follow the advice of the pressure washer manufacturer.
- Inspect machine and replace worn or damaged parts.
- Sand down scratches and the edges of areas of missing paint and coat with Woods spray paint of matching color (purchase from your Woods dealer).
- Replace any safety decals that are missing or not readable (supplied free through your Woods dealer). See Safety Decals section for location drawing.

Blade Installation

Four Blade Installation

1. Remove any burrs on flanges generated from blades that have slipped.
2. Start blade assembly with first blade installed over the double slots (1).
NOTE: Blade cutting edges should face the direction of rotation.
3. Install bolt heads against blades and flange nuts against rotor flange.
4. Proceed by installing opposite blade to opposite side of flange, skipping one hole between each blade.
5. Completed assembly should have an empty hole between blades. Blades should sweep over the flange, not away from the flange.
6. Torque bolt head to 85 lbs-ft with a mechanical torque wrench.

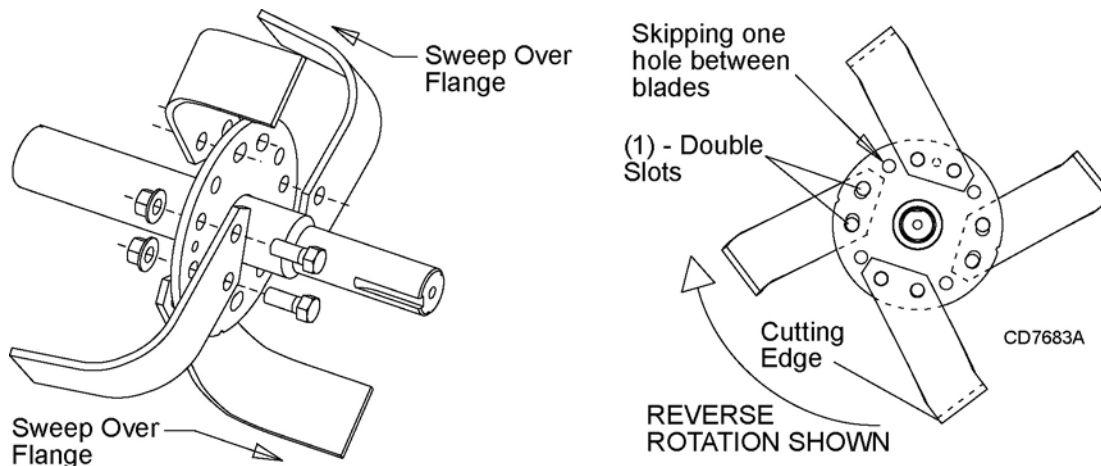

Figure 12. Four Blade Installation

Six Blade Installation

1. Remove any burrs on flanges generated from blades that have slipped.
2. Start blade assembly with first blade installed over one slot (1) and one hole (2).
NOTE: Blade cutting edges should face the direction of rotation.
3. Install bolt heads against blades and flange nuts against rotor flange.
4. Proceed by installing opposite blade to opposite side of flange using every hole.
5. Completed assembly should **not** have empty holes between blades. Blades should sweep over the flange, not away from the flange.
6. Torque bolt head to 85 lbs-ft with a mechanical torque wrench.

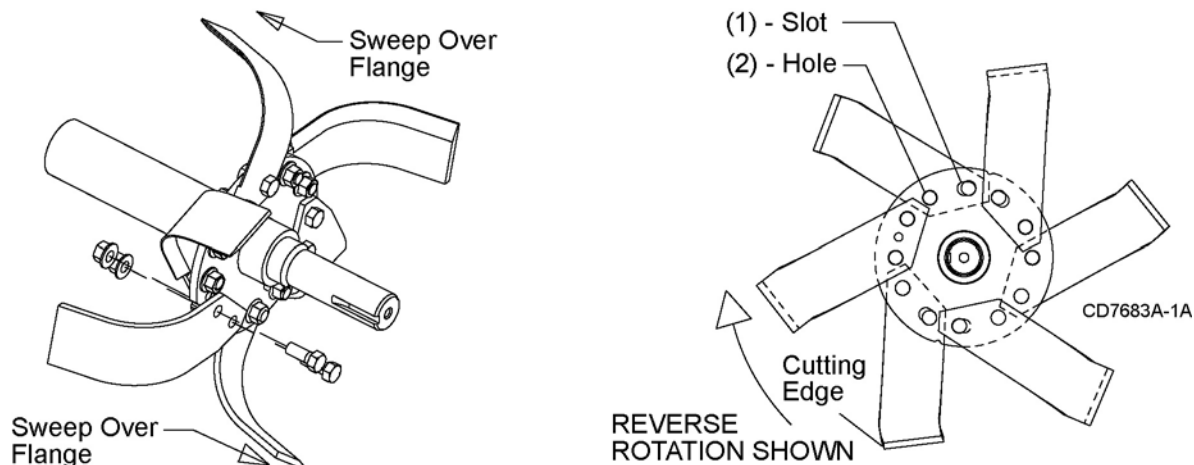

Figure 13. Six Blade Installation

TROUBLE SHOOTING

PROBLEM	POSSIBLE CAUSE	SOLUTION
Rotor will not turn.	Tractor PTO not engaged.	Check control lever.
	Clutch friction discs worn (Slip-Clutch drive only).	Check and replace.
	Shear bolt sheared (Shear bolt drive only).	Install new shear bolt.
	Obstruction between rotor and frame.	Check and clear obstruction.
	Chain broken.	Replace chain.
	Gearbox damaged.	Check that output shaft rotates.
Tiller won't cut.	Skid shoes set too shallow.	Raise skid shoes one hole.
	Blade orientation does not match tiller rotation.	Reverse all blades.
	If shear bolt drive used, check shear bolt.	Replace if broken.
Tiller stalls when tilling.	Skid shoes set too deep.	Lower skid shoes one hole.
Tilled soil is too fine.	Too much regrinding.	Raise tailgate or increase travel speed.
Tilled soil is too coarse.	Too little regrinding.	Lower tailgate or decrease travel speed.
Grass and Weeds wrapping rotor.	Grass too tall.	Mow grass before tilling.
Oil leaks.	Worn or damaged seal.	Inspect and replace.
	Loose or damaged hoses or connections.	Check for leaks and repair or replace.
	Worn or damaged housing.	Inspect and replace if required.
	Wrong type of grease installed in chain case.	Use #00 semi-fluid grease.
Excessive Noise	Rotor blade hardware is loose or missing.	Tighten loose blade hardware. Replace missing hardware.

DEALER SERVICE

The information in this section is written for dealer service personnel. The repair described here requires special skills and tools. If your shop is not properly equipped or your mechanics are not properly trained in this type of repair, you may be time and money ahead to replace complete assemblies.

WARNING

■ Before working underneath, disconnect drive-line, raise tiller, lock in transport position, and block tiller securely. Hydraulic system leak down and failure of mechanical or hydraulic system can cause equipment to drop.

■ Keep all persons away from operator control area while performing adjustments, service, or maintenance.

CAUTION

■ Always wear relatively tight and belted clothing to avoid getting caught in moving parts. Wear sturdy, rough-soled work shoes and protective equipment for eyes, hair, hands, hearing, and head; and respirator or filter mask where appropriate.

GEARBOX MAINTENANCE

NOTE: Read this entire section before starting any repair. Many steps are dependent on each other.

1. Fill gearbox with SAE 80W or 90W gear lube until it runs out the side level plug.

NOTE: Repair to this gearbox is limited to replacing bearings, seals, and gaskets. Replacing gears, shafts, and a housing is not cost effective. Purchasing a complete gearbox is more economical.

2. Inspect gearbox for leakage and bad bearings. Leakage is a very serious problem and must be corrected immediately. Bearing failure is indicated by excessive noise and side-to-side or end-play in gear shafts.

Seal Replacement

Recommended sealant for gearbox repair is Permatex® Aviation 3D Form-A-Gasket or equivalent.

Leakage can occur at the horizontal gaskets and shaft seals. These can be repaired without removing the gearbox from the tiller.

Seal Installation

NOTE: Proper seal installation is important. An improperly installed seal will leak.

1. Clean area in housing where seal outer diameter (OD) seats. Apply a thin coat of Permatex.
2. Inspect area of shaft where seal seats. Remove any burrs or nicks with an emery cloth.
3. Lubricate gear shaft and seal lips.
4. Place seal squarely on housing, spring-loaded lip toward housing. Select a piece of pipe or tubing with an OD that will sit on the outside edge of the seal but will clear the housing. Tubing with an OD that is too small will bow seal cage and ruin seal.
5. Carefully press seal into housing, avoiding distortion to the metal seal cage.

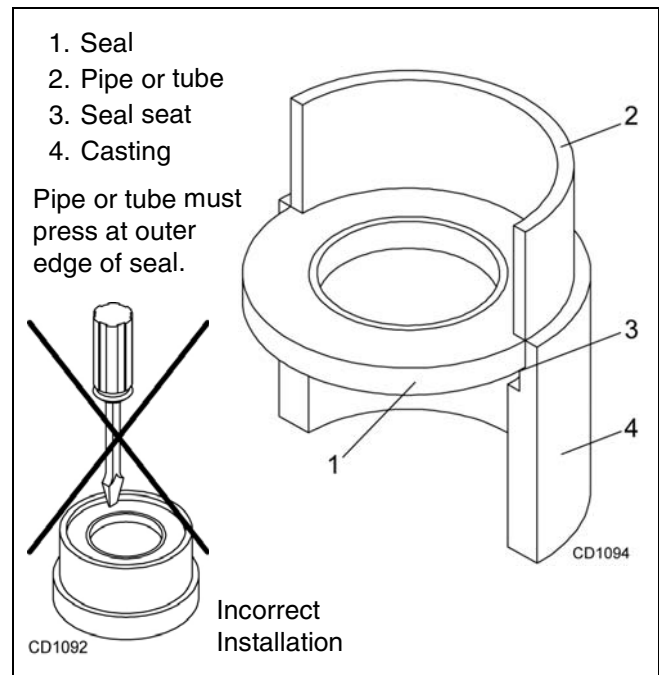

Figure 14. Seal Installation

Input Shaft Repair

1. Disconnect and remove the driveline from the gearbox.
2. Remove drain plug and drain gear lube from the gearbox.
3. Remove mast plates from the tiller frame.
4. Remove shaft seal. Replace with new seal (see Seal Installation, page 20).

NOTE: Distortion to seal cage or damage to seal lip will cause seal to leak.

5. Reinstall drain plug and remove fill plug. Fill gearbox with SAE 80W or 90W gear lube until it runs out the level plug.

Output (Hollow) Shaft Repair

1. Disconnect and remove the driveline from the gearbox.
2. Remove drain plug and drain gear lube from the gearbox.
3. Remove the gearbox side drive shield.
4. Remove the drain plug from the chain case to drain the gear fluid.
5. Remove chain case cover.

6. Remove retaining bolt and washer from the top sprocket.
7. Release the tension from the chain, Figure 15, and remove the top sprocket and sleeve from the side drive shaft.
8. Loosen the set screw on the side drive shaft bearing. This bearing is located inboard of the top sprocket, at the top of the chain case. Use a hammer and a punch to unlock the locking collar. This is achieved by putting the point of the punch in the relief of the collar and drive it in the direction opposite of normal rotation for the tiller.
9. With the sprocket removed and the locking collar freed, the side drive shaft can be removed through the opposite side of the tiller gearbox.
10. The faulty shaft seal can be removed and replaced with a new seal (refer to Seal Installation, page 20)
11. Follow the instructions 1 through 9 in reverse for reassembly. Use blue Loctite® on bolts used to retain sprockets on shafts. Make sure top and bottom sprockets and chain tensioner are aligned with each other. Shaft end should be recessed from sprocket outside face by .03 inches on top and bottom sprockets.

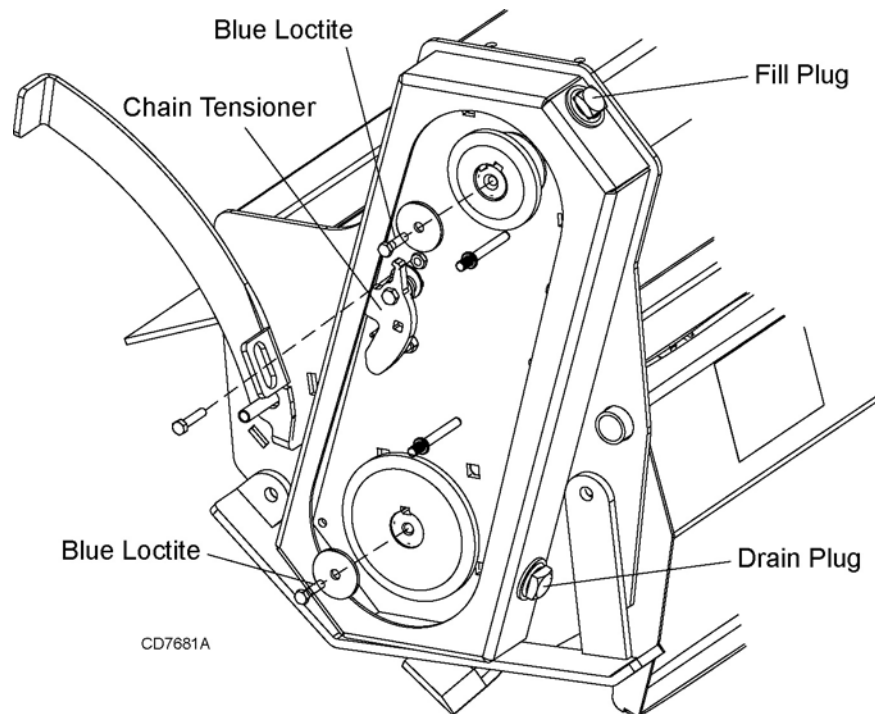

Figure 15. Release Chain Tension

UNIVERSAL JOINT REPAIR

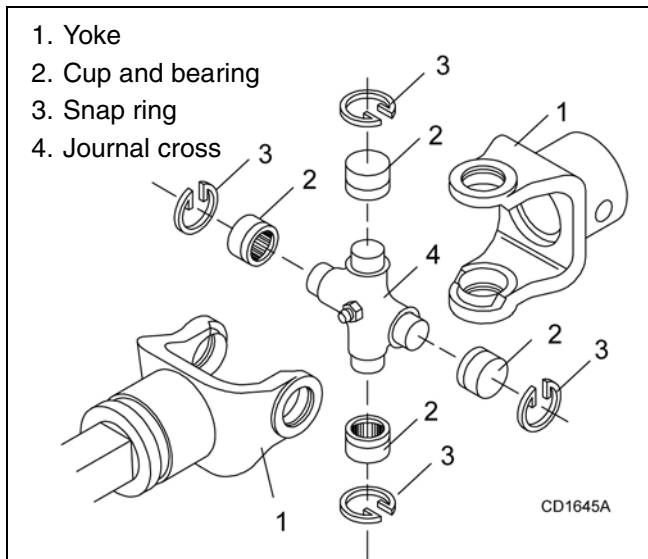

Figure 16. Universal Joint Parts Breakdown

U-Joint Disassembly

1. Remove external snap rings from yokes in four locations as shown in Figure 17.

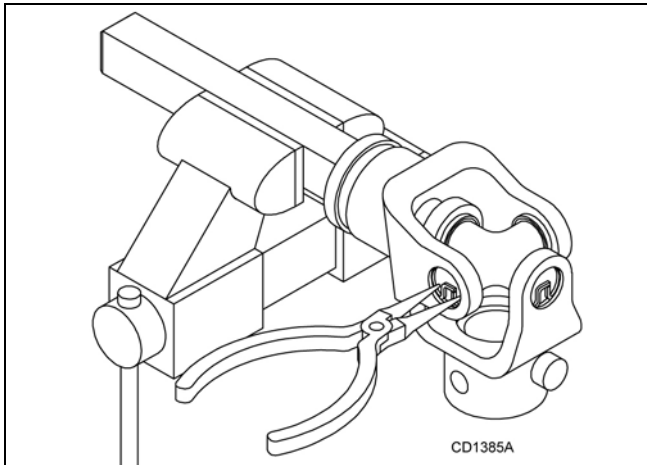

Figure 17. Remove Snap Ring

2. With snap rings removed, support drive in vise, hold yoke in hand and tap on yoke to drive cup up out of yoke. See Figure 18.

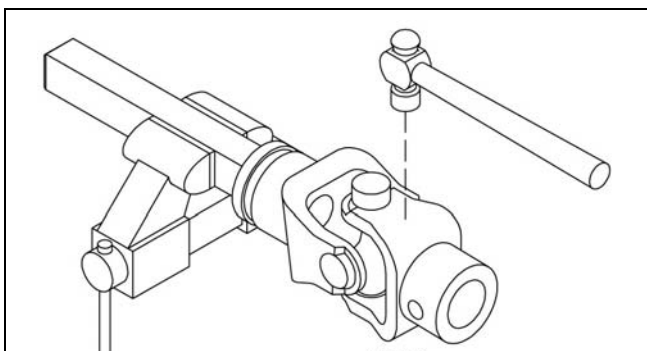

Figure 18. Remove Cups

3. Clamp cup in vise as shown in Figure 19 and tap on yoke to completely remove cup from yoke. Repeat Step 2 and Step 3 for opposite cup.

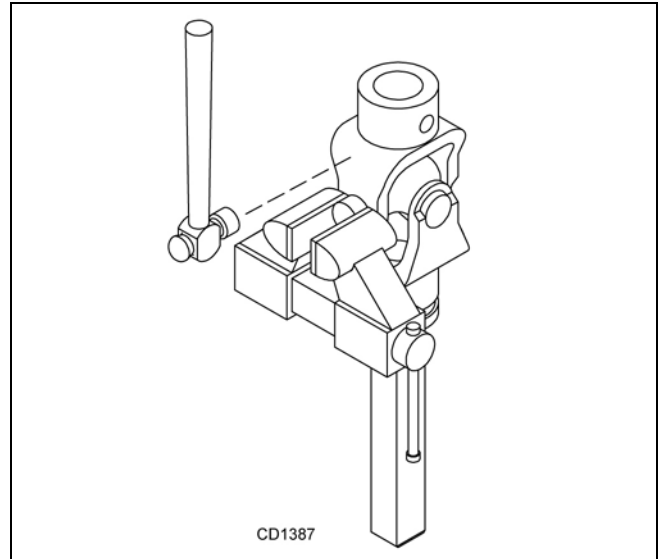

Figure 19. Remove Cups

4. Place universal cross in vise as shown in Figure 20 and tap on yoke to remove cup. Repeat Step 3 for final removal. Drive remaining cup out with a drift and hammer.

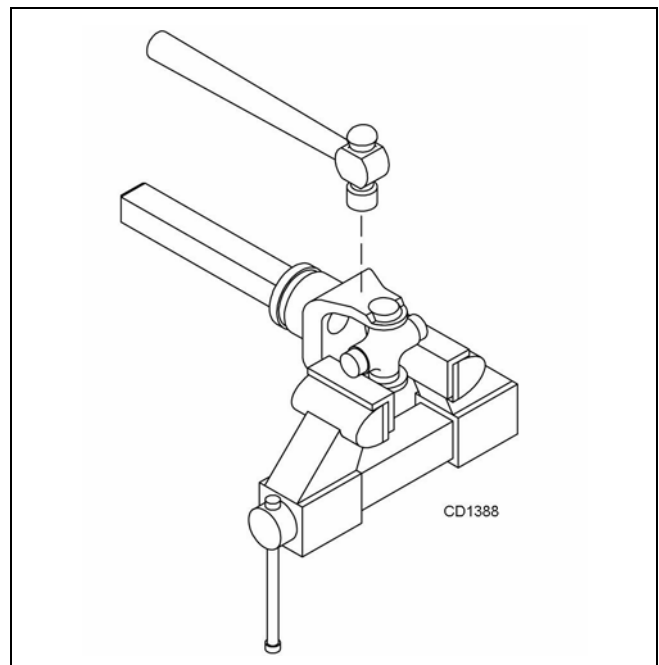

Figure 20. Remove Cups

U-Joint Assembly

1. Place seals securely on bearing cups. Insert cup into yoke from outside and press in with hand pressure as far as possible. Insert journal cross into bearing cup with grease fitting away from shaft. Be careful not to disturb needle bearings. Insert another bearing cup directly across from first cup and press in as far as possible with hand pressure.
2. Trap cups in vise and apply pressure. Be sure journal cross is started into bearings and continue pressure with vise, squeezing in as far as possible. Tapping the yoke will help.
3. Seat cups by placing a drift or socket (slightly smaller than the cup) on cup and rap with a hammer. See Figure 21. Install snap ring and repeat on opposite cup
4. Repeat Step 1 and Step 2 to install remaining cups in remaining yoke.
5. Move both yokes in all directions to check for free movement. If movement is restricted, rap on yokes sharply with a hammer to relieve any tension. Repeat until both yokes move in all directions without restriction.

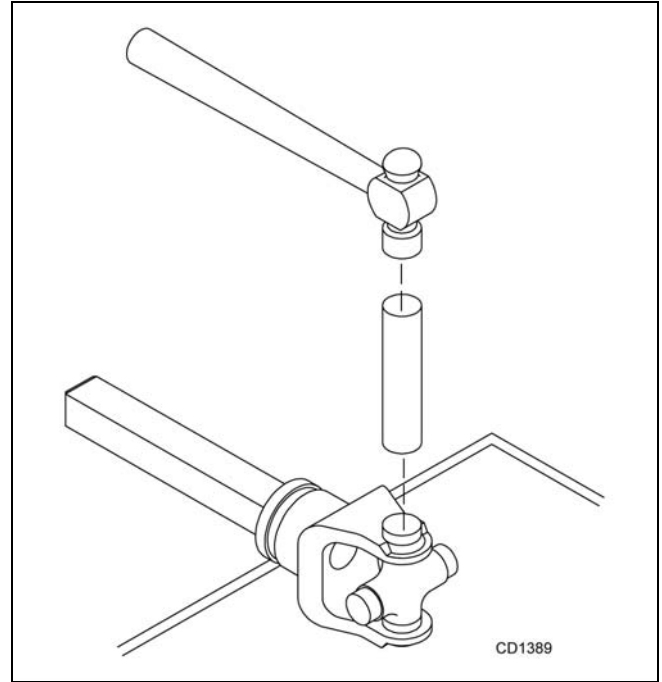

Figure 21. Install Cups



ASSEMBLY

Assembly of this rotary tiller is the responsibility of the WOODS dealer. It should be delivered to the owner completely assembled, lubricated and adjusted for normal conditions.

WARNING

- Do not allow bystanders in the area when operating, attaching, removing, assembling, or servicing equipment.
- Do not modify or alter or permit anyone else to modify or alter the equipment or any of its components in any way.

CAUTION

- Always wear relatively tight and belted clothing to avoid getting caught in moving parts. Wear sturdy, rough-soled work shoes and protective equipment for eyes, hair, hands, hearing, and head; and respirator or filter mask where appropriate.

SET-UP INSTRUCTIONS

The rotary tiller is shipped partially assembled. Assembly will be easier if components are aligned and loosely assembled before tightening hardware. See "Bolt Torque Chart" on page 37 for recommended torque values.

Complete the Pre-Delivery and Delivery Check Lists on page 26 when assembly is complete.

Select a suitable working area. Refer to illustrations, accompanying text, parts lists, and exploded view drawings.

For reference, front, back, left, and right directions are determined by sitting in the tractor operator's seat.

DISASSEMBLE SHIPPING UNIT

It is advisable to have a mechanical lifting device to facilitate uncrating.

Be careful of nails in boards when uncrating.

1. Remove all parts that are wired and strapped to tiller and/or crate.
2. Remove top, sides, and ends of crate.
3. Remove front rubber shield from the bottom of the crate (reverse rotation models only).
4. Remove lag screws from L-shaped shipping brackets. Remove L-brackets from the tiller. Be sure to save the mounting hardware for later use.
5. Remove tiller assembly from crate base.

6. Remove loose nails from boards and dispose of crate according to local codes.

ASSEMBLY PROCEDURES

Required tools: 9/16", 3/4", 1-1/8" combination wrenches, sockets, torque wrench, and jack stands.

1. Lower skid shoes to lowest position and stand tiller upright.
2. Use jack stands to support the front frame tube with tiller sitting on the ground.
3. Install parking stand (33) and spring assembly to tiller frame using 1/2NC x 3-1/4 cap screw (67) and flange nut (62).
4. Unbolt lower hitch clevises (34), rotate 90 degrees, and re-install in operating position, 26" from center to center. Figure 23, page 25.
5. Install driveline (8) to gearbox input shaft.
6. Attach right mast plate (27) and driveline holder (80) to gearbox frame using 3/8NC x 1-1/4 serrated flange screws (83) and flange whiz nuts (60). Attach driveline holder on outside of mast plate using the front two holes. Use 3/8NC x 1 serrated flange screws (55) and flange whiz nuts (60) to attach mast plates (27 & 28) to gearbox stand in remaining holes Figure 23, page 25.
7. Install CAT 1 quick hitch sleeve (70) using 3/4NC x 3-1/2 cap screw (68) and lock nut (69). Install in the lower hole in the top of the mast plates.
8. Attach driveline tether chain to the tiller hitch frame.
9. Attach tailgate chain to lug on tailgate using packing slip instructions in hardware bag. Thread the chain through the keyhole slot on the top safety shield support. Secure the chain by sliding the desired link into the narrow portion of the keyhole slot.

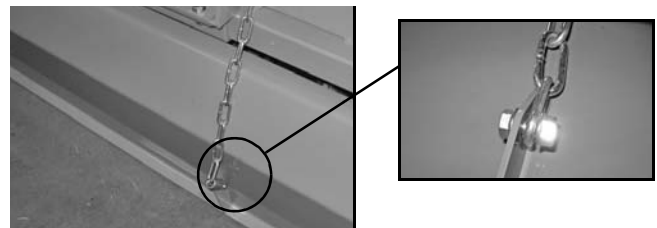

Figure 22. Attaching Tailgate Chain

10. Attach front rubber deflector and clamp bar using 5/16NC x 1 carriage bolts (53) and flange whiz nuts (54). (Reverse models only)
11. Fill gearbox with SAE 80W or 90W gear lube until it runs out the center side level plug.

NOTE: Chain case has .8 quarts of 00 grease installed at factory. This grease is very viscous and will stick to chain at 70°F.

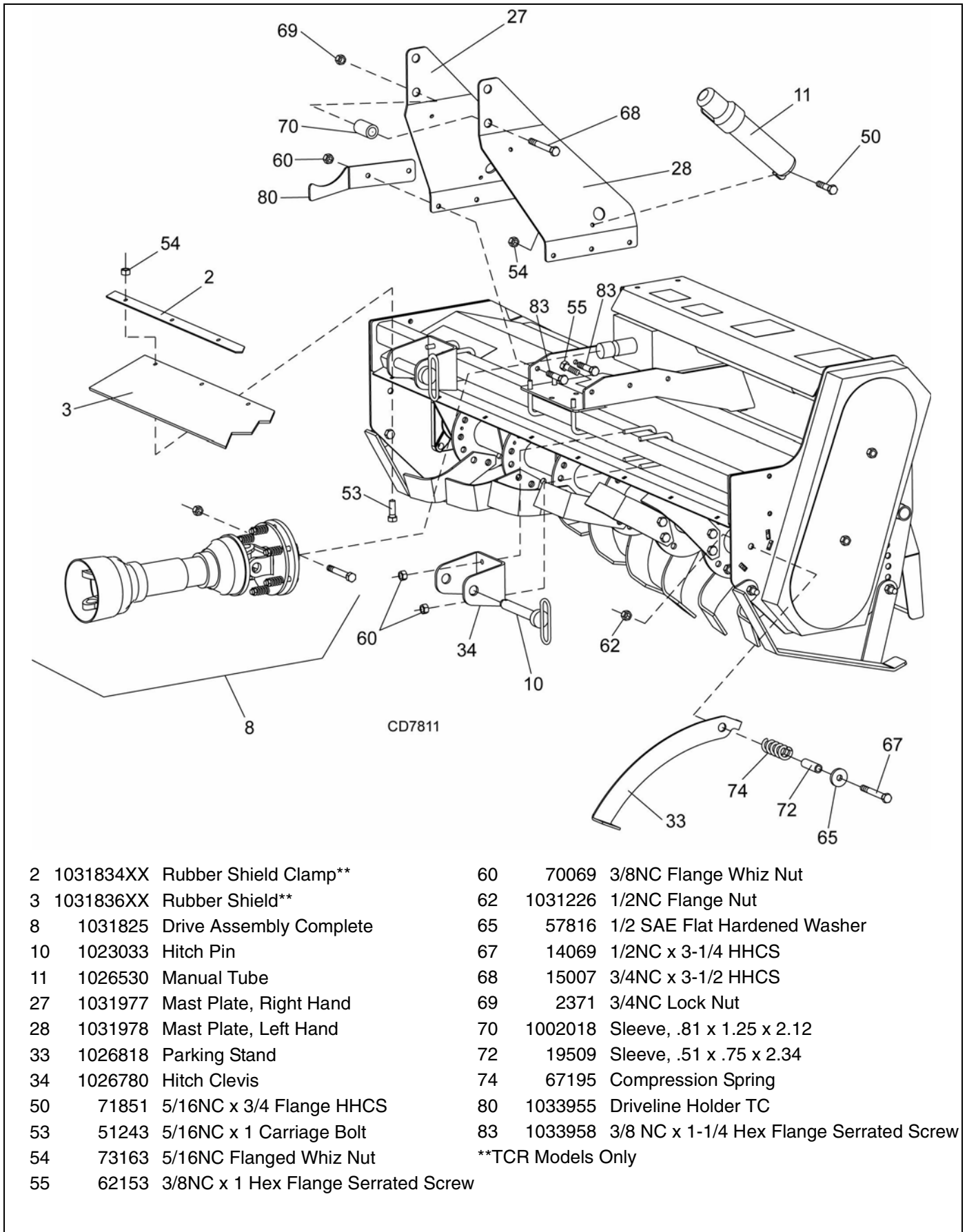

Figure 23 . Crate Assembly

DEALER CHECK LISTS

PRE-DELIVERY CHECK LIST

(DEALER'S RESPONSIBILITY)

Inspect the equipment thoroughly after assembly to make sure it is set up properly before delivering it to the customer.

The following check list is a reminder of points to inspect. Check off each item as it is found satisfactory, corrections are made, or services are performed.

- ___ Check that all safety decals are installed and in good condition. Replace if damaged.
- ___ Check that all shields and guards are properly installed and in good condition. Replace if damaged.
- ___ Check all bolts to be sure they are properly torqued
- ___ Check and grease all lubrication points as identified in the Lubrication Maintenance illustration, page 16.
- ___ Check the level of gearbox fluid before delivery. Service, if required, as specified on page 16.
- ___ Check that blades have been properly installed

DELIVERY CHECK LIST

(DEALER'S RESPONSIBILITY)

- ___ Show customer how to make adjustments and select proper PTO speed.
- ___ Instruct customer how to lubricate and explain importance of lubrication.

- ___ Point out the safety decals. Explain their meaning and the need to keep them in place and in good condition. Emphasize the increased safety hazards when instructions are not followed.
- ___ Point out all guards and shields. Explain their importance and the safety hazards that exist when not kept in place and in good condition.
- ___ Present Operator's Manual and request that customer and all operators read it before operating equipment. Point out the manual safety rules, explain their meanings, and emphasize the increased safety hazards that exist when safety rules are not followed.
- ___ Explain to customer the potential crushing hazards of going underneath raised equipment. Instruct customer that service work does not require going underneath unit and never to do so.
- ___ Explain to customer that when equipment is transported on a road or highway, safety devices should be used to give adequate warning to operators of other vehicles.
- ___ Inform customer to operate PTO at 540 rpm maximum.
- ___ Explain to customer the importance of having the correct PTO driveline length so that it does not bottom out or come apart. Explain that it must be checked as instructed in the manual whenever using a different tractor.
- ___ Show customer the safe, proper procedures to be used when mounting, dismounting, and storing equipment.

WOODS

PARTS INDEX

Rotary Tillers

TC/TCR60 TILLER ASSEMBLY	28-29
TC/TCR68 TILLER ASSEMBLY	30-31
TC/TCR74 TILLER ASSEMBLY	32-33
DRIVE ASSEMBLY.....	34-35
GEARBOX ASSEMBLY	36

TC60/TCR60 ROTARY TILLER ASSEMBLY

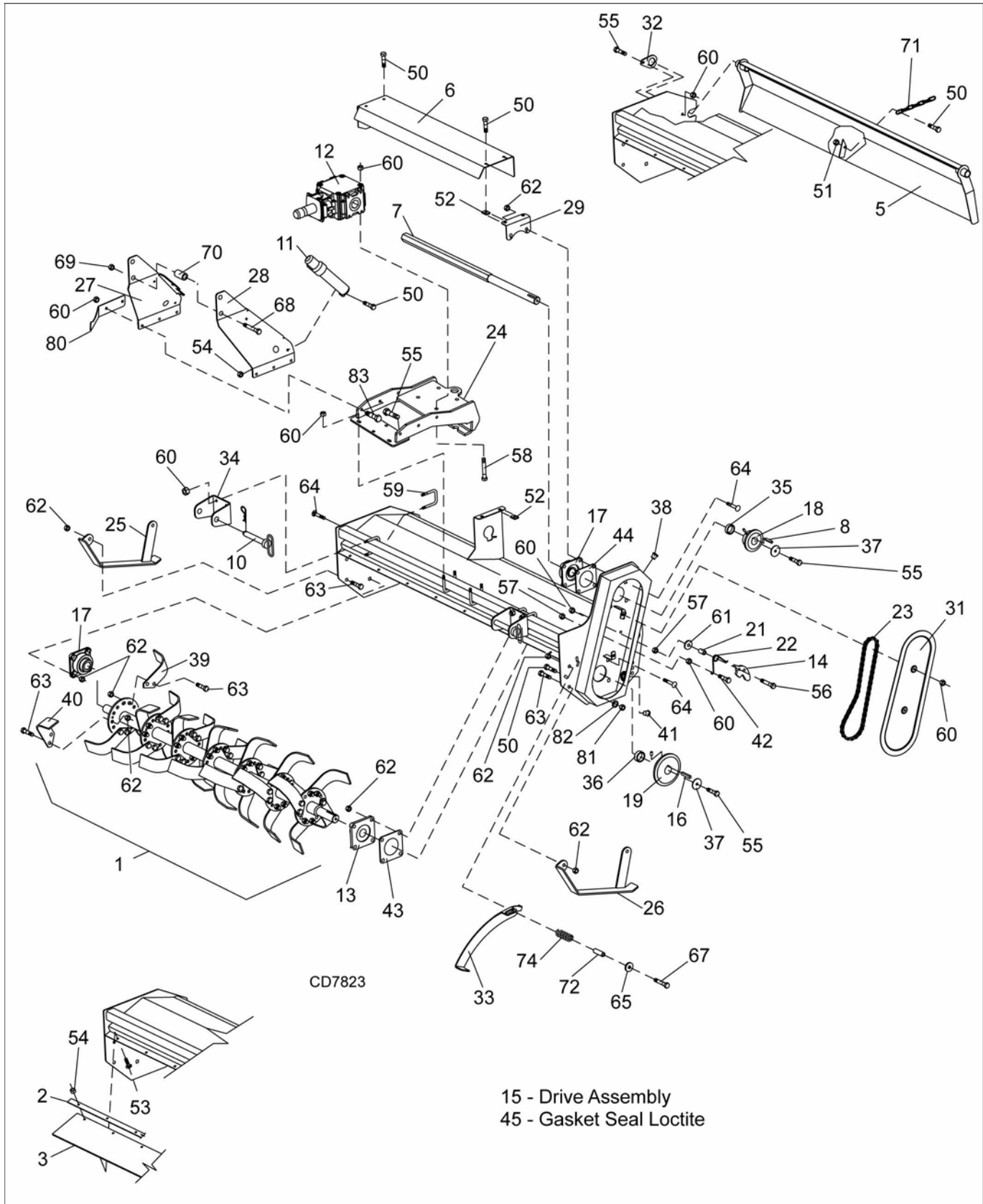

28 Parts

(Rev. 3/1/2012)

MAN0813 (3/17/2010)

TC60/TCR60 ROTARY TILLER ASSEMBLY

REF	PART NO	QTY	DESCRIPTION	REF	PART NO	QTY	DESCRIPTION
1	102676560	1	Rotor Shaft	41	4510	1	1/2 Pipe Plug
2	103183460	1	Clamp, Rubber Shield (TCR Models Only)	42	976 *	1	3/8NC x 1-1/2 HHCS GR5
3	103183660	1	Rubber Shield (TCR Models Only)	43	1031951	1	Gasket, 1-1/2 Bearing
5	1031982	1	Tailgate	44	1031953	1	Gasket, 1-5/8 Bearing
6	1031979	1	Top Shield	45	1031940	1	Gasket Seal Loctite, 598 70ml
7	103192260	1	Hex Drive Shaft	50	71851 *	4	5/16NC x 3/4 Flange HHCS
10	1023033	2	Hitch Pin	51	14139 *	1	5/16NC Flange Lock Nut ZP
11	1026530	1	Manual Tube	52	74047	4	5/16-18 U-Tapered Spring Nut
12	1032606	1	Gearbox, 1.46:1	53	51243 *	10	5/16NC x 1 Carriage Bolt GR5 ZP (Manual Tube and TCR Models Only)
13	1026790	2	Bearing, 1.50 Dia, 4-Bolt Flange -or-	54	73163	10	5/16NC Flanged Whiz Nut YD (Manual Tube and TCR Models Only)
13	1032608	2	1.50 Dia, Bearing Insert with collar	55	62153	9	3/8NC X 1 Hex Flange SRTD Screw
14	1026803	1	Chain Tensioner	56	300157 *	1	3/8NC x 2-1/4 HHCS GR5 ZP
15	-----	1	Drive Assembly Complete (Not Shown - See page 34 and 35.)	57	6698 *	2	3/8NC Lock Nut ZP
16	1031228	2	Key 3/8 x 3/8 x 1-1/2	58	57816 *	4	1/2 SAE Flat Washer, Hardened
17	1031907	1	Bearing, 1.62 Dia, 4-Bolt Flange -or-	59	35646	6	3/8 U-Bolt
17	1032609	1	1.62 Dia, Bearing Insert with collar	60	70069	21	3/8NC Flanged Whiz Nut
18	1026806	1	Sprocket 80B 11T	61	2210 *	1	7/16 Flat Washer
19	1026807	1	Sprocket 80B 17T	62	1031226	73	1/2NC Flange Nut
21	1031833	1	Sleeve, .75 x .44 x .81	63	1031925 *	64	1/2NC x 1-1/4 HHCS GR5 ZP
22	1031841	1	Torsion Spring, LT Hand - TCR	64	29893 *	10	1/2NC x 1-1/2 CRG Bolt GR5 ZP
	1031828	1	Torsion Spring, RT Hand - TC	65	854 *	1	1/2 Flat Washer
23	1031829	1	Chain #80 x 46 Continuous	66	12735	2	1/2NC x 1-3/4 CRG Bolt GR5 ZP
24	1033033	1	Gearbox Mount	67	14069 *	1	1/2NC x 3-1/4 HHCS
25	1026800	1	Skid Shoe, Right Hand	68	15007 *	1	3/4NC x 3-1/2 HHCS GR5 ZP
26	1026801	1	Skid Shoe, Left Hand	69	2371 *	1	3/4NC Lock Nut ZP
27	1026784	1	Mast Plate, Right Hand	70	1002018	1	Sleeve, .81 x 1.25 x 2.12
28	1026785	1	Mast Plate, Left Hand	71	1031958	1	2/0 STR Link Chain - 15 Link
29	1026791	1	Shield Mount	72	19509	1	Sleeve, .51 x .75 x 2.34
31	1031240	1	Chain Case Cover	74	67195	1	Compression Spring
32	1026802	1	Tailgate Lock Plate	75	1031974	--	TC Model Decal Set
33	1026818	1	Parking Stand	76	1031975	--	TCR Model Decal Set
34	1026780	2	Hitch Clevis	77	1031976	--	Tiller Safety Decal Set
35	1031948	1	Spacer 1.53 x 1.87 x .62	78	1033749	--	00 Grease, 1 quart (Not Shown)
36	1031946	1	Spacer 1.656 x 2.00 x .75	79	14350	4	3/8 NC Flange Lock Nut
37	1031950	2	Washer, 10ga	80	1033955	1	Driveline Holder TC
38	11975	1	1/2 NPT Vent Plug	81	14139 *	1	Nut, Lock 5/16NC Flange
39	1031934	14	Speed Blade, Right Hand	82	1033959	1	Washer, 5/16 Neoprene
40	1031935	14	Speed Blade, Left Hand	83	1033958	2	3/8NC x 1-1/4 Hex Flange SRTD Screw

HHCS

Hex Head Cap Screw

*

Obtain Locally

(Rev. 3/1/2012)

MAN0813 (3/17/2010)

Parts 29

TC68/TCR68 ROTARY TILLER ASSEMBLY

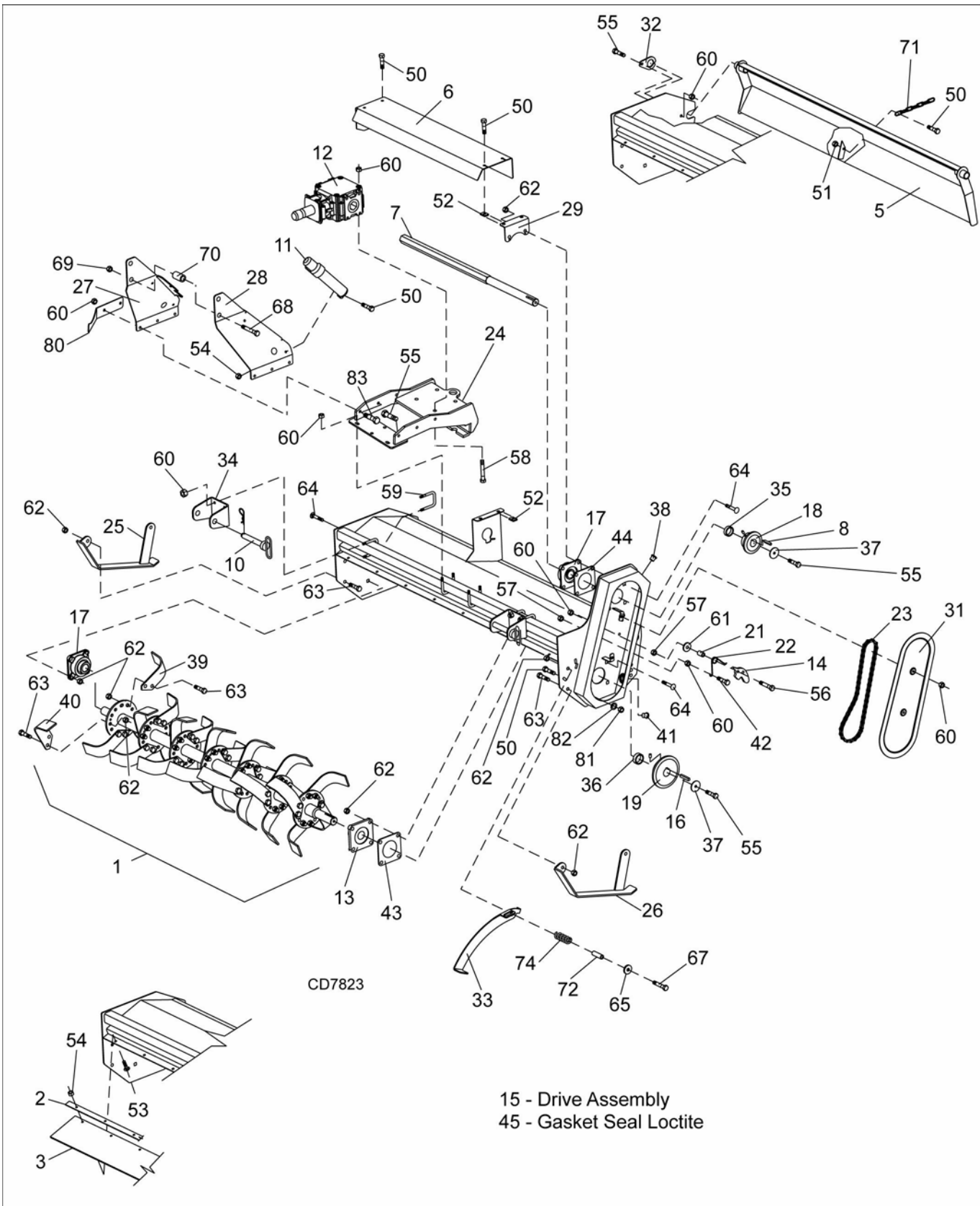

30 Parts

(Rev. 3/1/2012)

MAN0813 (3/17/2010)

TC68/TCR68 ROTARY TILLER ASSEMBLY

REF	PART NO	QTY	DESCRIPTION	REF	PART NO	QTY	DESCRIPTION
1	102676568	1	Rotor Shaft	42	976 *	1	3/8NC x 1-1/2 HHCS GR5
2	103183468	1	Clamp, Rubber Shield (TCR Models Only)	43	1031951	1	Gasket, 1-1/2 Bearing
3	103183668	1	Rubber Shield (TCR Models Only)	44	1031953	1	Gasket, 1-5/8 Bearing
5	1031983	1	Tailgate	45	1031940	1	Gasket Seal Loctite, 598 70ml
6	1031980	1	Top Shield	50	71851 *	4	5/16NC x 3/4 Flange HHCS
7	103192268	1	Hex Drive Shaft	51	14139 *	1	5/16NC Flange Lock Nut ZP
10	1023033	2	Hitch Pin	52	74047	4	5/16-18 U-Tapered Spring Nut
11	1026530	1	Manual Tube	53	51243 *	11	5/16NC x 1 Carriage Bolt GR5 ZP (Manual Tube and TCR Models Only)
12	1032606	1	Gearbox, 1.46:1	54	73163	11	5/16NC Flanged Whiz Nut YD (Manual Tube and TCR Models Only)
13	1031927	2	Kit, Bearing 1-1/2 & Sleeve	55	62153	9	3/8NC X 1 Hex Flange SRTD Screw
14	1026803	1	Chain Tensioner	56	300157 *	1	3/8NC x 2-1/4 HHCS GR5 ZP
15	-----	1	Drive Assembly Complete (Not Shown - See page 34 and 35.)	57	6698 *	2	3/8NC Lock Nut ZP
16	1031228	2	Key 3/8 x 3/8 x 1-1/2	58	57816 *	4	1/2 SAE Flat Washer, Hardened
17	1031928	1	Kit, Bearing 1-5/8 & Sleeve	59	35646	6	3/8 U-Bolt
18	1026806	1	Sprocket 80B 11T	60	70069	21	3/8NC Flanged Whiz Nut
19	1026807	1	Sprocket 80B 17T	61	2210 *	1	7/16 Flat Washer
21	1031833	1	Sleeve, .75 x .44 x .81	62	1031226	81	1/2NC Flange Nut
22	1031841	1	Torsion Spring, LT Hand - TCR	63	1031925 *	72	1/2NC x 1-1/4 HHCS GR5 ZP
	1031828	1	Torsion Spring, RT Hand - TC	64	29893 *	10	1/2NC x 1-1/2 CRG Bolt GR5 ZP
23	1031829	1	Chain #80 x 46 Continuous	65	854 *	1	1/2 Flat Washer
24	1033033	1	Gearbox Mount	66	12735	2	1/2NC x 1-3/4 CRG GR5 ZP
25	1026800	1	Skid Shoe, Right Hand	67	14069 *	1	1/2NC x 3-1/4 HHCS
26	1026801	1	Skid Shoe, Left Hand	68	15007 *	1	3/4NC x 3-1/2 HHCS GR5 ZP
27	1026784	1	Mast Plate, Right Hand	69	2371 *	1	3/4NC Lock Nut ZP
28	1026785	1	Mast Plate, Left Hand	70	1002018	1	Sleeve, .81 x 1.25 x 2.12
29	1026791	1	Shield Mount	71	1031958	1	2/0 STR Link Chain - 15 Link
31	1031240	1	Chain Case Cover	72	19509	1	Sleeve, .51 x .75 x 2.34
32	1026802	1	Tailgate Lock Plate	74	67195	1	Compression Spring
33	1026818	1	Parking Stand	75	1031974	--	TC Model Decal Set
34	1026780	2	Hitch Clevis	76	1031975	--	TCR Model Decal Set
35	1031948	1	Spacer 1.53 x 1.87 x .62	77	1031976	--	Tiller Safety Decal Set
36	1031946	1	Spacer 1.65 x 2.00 x .75	78	1033749	--	00 Grease, 1 quart (Not Shown)
37	1031950	2	Washer, 10ga	79	14350	4	3/8 NC Flange Lock Nut
38	11975	1	1/2 NPT Vent Plug	80	1033955	1	Driveline Holder TC
39	1031934	16	Speed Blade, Right Hand	81	14139 *	1	Nut, Lock 5/16NC Flange
40	1031935	16	Speed Blade, Left Hand	82	1033959	1	Washer, 5/16 Neoprene
41	4510	1	1/2 Pipe Plug	83	1033958	2	3/8NC x 1-1/4 Hex Flange SRTD Screw

HHCS Hex Head Cap Screw
* Obtain Locally

TC74/TCR74 ROTARY TILLER ASSEMBLY

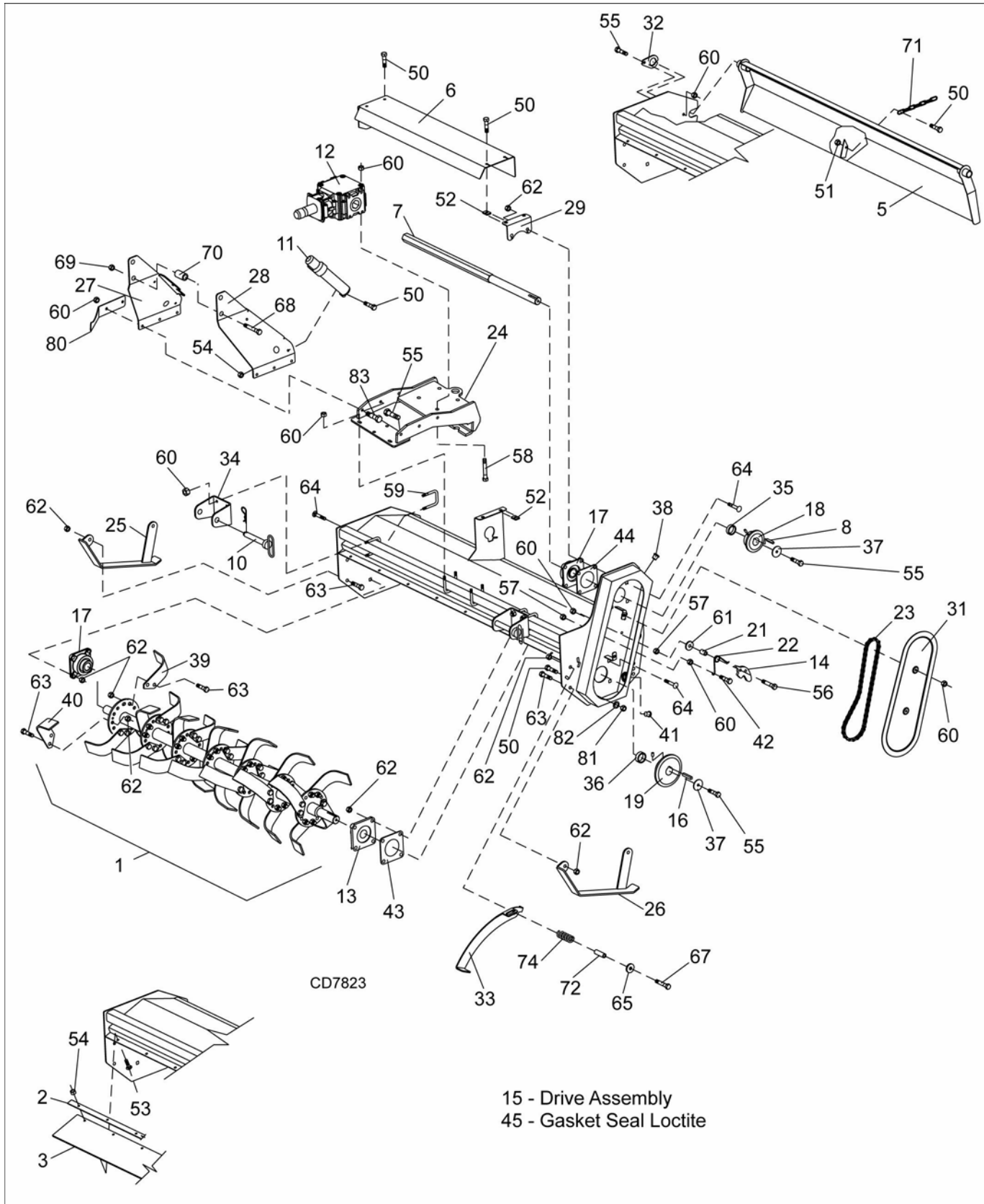

32 Parts

(Rev. 3/1/2012)

MAN0813 (3/17/2010)

TC74/TCR74 ROTARY TILLER ASSEMBLY

REF	PART NO	QTY	DESCRIPTION	REF	PART NO	QTY	DESCRIPTION
1	102676574	1	Rotor Shaft	42	976 *	1	3/8NC x 1-1/2 HHCS GR5
2	103183474	1	Clamp, Rubber Shield (TCR Models Only)	43	1031951	1	Gasket, 1-1/2 Bearing
3	103183674	1	Rubber Shield (TCR Models Only)	44	1031953	1	Gasket, 1-5/8 Bearing
5	1031984	1	Tailgate	45	1031940	1	Gasket Seal Loctite, 590 70ml
6	1031981	1	Top Shield	50	71851 *	4	5/16NC x 3/4 Flange HHCS
7	103192274	1	Hex Drive Shaft	51	14139 *	1	5/16NC Flange Lock Nut ZP
10	1023033	2	Hitch Pin	52	74047	4	5/16-18 U-Tapered Spring Nut
11	1026530	1	Manual Tube	53	51243 *	12	5/16NC x 1 Carriage Bolt GR5 ZP (Manual Tube and TCR Models Only)
12	1032606	1	Gearbox, 1.46:1	54	73163	12	5/16NC Flanged Whiz Nut YD (Manual Tube and TCR Models Only)
13	1026790	2	Bearing, 1.50 Dia, 4-Bolt Flange -or-	55	62153	9	3/8NC X 1 Hex Flange SRTD Screw
13	1032608	2	1.50 Dia, Bearing Insert with collar	56	300157 *	1	3/8NC x 2-1/4 HHCS GR5 ZP
14	1026803	1	Chain Tensioner	57	6698 *	2	3/8NC Lock Nut ZP
15	-----	1	Drive Assembly Complete (Not Shown - See page 34 and 35.)	58	57816 *	4	1/2 SAE Flat Washer, Hardened
16	1031228	2	Key 3/8 x 3/8 x 1-1/2	59	35646	6	3/8 U-Bolt
17	1031907	1	Bearing, 1.62 Dia, 4-Bolt Flange -or-	60	70069	21	3/8NC Flanged Whiz Nut
17	1032609	1	1.62 Dia, Bearing Insert with collar	61	2210 *	1	7/16 Flat Washer
18	1026806	1	Sprocket 80B 11T	62	1031226	89	1/2NC Flange Nut
19	1026807	1	Sprocket 80B 17T	63	1031925 *	80	1/2NC x 1-1/4 HHCS GR5 ZP
21	1031833	1	Sleeve, .75 x .44 x .81	64	29893 *	10	1/2NC x 1-1/2 CRG Bolt GR5 ZP
22	1031841	1	Torsion Spring, LT Hand - TCR	65	854 *	1	1/2 Flat Washer
	1031828	1	Torsion Spring, RT Hand - TC	66	12735	2	1/2NC x 1-3/4 CRG GR5 ZP
23	1031829	1	Chain #80 x 46 Continuous	67	14069 *	1	1/2NC x 3-1/4 HHCS
24	1033033	1	Gearbox Mount	68	15007 *	1	3/4NC x 3-1/2 HHCS GR5 ZP
25	1026800	1	Skid Shoe, Right Hand	69	2371 *	1	3/4NC Lock Nut ZP
26	1026801	1	Skid Shoe, Left Hand	70	1002018	1	Sleeve, .81 x 1.25 x 2.12
27	1026784	1	Mast Plate, Right Hand	71	1031958	1	2/0 STR Link Chain - 15 Link
28	1026785	1	Mast Plate, Left Hand	72	19509	1	Sleeve, .51 x .75 x 2.34
29	1026791	1	Shield Mount	74	67195	1	Compression Spring
31	1031240	1	Chain Case Cover	75	1031974	--	TC Model Decal Set
32	1026802	1	Tailgate Lock Plate	76	1031975	--	TCR Model Decal Set
33	1026818	1	Parking Stand	77	1031976	--	Tiller Safety Decal Set
34	1026780	2	Hitch Clevis	78	1033749	--	00 Grease, 1 quart (Not Shown)
35	1031948	1	Spacer 1.53 x 1.87 x .62	79	14350	4	3/8 NC Flange Lock Nut
36	1031946	1	Spacer 1.65 x 2.00 x .75	80	1033955	1	Driveline Holder TC
37	1031950	2	Washer, 10ga	81	14139 *	1	Nut, Lock 5/16NC Flange
38	11975	1	1/2 NPT Vent Plug	82	1033959	1	Washer, 5/16 Neoprene
39	1031934	18	Speed Blade, Right Hand	83	1033958	2	3/8NC x 1-1/4 Hex Flange SRTD Screw
40	1031935	18	Speed Blade, Left Hand				
41	4510	1	1/2 Pipe Plug				

HHCS Hex Head Cap Screw

* Obtain Locally

1031825 - COMER SLIP CLUTCH DRIVE ASSEMBLY

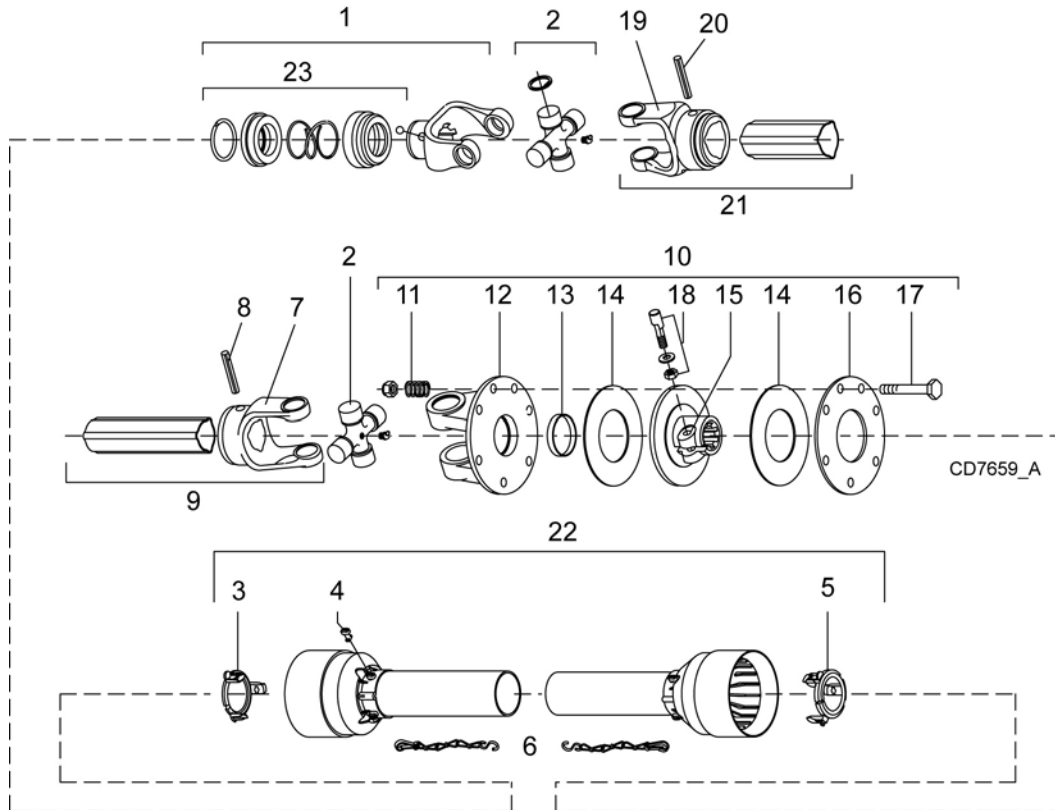

REF	PART	QTY	DESCRIPTION
A	1031825	1	Complete 540 driveline and clutch assembly
1	1001300	1	Complete collar yoke C12 1-3/8
2	38478	2	Cross & bearing kit
3	1019442	1	Collar, outer tube
4	30922	6	Shield retainer
5	1019444	1	Collar, inner tube
6	30197	2	Shield tether chains
7	1001306	1	Yoke, inner tube
8	1001305	1	Flexible pin
9	30928	1	Inner profile tube & yoke
10	1032431	1	Friction clutch assembly
11	1001311	8	Spring
12	1001312	1	Flanged Yoke
13	1001313	1	Bushing
14	1001314	2	Lining ring
15	1032432	1	Clutch support
16	1001317	1	Pressure plate
17	1001318	8	Bolt and nut M10 x 80
18	1001274	1	Tapered Pin Set
19	1001301	1	Yoke, outer tube
20	1001302	1	Flexible pin
21	30926	1	Outer profile tube & yoke
22	1021552	1	Complete shield kit T40
23	1001340	1	Lock collar repair kit

34 Parts

(Rev. 10/4/2011)
MAN0813 (3/17/2010)

1031826 - COMER SHEAR BOLT DRIVE ASSEMBLY (OPTIONAL)

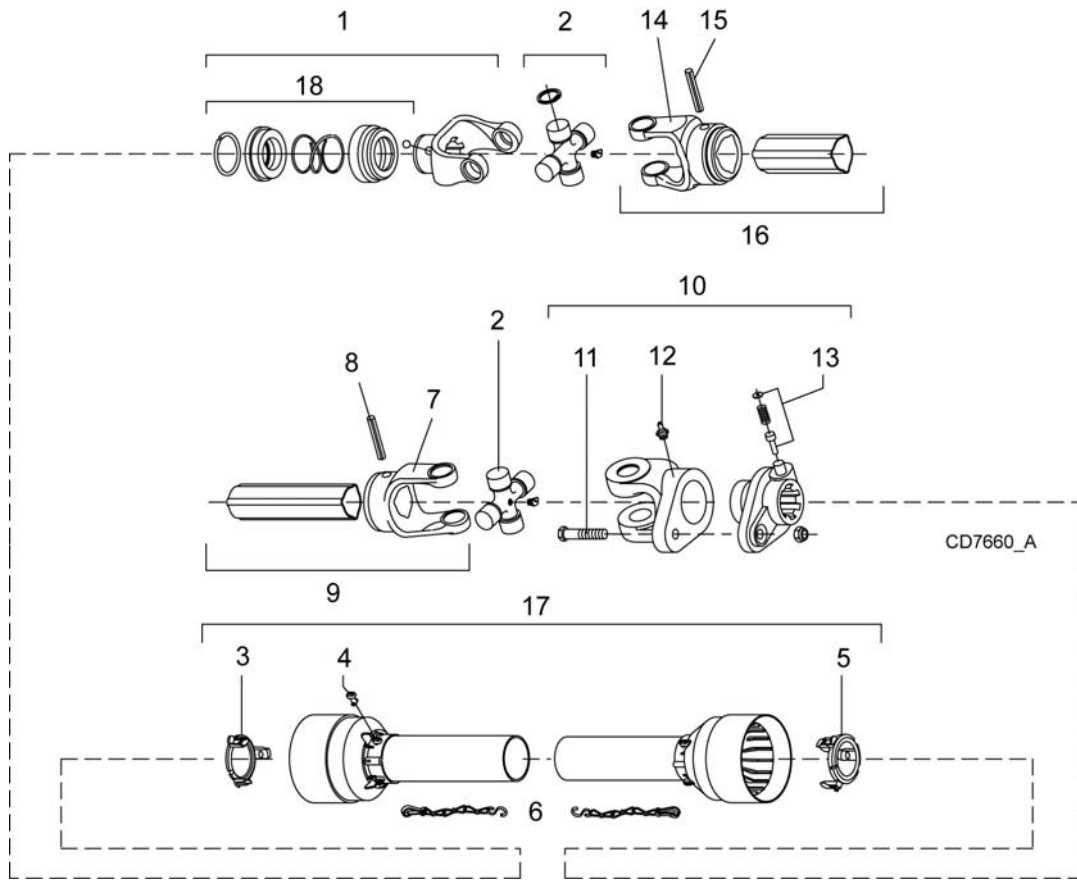

REF	PART	QTY	DESCRIPTION
A	1031826	1	Complete 540 driveline and shear bolt assembly
1	1001300	1	Complete collar yoke C12 1-3/8
2	38478	2	Cross & bearing kit
3	1019442	1	Collar, outer tube
4	30922	6	Shield retainer
5	1019444	1	Collar, inner tube
6	30917	2	Shield tether chains
7	1001306	1	Yoke, inner tube
8	1001305	1	Flexible pin
9	30928	1	Inner profile tube & yoke
10	1032435	1	Shear yoke assembly
11	1032436	1	Bolt and Nut M8 x 50 cl 8.8
12	1032430	1	Grease fitting
13	30913	1	1-3/8 Push pin set
14	1001301	1	Yoke, outer tube
15	1001302	1	Flexible pin
16	30926	1	Outer profile tube & yoke
17	1021552	1	Complete shield kit
18	1001340	1	Lock collar repair kit

1032606 - GEARBOX ASSEMBLY

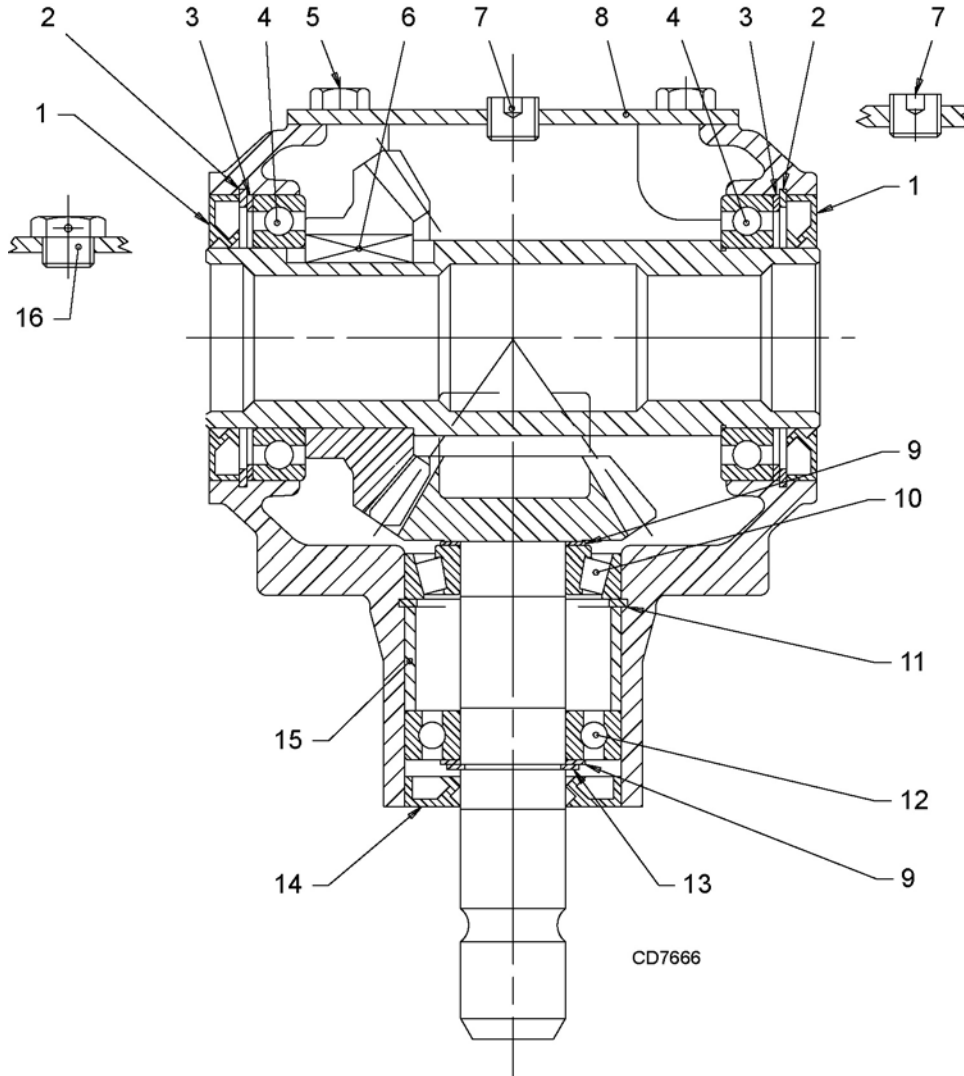

REF	PART	QTY	DESCRIPTION
A	1032606	1	Cast Iron tee gearbox
1	1032437	2	Seal, metric 60 x 95 x 10
2	1032408	2	Snap ring, metric 95 x 98.5 x 3
3	1032409	2	Shim kit, metric 85.3 x 94.7
4	1032445	2	Ball Bearing 6012
5	1032446	4	Cap Screw, M10-1.50 x 20mm cl 8.8
6	1008155	1	Parallel Key, metric 14 x 9 x 35 Hardened
7	27326	2	3/8 NPT Hex Plug
8	1032447	1	Gearbox cover
9	1007866	2	Shim kit, metric 35.3 x 48
10	1032448	1	Tapered roller bearing 30207
11	57466	1	Snap ring, metric 72 x 75 x 2.5
12	20890	1	Ball Bearing 6207
13	1007859	1	Snap ring, metric 35 x 33 x 1.5
14	1032401	1	Seal, metric 35 x 72 x 10
15	1032604	1	Spacer, metric 64.3 x 71.8 x 34.1
16	1032605	1	3/8 NPT breather plug

36 Parts

(Rev 09/28/2010)
MAN0813 (3/17/2010)

BOLT TORQUE CHART

Always tighten hardware to these values unless a different torque value or tightening procedure is listed for a specific application.

Fasteners must always be replaced with the same grade as specified in the manual parts list.

Always use the proper tool for tightening hardware: SAE for SAE hardware and Metric for metric hardware.

Make sure fastener threads are clean and you start thread engagement properly.

All torque values are given to specifications used on hardware defined by SAE J1701 MAR 99 & J1701M JUL 96.

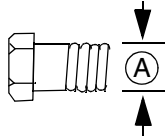

SAE SERIES TORQUE CHART



SAE Grade 2
(No Dashes)

SAE Bolt Head Identification



SAE Grade 5
(3 Radial Dashes)



SAE Grade 8
(6 Radial Dashes)

Ⓐ Diameter (Inches)	Wrench Size	MARKING ON HEAD					
		SAE 2		SAE 5		SAE 8	
		lbs-ft	N-m	lbs-ft	N-m	lbs-ft	N-m
1/4"	7/16"	6	8	10	13	14	18
5/16"	1/2"	12	17	19	26	27	37
3/8"	9/16"	23	31	35	47	49	67
7/16"	5/8"	36	48	55	75	78	106
1/2"	3/4"	55	75	85	115	120	163
9/16"	13/16"	78	106	121	164	171	232
5/8"	15/16"	110	149	170	230	240	325
3/4"	1-1/8"	192	261	297	403	420	569
7/8"	1-5/16"	306	416	474	642	669	907
1"	1-1/2"	467	634	722	979	1020	1383

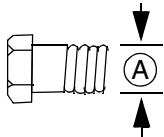

METRIC SERIES TORQUE CHART



8.8
Metric
Grade 8.8

Metric Bolt Head Identification



10.9
Metric
Grade 10.9

Ⓐ Diameter & Thread Pitch (Millimeters)	Wrench Size	Coarse Thread				Fine Thread				Ⓐ Diameter & Thread Pitch (Millimeters)
		Marking on Head								
		Metric 8.8		Metric 10.9		Metric 8.8		Metric 10.9		
		N-m	lbs-ft	N-m	lbs-ft	N-m	lbs-ft	N-m	lbs-ft	
6 x 1.0	10 mm	8	6	11	8	8	6	11	8	6 x 1.0
8 x 1.25	13 mm	20	15	27	20	21	16	29	22	8 x 1.0
10 x 1.5	16 mm	39	29	54	40	41	30	57	42	10 x 1.25
12 x 1.75	18 mm	68	50	94	70	75	55	103	76	12 x 1.25
14 x 2.0	21 mm	109	80	151	111	118	87	163	120	14 x 1.5
16 x 2.0	24 mm	169	125	234	173	181	133	250	184	16 x 1.5
18 x 2.5	27 mm	234	172	323	239	263	194	363	268	18 x 1.5
20 x 2.5	30 mm	330	244	457	337	367	270	507	374	20 x 1.5
22 x 2.5	34 mm	451	332	623	460	495	365	684	505	22 x 1.5
24 x 3.0	36 mm	571	421	790	583	623	459	861	635	24 x 2.0
30 x 3.0	46 mm	1175	867	1626	1199	1258	928	1740	1283	30 x 2.0

Typical Washer Installations

8/9/00

BOLT SIZE CHART

NOTE: Chart shows bolt thread sizes and corresponding head (wrench) sizes for standard SAE and metric bolts.

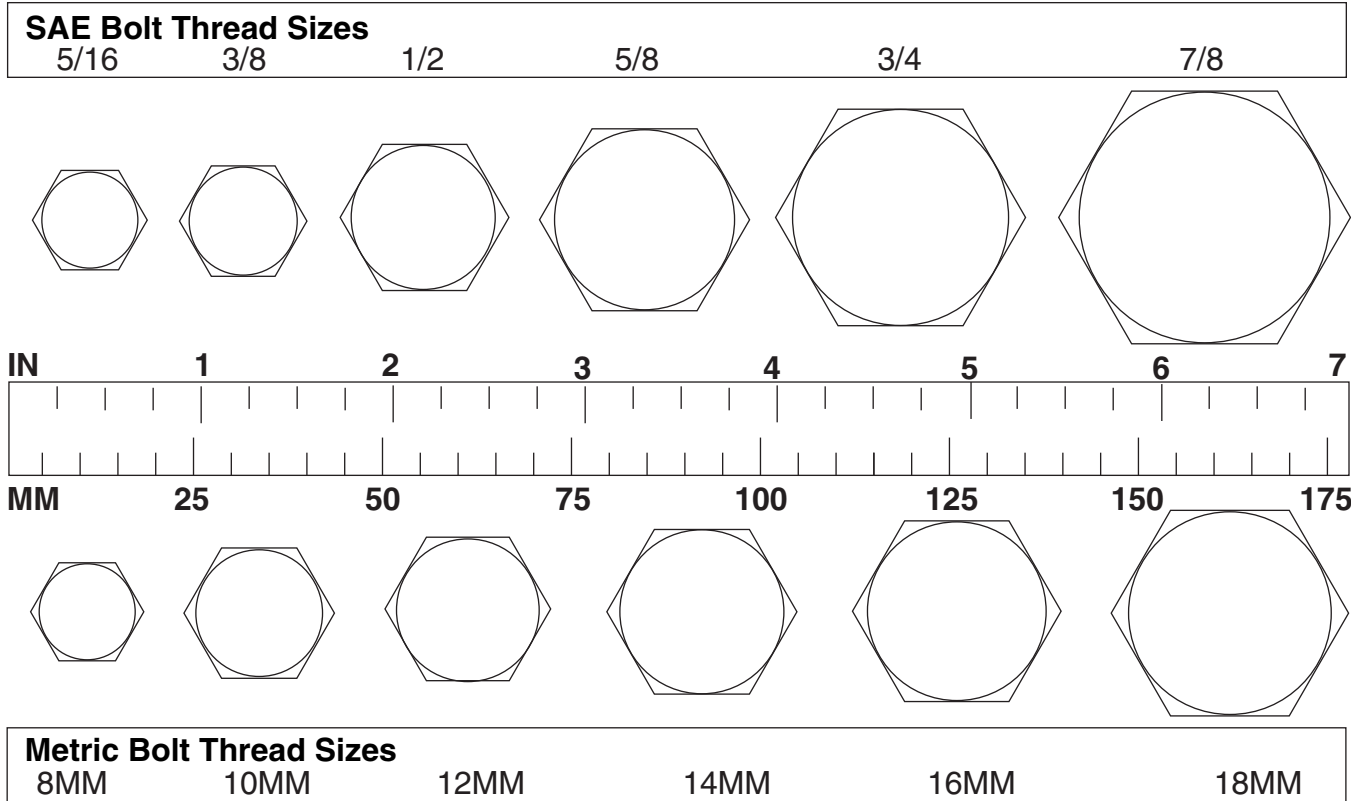

ABBREVIATIONS

AG Agriculture
 ASABE American Society of Agricultural & Biological Engineers (formerly ASAE)
 ASAE..... American Society of Agricultural Engineers
 ATF.....Automatic Transmission Fluid
 BSPP..... British Standard Pipe Parallel
 BSPTM..... British Standard Pipe Tapered Male
 CV Constant Velocity
 CCW..... Counter-Clockwise
 CW Clockwise
 F Female
 FT..... Full Thread
 GA Gauge
 GR (5, etc.)..... Grade (5, etc.)
 HHCS Hex Head Cap Screw
 HT Heat-Treated
 JIC..... Joint Industry Council 37° Degree Flare
 LH..... Left Hand
 LT Left
 m Meter
 mm Millimeter
 M Male

MPa Mega Pascal
 N Newton
 NC..... National Coarse
 NF National Fine
 NPSM National Pipe Straight Mechanical
 NPT.....National Pipe Tapered
 NPT SWF..... National Pipe Tapered Swivel Female
 ORBM O-Ring Boss - Male
 P Pitch
 PBY.....Power-Beyond
 psi Pounds per Square Inch
 PTO.....Power Take Off
 QD Quick Disconnect
 RH..... Right Hand
 ROPS..... Roll-Over Protective Structure
 RPM.....Revolutions Per Minute
 RT Right
 SAE..... Society of Automotive Engineers
 UNC Unified Coarse
 UNF Unified Fine
 UNS Unified Special



WARRANTY

All Models Except Mow'n Machine™ Zero-Turn Mowers

Please Enter Information Below and Save for Future Reference.

Date Purchased: _____ From (Dealer): _____

Model Number: _____ Serial Number: _____

Woods Equipment Company ("WOODS") warrants this product to be free from defect in material and workmanship. Except as otherwise set forth below, the duration of this Warranty shall be for TWELVE (12) MONTHS COMMENCING ON THE DATE OF DELIVERY OF THE PRODUCT TO THE ORIGINAL PURCHASER.

All current model loaders and backhoes are warranted for two (2) years from the date of delivery to the original purchaser.

The warranty periods for specific parts or conditions are listed below:

Part or Condition Warranted	Model Number	Duration (from date of delivery to the original purchaser)
	All units invoiced after 4/30/2012	
Gearbox components	BW1260, BW1620, BW1800, BW1260X, BW1800X, BW2400 BW240HD, BW180HD, BW180HB, BW126HB, BW126XHD, BW180XHD BB48X, BB60X, BB72X, BB84X, BB600X, BB720X, BB840X, BB6000X, BB7200X, BB8400X, DS1260, DSO1260, DS1440, TS1680, BW126-3, BW180-3, BW240, BW126X, BW180X	6 years
	PHD25, PHD35, PHD65, PHD95, DS96, DS120, RCC42, RD990X, PRD6000, PRD7200, PRD8400, S15CD, S20CD, S22CD, S25CD, S27CD, S30CD BW15LH, TC/R74, TC/R68, TC/R60, TBW144, TBW180, TBW204	
	RDC54, RD60, RD72, TBW150C, TS/R60, TS/R52, TS/R44, HC48, HC54, HC60, HC72	3 years (1 year if used in rental or commercial applications)
Blade spindles	RD990X, PRD6000, PRD7200, PRD8400, TBW144, TBW180, TBW204	3 years
Rust-through	BB600, BB720, BB840, BB6000, BB7200, BB8400, BW126-3, BW126HB, BW180-3, BW180HB, BW180HD, BW1260, BW1800, BW240, BW240HD, DS1260, DSO1260, DS1440, TS1680	10 years

Under no circumstances will this Warranty apply in the event that the product, in the good faith opinion of WOODS, has been subjected to improper operation, improper maintenance, misuse, or an accident. This Warranty does not apply in the event that the product has been materially modified or repaired by someone other than WOODS, a WOODS authorized dealer or distributor, and/or a WOODS authorized service center. This Warranty does not cover normal wear or tear, or normal maintenance items. This Warranty also does not cover repairs made with parts other than those obtainable through WOODS.

This Warranty is extended solely to the original purchaser of the product. Should the original purchaser sell or otherwise transfer this product to a third party, this Warranty does not transfer to the third party purchaser in any way. There are no third party beneficiaries of this Warranty.

WOODS makes no warranty, express or implied, with respect to engines, batteries, tires or other parts or accessories not manufactured by WOODS. Warranties for these items, if any, are provided separately by their respective manufacturers.

WOODS' obligation under this Warranty is limited to, at WOODS' option, the repair or replacement, free of charge, of the product if WOODS, in its sole discretion, deems it to be defective or in noncompliance with this Warranty. **The product must be returned to WOODS with proof of purchase within thirty (30) days after such defect or noncompliance is discovered or should have been discovered, routed through the dealer and distributor from whom the purchase was made, transportation charges prepaid.** WOODS shall complete such repair or replacement within a reasonable time after WOODS receives the product. **THERE ARE NO OTHER REMEDIES UNDER THIS WARRANTY. THE REMEDY OF REPAIR OR REPLACEMENT IS THE SOLE AND EXCLUSIVE REMEDY UNDER THIS WARRANTY.**

THERE ARE NO WARRANTIES WHICH EXTEND BEYOND THE DESCRIPTION ON THE FACE OF THIS WARRANTY. WOODS MAKES NO OTHER WARRANTY, EXPRESS OR IMPLIED, AND WOODS SPECIFICALLY DISCLAIMS ANY IMPLIED WARRANTY OF MERCHANTABILITY AND/OR ANY IMPLIED WARRANTY OF FITNESS FOR A PARTICULAR PURPOSE.

WOODS shall not be liable for any incidental or consequential losses, damages or expenses, arising directly or indirectly from the product, whether such claim is based upon breach of contract, breach of warranty, negligence, strict liability in tort or any other legal theory. Without limiting the generality of the foregoing, Woods specifically disclaims any damages relating to (i) lost profits, business, revenues or goodwill; (ii) loss of crops; (iii) loss because of delay in harvesting; (iv) any expense or loss incurred for labor, supplies, substitute machinery or rental; or (v) any other type of damage to property or economic loss.

This Warranty is subject to any existing conditions of supply which may directly affect WOODS' ability to obtain materials or manufacture replacement parts.

No agent, representative, dealer, distributor, serviceperson, salesperson, or employee of any company, including without limitation, WOODS, its authorized dealers, distributors, and service centers, is authorized to alter, modify, or enlarge this Warranty. Answers to any questions regarding warranty service and locations may be obtained by contacting:

Woods Equipment Company

2606 South Illinois Route 2
Post Office Box 1000
Oregon, Illinois 61061 USA

800-319-6637 tel
800-399-6637 fax
www.WoodsEquipment.com



ALITEC™
BMP®
CENTRAL FABRICATORS®
GANNON®
GILL®
WAIN-ROY®
WOODS®



WARRANTY

(Replacement Parts For All Models Except Mow'n Machine™
Zero-Turn Mowers)

Woods Equipment Company ("WOODS") warrants this product to be free from defect in material and workmanship for a period of ninety (90) days from the date of delivery of the product to the original purchaser with the exception of V-belts, which will be free of defect in material and workmanship for a period of 12 months.

Under no circumstances will this Warranty apply in the event that the product, in the good faith opinion of WOODS, has been subjected to improper operation, improper maintenance, misuse, or an accident. This Warranty does not cover normal wear or tear, or normal maintenance items.

This Warranty is extended solely to the original purchaser of the product. Should the original purchaser sell or otherwise transfer this product to a third party, this Warranty does not transfer to the third party purchaser in any way. There are no third party beneficiaries of this Warranty.

WOODS' obligation under this Warranty is limited to, at WOODS' option, the repair or replacement, free of charge, of the product if WOODS, in its sole discretion, deems it to be defective or in noncompliance with this Warranty. **The product must be returned to WOODS with proof of purchase within thirty (30) days after such defect or noncompliance is discovered or should have been discovered, routed through the dealer and distributor from whom the purchase was made, transportation charges prepaid.** WOODS shall complete such repair or replacement within a reasonable time after WOODS receives the product. THERE ARE NO OTHER REMEDIES UNDER THIS WARRANTY. THE REMEDY OF REPAIR OR REPLACEMENT IS THE SOLE AND EXCLUSIVE REMEDY UNDER THIS WARRANTY.

THERE ARE NO WARRANTIES WHICH EXTEND BEYOND THE DESCRIPTION ON THE FACE OF THIS WARRANTY. WOODS MAKES NO OTHER WARRANTY, EXPRESS OR IMPLIED, AND WOODS SPECIFICALLY DISCLAIMS ANY IMPLIED WARRANTY OF MERCHANTABILITY AND/OR ANY IMPLIED WARRANTY OF FITNESS FOR A PARTICULAR PURPOSE.

WOODS shall not be liable for any incidental or consequential losses, damages or expenses, arising directly or indirectly from the product, whether such claim is based upon breach of contract, breach of warranty, negligence, strict liability in tort or any other legal theory. Without limiting the generality of the foregoing, Woods specifically disclaims any damages relating to (i) lost profits, business, revenues or goodwill; (ii) loss of crops; (iii) loss because of delay in harvesting; (iv) any expense or loss incurred for labor, supplies, substitute machinery or rental; or (v) any other type of damage to property or economic loss.

This Warranty is subject to any existing conditions of supply which may directly affect WOODS' ability to obtain materials or manufacture replacement parts.

No agent, representative, dealer, distributor, service person, salesperson, or employee of any company, including without limitation, WOODS, its authorized dealers, distributors, and service centers, is authorized to alter, modify, or enlarge this Warranty.

Answers to any questions regarding warranty service and locations may be obtained by contacting:

ALITEC™
BMP®
CENTRAL FABRICATORS®
GANNON®
GILL®
WAIN-ROY®
WOODS®

WOODS®

**Woods Equipment
Company**

2606 South Illinois Route 2
Post Office Box 1000
Oregon IL 61061

800-319-6637 tel
800-399-6637 fax
www.WoodsEquipment.com

Free Manuals Download Website

<http://myh66.com>

<http://usermanuals.us>

<http://www.somanuals.com>

<http://www.4manuals.cc>

<http://www.manual-lib.com>

<http://www.404manual.com>

<http://www.luxmanual.com>

<http://aubethermostatmanual.com>

Golf course search by state

<http://golfingnear.com>

Email search by domain

<http://emailbydomain.com>

Auto manuals search

<http://auto.somanuals.com>

TV manuals search

<http://tv.somanuals.com>