

WOODS MOW'N MACHINE VACUUM

**D5221T, D6121T
on F-Series
Power Units**

MAN0116

Rev. 4/15/2004

WOODS®
Tested. Proven. Unbeatable.

OPERATOR'S MANUAL

TO THE DEALER:

Assembly and proper installation of this product is the responsibility of the Woods® dealer. Read manual instructions and safety rules. Make sure all items on the Dealer's Pre-Delivery and Delivery Check Lists in the Operator's Manual are completed before releasing equipment to the owner.

The dealer must complete the Product Registration included in this manual. Both dealer and customer must sign the registration which certifies that all Dealer Check List items have been completed. The dealer is to return the prepaid postage portion to Woods, give one copy to the customer, and retain one copy. **Failure to complete and return this card does not diminish customer's warranty rights.**

TO THE OWNER:

Read this manual before operating your Woods equipment. The information presented will prepare you to do a better and safer job. Keep this manual handy for ready reference. Require all operators to read this manual carefully and become acquainted with all adjustment and operating procedures before attempting to operate. Replacement manuals can be obtained from your dealer. To locate your nearest dealer, check the Dealer Locator at www.woodsonline.com, or in the United States and Canada call 1-800-319-6637.

The equipment you have purchased has been carefully engineered and manufactured to provide dependable and satisfactory use. Like all mechanical products, it will require cleaning and upkeep. Lubricate the unit as specified. Observe all safety information in this manual and safety decals on the equipment.

For service, your authorized Woods dealer has trained mechanics, genuine Woods service parts, and the necessary tools and equipment to handle all your needs.

Use only genuine Woods service parts. Substitute parts will void the warranty and may not meet standards required for safe and satisfactory operation. Record the model number and serial number of your equipment in the spaces provided:

Model: _____ **Date of Purchase:** _____

Serial Number: (see Safety Decal section for location) _____

Provide this information to your dealer to obtain correct repair parts.

Throughout this manual, the term **IMPORTANT** is used to indicate that failure to observe can cause damage to equipment. The terms **CAUTION**, **WARNING**, and **DANGER** are used in conjunction with the Safety-Alert Symbol (a triangle with an exclamation mark) to indicate the degree of hazard for items of personal safety.



This Safety-Alert Symbol indicates a hazard and means ATTENTION! BECOME ALERT! YOUR SAFETY IS INVOLVED!



DANGER

Indicates an imminently hazardous situation that, if not avoided, will result in death or serious injury.



WARNING

Indicates a potentially hazardous situation that, if not avoided, could result in death or serious injury, and includes hazards that are exposed when guards are removed.



CAUTION

Indicates a potentially hazardous situation that, if not avoided, may result in minor or moderate injury.

IMPORTANT

Indicates that failure to observe can cause damage to equipment.

NOTE

Indicates helpful information.

WOODS®

ALITEC®
ALLOWAY®
BMP®
CENTRAL FABRICATORS®
GANNON®
GILL®
WAIN-ROY®
WOODS®

TABLE OF CONTENTS

INTRODUCTION	II
GENERAL INFORMATION	1
SAFETY RULES	2
SAFETY DECALS	4
INSTALLATION	5
CHECK LISTS	9
SERVICE	10
PARTS LISTS	13
BOLT TORQUE CHART	14
BOLT SIZE CHART & ABBREVIATIONS	15
REPLACEMENT PARTS WARRANTY	16
PRODUCT WARRANTY	INSIDE BACK COVER

GENERAL INFORMATION

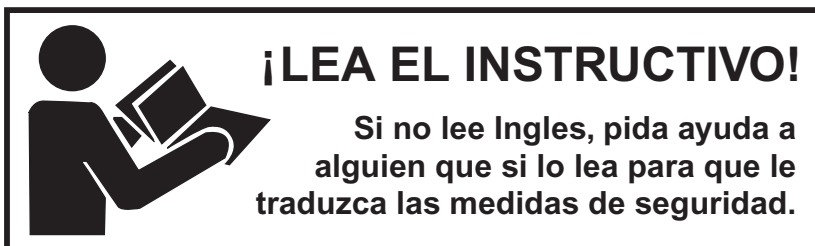

The purpose of this manual is to assist you in operating and maintaining your vacuum system. Read it carefully. It furnishes information and instructions that will help you achieve years of dependable performance. These instructions have been compiled from extensive field experience and engineering data. Some information may be general in nature due to unknown and varying operating conditions. However, through experience and these instructions, you should be able to develop procedures suitable to your particular situation.

The illustrations and data used in this manual were current at the time of printing but, due to possible inline production changes, your machine may vary slightly in detail. We reserve the right to redesign and change the machines as may be necessary without notification.

WARNING

■ **Some illustrations in this manual show the mower with safety shields removed to provide a better view. The mower should never be operated with any safety shielding removed.**

Throughout this manual, references are made to right and left direction. These are determined by standing behind the equipment facing the direction of forward travel.

SAFETY RULES



ATTENTION! BECOME ALERT! YOUR SAFETY IS INVOLVED!



Safety is a primary concern in the design and manufacture of our products. Unfortunately, our efforts to provide safe equipment can be wiped out by an operator's single careless act.

In addition to the design and configuration of equipment, hazard control and accident prevention are dependent upon the awareness, concern, judgement, and proper training of personnel involved in the operation, transport, maintenance, and storage of equipment.

It has been said, "The best safety device is an informed, careful operator." We ask you to be that kind of operator.

TRAINING

■ **Safety instructions are important! Read all attachment and power unit manuals; follow all safety rules and safety decal information. (Replacement manuals and safety decals are available from your dealer. To locate your nearest dealer, check the Dealer Locator at www.woodsonline.com, or in the United States and Canada call 1-800-319-6637.) Failure to follow instructions or safety rules can result in serious injury or death.**

■ **If you do not understand any part of this manual and need assistance, see your dealer.**

■ **Know your controls and how to stop engine and attachment quickly in an emergency.**

■ **Operators must be instructed in and be capable of the safe operation of the equipment, its attachments, and all controls. Do not allow anyone to operate this equipment without proper instructions.**

■ **Never allow children or untrained persons to operate equipment.**

■ **Data indicates that those operators age 60 years and above are involved in a large percentage of riding mower-related injuries. Those operators should evaluate their ability to operate the riding mower safely enough to protect themselves and others from injury.**

PREPARATION

■ **Check that all hardware is properly installed. Always tighten to torque chart specifications unless instructed otherwise in this manual.**

■ **Always wear relatively tight and belted clothing to avoid entanglement in moving parts. Wear**

sturdy, rough-soled work shoes and protective equipment for eyes, hair, hands, hearing, and head.

■ **Make sure attachment is properly secured, adjusted, and in good operating condition.**

■ **Remove accumulated debris from this equipment, power unit, and engine to avoid fire hazard.**

■ **Make sure all safety decals are installed. Replace if damaged. (See Safety Decals section for location.)**

■ **Make sure shields and guards are properly installed and in good condition. Replace if damaged.**

■ **Be sure either the discharge chute, mulching end cap, or complete vacuum attachment is installed and in good condition. Replace if damaged.**

■ **Inspect and clear area of stones, branches, or other hard objects that might be thrown, causing injury or damage.**

OPERATION

■ **Keep bystanders away from equipment.**

■ **Do not operate or transport equipment while under the influence of alcohol or drugs.**

■ **Operate only in daylight or good artificial light.**

■ **Keep hands, feet, hair, and clothing away from equipment while engine is running. Stay clear of all moving parts.**

■ **Never allow riders on power unit or attachment.**

■ **Watch for hidden hazards on the terrain during operation.**

■ **Before making any adjustments on attachment, stop engine and engage parking brake. Never adjust or work on attachment while the power unit or attachment is running.**

■ **Do not allow bystanders in the area when operating, attaching, removing, assembling, or servicing equipment.**

■ **Keep children out of the mowing area and under the watchful care of a responsible adult other than the operator.**

■ **Be alert and turn machine off if a child enters the mowing area.**

■ **Before attempting to unplug vacuum hoses, disengage PTO, stop power unit, and remove key.**

SAFETY RULES



ATTENTION! BECOME ALERT! YOUR SAFETY IS INVOLVED!



- Before performing any service or maintenance, lower attachment to ground, turn off power unit engine, remove key, and disconnect battery ground cable (negative -).

TRANSPORTATION

- Use extra care when loading or unloading the machine onto a trailer or truck.
- Never allow riders on power unit or attachment.
- Do not operate or transport on steep slopes.
- Do not operate or transport equipment while under the influence of alcohol or drugs.

MAINTENANCE

- Before attempting to unplug vacuum hoses, disengage PTO, stop power unit, and remove key.
- Before performing any service or maintenance, lower attachment to ground, turn off power unit engine, remove key, and disconnect battery ground cable (negative -).
- Do not modify or alter or permit anyone else to modify or alter the equipment or any of its components in any way.

- Always wear relatively tight and belted clothing to avoid entanglement in moving parts. Wear sturdy, rough-soled work shoes and protective equipment for eyes, hair, hands, hearing, and head.

- Make sure attachment is properly secured, adjusted, and in good operating condition.

- Keep all persons away from operator control area while performing adjustments, service, or maintenance.

- Tighten all bolts, nuts and screws to torque chart specifications. Check that all cotter pins are installed securely to ensure equipment is in a safe condition before putting unit into service.

- Make sure all safety decals are installed. Replace if damaged. (See Safety Decals section for location.)

- Make sure shields and guards are properly installed and in good condition. Replace if damaged.

STORAGE

- Keep children and bystanders away from storage area.





SAFETY & INSTRUCTIONAL DECALS

ATTENTION! BECOME ALERT! YOUR SAFETY IS INVOLVED!



Replace Immediately If Damaged!

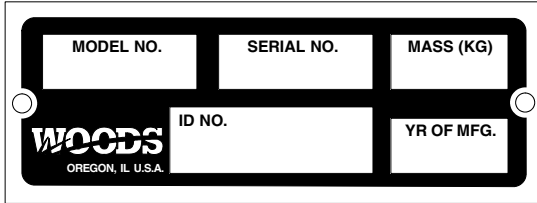

(Located on back side of blower housing)

2 - SERIAL NUMBER PLATE



1 - PN 72672



3 - PN 18869

BE CAREFUL!

Use a clean, damp cloth to clean safety decals.

Avoid spraying too close to decals when using a pressure washer; high-pressure water can enter through very small scratches or under edges of decals causing them to peel or come off.

Replacement safety decals can be ordered free from your Woods dealer. To locate your nearest dealer, check the Dealer Locator at www.woodsonline.com, or in the United States and Canada call 1-800-319-6637.

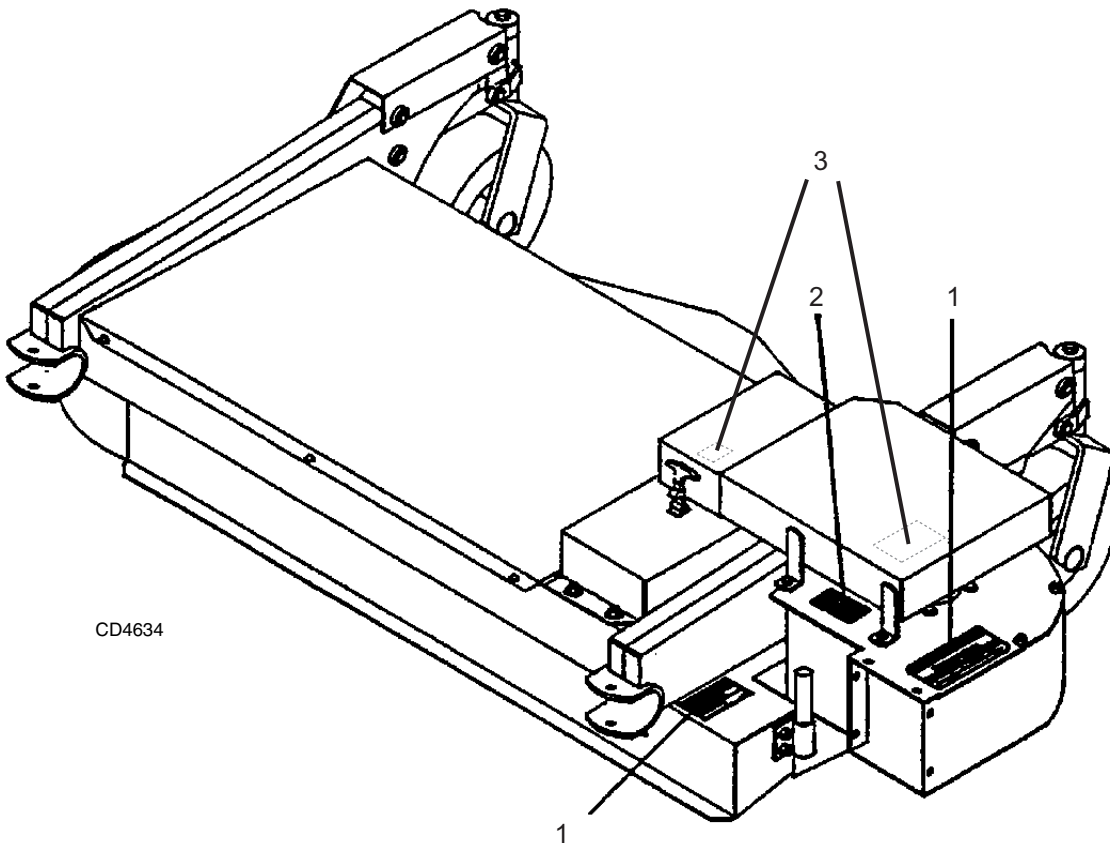

CD4634

VACUUM INSTALLATION

Remove Discharge Chute

1. Remove mower deck discharge chute by removing the two 1/4 NC hex nuts (2) and lifting the chute (1) away from the deck.
2. Place the discharge chute on the chute adapter (3) and secure with the two 1/4 NC hex nuts.

NOTE: The discharge chute must be installed whenever the vacuum housing assembly is removed.

Install discharge chute and adapter to deck using pivot mount, clevis shaft bracket, and hitch pin as described in 'Attach Discharge Chute' on page 6.

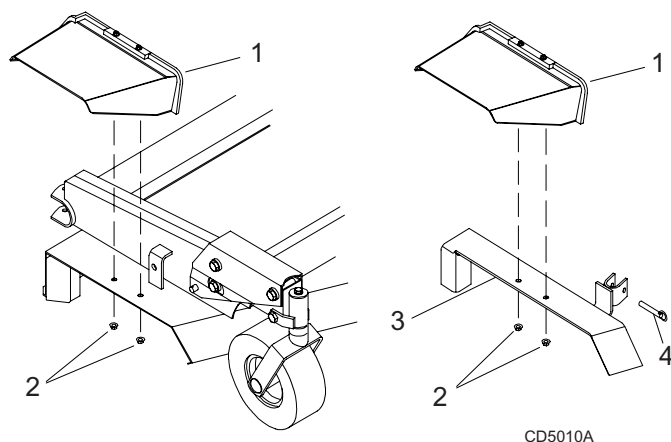

Figure 1. Discharge Removal

Attach Hose Adapter

1. Attach hose adapter (4) to vacuum housing (1) using six 1/4 x 1/2" truss head bolts (A). To prevent grass buildup inside the adapter, install bolts with nuts (B) on the outside as shown in Figure 2.

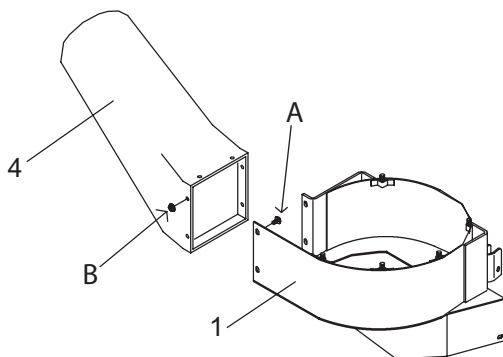

Figure 2. Hose Adapter Installation

Install Vacuum Housing

1. Install pivot mount bracket (3) using two 5/16 x 3/4 cap screws and whiz nuts as shown in Figure 3.
2. Install clevis shaft bracket (4) using two 5/16 x 3/4 cap screws and whiz nuts as shown in Figure 3.

NOTE: For easier adjustment, install the cap screws and nuts with the nuts on the outside of the deck.

3. Insert the pivot shaft (2) of vacuum housing assembly (1) into sleeve of pivot mount (3).
4. Pivot vacuum housing assembly in place so that the clevis on vacuum housing assembly slip around clevis shaft (4).
5. Install 3/8 x 2" hitch pin to lock the housing into place.

NOTE: If necessary, adjust the position of the clevis shaft bracket to allow for easy installation of hitch pin.

6. Tighten hardware.

Remove Vacuum Housing

1. Remove hitch pin
2. Pivot vacuum housing assembly from clevis shaft bracket (4).
3. Lift vacuum housing assembly from pivot mount (3).

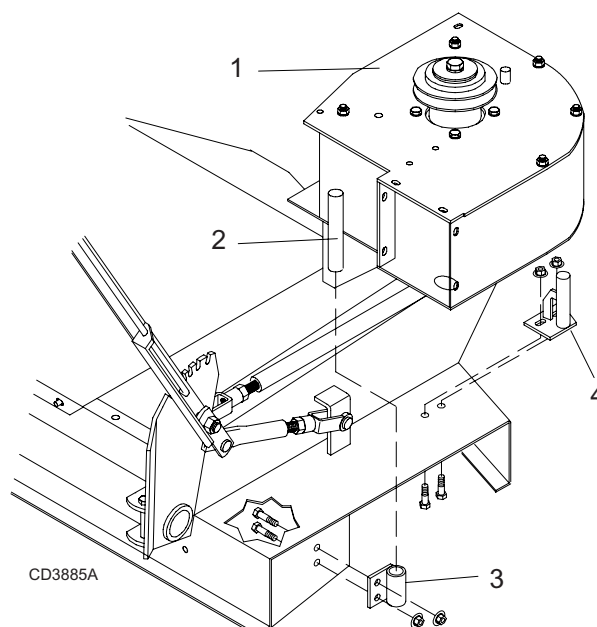

Figure 3. Vacuum Housing Installation

Attach Discharge Chute

WARNING

■ Be sure either the discharge chute, mulching end cap, or complete vacuum attachment is installed and in good condition. Replace if damaged.

1. Remove vacuum housing from deck.
2. Install chute adapter with discharge chute attached.
3. Insert the pivot shaft of chute adapter (55 on page 12) into sleeve of pivot mount (3).
4. Pivot the chute adapter in place so that the clevis on chute adapter slips around clevis shaft (4).
5. Install the 3/8 x 2" hitch pin, to lock the chute adapter into place.

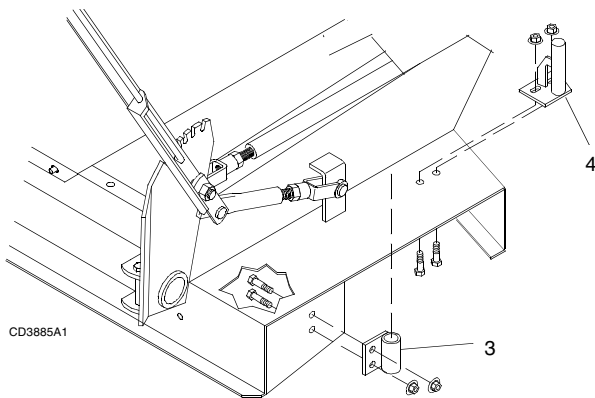

Figure 4. Attachment Points

Install Bearing Mount Assembly

Remove Hardware

1. Remove center and right belt shield.
2. Remove 1/4" cage nuts that hold the right belt shield to the deck.
3. Remove top bolt (A), cupped washer (B), spacer, belt (C) and sheave key from the right spindle assembly. See Figure 5.

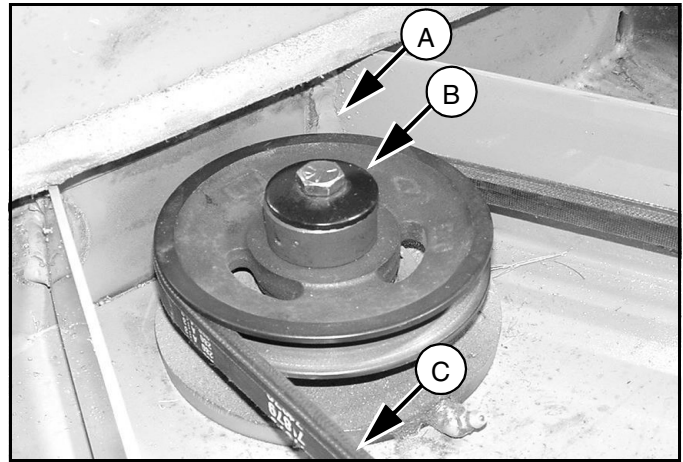

Figure 5. Right spindle assembly

Install Bearing Mount

1. Install lower flex coupler (46) over right spindle sheave.
2. Align keyway of sheave and flex coupler and install 1/4 x 1-1/2" square key (56) that comes with kit.
3. Secure sheave and flex coupler to spindle shaft using bolt (19) and flat washer (45).
4. Place nylon flex coupler sleeve (43) over flex coupler (46) and align grooves.
5. Install 5/16" cage nuts (57) into the four locations on the deck.
6. Install bearing mount (41) by positioning the drive spindle assembly into the nylon flex coupler sleeve (43).
7. Install four 5/16 x 3/4 cap screws, lock washers, and flat washers into the 5/16 cage nuts.

NOTE: The nylon flex coupler should move freely up and down between the two flex coupler hubs.

8. Maintain alignment between the two flex coupler hubs and tighten the four 5/16 cap screws.

NOTE: The four bolts holding the drive spindle on the bearing mount have been left loose to help align the two flex coupler hubs. The nylon flex coupler should move freely up and down approximately 1/16" between the two flex coupler hubs.

9. Maintain alignment between the two flex coupler hubs and tighten the four bolts to the drive spindle.

6 Installation

MAN0116 (Rev. 4/15/2004)

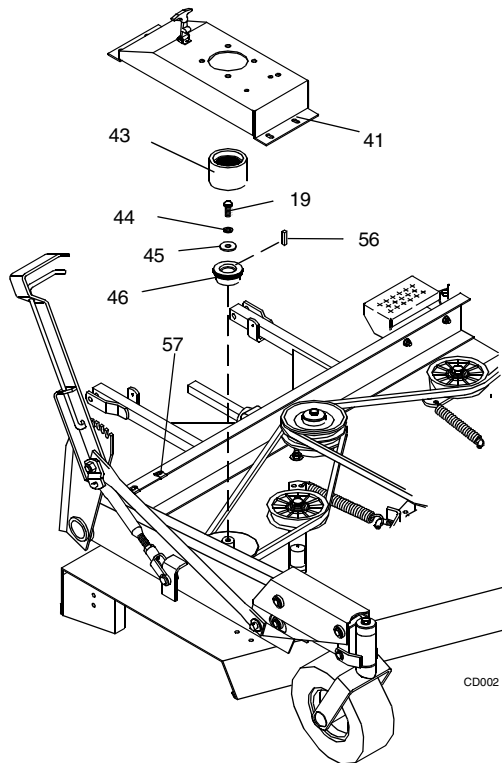

Figure 6. Bearing Mount Assembly Installation

Install Vacuum Drive Belt

1. Install belt (37) over sheaves and idler as shown in Figure 7.
2. Engage belt tension lever (29) as shown in Figure 8.

Remove Vacuum Drive Belt

1. Disengage belt tension lever (29).
2. Release rubber latch on vacuum drive shield (39), Figure 9.
3. Remove belt shield (38) from vacuum housing (38), Figure 9.
4. Remove belt from sheaves and idler.

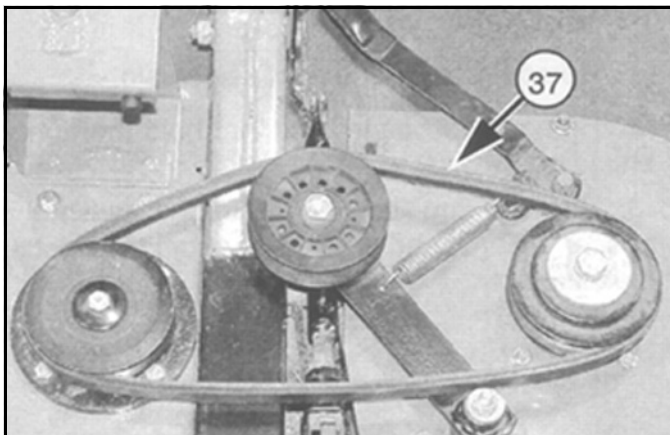

Figure 7. Drive Belt Installation

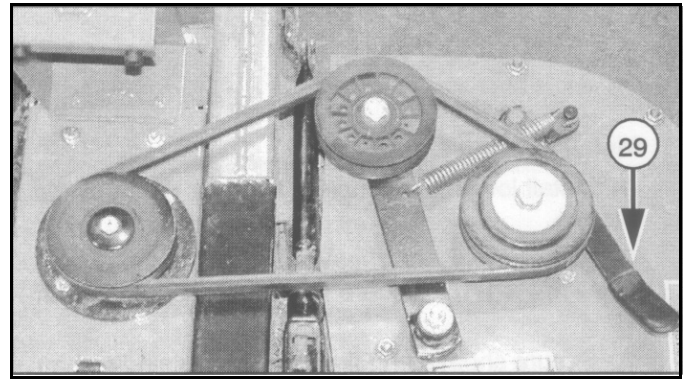

Figure 8. Belt Tension Lever Engaged

Install Belt Shield

NOTE: Check that belt is aligned and parts are installed properly. Test run vacuum housing and bearing mount for proper operation.

1. Install belt shield (38) on vacuum housing using three 5/16 x 1 cap screws, lock washers, and hex nuts.
2. Close vacuum drive shield (39) and secure with rubber draw latch.
3. Make sure belt tension lever is engaged.

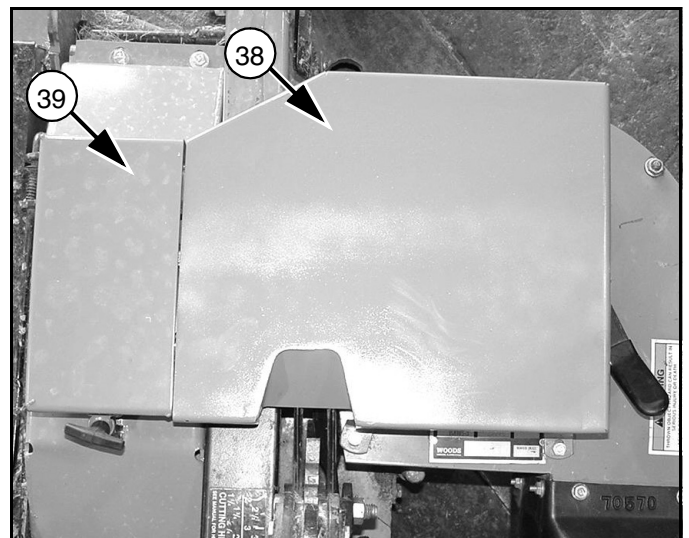

Figure 9. Belt Shield Installed (D5221T Shown)

DEALER CHECK LISTS

PRE-DELIVERY CHECK LIST **(DEALER'S RESPONSIBILITY)**

Inspect the equipment thoroughly after assembly to make sure it is properly set up before delivering it to the customer.

The following check lists are a reminder of points to inspect. Check off each item as it is found satisfactory or after proper adjustment is made.

- ___ Check that shields and guards are properly installed and in good condition. Replace if damaged.
- ___ Check all bolts to be sure they are properly torqued.
- ___ Check that all cotter pins and safety pins are properly installed. Replace if damaged.
- ___ Check and grease all lubrication points as identified in "Service, lubrication information."

DELIVERY CHECK **(DEALER'S RESPONSIBILITY)**

- ___ Show customer how to make adjustments and select proper PTO speed.
- ___ Instruct customer how to lubricate and explain importance of lubrication.
- ___ Present Operator's Manual and request that customer and all operators read it before operating equipment. Point out the manual safety rules, explain their meanings and emphasize the increased safety hazards that exist when safety rules are not followed.
- ___ Make customer aware of optional equipment available so that customer can make proper choices as required.
- ___ Point out all guards and shields. Explain their importance and the safety hazards that exist when not kept in place and in good condition.

SERVICE

Replace Vacuum Housing Bearings

1. Remove vacuum housing from deck.
2. Remove hose adapter (4) from vacuum housing.
3. Remove belt sheave and hardware shown in position (A) from assembly.
4. Remove housing top (23) from vacuum housing.
5. Remove spindle housing (8) by removing hardware (B) from housing top (23).
6. Remove cap screw (19) and washer (45) from bottom of spindle shaft (9) and remove vacuum fan (21).
7. Press spindle shaft through bearings and out of spindle housing.
8. Press bearings (12) from spindle housing.

Install New Bearings

1. Press new bearings (12) in spindle housing. Make sure spacer (10) is installed between bearings.
2. To reassemble vacuum housing, reverse steps 1 through 7. Make sure all hardware is installed correctly. See page 13 for complete parts list.

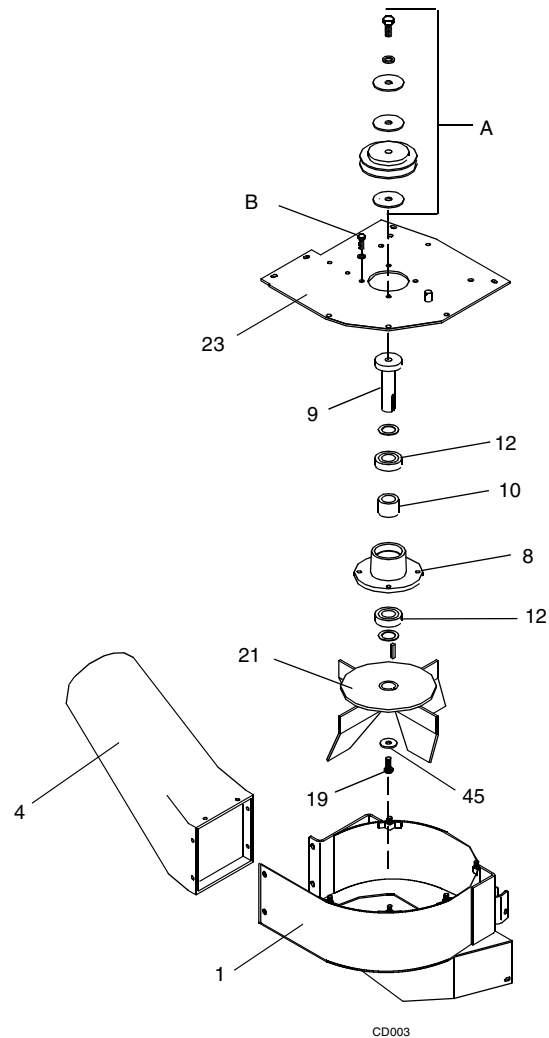

Figure 10

Replace Vacuum Spindle Bearings

1. Remove vacuum housing from deck.
2. Remove bearing mount (41) from Deck. Leave plastic coupler sleeve (43) attached to right deck spindle.
3. Remove spindle assembly (20) from bearing mount.
4. Remove cap screw (19) and cup washer (18) from top of spindle.
5. Remove sheave (16) from spindle shaft (14). A puller maybe required to remove sheave.
6. Press spindle shaft (14) through bearings (51) and out of spindle housing (15).
7. Press bearings (51) from spindle housing.

Install New Bearings

1. Press new bearings (51) in spindle housing. Make sure spacer (10) is installed between bearings.
2. Reverse steps 1 - 6 and reassemble spindle housing. Make sure all hardware is installed correctly. See page -- for complete parts list.
3. Install bearing mount to deck. See "Install Bearing Mount" on page 7.
4. Attach vacuum housing to deck and secure.

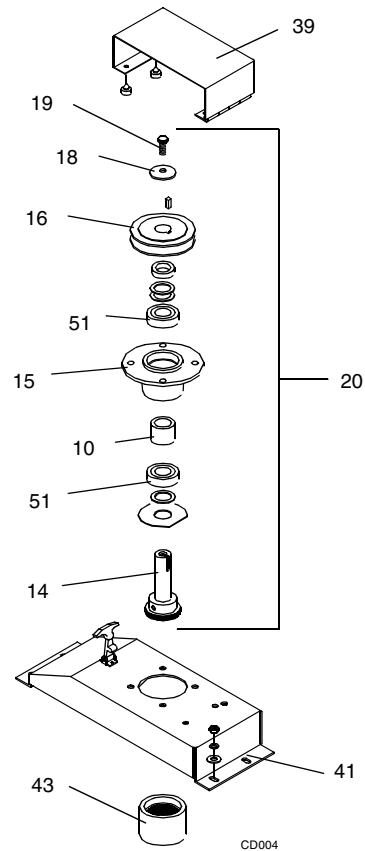
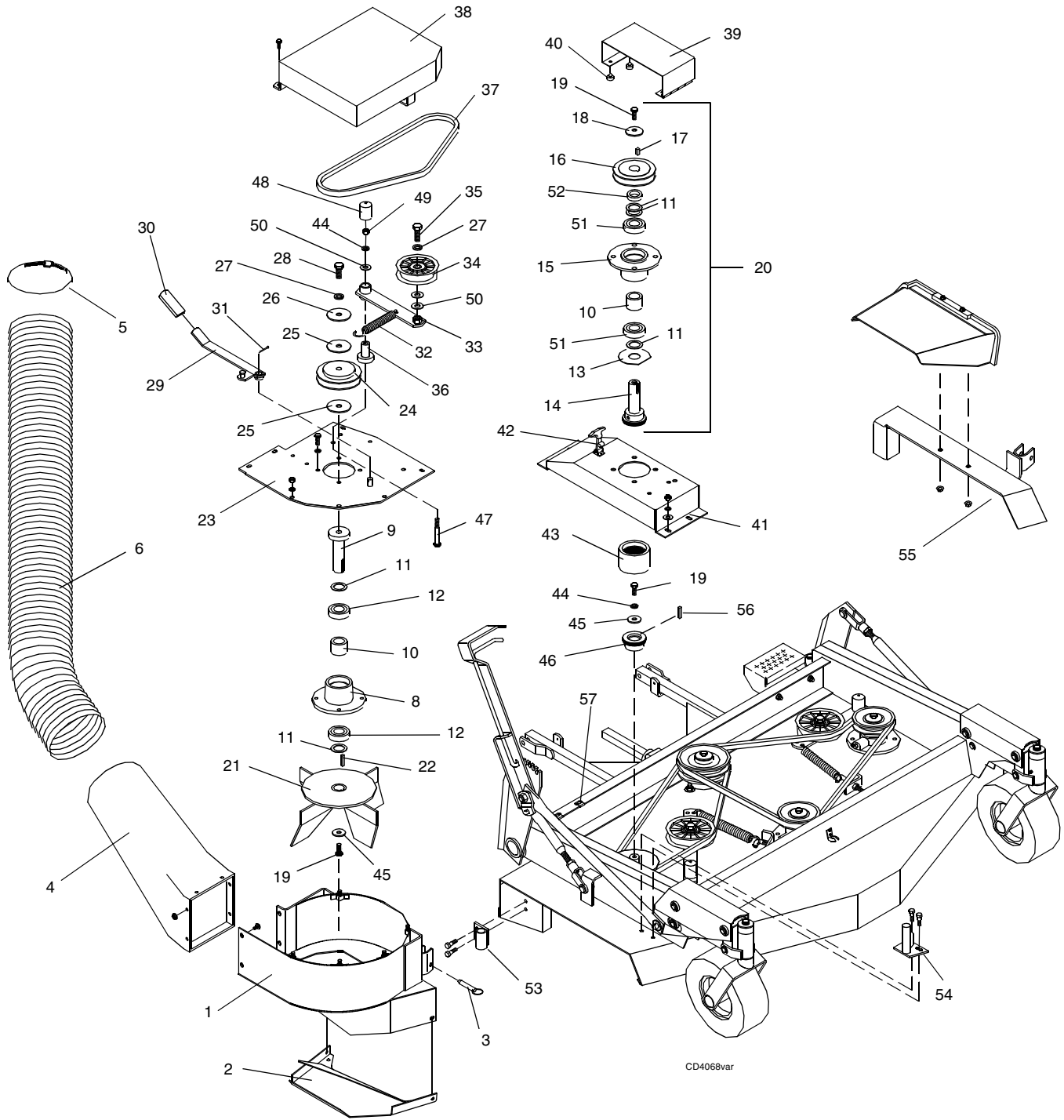

Figure 11. Vacuum Drive Spindle Assembly

NOTES

VACUUM & DRIVE ASSEMBLY



CD4068var

12 Parts

MAN0116 (Rev. 4/15/2004)

VACUUM & DRIVE ASSEMBLY PARTS LIST

Ref Part No.	Description	Ref Part No.	Description
1 71492	Vacuum fan housing	31 3597	1/8 x 1 Cotter pin
2 71493	Angled blower chute	32 70107	Extension spring
3 70565	3/8 x 2 Hitch pin	33 71498	Vacuum idler arm (includes item 33A)
4 70570	Hose adapter tube	33A 70026	Nylon bearing
5 70523	6" Hose clamp	34 70607	Idler
6 1001018	6 x 64" Hose (15 cu. ft. hopper)	35 6100	* 1/2 NC x 1-1/4 Hex head cap screw GR5
8 70608	Spindle housing	36 71430	Pedestal bearing
9 72081	Blower spindle shaft, 25 mm	37 70581	Vacuum belt (for 52" mowers)
10 72099	Spacer	37 71506	Vacuum belt (for 61" mower)
11 70601	8 GA Washer	38 74027	Vacuum belt shield (for 52" mowers)
12 71984	25 mm Bearing	38 74028	Vacuum belt shield (for 61" mower)
13 71495	1" ID Washer	39 70576	Vacuum drive shield
14 72702	Spindle shaft assembly (includes items 14A, 14B, & 14C)	40 70175	Rubber bumper
14A 72606	Shaft, 25 mm	41 74031	Vacuum drive mount (for 52" mowers)
14B 72607	Upper flex coupler, 25 mm	41 74032	Vacuum drive mount (for 61" mower)
14C 11880	5/16 x 2 Spiral roll pin	42 70002	Rubber draw latch
15 70590	Spindle housing	43 72658	Coupler sleeve
16 71996	Sheave, 25 mm (for 52" mowers)	44 838	* 3/8 Lockwasher
16 71999	Sheave, 25 mm (for 61" mower)	45 70036	Flat washer
17 70072	1/4 x.69 Square key	46 72656	Lower flex coupler, 25 mm
18 70005	Cupped washer	47 7747	3/8 NC x 3 Hex head cap screw GR5
19 64518	3/8 NF x 1 Hex head cap screw GR5	48 71446	Vinyl cap
21 72186	Vacuum fan	49 835	* 3/8 NC Hex nut
22 3886	1/4 x 1-1/4 Square key	50 3598	* 1/2 SAE Flat washer
23 71497	Vacuum blower top	51 71985	Bearing, 25 mm
24 70575	Sheave	52 70086	3/8 Spacer
25 70010	1/2 x 2-1/2 Fiber washer	53 70562	Pivot mount
26 70602	1/2 x 2-1/4 Washer	54 70564	Clevis shaft
27 855*	1/2 Lockwasher	55 73253	Chute adapter
28 70012	1/2 NF x 2 Hex head cap screw	56 480752	1/4 x 1-1/2 Square key
29 70574	Belt tensioner arm	57 74047	5/16 NC Cage nut
30 70165	Handle grip		

* Obtain Locally

BOLT TORQUE CHART

Always tighten hardware to these values unless a different torque value or tightening procedure is listed for a specific application.

Fasteners must always be replaced with the same grade as specified in the manual parts list.

Always use the proper tool for tightening hardware: SAE for SAE hardware and Metric for metric hardware.

Make sure fastener threads are clean and you start thread engagement properly.

All torque values are given to specifications used on hardware defined by SAE J1701 & J1701M JUL96.

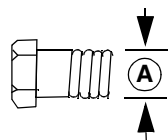

SAE SERIES TORQUE CHART

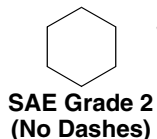

SAE Bolt Head Identification



**SAE Grade 5
(3 Radial Dashes)**



**SAE Grade 8
(6 Radial Dashes)**

A Diameter (Inches)	Wrench Size	MARKING ON HEAD					
		SAE 2		SAE 5		SAE 8	
		lbs-ft	N-m	lbs-ft	N-m	lbs-ft	N-m
1/4"	7/16"	6	8	10	13	14	18
5/16"	1/2"	12	17	19	26	27	37
3/8"	9/16"	23	31	35	47	49	67
7/16"	5/8"	36	48	55	75	78	106
1/2"	3/4"	55	75	85	115	120	163
9/16"	13/16"	78	106	121	164	171	232
5/8"	15/16"	110	149	170	230	240	325
3/4"	1-1/8"	192	261	297	403	420	569
7/8"	1-5/16"	306	416	474	642	669	907
1"	1-1/2"	467	634	722	979	1020	1383

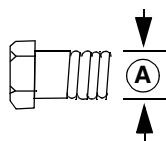

METRIC SERIES TORQUE CHART

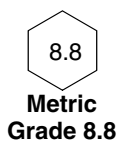

Metric Bolt Head Identification



**10.9
Metric
Grade 10.9**

A Diameter & Thread Pitch (Millimeters)	Wrench Size	COARSE THREAD				FINE THREAD				A Diameter & Thread Pitch (Millimeters)
		MARKING ON HEAD				MARKING ON HEAD				
		Metric 8.8		Metric 10.9		Metric 8.8		Metric 10.9		
		N-m	lbs-ft	N-m	lbs-ft	N-m	lbs-ft	N-m	lbs-ft	
6 x 1.0	10 mm	8	6	11	8	8	6	11	8	6 x 1.0
8 x 1.25	13 mm	20	15	27	20	21	16	29	22	8 x 1.0
10 x 1.5	16 mm	39	29	54	40	41	30	57	42	10 x 1.25
12 x 1.75	18 mm	68	50	94	70	75	55	103	76	12 x 1.25
14 x 2.0	21 mm	109	80	151	111	118	87	163	120	14 x 1.5
16 x 2.0	24 mm	169	125	234	173	181	133	250	184	16 x 1.5
18 x 2.5	27 mm	234	172	323	239	263	194	363	268	18 x 1.5
20 x 2.5	30 mm	330	244	457	337	367	270	507	374	20 x 1.5
22 x 2.5	34 mm	451	332	623	460	495	365	684	505	22 x 1.5
24 x 3.0	36 mm	571	421	790	583	623	459	861	635	24 x 2.0
30 x 3.0	46 mm	1175	867	1626	1199	1258	928	1740	1283	30 x 2.0

Typical Washer Installations

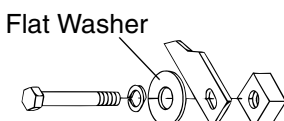
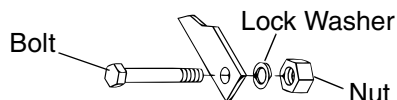

8/9/00

BOLT SIZE CHART

NOTE: Chart shows bolt thread sizes and corresponding head (wrench) sizes for standard SAE and metric bolts.

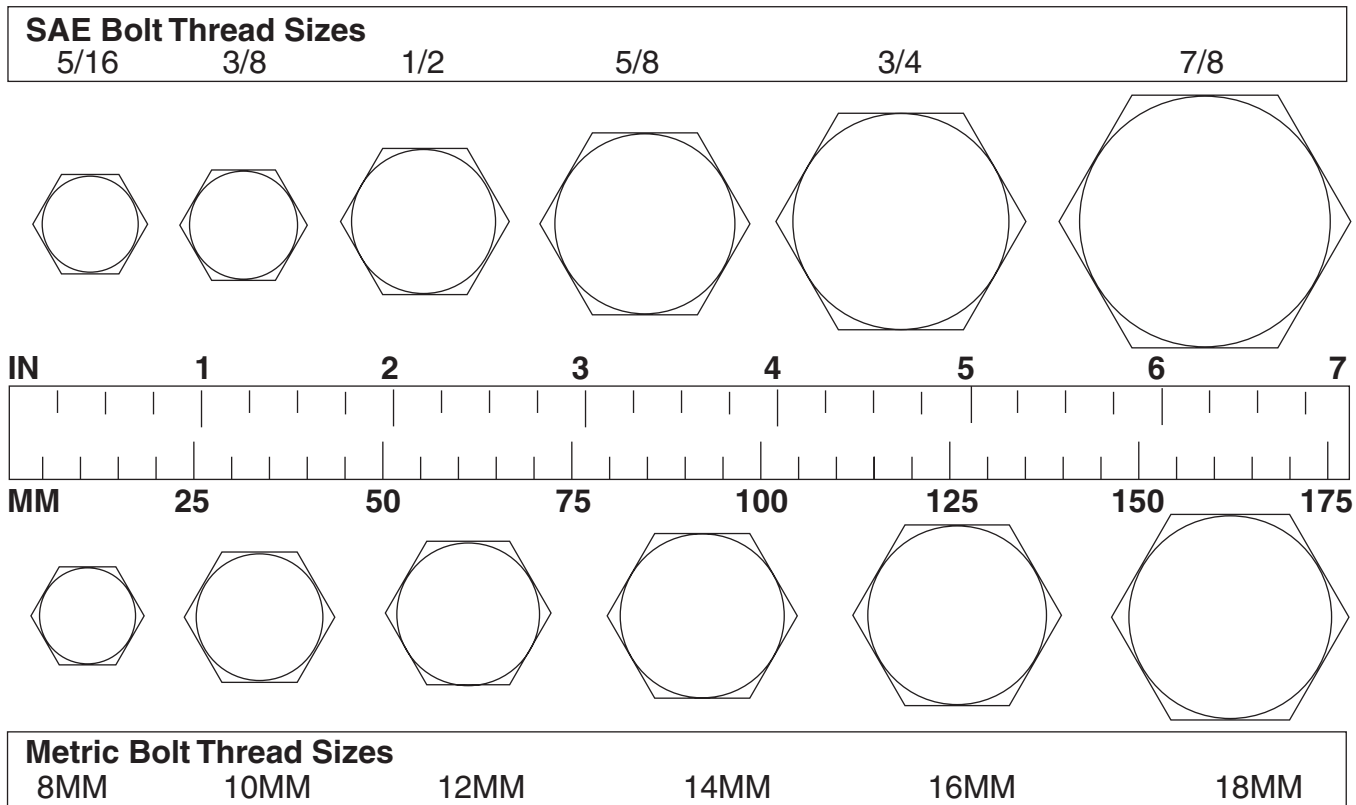

ABBREVIATIONS

AG.....	Agriculture	NC.....	National Coarse
ATF.....	Automatic Transmission Fluid	NF.....	National Fine
BSPP.....	British Standard Pipe Parallel	NPSM.....	National Pipe Straight Mechanical
BSPTM.....	British Standard Pipe Tapered Male	NPT.....	National Pipe Tapered
CV.....	Constant Velocity	NPT SWF.....	National Pipe Tapered Swivel Female
CCW.....	Counter-Clockwise	ORBM.....	O-Ring Boss - Male
CW.....	Clockwise	P.....	Pitch
F.....	Female	PBY.....	Power-Beyond
GA.....	Gauge	psi.....	Pounds per Square Inch
GR (5, etc.).....	Grade (5, etc.)	PTO.....	Power Take Off
HHCS.....	Hex Head Cap Screw	QD.....	Quick Disconnect
HT.....	Heat-Treated	RH.....	Right Hand
JIC.....	Joint Industry Council 37° Degree Flare	ROPS.....	Roll-Over Protective Structure
LH.....	Left Hand	RPM.....	Revolutions Per Minute
LT.....	Left	RT.....	Right
m.....	Meter	SAE.....	Society of Automotive Engineers
mm.....	Millimeter	UNC.....	Unified Coarse
M.....	Male	UNF.....	Unified Fine
MPa.....	Mega Pascal	UNS.....	Unified Special
N.....	Newton		



LIMITED WARRANTY

(Mow'n Machine Replacement Parts)

WEC Company, d/b/a Woods Equipment Company ("WOODS") warrants replacement parts for Mow'n Machines and attachments to be free from defect in material and workmanship for a period of ninety (90) days from the date of delivery of the product to the original purchaser.

IMPLIED WARRANTIES OF MERCHANTABILITY AND/OR FITNESS FOR A PARTICULAR PURPOSE ARE LIMITED IN DURATION TO A PERIOD OF NINETY (90) DAYS FROM THE DATE OF DELIVERY OF THE PRODUCT TO THE ORIGINAL PURCHASER. Some states do not allow limitations on how long an implied warranty lasts, so the above limitation may not apply to you.

This Warranty is extended solely to the original purchaser of the product. Should the original purchaser sell or otherwise transfer the product to a third party, this Warranty does not transfer to the third party purchaser in any way. There are no third party beneficiaries of this Warranty.

This Warranty does not cover normal wear or tear, or normal maintenance items, or any damage, failure or loss caused by improper operation, improper maintenance, misuse, or an accident.

WOODS' obligation under this Warranty is limited to, at WOODS' option, the repair or replacement, free of charge, of the product if the product is defective or in noncompliance with this Warranty. **The product must be returned to WOODS with proof of purchase within thirty (30) days after such defect or noncompliance is discovered or should have been discovered, routed through the dealer and distributor from whom the purchase was made, transportation charges prepaid.** WOODS shall complete such repair or replacement within a reasonable time after WOODS receives the product.

WOODS shall not be liable for any incidental or consequential losses, damages or expenses, arising directly or indirectly from the product, whether such claim is based upon breach of contract, breach of warranty, negligence, strict liability in tort or any other legal theory. Without limiting the foregoing, WOODS shall not be liable for any damages relating to (i) lost profits, business, revenues or goodwill; (ii) any expense or loss incurred for labor, supplies, substitute machinery or rental; or (iii) any other type of damage to property or economic loss. Some states do not allow the exclusion or limitation of incidental or consequential damages, so the above limitations may not apply to you.

No agent, representative, dealer, distributor, service person, salesperson, or employee of any company, including without limitation, WOODS, its authorized dealers, distributors, and service centers, is authorized to alter, modify, or enlarge this Warranty.

This Warranty gives you specific legal rights, and you may also have other rights which may vary from state to state.

Answers to any questions regarding warranty service and locations may be obtained by contacting:

Woods Equipment Company

2606 South Illinois Route 2
Post Office Box 1000
Oregon, Illinois 61061

815-732-2141 tel
815-732-7580 fax
www.woodsonline.com

**ALITEC
ALLOWAY
BMP
CENTRAL FABRICATORS
GANNON
GILL
WAIN-ROY
WOODS**



LIMITED WARRANTY

(Mow'n Machines)

Please Enter Information Below and Save For Future Reference.

Date Purchased: _____ From (Dealer): _____
Model Number: _____ Serial Number: _____

WHAT IS COVERED

WEC Company, d/b/a Woods Equipment Company ("WOODS"), warrants Mow'n Machines and attachments to be free from defect in material and workmanship for the warranty periods listed below.

FOR HOW LONG

Mow'n Machine Model #6170 & attachments are warranted two (2) years from the date of delivery to the original purchaser when used in residential applications. They are warranted for one (1) year from the date of delivery to the original purchaser when used in commercial, industrial or institutional applications.

Mow'n Machine Models #M1952K, #M2560K, and #M2760 & attachments are warranted for two (2) years from the date of delivery to the original purchaser or 1000 hours of operation, whichever occurs first.

Mow'n Machine Models #F21D, #F23, #F25, #F25L, and #F27 & attachments are warranted for two (2) years from the date of delivery to the original purchaser or 600 hours of operation, whichever occurs first.

IMPLIED WARRANTIES OF MERCHANTABILITY AND/OR FITNESS FOR A PARTICULAR PURPOSE ARE LIMITED IN DURATION TO THE DURATION OF THE WRITTEN WARRANTY PERIODS LISTED ABOVE. Some states do not allow limitations on how long an implied warranty lasts, so the above limitation may not apply to you.

WHO IS COVERED

This Warranty is extended solely to the original purchaser of the product. Should the original purchaser sell or otherwise transfer the product to a third party, this Warranty does not transfer to the third party purchaser in any way. There are no third party beneficiaries of this Warranty.

WHAT IS NOT COVERED

This Warranty does not cover normal wear or tear, or normal maintenance items, or any damage, failure or loss caused by:

1. Improper operation, improper maintenance, misuse, or an accident;
2. Any modification or repair by someone other than WOODS, a WOODS authorized dealer or distributor, and/or a WOODS authorized service center; or
3. Repairs made with parts other than those obtainable through WOODS.

WOODS makes no warranty, express or implied, with respect to engines, batteries, tires or other parts or accessories not manufactured by WOODS. Warranties for these items, if any, are provided separately by their respective manufacturers.

WHAT WOODS WILL DO TO CORRECT PROBLEMS

WOODS' obligation under this Warranty is limited to, at WOODS' option, the repair or replacement, free of charge, of the product if the product is defective or in noncompliance with this Warranty. **The product must be returned to WOODS with proof of purchase within thirty (30) days after such defect or noncompliance is discovered or should have been discovered, routed through the dealer and distributor from whom the purchase was made, transportation charges prepaid.** WOODS shall complete such repair or replacement within a reasonable time after WOODS receives the product.

OTHER LIMITATIONS

WOODS shall not be liable for any incidental or consequential losses, damages or expenses, arising directly or indirectly from the product, whether such claim is based upon breach of contract, breach of warranty, negligence, strict liability in tort or any other legal theory. Without limiting the foregoing, WOODS shall not be liable for any damages relating to (i) lost profits, business, revenues or goodwill; (ii) any expense or loss incurred for labor, supplies, substitute machinery or rental; or (iii) any other type of damage to property or economic loss. Some states do not allow the exclusion or limitation of incidental or consequential damages, so the above limitations may not apply to you.

No agent, representative, dealer, distributor, service person, salesperson, or employee of any company, including without limitation, WOODS, its authorized dealers, distributors, and service centers, is authorized to alter, modify, or enlarge this Warranty.

HOW STATE LAW APPLIES

This Warranty gives you specific legal rights, and you may also have other rights which may vary from state to state.

QUESTIONS

Answers to any questions regarding warranty service and locations may be obtained by contacting:

Woods Equipment Company

2606 South Illinois Route 2
Post Office Box 1000
Oregon, Illinois 61061

815-732-2141 tel
815-732-7580 fax
www.woodsonline.com



**ALITEC
ALLOWAY
BMP
CENTRAL FABRICATORS
GANNON
GILL
WAIN-ROY
WOODS**

PART NO.

MAN0116

**Woods Equipment
Company**

2606 Illinois Route 2 South
Post Office Box 1000
Oregon, Illinois 61061

815-732-2141 tel
815-732-7580 fax

WOODS®

© 2001 Woods Equipment Company. All rights reserved.

Free Manuals Download Website

<http://myh66.com>

<http://usermanuals.us>

<http://www.somanuals.com>

<http://www.4manuals.cc>

<http://www.manual-lib.com>

<http://www.404manual.com>

<http://www.luxmanual.com>

<http://aubethermostatmanual.com>

Golf course search by state

<http://golfingnear.com>

Email search by domain

<http://emailbydomain.com>

Auto manuals search

<http://auto.somanuals.com>

TV manuals search

<http://tv.somanuals.com>