



Model W1701

3/4 HP SHAPER

MANUAL UPDATE

This update covers changes made to the owner's manual after it was printed. Keep this update with your owner's manual for future reference. Before operating your new machine, you **MUST** read and understand this insert and the entire Model W1701 manual to reduce the risk of injury from improper use or setup. *If you have questions, contact Tech Support at (360) 734-3482 or by email at tech_support@shopfox.biz.*

What has changed?

The inventory has changed to reflect an improved tool set now included with the Model W1701. All page references made on this insert refer to the pages in the original Model W1701 manual.

Removed Inventory

Refer to Inventory List on Page 9. These items are no longer included with the machine.

- D. Special 26mm Flat Wrench 1
- E. Wrench Set (8mm, 14mm, 30mm)..... 1

Additional Inventory (Figure 1)

The following items are now included with the Model W1701.

- V. Combo Wrench 8/10mm..... 1
- W. Combo Wrench 12/14mm 1
- X. Combo Wrench 27/30mm 1

Additional Inventory Breakdown & Parts List

Use this breakdown and parts list together with those on Pages 27-29.

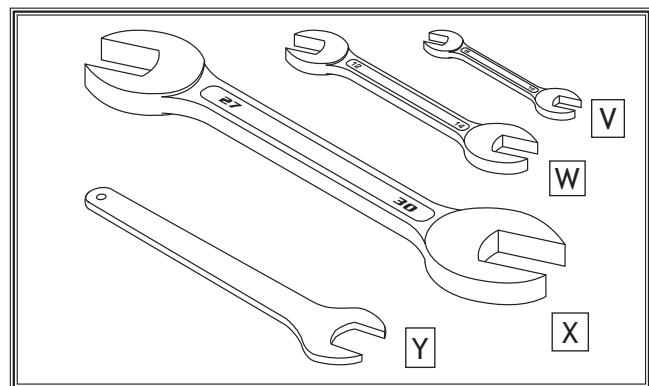
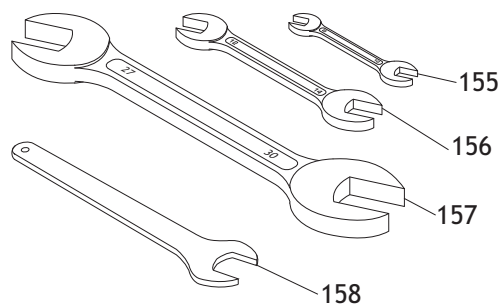

Figure 1. Additional inventory.

REF	PART #	DESCRIPTION
155	XPWR810	COMBO WRENCH 8/10MM
156	XPWR1214	WRENCH 12 X 14
157	X1701157	WRENCH 27/30MM
158	X1701158	FLAT WRENCH 27MM

COPYRIGHT © FEBRUARY, 2008 BY WOODSTOCK INTERNATIONAL, INC.

WARNING: NO PORTION OF THIS MANUAL MAY BE REPRODUCED IN ANY SHAPE OR FORM WITHOUT

#10453JB

THE WRITTEN APPROVAL OF WOODSTOCK INTERNATIONAL, INC.

Printed in China

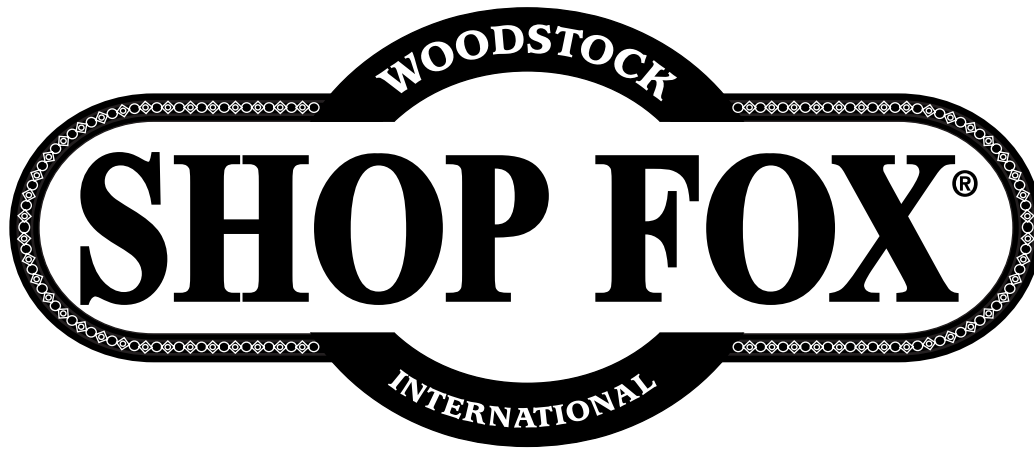

MODEL W1701 1 HP SHAPER



OWNER'S MANUAL

Phone: (360) 734-3482 • E-Mail: tech-support@shopfox.biz

COPYRIGHT © AUGUST, 2003 BY WOODSTOCK INTERNATIONAL, INC. REVISED MARCH 2006 (TR).

WARNING: NO PORTION OF THIS MANUAL MAY BE REPRODUCED IN ANY SHAPE OR FORM WITHOUT

THE WRITTEN APPROVAL OF WOODSTOCK INTERNATIONAL, INC.

#6915CR

Printed in China

WARNING!

This manual provides critical safety instructions on the proper setup, operation, maintenance and service of this machine/equipment.

Failure to read, understand and follow the instructions given in this manual may result in serious personal injury, including amputation, electrocution or death.

The owner of this machine/equipment is solely responsible for its safe use. This responsibility includes but is not limited to proper installation in a safe environment, personnel training and usage authorization, proper inspection and maintenance, manual availability and comprehension, application of safety devices, blade/cutter integrity, and the usage of personal protective equipment.

The manufacturer will not be held liable for injury or property damage from negligence, improper training, machine modifications or misuse.

WARNING!

Some dust created by power sanding, sawing, grinding, drilling, and other construction activities contains chemicals known to the State of California to cause cancer, birth defects or other reproductive harm. Some examples of these chemicals are:

- Lead from lead-based paints.
- Crystalline silica from bricks, cement and other masonry products.
- Arsenic and chromium from chemically-treated lumber.

Your risk from these exposures varies, depending on how often you do this type of work. To reduce your exposure to these chemicals: Work in a well ventilated area, and work with approved safety equipment, such as those dust masks that are specially designed to filter out microscopic particles.

Contents

- INTRODUCTION** 2
 - Woodstock Technical Support 2
 - Specifications 2
- SAFETY** 3
 - Standard Safety Instructions 3
 - Additional Safety Instructions for Shapers 5
 - Avoiding Potential Injuries 6
- ELECTRICAL** 7
 - 110V Operation 7
 - Extension Cords 7
 - Grounding 7
- SET UP** 8
 - Unpacking 8
 - Inventory 8
 - Inventory List 9
 - Machine Placement 9
 - Cleaning Machine 9
 - Assembly 10
 - Test Run 11
- OPERATIONS** 12
 - General 12
 - Cutters vs. Router Bits 12
 - Spindle Elevation 13
 - Spindle Direction 13
 - Fence Positioning 14
 - Fence Alignment 14
 - Table Inserts 14
 - Cutter Installation 15
 - Router Bit Installation 17
 - Straight Shaping 18
 - Templates 19
 - Freehand Shaping 20
- MAINTENANCE** 21
 - General 21
 - Table & Base 21
 - Lubrication 21
 - Maintenance Schedule 21
- SERVICE** 22
 - General 22
 - Belt Adjustment 22
 - Table Spacer Kit 23
 - Spindle Cartridge Replacement 24
 - Resurfacing Fence 25
 - Electrical Components & Wiring 26
- PARTS** 27
 - Parts List 28

USE THE QUICK GUIDE PAGE LABELS TO SEARCH OUT INFORMATION FAST!

INTRODUCTION

Woodstock Technical Support

We stand behind our machines! In the event that questions arise about your machine, parts are missing, or a defect is found, please contact Woodstock International Technical Support at (360) 734-3482 or send e-mail to: tech-support@shopfox.biz. Our knowledgeable staff will help you troubleshoot problems and send out parts for warranty claims.

If you need the latest edition of this manual, you can download it from <http://www.shopfox.biz>. If you have comments about this manual, please contact us at:

Woodstock International, Inc.
Attn: Technical Documentation Manager
P.O. Box 2309
Bellingham, WA 98227

Specifications

Motor Size	1HP, 110V, 60 Hz Single-Phase
Motor Speed	3,450 RPM
Amps.....	13
Spindle Size	1/2"
Spindle Max Cutter Height W/Bushings, Nuts, and Rub Collar	2 1/2"
Maximum Cutter Diameter.....	2 7/8"
Spindle Travel.....	7/8"
Spindle Speed	13,200 RPM
Table Size	24" Wide x 19" Deep
Stand	Powder Coated Paint
Footprint.....	18 7/8" Wide x 16 5/8" Deep
Dust Port.....	N/A
Power Transfer	Belt Drive
Bearings.....	Shielded and Permanently Lubricated Ball Bearings
Switch	Forward and Reverse Toggle
Machine Weight.....	200 lbs.

SAFETY

**READ MANUAL BEFORE OPERATING MACHINE.
FAILURE TO FOLLOW INSTRUCTIONS BELOW WILL
RESULT IN PERSONAL INJURY.**

DANGER

Indicates an imminently hazardous situation which, if not avoided, WILL result in death or serious injury.

WARNING

Indicates a potentially hazardous situation which, if not avoided, COULD result in death or serious injury.

CAUTION

Indicates a potentially hazardous situation which, if not avoided, MAY result in minor or moderate injury.

NOTICE

This symbol is used to alert the user to useful information about proper operation of the equipment, and/or a situation that may cause damage to the machinery.

Standard Safety Instructions

1. **READ THROUGH THE ENTIRE MANUAL BEFORE STARTING MACHINERY.** Machinery presents serious injury hazards to untrained users.
2. **ALWAYS USE ANSI APPROVED SAFETY GLASSES WHEN OPERATING MACHINERY.** Everyday eye-glasses only have impact resistant lenses—they are NOT safety glasses.
3. **ALWAYS WEAR AN NIOSH APPROVED RESPIRATOR WHEN OPERATING MACHINERY THAT PRODUCES DUST.** Wood dust is a carcinogen and can cause cancer and severe respiratory illnesses.
4. **ALWAYS USE HEARING PROTECTION WHEN OPERATING MACHINERY.** Machinery noise can cause permanent hearing damage.
5. **WEAR PROPER APPAREL.** DO NOT wear loose clothing, gloves, neckties, rings, or jewelry which may get caught in moving parts. Wear protective hair covering to contain long hair and wear non-slip footwear.
6. **NEVER OPERATE MACHINERY WHEN TIRED, OR UNDER THE INFLUENCE OF DRUGS OR ALCOHOL.** Be mentally alert at all times when running machinery.
7. **ONLY ALLOW TRAINED AND PROPERLY SUPERVISED PERSONNEL TO OPERATE MACHINERY.** Make sure operation instructions are safe and clearly understood.
8. **KEEP CHILDREN AND VISITORS AWAY.** Keep all children and visitors a safe distance from the work area.
9. **MAKE WORKSHOP CHILD PROOF.** Use padlocks, master switches, and remove start switch keys.

10. **NEVER LEAVE WHEN MACHINE IS RUNNING.** Turn power off and allow all moving parts to come to a complete stop before leaving machine unattended.
11. **DO NOT USE IN DANGEROUS ENVIRONMENTS.** DO NOT use machinery in damp, wet locations, or where any flammable or noxious fumes may exist.
12. **KEEP WORK AREA CLEAN AND WELL LIT.** Clutter and dark shadows may cause accidents.
13. **USE A GROUNDED EXTENSION CORD RATED FOR THE MACHINE AMPERAGE.** Undersized cords over-heat and lose power. Replace extension cords if they become damaged. DO NOT use extension cords for 220V machinery.
14. **ALWAYS DISCONNECT FROM POWER SOURCE BEFORE SERVICING MACHINERY.** Make sure switch is in OFF position before reconnecting.
15. **MAINTAIN MACHINERY WITH CARE.** Keep blades sharp and clean for best and safest performance. Follow instructions for lubricating and changing accessories.
16. **MAKE SURE GUARDS ARE IN PLACE AND WORK CORRECTLY BEFORE USING MACHINERY.**
17. **REMOVE ADJUSTING KEYS AND WRENCHES.** Make a habit of checking for keys and adjusting wrenches before turning machinery ON.
18. **CHECK FOR DAMAGED PARTS BEFORE USING MACHINERY.** Check for binding and alignment of parts, broken parts, part mounting, loose bolts, and any other conditions that may affect machine operation. Repair or replace damaged parts.
19. **USE RECOMMENDED ACCESSORIES.** Refer to the instruction manual for recommended accessories. The use of improper accessories may cause risk of injury.
20. **DO NOT FORCE MACHINERY.** Work at the speed for which the machine or accessory was designed.
21. **SECURE WORKPIECE.** Use clamps or a vise to hold the workpiece when practical. A secured workpiece protects your hands and frees both hands to operate the machine.
22. **DO NOT OVERREACH.** Keep proper footing and balance at all times.
23. **MANY MACHINES WILL EJECT THE WORKPIECE TOWARD THE OPERATOR.** Know and avoid conditions that cause the workpiece to "kickback."
24. **ALWAYS LOCK MOBILE BASES (IF USED) BEFORE OPERATING MACHINERY.**
25. **BE AWARE THAT CERTAIN DUST MAY BE HAZARDOUS** to the respiratory systems of people and animals, especially fine dust. Make sure you know the hazards associated with the type of dust you will be exposed to and always wear a respirator approved for that type of dust.

Additional Safety Instructions for Shapers

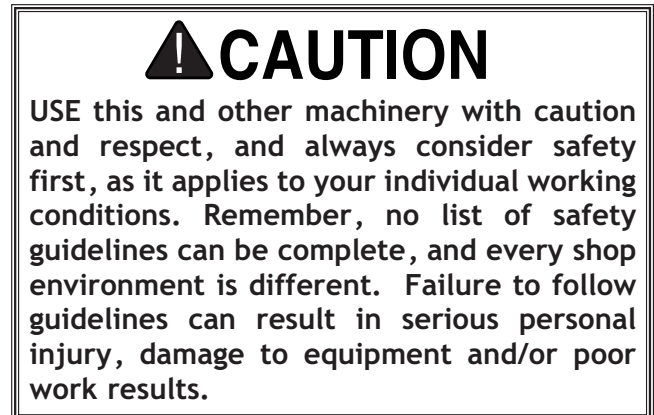
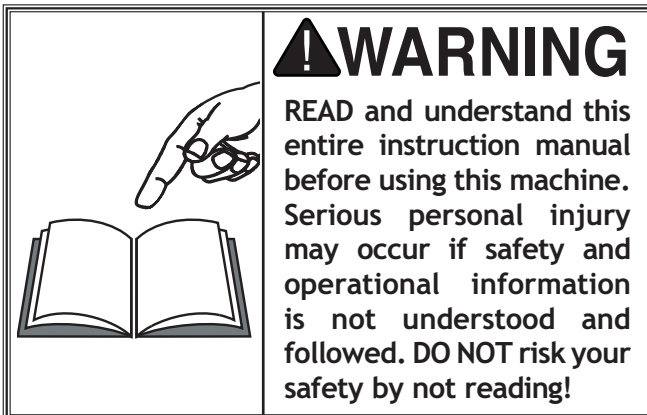

1. **KEEPING HANDS SAFE:** Never pass your hands near or directly over or in front of the cutter. As one hand approaches the 12-inch radius point, move it in an arc motion away from the cutter to the outfeed side and reposition that hand more than 12 inches beyond the cutter.
2. **HOLDING AND UNSAFE WORKPIECE:** **DO NOT** shape stock shorter than 12 inches without special fixtures or jigs. Where practical, shape longer stock and cut to size.
3. **CUTTER POSITIONING:** Keep the cutters on the underside of the workpiece whenever possible to reduce operator exposure to the moving cutter.
4. **TESTING FOR CLEARANCE:** Unplug the shaper, and always rotate the spindle by hand to test any new setup to ensure proper cutter clearance before starting the shaper.
5. **SAFELY STARTING AND FEEDING WORKPIECE:** When shaping contoured work and using a rub collar, **NEVER** start shaping at a corner. See the rub collar section further on in the manual. The danger of kick-back is increased when the stock has knots, holes, or foreign objects in it.
6. **PREPARING A WORKPIECE:** Always run warped stock through a jointer before you run it through the shaper. A warped workpiece is difficult to process, which increases the risk of an accident.
7. **CUTTER EXPOSURE:** Keep any unused portion of the cutter below the table surface.
8. **AVOIDING AN OVERLOAD:** Never attempt to remove too much material in one pass. Several light passes are safer and give a cleaner finish.
9. **SAFELY FEEDING A WORKPIECE:** In most applications it is advisable to use a push stick as a safety device; in others it can be quite dangerous. If the push stick comes in contact with the cutter on the end grain, it can be violently propelled from your hand—potentially causing serious injury. We recommend using some type of fixture, jig, or hold-down device as a safer alternative. And **ALWAYS** use a guard or other type of protective device at all times.
10. **AVOIDING CUTTER AND WORKPIECE GRAB:** Always make sure cutter is positioned in the correct direction before starting shaper, and always feed against the rotation of the cutter.
11. **SAFELY USING ALTERNATE TABLE CONFIGURATIONS:** Always use overhead guard when the fence is not in place. The overhead guard reduces the risk of contacting the cutterhead.
12. **SAFE CUTTER INSTALLATION:** Never operate the shaper without verifying that the spindle nut is tight. A tight spindle nut reduces the risk of the cutter or rub collars flying off during operation.

Avoiding Potential Injuries



Figure 1. Use a SHOP FOX® Featherboard as anti-kick back protection.



Figure 4. Use SHOP FOX® BOARD BUDDIES® for holding down the workpiece.



Figure 2. Use rubberized SHOP FOX® Push Blocks to grip the workpiece when cutting.



Figure 5. Use a SHOP FOX® Right Angle Jig when making special cuts without a safety guard.



Figure 3. Use the smallest insert the cutter will allow to keep woodchips away from the inside of shaper.



Figure 6. Unplug the shaper whenever making adjustments or changing cutters.

ELECTRICAL

110V Operation

The SHOP FOX® Model W1701 is prewired for 110 volt operation. The motor supplied with your new Machine Type is rated at 1 HP and will draw approximately 13 amps. A 5-15 plug is included for your machine and is intended to be plugged into a matching 5-15 receptacle.

Connect your machine to a circuit (wire, breaker, plug, receptacle) that is rated for at least 15 amps.

We recommend connecting this machine to a dedicated circuit with a verified ground, using the circuit breaker size given below. Never replace a circuit breaker with one of higher amperage without consulting a qualified electrician to ensure compliance with wiring codes.

If you are unsure about the wiring codes in your area or you plan to connect your machine to a shared circuit, you may create a fire hazard—consult a qualified electrician to reduce this risk.

Extension Cords

When it is necessary to use an extension cord, use the following guidelines:

- Use cords rated for Standard Service
- Never exceed a length of 100 feet
- Use cords with 12 ga. wire or bigger
- Ensure cord has a ground wire and pin
- Do not use cords in need of repair

Grounding

This machine must be grounded! The electrical cord supplied with this machine comes with a grounding pin. Do not remove it. If your outlet does not accommodate a ground pin, have it replaced by a qualified electrician or have an appropriate adapter installed.

Note: When using an adapter, the adapter must be grounded.

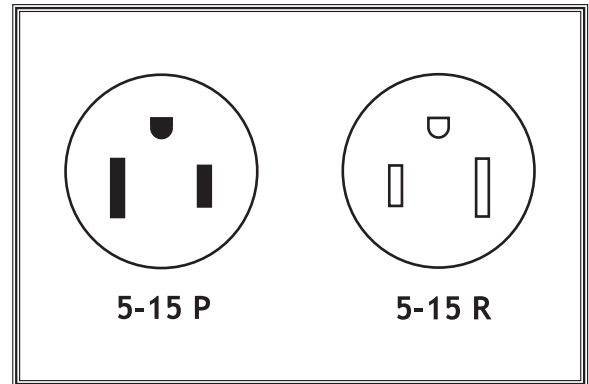
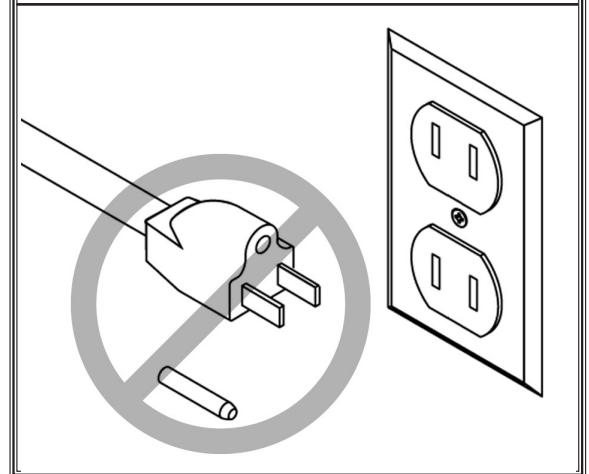

Figure 7. Typical 110V 3-prong plug and outlet.

⚠ WARNING

This equipment must be grounded. Verify that any existing electrical outlet and circuit you intend to plug into is actually grounded. If it is not, it will be necessary to run a separate 12 AWG copper grounding wire from the outlet to a known ground. Under no circumstances should the grounding pin be removed from any three-pronged plug or serious injury may occur.



SET UP

Unpacking

The **SHOP FOX®** Model W1701 has been carefully packaged for safe transporting. If you notice the machine has been damaged, please contact your authorized **SHOP FOX®** dealer immediately.

If any parts are missing, examine the packaging for the missing parts. For any missing parts, find the part number in the back of this manual and contact Woodstock International, Inc. at (360) 734-3482 or at tech-support@shopfox.biz

Inventory

The following is a description of the main components shipped with the **SHOP FOX®** Model W1701. Lay the components out to inventory them.

Note: Some parts and hardware may already be installed on the machine. make sure to check the machine when you use the inventory list.



CAUTION

LIFTING HAZARD!
Get help lifting and moving the heavy components of this shaper.

SET UP

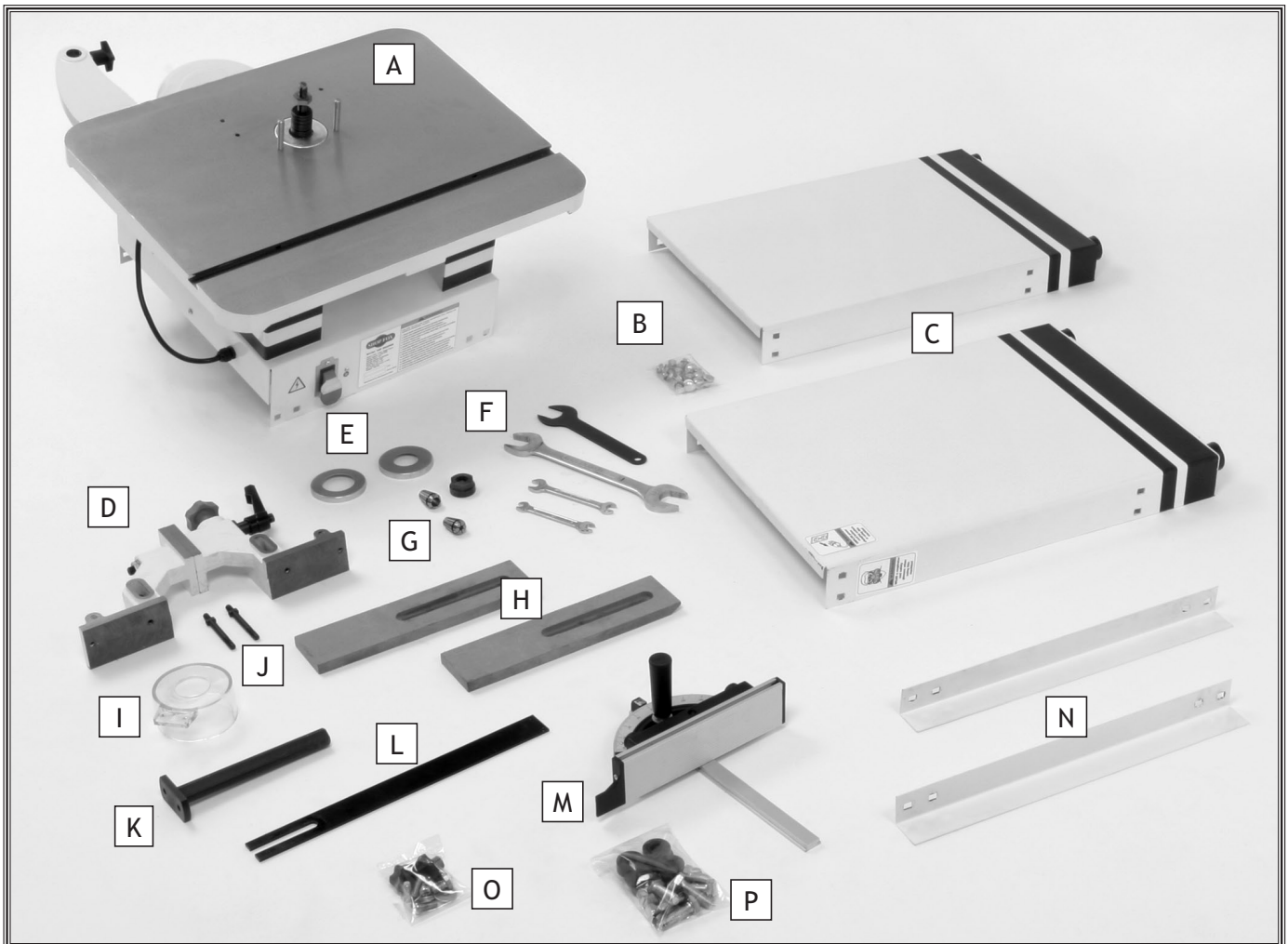

Figure 8. Component layout.

Inventory List

The following is a description of the main components shipped with the **SHOP FOX®** Model W1701. Lay the components out to inventory them, and refer to the list below and **Figure 8**.



Main Contents	Qty
A. Shaper Unit.....	1
B. Stand Bolt Bag	1
– Carriage Bolts ⁵ / ₁₆ "-18 x ¹ / ₂ "	16
– Flat Washers ³ / ₈ ".....	16
– Hex Nuts ⁵ / ₁₆ "-18.....	16
C. Stand Side Panels.....	2
D. Fence Assembly.....	1
E. Table Inserts 1-3/8", 1-3/4"	1
D. Special 26mm Flat Wrench	1
F. Wrenches 8, 14, 23, 26, 30mm	1 Ea
G. Router Bit Collets 1/4", 1/2" & Nut	1 Ea
H. Fence Faces	2
I. Guard.....	1
J. Fence Lock Studs 5/16"-20.....	2
K. Guard Mounting Post.....	1
L. Guard Attachment Bar.....	1
M. Miter Gauge Assembly	1
N. Tie Bars	2
O. Knob and Fence Bolt Bag.....	1
– Star Knobs M8-1.25.....	2
– Large Dia. Flat Washers 8mm	2
– Hex Bolts M8-1.25 x 12	2
– Phillips Head Screws M8-1.25 x 20.....	4
– Flat Washers 8mm.....	6
– Phillips Head Screws M4-.7 x 10	2
– Hex Nuts M4-.7.....	2
P. Table Spacer Kit.....	1
– Hex Bolt M12-1.75 x 30.....	2
– Hex Bolt M12-1.75 x 40.....	5
– Lock Washer 12mm.....	7
– Spacer 1/2"	7

Machine Placement

- **Machine Mobility:** Use the Model D2057 **SHOP FOX®** Heavy-Duty Mobile Base so you can make the most out of your shop space by moving the Model W1701 1HP Shaper out of the way when not in use. Contact your **SHOP FOX®** Dealer for price and availability.
- **Working Clearances:** Consider your current and future shop needs with respect to the machinery and the lumber to be shaped. Allow enough space for safe lumber support as the lumber is fed into the shaper and as it exits the machine.
- **Outlets:** Make sure the electrical circuits have the capacity to handle the amperage requirements for your Model W1701 1HP Shaper. Electrical outlets should be located near the shaper, so power or extension cords are clear of high-traffic areas.

Cleaning Machine

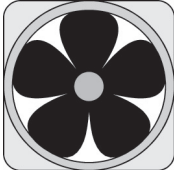
The table and other unpainted parts of your machine type are coated with a waxy grease that protects them from corrosion during shipment. Clean this grease off with a solvent cleaner or citrus-based degreaser. **DO NOT** use chlorine-based solvents such as brake parts cleaner or acetone—if you happen to splash some onto a painted surface, you will ruin the finish.

⚠ CAUTION

ALWAYS work in well-ventilated areas far from possible ignition sources when using solvents to clean machinery. Many solvents are toxic when inhaled or ingested. Use care when disposing of waste rags and towels to be sure they **DO NOT** create fire or environmental hazards.

SET UP

Assembly

	<p>CAUTION LACERATION HAZARD! Inspect edges of all metal parts before handling them. Some metal parts may have sharp edges, which can cause injury.</p>
--	---

To assemble the shaper, do these steps:

1. Lay one stand side on the ground and attach the cross bars with the 8mm carriage bolts, $\frac{3}{8}$ " washers, and 8mm hex nuts as shown in **Figure 9**. DO NOT fully tighten the nuts and bolts at this time.



Figure 9. Attaching cross bars to stand side.

2. Attach the second stand side to the assembly.

Note: At this point, the assembly will be somewhat wobbly. Have an assistant hold the assembly in place while you attach the nuts and bolts.

3. Place the shaper table upside down on two sturdy blocks that are at least $3\frac{1}{2}$ " off the ground as shown in **Figure 10**. Make sure the spindle DOES NOT touch the ground or the weight of the shaper may damage the spindle.



Figure 10. Attaching stand to shaper unit.

4. Place the stand assembly on the shaper and attach it with the 8mm carriage bolts, $\frac{3}{8}$ " washers, and 8mm hex nuts as shown in **Figure 10**.

5. Have an assistant help you turn the shaper unit over.

6. Level the shaper, then tighten all of the assembly bolts on the stand.

NOTE: Sheet steel will often "spring" after it has been fabricated at the factory, occasionally making it difficult to line up precisely with other parts without a bit of effort. Do not be surprised if the stand requires a bit of "persuasion" to fit together. On the other hand, if the parts just do not seem to work together, try switching parts around (such as the tie bars).

7. Using the $\frac{5}{16}$ "-20 x $\frac{3}{4}$ " Phillips head screws, and $\frac{5}{16}$ " washers, install each fence facing to the fence mount brackets as shown in **Figure 11**.

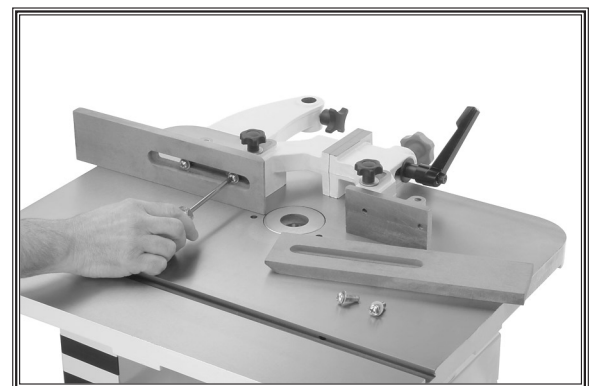

Figure 11. Installing fence facing.

SET UP

8. For custom fence facing, make sure the screw heads are countersunk completely below the surface of the fence face.
9. Connect the safety guard bar to the safety guard shaft with two M8-1.25 x 12 bolts and the 8mm flat washers. See **Figure 12**.
10. Connect the safety guard to the safety guard bar with two M4-0.7 x 12 Phillips® head screws and the M4-0.7 nuts. See **Figure 12**.
11. Position the extension bar and safety guard on the main fence housing and install the T-lock handle. See **Figure 12**.
12. Position the guard as close as possible to the spindle/cutter without impeding the feeding path of the workpiece.
13. Place an 8mm open-end wrench on top the spindle (see **Figure 13**).
14. Using a 14mm open-end wrench on the drawbar nut, (**Figure 14**), make sure the drawbar nut is tight, but **DO NOT** over-tighten the drawbar nut.

Note: *This is an important safety measure that must be done before the **Test Run** on the next page.*

Test Run

Complete this process once you have familiarized yourself with all instructions in this manual.

To test run the shaper, do these steps:

1. Read the entire instruction manual first, so you are familiar with all controls and functions of the shaper!
2. Connect your machine to the power source.
3. Turn the shaper **ON**. The shaper should run smoothly with little or no vibration.
 - Immediately turn the jointer **OFF** if you suspect any problems, and fix those problems before starting the shaper again. If the source of an unusual noise or vibration is not readily apparent, contact our technical support for help at (360) 734-3482 or contact us online at tech-support@shopfox.biz.

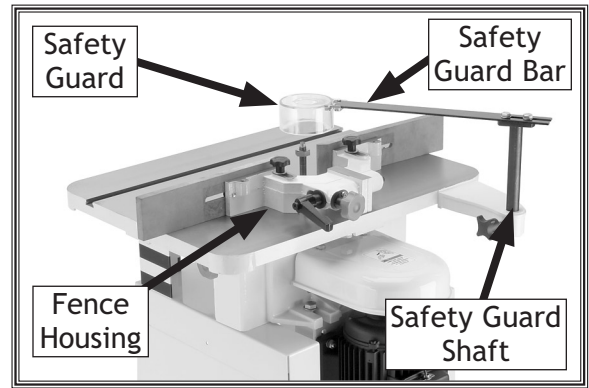

Figure 12. Guard and fence assembly.

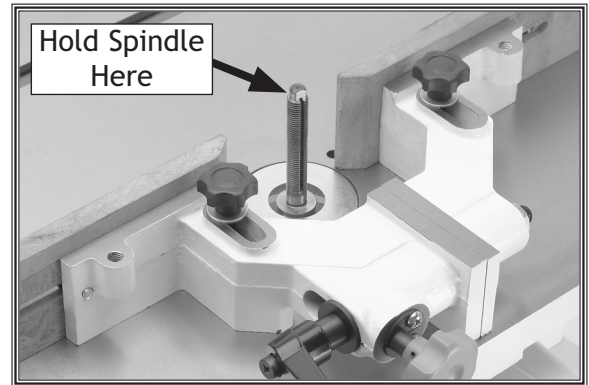

Figure 13. Wrench location on spindle.

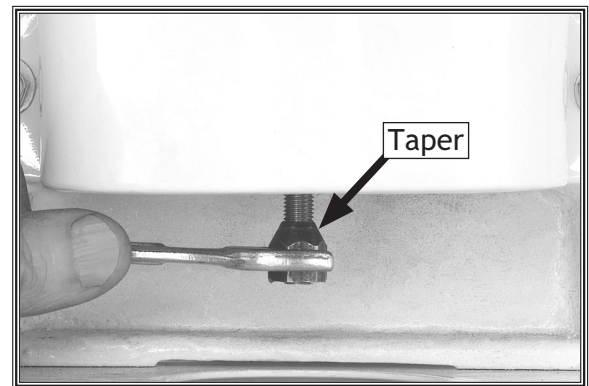

Figure 14. Threading on drawbar nut with the tapered end up.

⚠ WARNING

Projectiles thrown from the machine could cause serious eye injury. Wear safety glasses during the test run!

SET UP

OPERATIONS

General

This machine will perform many types of operations that are beyond the scope of this manual. Many of these operations can be dangerous or deadly if performed incorrectly.

The instructions in this section are written with the understanding that the operator has the necessary knowledge and skills to operate this machine. **If at any time you are experiencing difficulties performing any operation, stop using the machine!**

If you are an inexperienced operator, we strongly recommend that you read books, trade articles, or seek training from an experienced operator before performing any unfamiliar operations. **Above all, your safety should come first!**

Cutters vs. Router Bits

When shipped, the Model W1701 is setup for using shaper cutters. However, if you plan on using router bits, you must first convert the Model W1701 to a router table. To convert your shaper to a router table, refer to **Page 23**.

If you're not sure which type of cutting equipment you will use, read below for the pros and cons of both.

Shaper Cutters

Pros—Shaper cutters are larger, more durable and generally last longer than router bits. If you plan on cutting many linear feet of a certain profile, then shaper cutters are the best choice.

Cons—Shaper cutters are much more expensive than router bits and they are typically too large for small projects.

Router Bits

Pros—Router bits are cheaper than shaper cutters and come in a wider range of profiles and sizes. If you plan on making small projects that do not require many linear feet of cutting, then router bits are the best choice.

Cons—Router bits are not as durable as shaper cutters, and they are typically designed to be operated faster than this machine can operate.

! WARNING



READ and understand this entire instruction manual before using this machine. Serious personal injury may occur if safety and operational information is not understood and followed. DO NOT risk your safety by not reading!

! WARNING



Always wear safety glasses when operating this machine. Failure to comply may result in serious personal injury.

! WARNING

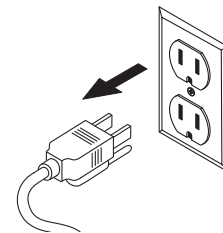

DO NOT investigate problems or adjust the Machine Name while it is running. Wait until the machine is turned OFF, unplugged and all working parts have come to a complete stop before proceeding!

Spindle Elevation

Correct spindle height is crucial to most shaping applications. Use a piece of test wood to confirm the correct spindle height before cutting expensive lumber.

To set the spindle height, do these steps:

1. Loosen the spindle lock knob located on the side of the shaper as shown in **Figure 15**.
2. Move the spindle height lever shown in **Figure 16** to raise the spindle or left to lower the spindle.
3. Retighten the spindle lock knob on the side of the shaper. **DO NOT** over-tighten the knob. Only a small amount of tension is needed to keep the spindle from moving during operation.

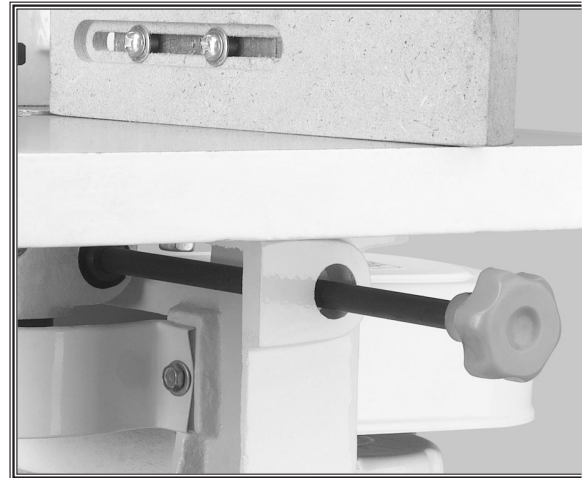

Figure 15. Spindle lock knob.

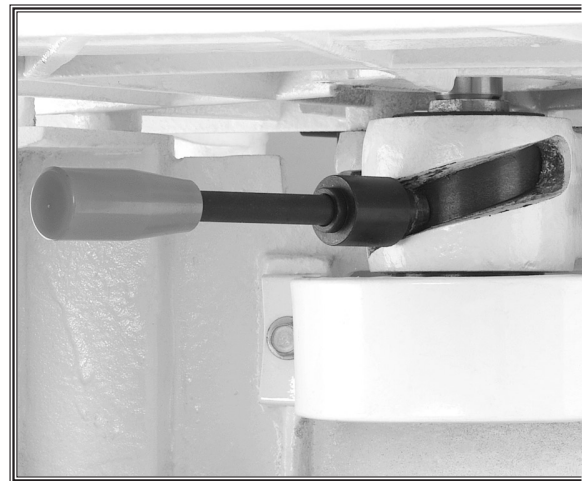

Figure 16. Spindle-height lever.

Spindle Direction

The Model W1701 is capable of operating in two directions by use of the forward and reverse switch shown in **Figure 17**.

It is very important that the workpiece be fed against the direction of the cutter rotation. This will prevent a climb cut and maintains a safe cutting procedure for the operator.

Most operations are done with the switch in the FWD position. However, there will be times when it is necessary to flip the shaper cutter over and run the spindle in the opposite direction (REV).

- When the switch is pointing to the FWD position, the spindle and cutter rotate counterclockwise.
- When pointing to the REV position, the spindle and cutter rotate clockwise.

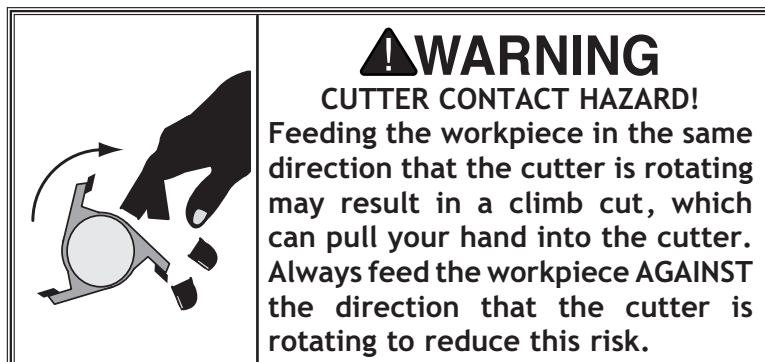
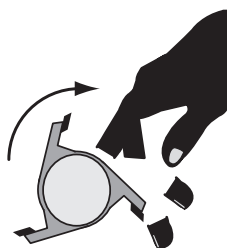

Figure 17. Forward and reverse switch.

⚠ WARNING

CUTTER CONTACT HAZARD!

Feeding the workpiece in the same direction that the cutter is rotating may result in a climb cut, which can pull your hand into the cutter. Always feed the workpiece **AGAINST** the direction that the cutter is rotating to reduce this risk.



Fence Positioning

The two fence faces are independently adjustable to allow for different shaping tasks. The fence faces can be set at different positions to remove material from the entire edge of the wood stock or set at the same position to shape part of the edge.

To adjust the fence, do these steps:

1. Loosen the fence mount lock handle shown in **Figure 18**.
2. Adjust the position of the fence by turning the adjustment knob shown in **Figure 18**.
3. Once the fence is in the desired position, tighten down the fence mount lock handle.

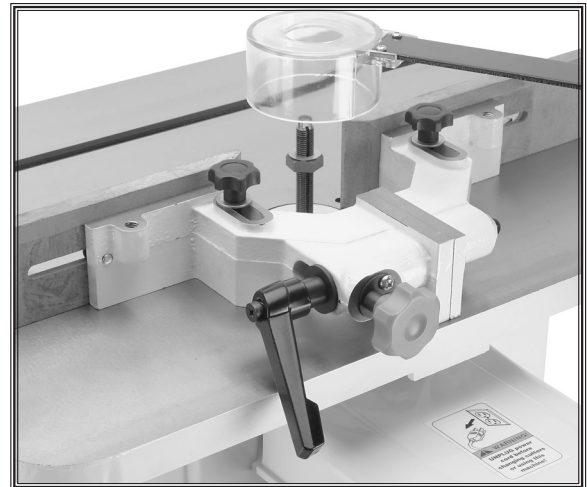

Figure 18. Fence mount lock handle and adjustment knob.

Fence Alignment

Before shaping, check that the two fence faces are parallel.

To align the fences so they are parallel with each other, do these steps:

1. Get a quality straightedge that is long enough to span the entire length of the fence assembly.
2. Adjust the fence faces so they are in as close to the same parallel position as possible.
3. Hold the straightedge across both of the fence faces as shown in **Figure 19**.
4. If the fence faces are not parallel, place shims between the back of the fence face and the face of the fence mount. With some trial and error shim adjusting, parallel fence faces can be achieved.



Figure 19. Use straightedge to check fence.

Table Inserts

Two inserts (**Figure 20**) are provided allowing for three different opening sizes to be achieved. Use the smallest-size opening for a cutter to reduce wood chips falling into the machine. Using the smallest-size opening also covers any unused portion of the bit below the surface of the table, thus reducing the chance of operator injury.

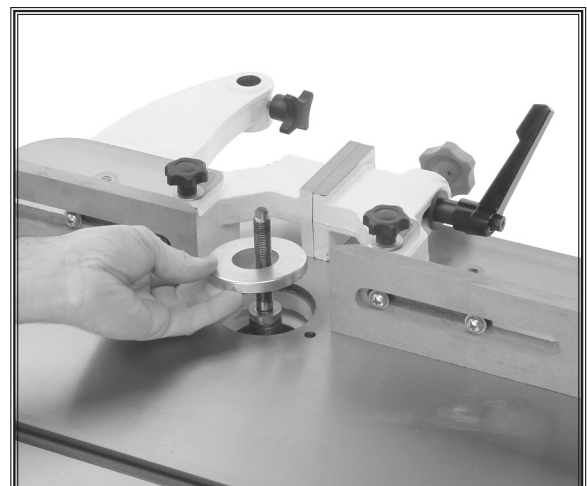
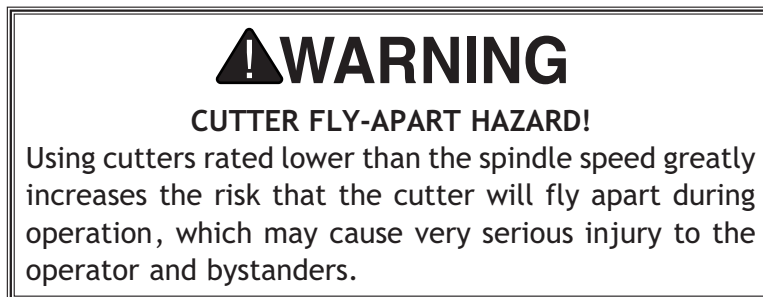
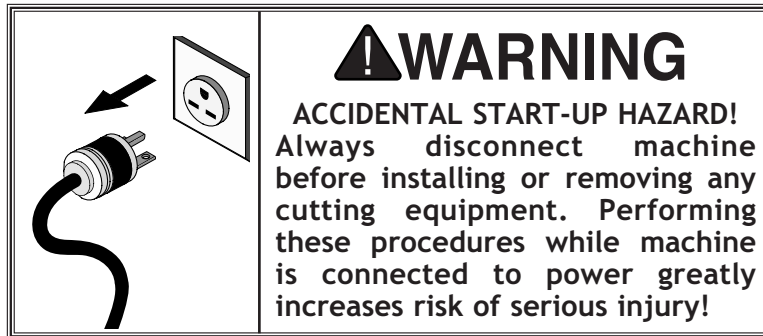

Figure 20. Using table insert to keep wood shavings on the table.

Cutter Installation



Before installing cutters, you must plan the configuration of rub collars and cutters required for the intended application.

Rub collars limit the depth of cut and are typically used with most cutters, depending on the profile and type of cut being performed.

There are three set up positions for rub collars:

- **ABOVE THE CUTTER** as shown in **Figure 21**. This setup is the safest and produces the most consistent results.
- **BETWEEN TWO CUTTERS** as shown in **Figure 22**. This setup has the advantage of making two profile cuts in a single pass.
- **BELOW THE CUTTER** as shown in **Figure 23**. This setup allows the cut to be viewed by the operator; however, it is also the most dangerous because the operator is exposed to the moving cutter.

WE DO NOT RECOMMEND SHAPING WITH A RUB COLLAR BELOW THE CUTTER!

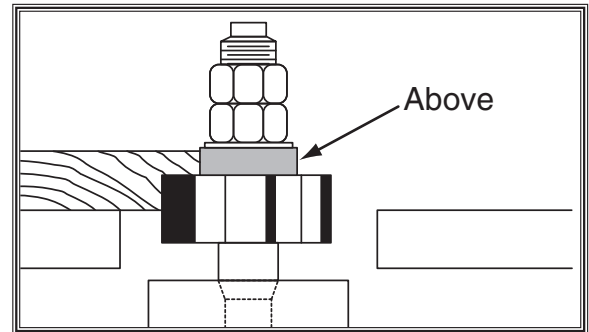

Figure 21. Rub collar mounted above cutter.

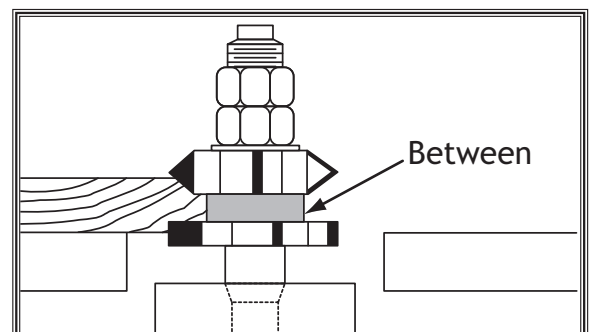

Figure 22. Rub collar mounted between two cutters.

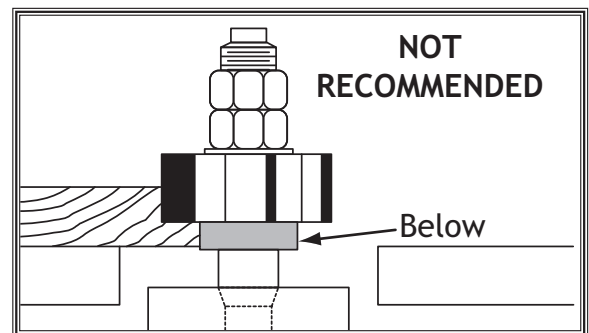

Figure 23. Rub collar mounted below cutter.

To install cutters and rub collars, do these steps:

1. DISCONNECT SHAPER FROM POWER SOURCE!
2. Slide the cutter(s) and rub collars onto the spindle in the correct orientation for your intended cut.
3. Install the keyed safety washer and nut as shown in Figure 24.

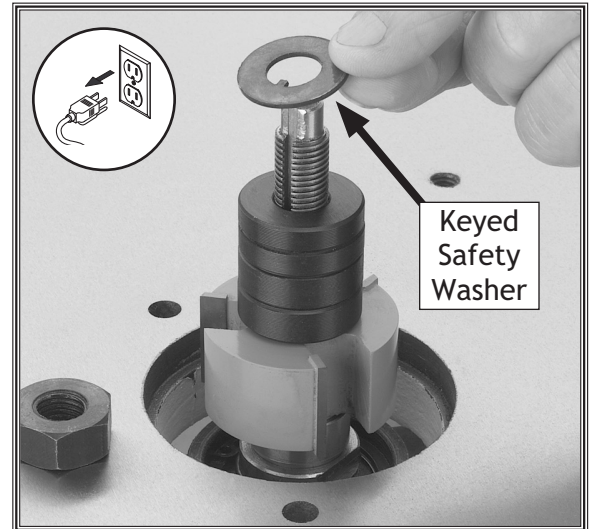

Figure 24. Placing the keyed safety washer.

4. Thread on and tighten down the spindle nut with the provided 23mm wrench, while holding the spindle at the top with an 8mm wrench, as shown in Figure 25.
5. Make sure the cutter rotates freely in the correct direction needed for the cut (in most cases this is the FWD direction on the FWD/REV switch, which is counterclockwise on the spindle).
6. Install applicable safety guard(s).



Figure 25. Tightening spindle nut.

! WARNING

CUTTER FLY-APART HAZARD!

Always use the keyed safety washer! The lock tang on this washer prevents the shaper cutter bit from loosening the spindle nut during operation.



! DANGER

AMPUTATION/LACERATION HAZARD!

Accidental contact with a cutter during operation will remove parts of fingers or large chunks of flesh. Safety guards greatly reduce this risk and must always be used when operating this machine!

OPERATIONS

Router Bit Installation

Before using router bits, you should convert the shaper to a router table. Refer to **Table Spacer Kit** on **Page 23** to learn how to do this.

The Model W1701 comes with a 1/2" and 1/4" router bit collet. When installing router bits, make sure that the router bits are secure before starting the machine. A loose router bit may fly out of the spindle.

To install the router bit collet, do these steps:

1. DISCONNECT SHAPER FROM POWER SOURCE!
2. Push the collet into the collet nut until the off-center lip of the collet nut snaps into the collet groove. See **Figure 26**.

Note: *This lip and groove pulls the collet from the spindle when the collet nut is removed.*

3. Place the collet nut and collet into the spindle. See **Figure 27**.
4. Finger tighten the collet nut onto the spindle until it is flush with the top of the collet nut.
5. Insert the router bit.
6. Using the 26mm special flat wrench, insert it under the table and hold the spindle stationary (see **Figure 28-A**) while using the 30mm wrench to tighten the collet securing the router bit (see **Figure 28-B**).

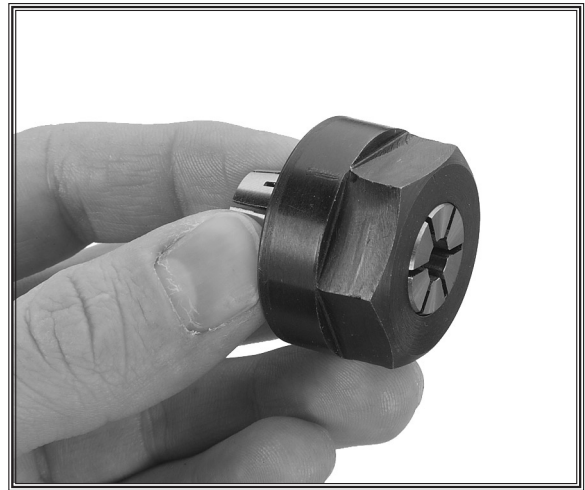

Figure 26. Router bit collet in collet nut.

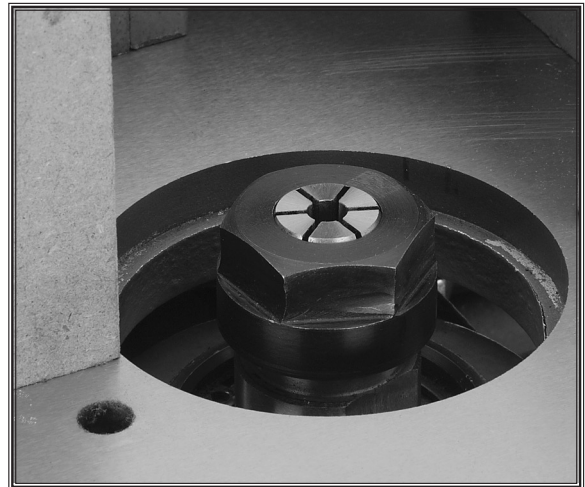

Figure 27. Installed collet flush with top of collet nut.

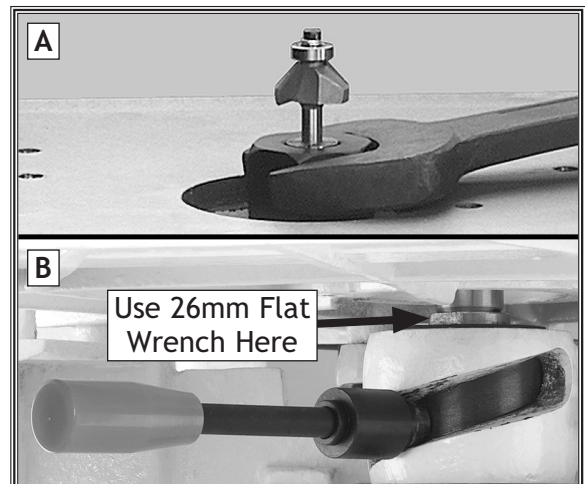

Figure 28. Installing a router bit.

Straight Shaping

Because the shaper fence is independently adjustable, you can set up the shaper to cut part or all of the workpiece edge.

To set the fence up for cutting material from the whole edge of the workpiece, do these steps:

1. Loosen the locking handle shown in **Figure 29**.
2. Turn the adjustment knob located on the back of the fence mount and adjust the infeed fence until the workpiece contacts the cutter at the desired location.
3. Tighten the lock handle to lock the fence into position.
4. Adjust the outfeed fence so that it is located as far back from the front of the table as possible.
5. Turn the shaper *ON*.
6. Using a piece of scrap wood, advance the workpiece 8" into the cutters, and turn the machine *OFF*. **DO NOT** remove the workpiece from the infeed fence face.
7. Once the cutter has come to a complete stop, adjust the outfeed fence so that it just touches the newly cut edge as shown in **Figure 30**.
8. Make sure all fence lock handles are tight.

To set up the fence for partial edge removal, do these steps:

1. Loosen the lock handle on the side of the fence mount.
2. Turn the adjustment knob and adjust the infeed fence until the workpiece contacts the cutter at the desired location.
3. Tighten the lock handle to lock the fence into position.
4. Adjust the outfeed fence so that it comes into alignment with the infeed fence as shown in **Figure 31**.

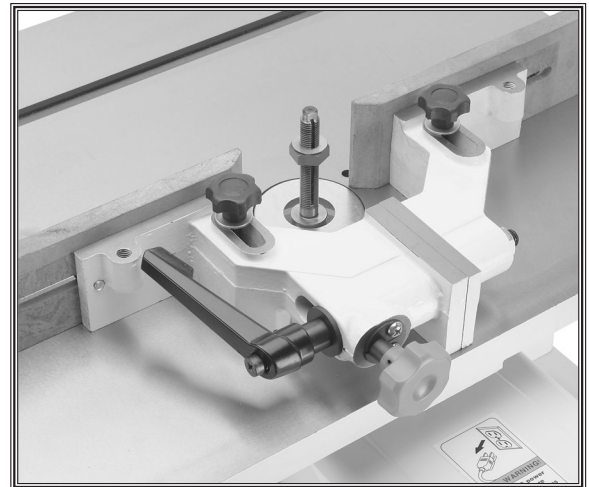

Figure 29. Fence controls.

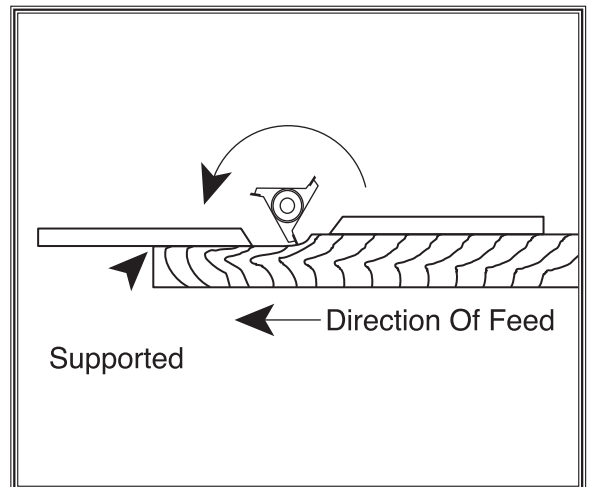

Figure 30. Fence setup for jointing-type operations (Guard Not Shown For Clarity).

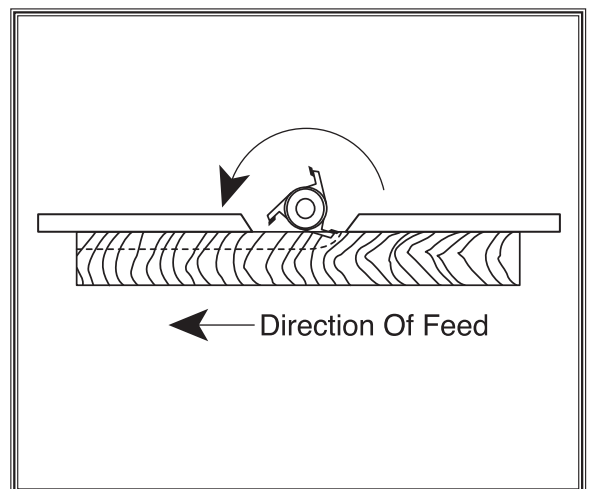

Figure 31. Fence setup for partial-edge removal (Guard Removed For Clarity).

- Now place a straightedge against both faces of the fence to check alignment. Once they are both in alignment, make sure the lock handle is tightened.

Always feed the wood against the rotation of the cutter as shown in **Figure 32**. Another way to conceptualize this is to always feed the wood into the cutter so that the cutter is pushing against the direction of feed. Never feed wood in the same direction as the cutter rotation. This is called a "climb cut" and is extremely dangerous.

Also, examine the grain on the side edge of the board. Whenever possible, run the board so the shaper cutters are cutting with the grain as shown in **Figure 31**. This will minimize the chance of tear out.

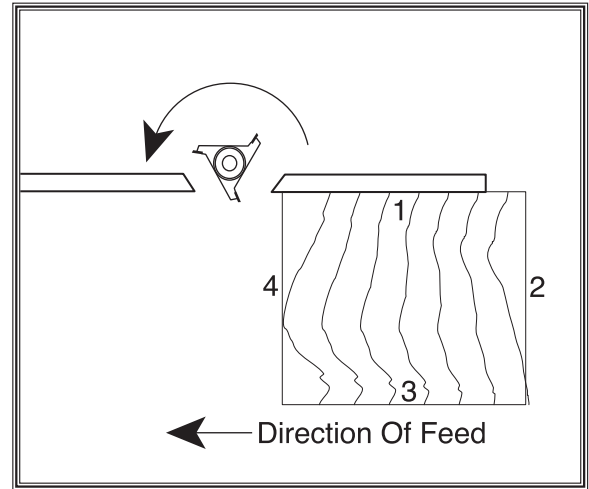

Figure 32. Sequence for shaping an edge around a workpiece (Guard Removed For Clarity).

	<p>⚠ WARNING CUTTER CONTACT HAZARD! Cutting small or narrow workpieces greatly increases the risk of cutter contact during operation. Use jigs or holding devices when cutting to reduce this risk.</p>
--	---

Templates

The use of templates allows identical parts to be cut with speed and accuracy. Shaping with a pattern begins by attaching a prefabricated template to the rough workpiece. The edge of the template rides against a rub collar on the spindle as the cutter cuts the matching profile on the workpiece edge as shown in **Figure 33**.

Template Construction Tips:

- Make sure that screws or clamps will not come into contact with the cutter.
- Design the assembly so that cutting will occur underneath the workpiece.
- Make handles for safety and control.
- Use materials that will move easily across the table surface and rub collar.
- Install hold-down clamps at three sides of the pattern assembly or screw the pattern assembly to the back side of the workpiece.

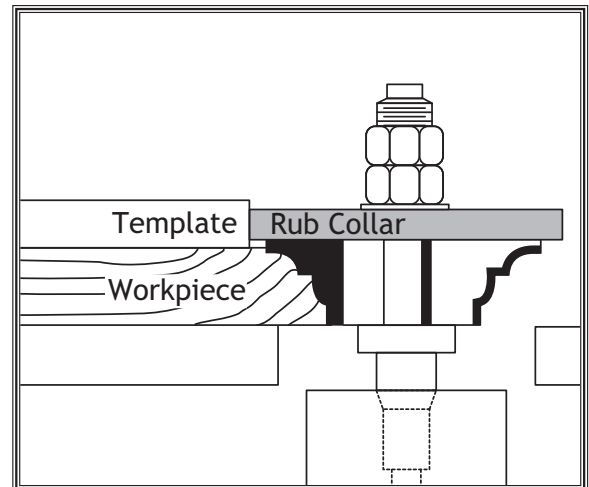

Figure 33. Profile of a template being used.

Freehand Shaping

Freehand shaping is shaping without the aid of the miter slot or fence. The most dangerous part of shaping free-hand is beginning the cut, where the cutter first contacts the workpiece. Often the workpiece will tend to jerk or kickback, catching the operator off guard.

To reduce kickbacks and maintain workpiece control when freehand shaping, use a starting pin or starting block. The pin/block allows you to maintain workpiece control by anchoring and slowly pivoting the workpiece into the cutter as the cut is started (see **Figure 34**).

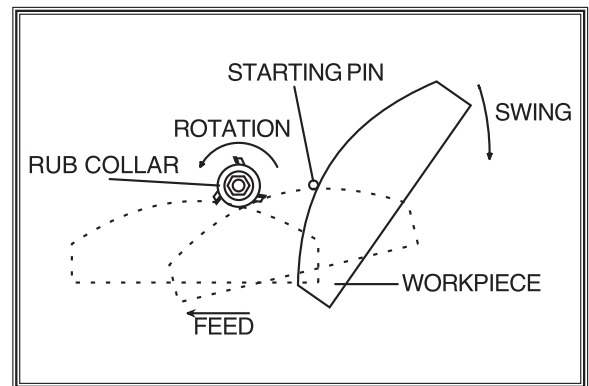

Figure 34. Starting pin operation (Guard not shown for clarity).

⚠ WARNING

Freehand shaping often requires you to remove the fence resulting in reduced protection from the cutters. **ALWAYS** use an auxiliary jig and take extreme care when shaping with the fence removed.

To set up the shaper for freehand shaping, do these steps:

1. DISCONNECT SHAPER FROM POWER SOURCE!
2. Remove the fence assembly from the shaper.
3. Insert the starting pin in the best suited hole on the table so you can feed the workpiece into and against the rotation of the cutter.
4. Install the cutter so it will cut in the correct direction, and adjust the spindle height.
5. Install the safety guard. **DO NOT** use the shaper without a guard.
6. Use a supplemental hold-down jig like the **SHOP FOX® W1500 Right Angle Jig** shown in the **Accessories** section, or you can use rubberized-handle push blocks to support or guide the workpiece and protect your hands.
7. Place the workpiece against the starting pin.
8. Slowly pivot and feed the workpiece into the cutter. Avoid starting the cut on the corner of the workpiece as kickback could occur. Once the cut is started, the workpiece should be pulled away from the starting pin.

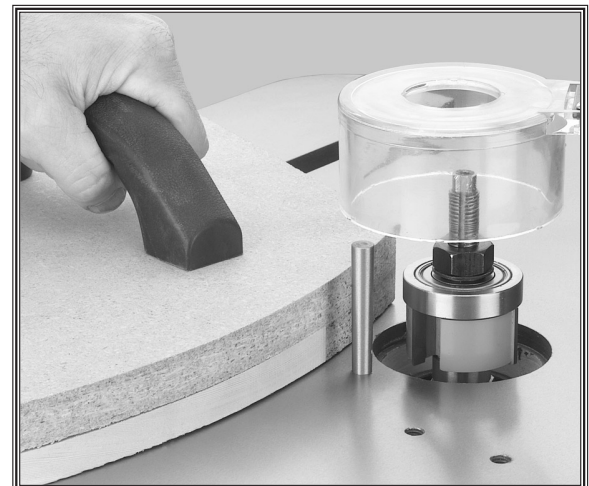

Figure 35. Hold-down jig used to support workpiece.



Figure 36. A piece of wood clamped to the table can serve as a starting block. (Guard not shown for clarity).

MAINTENANCE

General

Regular periodic maintenance on your Model W1701 1HP Shaper will ensure its optimum performance. Make a habit of inspecting your shaper each time you use it

Check for the following conditions and repair or replace when necessary:

- Loose mounting bolts.
- Worn switch.
- Worn or damaged cords and plugs.
- Damaged drive belt.
- Any other condition that could hamper the safe operation of this machine.

Table & Base

Cleaning the Model W1701 is relatively easy. Vacuum excess wood chips and sawdust, and wipe off the remaining dust with a dry cloth. If any resin has built up, use a resin dissolving cleaner to remove it.

Protect the unpainted cast iron surfaces on the table by wiping the table clean after every use—this ensures moisture from wood dust does not remain on bare metal surfaces.

Keep tables rust-free with regular applications of a quality metal protectant.

Lubrication

Since all bearings are shielded and permanently lubricated, simply leave them alone until they need to be replaced. Do not lubricate them.

For other items on this machine, an occasional application of light machine oil is all that is necessary. Before applying lubricant, clean off sawdust.

Your goal is to achieve adequate lubrication. Too much lubrication will attract dirt and sawdust. Various parts of your machine could lose their freedom of movement as a result.

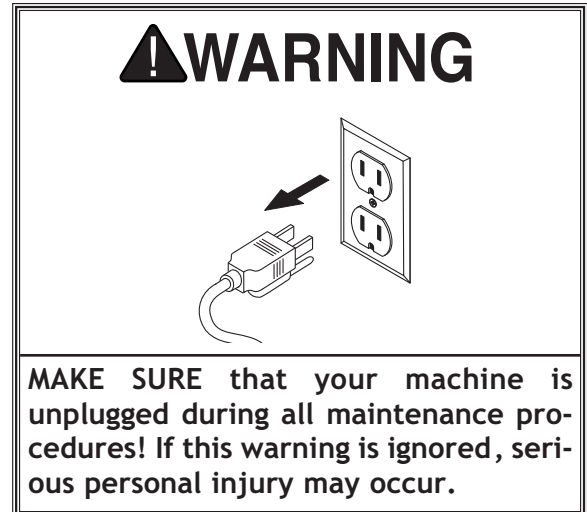

Maintenance Schedule

Daily:

- Vacuum all dust on and around the machine.
- Wipe down tables and all other unpainted cast iron with a metal protectant.

Every Month:

- V-belt tension, damage, or wear.
- Clean/vacuum dust buildup from inside cabinet and off of motor.

SERVICE

General

This section covers the most common service adjustments or procedures that may need to be made during the life of your machine.

If you require additional machine service not included in this section, please contact Woodstock International Technical Support at (360) 734-3482 or send e-mail to: tech-support@shopfox.biz.

Belt Adjustment

Your shaper uses a flat-type belt on two drum-style pulleys, to compensate for different belt positions as the spindle height is adjusted.

To adjust belt, do these steps:

1. DISCONNECT SHAPER FROM POWER SOURCE!
2. Loosen the belt adjustment bolts as shown in **Figure 37**.
3. Slide the motor position to increase or decrease belt tension, so the belt is snug with about 1/4" deflection when pressed lightly with your fingertips.
4. Tighten the belt adjustment bolts.

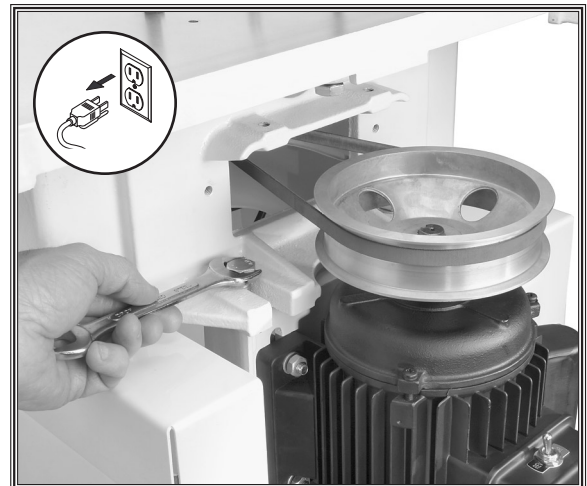
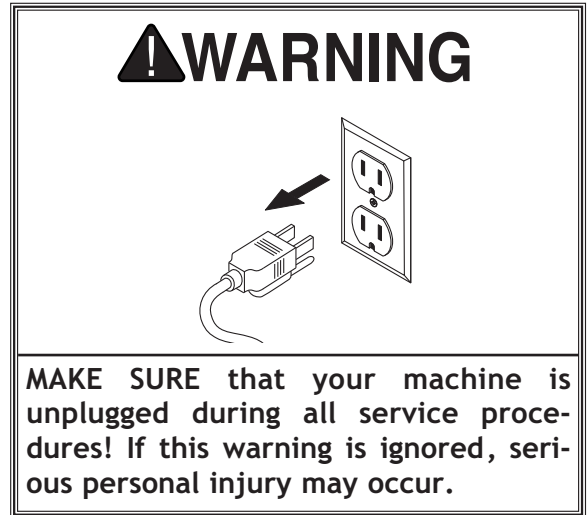

Figure 37. Adjusting belt tension.

Table Spacer Kit

The provided table spacer kit allows you to modify your shaper for use as a router table by raising the table. A higher table will allow you to make shallow cuts and utilize the upper blade area of most router bits with standard-length shanks.

To install the table spacer kit, do these steps:

1. DISCONNECT SHAPER FROM POWER SOURCE!
2. Remove the spindle lock nut and any cutters or rub collars installed on the spindle.
3. Remove table from the shaper by undoing the seven bolts that secure it in place.
4. Loosen and remove the taper nut (see **Figure 38**) while holding the top of the spindle with a wrench.
5. Gently tap the bottom of the drawbar to knock the spindle loose.
6. Remove the spindle/drawbar assembly from the spindle cartridge.
7. Place the table spacers over the table mounting holes on the shaper.
8. Place the table on the spacers and secure it to the shaper with the hex bolts from the router table spacer kit (see **Figure 39**).
9. Save the removed table bolts for when you need to convert the Model W1701 back to use as a shaper.
10. Refer to Router Bit Installation on **Page 17** for instructions on installing the collets and router bits.

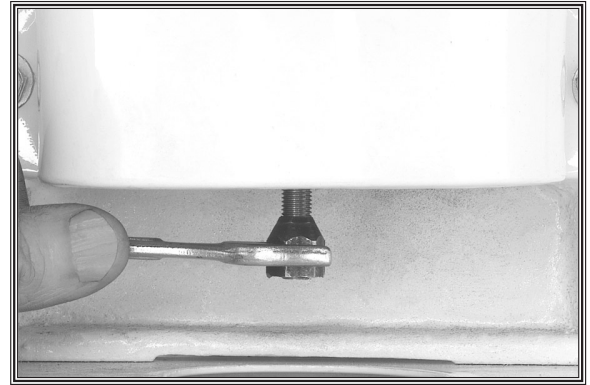

Figure 38. Removing taper nut from drawbar.

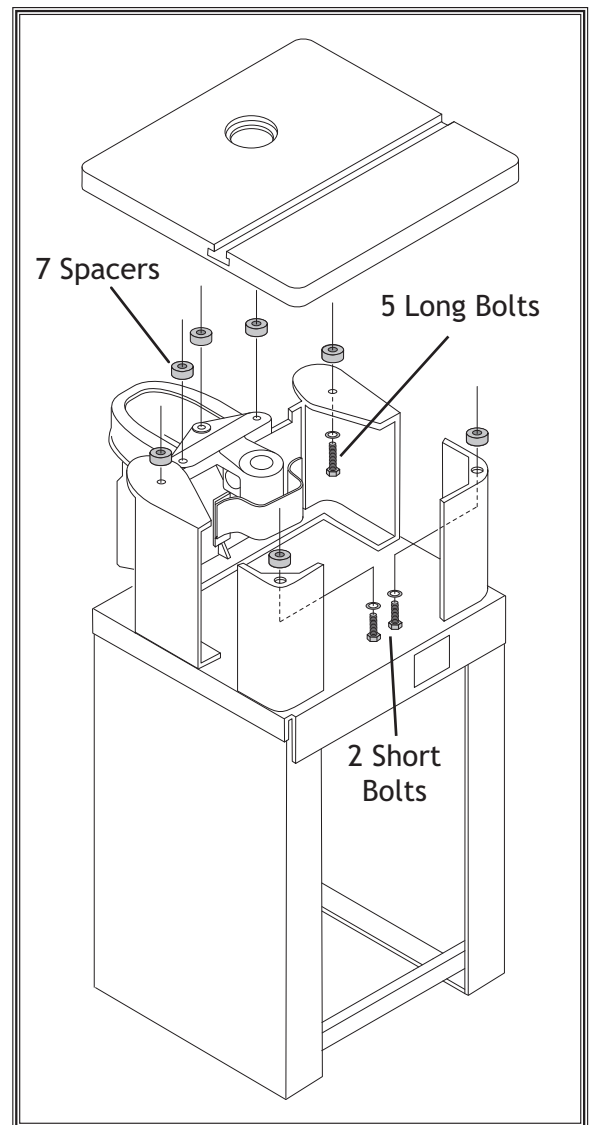

Figure 39. Installing table spacers.

Spindle Cartridge Replacement

Should a bearing fail, your shaper will probably develop a noticeable rumble, which will increase when the machine is put under load. If allowed to get worse, overheating of the journal containing the bad bearing could occur, which may cause the bearing to seize and possibly damage other parts of the machine.

Rather than disassemble the spindle cartridge to remove worn out bearings, Woodstock International offers replacement spindle cartridge assemblies (Part# X1701407) as whole units, which makes replacement very simple. The procedure takes 15-20 minutes.

To replace the spindle cartridge assembly:

1. DISCONNECT SHAPER FROM POWER SOURCE!
2. Remove the spindle and drawbar from the spindle cartridge assembly. (Remove tapered drawbar nut and tap the drawbar up to knock it loose.)
3. Take off the spindle pulley cover by removing the two mounting bolts shown in **Figure 40**.
4. Loosen the two motor mount bolts, slide the motor forward, and remove the V-belt.
5. Loosen the spindle lock knob.
6. Remove the cartridge nut on the bottom of the spindle, as shown in **Figure 41**, and slide the pulley off.
7. Hold your hand under the spindle cartridge and remove the elevation handle by unthreading it counterclockwise. The spindle cartridge should drop into your hand.
8. Install the new cartridge assembly in the reverse order of removal.

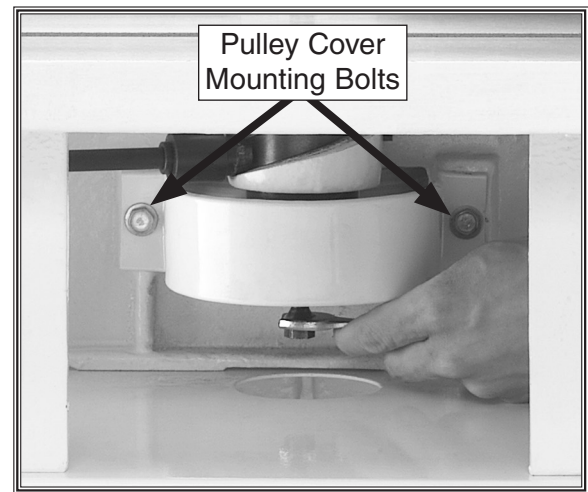

Figure 40. Location of pulley cover mounting bolts.

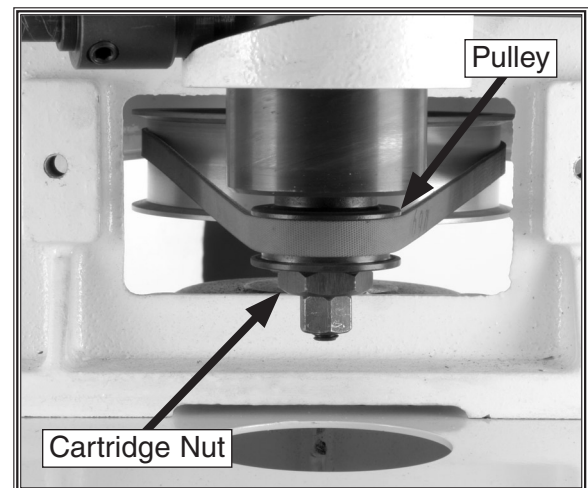

Figure 41. Location of cartridge nut and pulley.

Resurfacing Fence

The fence can be resurfaced or made flat with a jointer to correct any warping. This procedure should only be done if the fences will not align with each other after careful adjustment or they are warped.

To resurface the fence, do these steps:

1. Make sure the fence face mounting screws are far enough below the surface of the fence that they will not contact the jointer knives during operation.

Note: *New fence faces can easily be made out of hard wood and resurfaced by using this same procedure.*

2. Align both fence faces as straight as possible, using a straightedge or your jointer table as an alignment guide.
3. Resurface the fences on the jointer, as shown in **Figure 42**.

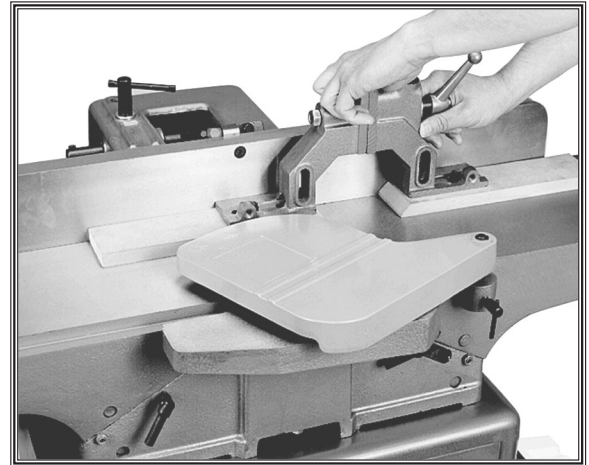
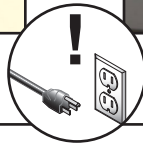
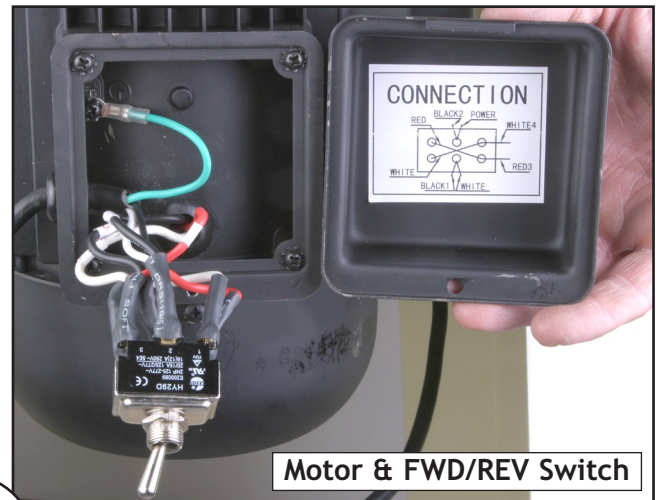
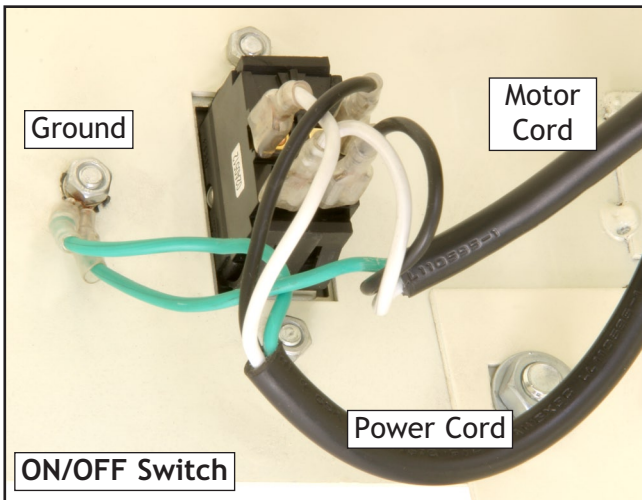

Figure 42. Resurfacing a shaper fence on a jointer.

Electrical Components & Wiring



MODEL W1701

⚠ DANGER
Disconnect power before performing any electrical service. Electricity presents serious shock hazards that will result in severe personal injury and even death!

COLOR KEY	
BLACK	
WHITE	
GREEN	
RED	

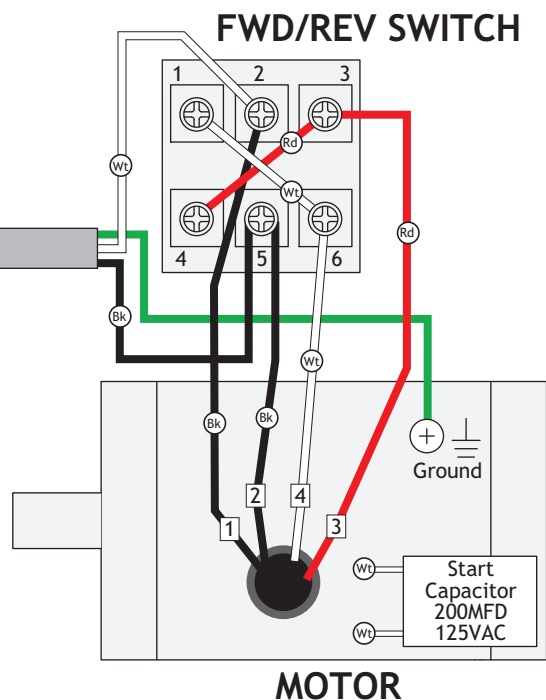
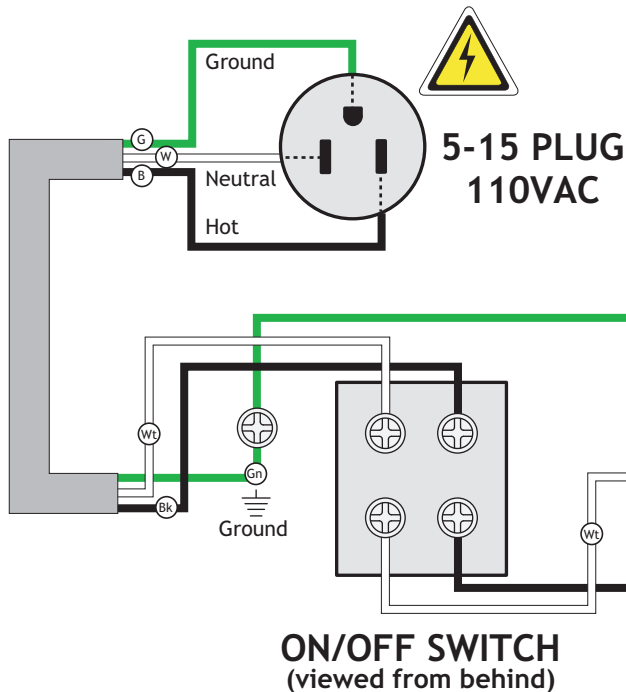

SERVICE

PARTS

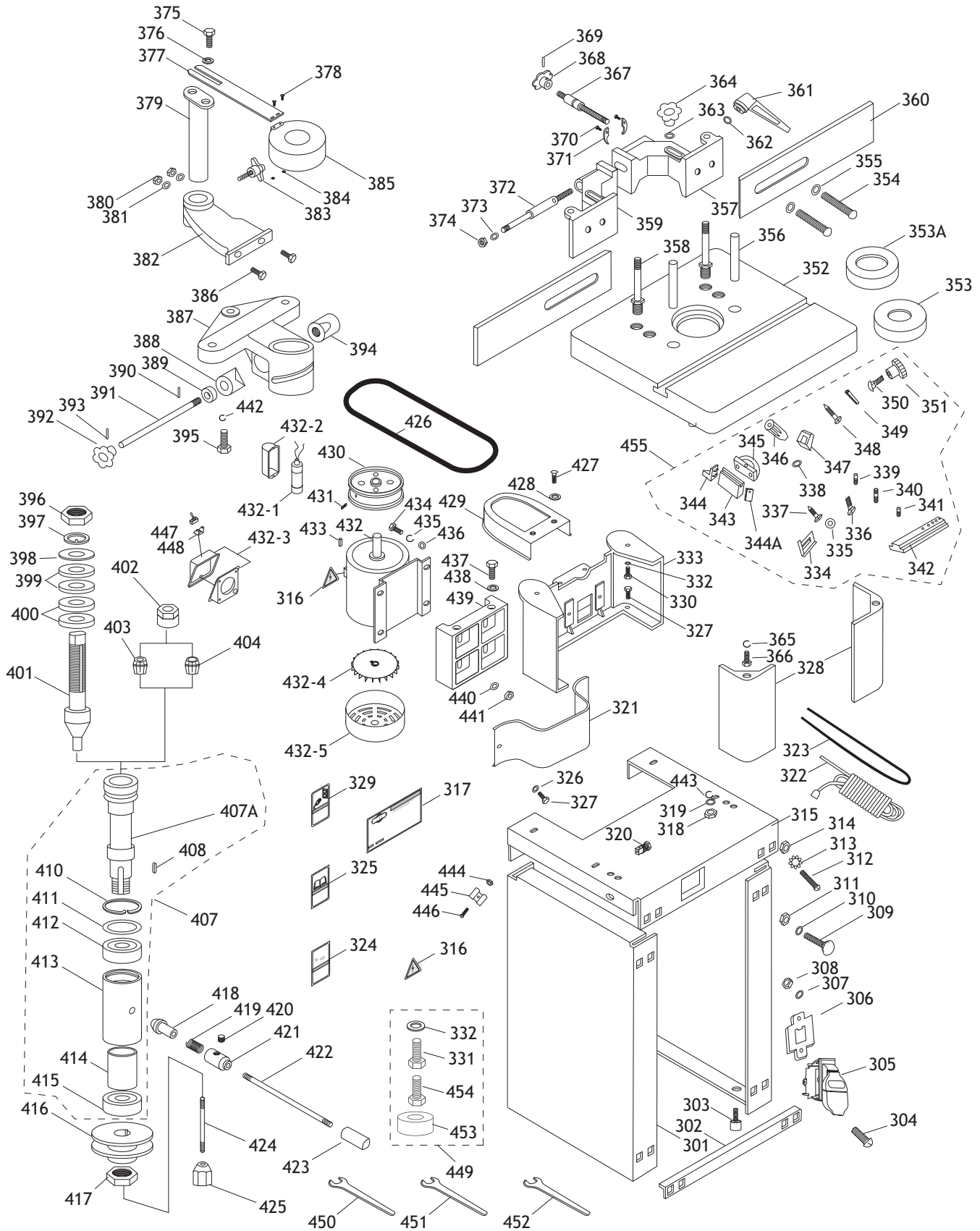

Parts List

REF	PART #	DESCRIPTION
301	X1701301	SIDE PANEL
302	X1701302	TIE BAR
303	X1701303	RUBBER FOOT
304	XPS18M	PHLP HD SCR M4-0.7 X 25
305	XPSW09	ON/OFF PADDLE SWITCH
306	X1701306	SWITCH LAMELLA
307	XPW05M	FLAT WASHER 4MM
308	XPNO4M	HEX NUT M4-0.7
309	XPCB02	CARRIAGE BOLT 5/16-18 x 1/2
310	XPW02	FLAT WASHER 3/8
311	XPNO2	HEX NUT 5/16-18
312	XPS08M	PHLP HD SCR M5-0.8 X 12
313	XPTLW02M	EXT TOOTH WASHER 5MM
314	XPNO6M	HEX NUT M5-0.8
315	X1701315	SHELF
316	X1701316	ELECTRICITY LABEL
317	X1701317	ID / WARNING LABEL
318	XPNO3M	HEX NUT M8-1.25
319	XPW02	FLAT WASHER 3/8"
320	X1701320	STRAIN RELIEF
321	X1701321	SPINDLE PULLEY GUARD
322	XPWRCD110L	POWER CORD W/PLUG
323	XPWRCD110S	MOTOR CORD
324	X1701324	SAFETY GLASSES LABEL
325	X1701325	READ MANUAL LABEL
326	XPW02	FLAT WASHER 3/8"
327	XPB06M	HEX BOLT M8-1.25 X 12
328	X1701328	TABLE LEG
329	X1701329	UNPLUG MACHINE LABEL
330	XPB07M	HEX BOLT M8-1.25 X 25
331	XPB27M	HEX BOLT M12-1.75 X 30
332	XPLW05M	LOCK WASHER 12MM
333	X1701333	TABLE SUPPORT
334	X1701334	MITER BLOCK
335	XPW06	FLAT WASHER 1/4"
336	XPS17M	PHLP HD SCR M4-0.7 X 6
337	XPHTEK13M	TAP SCREW M3.5 X 12
338	XPW02	FLAT WASHER 3/8"
339	X1701339	SUPPORT POLE
340	X1701340	STUD BOLT
341	X1701341	ANTI-KICKBACK PIN
342	X1701342	MITER BAR
343	X1701343	ALUMINUM ALLOY FENCE
344	X1701344	RIGHT FENCE LID
344A	X1701344A	LEFT FENCE LID
345	X1701345	MITER GAUGE BODY
346	X1701346	PLASTIC HANDLE
347	X1701347	POINTER
348	XPHTEK9M	SELF TAP SCREW M3 X 15
349	X1701349	TENSION PIN 2 X 16MM
350	XPCB04M	CARRIAGE BOLT M6-1 X 35

REF	PART #	DESCRIPTION
351	X1701351	KNOB FEMALE M6-1.0
352	X1701352	WORKING TABLE
353	X1701353	TABLE INSERT 13/8" HOLE
353A	X1701353A	TABLE INSERT 13/4" HOLE
354	XPS04M	PHLP HD SCR M8-1.25 X 20
355	XPW02	FLAT WASHER 3/8"
356	X1701356	TAPER PIN 8 X 75MM
357	X1701357	FENCE BODY RIGHT
358	X1701358	CLAMP STUD
359	X1701359	FENCE BODY LEFT
360	X1701360	WOODEN FENCE
361	X1701361	LOCK HANDLE M12-1.75
362	XPW01	FLAT WASHER 1/2"
363	XPW02	FLAT WASHER 3/8"
364	X1701364	KNOB M8-1.25 FEMALE
365	XPLW07	LOCK WASHER 1/2"
366	XPB49M	HEX BOLT M12-1.75 X 20
367	X1701367	ADJUSTING SCREW STUD
368	X1701368	HAND KNOB 8MM PINNED
369	XPRP42M	ROLL PIN 3 X 20
370	XPS14M	PHLP HD SCREW M6-1 X 12
371	X1701371	HALF COLLAR
372	X1701372	ADJUSTING SHAFT
373	XPW01	FLAT WASHER 1/2"
374	XPNO9M	HEX NUT M12-1.75
375	XPB06M	HEX BOLT M8-1.25 X 12
376	XPW02	FLAT WASHER 3/8"
377	X1701377	HOLD DOWN BAR
378	XPS38M	PHLP HD SCR M4-0.7 X 10
379	X1701379	GUARD MOUNTING POST
380	XPNO3M	HEX NUT M8-1.25
381	XPW02	FLAT WASHER 3/8"
382	X1701382	MOUNTING BRACKET
383	X1701383	HAND KNOB M10-1.5 X 28
384	XPNO4M	HEX NUT M4-0.7
385	X1701385	SAFETY GUARD
386	XPB20M	HEX BOLT M8-1.25 X 30
387	X1701387	HOUSING BRACKET
388	X1701388	CLAMP SLEEVE LEFT
389	X1701389	STUFF RING
390	XPRP42M	ROLL PIN 3 X 20MM
391	X1701391	LOCK BAR
392	X1701392	HAND KNOB 12MM, PINNED
393	XPRP42M	ROLL PIN 3 X 20MM
394	X1701394	CLAMP SLEEVE RIGHT
395	XPB26M	HEX BOLT M12-1.75 X 30
396	X1701396	SPECIAL SPINDLE NUT
397	X1701397	KEYED SAFETY WASHER
398	X1701398	RUB COLLAR 1/2" X 1-3/16" X 3/16"
399	X1701399	RUB COLLAR 1/2" X 13/16" X 1/4"

Continued on next page 

REF	PART #	DESCRIPTION
400	X1701400	RUB COLLAR 1/2" X 13/16" X 3/8"
401	X1701401	CUTTER SPINDLE
402	X1701402	COLLET NUT
403	X1701403	COLLET 1/4"
404	X1701404	COLLET 1/2"
405	X1701405	COLLET
407	X1701407	SPINDLE CARTRIDGE ASSY
407A	X1701407A	SPINDLE CARTRIDGE
408	XP48M	KEY 4 X 4 X 20MM
409	X1701409	CLAMP RING
410	XPR25M	INT RETAINING RING 47MM
411	X1701411	WAVY WASHER 45MM
412	XP6204	BALL BEARING 6204
413	X1701413	SPINDLE HOUSING
414	X1701414	BALL BEARING SLEEVE
415	XP6204	BALL BEARING 6204
416	X1701416	SPINDLE PULLEY
417	X1701417	LOWER SPINDLE NUT
418	X1701418	BEARING CONE
419	X1701419	COIL SPRING
420	XPSS20M	SET SCREW M8-1.25 X 8
421	X1701421	SPRING COLLAR
422	X1701422	STUD M12-1.75 X 355
423	X1701423	SLIP-ON HANDLE
424	X1701424	DRAW BAR M8-1.0 X 130
425	X1701425	TAPER NUT M8-1.25
426	X1701426	FLAT BELT 690 X 10MM
427	XPB06M	HEX BOLT M8-1.25 X 12
428	XPW02	FLAT WASHER 3/8"
429	X1701429	BELT GUARD
430	X1701430	MOTOR PULLEY

REF	PART #	DESCRIPTION
431	XPSS01M	SET SCREW M6-1 X 10
432	X1701432	MOTOR
432-1	XPC300S	S. CAPACITOR 200MFD 125VAC
432-2	X1701432-2	CAPACITOR COVER
432-3	X1701432-3	WIRING BOX
432-4	X1701432-4	MOTOR FAN
432-5	X1701432-5	MOTOR FAN COVER
433	XP48M	KEY 5 X 5 X 22MM
434	XPB20M	HEX BOLT M8-1.25 X 35
435	XPLW04M	LOCK WASHER 8MM
436	XPW02	FLAT WASHER 3/8"
437	XPB75M	HEX BOLT M12-1.75 X 35
438	XPW01	FLAT WASHER 1/2"
439	X1701439	MOTOR MOUNT PLATE
440	XPW02	FLAT WASHER 3/8"
441	XP48M	HEX NUT M8-1.25
442	XPLW05M	LOCK WASHER 12MM
443	XPLW04M	LOCK WASHER 8MM
444	XPW06	FLAT WASHER 1/4"
445	X1701445	TWO CORD CLAMP
446	XP48M	PHLP HD SCR M6-1 X 12
447	X1701447	FWD/REV SWITCH
448	X1701448	SWITCH BRACKET
449	X1701449	TABLE SPACER KIT
450	X1701450	FLAT WRENCH 23MM
451	X1701451	FLAT WRENCH 26MM
452	X1701452	FLAT WRENCH 30MM
453	X1701453	RUB COLLAR 1/2" X 13/16" X 1/2"
454	X1701454	HEX BOLT M12-1.75 X 40
455	X1701455	MITER GAUGE ASSEMBLY

Warranty

Woodstock International, Inc. warrants all **SHOP FOX**[®] machinery to be free of defects from workmanship and materials for a period of two years from the date of original purchase by the original owner. This warranty does not apply to defects due directly or indirectly to misuse, abuse, negligence or accidents, lack of maintenance, or reimbursement of third party expenses incurred.

Woodstock International, Inc. will repair or replace, at its expense and at its option, the **SHOP FOX**[®] machine or machine part which in normal use has proven to be defective, provided that the original owner returns the product prepaid to the **SHOP FOX**[®] factory service center or authorized repair facility designated by our Bellingham, WA office, with proof of their purchase of the product within two years, and provides Woodstock International, Inc. reasonable opportunity to verify the alleged defect through inspection. If it is determined there is no defect, or that the defect resulted from causes not within the scope of Woodstock International Inc.'s warranty, then the original owner must bear the cost of storing and returning the product.

This is Woodstock International, Inc.'s sole written warranty and any and all warranties that may be implied by law, including any merchantability or fitness, for any particular purpose, are hereby limited to the duration of this written warranty. We do not warrant that **SHOP FOX**[®] machinery complies with the provisions of any law or acts. In no event shall Woodstock International, Inc.'s liability under this warranty exceed the purchase price paid for the product, and any legal actions brought against Woodstock International, Inc. shall be tried in the State of Washington, County of Whatcom. We shall in no event be liable for death, injuries to persons or property or for incidental, contingent, special or consequential damages arising from the use of our products.

Every effort has been made to ensure that all **SHOP FOX**[®] machinery meets high quality and durability standards. We reserve the right to change specifications at any time because of our commitment to continuously improve the quality of our products.



Warranty Registration

Name _____
 Street _____
 City _____ State _____ Zip _____
 Phone # _____ Email _____ Invoice # _____
 Model # _____ Serial # _____ Dealer Name _____ Purchase Date _____

The following information is given on a voluntary basis. It will be used for marketing purposes to help us develop better products and services. Of course, all information is strictly confidential.

1. How did you learn about us?
 Advertisement Friend Local Store
 Mail Order Catalog Website Other:
2. How long have you been a woodworker/metalworker?
 0-2 Years 2-8 Years 8-20 Years 20+ Years
3. How many of your machines or tools are Shop Fox®?
 0-2 3-5 6-9 10+
4. Do you think your machine represents a good value? Yes No
5. Would you recommend Shop Fox® products to a friend? Yes No
6. What is your age group?
 20-29 30-39 40-49
 50-59 60-69 70+
7. What is your annual household income?
 \$20,000-\$29,000 \$30,000-\$39,000 \$40,000-\$49,000
 \$50,000-\$59,000 \$60,000-\$69,000 \$70,000+
8. Which of the following magazines do you subscribe to?

<input type="checkbox"/> Cabinet Maker	<input type="checkbox"/> Popular Mechanics	<input type="checkbox"/> Today's Homeowner
<input type="checkbox"/> Family Handyman	<input type="checkbox"/> Popular Science	<input type="checkbox"/> Wood
<input type="checkbox"/> Hand Loader	<input type="checkbox"/> Popular Woodworking	<input type="checkbox"/> Wooden Boat
<input type="checkbox"/> Handy	<input type="checkbox"/> Practical Homeowner	<input type="checkbox"/> Woodshop News
<input type="checkbox"/> Home Shop Machinist	<input type="checkbox"/> Precision Shooter	<input type="checkbox"/> Woodsmith
<input type="checkbox"/> Journal of Light Cont.	<input type="checkbox"/> Projects in Metal	<input type="checkbox"/> Woodwork
<input type="checkbox"/> Live Steam	<input type="checkbox"/> RC Modeler	<input type="checkbox"/> Woodworker West
<input type="checkbox"/> Model Airplane News	<input type="checkbox"/> Rifle	<input type="checkbox"/> Woodworker's Journal
<input type="checkbox"/> Modeltec	<input type="checkbox"/> Shop Notes	<input type="checkbox"/> Other:
<input type="checkbox"/> Old House Journal	<input type="checkbox"/> Shotgun News	

9. Comments: _____

CUT ALONG DOTTED LINE

FOLD ALONG DOTTED LINE

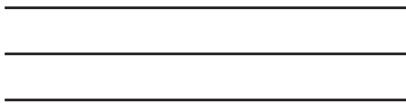

Place
Stamp
Here

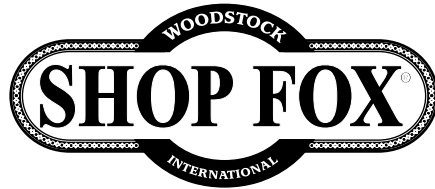

WOODSTOCK INTERNATIONAL INC.
P.O. BOX 2309
BELLINGHAM, WA 98227-2309



FOLD ALONG DOTTED LINE

TAPE ALONG EDGES--PLEASE DO NOT STAPLE

Free Manuals Download Website

<http://myh66.com>

<http://usermanuals.us>

<http://www.somanuals.com>

<http://www.4manuals.cc>

<http://www.manual-lib.com>

<http://www.404manual.com>

<http://www.luxmanual.com>

<http://aubethermostatmanual.com>

Golf course search by state

<http://golfingnear.com>

Email search by domain

<http://emailbydomain.com>

Auto manuals search

<http://auto.somanuals.com>

TV manuals search

<http://tv.somanuals.com>