

MODEL W1775 NAILER/STAPLER KIT



OWNER'S MANUAL

Phone: (360) 734-3482 • Online Technical Support: tech-support@shopfox.biz

COPYRIGHT © JUNE, 2007 BY WOODSTOCK INTERNATIONAL, INC., REVISED DECEMBER, 2007 (JM)
WARNING: NO PORTION OF THIS MANUAL MAY BE REPRODUCED IN ANY SHAPE OR FORM WITHOUT
THE WRITTEN APPROVAL OF WOODSTOCK INTERNATIONAL, INC.

#9568BL Printed in China

WARNING!

This manual provides critical safety instructions on the proper setup, operation, maintenance and service of this machine/equipment.

Failure to read, understand and follow the instructions given in this manual may result in serious personal injury, including amputation, electrocution or death.

The owner of this machine/equipment is solely responsible for its safe use. This responsibility includes but is not limited to proper installation in a safe environment, personnel training and usage authorization, proper inspection and maintenance, manual availability and comprehension, application of safety devices, blade/cutter integrity, and the usage of personal protective equipment.

The manufacturer will not be held liable for injury or property damage from negligence, improper training, machine modifications or misuse.

WARNING!

Some dust created by power sanding, sawing, grinding, drilling, and other construction activities contains chemicals known to the State of California to cause cancer, birth defects or other reproductive harm. Some examples of these chemicals are:

- Lead from lead-based paints.
- Crystalline silica from bricks, cement and other masonry products.
- Arsenic and chromium from chemically-treated lumber.

Your risk from these exposures varies, depending on how often you do this type of work. To reduce your exposure to these chemicals: Work in a well ventilated area, and work with approved safety equipment, such as those dust masks that are specially designed to filter out microscopic particles.

SAFETY

WARNING

For Your Own Safety Read Instruction Manual Before Operating This Equipment

The purpose of safety symbols is to attract your attention to possible hazardous conditions. This manual uses a series of symbols and signal words which are intended to convey the level of importance of the safety messages. The progression of symbols is described below. Remember that safety messages by themselves do not eliminate danger and are not a substitute for proper accident prevention measures.

DANGER

Indicates an imminently hazardous situation which, if not avoided, **WILL** result in death or serious injury.

WARNING

Indicates a potentially hazardous situation which, if not avoided, **COULD** result in death or serious injury.

CAUTION

Indicates a potentially hazardous situation which, if not avoided, **MAY** result in minor or moderate injury. It may also be used to alert against unsafe practices.

NOTICE

This symbol is used to alert the user to useful information about proper operation of the equipment.

WARNING

Safety Instructions for Pneumatic Tools

1. **KEEP ALL SAFETY DEVICES IN PLACE** and in working order.
2. **REMOVE ADJUSTING KEYS AND WRENCHES.** Form habit of checking to see that keys and adjusting wrenches are removed from tool before operation.
3. **KEEP WORK AREA CLEAN.** Cluttered areas and benches invite accidents.
4. **DO NOT USE IN DANGEROUS ENVIRONMENT.** Do not use pneumatic tools in damp or wet locations, or where any flammable or noxious fumes may exist. Keep work area well lighted.
5. **KEEP CHILDREN AND VISITORS AWAY.** All children and visitors should be kept at a safe distance from work area.
6. **MAKE WORKSHOP CHILD PROOF** by locking your shop and shutting off air valves.
7. **DO NOT FORCE TOOL.** It will do the job better and safer at the rate for which it was designed.
8. **USE THE RIGHT TOOL.** Do not force tool or attachment to do a job for which it was not designed.
9. **DO NOT USE UNDER THE INFLUENCE OF DRUGS OR ALCOHOL.**

WARNING

Safety Instructions for Pneumatic Tools

10. **USE PROPER AIR HOSE** for the tool. Make sure your air hose is in good condition and is long enough to reach your work without stretching.
11. **WEAR PROPER APPAREL.** Do not wear loose clothing, gloves, neckties, rings, bracelets, or other jewelry which may get caught in moving parts. Non-slip footwear is recommended. Wear a protective hair covering to contain long hair.
12. **ALWAYS USE SAFETY GLASSES.** Also use a face or dust mask if cutting operation is dusty. Everyday eyeglasses only have impact resistant lenses, they are NOT safety glasses.
13. **WEAR APPROVED HEARING PROTECTION.** Air escaping from pneumatic tools can exceed safe exposure limits and may cause hearing damage with prolonged exposure.
14. **SECURE WORK.** Use clamps or a vise to hold work when practical. It is safer than using your hand and frees both hands to operate tool.
15. **MAINTAIN TOOLS WITH CARE.** Keep tools lubricated and clean for best and safest performance. Follow instructions for lubricating and changing accessories.
16. **REDUCE THE RISK OF UNINTENTIONAL FIRING.** Do not carry tool with hand on trigger and always disconnect from air when not in use.
17. **DISCONNECT TOOLS** before servicing, changing accessories, or moving to another location.
18. **DO NOT OVERREACH.** Keep proper footing/balance at all times.
19. **USE THE RECOMMENDED ACCESSORIES.** Consult owner's manual for recommended accessories. The use of improper accessories may cause risk of injury.
20. **CHECK FOR DAMAGED PARTS BEFORE USING.** Check for binding and alignment of parts, broken parts, part mounting, loose bolts, and any other conditions that may affect machine operation. Repair or replace damaged parts.
21. **NEVER LEAVE UNATTENDED TOOL CONNECTED TO AIR.** Disconnect the air hose and do not leave tool until it is relieved of any built up pressure.
22. **NEVER ALLOW UNTRAINED USERS TO USE THIS TOOL WHILE UNSUPERVISED.**
23. **IF YOU ARE UNSURE OF THE INTENDED OPERATION, STOP USING TOOL.** Seek formal training or research books or magazines that specialize in pneumatic tools.
24. **BE AWARE OF HOSE LOCATION WHEN USING PNEUMATIC TOOLS.** Hoses can easily become a tripping hazard when laid across the floor or spread out in a disorganized fashion.

WARNING

Additional Safety for Nailers/Staplers

- 1. HAND INJURIES:** Do not place your hands near the nail/staple point of entry. A nail/staple can deflect and tear through the surface of the workpiece, puncturing your hand or fingers.
- 2. COMBUSTIBLE GASES:** Never connect the nailer/stapler to pressurized oxygen or other combustible gases as a power source. Only use filtered, lubricated, and regulated compressed air.
- 3. SAFE HANDLING:** Never point the nail/stapler at others! Do not keep the trigger pulled when loading fasteners, carrying, or holding tool. Carry the nailer/stapler only by the handle, never by any other part. Do not carry the nailer/stapler by the air hose. Disconnect the nailer/stapler from the air hose when going up and down ladders.
- 4. CLEANING:** Never use gasoline or other flammable liquids to clean the nailer/stapler; vapors in the nailer/stapler will ignite by a spark and cause it to explode.
- 5. HOSE USAGE:** Make sure your air hose is designed for the tool in use, is in good condition, and is long enough to reach your work without stretching. However, an overly long air hose in the work area may be a tripping hazard.
- 6. OPERATING QUESTIONS:** If you are not sure about the intended operation, stop using the nailer/stapler. Seek formal training.
- 7. MAINTENANCE:** Always disconnect air from the nailer/stapler when servicing or installing nails. During maintenance, a nailer/stapler connected to air may fire accidentally, causing serious personal injury.
- 8. COMPRESSED AIR RATING:** Do not connect the nailer/stapler to compressed air that exceeds 120 PSI.
- 9. CHECK VALVE:** Do not use a check valve or any other fitting that allows air to remain in the tool.
- 10. MODIFICATION:** Do not modify this tool or bypass the safety nose mechanism.

WARNING

Never point this nailer/stapler at yourself or another person! Always pay attention to the direction this nailer/stapler is pointed. Use this tool with respect and caution to lessen the possibility of operator or bystander injury. Ignoring this warning may result in serious personal injury.

CAUTION

Nailer/stapler accidents routinely happen while moving the gun to another location, such as up ladders, to another room, or even another job site. Always disconnect the gun immediately after use and never transport the gun while connected to the air—even if the air compressor is disconnected from its power source!

INTRODUCTION

Woodstock Technical Support

This tool has been specially designed to provide many years of trouble-free service. Close attention to detail, ruggedly built parts and a rigid quality control program assure safe and reliable operation.

Woodstock International, Inc. is committed to customer satisfaction. Our intent with this manual is to include the basic information for safety, setup, operation, maintenance, and service of this product.

We stand behind our tools! In the event that questions arise about your tool, please contact Woodstock International Technical Support at (360) 734-3482 or send e-mail to: tech-support@shopfox.biz. Our knowledgeable staff will help you troubleshoot problems and process warranty claims.

If you need the latest edition of this manual, you can download it from <http://www.shopfox.biz>.

If you have comments about this manual, please contact us at:

Woodstock International, Inc.
Attn: Technical Documentation
Manager
P.O. Box 2309
Bellingham, WA 98227
Email: manuals@woodstockint.com

Tool Data

Brad Length.....	5/8"-2" (18 Gauge)
Staple Length.....	5/8"-1 5/8"
Staple Crown	1/4" (18 Gauge)
Magazine Capacity.....	100 pieces
Air Inlet.....	1/4" NPT
Weight	3.3 lbs.
Operating Pressure	60-100 PSI

WARNING

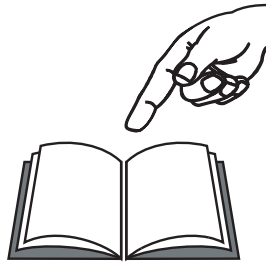

Read the manual before operation. Become familiar with this nailer/stapler, its safety instructions, and its operation before beginning any work. Serious personal injury may result if safety or operational information is not understood or followed.

CAUTION

No list of safety guidelines can be complete. Every shop environment is different. Always consider safety first, as it applies to your individual working conditions. Use this and other tools with caution and respect. Failure to do so could result in serious personal injury, damage to equipment or poor work results.

Compressed Air System

The Model W1775 is designed to be operated at 60-100 PSI using clean, dry, regulated, compressed air. **Do not exceed the 120 PSI maximum operating pressure for your model.**

Before using your new nailer/stapler, regulate the air pressure to find the optimum setting within the specified operating range. Start by testing the nailer/stapler at a low setting, then increase the air pressure as needed for satisfactory results.

An in-line filter/lubricator/regulator unit can be installed as depicted in **Figure 1**.

This filter/lubricator/regulator unit will protect your tool from damaging water build-up, allow you to adjust and maintain regulated air pressure to your tool, and save you the inconvenience of having to manually lubricate your tool every time you use it.

If you plan on installing a filter/lubricator/regulator unit in your compressed air system, always follow the connection instructions that come with the unit.



CAUTION

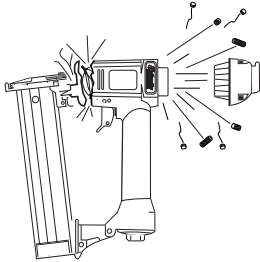

Exceeding the maximum permissible operating pressure may damage the nailer/stapler and cause it to malfunction. To protect yourself from personal injury, DO NOT allow the air pressure to exceed the recommended pressure for this nailer/stapler!

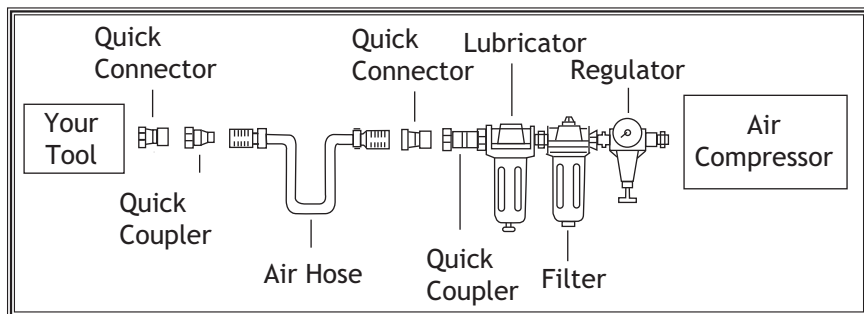

Figure 1. Typical filter/lubricator/regulator installation order.

SETUP

Unpacking

This tool has been carefully packaged for safe transportation. If you notice the tool has been damaged during shipping, please contact your authorized Shop Fox dealer immediately.

Inventory

The following is a description of the main components shipped with the Model W1775. Lay the components out to inventory them.

Note: *If you can't find an item on this list, check the mounting location on the tool or examine the packaging materials carefully. Occasionally we pre-install certain components for safer shipping.*

Box Inventory (Figure 2)	Qty		Qty
A. 2-in-1 Nailer/Stapler	1	D. Safety Goggles.....	1
B. Pneumatic Tool Oil	1	E. Hex Wrench 3mm	1
C. Carrying Case	1	F. Hex Wrench 4mm	1

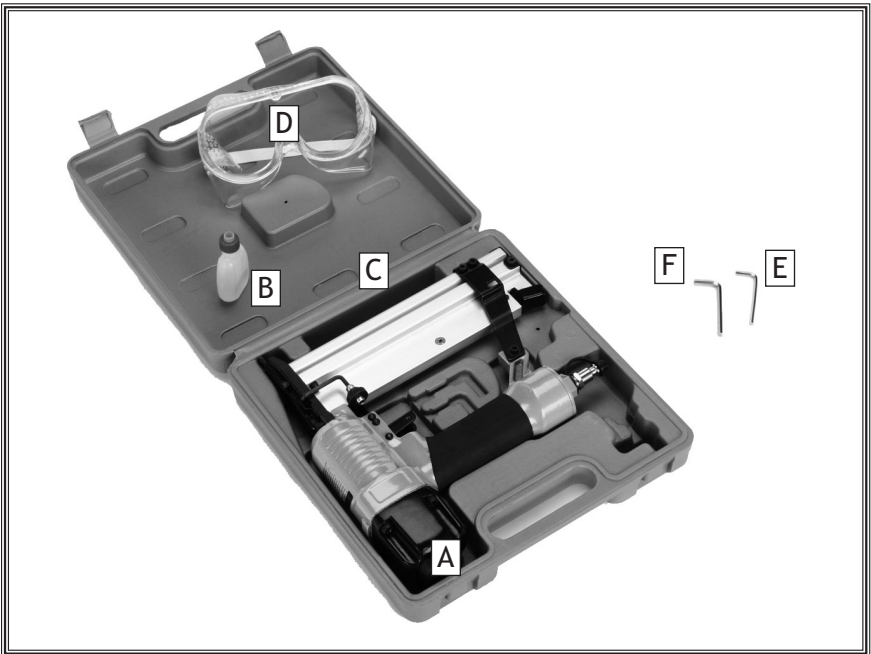

Figure 2. Model W1775 inventory.

Safety Nose Mechanism

A safety mechanism on the nose of the nailer/stapler protects against accidental firing. When the trigger is pressed, the nailer/stapler will not fire until the safety nose mechanism is depressed.

Before you use your nailer/stapler for the first time, check the safety nose mechanism to ensure proper function.

To check the safety nose mechanism, do these steps:

1. DISCONNECT NAILER/STAPLER FROM THE AIR SUPPLY!
2. Make sure the magazine is empty and contains no nails/staples.
3. Make sure the trigger and the safety nose mechanism move up and down without sticking.
4. Connect the nailer/stapler to the air supply.
5. **Without pressing the trigger**, depress the safety nose mechanism against a scrap piece of wood that is clean and free of any knots, nails, or other foreign objects.
 - If the nailer/stapler **does not fire**, then the safety nose mechanism is working correctly.
 - If the nailer/stapler **does fire** when you do this, immediately disconnect the nailer/stapler from the air supply and call Technical Support.

- If the nailer/stapler fires when the trigger is pulled, without the safety nose mechanism being depressed, then the nailer/stapler is not working properly.
- If you find that the safety nose mechanism is not working properly, check the lubrication of its sliding components.

WARNING

Do not attempt to modify or bypass the safety nose mechanism to make the nailer/stapler fire without pushing the nose down.

WARNING

The safety mechanism is a mechanical device that can fail. Never rely on this mechanism as an excuse to point the nailer/stapler at yourself or any bystanders. Serious injury may occur.

WARNING



Operating this nailer/stapler can propel objects into the air, causing immediate eye damage. To protect yourself, always wear ANSI approved safety glasses or goggles when operating this equipment.

OPERATIONS

Loading

When replacing brad nails in your Model W1775, follow these guidelines:

Gauge: 18

Brad Length: $\frac{5}{8}$ "-2"

Staple Length: $\frac{5}{8}$ "-1 $\frac{5}{8}$ " (crown $\frac{1}{4}$ ")

Capacity: 100

To load your nailer/stapler, do these steps:

1. DISCONNECT NAILER/STAPLER FROM THE AIR SUPPLY!
2. Grip the nailer/stapler firmly, unlatch the catch lever (Figure 3), and pull the magazine pusher back completely.



Figure 3. Catch lever engaged and magazine pusher retracted.

3. Insert a strip of brads or staples, pointed-end down, into the magazine as shown in Figure 4.

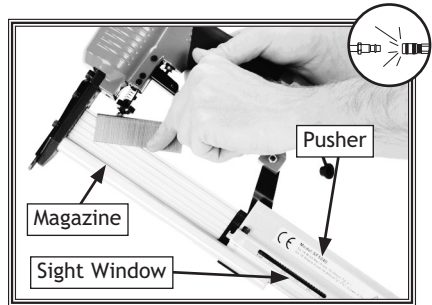

Figure 4. Loading nails into magazine.

4. Slide the staples or brads all the way down to the nose of the nailer/stapler.
5. Push the magazine toward the nose of the nailer/stapler until the catch lever locks.
6. Reload the nailer/stapler when the magazine sight window (Figure 4) shows the nail or staple level is low. The sight window shows up to approximately 50 nails or staples loaded.

Operating

If you have not read the safety instructions in this manual, do not operate the nailer/stapler.

Before you operate your nailer/stapler, place two to three drops of the included oil into the quick connect fitting where the nailer/stapler connects to the air supply, unless using a lubricator unit.

To operate your nailer/stapler, do these steps:

1. Connect the air supply to the quick connect fitting.

2. To test for proper nail penetration, hold the nailer/stapler perpendicular to the surface of a piece of clean scrap wood that is thick enough for the length of nails/staples you have loaded.
3. Depress the safety nose mechanism against your workpiece.
4. Before pulling the trigger, make sure your free hand and other body parts are positioned out of the way of a potential path of a nail/staple in case of deflection.

Deflection is caused when grain irregularities, knots or foreign objects inside the wood cause the nail/staple to change its path, resulting in the nail/staple puncturing the surface of the workpiece, as shown in **Figure 5**.

Besides damaging your workpiece, deflection can cause injury if your free hand is securing the workpiece in the location that the nail/staple deflects.

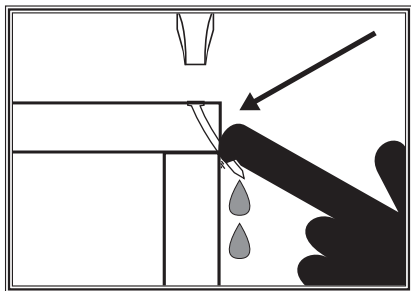

Figure 5. Example of nail deflection.

5. Pull the trigger.

– If the nail/staple drove into the wood far enough, continue with your intended operations.

– If the nail/staple either went too far or not far enough, then go to the **Adjusting Depth** section on this page.

Adjusting Depth

A depth adjustment knob is attached to the nose for setting the nail/staple depth.

To adjust the depth, do these steps:

1. DISCONNECT NAILER/STAPLER FROM THE AIR SUPPLY!
2. Rotate the adjustment knob (**Figure 6**) clockwise to increase depth or counterclockwise to decrease depth.

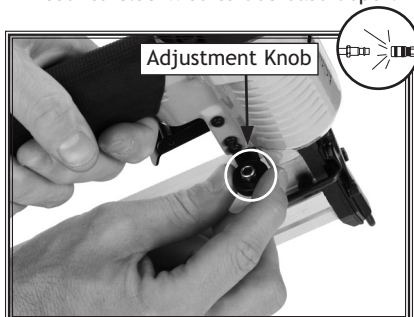

Figure 6. Loosening cap screw for depth adjustment.

3. Connect nailer/stapler to the air supply and test the nail depth. Repeat this entire procedure if necessary until the nail/staple depth is satisfactory.

CAUTION

DO NOT place your hands near the staple point of entry. A nail/staple can deflect and tear through the surface of the workpiece, puncturing your hand or fingers.

Clearing Jammed Nails

A jammed nail or staple must be cleared before using the nailer/stapler again.

To clear a jammed nail or staple from the magazine, do these steps:

1. DISCONNECT NAILER/STAPLER FROM THE AIR SUPPLY!
2. Unlock the catch lever and pull the magazine pusher back completely.
3. Locate and remove the jammed nail/staple with a pair of needle nose pliers.
4. Throw the damaged nail/staple away.
5. Inspect the nail/staple stick. If it is bent or damaged, throw it away and insert a new stick that only contains clean, undamaged nails/staples. DO NOT use dirty or damaged nails/staples!
6. Push the magazine pusher forward to the front of the magazine until the catch lever locks.

To clear a jammed nail from the discharge area, do these steps:

1. DISCONNECT NAILER/STAPLER FROM THE AIR SUPPLY!
2. Unlock the catch lever and pull the magazine pusher back completely.
3. Remove the nail/staple stick from the magazine.
4. Loosen the cap screws shown in **Figure 7**, and remove the cover with a 3mm hex wrench. Dislodge the jammed nail/staple with a pair of needle nose pliers.

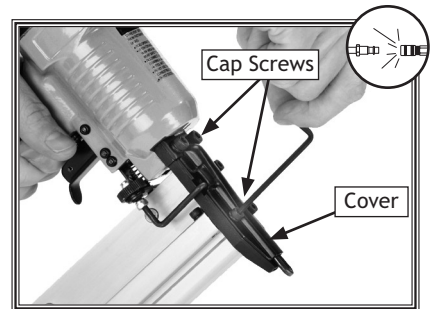

Figure 7. Opening cover to clear a jam.

5. Secure the cover with the cap screws removed in **Step 4**.
6. Throw the damaged nail/staple away.
7. Inspect the nail/staple stick. If it is bent or damaged, throw it away and insert a new stick that only contains clean, undamaged nails/staples. DO NOT use dirty or damaged nails/staples!
8. Slide the magazine pusher forward to the front of the magazine until the catch lever locks.

Replacing Piston and O-Rings

Under heavy use, a piston or piston shaft may wear out. Replacement is quick and easy. Contact your authorized Shop Fox dealer to obtain the Piston Repair Kit (part number X1775001).



To replace a piston and O-rings, do these steps:

1. DISCONNECT NAILER/STAPLER FROM THE AIR SUPPLY!
2. Remove all nails/staples from the magazine cartridge, and clean the exterior of the nailer.
3. Remove the four cap screws on the back of the nailer/stapler, near the exhaust port.
4. Remove the cap.
5. The top of the piston should now be visible inside the cylinder, which is housed in the head of the nailer/stapler.
6. Open the nose cover as if to clear a jammed nail/staple.
7. Watch the discharge area and push the top of the piston with your finger. You will see the piston shaft slide down the discharge area.
8. Taking care not to scratch or dent the nailer parts, use a wooden dowel or similarly shaped tool to push the piston shaft back inside the nailer/stapler until you can grip the piston head and remove it from the cylinder. Clean and inspect the parts for cracks, wear, or burrs.
9. Place a new O-ring on the new piston and apply a thin film of the nailer/stapler lubricating oil on the O-ring.
10. Insert the new piston in the cylinder. Make sure that the grooves on the piston shaft line up with those on the guide at the bottom of the cylinder. The new piston should easily slide into the cylinder. **DO NOT force the piston into the cylinder!** If the piston is not easily inserted, double-check the alignment of the piston shaft with the grooves on the guide.
11. After the piston is inserted correctly, close the magazine. Replace the rear cap assembly and tighten the four cap screws.
12. For more assistance, or to install a complete O-ring set, refer to the appropriate breakdown diagram in the back of this manual for component locations.

CLEANING & LUBRICATION

Cleaning

Disconnect the nailer/stapler from the air supply before cleaning. Use a good solvent to clean the nose assembly of the nailer/stapler. Always be sure that the nailer/stapler is dry before using it again.

Do not allow dust, chips, sand, etc. into the air connectors or into the body of the nailer/stapler; this may result in leaks and damage to the nailer/stapler and the air couplings.



WARNING



Never use gasoline or other flammable liquids to clean this tool. Vapors in the tool may ignite, causing the tool to explode. Ignoring this warning may lead to serious personal injury or even death!

Lubricating

Standard pneumatic tool oil has been included with your new Shop Fox nailer/stapler to help maintain its useful life. Place two to three drops of oil in the nailer/stapler air inlet (as shown in **Figure 8**) before every use, or after 2 hours of continuous use.

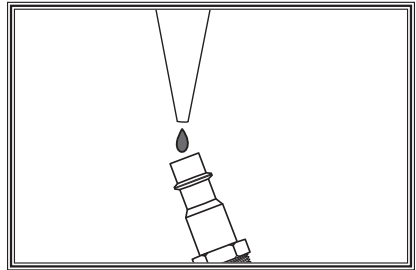
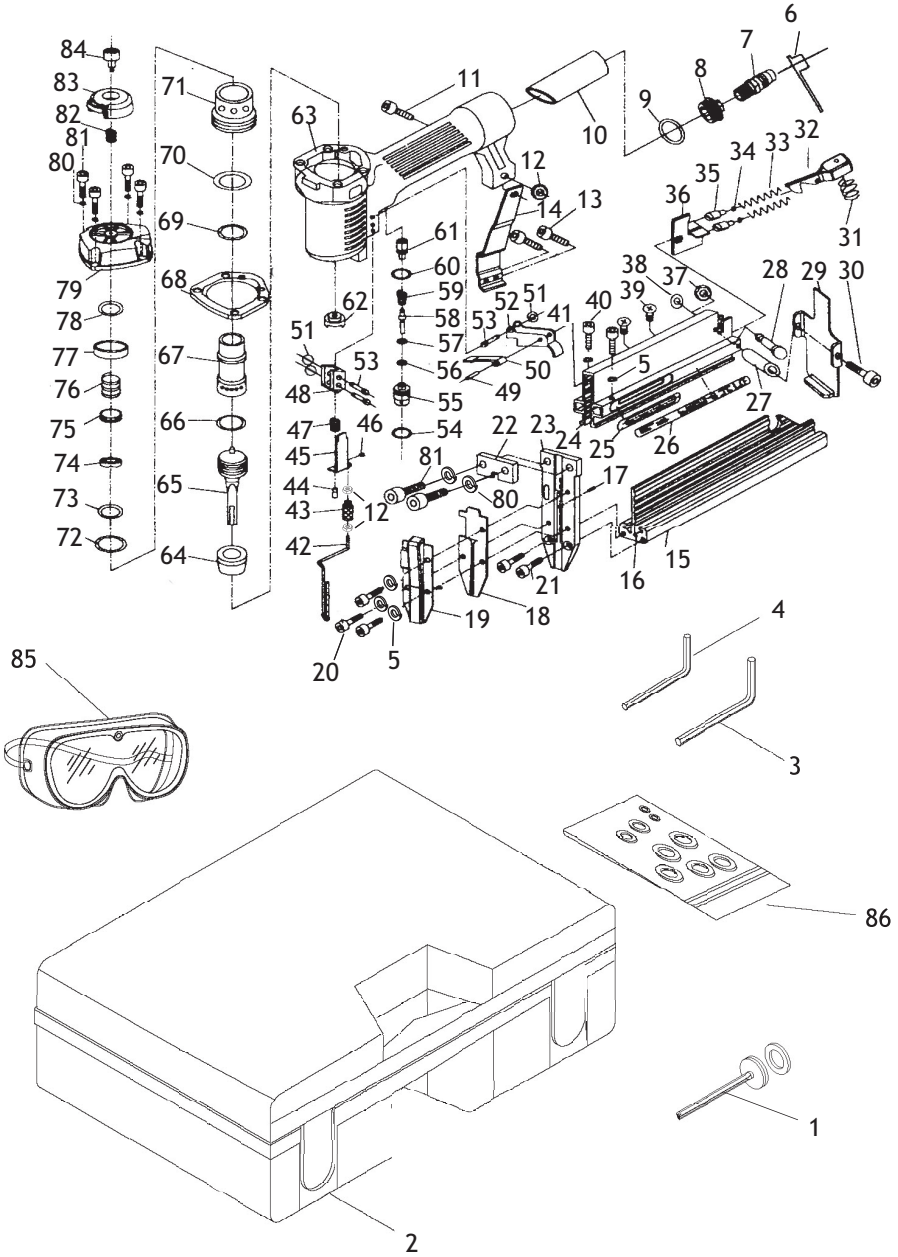

Figure 8. Lubricating nailer/stapler via air inlet.

Wipe off any excess oil near the nailer/stapler exhaust to avoid dust build-up. When the oil that was included with the nailer/stapler has been completely used, replace with a quality pneumatic tool oil.

An alternative to manual oiling is to install a lubricator in your air compressor line. A lubricator eliminates the need to oil your tool each time you use it. If you have a lubricator in your air compressor line, ensure it is functioning properly.

PARTS BREAKDOWN



PARTS LIST

REF	PART #	DESCRIPTION
1	X1775001	PISTON REPAIR KIT
2	X1775002	CARRYING CASE
3	XPAW04M	HEX WRENCH 4MM
4	XPAW03M	HEX WRENCH 3MM
5	XPLW02M	LOCK WASHER 4MM
6	X1775006	AIR PLUG COVER
7	X1775007	1/4" NPT MALE CONNECT
8	X1775008	END CAP
9	X1775009	O-RING 36.3 X 3.55
10	X1775010	RUBBER HANDLE CASE
11	XPSB16M	CAP SCREW M4-.7 X 16
12	XPN04M	HEX NUT M4-.7
13	XPSB18M	CAP SCREW M4-.7 X 8
14	X1775014	FIXED SEAT
15	X1775015	MAGAZINE
16	X1775016	INLAY SLICE
17	X1775017	PIN 1.5 X 12
18	X1775018	DRIVER GUIDE
19	X1775019	NOSE COVER
20	XPSB17M	CAP SCREW M4-.7 X 10
21	XPSB41M	CAP SCREW M4-.7 X 14
22	X1775022	SPACER
23	X1775023	NOSE
24	X1775024	SLIDING MAGAZINE
25	X1775025	SCALE
26	X1775026	STICKER PLATE
27	X1775027	PIPE
28	X1775028	PIN 3.93 X 15.50
29	X1775029	FIXED SEAT
30	XPSB22M	CAP SCREW M4-.7 X 35
31	X1775031	COMPRESSION SPRING
32	X1775032	CATCH LEVER
33	X1775033	COMPRESSION SPRING
34	X1775034	O-RING 4.5 x 1.2
35	X1775035	PUSHER STICK
36	X1775036	PUSHER
37	X1775037	PUSHER STICK
38	X1775038	O-RING 2.4 X 1.8
39	XPFH32M	FLAT HD SCR M4-.7 X 6
40	XPSB23M	CAP SCREW M4-.7 X 12
41	X1775041	BAR
42	X1775042	SAFETY YOKE
43	X1775043	ADJUSTING NUT

REF	PART #	DESCRIPTION
44	X1775044	RETAINER SNAP
45	X1775045	STAND PLATE
46	XPEC12M	E-CLIP 12MM
47	X1775047	COMPRESSION SPRING
48	X1775048	STAND
49	XPRP12M	ROLL PIN 2.5 X 18
50	X1775050	SAFETY PLATE
51	X1775051	O-RING 2.96 X 1.7
52	X1775052	TRIGGER
53	X1775053	PIN 2.97 X 30
54	X1775054	O-RING 11.2 X 1.85
55	X1775055	TRIGGER VALVE GUIDE
56	X1775056	O-RING 1.9 X 1.1
57	X1775057	O-RING 8 X 1
58	X1775058	VALVE STEM
59	X1775059	COMPRESSION SPRING
60	X1775060	O-RING 11 X 1.2
61	X1775061	PISTON VALVE
62	X1775062	GROMMET
63	X1775063	BODY
64	X1775064	BUMPER
65	X1775065	PISTON ASSEMBLY
66	X1775066	O-RING 29.7 X 3.55
67	X1775067	CYLINDER
68	X1775068	SEALING GASKET
69	X1775069	O-RING 30 X 1.8
70	X1775070	O-RING 42.6 X 2.35
71	X1775071	COLLAR
72	X1775072	O-RING 31.2 X 2.5
73	X1775073	O-RING 24.8 X 3.5
74	X1775074	SEALING WASHER
75	X1775075	ON/OFF VALVE
76	X1775076	COMPRESSION SPRING
77	X1775077	SEALING WASHER
78	X1775078	O-RING 13 X 2.4
79	X1775079	CYLINDER COVER
80	XPLW01M	LOCK WASHER 5MM
81	XPSB15M	CAP SCREW M5-.8 X 20
82	X1775082	COMPRESSION SPRING
83	X1775083	AIR DEFLECTOR
84	X1775084	SPCL CAP SCR M4-.7 X 20
85	X1775085	SAFETY GLASSES
86	X1775086	COMPLETE O-RING SET

Troubleshooting

Symptom	Possible Cause	Possible Solution
Air leaking at trigger valve area.	1. O-rings in trigger valve housing are damaged.	1. O-rings must be replaced & operation of safety nose must be checked.
Air leaking between housing and hose	1. Loose screws in housing. 2. Damaged O-ring. 3. Loose air fitting.	1. Reseal and tighten screws. 2. Replace O-ring 3. Tighten air fitting & use teflon tape.
Air leaking between housing and cap.	1. Damaged seal.	1. Replace damaged seals.
Tool skips nails while discharging.	1. Excessive air pressure. 2. Air leaks. 3. Dirt in nose. 4. Dirt or damage prevents nails from moving freely. 5. Inadequate air flow to tool. 6. Worn piston O-ring or lack of lubrication. 7. Damaged trigger valve O-rings. 8. Worn bumper. 9. Cap seal leaking.	1. Reduce air pressure to tool. 2. Reseal and tighten screws and fittings. 3. Clean nose. 4. Clean magazine and inspect/repair damage. 5. Check fittings, hose, compressor, and air pressure. 6. Replace O-ring and lubricate. 7. Replace trigger valve O-rings. 8. Replace bumper. 9. Replace cap seal.
Tool runs slowly or has a loss of power.	1. Undersized air hose. 2. Nailer/stapler is not lubricated. 3. Broken spring in cap assembly. 4. Exhaust port in cap is blocked.	1. Use a larger hose. 2. Lubricate nailer/stapler. 3. Replace spring. 4. Clean or replace damaged internal parts.
Fasteners frequently jam the nailer/stapler.	1. Fasteners are the wrong size. 2. Nailer is not lubricated. 3. Fasteners are bent or dirty. 4. Magazine or nose screws are loose. 5. Driver or driver guide are worn or damaged.	1. Use correct nails. 2. Follow lubricating instructions. 3. Use undamaged, clean nails. 4. Tighten magazine. 5. Replace worn or damaged parts.
Nailer/stapler does not fire.	1. Fastener is jammed in magazine or discharge area. 2. Piston shaft is damaged. 3. Air pressure too low.	1. Clear magazine or discharge area. 2. Replace piston shaft. 3. Check/increase air pressure.

WARRANTY AND RETURNS

Woodstock International, Inc. warrants its pneumatic equipment to be free of defects from workmanship and materials for a period of 1 year from the date of original purchase. The liability under this warranty shall not exceed the purchase price paid for the products and is limited to credit for, or replacement of the defective part.

We do not warrant or represent that the merchandise complies with the provision of any law or acts, and buyer assumes all risk and liability resulting from the use of the goods, whether using singly or in combination with other products.

This warranty does not apply to defects or damages due directly or indirectly from misuse, abuse, negligence, accidents, repairs or alterations, or lack of maintenance of our products. We shall in no event be liable for death or injuries to persons or property or for incidental, contingent, special or consequential damages arising from the use of our products. This disclaimer applies to both during and after the term of this warranty. Any legal actions brought against Woodstock International, Inc. shall be tried in the State of Washington, County of Whatcom.

Woodstock International, Inc. reserves the right to implement any changes in specifications or discontinue any products without notice.

Warranty Registration

Name _____

Street _____

City _____ State _____ Zip _____

Phone # _____ Email _____ Invoice # _____

Model # _____ Serial # _____ Dealer Name _____ Purchase Date _____

The following information is given on a voluntary basis. It will be used for marketing purposes to help us develop better products and services. Of course, all information is strictly confidential.

1. How did you learn about us?

Advertisement Friend Local Store
 Mail Order Catalog Website Other:

2. How long have you been a woodworker/metalworker?

0-2 Years 2-8 Years 8-20 Years 20+ Years

3. How many of your machines or tools are Shop Fox?

0-2 3-5 6-9 10+

4. Do you think your tool represents a good value?

Yes No

5. Would you recommend Shop Fox products to a friend?

Yes No

6. What is your age group?

20-29 30-39 40-49
 50-59 60-69 70+

7. What is your annual household income?

\$20,000-\$29,000 \$30,000-\$39,000 \$40,000-\$49,000
 \$50,000-\$59,000 \$60,000-\$69,000 \$70,000+

8. Which of the following magazines do you subscribe to?

<input type="checkbox"/> Cabinet Maker	<input type="checkbox"/> Popular Mechanics	<input type="checkbox"/> Today's Homeowner
<input type="checkbox"/> Family Handyman	<input type="checkbox"/> Popular Science	<input type="checkbox"/> Wood
<input type="checkbox"/> Hand Loader	<input type="checkbox"/> Popular Woodworking	<input type="checkbox"/> Wooden Boat
<input type="checkbox"/> Handy	<input type="checkbox"/> Practical Homeowner	<input type="checkbox"/> Woodshop News
<input type="checkbox"/> Home Shop Machinist	<input type="checkbox"/> Precision Shooter	<input type="checkbox"/> Woodsmith
<input type="checkbox"/> Journal of Light Cont.	<input type="checkbox"/> Projects in Metal	<input type="checkbox"/> Woodwork
<input type="checkbox"/> Live Steam	<input type="checkbox"/> RC Modeler	<input type="checkbox"/> Woodworker West
<input type="checkbox"/> Model Airplane News	<input type="checkbox"/> Rifle	<input type="checkbox"/> Woodworker's Journal
<input type="checkbox"/> Modeltec	<input type="checkbox"/> Shop Notes	<input type="checkbox"/> Other:
<input type="checkbox"/> Old House Journal	<input type="checkbox"/> Shotgun News	

9. Comments: _____

CUT ALONG DOTTED LINE

FOLD ALONG DOTTED LINE

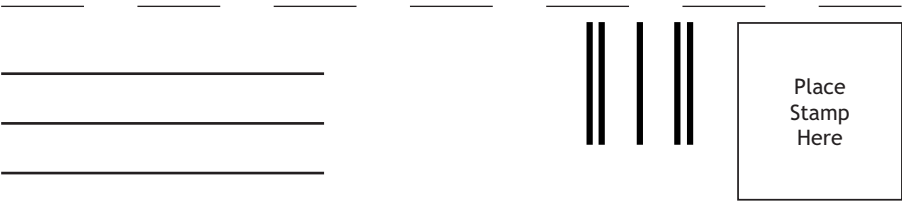

WOODSTOCK INTERNATIONAL INC.
P.O. BOX 2309
BELLINGHAM, WA 98227-2309



FOLD ALONG DOTTED LINE

TAPE ALONG EDGES--PLEASE DO NOT STAPLE

Free Manuals Download Website

<http://myh66.com>

<http://usermanuals.us>

<http://www.somanuals.com>

<http://www.4manuals.cc>

<http://www.manual-lib.com>

<http://www.404manual.com>

<http://www.luxmanual.com>

<http://aubethermostatmanual.com>

Golf course search by state

<http://golfingnear.com>

Email search by domain

<http://emailbydomain.com>

Auto manuals search

<http://auto.somanuals.com>

TV manuals search

<http://tv.somanuals.com>