

# MODEL W1693 MINI PLANER/MOULDER



# INSTRUCTION MANUAL

Phone: 1-360-734-3482 • On-Line Technical Support: [tech-support@woodstockint.com](mailto:tech-support@woodstockint.com)

**COPYRIGHT © MAY, 2004 BY WOODSTOCK INTERNATIONAL, INC.**

**WARNING: NO PORTION OF THIS MANUAL MAY BE REPRODUCED IN ANY SHAPE OR FORM WITHOUT  
THE WRITTEN APPROVAL OF WOODSTOCK INTERNATIONAL, INC.**

Printed in Taiwan

# WARNING

Some dust created by power sanding, sawing, grinding, drilling, and other construction activities contains chemicals known to the State of California to cause cancer, birth defects or other reproductive harm. Some examples of these chemicals are:

- Lead from lead-based paints.
- Crystalline silica from bricks, cement, and other masonry products.
- Arsenic and chromium from chemically treated lumber.

Your risk from these exposures varies, depending on how often you do this type of work. To reduce your exposure to these chemicals: work in a well ventilated area, and work with approved safety equipment, such as those dust masks that are specially designed to filter out microscopic particles.

# Contents

<b>INTRODUCTION</b> .....	<b>2</b>
About Your New Mini Planer/Moulder .....	2
Woodstock Service and Support .....	2
Warranty and Returns .....	3
Specifications .....	3
<b>SAFETY</b> .....	<b>4</b>
Safety Instructions for Power Tools .....	4
Additional Safety Instructions for Planer/Moulders .....	6
Avoiding Potential Injuries .....	7
<b>ELECTRICAL</b> .....	<b>8</b>
220V Operation .....	8
Extension Cords .....	8
Grounding .....	8
<b>ASSEMBLY</b> .....	<b>9</b>
Overview .....	9
Inventory .....	9
Shop Preparation .....	10
Cleaning Moulder .....	10
Rubber Feet .....	11
Switch .....	11
Planer/Moulder Head .....	12
Drive Belt .....	12
Depth Control Handle .....	13
Extension Rollers .....	13
Belt Guard .....	14
Dust Hood .....	14
Gear Box .....	14
<b>ADJUSTMENTS</b> .....	<b>15</b>
Planer/Moulder Overview .....	15
Test Run .....	16
Feed Roller-to-Table Alignment .....	17
Feed Roller Spring Tension .....	18
<b>OPERATIONS</b> .....	<b>19</b>
Operational Tips .....	19
Moulding Knives .....	20
Moulding Fences .....	21
Bedboard .....	21
Moulding .....	22
Replacing Planer Knives .....	23
Planing .....	24
Planing Tips .....	25
<b>MAINTENANCE</b> .....	<b>26</b>
General .....	26
Cleaning .....	26
Table .....	26
Lubrication .....	27
Troubleshooting .....	28
Planer/Moulder Accessories .....	29
Parts Diagrams and Lists .....	30
Warranty Card .....	35

USE THE QUICK GUIDE PAGE LABELS TO SEARCH OUT INFORMATION FAST!



# INTRODUCTION

## About Your New Mini Planer/Moulder

Your new SHOP FOX® Planer/Moulder has been specially designed to provide many years of trouble-free service. Close attention to detail, ruggedly built parts and a rigid quality control program assure safe and reliable operation.

This Planer/Moulder has a stationary table and a moveable headstock, which makes readjusting the infeed and outfeed rollers unnecessary. The Model W1693 has a 2 H.P. motor connected with a link belt to a two-knife cutterhead which drives the infeed and outfeed rollers. The open sided design allows unrestricted space for profiling mouldings and panels, and allows curved mouldings with the optional Model W3393 Elliptical Jig. A large selection of HSS moulding profiles are available from Woodstock International, Inc.

Woodstock International, Inc. is committed to customer satisfaction in providing this manual. It is our intent to make sure all the information necessary for safety, ease of assembly, practical use and durability of this product be included.

If you need the latest edition of this manual, you can download it from <http://www.shopfox.biz>.  
If you still have questions after reading the latest manual, or if you have comments please contact us at:

**Woodstock International, Inc.**  
**Attn: Technical Support Department**  
**P.O. Box 2309**  
**Bellingham, WA 98227**

## Woodstock Service and Support

We stand behind our machines! In the event that a defect is found, parts are missing or questions arise about your machine, please contact Woodstock International Service and Support at 1-360-734-3482 or send e-mail to: [tech-support@shopfox.biz](mailto:tech-support@shopfox.biz). Our knowledgeable staff will help you troubleshoot problems, send out parts or arrange warranty returns.

# Warranty and Returns

Woodstock International, Inc. warrants all SHOP FOX® machinery to be free of defects from workmanship and materials for a period of 2 years from the date of original purchase by the original owner. This warranty does not apply to defects due directly or indirectly to misuse, abuse, negligence or accidents, lack of maintenance, or to repair or alterations made or specifically authorized by anyone other than Woodstock International, Inc.

Woodstock International, Inc. will repair or replace, at its expense and at its option, the SHOP FOX® machine or machine part which in normal use has proven to be defective, provided that the original owner returns the product prepaid to the SHOP FOX® factory service center or authorized repair facility designated by our Bellingham, WA office, with proof of their purchase of the product within 2 years, and provides Woodstock International, Inc. reasonable opportunity to verify the alleged defect through inspection. If it is determined there is no defect, or that the defect resulted from causes not within the scope of Woodstock International Inc.'s warranty, then the original owner must bear the cost of storing and returning the product.

This is Woodstock International, Inc.'s sole written warranty and any and all warranties that may be implied by law, including any merchantability or fitness, for any particular purpose, are hereby limited to the duration of this written warranty. We do not warrant that SHOP FOX® machinery complies with the provisions of any law or acts. In no event shall Woodstock International, Inc.'s liability under this warranty exceed the purchase price paid for the product, and any legal actions brought against Woodstock International, Inc. shall be tried in the State of Washington, County of Whatcom. We shall in no event be liable for death, injuries to persons or property or for incidental, contingent, special or consequential damages arising from the use of our products.

Every effort has been made to ensure that all SHOP FOX® machinery meets high quality and durability standards. We reserve the right to change specifications at any time because of our commitment to continuously improve the quality of our products.

## Specifications

Motor .....	2 H.P. , 12A, 220V, Single-Phase
Maximum Planing Width.....	7"
Maximum Profile Width .....	6 <sup>3</sup> / <sub>4</sub> "
Maximum Profile Depth .....	<sup>3</sup> / <sub>4</sub> "
Minimum Stock Thickness.....	<sup>1</sup> / <sub>4</sub> "
Minimum Stock Length .....	9"
Cutterhead Speed .....	7,000 RPM
Cuts Per-Minute.....	14,000
Approximate Handwheel Rotation-to-Cutterhead Travel.....	360°= <sup>3</sup> / <sub>32</sub> "
Dust Port Size .....	4"
Footprint and Overall Height.....	33 <sup>1</sup> / <sub>2</sub> " Wide x 24 <sup>1</sup> / <sub>2</sub> " Deep and 49" High
Approximate Machine Weight .....	233 lbs.

# SAFETY FIRST!

**READ MANUAL BEFORE OPERATING MACHINE.  
FAILURE TO FOLLOW INSTRUCTIONS BELOW WILL  
RESULT IN PERSONAL INJURY**

## **DANGER**

Indicates an imminently hazardous situation which, if not avoided, **WILL** result in death or serious injury.

## **WARNING**

Indicates a potentially hazardous situation which, if not avoided, **COULD** result in death or serious injury.

## **CAUTION**

Indicates a potentially hazardous situation which, if not avoided, **MAY** result in minor or moderate injury. It may also be used to alert against unsafe practices.

## **NOTICE**

This symbol is used to alert the user to useful information about proper operation of the equipment.

1. **Thoroughly read the instruction manual before operating your machine.** Learn the applications, limitations and potential hazards of this machine. Keep manual in a safe, convenient place for future reference.
2. **Keep work area clean and well lighted.** Clutter and inadequate lighting invite potential hazards.
3. **Ground all tools.** If a machine is equipped with a three-prong plug, it must be plugged into a three-hole electrical outlet or grounded extension cord. If using an adapter to aid in accommodating a two-hole receptacle, ground using a screw to a known ground.
4. **Wear eye protection at all times.** Use safety glasses with side shields or safety goggles (that meet the national safety standards) while operating this machine.
5. **Avoid dangerous environments.** DO NOT operate this machine in wet or open flame environments. Airborne dust particles could cause an explosion and severe fire hazard.
6. **Ensure all guards are securely in place and in working condition.**
7. **Make sure switch is in the "OFF" position** before connecting power to machine.
8. **Keep work area clean and free of clutter, grease, etc.**
9. **Keep children and visitors away.** All visitors should be kept a safe distance away while operating unit.
10. **Childproof workshop** with padlocks, master switches or by removing switch keys.
11. **Disconnect machine** when cleaning, adjusting or servicing.

12. **Use this machine at the rate for which it was designed.** The machine will do a safer and better job if it is not forced.
13. **Use correct tool.** DO NOT force machine or attachment to do a job for which it was not designed.
14. **Wear proper apparel.** DO NOT wear loose clothing, neck ties, gloves, jewelry, etc.
15. **Remove adjusting keys and wrenches before starting the machine.** Make this a habit!
16. **Use proper extension cord.** When using an extension cord, make sure it is in good condition. Use extension cords 100' or less in length that are rated Hard Service (grade S) or better, and that have a conductor size of 16 AWG. A drop in line voltage, loss of power and overheating can result when using an undersized cord. The extension cord must have a ground wire and ground plug pin, as well.
17. **Keep proper footing and balance at all times,** and make sure you lock a mobile base in position.
18. **DO NOT leave machine operating and unattended**—wait until it comes to a complete stop before leaving the area.
19. **Perform machine maintenance and care.** Follow lubrication and accessory attachment instructions in the manual.
20. **Keep machine away from open flame.** Operating machines near pilot lights and/or open flames creates a high risk if dust is dispersed in the area. Dust particles and an ignition source may cause an explosion. DO NOT operate the machine in high risk areas, including but not limited to, those mentioned above.
21. **DO NOT use machine under the influence** of drugs or alcohol or if you are excessively tired.
22. **DO NOT let untrained people use the machine** if they are not supervised by an experienced operator.
23. **If at any time you are experiencing difficulties performing the intended operation, stop using the machine!** Then contact our service department or ask a qualified expert how the operation should be performed.
24. **Always be aware of switch location when moving items around the shop.** Magnetic switches and power switches can be accidentally turned on when they are bumped.

# Additional Safety Instructions for Planer/Moulders

	<p><b>⚠️ WARNING</b></p> <p>READ and understand this entire instruction manual before using this machine. Serious personal injury may occur if safety and operational information is not understood and followed.</p>
---	---

<p><b>⚠️ CAUTION</b></p>	<p>USE this and other machinery with caution and respect, and always consider safety first, as it applies to your individual working conditions. Remember, no list of safety guidelines can be complete, and every shop environment is different. Failure to follow guidelines can result in serious personal injury, damage to equipment or poor work results.</p>
--------------------------	---

1. Make sure moulding knives will not hit table before turning *ON* the machine.
2. Always make sure the Planer/Moulder is on firm ground and is stable before operating. Never use the Planer/Moulder if it wobbles or is unstable.
3. Always inspect the workpiece before running it through the Planer/Moulder. Stock with loose knots, nails, staples, dirt or other foreign objects should be rejected from use or corrected by eliminating the condition that makes it questionable.
4. Always make sure that all components of the Planer/Moulder are adjusted to their proper specifications before milling stock.
5. Always use the help of another person or some type of support fixture when milling long stock.
6. Never stand behind the workpiece when you are feeding it into the Planer/Moulder; the workpiece could possibly kick back and be thrown in the direction from which it came.
7. Never operate the Planer/Moulder if knives are dull or damaged. Sharp knives are safer and produce better final results.
8. Never process any material through the Planer/Moulder other than wood. This Planer/Moulder is designed for wood only!
9. Never attempt to free a stalled workpiece while the Planer/Moulder is connected to a power source.
10. Never reach inside the Planer/Moulder or open the top cover while the Planer/Moulder is connected to a power source.
11. Never plane wood that is less than 9" long or less than 1/4" thick.
12. Always wear hearing protection when operating the Planer/Moulder.



# Avoiding Potential Injuries



**Figure 1.** Correct body and hand positioning.



**Figure 2.** DO NOT operate without safety glasses/respirator!

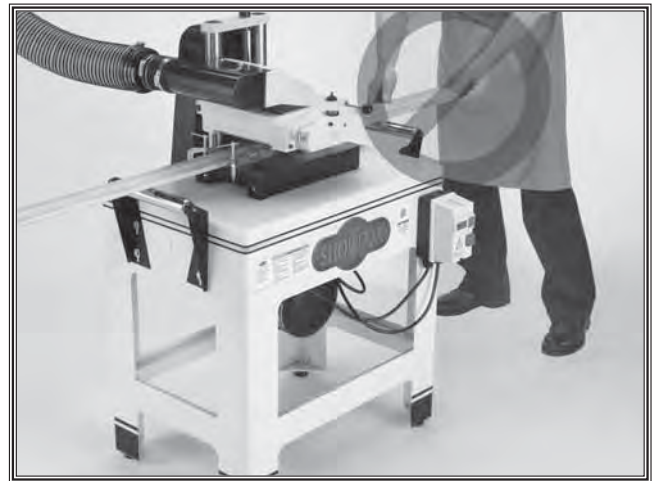

**Figure 3.** DO NOT stand behind workpiece!

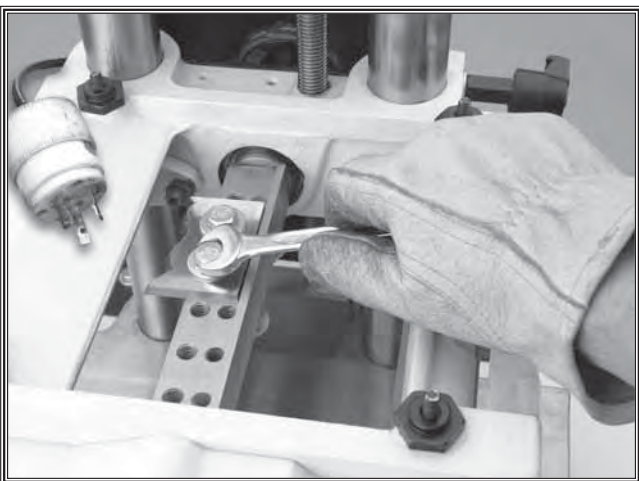

**Figure 4.** Disconnect power before performing maintenance!



**Figure 5.** DO NOT feed more than one board into the planer/moulder at a time!

# ELECTRICAL

## 220V Operation

The motor supplied with your new Planer/Moulder is rated at 2 H.P. and will draw approximately 12 amps during 220 volt operation. When choosing an outlet for this machine, use a NEMA 6-15 plug and outlet (**Figure 6**) with a 15 amp circuit breaker or fuse. Keep in mind that a circuit being used by other machines or tools at the same time will add to the total load being applied to the circuit. Add up the load ratings of all machines on the circuit. If this number exceeds the rating of the circuit breaker, fuse or wires, use a different circuit.

## Extension Cords

We do not recommend using an extension cord for 220V equipment. Instead, arrange the placement of your machinery and installed wiring to eliminate the need for extension cords. If you must use an extension cord, make sure it is rated Standard Service (grade S) and capable of handling a 15 amp load. The extension cord must always contain a ground wire and plug pin. Be sure to ask an electrician about the correct gauge to use with your desired cord length. Always repair or replace extension cords when they become worn or damaged.

## Grounding

This machine must be grounded! The electrical cord supplied with your Planer/Moulder does not come with a 220 volt plug. Install a NEMA 6-15 plug and outlet (See **Figure 6**) with a ground pin. If your outlet does not accommodate a ground pin, have a ground circuit installed by a qualified electrician or have an appropriate adapter installed and grounded properly. An adapter with a grounding wire does not guarantee the machine will be grounded. A ground source must be verified.

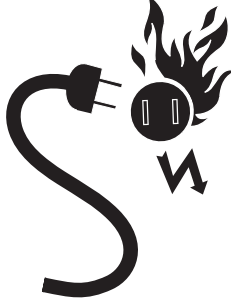

**⚠ WARNING**

Any electrical outlet and circuit that you plug your machine into must be grounded. Never remove the grounding pin from any plug, and always make sure all wiring to the machine is grounded before operating. Serious injury may occur if this warning is ignored!

**⚠ CAUTION**

DO NOT replace the circuit breaker with one rated at a higher amperage or damage to the circuit may occur.

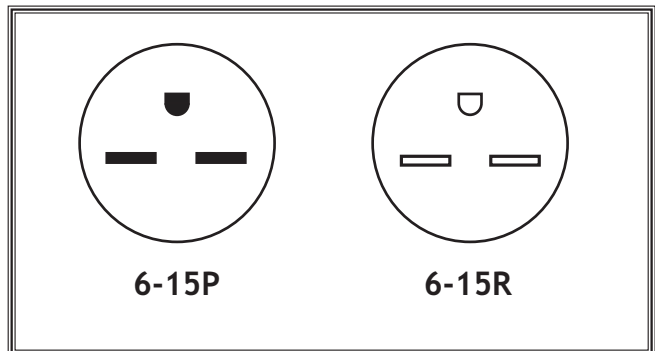

Figure 6. NEMA 6-15 plug and outlet.

# ASSEMBLY

## Overview

Inventory your package carefully with the list below. For missing parts, contact Woodstock International, Inc. at 360-734-3482 or by e-mail at: tech-support@shopfox.biz.

Most of your new Planer/Moulder has been factory assembled; however, some assembly and adjustments are required. Please take your time and try to be as accurate as possible when following each step. This care will provide you with better results when you are finished.

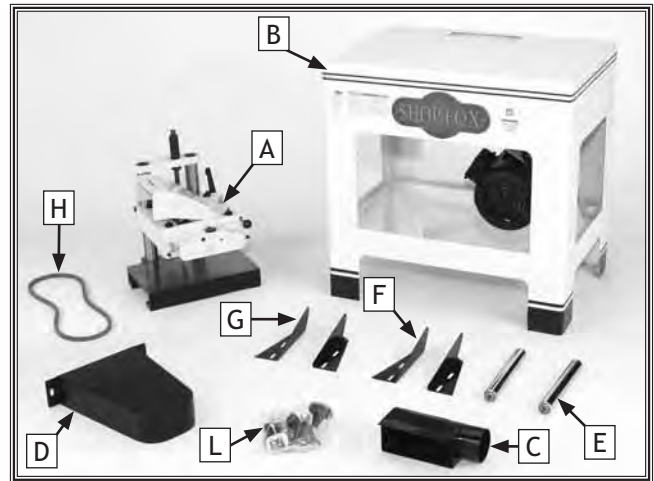
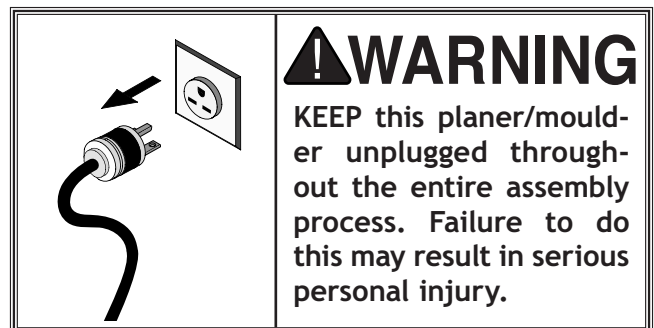

Figure 7. Parts inventory.

## Inventory

A.	Planer/Moulder Head.....	1
B.	Stand with Motor and Switch .....	1
C.	Dust Port.....	1
D.	Drive Belt Cover .....	1
E.	Extension Rollers.....	2
F.	Extension Roller Bracket (A) .....	2
G.	Extension Roller Bracket (B) .....	2
H.	Link Belt.....	1
I.	Depth Control Handle (Not Shown) .....	1
J.	Guide Rails (Not Shown) .....	2
K.	C-Clamps (Not Shown) .....	4
L.	Hardware Bag .....	1
	• Phlp Hd Screw 10-24 x 1/2".....	3
	• Hex Bolt 5/16"-18 x 3/4".....	10
	• Hex Bolt 5/16"-18 x 1-1/2" .....	4
	• Lock Washer 5/16".....	4
	• Flat Washer 5/16".....	24
	• Hex Nut 5/16" .....	14
	• Hex Nut 3/8".....	4
	• Rubber Foot.....	4
	• Hex Wrench 3mm .....	1
	• Hex Wrench 4mm .....	1
	• Open-End Wrench 12/14mm .....	1



ASSEMBLY

## Shop Preparation

- **Floor Load:** Your Planer/Moulder represents a large weight load in a small footprint. Some residential floors may require additional bracing to support both machine and operator.
- **Working Clearances:** Consider existing and anticipated needs, size of material to be processed through the machine, and space for auxiliary stands, work tables or other machinery when establishing a location for your Planer/Moulder.
- **Lighting:** Lighting should be bright enough to eliminate shadow and prevent eye strain.
- **Electrical:** Electrical circuits should be dedicated or large enough to handle amperage requirements. Outlets should be located near each machine, so power or extension cords are clear of high-traffic areas. Follow local electrical codes for proper installation of new lighting, outlets, or circuits.

## Cleaning Moulder

The table and other unpainted parts of your Planer/Moulder are coated with a waxy grease that protects them from corrosion during shipment. Clean this grease off with a solvent cleaner or citrus-based degreaser. **DO NOT** use chlorine-based solvents such as brake parts cleaner or acetone—if you happen to splash some onto a painted surface, you will ruin the finish.

	<p><b>⚠ WARNING</b> NEVER use gasoline or other petroleum-based solvents to clean with. Most have low flash points, which make them extremely flammable. A risk of explosion and burning exists if these products are used. Serious personal injury may occur if this warning is ignored!</p>
--	---

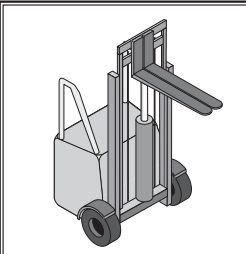
	<p><b>⚠ WARNING</b> USE helpers or power lifting equipment to lift this Planer/Moulder. Otherwise, serious personal injury may occur.</p>
---	---

	<p><b>⚠ WARNING</b> NEVER smoke while using solvents. A risk of explosion or fire exists and may result in serious personal injury.</p>
--	---

	<p><b>⚠ CAUTION</b> MAKE your shop "child safe." Ensure that your workplace is inaccessible to youngsters by closing and locking all entrances when you are away. NEVER allow untrained visitors in your shop when assembling, adjusting or operating equipment.</p>
---	--

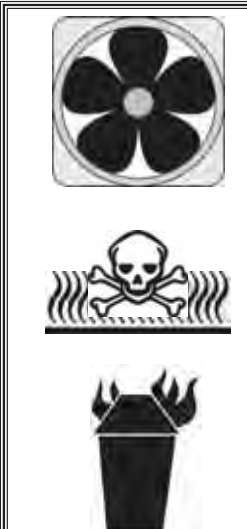
	<p><b>⚠ CAUTION</b> ALWAYS work in well-ventilated areas far from possible ignition sources when using solvents to clean machinery. Many solvents are toxic when inhaled or ingested. Use care when disposing of waste rags and towels to be sure they do not create fire or environmental hazards.</p>
--	---

## Rubber Feet

The rubber feet isolate machine vibration and are adjustable to compensate for uneven floors.

To install the rubber feet, do these steps:

1. Lay the stand on its side.
2. Thread a foot into the base of each leg.
3. Tilt the stand upright.
4. Place a level on the stand and adjust the feet up or down to level the stand. See **Figure 8**.
5. Secure the feet with  $\frac{3}{8}$ -16 hex nuts. See **Figure 8**.



**Figure 8.** Foot installation.

## Switch

The power switch is magnetically controlled and is equipped with an adjustable thermal protection switch. The switch is installed inside the stand for protection during shipping.

To install the switch, do these steps:

1. Remove the switch from the inside of the stand by removing the screws in the switch plate above and below the switch box. See **Figure 9**. DO NOT remove the switch from the switch plate.
2. Use the same screws to attach the switch plate onto the exterior of the stand as shown in **Figure 10**.

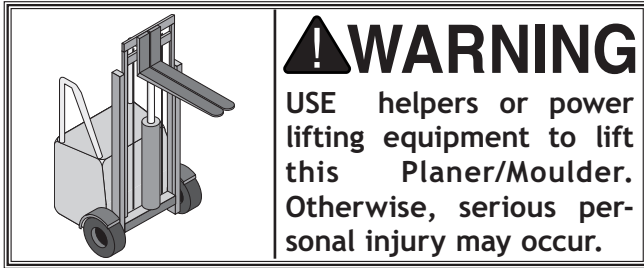

**Figure 9.** Switch removal.



**Figure 10.** Switch installation.

# Planer/Moulder Head



To mount the Planer/Moulder head, do these steps:

1. Lay two 2x4's on the table and lower the cutterhead to clamp the 2x4's in place as shown in **Figure 11**.
2. Using mechanical lifting equipment or helpers, lift with the 2x4's and set the planer/moulder head on the stand.
3. Secure the planer/moulder head to the stand with four  $\frac{5}{16}$ "-18 x 1 $\frac{1}{2}$ " hex bolts, flat washers, lock washers, and hex nuts.

## Drive Belt

The weight of the motor holds the drive belt tight. The drive belt then transfers power from the motor to the cutterhead.

To install the drive belt, do these steps:

1. Remove the shipping brace shown in **Figure 12**. Replace the motor mounting bolt after removing the brace.
2. Feed the belt through the slot in the base and over the cutterhead pulley with the arrows on the belt pointing the direction shown by the arrow in **Figure 13**.
3. Have an assistant swing the motor up and support it until the belt is in place.
4. Slide the drive belt around the motor pulley as shown in **Figure 13** and lower the motor to tension the drive belt.
6. If the drive belt is not vertical, loosen the setscrew in the upper pulley and slide the pulley in or out until the belt is vertical.



**Figure 11.** Suggested lifting procedure.

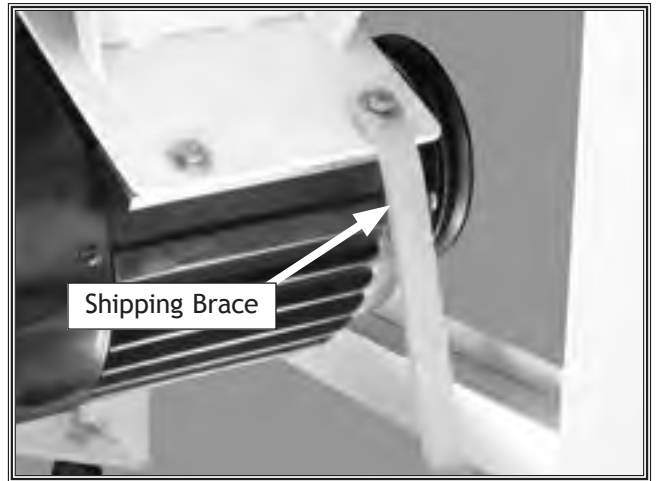

**Figure 12.** Shipping brace.



**Figure 13.** Installing the drive belt (Belt cover removed for clarity).

# Depth Control Handle

The depth control handle raises and lowers the cutterhead to change the cutting depth.

To mount the depth control handle, do these steps:

1. Align the setscrew in the depth control crank arm with the flat side of the shaft. See **Figure 14**.
2. Slide the depth control crank arm over the shaft and tighten the setscrew.



**Figure 14.** Installing the height handle.

# Extension Rollers

Extension rollers help eliminate snipe by supporting the workpiece as it moves through the planer/moulder. The extension roller assemblies are identical for both the infeed and the outfeed ends of the table.

To mount the extension rollers, do these steps:

1. Mount bracket "A" using the  $\frac{5}{16}$ "-18 x  $\frac{3}{4}$ " hex bolts, two washers on each bolt, and  $\frac{5}{16}$ " hex nuts. *Finger tighten the nuts.*
2. Slide the extension roller into the mounted bracket as shown in **Figure 15**.
3. Slide bracket "B" onto the other side of the extension roller, and attach the bracket to the stand. *Finger tighten the nuts.*
4. Place a straightedge across the table and the extension roller as shown in **Figure 16**.
5. Check the extension roller assemblies at multiple points to make sure they are flush with the table surface.
6. Tighten the mounting bolts to secure the extension bar in place. The top of the rollers should now be completely even with the top of the table. Double-check to make sure that the rollers did not move during the tightening process.

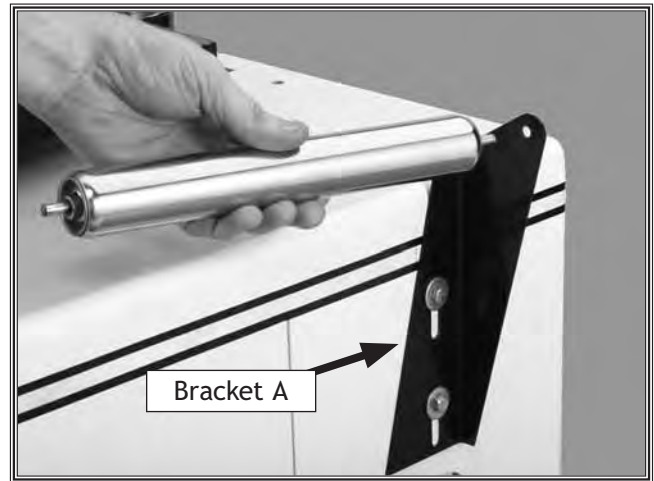

**Figure 15.** Installing the roller extension.

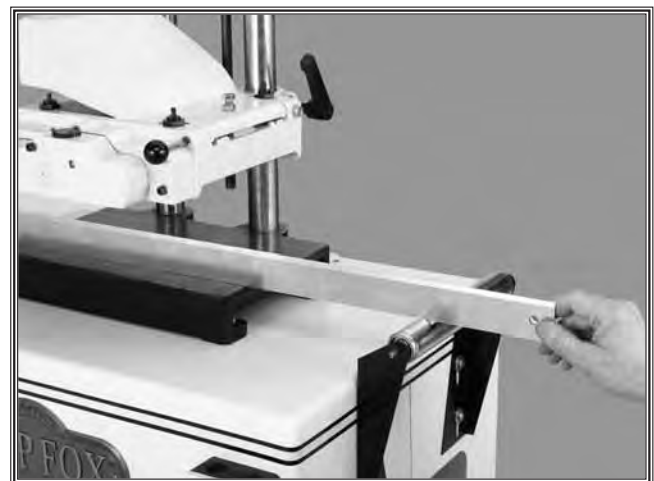

**Figure 16.** Extension roller-to-table alignment.

ASSEMBLY

## Belt Guard

The belt guards protect the user's hands and clothing from catching in the belt and pulleys.

To mount the belt guard, do these steps:

1. Align the holes in the belt guard with the two holes in the stand on either side of the belt. See **Figure 17**.
2. Attach the belt guard to the stand with two  $\frac{5}{16}$ "-18 x  $\frac{3}{4}$ " hex bolts with four washers and hex nuts.



**Figure 17.** Installing the belt guard.

## Dust Hood

Always use the dust hood with a dust collection system. Failure to use a dust collector will cause chips to clog the dust port and chips falling on the workpiece will mar the finish.

To mount the dust port, do these steps:

1. Slide the dust port over the chip deflector.
2. Attach the dust hood with three 10-24 x  $\frac{1}{2}$ " phillips head flange screws.



**Figure 18.** Installing the dust hood.

## Gear Box

The gear box reduces the cutterhead speed to drive the feed rollers at 6.8 FPM. Remove the shipping plugs before using the machine the first time. Check the gear oil level before each use.

Before using the first time, do these steps:

1. Remove the shipping plug from inside the oil filler and the #5-40 screw from the breather hole shown in **Figure 19**.

To check the oil level, do these steps:

1. Open the oil filler cover and check if the gear oil is even with the top of the oil filler horizontal tube.
2. Fill the gear box to the top of the oil filler horizontal tube with SAE 90 gear oil.

*Tip: Some oil seeping from the gear box is normal. Excessive leaking is usually caused by overfilling the gearbox.*

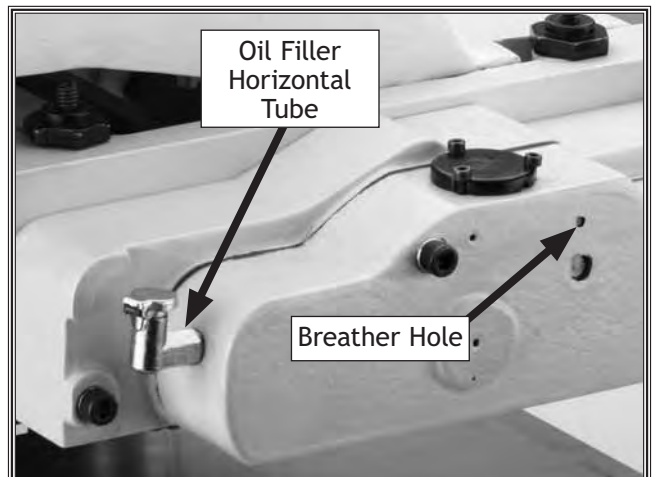

**Figure 19.** Gear box components.



# ADJUSTMENTS

## Planer/Moulder Overview

Take the time to familiarize yourself with the controls of your new Planer/Moulder. The controls will be frequently mentioned throughout this instruction manual.

As with all precision machinery, adjustments to the Planer/Moulder require very close tolerances. The adjustments described in this section have a basic factory setting. However, due to storage and shipping, it may be necessary for you to fine-tune these adjustments in the same order as presented in this manual, or your moulding results will be compromised. To achieve exact results, use a dial indicator or a Rotacator® (refer to **Planer/Moulder Accessories** on page 29).

Once you set up the Planer/Moulder correctly, you will enjoy stable machine settings and excellent planing results for a long time.

	<p><b>! CAUTION</b></p> <p>WEAR thick gloves and use extreme caution when working near cutting surfaces. Planer knives are dangerously sharp! Failure to exercise care while working near knives could result in severe injury.</p>
--	---

	<p><b>! WARNING</b></p> <p>NEVER connect power to the machine while performing adjustments. Failure to follow this warning may result in serious personal injury.</p>
--	---

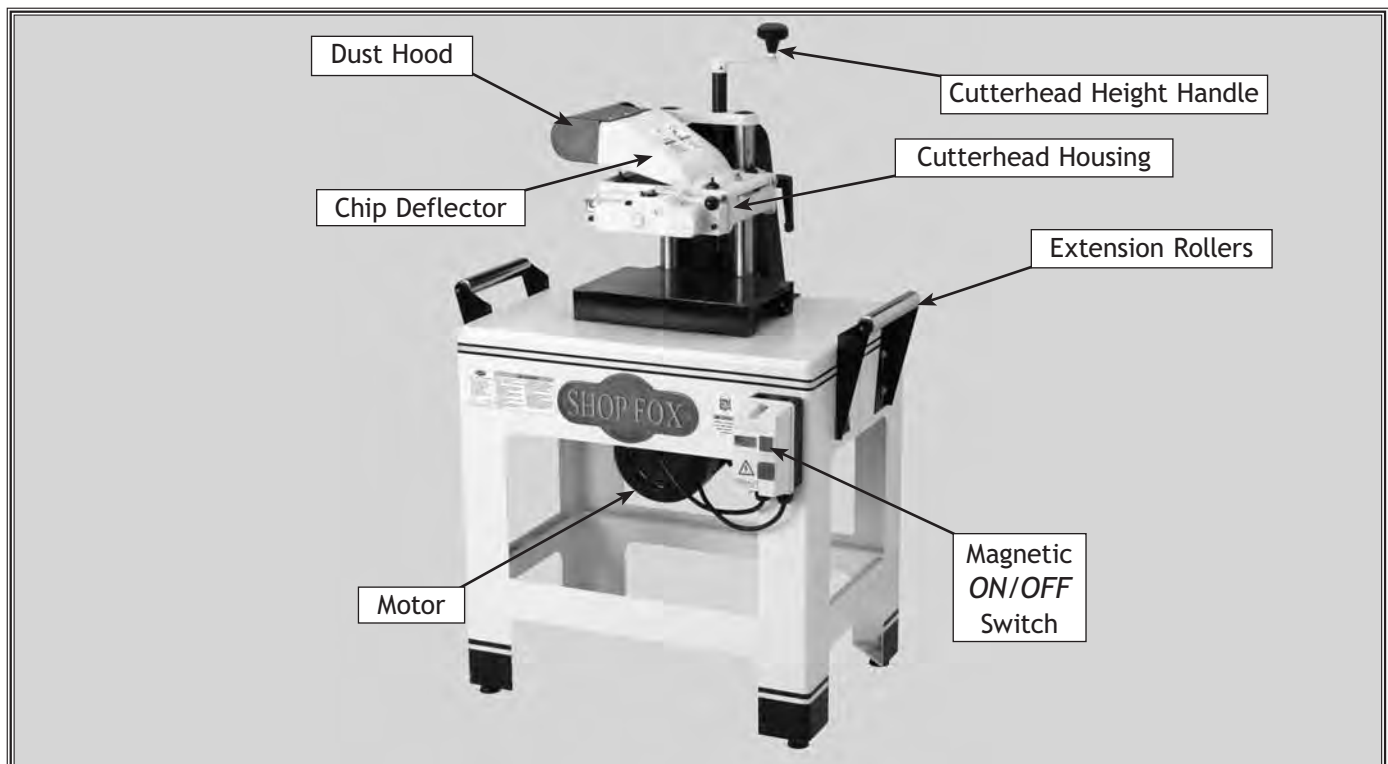

Figure 20. Machine controls.

# Test Run

Before turning the machine *ON* for the first time, read through the entire manual, complete the instructions given in the **Assembly** section, and follow all of the safety precautions. The purpose of this test run is to look for indications that the machine needs adjusting.

To test run, do these steps:

1. Make sure any tools used to assemble/adjust the machine are cleared away.
2. Raise the planer/moulder head to provide plenty of room for the safe operation of the feed rollers and the cutterhead.
3. Rotate the cutterhead manually to make sure the knives do not hit the table. **DO NOT** run any material through the machine at this time.
4. Plug in the power cord and press the **START** button. Remain near the switch in case you have to press the **STOP** button in an emergency. If strange noises or vibrations are heard, investigate and correct before operating the machine further.
5. Choose a scrap piece of lumber for a test piece and measure its thickness.
6. Loosen the cutterhead locking knob.
7. Turn the elevating handle  $\frac{1}{3}$  of a turn to set the cutterhead  $\frac{1}{32}$ " less than the stock thickness and lock the head. See **Figure 21**.
8. Turn the planer/moulder *ON* and feed the test piece through the machine.
9. Take note if the test piece slips, chatters, hangs up on the feed rollers, or if it moves to the side of the planer/moulder.
10. Turn the planer/moulder *OFF*.



**! WARNING**  
**THIS MACHINE** throws wood chips and sawdust. Wear safety glasses or a face shield during all operations.

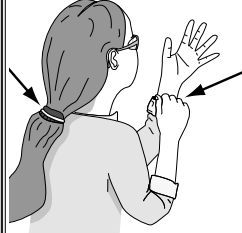

**! WARNING**  
**KEEP** loose clothing rolled up and out of the way of machinery and keep hair pulled back.



**! CAUTION**  
**THIS MACHINE** produces sawdust that may cause allergic reactions or respiratory problems. Wear a dust mask or respirator in addition to using a dust collector.

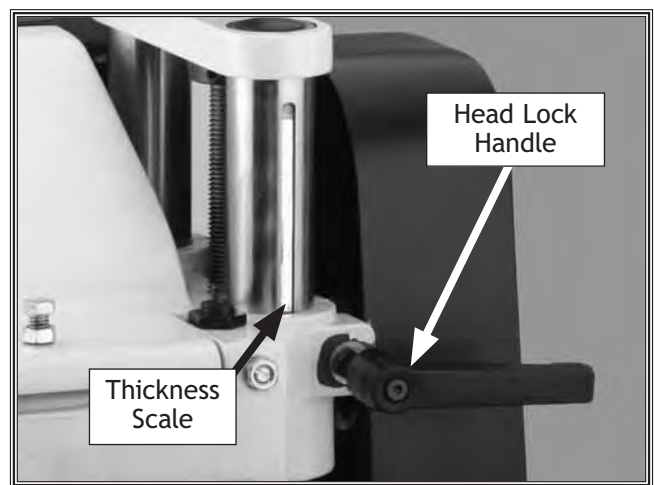

**Figure 21.** Thickness scale

ADJUSTMENTS

# Feed Roller-to-Table Alignment

The feed rollers must be aligned correctly with the table to maintain a smooth and straight feed.

To check the feed roller-to-table alignment, do these steps:

1. **UNPLUG THE PLANER/MOULDER!**
2. Lift the chip deflector, remove the pin and set the chip deflector to the side. See **Figure 22**.
3. Make a wood gauge block with parallel top and bottom surfaces or use a Rotacator (See **page 29**).
4. Place the block on the table, directly under one end of the infeed roller.
5. Lower the cutterhead housing so the infeed roller barely touches the gauge block. See **Figure 23**.
6. Without adjusting the infeed roller, slide the block of wood to the other end of the feed roller.
  - If the block of wood will not fit, move the head up until the block fits on the low end.
  - If the block is below the roller, measure the gap with a feeler gauge. If the difference is more than 0.002", then the feed roller needs to be adjusted.
7. Loosen the cap screw shown in **Figure 24**, then rotate the cam nut until the roller is parallel with the table.
8. Repeat **steps 6-7** until the roller is parallel, then tighten the cap screw.
9. Repeat **steps 4-8** with the outfeed roller.
10. Remove the gauge block and replace the chip deflector.

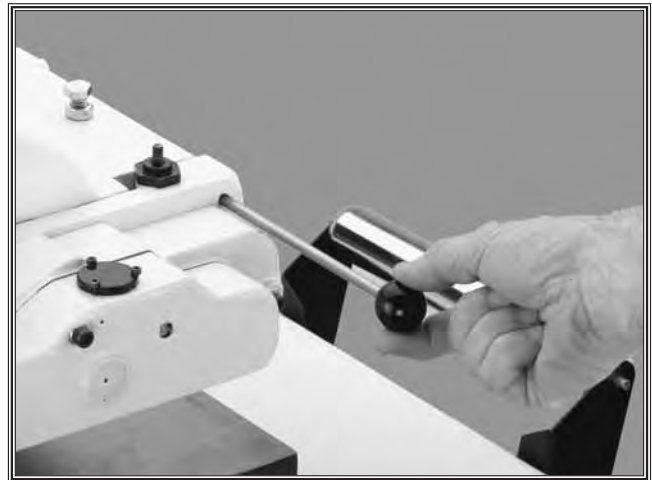

**Figure 22.** Chip deflector removal.



**Figure 23.** Gauge block.

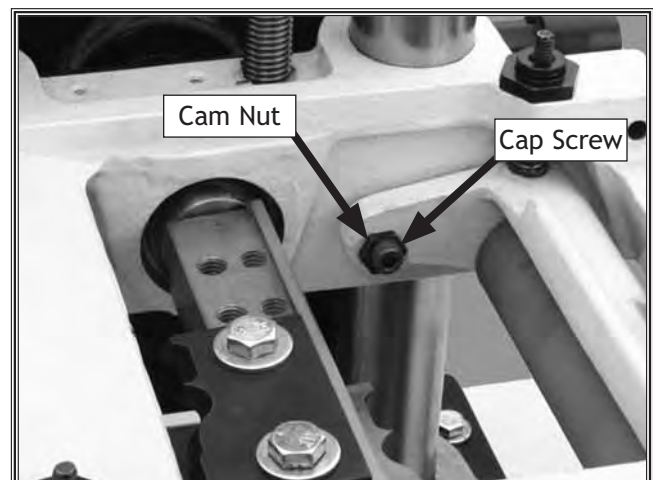

**Figure 24.** Feed roller adjustment.

# Feed Roller Spring Tension

Feed roller spring tension keeps the workpiece feeding into the Planer/Moulder without chatter or slipping.

The feed rollers usually work best at the highest pressure setting.

To adjust the feed roller spring tension, do these steps:

1. **UNPLUG THE PLANER/MOULDER!**
2. Tighten the four pressure screws and jam nuts shown in **Figure 25** until they are tight against the cutterhead housing to achieve the highest pressure.
3. If the workpiece hangs up on the infeed roller, loosen the jam nuts on both sides of the infeed side of the cutterhead housing.
4. Loosen the pressure screws equally on both sides of the infeed side of the cutterhead housing.
5. Tighten the jam nuts to lock the pressure screws in place.
6. If the workpiece hangs up on the outfeed roller, repeat **steps 3-5** for the outfeed pressure screws.

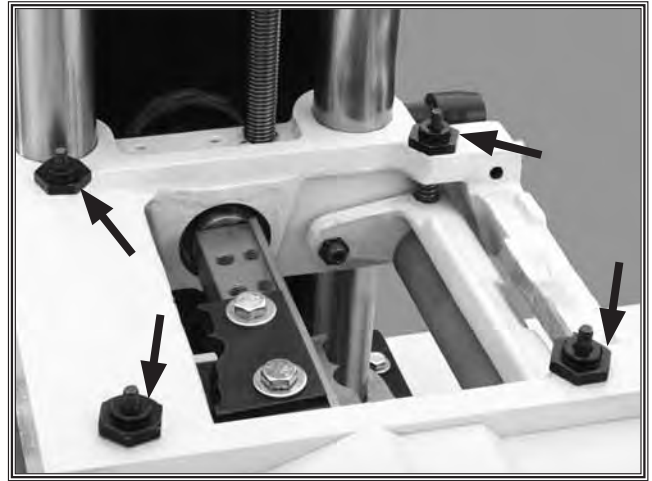

Figure 25. Spring tension adjustment.

# OPERATIONS

## Operational Tips

### NOTICE

**ALWAYS** lock down cutterhead lock knobs before planing or moulding. The cutterhead can move and create snipe at the ends of the boards.

- Carefully inspect any workpiece that you plan to run through the Planer/Moulder. Each workpiece must have at least one flat surface to slide along the Planer/Moulder table. To create a flat surface, pass the workpiece over a jointer first (see **Figure 26**). Defects such as twisting, loose knots or severe cracks may make the stock unusable.
- Only use clean lumber (see **Figure 27**). Scrape off all glue from joined boards before processing. Remove all dirt, nails, staples, imbedded gravel, etc. from any workpiece you plan on using. Metal or gravel in a workpiece will instantly damage the knives.
- Avoid processing a workpiece with a high moisture content. Wood with more than 20% moisture, or wood that has been exposed to rain or snow, will mill poorly and cause unnecessary wear on the knives and motor. Excess moisture may also cause rust or corrosion problems.
- Use **ONLY** natural wood fiber. Never process wood composites such as particle board, plywood or MDF. Never process laminates, Formica or other synthetic materials.
- Feed wood in the same direction as the grain. Never feed end-cut or end-grained lumber into the Planer/Moulder.

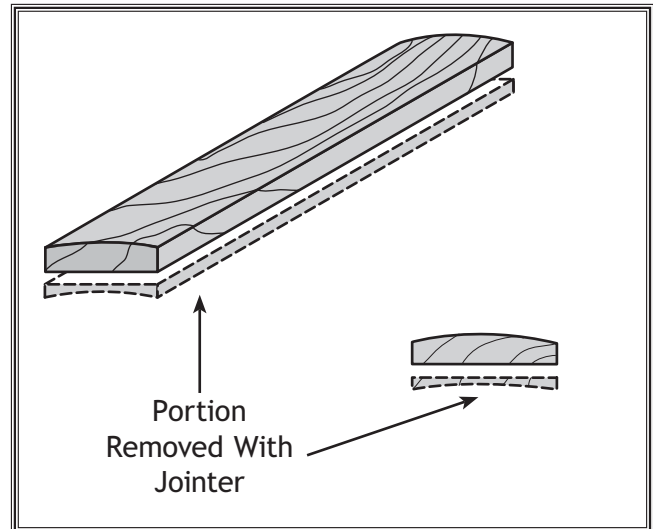

**Figure 26.** Face joint the concave side of cupped workpiece before milling.

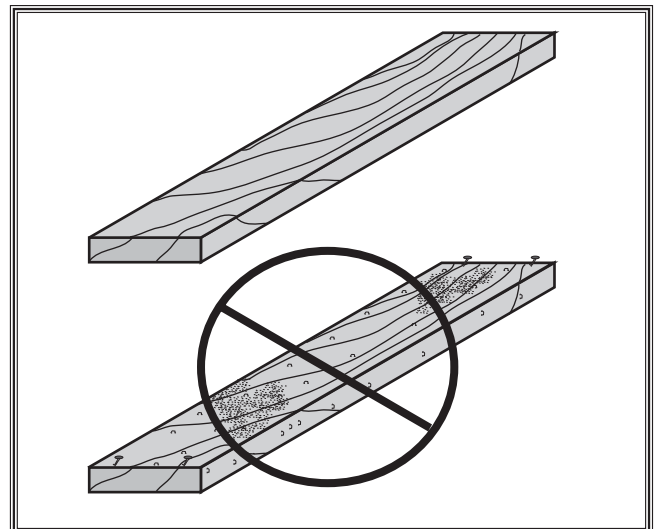

**Figure 27.** Only mill a clean workpiece.

# Moulding Knives



To install moulding knives, do these steps:

1. **UNPLUG THE PLANER/MOULDER!**
2. Remove the chip deflector.
3. Remove the knife lock bolts and knives shown in **Figure 29**.
4. Remove any dust and wood chips from the cutterhead lip.
5. Place the moulding knife against the cutterhead lip with the beveled side of the blade facing up as shown in **Figure 30**.
6. Line up the holes and insert the bolts.
7. Push the moulding knife against the cutterhead lip and towards the pulley side of the cutterhead. Tighten the bolts.
8. Make sure the knife did not move away from the cutterhead lip when tightened, then rotate the knife to the bottom.
9. Place a fence against the edge of the knife and use a square to line the fence up perpendicular to the edge of the table, and clamp it in place as shown in **Figure 31**.
10. Line up the holes and insert the bolts in the other moulding knife.
11. Rotate the cutterhead 180° and shift the other moulding knife until it also touches the fence. Tighten the remaining bolts.
12. Retighten the bolts and check that the moulding knives did not move away from the cutterhead lip when tightened.

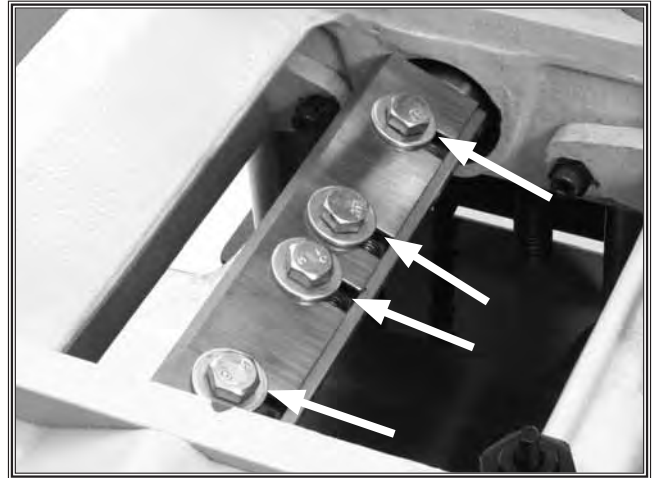

**Figure 29.** Knife lock bolts.



**Figure 30.** Moulder knife installation.



**Figure 31.** Knife alignment.

# Moulding Fences

The moulding fences keep the workpiece aligned with the knives for consistent results.

To align the moulding fences, do these steps:

1. **UNPLUG THE PLANER/MOULDER!**
2. Rotate a knife to the bottom and lower the cutterhead until the lowest section of the knife is just above the fence.
3. Align a fence to the work table by placing the base of a machinist square against the end of the work table, and slide the fence against the square as shown in **Figure 32**.
4. Move the machinist's square until the fence aligns with the edge of the moulding.
5. Clamp the fence to the work table with the included c-clamps.
6. Push the workpiece (cut to the finished moulding size) against the clamped fence and push the remaining fence against the workpiece. Clamp the fence in place.



**Figure 32.** Fences aligned to the work table.



**Figure 33.** Bedboard

# Bedboard

Build a bedboard for use with any knife that cuts the edge of the moulding. This will prevent the knives from hitting the table, breaking the knives, damaging the cutterhead, and possibly causing injury to the user. When using a bedboard the knives can be set slightly below the level of the workpiece for a clean edge cut.

To build a bedboard, do these steps:

1. **UNPLUG THE PLANER/MOULDER!**
2. Choose material that is  $\frac{1}{4}$ " -  $\frac{1}{2}$ " thick with a smooth surface to reduce friction between the bedboard and the workpiece.
3. Cut the bedboard material to the same size as the work table ( $8\frac{3}{4}$ " X 14").
4. Clamp the bedboard to the table with c-clamps (not included). See **Figure 33**.

# Moulding

## ⚠️ WARNING

Removing more than 1/8" off the overall width when moulding can break the knives, resulting in serious damage or injury.

To perform moulding operations, do these steps:

1. Plane stock to the final thickness.
2. Cut to the final width if only the face is profiled. Cut the width to less than 1/8" of the final width if the edges are trimmed by the knives. Tip: *Mouldings may need to have the profile roughed out with a dado blade on a table saw if the profile is deep.*
3. Set the fences to the correct width.



Figure 34. Thickness scale.

## ⚠️ WARNING

This machine throws wood chips and sawdust. **WEAR** safety glasses or a face shield during all operations.

## ⚠️ WARNING

This machine can cause kickback. **DO NOT** stand directly behind the planer/moulder while operating machine.

## ⚠️ WARNING

Kickback can occur if boards are not moulded in a single pass through this machine.



Figure 35. Correct moulding technique.

4. Lock the planer/moulder cutterhead in place at the final thickness as shown in **Figure 34**. Cut the profile in a single pass to keep the feed rollers from slipping which allows the workpiece to kickback.
5. Turn the planer/moulder **ON**. Feed the workpiece into the machine as shown in **Figure 35**. Support the board until half of it has been fed into the machine.
6. Walk around the machine to support the board on the outfeed side, or use outfeed rollers, or a partner.



# Replacing Planer Knives

	<p><b>⚠ CAUTION</b></p> <p>WEAR thick gloves and use extreme caution when working near cutting surfaces. Planer knives are dangerously sharp! Failure to exercise care while working near knives could result in severe injury.</p>
--	---

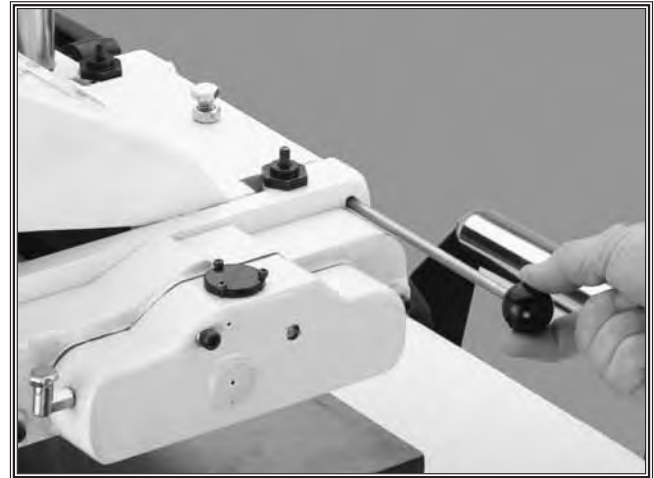

Figure 36. Removing the chip deflector.

To install the planer knives, do these steps:

1. **UNPLUG THE PLANER/MOULDER!**
2. Pull the pin indicated in **Figure 36** and remove the chip deflector.
3. Remove the knife lock bolts and knives as shown in **Figure 37**.
4. Remove any dust and wood chips from the cutterhead.
5. Place the new planer blade against the cutterhead lip with the beveled side of the blade facing up as shown in **Figure 37**.
6. Line up the holes in the planer blade and the cutterhead, and screw the bolts into the holes.
7. Push the planer blade against the cutterhead lip and tighten the bolts.
8. Make sure that the planer blade did not move away from the cutterhead lip during the tightening process.
9. Rotate the cutterhead and repeat **steps 2-5** for the other planer blade.

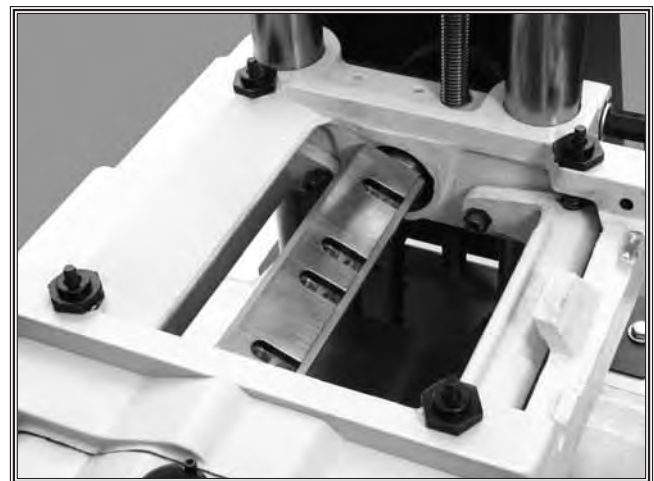

Figure 37. Installing a planer blade.

# Planing

Planing only reduces the thickness of a workpiece. Use a jointer to remove warping, cupping, and twisting before planing.

To perform planing operations, do these steps:

1. Measure the thickest workpiece that will be planed. Use calipers for best results.
2. Loosen the planer/moulder head locking knob.
3. Set the cutterhead  $\frac{1}{32}$ " less than the thickness measured in **Step 1** by turning the elevating handle  $\frac{1}{3}$  of a turn. Lock the cutterhead in place before planing.



Figure 38. Planing.

	<p><b>! WARNING</b></p> <p>This machine can cause kick-back. <b>DO NOT</b> stand directly behind the planer/moulder while operating machine.</p>
--	--

	<p><b>! WARNING</b></p> <p>This machine throws wood chips and sawdust. <b>WEAR</b> safety glasses or a face shield during all operations.</p>
--	---

4. Turn the planer/moulder ON. Stand to the side and feed a test piece into the planer/moulder. Tip: *Always plane WITH the grain of the wood to prevent chipping.*
5. Support the infeed end of the board until half of the board has been fed into the planer/moulder, then walk around to the outfeed side, or support the other end of the board with outfeed rollers, or use a partner.
6. Remove additional material from the workpiece by lowering the cutterhead and feeding the workpiece through the planer/moulder again.

# Planing Tips

- DO NOT plane more than one piece at a time.
- Remove less material on each pass for a smoother finish.
- When possible, plane equal amounts on each side of the board to reduce the chance of twisting or cupping.
- Feed stock end to end to reduce snipe.
- Planing is more difficult in hard species of wood and may require several shallow cuts to reach the desired thickness. **Figure 39** lists the hardness of many common woods based on shear strength. The shear strength of hard wood is greater than the shear strength of soft woods.
- Planing ability is also effected by the width of the workpiece. A wide workpiece will require several shallow passes through the Planer/Moulder vs. a narrow workpiece which may be planed to the desired depth in one pass.

	TYPE .....	SHEAR (PSI)
<b>HARDEST</b>  <b>SOFTEST</b>	Black Locust.....	2,480
	Sugar Maple .....	2,330
	Pecan Hickory.....	2,080
	White Oak .....	2,000
	White Ash.....	1,950
	Black Cherry .....	1,700
	American Elm .....	1,510
	Black Walnut .....	1,410
	Red Alder .....	1,370
	Basswood .....	1,280
	Cottonwood .....	1,160
	Western Larch .....	1,150
	Tamarack .....	1,130
	Douglas Fir .....	1,080
	Alaska Cedar .....	1,050
	Sitka Spruce .....	1,000
	Sugar Pine .....	980
Cypress.....	940	
Redwood (OG) .....	930	
Red Cedar .....	860	
White Pine.....	850	
Balsam Fir .....	710	

Figure 39. Wood density.

# MAINTENANCE

## General

Regular periodic maintenance on your Planer/Moulder will ensure its optimum performance. Make a habit of inspecting your Planer/Moulder each time you use it.

Check for the following conditions and repair or replace when necessary:

- Loose knife, motor, or machine bolts.
- Worn switch.
- Worn or damaged cords and plugs.
- Damaged link belt.
- Any other condition that could hamper the safe operation of this machine.

## Cleaning

Wear safety glasses and a respirator when using compressed air to blow-off dust build-up. Dust build-up around the motor can lead to motor failure.

Occasionally it will become necessary to clean the internal parts with more than compressed air. To do this, remove the covers and clean the internal parts with a citrus cleaner or mineral spirits and a stiff wire brush or steel wool. **DO NOT USE WATER—WATER WILL RUST CAST IRON.** Make sure the internal workings are dry before using the Planer/Moulder again. If any essential lubrication is removed during cleaning, re-lubricate those areas.

## Table

The table can be kept rust-free with regular applications of products like G96® Gun Treatment, or Slipit®. For long term storage, you may want to consider a product like Boeshield® T-9.

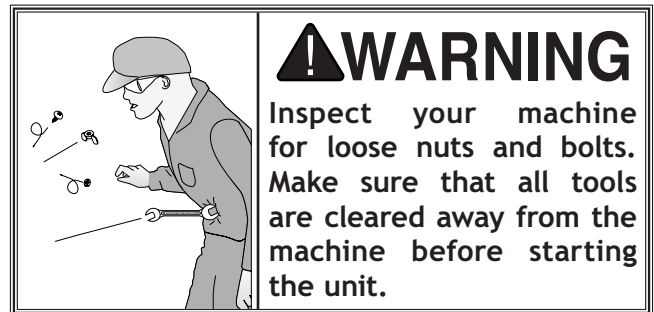
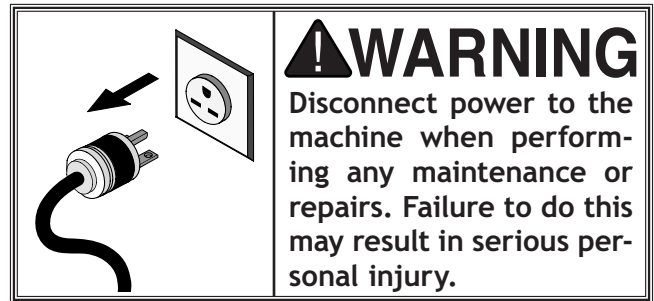

# Lubrication

Since all bearings are sealed and permanently lubricated, leave them alone until they need to be replaced. DO NOT lubricate them. However, your Planer/Moulder does need lubrication in the following listed places, depending on heavy use and the shop environment:

- **Columns and Lead Screws** – Lubricate columns as needed with light oil to prevent rust, and lubricate the four lead screws with a general purpose grease to prevent rust and maintain smooth operation.
- **Gear Box** – Drain the gear box after the first 30 hours of operation. **Figure 40** shows the gear box drain and oil filler tube. Refill with SAE 90 gear oil. The oil level should reach the top of the horizontal tube of the oil filler. After the initial change, inspect fluid before using the machine and change yearly. If your Planer/Moulder receives heavy use, change the gear oil more frequently. *Tip: Some oil seeping from the gear box is normal. Excessive leaking is usually caused by overfilling the gearbox.*
- **Drive Chains** – Inspect and lubricate the drive chains every six months. Check the sprockets, the chain, and the master links during inspection. Use a general purpose grease to lubricate the chain.
- **Feed Roller Tension Guides** –Lubricate all four feed roller tension guides with two drops of oil before daily start-up. **Figure 41** shows the lubrication points for the feed rollers. DO NOT lubricate more than two drops or the excess oil will end up on the floor.

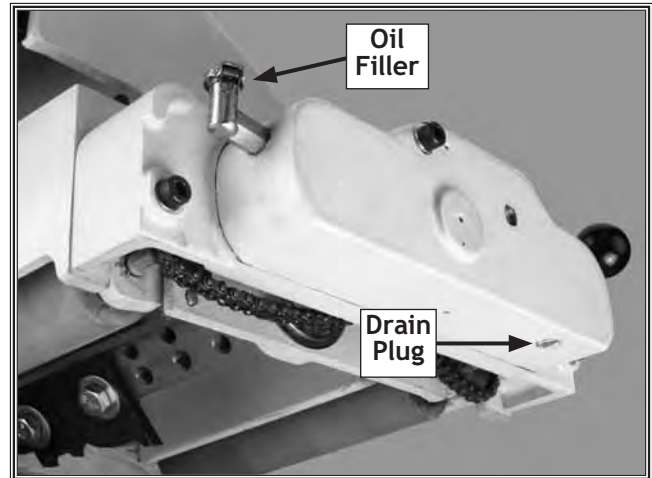

Figure 40. Gear box drain and oil filler tube.

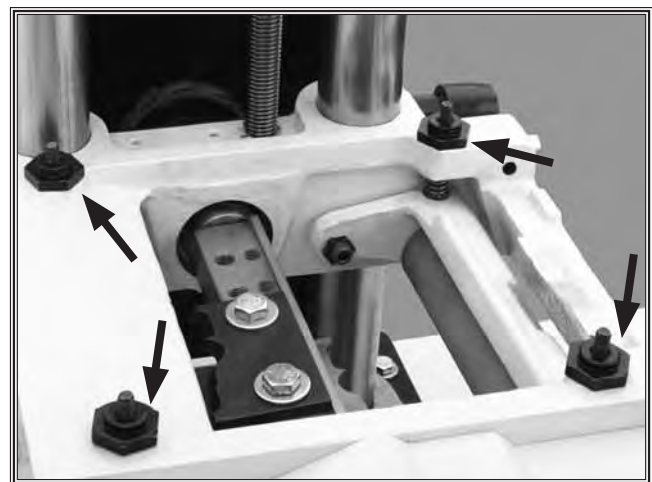

Figure 41. Feed roller tension guide lubrication points.

# Troubleshooting

This section covers the most common Planer/Moulder problems. DO NOT make any adjustments until the Planer/Moulder is unplugged and moving parts have come to a complete stop.

SYMPTOM	POSSIBLE CAUSE	CORRECTIVE ACTION
Motor will not start.	<ol style="list-style-type: none"> <li>1. Low voltage.</li> <li>2. Open circuit in motor or loose connections.</li> <li>3. Faulty start capacitor.</li> </ol>	<ol style="list-style-type: none"> <li>1. Check power supply for proper voltage.</li> <li>2. Inspect all lead connections on motor and magnetic switch for loose or open connections.</li> <li>3. Replace start capacitor.</li> </ol>
Fuses or circuit breakers trip open.	<ol style="list-style-type: none"> <li>1. Short circuit in line cord or plug.</li> <li>2. Short circuit in motor or loose connections.</li> <li>3. Incorrect fuses or circuit breakers in power supply.</li> </ol>	<ol style="list-style-type: none"> <li>1. Inspect cord or plug for damaged insulation and shorted wires and replace extension cord.</li> <li>2. Inspect all connections on motor for loose or shorted terminals or worn insulation.</li> <li>3. Install correct fuses or circuit breakers.</li> </ol>
Motor overheats.	<ol style="list-style-type: none"> <li>1. Motor overloaded.</li> <li>2. Air circulation through the motor restricted.</li> </ol>	<ol style="list-style-type: none"> <li>1. Reduce load on motor.</li> <li>2. Clean out motor to provide normal air circulation.</li> </ol>
Motor automatically shuts off (possibly resulting in blown fuse or tripped circuit breaker in Planer/Moulder magnetic switch box, or in power supply circuit).	<ol style="list-style-type: none"> <li>1. Thermal Protection Circuit Breaker amperage is set too low.</li> <li>2. Short circuit in motor or loose connections.</li> <li>3. Low power supply voltage.</li> <li>4. Incorrect fuses/circuit breakers.</li> </ol>	<ol style="list-style-type: none"> <li>1. Unplug machine, open magnetic switch cover, turn amperage dial on Thermal Protection Circuit Breaker to a higher amperage setting.</li> <li>2. Inspect connections on motor for loose or shorted terminals or worn insulation.</li> <li>3. Correct the low voltage condition with a qualified electrician.</li> <li>4. Install correct fuses or circuit breakers.</li> </ol>
Loud, repetitious noise coming from machine.	<ol style="list-style-type: none"> <li>1. Pulley setscrews or keys are missing or loose.</li> <li>2. Motor fan is hitting the cover.</li> </ol>	<ol style="list-style-type: none"> <li>1. Inspect keys and setscrews. Replace or tighten if necessary.</li> <li>2. Tighten fan or shim cover, or replace items.</li> </ol>
Machine is loud when cutting. Overheats or bogs down in the cut.	<ol style="list-style-type: none"> <li>1. Excessive depth of cut.</li> <li>2. Wet lumber.</li> <li>3. Knives are dull.</li> </ol>	<ol style="list-style-type: none"> <li>1. Decrease depth of cut.</li> <li>2. Use lumber with less than 20% moisture content.</li> <li>3. Sharpen knives.</li> </ol>
Moulder/planer head moves while cutting.	<ol style="list-style-type: none"> <li>1. Moulder/planer head is loose on columns.</li> <li>2. Knives dull.</li> </ol>	<ol style="list-style-type: none"> <li>1. Lock down cutterhead casting lock knobs before planing.</li> <li>2. Replace knives.</li> </ol>
Cannot control snipe.	<ol style="list-style-type: none"> <li>1. Long or heavy board sags as it enters and exits.</li> <li>2. Infeed/outfeed rollers are low.</li> <li>3. Stock is not long enough.</li> </ol>	<ol style="list-style-type: none"> <li>1. Lift up on unsupported end of board as it enters and exits cutterhead.</li> <li>2. Raise the feed rollers to <math>\frac{1}{32}</math>" above the level of the work table</li> <li>3. Feed stock end to end.</li> </ol>
Chipped grain occurs when planing or moulding.	<ol style="list-style-type: none"> <li>1. Planing against the grain.</li> <li>2. Dull knives.</li> </ol>	<ol style="list-style-type: none"> <li>1. Flip the board and plane the other side.</li> <li>2. Sharpen or replace knives.</li> </ol>
Fuzzy grain occurs when planing or moulding.	<ol style="list-style-type: none"> <li>1. Lumber has high moisture content.</li> <li>2. Dull knives.</li> </ol>	<ol style="list-style-type: none"> <li>1. If moisture content is higher than 20%, sticker and allow to dry.</li> <li>2. Sharpen or replace knives.</li> </ol>
Workpiece will not feed through the machine.	<ol style="list-style-type: none"> <li>1. Moulder/planer head is set too high.</li> <li>2. Workpiece is binding in the guides.</li> <li>3. Feed roller spring pressure is set incorrectly.</li> <li>4. Work table is rusty, nicked, or dirty.</li> </ol>	<ol style="list-style-type: none"> <li>1. Lower the moulder/planer head to the thickness of the workpiece.</li> <li>2. Plane all of the workpieces to a consistent width.</li> <li>3. Change feed roller spring pressure as described on page 18.</li> <li>4. Clean work table surface and apply a rust inhibiting and friction reducing product such as SLIPIT®.</li> </ol>

# Planer/Moulder Accessories

The following Planer/Moulder accessories may be available through your local Woodstock International Inc. Dealer. If you do not have a dealer in your area, these products are also available through online dealers. Please call or e-mail Woodstock International Inc. Customer Service to get a current listing of dealers at: 1-800-840-8420 or at [sales@woodstockint.com](mailto:sales@woodstockint.com).

**The W3393 SHOP FOX® Elliptical Jig** allows you to create curved mouldings on the W1693 Planer/Moulder. With the addition of this simple jig you can make mouldings for circular windows and arch topped doorways.



**The D2058 SHOP FOX® Super Heavy-Duty Mobile Base** supports your Planer/Moulder so you can move it easily and lock it in place. Designed for long term and frequent moving of heavy machinery. All SHOP FOX® Adjustable Mobile Bases are strong enough to move heavy machines on a continual basis. The stands are adjustable to fit a variety of machines and can be leveled without the use of shims or tools.

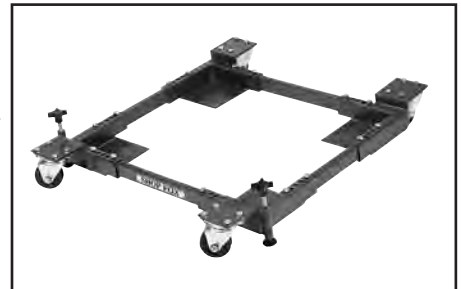

**The SHOP FOX® Heavy-Duty Roller Stands and Roller Tables** make your Planer/Moulder safer and easier to use. All models feature convenient hand knobs for fast height adjustment and offer rigid steel construction. These stands are invaluable for supporting work on Planer/Moulders and to reduce snipe at the ends of long boards due to infeed and outfeed alignment issues.



**The D2271 SHOP FOX® Heavy-Duty Roller Table** is a versatile roller table wherever you need extra workpiece support for up to a 1,000 lb. capacity. It features all-steel welded construction and it measures 19" x 65" long. The roller table also comes with 9 ball bearing rollers with four independently adjustable legs for any leveling requirement. The roller table is also adjustable in height from 26<sup>3</sup>/<sub>8</sub>" to 44<sup>1</sup>/<sub>8</sub>".



**The W1218 Rotacator®** makes a Planer/Moulder setup process easier and more accurate for adjusting the feed rollers and aligning cutterhead knives. This tool is a rotating dial indicator on a magnetic base. Shown to the right, this handy device measures table-to-cutterhead alignment and the table roller height. The Rotacator® allows you to set your feed rollers to within 0.001" from being parallel with the table.



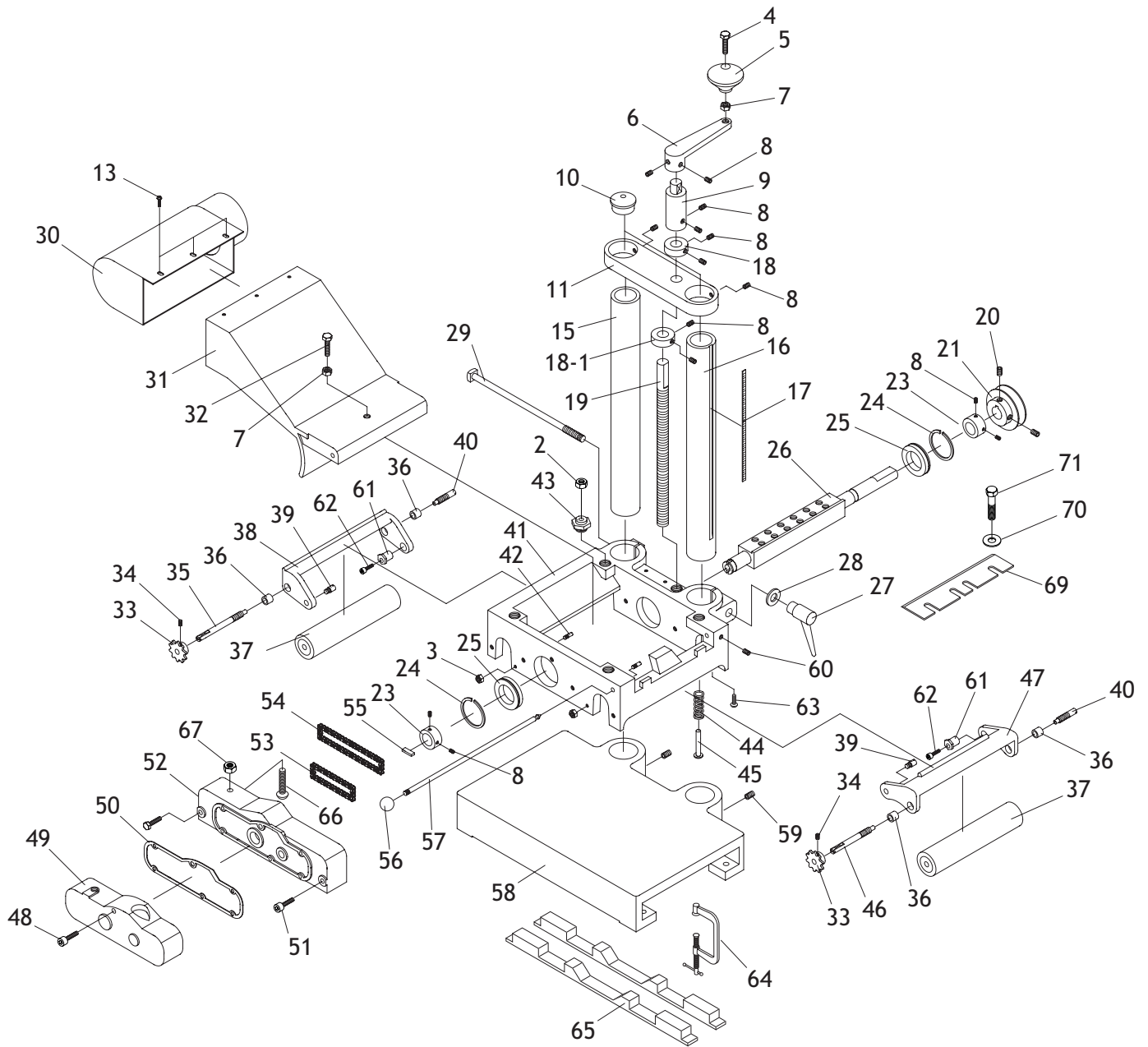



REF	PART #	DESCRIPTION
2	XPNO1	HEX NUT 1/2"-20 UNF
3	XPNO5	HEX NUT 1/4"-20
4	XPB25	HEX BOLT 3/8"-16 X 1 3/4"
5	X1693005	DEPTH CONTROL KNOB
6	X1693006	DEPTH CONTROL CRANK ARM
7	XPNO8	HEX NUT 3/8"-16
8	XPSS11	SET SCREW 1/4"-20 X 1/4"
9	X1693009	DEPTH CONTROL SHAFT
10	X1693010	DUST COVER
11	X1693011	TOP BRACE BAR
13	XPFB05	FLANGE BOLT 10-24 X 1/2"
15	X1693015	TUBE A
16	X1693016	TUBE B
17	X1693017	SCALE
18	X1693018	OUTER COLLAR
18-1	X1693018	INNER COLLAR
19	X1693019	ELEVATING SCREW
20	XPSS02	SET SCREW 5/16"-18 X 3/8"
21	X1693021	CUTTERHEAD PULLEY
23	X1693023	COLLAR
24	X1693024	EXT RETAINING RING 47MM
25	XP6204	BALL BEARING 6204ZZ
26	X1693026	CUTTERHEAD
27	X1693027	LOCK HANDLE (3/8" FEMALE)
28	XPW02	FLAT WASHER 3/8"
29	X1693029	HD LOCK BOLT 3/8" X 8-1/2"
30	X1693030	DUST HOOD
31	X1693031	CHIP DEFLECTOR
32	XPB18	HEX BOLT 3/8"-16 X 1"
33	X1693033	FEED ROLLER SPROCKET
34	XPSS29	SET SCREW 10-24 X 1/4"
35	X1693035	THREADED DRIVE SHAFT
36	X1693036	BUSHING
37	X1693037	RUBBER FEED ROLLER

REF	PART #	DESCRIPTION
38	X1693038	OUTFEED SWING ARM
39	X1693039	PIVOT PIN
40	X1693040	THREADED DRIVE SHAFT
41	X1693041	CUTTERHEAD HOUSING
42	X1693042	SWING ARM STOP PIN
43	X1693043	ROLLER PRESSURE SCREW
44	X1693044	SPRING
45	X1693045	ROLLER PRESSURE PIN
46	X1693046	THREADED DRIVE SHAFT
47	X1693047	INFEED SWING ARM
48	X1693048	CAP SCREW 1/4"-20 X 3 1/2"
49	X1693049	GEAR BOX HOUSING
50	X1693050	GEAR BOX GASKET
51	XPSB18	CAP SCREW 1/4"-20 X 1 3/4"
52	X1693052	CHAIN GUARD
53	X1693053	ROLLER CHAIN (INFEED)
54	X1693054	ROLLER CHAIN (OUTFEED)
55	X1693055	SPECIAL KEY
56	X1693056	KNOB (FEMALE)
57	X1693057	CHIP DEFLECTOR AXIS PIN
58	X1693058	BASE
59	XPSS09	SET SCREW 3/8"-16 X 1/2"
60	X1693060	BALL PLUNGER 3/8"-16 X 20"
61	X1693061	CAM NUT
62	XPSB06	CAP SCREW 1/4"-20 X 1"
63	XPS07	PHLP HD SCR 1/4"-20 X 3/8"
64	X1693064	C-CLAMP
65	X1693065	GUIDE RAIL
66	X1693066	CHAIN GUIDE
67	XPNO2	HEX NUT 5/16"-18
68	XPRP72M	ROLL PIN 3 X 15
69	X1693069	PLANER KNIVES
70	XPW02	FLAT WASHER 3/8"
71	XPB21	HEX BOLT 3/8"-16 X 3/4"

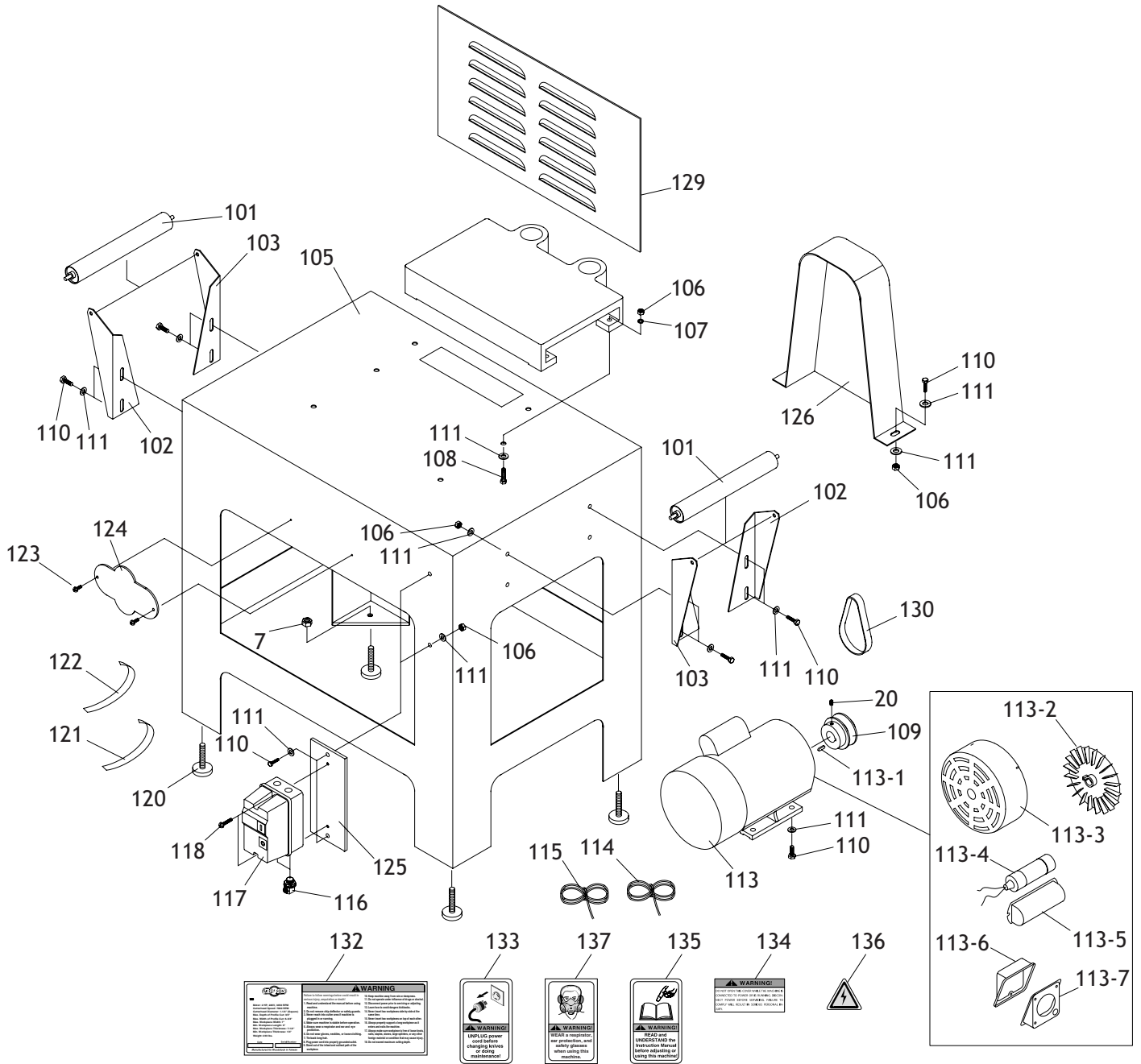

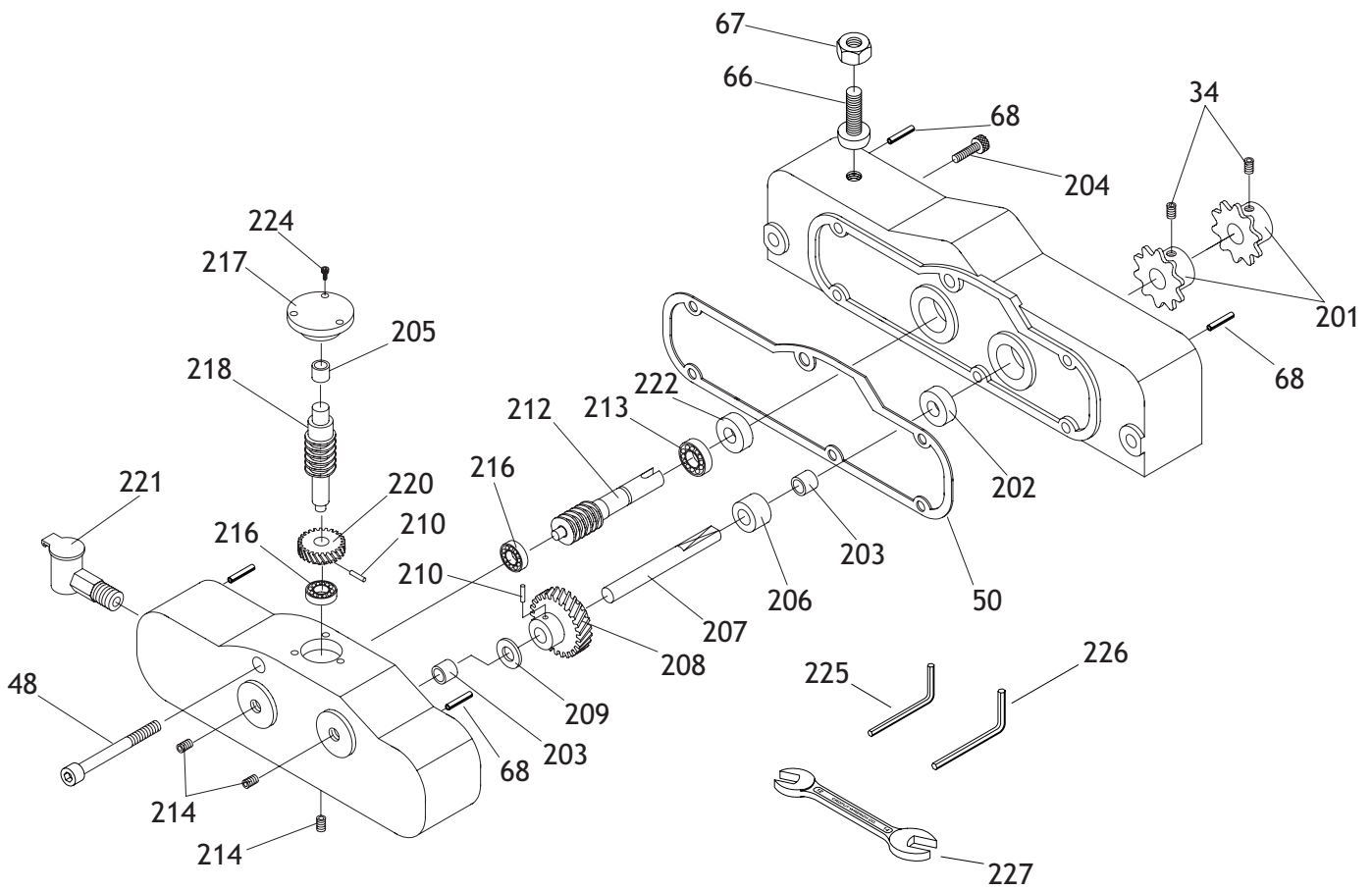

REF	PART #	DESCRIPTION
101	X1693101	EXTENSION ROLLER
102	X1693102	RIGHT BRACKET
103	X1693103	LEFT BRACKET
105	X1693105	STAND
106	XPN02	HEX NUT 5/16"-18
107	XPLW01	LOCK WASHER 5/16"
108	XPB11	HEX BOLT 5/16"-18 X 1 1/2"
109	X1693109	MOTOR PULLEY
110	XPB86	HEX BOLT 5/16"-18 X 3/4"
111	XPW07	FLAT WASHER 5/16"
113	X1693113	MOTOR 2 H.P.
113-1	XPB23M	KEY 5 X 5 X 25
113-2	X1693113-2	FAN
113-3	X1693113-3	FAN COVER
113-4	XPC400A	CAPACITOR 400MFD 125V
113-5	X1693113-5	CAPACITOR COVER
113-6	X1693113-6	WIRING BOX BASE
113-7	X1693113-7	WIRING BOX COVER
114	X1693114	POWER CORD
115	X1693115	MOTOR CORD
116	X1693116	STRAIN RELIEF
117	X1693117	SWITCH
118	XPS06	PHLP HD SCR 10-24 X 3/8"
120	X1693120	FOOT
121	X1693121	BLACK COLOR-STRIPE
122	X1693122	CREAM COLOR-STRIPE
123	XPS81	PHLPS HD SCR #4-40 X 3/8"
124	XPLOGO1	SF LOGO 5 1/8 X 11 1/8
125	X1693125	SWITCH BRACKET
126	X1693126	PULLEY COVER
129	X1693129	VENTILATED REAR PANEL

REF	PART #	DESCRIPTION
130	X1693130	LINK BELT 1/2" x 48"
132	X1693132	W1693 ID LABEL
133	X1693133	UNPLUG POWER LABEL
134	X1693134	COVER WARNING LABEL
135	X1693135	READ MANUAL LABEL
136	X1693136	ELECTRICITY LABEL
137	X1693137	PROTECTION LABEL
201	X1693201	FEED ROLL SPROCKET
202	X1693202	OIL SEAL 8 X 18 X 7
203	X1693203	BUSHING
204	XPSB31	CAP SCREW 10-24 X 5/8"
205	X1693205	BUSHING
206	X1693206	BUSHING
207	X1693207	OUTPUT SHAFT
208	X1693208	SECONDARY WORM GEAR
209	X1693209	SPACER
210	X1693210	SPRING PIN
212	X1693212	PRIMARY WORM SHAFT
213	XP609	BALL BEARING 609ZZ
214	XPSS05	SET SCREW 5/16"-18 X 1/4"
216	XP625	BALL BEARING 625ZZ
217	X1693217	GEAR BOX PLUG
218	X1693218	SECONDARY WORM SHAFT
220	X1693220	PRIMARY WORM GEAR
221	X1693221	OIL CUP
222	X1693222	OIL SEAL 9 X 20 X 7
224	XPSB39	CAP SCREW 5-40 X 1/2"
225	XPAW03M	HEX WRENCH 3MM
226	XPAW04M	HEX WRENCH 4MM
227	XPWR1214	OPEN-END WRENCH 12/14MM

# Warranty Card

Name \_\_\_\_\_

Street \_\_\_\_\_

City \_\_\_\_\_ State \_\_\_\_\_ Zip \_\_\_\_\_

Phone Number \_\_\_\_\_ E-Mail \_\_\_\_\_ FAX \_\_\_\_\_

MODEL # \_\_\_\_\_ Serial # \_\_\_\_\_

The following information is given on a voluntary basis and is strictly confidential.

- Where did you purchase your SHOP FOX® machine?  
\_\_\_\_\_
- How did you first learn about us?  
 Advertisement  Friend  
 Mail order Catalog  Local Store  
 World Wide Web Site  
 Other \_\_\_\_\_
- Which of the following magazines do you subscribe to.  
 American Woodworker  Today's Homeowner  
 Cabinetmaker  Wood  
 Family Handyman  Wooden Boat  
 Fine Homebuilding  Woodshop News  
 Fine Woodworking  Woodsmith  
 Home Handyman  Woodwork  
 Journal of Light Construction  Woodworker  
 Old House Journal  Woodworker's Journal  
 Popular Mechanics  Workbench  
 Popular Science  American How-To  
 Popular Woodworking  
 Other \_\_\_\_\_
- Which of the following woodworking/remodeling shows do you watch?  
 Backyard America  The New Yankee Workshop  
 Home Time  This Old House  
 The American Woodworker  Woodwright's Shop  
 Other \_\_\_\_\_
- What is your annual household income?  
 \$20,000-\$29,999  \$60,000-\$69,999  
 \$30,000-\$39,999  \$70,000-\$79,999  
 \$40,000-\$49,999  \$80,000-\$89,999  
 \$50,000-\$59,999  \$90,000 +
- What is your age group?  
 20-29  50-59  
 30-39  60-69  
 40-49  70 +
- How long have you been a woodworker?  
 0 - 2 Years  8 - 20 Years  
 2 - 8 Years  20+ Years
- How would you rank your woodworking skills?  
 Simple  Advanced  
 Intermediate  Master Craftsman
- How many SHOP FOX® machines do you own? \_\_\_\_\_
- What stationary woodworking tools do you own? Check all that apply.  
 Air Compressor  Panel Saw  
 Band Saw  Planer  
 Drill Press  Power Feeder  
 Drum Sander  Radial Arm Saw  
 Dust Collector  Lathe  
 Horizontal Boring Machine  Spindle Sander  
 Planer/Moulder  Table Saw  
 Lathe  Vacuum Veneer Press  
 Mortiser  Wide Belt Sander  
 Other \_\_\_\_\_
- Which benchtop tools do you own? Check all that apply.  
 1" x 42" Belt Sander  6" - 8" Grinder  
 5" - 8" Drill Press  Mini Lathe  
 8" Table Saw  10" - 12" Thickness Planer  
 8" - 10" Bandsaw  Scroll Saw  
 Disc/Belt Sander  Spindle/Belt Sander  
 Mini Planer/Moulder  
 Other \_\_\_\_\_
- Which portable/hand held power tools do you own? Check all that apply.  
 Belt Sander  Orbital Sander  
 Biscuit Joiner  Palm Sander  
 Circular Saw  Portable Planer  
 Detail Sander  Sabre Saw  
 Drill/Driver  Reciprocating Saw  
 Miter Saw  Router  
 Other \_\_\_\_\_
- What machines/supplies would you like to see?  
\_\_\_\_\_  
\_\_\_\_\_  
\_\_\_\_\_
- What new accessories would you like Woodstock International to carry?  
\_\_\_\_\_  
\_\_\_\_\_
- Do you think your purchase represents good value?  
 Yes  No
- Would you recommend SHOP FOX® products to a friend?  
 Yes  No
- Comments: \_\_\_\_\_  
\_\_\_\_\_  
\_\_\_\_\_  
\_\_\_\_\_

CUT ALONG DOTTED LINE

FOLD ALONG DOTTED LINE

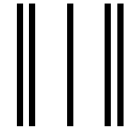

Place  
Stamp  
Here



WOODSTOCK INTERNATIONAL, INC.  
P.O. BOX 2309  
BELLINGHAM, WA 98227-2309



FOLD ALONG DOTTED LINE

TAPE ALONG EDGES--PLEASE DO NOT STAPLE







## Free Manuals Download Website

<http://myh66.com>

<http://usermanuals.us>

<http://www.somanuals.com>

<http://www.4manuals.cc>

<http://www.manual-lib.com>

<http://www.404manual.com>

<http://www.luxmanual.com>

<http://aubethermostatmanual.com>

Golf course search by state

<http://golfingnear.com>

Email search by domain

<http://emailbydomain.com>

Auto manuals search

<http://auto.somanuals.com>

TV manuals search

<http://tv.somanuals.com>