



MODEL W1747 20" PLANER



OWNER'S MANUAL

Phone: (360) 734-3482 • Online Technical Support: tech-support@shopfox.biz

COPYRIGHT © SEPTEMBER, 2006 BY WOODSTOCK INTERNATIONAL, INC.
WARNING: NO PORTION OF THIS MANUAL MAY BE REPRODUCED IN ANY SHAPE OR FORM WITHOUT
THE WRITTEN APPROVAL OF WOODSTOCK INTERNATIONAL, INC.

#8426BL

Printed in China

WARNING!

This manual provides critical safety instructions on the proper setup, operation, maintenance and service of this machine/equipment.

Failure to read, understand and follow the instructions given in this manual may result in serious personal injury, including amputation, electrocution or death.

The owner of this machine/equipment is solely responsible for its safe use. This responsibility includes but is not limited to proper installation in a safe environment, personnel training and usage authorization, proper inspection and maintenance, manual availability and comprehension, application of safety devices, blade/cutter integrity, and the usage of personal protective equipment.

The manufacturer will not be held liable for injury or property damage from negligence, improper training, machine modifications or misuse.

WARNING!

Some dust created by power sanding, sawing, grinding, drilling, and other construction activities contains chemicals known to the State of California to cause cancer, birth defects or other reproductive harm. Some examples of these chemicals are:

- Lead from lead-based paints.
- Crystalline silica from bricks, cement and other masonry products.
- Arsenic and chromium from chemically-treated lumber.

Your risk from these exposures varies, depending on how often you do this type of work. To reduce your exposure to these chemicals: Work in a well ventilated area, and work with approved safety equipment, such as those dust masks that are specially designed to filter out microscopic particles.

Contents

- INTRODUCTION** 3
 - Woodstock Technical Support..... 3
 - Specifications 4
 - Controls and Features 5
- SAFETY**..... 6
 - Standard Safety Instructions 6
 - Additional Safety Instructions for Planers 8
- ELECTRICAL** 9
 - 220V Operation..... 9
 - Extension Cords 9
 - Grounding 9
- SET UP** 10
 - Unpacking 10
 - Items Needed for Set Up..... 10
 - Inventory 10
 - Machine Placement 11
 - Lifting Planer 11
 - Cleaning Machine 12
 - Extension Wings 13
 - Handwheel 14
 - Dust Hood 14
 - Gearbox Oil Level..... 15
 - Connecting to Power 15
 - Knife Setting Gauge 15
 - Test Run 16
 - Tighten V-Belts 16
 - Recommended Adjustments..... 16
- OPERATIONS** 17
 - General 17
 - Basic Operation..... 17
 - Operation Tips..... 18
 - Feed Speed..... 19
 - Bed Rollers 20
- ACCESSORIES** 21
 - Planer Accessories 21
- MAINTENANCE** 23
 - General 23
 - Cleaning 23
 - Maintenance Schedule..... 23
 - V-Belts 24
 - Lubrication 25

USE THE QUICK GUIDE PAGE LABELS TO SEARCH OUT INFORMATION FAST!

SERVICE	26
General	26
Inspecting Knives.....	26
Setting/Replacing Knives	27
Chain Tension.....	28
Table Parallelism.....	29
Rollers, Chip Breaker & Pressure Bar Heights.....	31
Spring Tension	34
Chip Deflector Positioning	35
Scale Calibration	35
Anti-Kickback Fingers	36
Pulley Alignment	37
W1747 Electrical Components	38
W1747 Wiring Diagram	39
Troubleshooting	40
Headstock Assembly Parts Breakdown.....	42
Headstock Assembly Parts List.....	43
Table, Base, and Columns Parts Breakdown	45
Table, Base, and Columns Parts List.....	46
Stand/Motor Assembly Parts Breakdown	47
Stand/Motor Assembly Parts List	48
Warning Label Placement and Parts List.....	49

INTRODUCTION

SAFETY

ELECTRICAL

SET UP

OPERATIONS

MAINTENANCE

SERVICE

PARTS



USE THE QUICK GUIDE PAGE LABELS TO SEARCH OUT INFORMATION FAST!

INTRODUCTION

Woodstock Technical Support

Your new **SHOP FOX**® planer has been specially designed to provide many years of trouble-free service. Close attention to detail, ruggedly built parts and a rigid quality control program assure safe and reliable operation.

Woodstock International, Inc. is committed to customer satisfaction. Our intent with this manual is to include the basic information for safety, setup, operation, maintenance, and service of this product.

We stand behind our machines! In the event that questions arise about your machine, please contact Woodstock International Technical Support at (360) 734-3482 or send e-mail to: tech-support@shopfox.biz. Our knowledgeable staff will help you troubleshoot problems and process warranty claims.

If you need the latest edition of this manual, you can download it from <http://www.shopfox.biz>.
If you have comments about this manual, please contact us at:

Woodstock International, Inc.
Attn: Technical Documentation Manager
P.O. Box 2309
Bellingham, WA 98227

Specifications

Motor:

Type TEFC Capacitor-Start Induction
 Horsepower 5 HP
 Phase / Voltage Single-Phase / 220V
 Amps 30
 Cycle / RPM 60 Hertz / 3450 RPM
 Switch Magnetic with Thermal Overload Relay
 Power Transfer Triple V-Belt Drive
 Bearings Shielded & Lubricated Ball Bearings

Capacity:

Maximum Depth of Cut 1/8"
 Maximum Width of Cut 20"

 Maximum Cutting Height 8"
 Minimum Stock Thickness 1/4"
 Minimum Stock Length 7"
 Cutterhead Diameter 3⁵/₃₂"
 Cutterhead Speed 5,500 RPM
 Cuts per Minute 22,000
 Feed Rates 18 FPM & 23 FPM
 Cuts Per Inch (Effective) 25 & 20

Overall Dimensions:

Table Size 25³/₄" x 20"
 Height 43"
 Overall Depth 56"
 Overall Width 41¹/₂"
 Shipping Weight 910 lbs.
 Net Weight 810 lbs.
 Base Dimensions 27¹/₂" L x 23" W x 13³/₄" H
 Crate Size 29¹/₂" L x 43³/₈" W x 46¹/₄" H
 Footprint 25" x 28¹/₂"

Construction:

Table Precision-Ground Cast Iron
 Infeed Roller Spiral Serrated / Steel
 Outfeed Roller Steel
 Stand Formed Steel
 Cutterhead 4 Knife
 Knife Size 20¹/₁₆" L x 1" W x 1/8" H
 Knife Adjustment Springs and Jack Screws

Features:

..... Cast Iron Extension Tables
 Two Table Locks
 5" Dust Port
 Inch & Metric Measurement Scale
 2 Adjustable Bed Rollers
 Board Return Rollers

Controls and Features

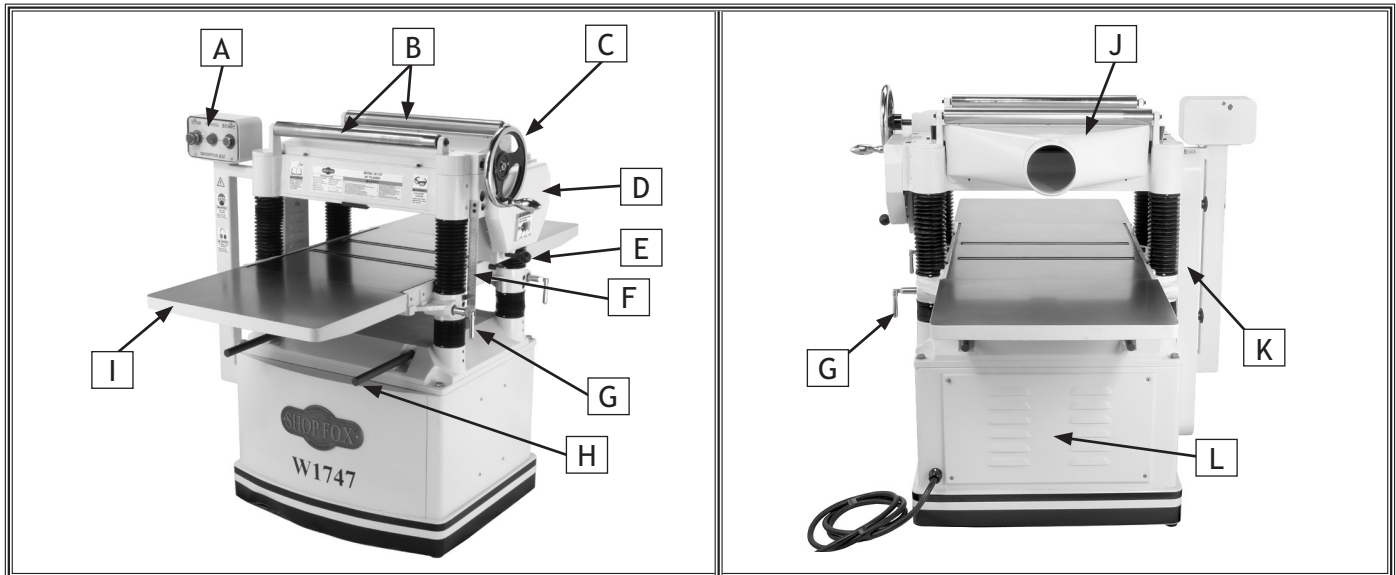

Figure 1. W1747 Controls and features.

- A. Control Box and Panel
- B. Return Rollers
- C. Table Height Handwheel
- D. Gearbox
- E. Speed Control Knob
- F. Table Height Scale
- G. Table Locks
- H. Lifting Bar
- I. Extension Wing
- J. Dust Hood
- K. V-Belt Cover
- L. Motor and Magnetic Switch Access Panel

SAFETY

**READ MANUAL BEFORE OPERATING MACHINE.
FAILURE TO FOLLOW INSTRUCTIONS BELOW WILL
RESULT IN PERSONAL INJURY.**



Indicates an imminently hazardous situation which, if not avoided, **WILL** result in death or serious injury.



Indicates a potentially hazardous situation which, if not avoided, **COULD** result in death or serious injury.



Indicates a potentially hazardous situation which, if not avoided, **MAY** result in minor or moderate injury.

NOTICE

This symbol is used to alert the user to useful information about proper operation of the equipment, and/or a situation that may cause damage to the machinery.

Standard Safety Instructions

1. **READ THROUGH THE ENTIRE MANUAL BEFORE STARTING MACHINERY.** Machinery presents serious injury hazards to untrained users.
2. **ALWAYS USE ANSI APPROVED SAFETY GLASSES WHEN OPERATING MACHINERY.** Everyday eye-glasses only have impact resistant lenses—they are NOT safety glasses.
3. **ALWAYS WEAR AN NIOSH APPROVED RESPIRATOR WHEN OPERATING MACHINERY THAT PRODUCES DUST.** Wood dust is a carcinogen and can cause cancer and severe respiratory illnesses.
4. **ALWAYS USE HEARING PROTECTION WHEN OPERATING MACHINERY.** Machinery noise can cause permanent hearing damage.
5. **WEAR PROPER APPAREL.** DO NOT wear loose clothing, gloves, neckties, rings, or jewelry which may get caught in moving parts. Wear protective hair covering to contain long hair and wear non-slip footwear.
6. **NEVER OPERATE MACHINERY WHEN TIRED, OR UNDER THE INFLUENCE OF DRUGS OR ALCOHOL.** Be mentally alert at all times when running machinery.
7. **ONLY ALLOW TRAINED AND PROPERLY SUPERVISED PERSONNEL TO OPERATE MACHINERY.** Make sure operation instructions are safe and clearly understood.
8. **KEEP CHILDREN AND VISITORS AWAY.** Keep all children and visitors a safe distance from the work area.
9. **MAKE WORKSHOP CHILD PROOF.** Use padlocks, master switches, and remove start switch keys.

10. **NEVER LEAVE WHEN MACHINE IS RUNNING.** Turn power **OFF** and allow all moving parts to come to a complete stop before leaving machine unattended.
11. **DO NOT USE IN DANGEROUS ENVIRONMENTS.** DO NOT use machinery in damp, wet locations, or where any flammable or noxious fumes may exist.
12. **KEEP WORK AREA CLEAN AND WELL LIT.** Clutter and dark shadows may cause accidents.
13. **USE A GROUNDED EXTENSION CORD RATED FOR THE MACHINE AMPERAGE.** Undersized cords over-heat and lose power. Replace extension cords if they become damaged. DO NOT use extension cords over 50 feet without consulting a qualified electrician.
14. **ALWAYS DISCONNECT FROM POWER SOURCE BEFORE SERVICING MACHINERY.** Make sure switch is in OFF position before reconnecting.
15. **MAINTAIN MACHINERY WITH CARE.** Keep blades sharp and clean for best and safest performance. Follow instructions for lubricating and changing accessories.
16. **MAKE SURE GUARDS ARE IN PLACE AND WORK CORRECTLY BEFORE USING MACHINERY.**
17. **REMOVE ADJUSTING KEYS AND WRENCHES.** Make a habit of checking for keys and adjusting wrenches before turning machinery **ON**.
18. **CHECK FOR DAMAGED PARTS BEFORE USING MACHINERY.** Check for binding and alignment of parts, broken parts, part mounting, loose bolts, and any other conditions that may affect machine operation. Repair or replace damaged parts.
19. **USE RECOMMENDED ACCESSORIES.** Refer to the instruction manual for recommended accessories. The use of improper accessories may cause risk of injury.
20. **DO NOT FORCE MACHINERY.** Work at the speed for which the machine or accessory was designed.
21. **SECURE WORKPIECE.** Use clamps or a vise to hold the workpiece when practical. A secured workpiece protects your hands and frees both hands to operate the machine.
22. **DO NOT OVERREACH.** Keep proper footing and balance at all times.
23. **MANY MACHINES WILL EJECT THE WORKPIECE TOWARD THE OPERATOR.** Know and avoid conditions that cause the workpiece to "kickback."
24. **ALWAYS LOCK MOBILE BASES (IF USED) BEFORE OPERATING MACHINERY.**
25. **BE AWARE THAT CERTAIN DUST MAY BE HAZARDOUS** to the respiratory systems of people and animals, especially fine dust. Make sure you know the hazards associated with the type of dust you will be exposed to and always wear a respirator approved for that type of dust.

Additional Safety Instructions for Planers

SAFETY



⚠️ WARNING
 READ and understand this entire instruction manual before using this machine. Serious personal injury may occur if safety and operational information is not understood and followed. **DO NOT** risk your safety by not reading!

⚠️ CAUTION
 USE this and other machinery with caution and respect. Always consider safety first, as it applies to your individual working conditions. No list of safety guidelines can be complete—every shop environment is different. Failure to follow guidelines could result in serious personal injury, damage to equipment or poor work results.

1. **INFEEED CLEARANCE SAFETY:** The infeed roller is designed to pull material into the cutterhead. Always keep hands, clothing, and long hair away from the infeed roller during operation to prevent serious injury.
2. **BODY POSITION WHILE OPERATING:** The workpiece may kick out during operation. To avoid getting hit, stand to the side of the planer during the entire operation.
3. **PLANING CORRECT MATERIAL:** Planing materials not designed for this planer creates a hazard for yourself and the machine. Only plane natural wood stock with this planer. **DO NOT** plane MDF, plywood, laminates, or other synthetic or man-made products.
4. **GRAIN DIRECTION:** Planing across the grain is hard on the planer and may cause the workpiece to kick out. Always plane in the same direction or at a slight angle with the wood grain.
5. **CLEAN STOCK:** Planing stock with nails, staples, or loose knots *MAY* cause debris to kick out at the operator and **WILL** damage your cutters when they contact the cutterhead. Always thoroughly inspect and prepare stock to avoid these hazards.
6. **MACHINE LIMITATIONS:** The planer may kick out a workpiece at you or you can damage it if it is pushed beyond these limits:
 - Maximum Depth of Cut: 1/8"
 - Minimum Board Length: 7"
 - Minimum Board Thickness: 1/4"
 - Maximum # of Boards at One Time: 1
7. **LOOKING INSIDE PLANER:** Wood chips fly around inside the planer at a high rate of speed. **DO NOT** look inside the planer or remove guards/covers during operation.
8. **REMOVING JAMMED WORKPIECES:** Attempting to remove jammed workpieces while the planer is running may cause serious injury to the operator. Always stop the planer and disconnect power before removing jams.
9. **DULL/DAMAGED CUTTERS:** The planer may kick out a workpiece at the operator or give poor finish results if it is operated with dull or damaged cutters.
10. **UNPLUGGING DURING ADJUSTMENTS:** When connected to power, the planer can be accidentally turned **ON**. Always disconnect power when servicing or adjusting the components of the planer.

ELECTRICAL

220V Operation

The Model W1747 operates at 220V. Always connect this machine to a dedicated circuit with a verified ground, using the recommended circuit size listed at the bottom of this page.

Never replace a circuit breaker with one of higher amperage without consulting a qualified electrician to ensure compliance with wiring codes. If you are unsure about the wiring codes in your area or plan to connect your machine to a shared circuit, you may create a fire hazard—consult a qualified electrician to reduce this risk.

Extension Cords

We do not recommend using an extension cord for 220V operation. Instead, hard wire the machine directly to a power panel that is equipped with a manual shutoff lever lever and that can be locked in the OFF position.

Grounding

This machine must be grounded! Hardwire this machine into a power supply circuit that contains a ground circuit. If you have any questions about correct electrical installation, contact a qualified electrician for assistance to make sure all connections are safe and adhere to required electrical codes.

⚠ WARNING

Electrocution or severe shock could occur if machine is not grounded.

⚠ CAUTION

Replacing an existing circuit breaker with one rated for higher amperage may result in a fire. Get help from an electrician if your circuit will be overloaded by the machine.

⚠ WARNING

TURN OFF and LOCK your master power switch so no power is available to the planer before connecting electrical wires! If you ignore this warning serious electrical shock may occur, causing injury or death!

Operating Voltage	Amp Draw	Min. Circuit Size	Plug/Receptacle	Extension Cord
220V Operation	30 Amps	40A	Hardwire	Not Recommended

ELECTRICAL

SET UP

Unpacking

The SHOP FOX® Model W1747 has been carefully packaged for safe transporting. If you notice the machine has been damaged, please contact your authorized SHOP FOX® dealer immediately.

Items Needed for Set Up

The following items are needed, but not included, to setup your machine:

- Safety Glasses (for each person).....1
- Solvent Cleaner1
- Shop Rags for Cleaning As Needed
- Extra Person for Lifting Help1
- Fork Lift.....1
- Straightedge (see Page 13).....1
- Phillips Screwdriver #21

Inventory

The following is a description of the main components shipped with the SHOP FOX® Model W1747. Lay the components out to inventory them.

Note: Some parts and hardware may already be installed on the machine. Make sure to check the machine when you use this inventory list.

Box Inventory (Figure 2)	Qty
A. Planer Unit	1
B. Knife Gauge Assembly	1
C. Dust Hood.....	2
D. Handwheel.....	1
E. Table Extension Wings.....	1

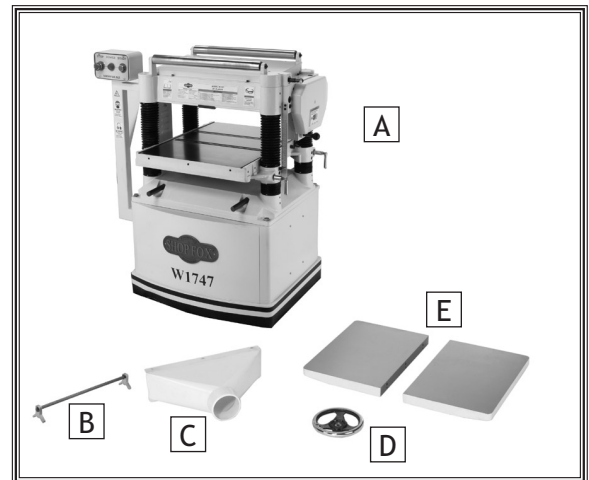
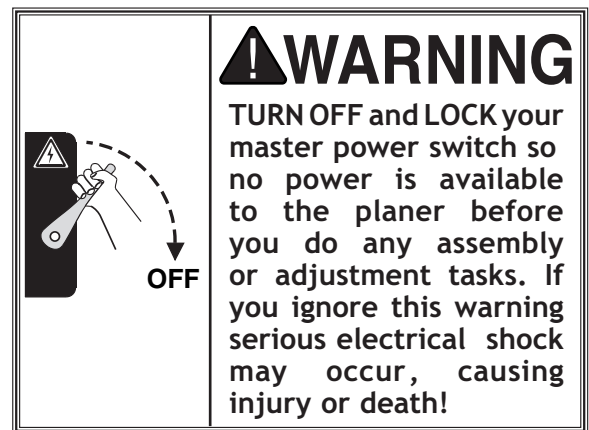
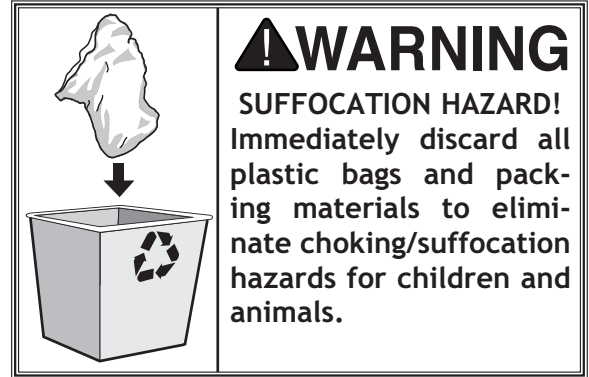

Figure 2. Planer box inventory.

SET UP

Hardware and Tools

- Hex Wrenches 3, 4, 5, 6mm.....4
- Wrenches 8/10, 12/14, 17/19mm3
- Set Screws M8-1.25 x 20 (Wings).....6
- Hex Bolts M8-1.25 x 25 (Wings)6
- Handwheel Bushing (Handwheel)1
- Handwheel Handle (Handwheel).....1
- Hex Nut M12-1.75 (Handwheel) 1
- Flat Washer 12mm (Handwheel).....1
- Key 4 x 4 x 10mm (Handwheel)1
- Cap Screws M6-1 x 12 (Dust Hood)6
- Flat Washers 6mm (Dust Hood)6

If any parts are missing, examine the packaging for the missing parts. For any missing parts, find the part number in the back of this manual and contact Woodstock International, Inc. at (360) 734-3482 or at tech-support@shopfox.biz

Machine Placement

- **Floor Load:** This machine distributes a heavy load in a small footprint. Some floors may require additional bracing to support both machine and operator.
- **Working Clearances:** Consider existing and anticipated needs, size of material to be processed through the machine, and space for auxiliary stands, work tables or other machinery when establishing a location for your planer.
- **Lighting:** Lighting should be bright enough to eliminate shadow and prevent eye strain.

Lifting Planer

The cabinet stand on the Model W1747 is equipped with lifting bars (see Page 5) to lift and place the planer.

When lifting the planer with a forklift, we recommend placing shop rags or cardboard between the forks and cabinet base so you do not scratch the paint.

Figure 3 shows an example of a typical planer with lifting bars being lifted correctly with a forklift.

⚠ CAUTION



MAKE your shop "child safe." Ensure that your workplace is inaccessible to youngsters by closing and locking all entrances when you are away. **NEVER** allow untrained visitors in your shop when assembling, adjusting or operating equipment.



Figure 3. Example of planer being lifted using forklift.

SET UP



⚠ WARNING

USE power lifting equipment to lift this planer. Otherwise, serious personal injury may occur.

Cleaning Machine

The table and other unpainted parts of your planer are coated with a waxy grease that protects them from corrosion during shipment. Clean this grease off with a solvent cleaner or citrus-based degreaser. **DO NOT** use chlorine-based solvents such as brake parts cleaner or acetone—if you happen to splash some onto a painted surface, you will ruin the finish.

These items are coated and must be cleaned:

1. Cutterhead
2. Table
3. Feed Rollers
4. Extension Wings and Wing Mounting Surfaces

⚠ WARNING

NEVER use gasoline or other petroleum-based solvents to clean with. Most have low flash points, which make them extremely flammable. A risk of explosion and burning exists if these products are used. Serious personal injury may occur if this warning is ignored!

⚠ CAUTION

ALWAYS work in well-ventilated areas far from possible ignition sources when using solvents to clean machinery. Many solvents are toxic when inhaled or ingested. Use care when disposing of waste rags and towels to be sure they **DO NOT** create fire or environmental hazards.

SET UP

Extension Wings

⚠ CAUTION

Extension wings are heavy and could cause personal injury if dropped during installation. Have an assistant hold the table while you fasten it to the planer.

To attach the table extension wings, do these steps:

1. With the help of an assistant, attach the table extension wings to the planer table (**Figure 4**) with the M8-1.25 x 25 hex bolts. Finger tighten the bolts for now.
2. Install the M8-1.25 x 20 set screws (**Figure 4**) in the holes in the bottom of the wings.
3. Check table-to-extension wing alignment (**Figure 5**) with a straightedge and adjust the leveling set screws until the table and wings are flush.
4. Tighten the hex bolts.

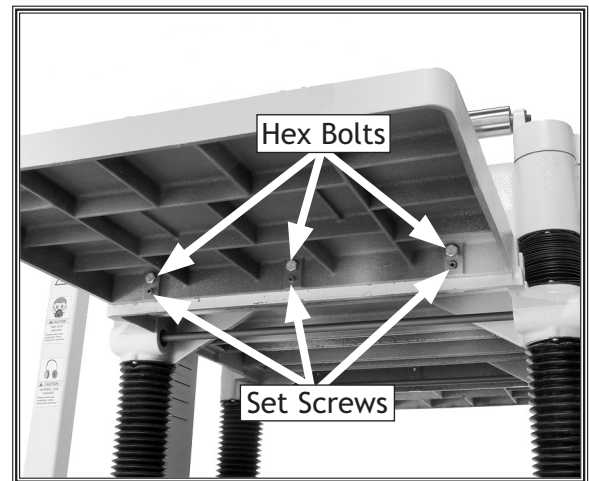

Figure 4. Extension wing fasteners and leveling controls.

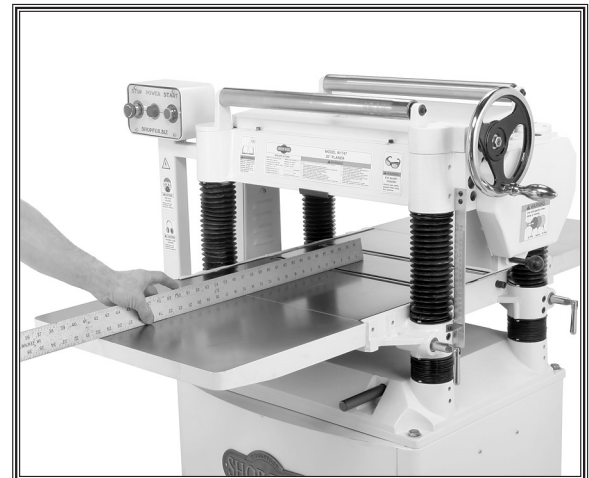

Figure 5. Leveling extension wings and table.

Handwheel

To install the handwheel, do these steps:

1. Place the bushing on the handwheel shaft.
2. Insert the key into the shaft keyway.
3. Thread the handle into the handwheel.
4. Place the handwheel on the shaft and secure it with the M12-1.75 hex nut and flat washer, as shown in Figure 6.



Figure 6. Installing handwheel on shaft.

Dust Hood

CAUTION

During the next step, **DO NOT** attach the dust hood if you do not intend to connect your planer to a dust collection system. Accumulated wood chips could cause a malfunction, resulting in personal injury or damage to the planer.

To install the dust hood, do these steps:

1. Attach the dust hood to the planer with six M6-1 x 12 cap screws and flat washers as shown in Figure 7.
2. Attach the dust hood to the dust collector.

Note: To maximize work results and minimize clogging, chipout, etc., use a dust collector with your planer!

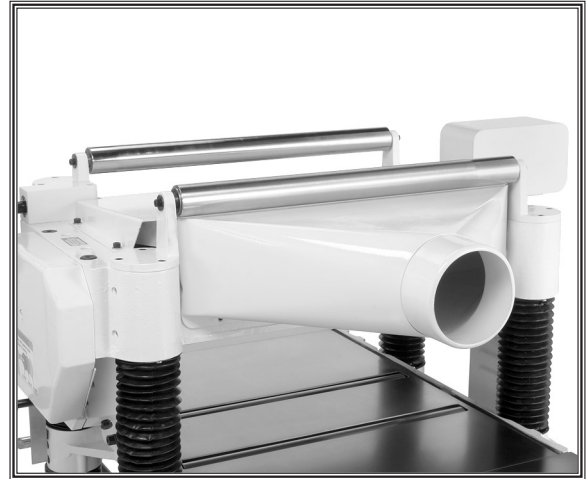

Figure 7. Dust hood attached.

Gearbox Oil Level

Before starting your machine for the first time, make sure the gearbox has oil. The proper oil level is just even with the bottom of the fill plug hole. The gearbox uses 80W-90W automotive grade gear oil.

To check the gearbox oil level, do these steps:

1. Wipe the outside of the fill plug clean.
2. Using a 14mm wrench or socket, remove the gearbox fill plug (**Figure 8**).
3. Using the short end of a CLEAN 6mm hex wrench, dip it inside the fill hole and remove it. (Do not drop the wrench into the gearbox!)
 - If the end of the hex wrench is coated with oil, then the gearbox oil level is okay. Replace the fill plug and continue with set up.
 - If the end of the hex wrench is not coated with oil, then fill the gearbox with 80-90W gear oil until the oil reaches the top of the fill plug.

Note: Replace the gearbox oil after the first 20 hours of operation. This is a normal break-in procedure.



Figure 8. Gearbox fill plug location.

Connecting to Power

Now is the time to connect your planer to the power source. Make sure you have read and followed precautions listed on **Page 9**, before doing so.

Knife Setting Gauge

Assemble the knife setting gauge as shown in **Figure 9**.

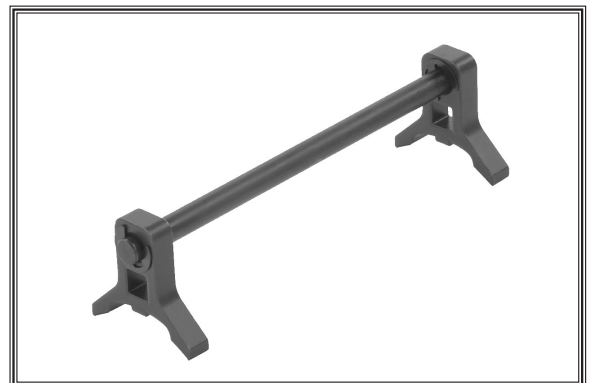

Figure 9. Knife setting gauge assembled.

Test Run

Complete this process once you have familiarized yourself with all instructions in this manual. The purpose of the test run is to make sure the motor is working properly before proceeding.

To perform a test run, do these steps:

1. Read the entire manual, and make sure oil is in the gearbox.
2. Make sure all tools and foreign objects have been removed from the machine.
3. Put on safety glasses, and secure loose clothes or long hair.
4. Press the green button to turn the machine **ON**. The planer should run smoothly with little or no vibration.
 - If you suspect any problems, immediately turn the planer **OFF** by pushing the red STOP button. Refer to **Page 40** to troubleshoot/fix any problems before starting the planer again.
 - If the source of an unusual noise or vibration is not readily apparent, contact our technical support for help at (360) 734-3482 or contact us online at tech-support@shopfox.biz.

Tighten V-Belts

The final step in the set up process must be done after approximately 16 hours of operation. During this first 16 hours, the V-belts will stretch and seat into the pulley grooves. After this 16 hours, the V-belts must be tensioned or your belts will slip and burn out. Refer to **Page 24** when you are ready to perform this important adjustment.

Note: *Pulleys and belts run very hot. This is a normal condition. Allow them to cool before making adjustments.*

Note: *A collection of black belt dust at the bottom of the belt housing is a normal during the life of the machine and does not indicate premature belt failure is in progress.*

! WARNING



Loose hair and clothing could get caught in machinery and cause serious personal injury. Keep loose clothing rolled up and long hair tied up and away from machinery.

Recommended Adjustments

For your convenience, the adjustments listed below have been performed at the factory and no further setup is required to operate your machine.

However, because of the many variables involved with shipping, some of these adjustments may need to be repeated to ensure optimum cutting results. Keep this in mind as you start to use your new planer.

Step-by-step instructions for these adjustments can be found in the **SERVICE** section.

1. Table Parallelism (**Page 29**).
2. Chain Tension (**Page 28**).
3. Spring Tension (**Page 34**).
4. Rollers, Chip Breakers and Pressure Bar Heights (**Page 31**).
5. Chip Deflector Positioning (**Page 35**).

OPERATIONS

General

The Model W1747 will perform many types of operations that are beyond the scope of this manual. Many of these operations can be dangerous or deadly if performed incorrectly.

The instructions in this section are written with the understanding that the operator has the necessary knowledge and skills to operate this machine. **If at any time you are experiencing difficulties performing any operation, stop using the machine!**

If you are an inexperienced operator, we strongly recommend that you read books, trade articles, or seek training from an experienced planer operator before performing any unfamiliar operations. **Above all, your safety should come first!**

Basic Operation

The W1747 table moves approximately $1/16$ " with one turn of the handwheel.

The basic steps of operating the planer are as follows:

1. Put on safety glasses, respirator, and ear muffs.
2. Unless your workpiece is very flat, surface plane the workpiece on a jointer until it is flat—having the face flat will ensure that it sits flat on the planer table during operation.
3. Adjust the table height slightly lower than your workpiece to ensure the first cut is as light as possible (approximately $1/32$ "- $1/16$ "). This cut removes any excessive high spots.
4. Start the planer.
5. Making sure not to stand directly in front or behind the workpiece to avoid kickback injury, place the flat side of the board down on the table, and feed the workpiece through the planer.
 - If the cut is too heavy and bogs down the planer, turn the planer **OFF** immediately, allow it to come to a complete stop, remove the workpiece, and repeat **Steps 3-5**.

WARNING



READ and understand this entire instruction manual before using this machine. Serious personal injury may occur if safety and operational information is not understood and followed. **DO NOT** risk your safety by not reading!

WARNING

Damage to your eyes, lungs, and ears could result from using this machine without proper protective gear. Always wear safety glasses, a respirator, and hearing protection when operating this machine.

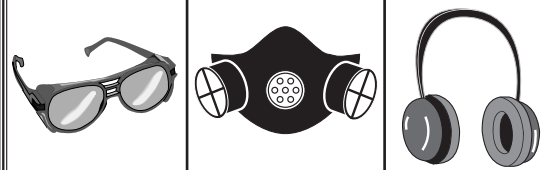

WARNING

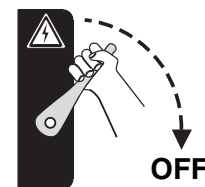

DO NOT investigate problems or adjust the planer while it is running. Wait until the machine is turned **OFF** and all working parts have come to a complete stop before proceeding!

6. Measure your workpiece thickness and adjust the table height as necessary to take a lighter or heavier pass, depending on your needs. For most wood types, $1/16$ " per pass is a good cutting depth.

Note: *Any time you switch directions with the handwheel, there will be a small amount of backlash—so the first crank of the handwheel after switching directions will be slightly less than $1/16$ ". However, as long as you move the handwheel in the same direction during operation, backlash will not be a factor.*

Operation Tips

- Inspect lumber for defects, warping, cupping, twisting, and for foreign objects (nails, staples, imbedded gravel, etc.). If you have any question about the quality of your lumber, do not use it. Remember, wood stacked on a concrete floor can have small pieces of stone or concrete pressed into the surface.
- Use the full width of the planer. Alternate between the left, the right, and the middle when feeding lumber into the planer. Your cutters will remain sharp much longer.
- Scrape all glue off of joined boards before planing.
- Plane ONLY natural wood fiber. No wood composites (OSB, MDF, particle board, etc.).
- Plane wood with the grain. Never feed end-cut or end-grained lumber into your planer.
- Do not use boards with loose or large knots, splits, crossgrain or other obvious blemishes or defects. They can damage the machine and pose the possibility of operator injury.
- Keep your work area clear.
- When making multiple passes through the planer on long stock, use the stock return rollers on the top of the machine to move the material back to the infeed side of the machine.
- Avoid planing wood with a high water content. Wood with more than 20% moisture content or wood exposed to rain or snow, will plane poorly and cause excessive wear to the cutters and motor. Excess moisture can also hasten rust and corrosion.

Feed Speed

The infeed and outfeed rollers power the stock through the planer while keeping boards flat and providing a consistent rate of movement.

The power feed features high/low feed rates. Use the different feed rates as stated below:

Low Feed Rate Dimensioning Pass
High Feed Rate Finishing Pass

Figure 10 illustrates the three different positions of the feed control knob. Moving the knob toward the machine (**Position A**) produces the high feed speed (23 FPM) moving away from the machine (**Position C**) produces the low speed (18 FPM) and moving the knob to the center position (**Position B**) places the gearbox in neutral.

The speed should only be changed when the machine is running.

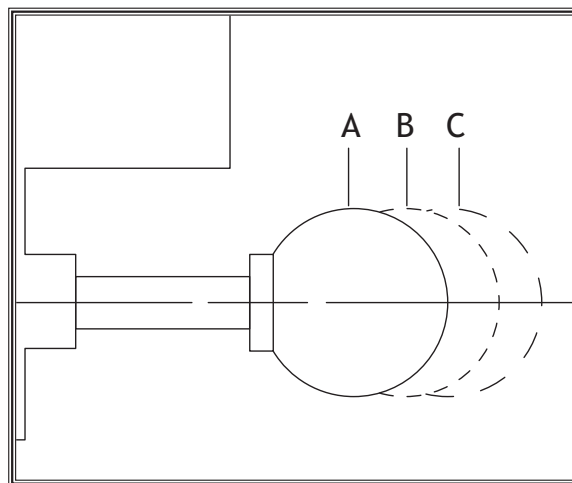

Figure 10. Feed control knob positions.

NOTICE

Only change the speeds when the planer is running, but **DO NOT** attempt to change speeds during any cutting operations or damage to the gearbox will result.

Bed Rollers

Adjustment Height Range: 0.002"-0.020"

The height of the bed rollers will vary, depending on the type of material you intend to plane, but as a general rule keep the roller height within 0.002"-0.020" above the table (Figure 27). When planing rough stock, set the rollers high to keep the lumber from dragging along the bed. When planing milled lumber, set the rollers low to help minimize snipe.

To ensure accurate results and make the adjustment process quicker and easier, we recommend using a W1218 Rotacator (see Page 21) to gauge the bed roller height from the table. If a Rotacator is not available, a straight-edge and feeler gauges can be used, but extra care must be taken to achieve satisfactory results.

Note: *Misaligned bed rollers can cause workpiece chatter, a washboard surface, uneven workpiece feeding, or binding.*

To adjust the bed rollers, do these steps:

1. DISCONNECT THE PLANER FROM THE POWER SOURCE!
2. Lower the table to give yourself at least 4" of working room below the cutterhead.
3. Using a 3mm hex wrench, loosen the locking set screws (Figure 12) above the roller adjusters (4 total).
4. Raise or lower the rollers by rotating the roller adjusters to reach your desired height.
5. Verify both sides of the bed roller are at the same height in relation with each other and to the table surface, and lock them in position with the locking set screws.
6. Double check the roller heights to make sure they did not move when you locked them (if they did, repeat the procedure).

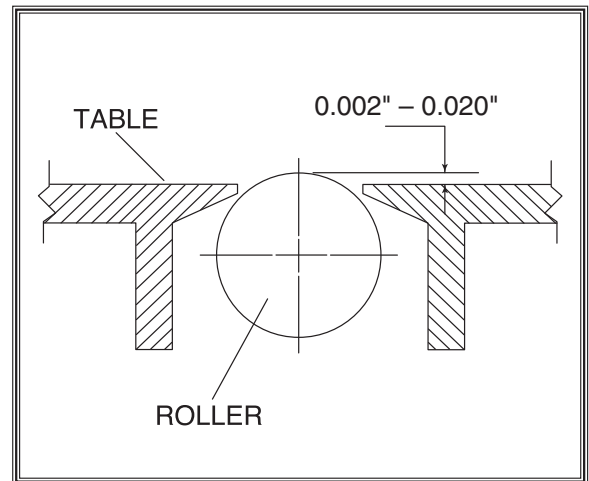

Figure 11. Bed roller height range.

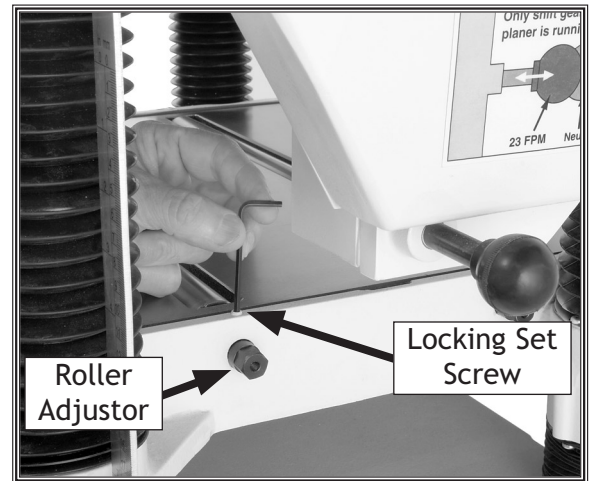

Figure 12. Bed roller controls (only one side shown).

ACCESSORIES

Planer Accessories

The following planer accessories may be available through your local Woodstock International Inc. Dealer. If you do not have a dealer in your area, these products are also available through online dealers. Please call or e-mail Woodstock International Inc. Customer Service to get a current listing of dealers at: 1-800-545-8420 or at sales@woodstockint.com.

The **SHOP FOX® Heavy-Duty Roller Stands and Roller Tables** make your planer safer and easier to use. All models feature convenient hand knobs for fast height adjustment and offer rigid steel construction. These stands are invaluable for supporting long workpieces on your planer.

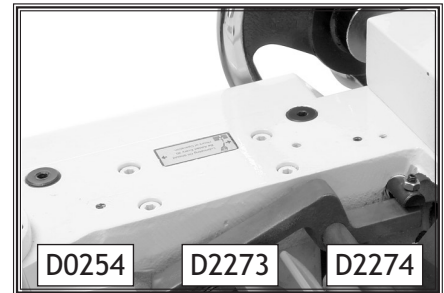

The **D2271 SHOP FOX® Heavy-Duty Roller Table** is a versatile roller table wherever you need extra workpiece support for up to a 1,000 lb. capacity. It features all-steel welded construction and it measures 19" x 65" long. The roller table also comes with 9 ball bearing rollers with four independently adjustable legs for any leveling requirement. The roller table is also adjustable in height from 26³/₈" to 44¹/₈".



The **W1218 Rotacator®** makes a planer setup process easier and more accurate for adjusting the table rollers, feed rollers, chip breaker, and the pressure bar if equipped on your planer. This tool is a rotating dial indicator on a magnetic base. Shown to the right, this handy device measures table-to-cutterhead alignment and the table roller height. The Rotacator® allows you to set your table within 0.001" from being parallel with the cutterhead.

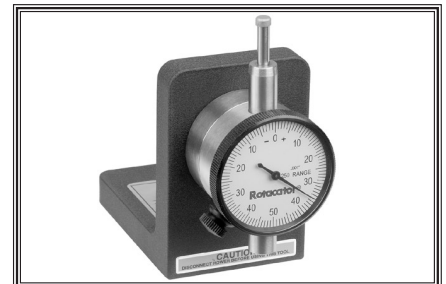

PLANER PAL® Magnetic Planer Knife Setting Jigs. Our patented knife-setting system lets you set straight-type planer knives in perfect alignment every time! You can shift nicked knives on 2 1/2"- 4" cutterheads to get a perfect cut with an accuracy of ±.002". Two jigs are needed for 15"- 20" planers. Use the STANDARD JIGS for Steel Knives W1216 (Pair), or the CARBIDE JIGS for Steel or Carbide Knives W1217 (Pair).



The **SHOP FOX® Wood Rack System** features interchangeable rack bars and shelf brackets to create simple or elaborate wood racks. 24" and 48" rack bars can be joined together to provide 6 feet of vertical storage capacity. Easily adjustable 12" and 18" shelf brackets lock into the rack bars for a secure system. Weight capacity is 300 lbs. for 12" brackets and 200 lbs. for 18" brackets when wood rack bars are supported by the floor and weight is evenly distributed. Assembly instructions included. D2829 24" Wood Rack Bars, D2830 48" Wood Rack Bars, D2831 12" Wood Rack Shelf Brackets, and D2832 18" Wood Rack Shelf Brackets.



MAINTENANCE

General

Regular periodic maintenance on your **SHOP FOX®** Model W1747 will ensure its optimum performance. Make a habit of inspecting your machine each time you use it.

Check for the following conditions and repair or replace when necessary:

- Loose mounting bolts.
- Worn switch.
- Worn or damaged cords and plugs.
- Damaged V-belt.
- Any other condition that could hamper the safe operation of this machine.

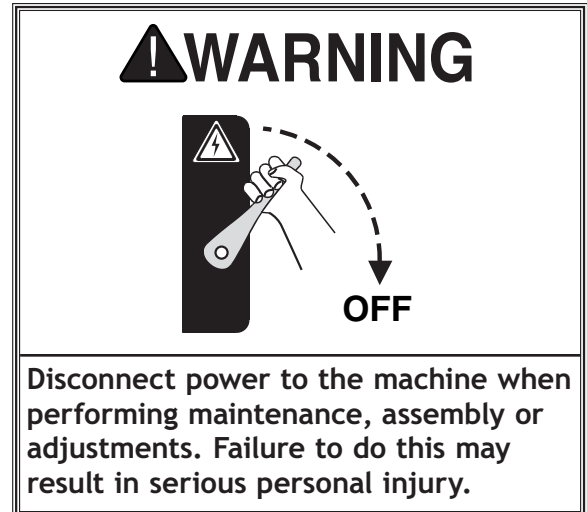

Cleaning

Vacuum excess wood chips and sawdust, and wipe off the remaining dust with a dry cloth. Protect the unpainted cast iron surfaces on the table by wiping the table clean after every use. Keep tables rust-free with regular applications of quality metal protectants.

Maintenance Schedule

For optimum performance from your machine, follow this maintenance schedule and refer to any specific instructions given in this section.

Daily Maintenance:

- Clean the unpainted cast iron part of the table
- Lubricate feed rollers

Weekly Maintenance:

- Clean cutterhead
- Lubricate four columns

Monthly Maintenance:

- Inspect V-belt tension, damage, or wear
- Clean/vacuum dust buildup from inside cabinet and off motor
- Lubricate worm gear
- Lubricate drive chain

Yearly Maintenance:

- Change gear box oil (See Page 25)

V-Belts

V-belt removal and replacement is simply a matter of loosening the V-belts, rolling them off of the pulleys, replacing them with new belts, then retensioning them.

Always replace V-belts with a matched set of 3 belts, or belt tension may not be even among the 3 belts and may cause premature belt failure.

To adjust/replace the V-belts, do these steps:

1. DISCONNECT THE PLANER FROM THE POWER SOURCE!
2. Open the motor access panel and V-belt cover.
3. Using a 19mm wrench, loosen the fasteners on the tension rods shown in **Figure 13**.
4. Lift the motor up and slide the V-belts off of the pulleys.
5. Slide the new belts onto the pulley, lower the motor, and tighten the fasteners loosened in **Step 3**.
6. Close the V-belt cover and motor access panel.

Note: The correct tension for the V-belts is $\frac{1}{4}$ " deflection when pushed in the center with moderate pressure. After the first 16 hours of belt life, retension them, as they will stretch and seat during this time.

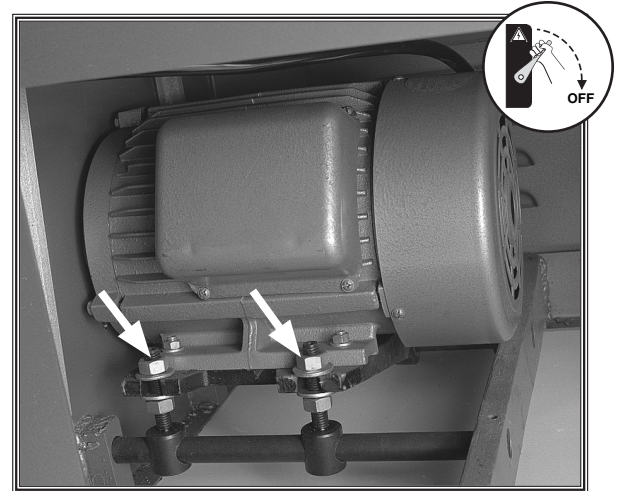

Figure 13. Fasteners needed to be loosened for V-belt replacement.

Lubrication

This planer uses sealed and pre-lubricated ball bearings that require no lubrication.

The following is a list of parts that need lubrication:

Columns/Lead Screws: The four columns should be lubricated weekly with SAE 30W oil. Unfasten dust covers to gain access. The four lead screws (**Figure 14**) should be lubricated with general purpose grease once a month.

Worm Gear: The worm gear should be inspected monthly and lubricated with general purpose grease when needed. Remove the worm gear box to inspect. See parts diagram on **Page 44** for location.

Chain: The table height adjustment chain (see **Figure 21** on **Page 28**) should be inspected monthly and lubricated with general purpose grease when needed.

Gear Box: Gear box oil should be changed after the first 20 hours of operation (see **Figure 15**). Inspect levels periodically and change yearly. Replace gear oil more frequently under heavy use. See **Page 15** for instructions on adding oil.

Replace with 80W-90W gear oil. Fill until oil reaches the top of the filler plug port for correct oil level.

Drive Chain: The drive chain should be inspected and lubricated monthly. Check sprocket, chain and cotter pin during inspection. Use a general purpose grease. Some chains will have master links instead of cotter pins.

Feed Rollers: Regular lubrication of feed rollers is crucial to the operation of your planer. Lubricate every 30 hours of use. Each end of each power feed roller has an oiling port located on the top of the headstock (**Figure 16**). Apply SAE 30W oil, making sure that the lubricant penetrates the bearing.

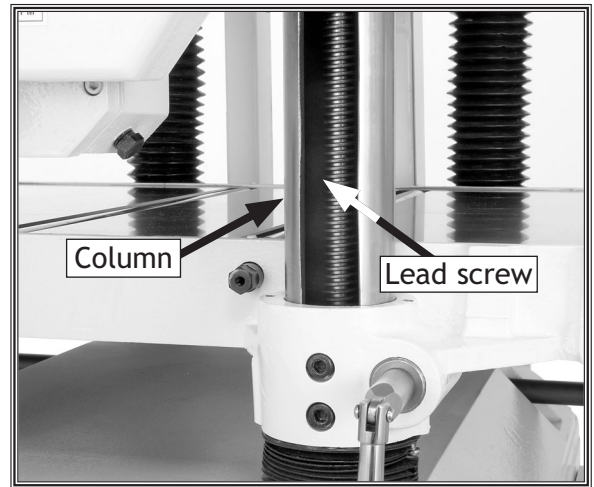

Figure 14. Columns and lead screws (Shown with cover removed).

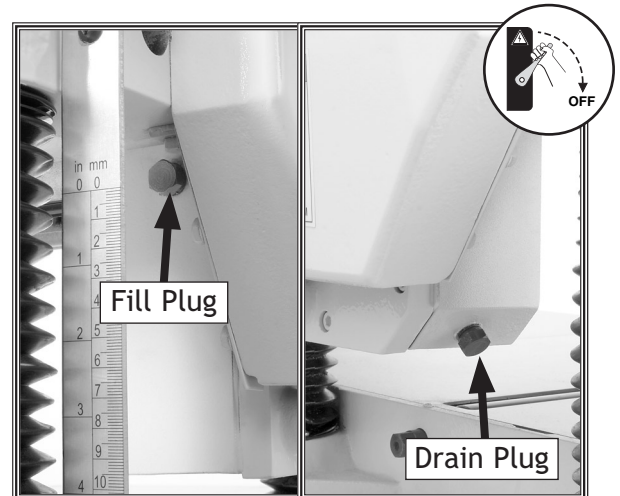
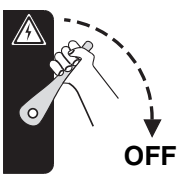

Figure 15. Gearbox oil drain/fill locations.



Figure 16. Feed roller lubrication locations.



! WARNING

SHOCK HAZARD!

Always disconnect power to the machine before lubricating! Failure to do this may result in serious personal injury!

SERVICE

General

This section covers the most common service adjustments or procedures that may need to be made during the life of your machine.

If you require additional machine service not included in this section, please contact Woodstock International Technical Support at (360) 734-3482 or send e-mail to: tech-support@shopfox.biz.

Inspecting Knives

The Model W1747 Planer has a four-knife cutterhead. Because of normal use and wear, the knives must be periodically sharpened, replaced or adjusted. Adjustment from the factory must also be checked prior to use due to possible movement during shipment.

The height of the knives can be easily and quickly inspected with a knife setting gauge or Planer Pal® (Model W1216). This inspection will ensure that the knives are protruding equally and are parallel with the cutterhead body.

To inspect the knives, do these steps:

1. DISCONNECT THE PLANER FROM THE POWER SOURCE!
2. Remove the top cover and dust port.
3. Place a knife gauge on the cutterhead, directly over a knife, as shown in **Figure 17**.
4. Carefully inspect how the gauge touches the cutterhead and the knife.
 - If both outside legs of the gauge sit firmly on the cutterhead and the middle pad just touches the knife, then that knife is protruding the correct amount (.040"). (Repeat this inspection with the other knives.)
 - If the gauge sits firmly on the cutterhead and the knife does not contact the middle pad, or if the knife contacts the middle pad but the feet rock, then reset that knife. (Repeat this inspection with the other knives before resetting.)

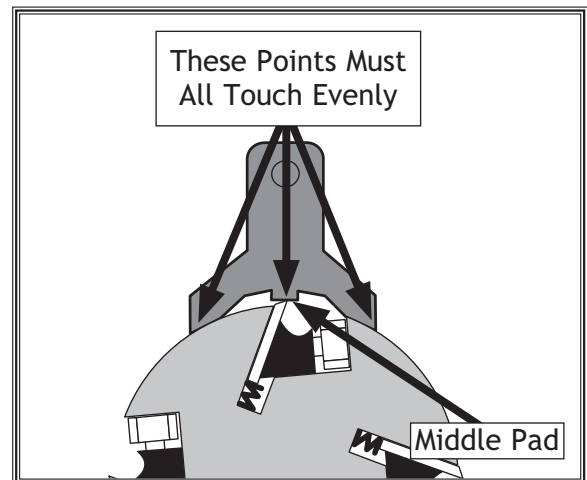
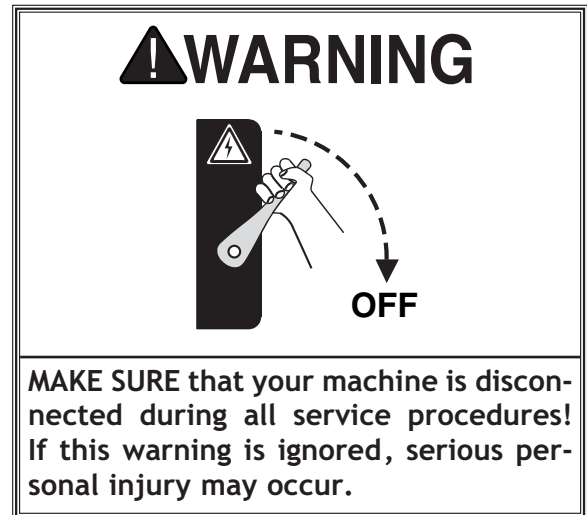

Figure 17. Gauge positioned over cutterhead knife.

Setting/Replacing Knives

Setting the knives correctly is crucial to the proper operation of the planer and is very important in keeping the knives sharp. If one knife protrudes higher than the others, it will do the majority of the work, and thus, dull much faster than the others.

The included knife gauge is designed to set the knives approximately 0.040" higher than the cutterhead. Planer Pal® (Model W1216) can also be used to set the knives.

This planer comes with both jack screws and springs to provide you with two options for cutterhead adjustments (see **Figure 18**).

Note: Only one of these options is needed to set the knives—see **Step 5** for clarification.

To set the knives, do these steps:

1. DISCONNECT THE PLANER FROM THE POWER SOURCE!
2. Remove the top cover and dust port.
3. Remove the belt guard to expose the cutterhead pulley.
4. Rotate the cutterhead pulley to give you good access to one of the knives.

WARNING

Planer knives are dangerous and may cause personal injury. To reduce the risk of being injured, wear leather gloves when handling the knives in the following steps.

5. Using a 12mm wrench, loosen the cutterhead gib bolts, starting in the middle, and alternating back and forth until all of the gib bolts are loose, but not falling out.

Note: If this is the first time you are setting the knives, remove the gib and knife from the cutterhead. The cutterhead comes with both springs and jack screws installed. Decide which adjustment option you are going to use. If you decide to use the jack screws, remove the springs from the cutterhead. If you decide to use the springs, you can just thread the jack screws completely into the cutterhead so they will not get lost. Replace the gib and knife.

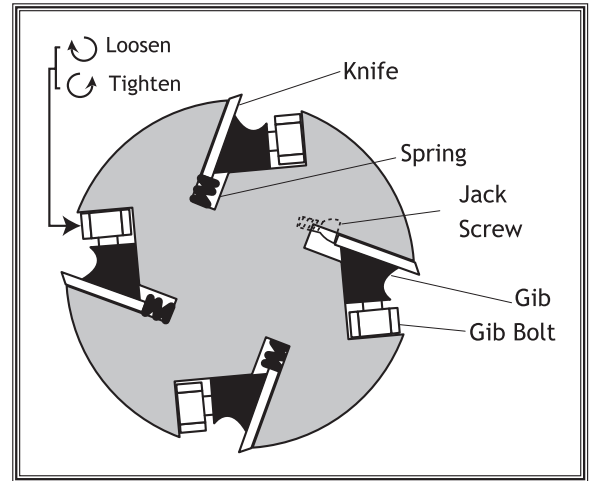

Figure 18. Cutterhead profile diagram.

- Position the knife gauge over the knife as shown in **Figure 17** and loosen the gib bolts until the knife is completely loose.
- Jack Screws**—Using a 3mm hex wrench, find the jack screws through the access holes in the cutterhead (**Figure 19**) and rotate the jack screws to raise or lower the knife. When the knife is set correctly, it will barely touch the middle pad of the knife setting gauge. Snug the gib bolts tight enough to just hold the knife in place. Repeat **Steps 5-7** with the rest of the knives.

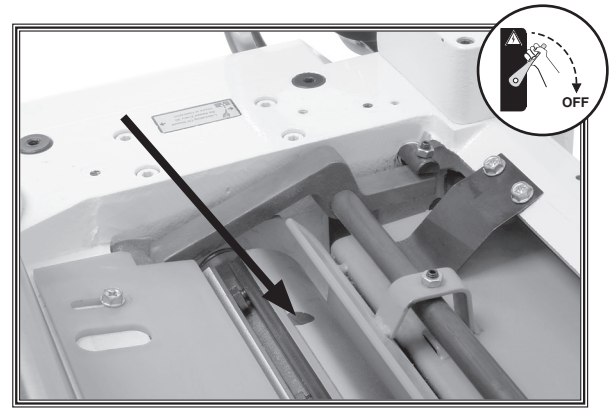

Figure 19. Jack screw access hole.

Springs—Push the knife down with the gauge so that the knife edge touches the middle pad of the gauge. Hold the gauge down and tighten the gib bolts just tight enough to hold the knife in place. Repeat **Steps 5-7** with the rest of the knives.

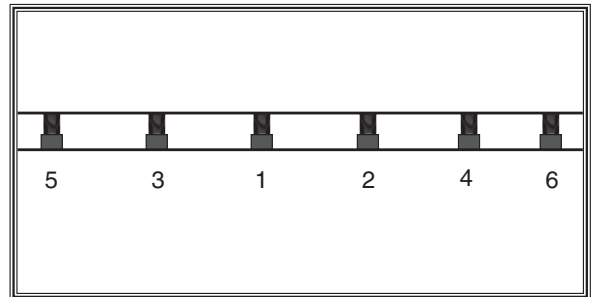

Figure 20. Gib bolt tightening sequence.

- Rotate the cutterhead to the first knife you started with. Slightly tighten all the gib bolts by following the tightening sequence shown in **Figure 20**. Repeat this step on the rest of the knives.
- Final tighten each gib bolt, then reinstall the top cover, dust port and bolt guard.

Chain Tension

The chain drive transfers movement from the handwheel to elevate the table. The chain drive can be adjusted to remove slack if the chain stretches over time or is loosened during table leveling procedures.

To adjust the chain tension, do these steps:

- DISCONNECT THE PLANER FROM THE POWER SOURCE!
- Remove the motor access panel.

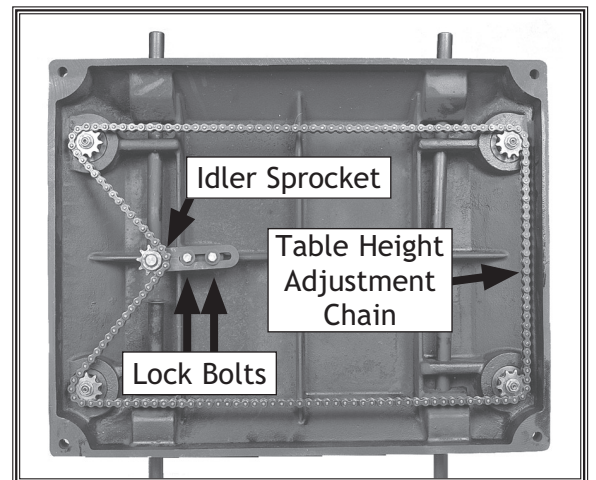

Figure 21. Underside of table.

NOTICE
During the next step, DO NOT let the chain fall off the sprockets—returning it to its proper location without changing the table adjustments will be very difficult and time consuming.

- Loosen the two lock bolts, move the idler sprocket against the chain to tighten it (**Figure 21**) and re-tighten the locking bolts.
- Check chain lubrication. Refer to **MAINTENANCE** on **Page 23** for further details.

Table Parallelism

Table parallelism is critical to the operation of the machine. As such, it is essential that the table is parallel with the cutterhead (within 0.002") from side-to-side, as illustrated in Figure 22.

Maximum Allowable Tolerances:

- Cutterhead to Table Side-to-Side 0.002"
- Headstock to Table Front/Back 0.020"

How the table sits in relation to the headstock from front-to-back is also important (see Figure 23). Because the feed rollers, pressure bar, and chip breaker will be adjusted off the table position, the tolerances on the front-to-back positioning are not as critical as the cutterhead/table side-to-side positioning. Therefore, the maximum allowable tolerance for the front-to-back parallelism is not more than 0.020".

Table Parallelism Inspection

The easiest way to determine if your headstock has a parallelism problem is to plane a workpiece and measure the thickness in multiple locations. If the workpiece is tapered from left-to-right or from front-to-back, then parallelism may be a problem.

Use your Rotacator to further inspect the table parallelism. If you do not have a Rotacator, a wood block and feeler gauges may be used, but extra care must be taken to ensure accuracy. If the table is not within the maximum allowable tolerances, it must be adjusted.

Table Parallelism Adjustments

The table is adjusted by turning the chain sprockets underneath the table for movements over 0.016" or by adjusting how the table is mounted on the columns for movements under 0.016".

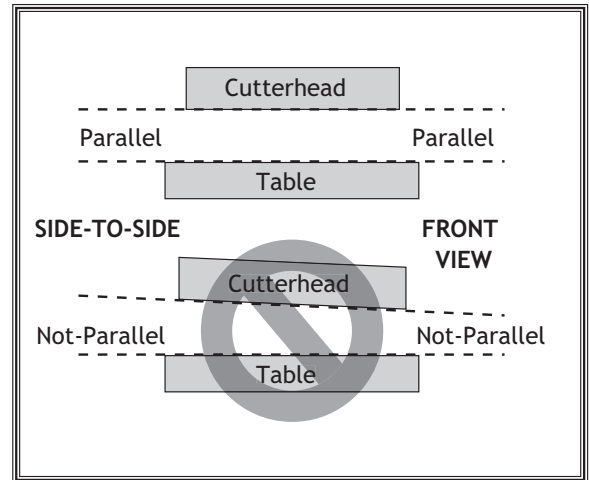

Figure 22. Side-to-side parallelism of table and cutterhead.

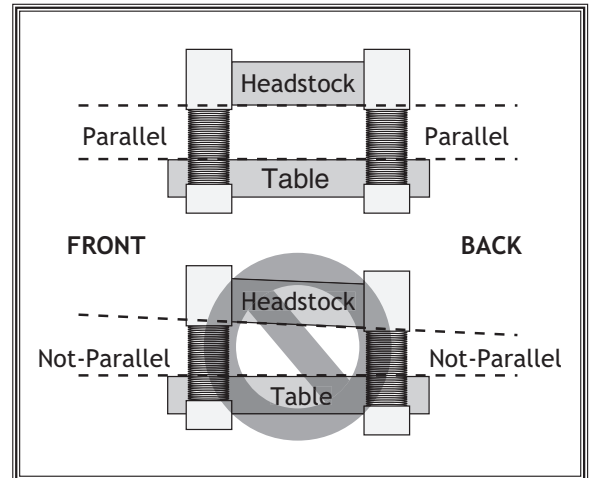

Figure 23. Front-to-back parallelism.

NOTICE

When making adjustments, tighten fasteners after each step to ensure the accuracy of your tests. When adjusting the chain sprockets, keep in mind that if the chain becomes too loose, it will fall off of all the sprockets. Returning it to its proper location will be frustrating and time consuming.

SERVICE

To adjust the table parallelism, do these steps:

1. DISCONNECT THE PLANER FROM THE POWER SOURCE!
2. Remove the motor access panel and locate the chain on the underside of the table.
3. Loosen the lock bolts and idler sprocket (see **Chain Tension** instructions on **Page 28**).
4. Mark the location of one tooth in the sprocket that you are adjusting.
5. Move the chain away from only the sprocket you want to adjust so only that sprocket can be turned independent of the chain.

Note: *If the left side of the table is too high, the left two sprockets will need to be adjusted. Each tooth on the sprocket represents 0.016" of vertical movement as the cogs are turned. Make sure, as you turn the sprockets, to keep an accurate tooth count to ensure that the table is adjusted equally.*

6. Carefully turn the sprocket (clockwise to raise the table; counterclockwise to lower the table) just enough to position the next tooth at the marked location, then fit the chain around sprocket again.
7. Repeat **Steps 4-6** with each sprocket that needs to be adjusted until the table-to-cutterhead clearance is within 0.016" from one side to the other.
8. Make sure the chain is properly fitted on the sprockets, and tighten the idler sprocket and lock bolts.
9. Micro-adjust the table position by loosening the cap screws (**Figure 24**) using a 6mm wrench, and lifting the table upward or downward until the table and cutterhead are in alignment.

Note: *This process may require adjusting the columns on both the left and right hand sides until you find the correct combination.*

10. Replace the motor access panel.

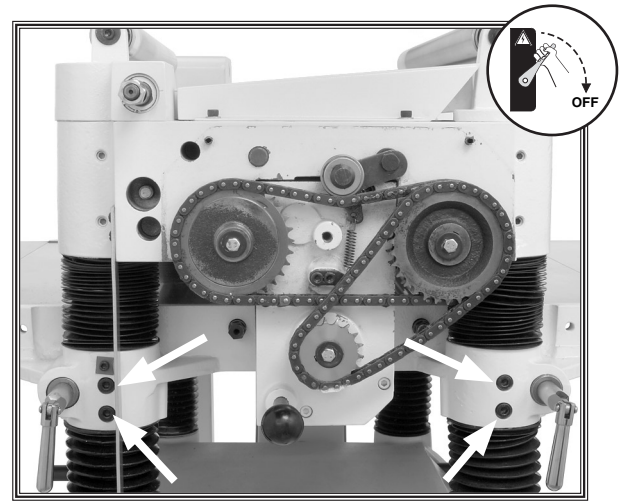

Figure 24. Table micro-adjustment screws.

Rollers, Chip Breaker & Pressure Bar Heights

Distance Below Knife Edge at *BDC:

Infeed Roller	0.040"
Chip Breaker	0.040"
Pressure Bar	0.008"
Outfeed Roller	0.020"

*BDC = Bottom Dead Center (see Figure 25).

To ensure accurate results and make the adjustment process quicker and easier, we recommend using a Rotacator (see Page 21) for these adjustments.

If a Rotacator is not available, a 6' 2x4 cut into two even sized pieces and a feeler gauge set can be used, but care must be taken when jointing the blocks to achieve accurate results.

To set the height of the infeed and outfeed rollers, chip breaker, and pressure bar using a Rotacator, do these steps:

1. DISCONNECT THE PLANER FROM THE POWER SOURCE!
2. Make sure the knives are set correctly with the knife gauge.
3. Lower the table at least 4" below the headstock and lock the table in place.
4. Remove the dust port, top cover, and belt cover.
5. Using your Rotacator, find BDC of any knife edge by slowly rocking the cutterhead pulley back and forth, and set the Rotacator dial to zero, as shown in Figure 26.
6. Place the Rotacator under the right-hand side of the infeed roller, and find bottom dead center on a serrated edge by rocking the infeed roller back and forth.

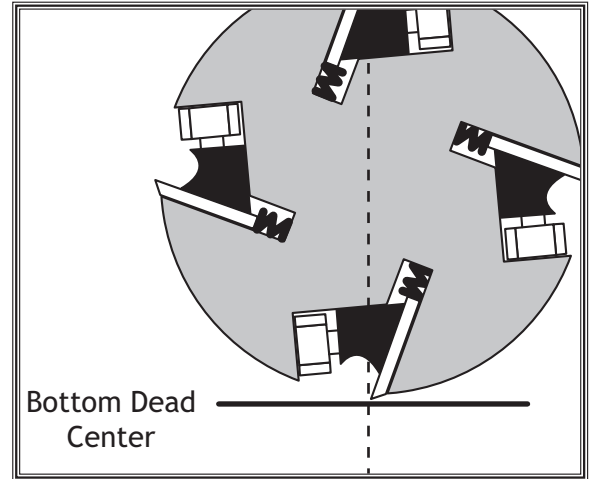

Figure 25. Knife edge at bottom dead center.

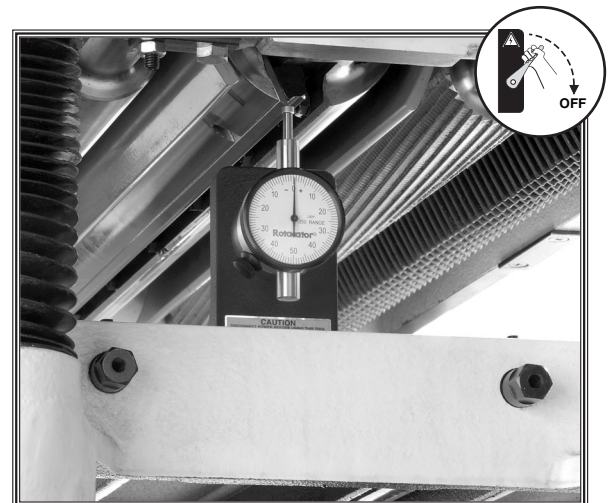

Figure 26. Finding BDC with the Rotacator.

7. Adjust the height of the infeed roller on the same side as the Rotacator to the specification given at the beginning of this procedure, using the zero setting of the Rotacator as a reference point. **Figure 27** shows the jam nut and set screw for adjusting the roller height.
8. Repeat **Steps 6-7** on the left-hand side of the infeed roller.
9. Double-check and micro-adjust both sides of the infeed roller, then carefully lock both sides in place.
10. Using the same zeroed reference on the Rotacator, adjust the height of the outfeed roller, pressure bar, and chip breaker to their given specifications. The adjustment controls for each are shown in **Figures 27, 28, and 29**.

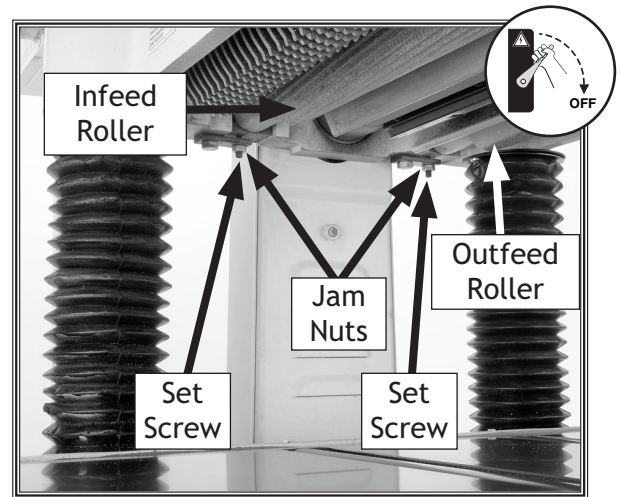

Figure 27. Roller height adjustment controls.

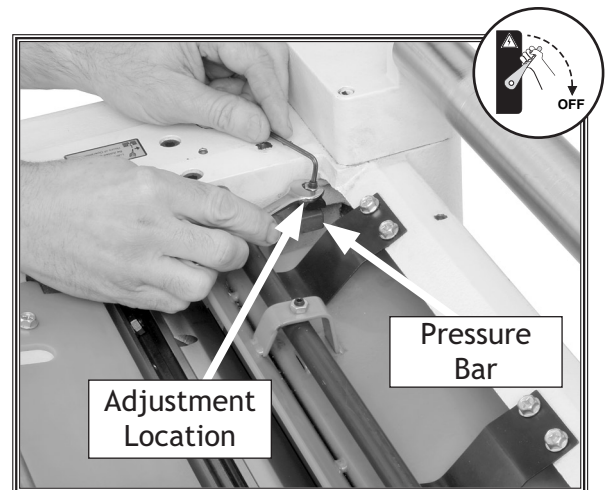

Figure 28. Pressure bar height adjustment controls.

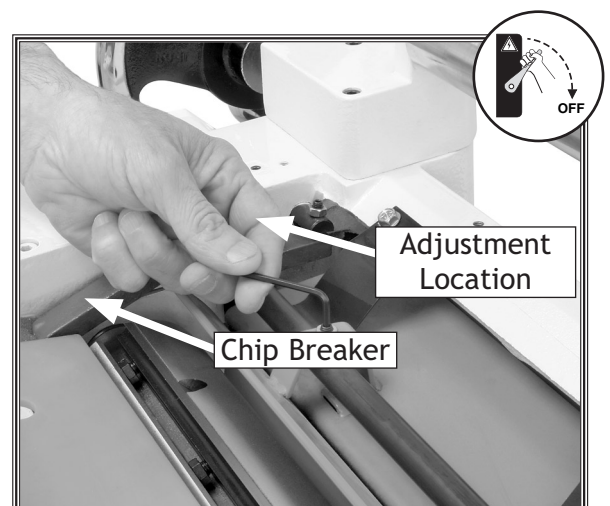

Figure 29. Adjusting chip breaker height.

To adjust the height of the infeed and outfeed rollers, chip breaker and pressure bar using wood blocks and a feeler gauge, do these steps:

1. Build the wood blocks by cutting a straight 6' long 2x4 in half.

Note: Having the wood blocks at an even height is critical to the accuracy of your overall adjustments. For best results, remove board warpage by squaring the 2x4 with a jointer and table saw before cutting in half.

2. DISCONNECT THE PLANER FROM THE POWER SOURCE!
3. Lower the bed rollers below the table.
4. Place one wood block along the left side of the table, and place the other wood block along the right side of the table, as illustrated in **Figure 30**.
5. Remove the dust port, top cover, and belt cover.
6. Adjust the table and use the feeler gauge until you have a 0.040" gap between the edge of a knife at bottom dead center (find by rocking cutterhead pulley) and the wood blocks.
7. Lock the table height in place, as the wood blocks will now be your reference points for the rest of the adjustments.
8. Loosen the infeed roller adjustment jam nuts (**Figure 32**) and turn the adjustment set screws on each end to raise the feed roller above the wood block (if necessary), then bring it back down so it just touches the wood block on both sides.
9. Lock the infeed roller adjustment set screws in place with the jam nuts, making sure they do not move while tightening.
10. Without moving the table, adjust the chip breaker (**Figure 29**), pressure bar (**Figure 28**), and outfeed roller (**Figure 27**) in the same manner, using the wood blocks as your reference point.
11. When you are finished with the adjustments, replace the top cover, dust port, and belt cover.

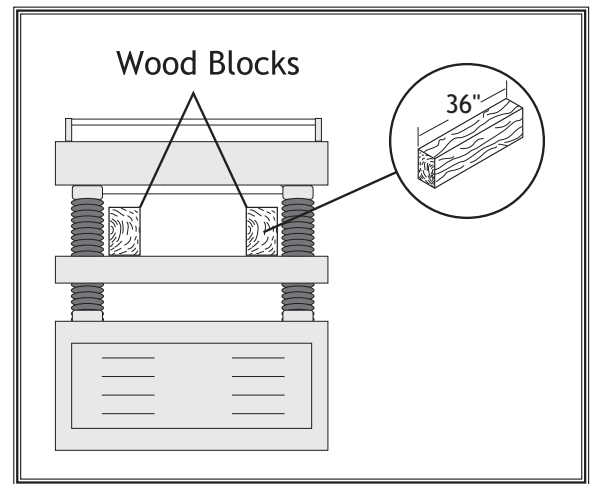

Figure 30. Wood blocks on table.

Spring Tension

Roller spring tension must be adjusted so that roller pressure is uniform. Roller spring tension will vary, depending on the type of wood you plane. This is usually determined from trial-and-error.

Generally speaking, less spring tension is more forgiving on workpieces. Therefore, if you primarily plane milled lumber with relatively consistent surfaces, you can get away with having less spring tension. Likewise, if you primarily plane rough lumber with inconsistent surface heights, more spring tension is a must to keep the workpiece feeding through the planer without stopping.

If workpieces regularly stop feeding during operation, it may be a sign of weak spring tension.

To adjust roller spring tension, do these steps:

1. Locate the four tension screws located on the top of the planer, as shown in **Figure 31**.
2. Using a 6mm hex wrench, adjust tension screws #1-#3 so that they protrude $\frac{1}{8}$ " above the headstock.
3. Adjust tension screw #4 so that it protrudes $\frac{5}{16}$ " above the headstock.

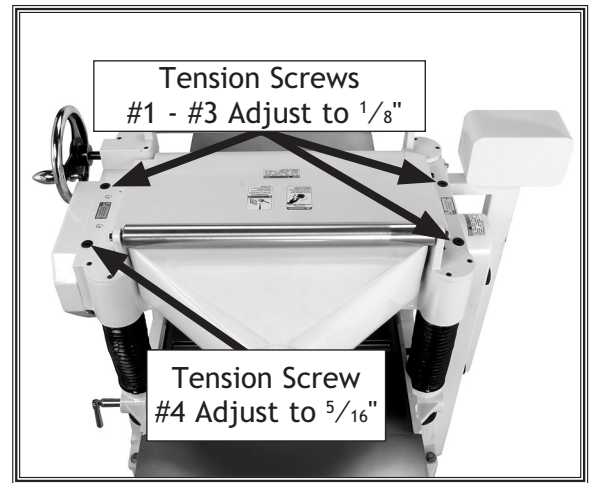

Figure 31. Tension screw locations and adjustments.

Chip Deflector Positioning

The chip deflector keeps chips from falling onto the outfeed roller.

Chip Deflector Gap Setting

If Planer Used w/Dust Collector..... $\frac{1}{4}$ "
 If Planer Used w/o Dust Collector $\frac{1}{16}$ "

To adjust the deflector position, do these steps:

1. DISCONNECT THE PLANER FROM THE POWER SOURCE!
2. Remove the dust port and top cover.
3. Loosen the chip deflector mounting bolts (see **Figure 32**).
4. Make sure the deflector is beveled toward the cutterhead. Move the deflector until the edge is the correct distance (given above) from the closest knife.
5. Rotate the cutterhead to ensure clearance by turning the cutterhead pulley.
6. Re-tighten the mounting bolts and return the top cover and dust port to the planer.

Scale Calibration

The scale can be adjusted for accuracy. The machine will need to be run to make proper adjustments.

To calibrate the scale, do these steps:

1. Set the table to the approximate thickness of your test lumber. Measure the lumber with calipers to determine its exact thickness.
2. Move the table to $\frac{1}{16}$ " under the thickness of your lumber and feed your test board through the planer.
3. Turn the handwheel one full rotation and run the board through once more. Turn the board over and repeat.
4. Re-measure the board and compare your results with the scale. If there is a discrepancy, loosen the screws (see **Figure 33**) and adjust as necessary.

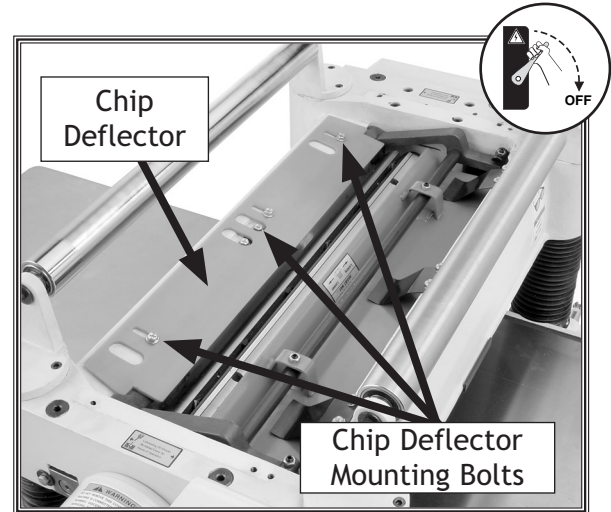

Figure 32. Chip deflector and mounting bolts.



Figure 33. Depth scale adjustment screws.

Anti-Kickback Fingers

The Model W1747 provides an anti-kickback system as a safety feature. The anti-kickback fingers hang from a rod suspended across the cutter headstock. The anti-kickback fingers should be inspected regularly.

Check the fingers (**Figure 34**) to ensure that they swing freely and easily. If the fingers do not swing freely and easily, clean them with a wood resin solvent.

WARNING

Proper operation of the anti-kickback fingers is essential for the safe operation of this machine. Failure to ensure that they are working properly could result in serious operator injury.

Do not apply oil or other lubricants to the anti-kickback fingers. Oil or grease will attract dust, restricting the free movement of the fingers.



Figure 34. Anti-kickback fingers.

Pulley Alignment

Proper pulley alignment (see **Figure 35**) prevents premature belt wear. The pulleys are properly aligned when they are parallel and in the same plane as each other. Use a straightedge on the edge of the pulleys to judge alignment.

Should you find that the pulleys are out of alignment, do these steps:

1. DISCONNECT THE PLANER FROM THE POWER SOURCE!
2. Remove the motor access panel, the V-belt cover, and loosen the belt tension (**Page 24**).
3. Using a 12mm wrench, loosen the motor mount fasteners shown in **Figure 36** just enough to allow the motor to be repositioned.
4. Slide the motor as required to align the pulleys.
5. Re-tighten the motor mount fasteners carefully to assure that the tightening process does not move the motor.
6. Re-tension the V-belts.
7. Replace the belt cover and motor access panel.

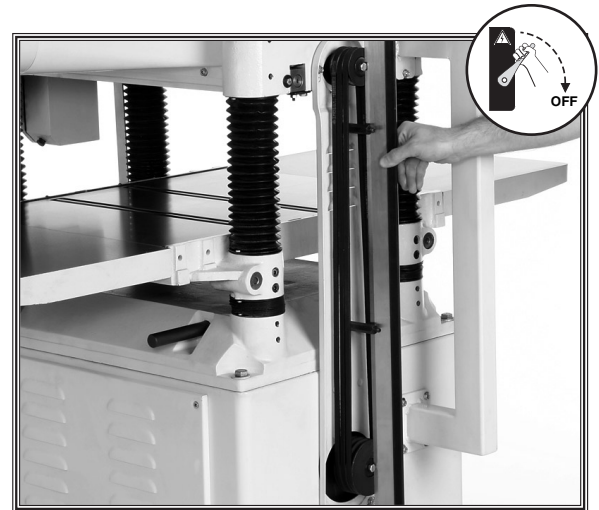

Figure 35. Checking belt alignment.

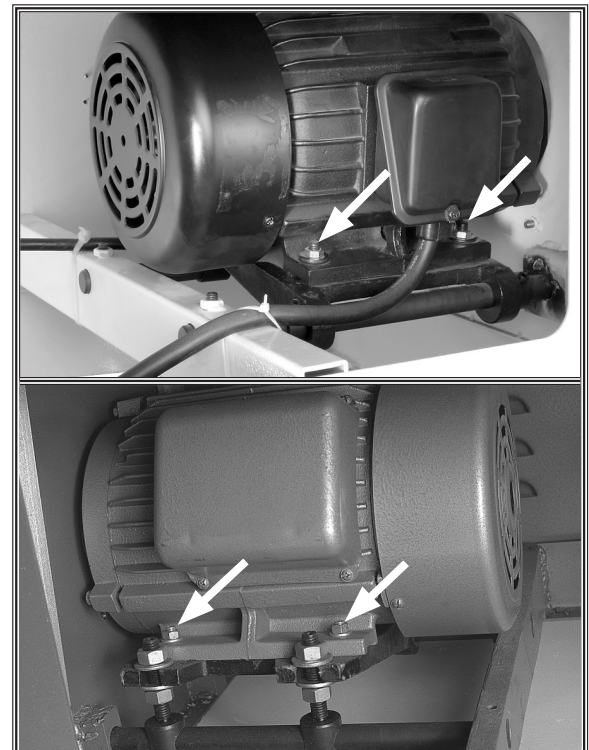

Figure 36. Motor mount fasteners.

W1747 Electrical Components

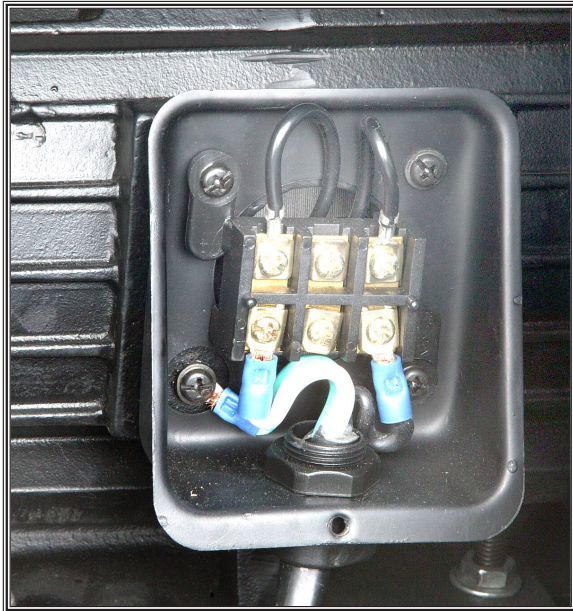

Figure 37. W1747 motor junction box.

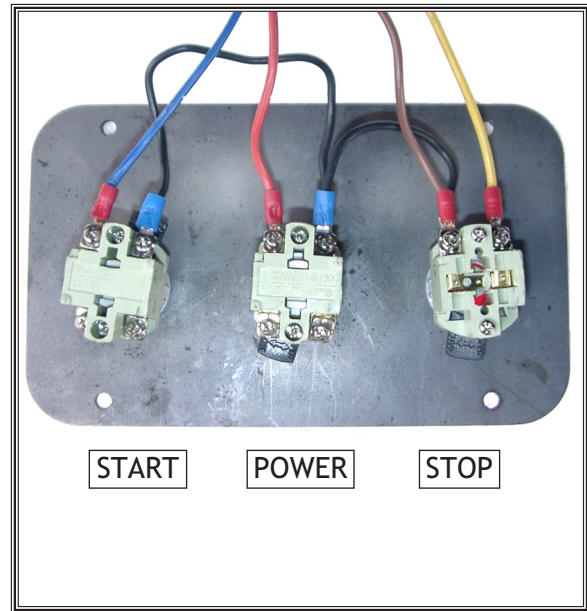

Figure 38. W1747 control panel.

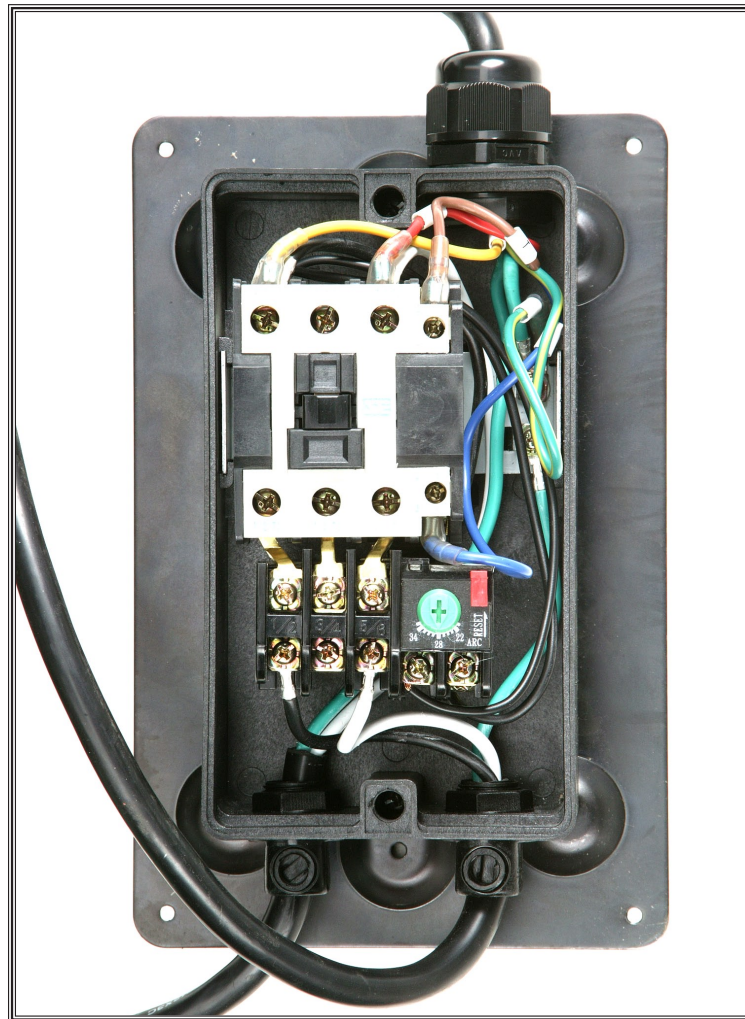
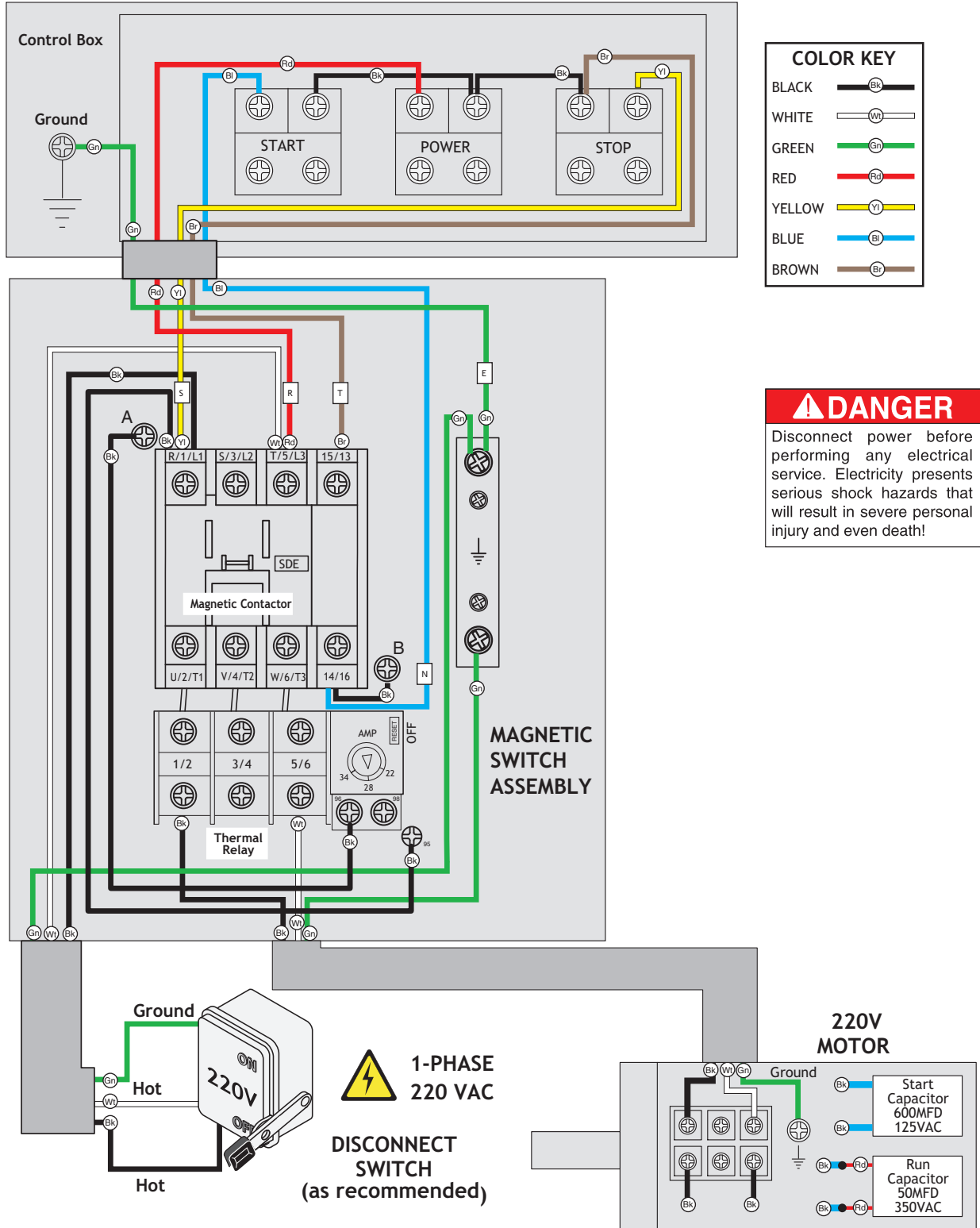

Figure 39. W1747 magnetic switch assembly.

W1747 Wiring Diagram

CONTROL PANEL (viewed from behind)



SERVICE

Troubleshooting

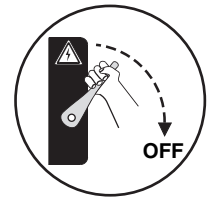

This section covers the most common problems and corrections with this type of machine. **WARNING! DO NOT** make any adjustments until power is disconnected and moving parts have come to a complete stop!

Motor & Machine Operation

PROBLEM	POSSIBLE CAUSE	CORRECTIVE ACTION
Motor will not start.	<ol style="list-style-type: none"> Emergency stop button depressed. Thermal protection circuit. Breaker amperage is set too low. Open circuit in motor or loose connections. Start capacitor at fault. 	<ol style="list-style-type: none"> Rotate clockwise until it pops out/replace. Unplug machine, open magnetic switch cover, turn amperage dial on Thermal Protection Circuit Breaker to a higher amperage setting. Inspect all lead connections on motor for loose or open connections. Replace start capacitor.
Fuses or circuit breakers blow.	<ol style="list-style-type: none"> Short circuit in line cord or plug. 	<ol style="list-style-type: none"> Repair or replace cord or plug for damaged insulation and shorted wires.
Motor fails to develop full power (output of motor decreases rapidly with decrease in voltage at motor terminals).	<ol style="list-style-type: none"> Undersized wires or circuits too long. Motor run capacitor at fault. 	<ol style="list-style-type: none"> Increase wire sizes or reduce length of the circuit. Replace run capacitor.
Motor overheats.	<ol style="list-style-type: none"> Motor overloaded during operation. Air circulation through the motor restricted. 	<ol style="list-style-type: none"> Reduce cutting load; take lighter cuts. Clean out motor to provide normal air circulation.
Motor stalls or shuts off during a cut.	<ol style="list-style-type: none"> Motor overloaded during operation. Thermal protection circuit. Breaker amperage is set too low. Short circuit in motor or loose connections. Circuit breaker tripped. 	<ol style="list-style-type: none"> Reduce cutting load; take lighter cuts. Unplug machine, open magnetic switch cover, turn amperage dial on Thermal Protection Circuit Breaker to a higher amperage setting. Repair or replace connections on motor for loose or shorted terminals or worn insulation. Install correct circuit breaker; reduce # of machines running on that circuit.
Cutterhead slows or squeals when cutting, especially on start-up.	<ol style="list-style-type: none"> V-belt loose. V-belt worn out. 	<ol style="list-style-type: none"> Tighten V-belt (Page 24). Replace V-belt (Page 24).
Loud repetitious noise coming from machine.	<ol style="list-style-type: none"> Pulley setscrews or keys are missing or loose. Motor fan is hitting the cover. V-belts are damaged. 	<ol style="list-style-type: none"> Inspect keys and setscrews. Replace or tighten if necessary. Adjust fan cover mounting position, tighten fan, or shim fan cover. Replace V-belts (Page 24).
Vibration when running or cutting.	<ol style="list-style-type: none"> Loose or damaged knife. Damaged V-belt. Worn cutterhead bearings. 	<ol style="list-style-type: none"> Tighten or replace knife (Page 27). Replace V-belt (Page 24). Check/replace cutterhead bearings.

Cutting

PROBLEM	POSSIBLE CAUSE	CORRECTIVE ACTION
<p>Excessive snipe (gouge in the end of the board that is uneven with the rest of the cut).</p> <p>Note: A small amount of snipe is inevitable with all types of planers. The key is minimizing it as much as possible.</p>	<ol style="list-style-type: none"> One or both of the bed rollers are set too high. Outfeed extension slopes down or is not level with the main table. Chipbreaker or pressure bar set too low. Workpiece is not supported as it leaves the planer. 	<ol style="list-style-type: none"> Lower the bed rollers (Page 20). Shim the outfeed extension wing level with the main table. Raise the height of the chipbreaker or pressure bar (Page 31). Hold the workpiece up slightly as it leaves the outfeed end of the planer.
Workpiece stops/slows in the middle of the cut.	<ol style="list-style-type: none"> Taking too heavy of a cut. One or both of the bed rollers are set too low or too high. Chipbreaker or pressure bar set too low. Feed rollers set too low or too high. Table not parallel with headstock. Pitch and glue build up on planer components. 	<ol style="list-style-type: none"> Take a lighter cut. Lower/raise the bed rollers (Page 20). Raise the height of the chipbreaker or pressure bar (Page 31). Adjust the feed rollers to the correct height (Page 31). Adjust the table so it is parallel to the headstock. Clean the internal cutterhead components with a pitch/resin dissolving solvent.
Chipping (consistent pattern).	<ol style="list-style-type: none"> Knots or conflicting grain direction in wood. Nicked or chipped knife. Feeding workpiece too fast. Taking too deep of a cut. Misaligned chipbreaker. 	<ol style="list-style-type: none"> Inspect workpiece for knots and grain direction; only use clean stock. Replace the affected knife (Page 27). Slow down the feed rate (Page 19). Take a smaller depth of cut. (Always reduce cutting depth when surface planing or working with hard woods.) Adjust both sides of the chipbreaker to the correct height (Page 35).
Fuzzy grain.	<ol style="list-style-type: none"> Wood may have high moisture content or surface wetness. Dull knives. 	<ol style="list-style-type: none"> Check moisture content and allow to dry if moisture is too high. Rotate/replace the knives (Page 27) or have them professionally sharpened.
Long lines or ridges that run along the length of the board	<ol style="list-style-type: none"> Nicked or chipped knife(s). 	<ol style="list-style-type: none"> Replace the knives (Page 27) or have them professionally sharpened.
Uneven knife marks, wavy surface, or chatter marks across the face of the board.	<ol style="list-style-type: none"> Feeding workpiece too fast. Chipbreaker or pressure bar set unevenly. Knives not installed evenly. Worn cutterhead bearings. 	<ol style="list-style-type: none"> Slow down the feed rate. Adjust the height of the chipbreaker or pressure bar (Page 31). Adjust the knives with the knife gauge (Page 27). Replace cutterhead bearings.
Glossy surface.	<ol style="list-style-type: none"> Knives are dull. Feed rate too slow. Cutting depth too shallow. 	<ol style="list-style-type: none"> Rotate/replace the knives (Page 27) or have them professionally sharpened. Increase the feed rate (Page 19). Increase the depth of cut.
Chip Marks (inconsistent pattern).	<ol style="list-style-type: none"> Chips aren't being properly expelled from the cutterhead. 	<ol style="list-style-type: none"> Use a dust collection system; adjust the chip deflector in or out depending on your setup (Page 35).

Headstock Assembly Parts Breakdown

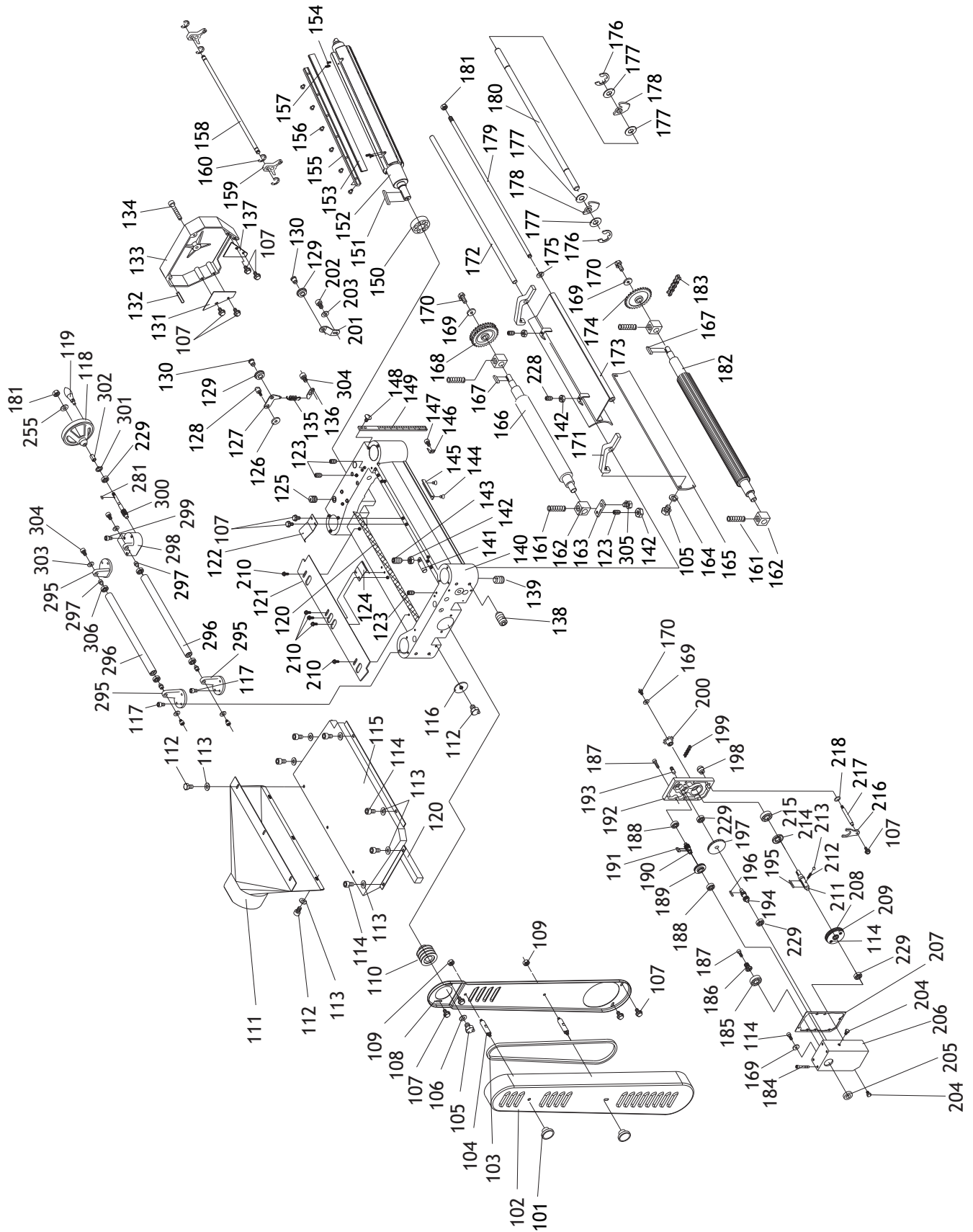

PARTS

Headstock Assembly Parts List

REF	PART #	DESCRIPTION
101	X1747101	ROUND KNOB 5/16-18
102	X1747102	V-BELT COVER
103	XPVM59	V-BELT M59 3L590
104	X1747104	STUD
105	XPB09M	HEX BOLT M8-1.25 X 20
106	X1747106	FENDER WASHER 8MM
107	XPFS02M	FLANGE SCREW M6-1 X 12
108	X1747108	PULLEY GUARD
109	XPNO2	HEX NUT 5/16-18
110	X1747110	CUTTERHEAD PULLEY
111	X1747111	DUST HOOD
112	XPSB26M	CAP SCREW M6-1 X 12
113	XPW03M	FLAT WASHER 6MM
114	XPSB26M	CAP SCREW M6-1 X 12
115	X1747115	UPPER COVER
116	XPW03M	FLAT WASHER 6MM
117	XPSB01M	CAP SCREW M6-1 X 16
118	X1747118	HAND WHEEL
119	X1747119	HANDLE M12-1.75
120	X1747120	SPONGE STRIP
121	X1747121	CHIP DEFLECTOR
122	X1747122	SPRING PLATE
123	XPSS11M	SET SCREW M6-1 X 16
124	X1747124	SPRING PLATE
125	X1747125	SPECIAL OILER SET SCREW
126	XPW01M	FLAT WASHER 8MM
127	X1747127	BRACKET
128	X1747128	SHAFT
129	X1747129	IDLER PULLEY
130	X1747130	SHAFT
131	X1747131	RIGHT BACKING PLATE
132	XPRP07M	ROLL PIN 6 X 20
133	X1747133	CHAIN DRIVE COVER
134	XPSB12M	CAP SCREW M8-1.25 X 40
135	X1747135	EXTENSION SPRING
136	X1747136	HANGER
137	X1747137	LEFT BACKING PLATE
138	XPSS13M	SET SCREW M10-1.5 X 12
139	XPSS14M	SET SCREW M8-1.25 X 12
140	X1747140	HEAD CASTING

REF	PART #	DESCRIPTION
141	X1747141	SHAFT
142	XPNO1M	HEX NUT M6-1
143	XPSS25M	SET SCREW M6-1 X 20
144	XPFH30M	FLAT HD SCR M5-.8 X 8
145	X1747145	DEPTH LIMITER
146	X1747146	INDICATOR
147	XPSB50M	CAP SCREW M5-.8 X 10
148	XPS14M	PHLP HD SCR M6-1 X 12
149	X1747149	SCALE
150	XP6206	BALL BEARING 6206ZZ
151	XPK129M	KEY 8 X 8 X 36
152	X1747152	CUTTERHEAD
153	D3097	BLADES SET OF 4 FOR 20" PLANER
154	X1747154	JACK SCREW M5-.8 X 12
155	X1747155	KNIFE GIB
156	X1747156	GIB SCREW M8-1.25 X 10
157	X1747157	SPRING
158	X1747158	KNIFE GAUGE BAR
159	X1747159	KNIFE GAUGE
160	XPEC10M	E-CLIP 9MM
161	X1747161	COMPRESSION SPRING
162	X1747162	BUSHING BLOCK
163	X1747163	PLATE
164	XPLW04M	LOCK WASHER 8MM
165	X1747165	PRESSURE BAR
166	X1747166	OUTFEED ROLLER
167	XPK01M	KEY 5 X 5 X 22
168	X1747168	SPROCKET
169	XPW03M	FLAT WASHER 6MM
170	XPB83M	HEX BOLT M6-1 X 16
171	X1747171	BRACKET
172	X1747172	SHAFT
173	X1747173	CHIP BREAKER
174	X1747174	SPROCKET
175	XPR03M	EXT RETAINING RING 12MM
176	XPEC05M	E-CLIP 15MM
177	X1747177	SPACER
178	X1747178	ANTI-KICKBACK FINGER
179	X1747179	LOCKING ROD
180	X1747180	SHAFT

REF	PART #	DESCRIPTION
181	XPN09M	HEX NUT M12-1.75
182	X1747182	INFEED ROLLER
183	X1747183	CHAIN
184	XPSB05M	CAP SCREW M8-1.25 X 50
185	XP6204	BALL BEARING 6204ZZ
186	X1747186	GEAR
187	XPSB06M	CAP SCREW M6-1 X 25
188	XP6201	BALL BEARING 6201
189	X1747189	GEAR
190	X1747190	GEAR AND SHAFT
191	XPK10M	KEY 5 X 5 X 12
192	X1747192	GEAR BOX COVER
193	X1747193	PIN
194	X1747194	SHAFT
195	XPK11M	KEY 6 X 6 X 40
196	XPK06M	KEY 5 X 5 X 10
197	X1747197	GEAR
198	X1747198	BALL KNOB 3/8-16
199	X1747199	CHAIN
200	X1747200	SPROCKET
201	X1747201	BRACKET
202	XPSB48M	CAP SCREW M6-1 X 35
203	XPW03M	FLAT WASHER 6MM
204	X1747204	OIL PLUG
205	X1747205	OIL SEAL
206	X1747206	GEAR BOX
207	X1747207	GASKET

REF	PART #	DESCRIPTION
208	X1747208	GEAR
209	X1747209	GEAR
210	XPFS14M	FLANGE SCREW M6-1 X 16
211	X1747211	SHAFT
212	X1747212	COMPRESSION SPRING
213	X1747213	BALL 6MM
214	X1747214	OIL SEAL 25 X 47 X 6
215	XP6204	BALL BEARING 6204ZZ
216	X1747216	CLUTCH
217	X1747217	CLUTCH HANDLE
218	X1747218	O-RING 12MM
228	XPSS04M	SET SCREW M6-1 X 12
229	XP6201	BALL BEARING 6201
255	XPW06M	FLAT WASHER 12MM
281	XPK05M	KEY 4 X 4 X 10
295	X1747295	ROLLER STAND
296	X1747296	ROLLER
297	X1747297	ROLLER SHAFT
298	X1747298	WORM GEAR BOX
299	XPSB37M	CAP SCREW M6-1 X 50
300	X1747300	WORM GEAR
301	XPR29M	INT RETAINING RING 32MM
302	X1747302	COLLAR
303	XPW03M	FLAT WASHER 6MM
304	XPSB04M	CAP SCREW M6-1 X 10
305	XPSB76M	CAP SCREW M8-1.25 X 18
306	XP6202	BALL BEARING 6202ZZ

Table, Base, and Columns Parts Breakdown

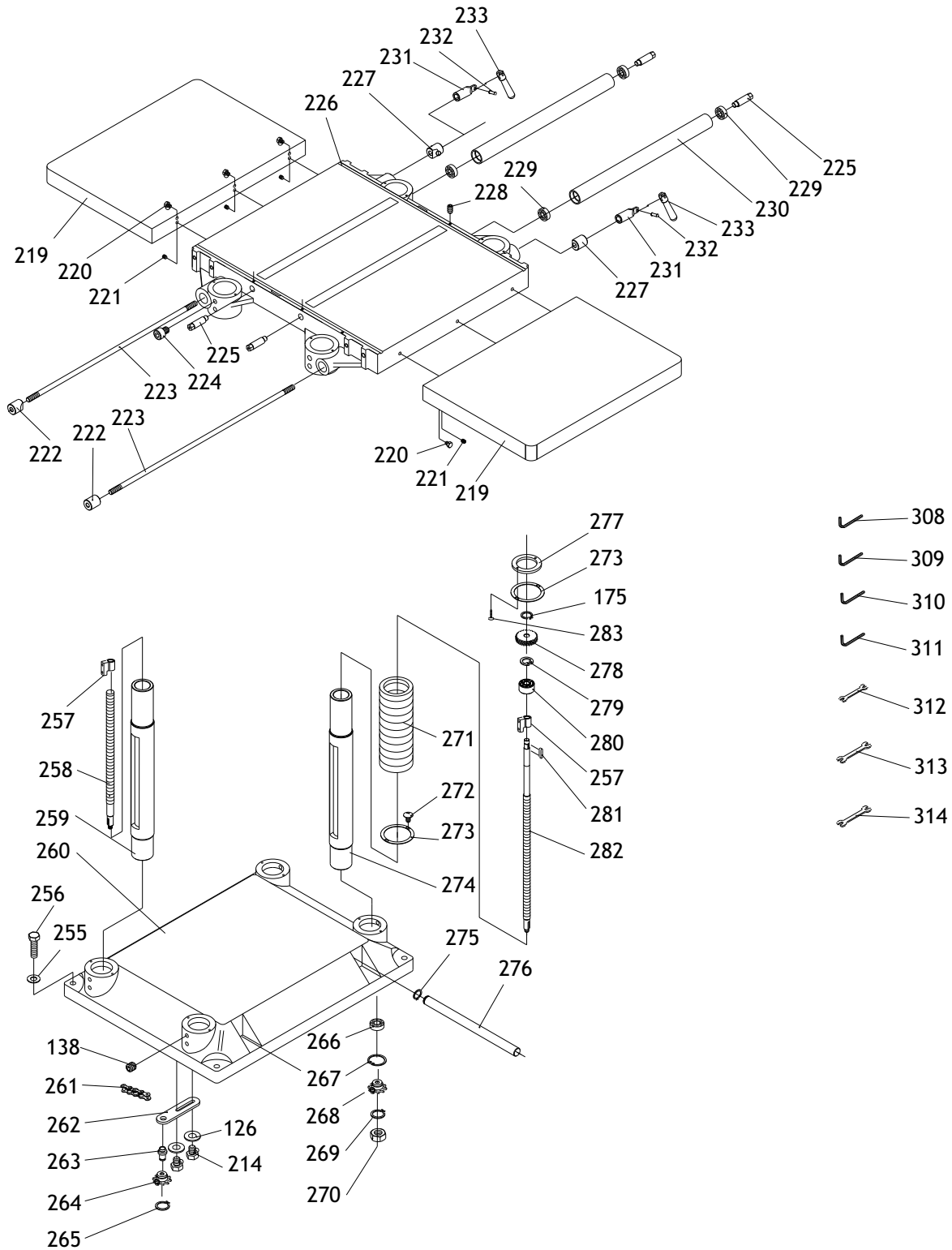

Table, Base, and Columns Parts List

REF	PART #	DESCRIPTION
126	XPW01M	FLAT WASHER 8MM
138	XPSS13M	SET SCREW M10-1.5 X 12
175	XPR03M	EXT RETAINING RING 12MM
214	X1747214	OIL SEAL 25 X 47 X 6
219	X1747219	EXTENSION WING
220	XPB07M	HEX BOLT M8-1.25 X 25
221	XPSS09M	SET SCREW M8-1.25 X 20
222	X1747222	LOCKING BOLT
223	X1747223	LOCK BAR
224	XPSB11M	CAP SCREW M8-1.25 X 16
225	X1747225	SHAFT
226	X1747226	MIDDLE TABLE
227	X1747227	GIB
228	XPSS04M	SET SCREW M6-1 X 12
229	XP6201	BALL BEARING 6201
230	X1747230	TABLE ROLLER
231	X1747231	HANDLE NUT M12-1.75
232	X1747232	PIN
233	X1747233	LOCKING HANDLE
255	XPW06M	FLAT WASHER 12MM
256	XPB33M	HEX BOLT M12-1.75 X 50
257	X1747257	LEAD SCREW NUT
258	X1747258	LEAD SCREW (SHORT)
259	X1747259	COLUMN
260	X1747260	BASE
261	X1747261	CHAIN
262	X1747262	IDLER BRACKET
263	X1747263	SHAFT

REF	PART #	DESCRIPTION
264	X1747264	SPROCKET
265	XPR05M	EXT RETAINING RING 15MM
266	XP6202	BEARING 6202ZZ
267	XPR21M	INT RETAINING RING 35MM
268	X1747268	SPROCKET
269	XPW04M	FLAT WASHER 10MM
270	XPNO8M	HEX NUT M10-1.25
271	X1747271	EXPANSION BAND
272	XPS09M	PHLP HD SCR M5-.8 X 10
273	X1747273	PIPE BAND
274	X1747274	COLUMN
275	XPR18M	EXT RETAINING RING 17MM
276	X1747276	CRANE POST
277	X1747277	PLATE
278	X1747278	WORM GEAR
279	XPR22M	INT RETAINING RING 38MM
280	X1747280	BUSHING
281	XPK05M	KEY 4 X 4 X 10
282	X1747282	LEAD SCREW (LONG)
283	XPS05M	PHLP HD SCR M5-.8 X 8
308	XPAW03M	HEX WRENCH 3MM
309	XPAW04M	HEX WRENCH 4MM
310	XPAW05M	HEX WRENCH 5MM
311	XPAW06M	HEX WRENCH 6MM
312	XPWR810	COMBO WRENCH 8 X 10
313	XPWR1214	COMBO WRENCH 12 X 14
314	XPWR1719	COMBO WRENCH 17 X 19

Stand/Motor Assembly Parts Breakdown

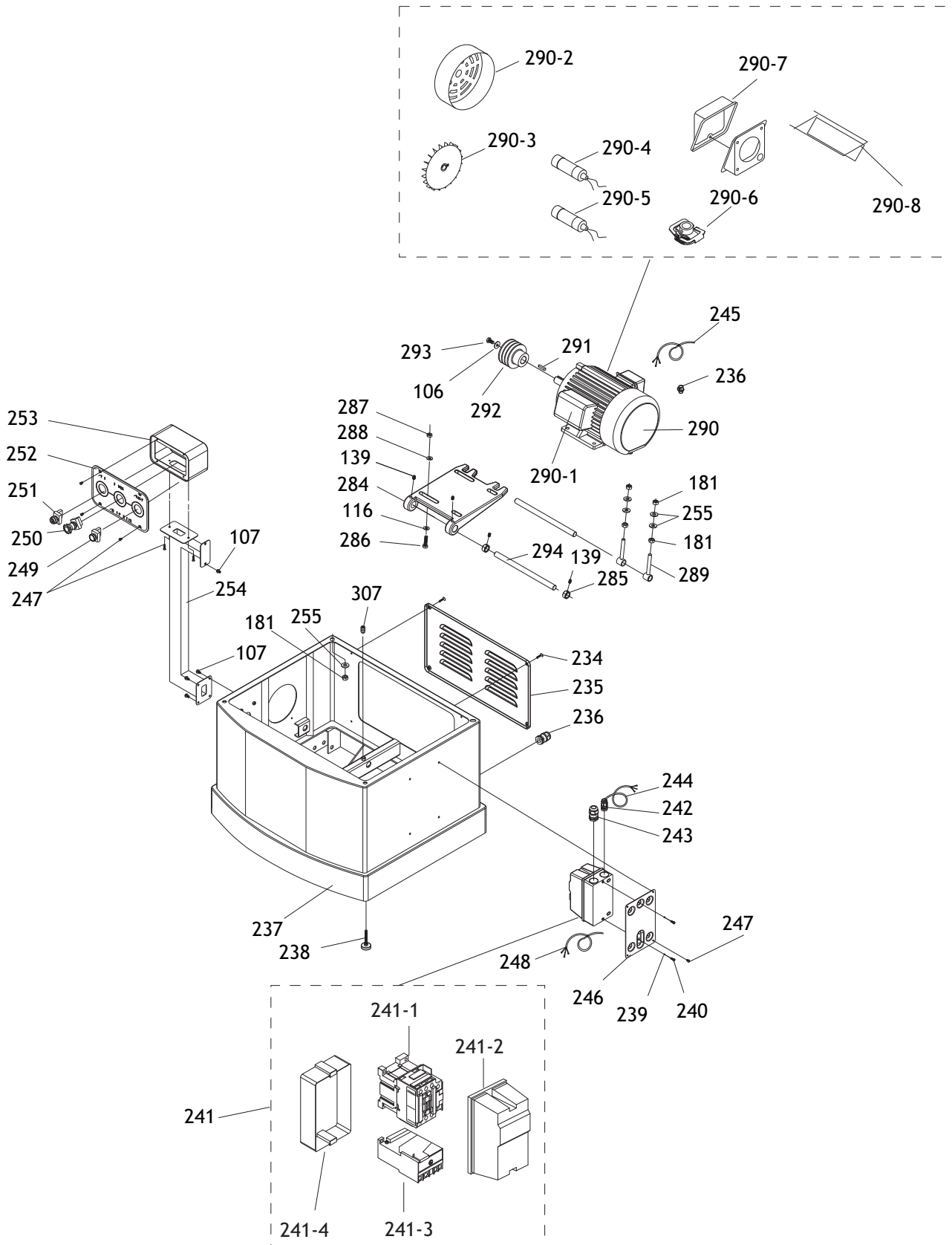

Stand/Motor Assembly Parts List

REF	PART #	DESCRIPTION
106	X1747106	FENDER WASHER 8MM
107	XPFS02M	FLANGE SCREW M6-1 X 12
116	XPW03M	FLAT WASHER 6MM
139	XPSS14M	SET SCREW M8-1.25 X 12
181	XPNO9M	HEX NUT M12-1.75
234	XPFH06M	FLAT HD SCR M6-1 X 20
235	X1747235	COVER
236	X1747236	STRAIN RELIEF
237	X1747237	CABINET STAND
238	X1747238	FOOT
239	XPTLW02M	EXT TOOTH WASHER 5MM
240	XPS20M	PHLP HD SCR M5-.8 X 15
241	X1747241	MAGNETIC SWITCH ASSEMBLY
241-1	X1747241-1	CONTACTOR
241-2	X1747241-2	MAG SWITCH FRONT COVER
241-3	X1747241-3	THERMAL OVERLOAD RELAY
241-4	X1747241-4	MAG SWITCH BACK COVER
242	X1747242	STRAIN RELIEF
243	X1747243	STRAIN RELIEF
244	X1747244	POWER CORD 10AWG X 3C
245	X1747245	MOTOR CORD 10AWG X 3C
246	X1747246	SWITCH PLATE
247	XPS09M	PHLP HD SCR M5-.8 X 10
248	X1747248	SWITCH CORD 18AWG X4C
249	X1747249	START SWITCH
250	X1747250	STOP SWITCH

REF	PART #	DESCRIPTION
251	X1747251	INDICATOR LIGHT (RED)
252	X1747252	SWITCH PLATE
253	X1747253	SWITCH BOX
254	X1747254	SWITCH ELBOW BRACKET
255	XPW06M	FLAT WASHER 12MM
284	X1747284	MOTOR BRACKET
285	X1747285	COLLAR
286	XPB15M	HEX BOLT M8-1.25 X 40
287	XPNO3M	HEX NUT M8-1.25
288	XPW01M	FLAT WASHER 8MM
289	X1747289	ADJUSTABLE BOLT M12-1.75
290	X1747290	5 HP MOTOR 220V 1-PH
290-1	X1747290-1	CAPACITOR COVER
290-2	X1747290-2	MOTOR FAN COVER
290-3	X1747290-3	MOTOR FAN
290-4	X1747290-4	S. CAPACITOR 600MFD/125VAC
290-5	X1747290-5	R. CAPACITOR 50MFD/350VAC
290-6	X1747290-6	CENTRIFUGAL SWITCH
290-7	X1747290-7	JUNCTION BOX
290-8	X1747290-8	MOTOR LABEL
291	XPK12M	KEY 5 X 5 X 30
292	X1747292	MOTOR PULLEY
293	X1747293	NYLOCK HEX BOLT M8-1.25 X 20
294	X1747294	BAR
307	XPSS09M	SET SCREW M8-1.25 X 20

Warning Label Placement and Parts List

⚠️ WARNING

Safety labels warn about machine hazards and how to prevent machine damage or injury. The owner of this machine **MUST** maintain the original location and readability of all labels on this machine. If any label is removed or becomes unreadable, **REPLACE** that label before allowing the machine to enter service again. Contact Woodstock International, Inc. at (360) 734-3482 or www.shopfoxtools.com to order new labels.

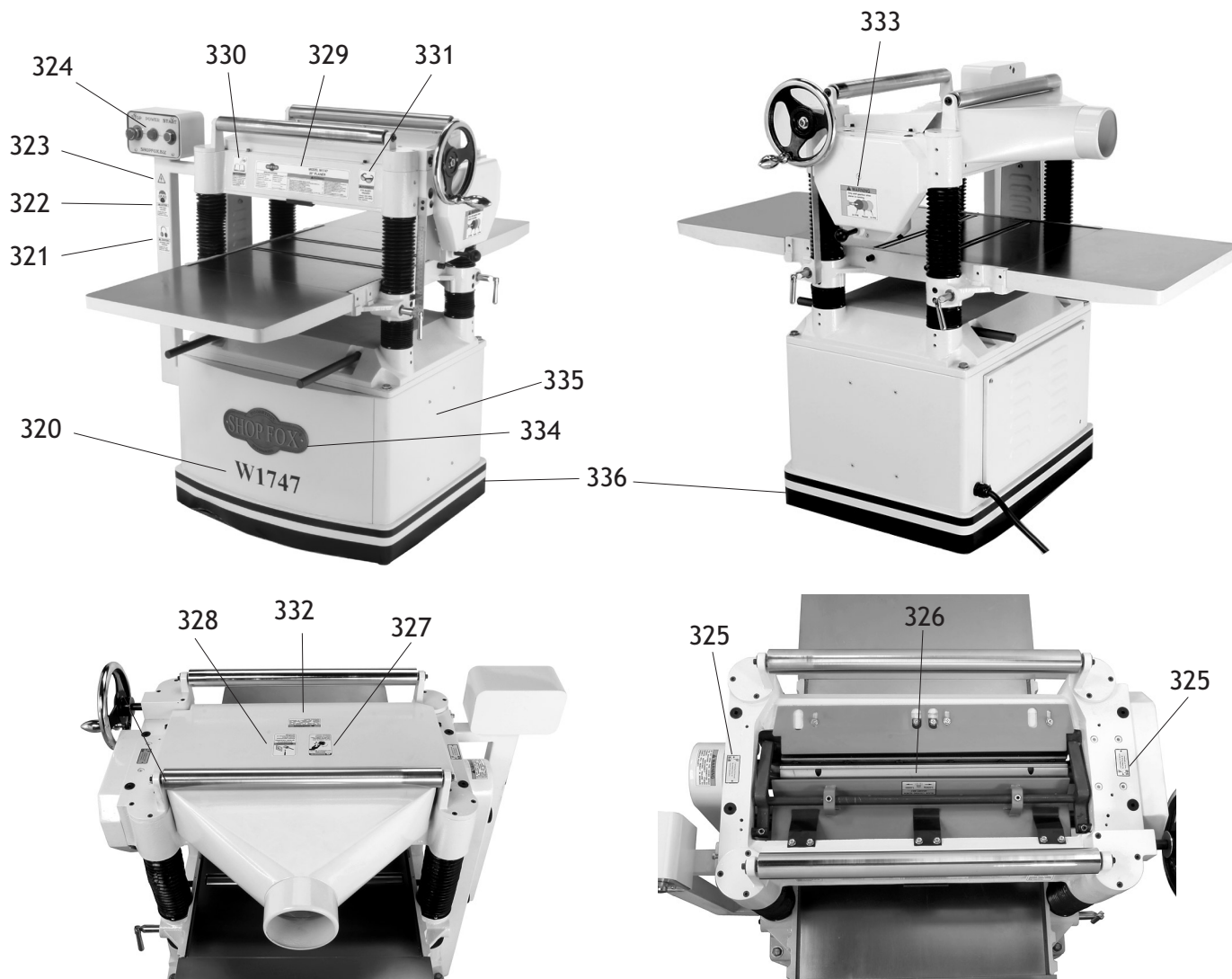

REF	PART #	DESCRIPTION
320	X1747320	MODEL NUMBER LABEL
321	XLABEL-15	EAR PROTECTION LABEL
322	X1747322	RESPIRATOR LABEL
323	XLABEL-04	ELECTRICITY LABEL
324	X1747324	CONTROL PANEL LABEL
325	X1747325	LUBRICATION LABEL
326	X1747326	ADJUST SCREW LABEL
327	X1747327	CUTTERHEAD WARNING LABEL
328	X1747328	UNPLUG POWER 220V LABEL

REF	PART #	DESCRIPTION
329	X1747329	MACHINE ID LABEL
330	XLABEL-08	READ MANUAL LABEL
331	XLABEL-01	SAFETY GLASSES LABEL
332	X1747332	SHUT COVER WARNING LABEL
333	X1747333	SPEED CHANGE LABEL
334	X1747334	SHOP FOX LOGO PLATE
335	XPAINTSF701	PAINT FOR SHOP FOX MACHINES
336	X1747336	DECORATIVE STRIPE TAPE

Warranty

Woodstock International, Inc. warrants all **SHOP FOX**[®] machinery to be free of defects from workmanship and materials for a period of two years from the date of original purchase by the original owner. This warranty does not apply to defects due directly or indirectly to misuse, abuse, negligence or accidents, lack of maintenance, or reimbursement of third party expenses incurred.

Woodstock International, Inc. will repair or replace, at its expense and at its option, the **SHOP FOX**[®] machine or machine part which in normal use has proven to be defective, provided that the original owner returns the product prepaid to the **SHOP FOX**[®] factory service center or authorized repair facility designated by our Bellingham, WA office, with proof of their purchase of the product within two years, and provides Woodstock International, Inc. reasonable opportunity to verify the alleged defect through inspection. If it is determined there is no defect, or that the defect resulted from causes not within the scope of Woodstock International Inc.'s warranty, then the original owner must bear the cost of storing and returning the product.

This is Woodstock International, Inc.'s sole written warranty and any and all warranties that may be implied by law, including any merchantability or fitness, for any particular purpose, are hereby limited to the duration of this written warranty. We do not warrant that **SHOP FOX**[®] machinery complies with the provisions of any law or acts. In no event shall Woodstock International, Inc.'s liability under this warranty exceed the purchase price paid for the product, and any legal actions brought against Woodstock International, Inc. shall be tried in the State of Washington, County of Whatcom. We shall in no event be liable for death, injuries to persons or property or for incidental, contingent, special or consequential damages arising from the use of our products.

Every effort has been made to ensure that all **SHOP FOX**[®] machinery meets high quality and durability standards. We reserve the right to change specifications at any time because of our commitment to continuously improve the quality of our products.



Warranty Registration

Name _____
 Street _____
 City _____ State _____ Zip _____
 Phone # _____ Email _____ Invoice # _____
 Model # _____ Serial # _____ Dealer Name _____ Purchase Date _____

The following information is given on a voluntary basis. It will be used for marketing purposes to help us develop better products and services. **Of course, all information is strictly confidential.**

1. How did you learn about us?

<input type="checkbox"/> Advertisement	<input type="checkbox"/> Friend	<input type="checkbox"/> Local Store
<input type="checkbox"/> Mail Order Catalog	<input type="checkbox"/> Website	<input type="checkbox"/> Other:

2. How long have you been a woodworker/metalworker?

<input type="checkbox"/> 0-2 Years	<input type="checkbox"/> 2-8 Years	<input type="checkbox"/> 8-20 Years	<input type="checkbox"/> 20+ Years
------------------------------------	------------------------------------	-------------------------------------	------------------------------------

3. How many of your machines or tools are Shop Fox®?

<input type="checkbox"/> 0-2	<input type="checkbox"/> 3-5	<input type="checkbox"/> 6-9	<input type="checkbox"/> 10+
------------------------------	------------------------------	------------------------------	------------------------------

4. Do you think your machine represents a good value? Yes No

5. Would you recommend Shop Fox® products to a friend? Yes No

6. What is your age group?

<input type="checkbox"/> 20-29	<input type="checkbox"/> 30-39	<input type="checkbox"/> 40-49
<input type="checkbox"/> 50-59	<input type="checkbox"/> 60-69	<input type="checkbox"/> 70+

7. What is your annual household income?

<input type="checkbox"/> \$20,000-\$29,000	<input type="checkbox"/> \$30,000-\$39,000	<input type="checkbox"/> \$40,000-\$49,000
<input type="checkbox"/> \$50,000-\$59,000	<input type="checkbox"/> \$60,000-\$69,000	<input type="checkbox"/> \$70,000+

8. Which of the following magazines do you subscribe to?

<input type="checkbox"/> Cabinet Maker	<input type="checkbox"/> Popular Mechanics	<input type="checkbox"/> Today's Homeowner
<input type="checkbox"/> Family Handyman	<input type="checkbox"/> Popular Science	<input type="checkbox"/> Wood
<input type="checkbox"/> Hand Loader	<input type="checkbox"/> Popular Woodworking	<input type="checkbox"/> Wooden Boat
<input type="checkbox"/> Handy	<input type="checkbox"/> Practical Homeowner	<input type="checkbox"/> Woodshop News
<input type="checkbox"/> Home Shop Machinist	<input type="checkbox"/> Precision Shooter	<input type="checkbox"/> Woodsmith
<input type="checkbox"/> Journal of Light Cont.	<input type="checkbox"/> Projects in Metal	<input type="checkbox"/> Woodwork
<input type="checkbox"/> Live Steam	<input type="checkbox"/> RC Modeler	<input type="checkbox"/> Woodworker West
<input type="checkbox"/> Model Airplane News	<input type="checkbox"/> Rifle	<input type="checkbox"/> Woodworker's Journal
<input type="checkbox"/> Modeltec	<input type="checkbox"/> Shop Notes	<input type="checkbox"/> Other:
<input type="checkbox"/> Old House Journal	<input type="checkbox"/> Shotgun News	

9. Comments: _____

CUT ALONG DOTTED LINE

FOLD ALONG DOTTED LINE

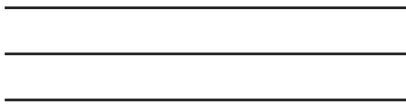

Place
Stamp
Here



WOODSTOCK INTERNATIONAL INC.
P.O. BOX 2309
BELLINGHAM, WA 98227-2309



FOLD ALONG DOTTED LINE

TAPE ALONG EDGES--PLEASE DO NOT STAPLE

Free Manuals Download Website

<http://myh66.com>

<http://usermanuals.us>

<http://www.somanuals.com>

<http://www.4manuals.cc>

<http://www.manual-lib.com>

<http://www.404manual.com>

<http://www.luxmanual.com>

<http://aubethermostatmanual.com>

Golf course search by state

<http://golfingnear.com>

Email search by domain

<http://emailbydomain.com>

Auto manuals search

<http://auto.somanuals.com>

TV manuals search

<http://tv.somanuals.com>